

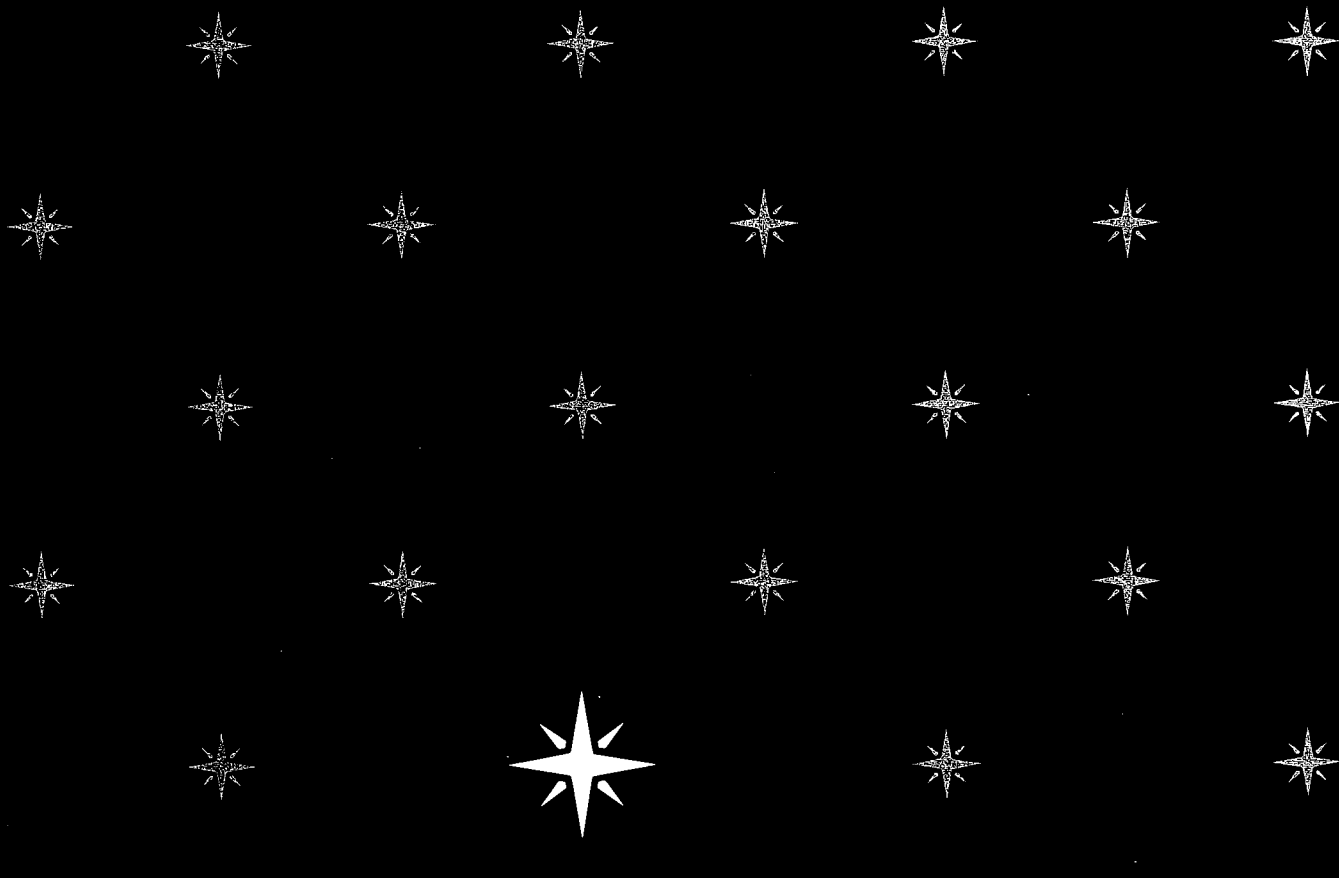

SERVICE
MANUAL **SR8100DC**

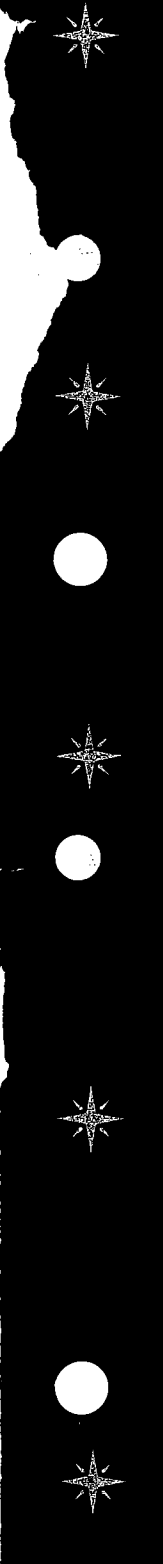

marantz[®]

model SR 8100DC

Stereophonic Receiver



INTRODUCTION

This service manual was prepared for use by Authorized Warranty Stations and contains service information for Marantz Model SR-8100DC Stereophonic Receiver.

Servicing information and voltage data included in this manual are intended for use by the knowledgeable and experienced technician only. All instructions should be read carefully. No attempt should be made to proceed without a good understanding of the operation of the receiver.

The parts list furnishes information by which replacement parts may be ordered from the Marantz Company. A simple description is included for parts which can usually be obtained through local suppliers.

1. P.W. BOARDS

1. Tuner/Phono	P100
2. Controller	P500
3. VFL and Signal LED	P501
4. PLL and L.P.F.	P502
5. Controller and F.I.P. Jumper	P503
6. Controller and PLL Jumper	P504
7. Main Amp	P700
8. Main Amp	P701
9. Power Supply	P800
10. Scan Step SW.	PC50
11. Tone Amp	PE00
12. Tone Volume	PE01
13. Connection	PE02
14. Vol/Balance	PG00
15. Tape Monitor SW.	PJ01
16. Protector	PL00
17. AC Power Relay	PQ00
18. Filter/Loudness	PS00
19. Speaker Terminal	PS01
20. Timer Switch	PS50
21. Key Board	PT00
22. Power Off Switch	PT50
23. Function SW.	PU00
24. C/F Display	PU50
25. Head Phone	PW01

2. TEST EQUIPMENT REQUIRED FOR SERVICING

This table lists the test equipment required for servicing the Model SR-8100DC Receiver.

Item	Manufacturer and Model No.	Use
AM Signal Generator		Signal source for AM alignment
Test Loop		Use with AM Signal Generator
FM Signal Generator MPX Signal Generator	Sound Technology Model 1000A	Signal source for FM alignment Stereo separation alignment and trouble shooting
Distortion Analyzer Audio Oscillator AC VTVM	Sound Technology Model 1700A	Distortion measurements Sinewave and squarewave signal source Voltage measurements (AC)
Oscilloscope	Tektronix Model T932 Philips Model 3232	Waveform analysis and trouble shooting and ASO alignment
Frequency Counter	Fluke Model 1900A	MPX Oscillator adjustment (VCO)
Circuit Tester		Trouble shooting
DC VTVM	Fluke Model 8000 "Digital" Simpson Model 313, Triplet Model 801	Voltage measurements (DC)
AC Wattmeter	Simpson Model 1379	Monitors primary power to amplifier
AC Ammeter	Commercial Grade (1-10A)	Monitors amplifier output under short circuit condition
Line Voltmeter	Simpson Model 1359	Monitors potential of primary power to amplifier
Variable Autotransformer	Superior Electronic Co., Powerstat Model 116B-10A	Adjusts level of primary power to amplifier
Shorting Plug	Use phono plug with 600-ohm across center pin and shell	Shorts amplifier input to eliminate noise pickup
Output Load (8 ohms, ±0.5%, 100W)	Commercial Grade	Provides 8-ohm load for amplifier output termination
Output Load (4 ohms, ±0.5%, 100W)	Commercial Grade	Provides 4-ohm load for amplifier output termination

TABLE OF CONTENTS

Section	Page
1. P.W. BOARDS	1
2. TEST EQUIPMENT REQUIRED FOR SERVICING	1
3. FREQUENCY SYNTHESIZER RADIO TUNING SYSTEM	2
4. ALIGNMENT PROCEDURES	11
5. VOLTAGE CONVERSION	14
6. BLOCK DIAGRAM	15
7. DIAGRAM AND COMPONENT LOCATIONS	16
7.1 Tuner/Phono Amp. (P100) Schematic Diagram and Component Locations	16
7.2 Filter/Loudness (PS00) Schematic Diagram and Component Locations	16
7.3 Head Phone (PW01) Schematic Diagram and Component Locations	18
7.4 Timer Switch (PS50) Schematic Diagram and Component Locations	18
7.5 Tape Monitor Switch (PJ00) Schematic Diagram and Component Locations	18
7.6 Controller (P500) Schematic Diagram and Component Locations	19
7.7 PLL/L.P.F. (P501) Schematic Diagram and Component Locations	19
7.8 VFL/Signal LED (P502) Schematic Diagram and Component Locations	19
7.9 EQ Out (PK00) Schematic Diagram and Component Locations	21
7.10 C/F Display (PU50) Schematic Diagram and Component Locations	21
7.11 Vol/Valance (PG00) Schematic Diagram and Component Locations	21
7.12 Function Switch (PU00) Schematic Diagram and Component Locations	21
7.13 Main Amp. (P701) Schematic Diagram and Component Locations	22
7.14 Main Amp. (P700) Schematic Diagram and Component Locations	22
7.15 Key Board Switch (PT00) Schematic Diagram and Component Locations	22
7.16 Power Off Switch (PT50) Schematic Diagram and Component Locations	23
7.17 Scan Step Switch (PC50) Schematic Diagram and Component Locations	23
7.18 Speaker Protector (PL00) Schematic Diagram and Component Locations	23
7.19 Tone Amp. (PE00) Schematic Diagram and Component Locations	24
7.20 Speaker Switch (PS01) Schematic Diagram and Component Locations	24
7.21 Connection (PE01) Schematic Diagram and Component Locations	24
7.22 Tone Amp. (PE02) Schematic Diagram and Component Locations	24
7.23 AC Power Relay (PQ00) Schematic Diagram and Component Locations	25
7.24 Power Supply (P800) Schematic Diagram and Component Locations	25
7.25 Tone Volume (PE03) Schematic Diagram and Component Locations	26
7.26 Controller/Fip (P503) Schematic Diagram and Component Locations	26
7.27 Controller/PLL (P504) Schematic Diagram and Component Locations	26
8. EXPLODED VIEW AND PARTS LIST	27
9. TECHNICAL SPECIFICATIONS	45
10. SCHEMATIC DIAGRAM	46

MODEL SR8100DC STEREOHONIC RECEIVER

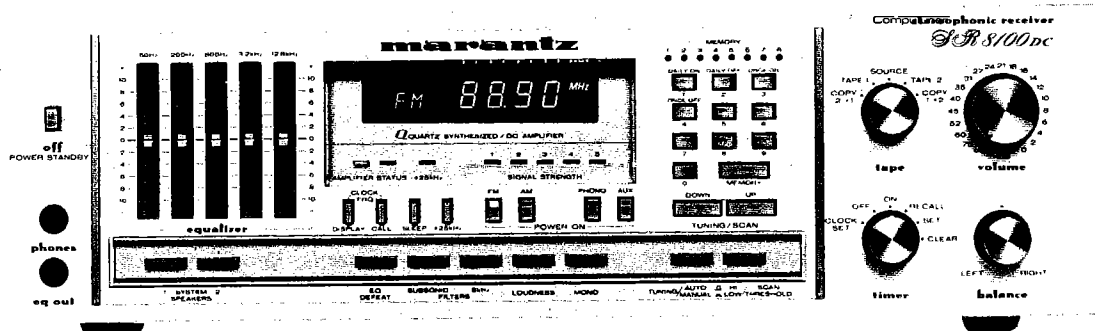

MARANTZ DESIGN AND SERVICE

Using superior design and selected high grade components, MARANTZ Company has created the ultimate in stereo sound. Only original MARANTZ parts can insure that your MARANTZ product will continue to perform to the specifications for which it is famous.

Parts for your MARANTZ stereo are generally available within 72 hours throughout the nation via a toll-free line to our National Parts Depot in California. The sales professionals who take your call immediately refer to their own desk top computer terminal and can quickly determine the availability and price information you require. If, for some reason, your order should exceed our available stock, we usually can instantly provide an alternate replacement part or current delivery information. When the order is placed and confirmed, the computer simultaneously generates "hard copy" orders at the distribution center. As hard copies come directly from the computer to the national parts depot, your requested stock is assembled and prepared for shipment and placed on the first available carrier for delivery to you.

ORDERING PARTS

Phone orders will eliminate mail delays, and we encourage the use of this method. If you order by mail, use MARANTZ parts order forms which are available from our National Parts Depot located at the following address:

SUPERSCOPE NATIONAL PARTS DEPARTMENT
20525 Nordhoff Street
Chatsworth, California 91311
Phone: 1-800-423-5108
1-213-998-9333

The following information must be supplied to eliminate delays in processing your order:

1. Complete address.
2. Complete part numbers.
3. Complete description of parts.
4. Model number for which part is required (indicate MARANTZ).
5. Account number (for account customers only).

Direct consumers will be provided with the current retail price quotation on available parts in order to advise them of the cost of the parts and shipping.

OVERSEAS PARTS ORDERING

Parts may also be ordered from the following overseas addresses:

U.S.A.	CANADA	AUSTRALIA	JAPAN
Marantz Company, Inc. National Service Dept. P.O. Box 577 Chatsworth, CA 91311 U.S.A.	Superscope Canada, Ltd. 3710 Nashua Drive Mississauga Ontario, Canada L4V1M5	Marantz Australia 32 Cross Street Brookvale, NSW 2100 Australia	Marantz Japan, Inc. 3622 Kamitsuruma Sagamihara-shi Kanagawa, Japan
EUROPE			
MARANTZ AUSTRALIA PTY., LTD. 32 Cross Street Brookvale, N.S.W. 2100 Australia	MARANTZ GERMANY GMBH Max-Planckstrasse 22 6072 Dreieich 1 West Germany	MARANTZ AUDIO U.K., LTD. Unit 15/16, Saxon Way Moor Lane, Harmondsworth UB 7 O.L.W. Great Britain	MARANTZ SVENSKA A.B. Franzengatan 6 10425 Stockholm Sweden
MARANTZ EUROPE S.A. 326 Avenue Louise Bte 32 1050 Brussels Belgium	MARANTZ BELGIUM 45 Rue Auguste Van Zande 1080 Brussels Belgium	MARANTZ FRANCE 4 Rue Bernard Palissy 92600 Asnieres France	MARANTZ NORSKE A.S. Refstadalleen 13 Oslo 5 Norway

All of the above locations are fully equipped to take care of your total service needs. Because various countries have differing configuration requirements, it is necessary that you contact the service facility in your particular country. In the event that there is no service location listed for your country, please contact the nearest facility for the necessary assistance.

3. FREQUENCY SYNTHESIZER RADIO TUNING SYSTEM

3.1 Construction of Synthesizer System

This frequency synthesizer is composed of a micro-computer (MN1455LF), PLL LSI (MN6147), lowpass filter, crystals and fluorescent indicating tubes, as shown in Fig. 1.

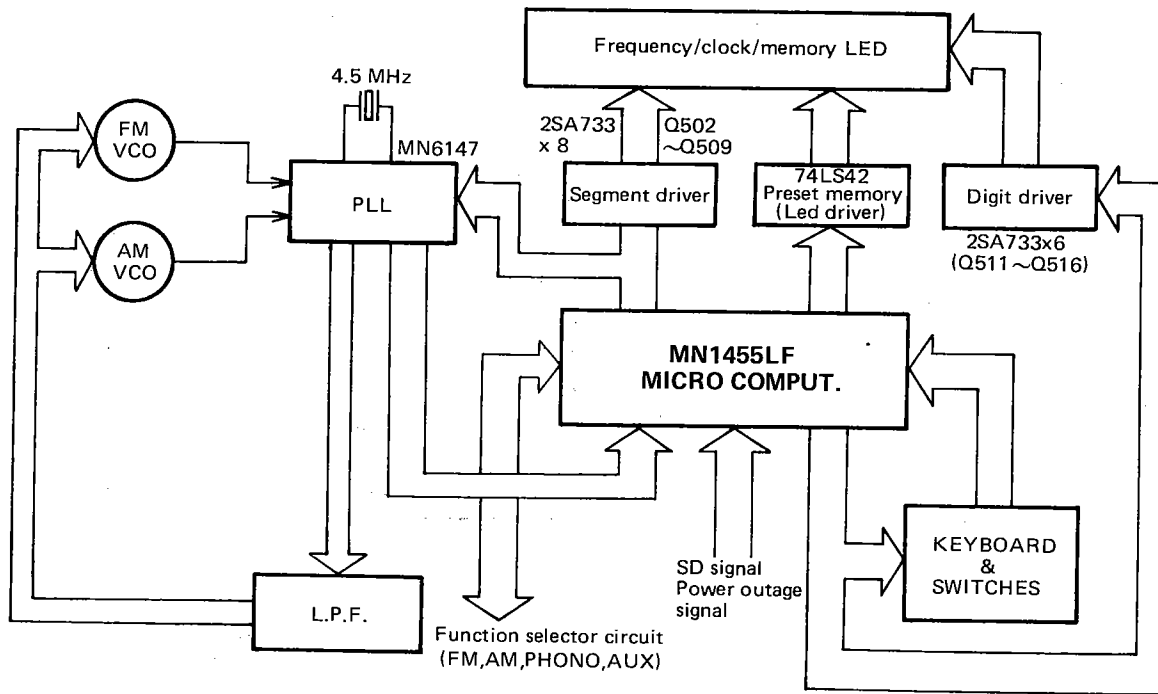

Figure 1. Block Diagram of Synthesizer

3.2 Microcomputer MN1455LF

(1) Terminal connections

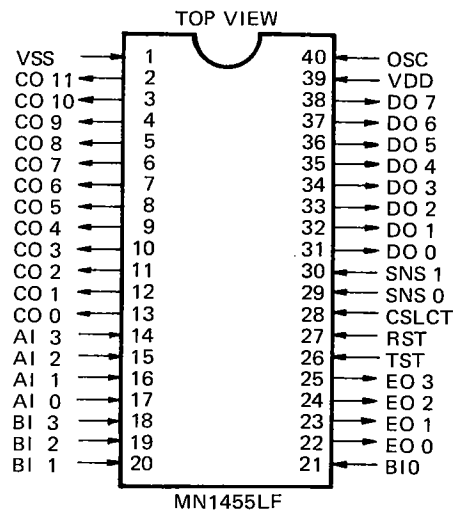

Figure 2.

(2) Specifications

Item	Symbol	Ratings	Unit	
Power supply voltage	V_{DD}	$-0.3 \sim +10$	V	
Input terminal voltage	V_I	$-0.3 \sim V_{DD} + 0.3$	V	
Output terminal voltage	V_O	$-0.3 \sim V_{DD} + 0.3$	V	
Clock input terminal voltage	V_{OSC}	$-0.3 \sim V_{DD} + 0.3$	V	
Peak envelope output current	I_{OH} (peak)	C port	-0.5	mA
		D port		
		E port		
	I_{OL} (peak)	C port	8	mA
		D port		
		E port		
Average output current	I_{OH}^{**} (avg.)	C port	-0.25	mA
		D port		
		E port		
	I_{OL}^{**} (avg.)	C port	4	mA
		D port		
		E port		
Power consumption	P_T^*	500	mW	
Ambient temperature	T opr	$-20 \sim +70$	$^{\circ}\text{C}$	
Storage temperature	T stg	$-55 \sim +100$	$^{\circ}\text{C}$	

(3) Functions of terminals

Pin Code	Pin Symbol	Function	Pin Code	Pin Symbol	Function	
1	VSS	Ground terminal	22	E00	Data output terminal for BCD driver	
2	CO11	LW source control output terminal, H level output	23	E01	SN74LS42 Preset memory display	
3	CO10	MW source control output terminal, H level output	24	E02	LED (M1 – M8) and PHONO, AUX1	
4	CO9	FM source control output terminal, H level output	25	E03	and AUX 2 source LED control terminal	
5	CO8	AC outlet output terminal, H level output	26	TST	Test terminal. Connected to ground	
6	CO7	Muting output terminal, H level output	27	\overline{RST}	Reset terminal. When power is supplied to the micro computer, the level is L. In the normal condition, the level is H.	
7	CO6	Data latch clock output terminal for MN6147	28	\overline{CSLCT}	To use the SNS1 for counter mode, connect to ground. (For the models without clock, connect to ground.)	
8	CO5	Frequency display digit output and switch and key matrix scan port. The scan is low level. CO5 ... G1, CO4 ... G2, CO3 ... G3, CO2 ... G4, CO1 ... G5, CO0 ... GS1, GS2	29	SNS0	Lock detection input terminal for PLL system. The MN6147 ALDO signal is applied to this terminal via the filter. This terminal is used for auto up/down station seek. Lock mode – H level input Unlock mode – L level input	
9	CO4		Switch and key matrix input terminal. The input signal is always supplied from the micro computer standard routine.	30	SNS1	Reference clock (250 Hz) input terminal. Input from MN6147 CK2. For the models without clock, connect to ground.
10	CO3			31	DO0	MN6147 data output and display segment output terminal. The segment scan is low.
11	CO2			32	DO1	
12	CO1			33	DO2	
13	CO0			34	DO3	
14	Ai3	35		DO4		
15	Ai2	36	DO5			
16	Ai1	37	DO6	Power supply terminal (+5V ± 10%)		
17	Ai0	38	DO7			
18	Bi3	Station detector signal (tuning detector signal) input terminal. Checks the input only in the auto up/down station seek. Station detector signal – H level input Non station detector signal – L level input. In the normal condition, the muting is released regardless of the station detector signal.	39	VDD	Micro computer clock (526.5 kHz) input terminal. Input from MN6147 CK1.	
19	Bi2	Power outage (battery back-up) detection terminal. In the battery back-up mode, the output of the micro computer becomes low and only the clock is counted. When the power is recovered, the unit is set to OFF mode (OFF key on condition) and display indicates the current time. Battery back-up mode – L level input Normal power supply – H level input	40	OSC		

3.3 PLL LSI MN6147

(1) Terminal connections

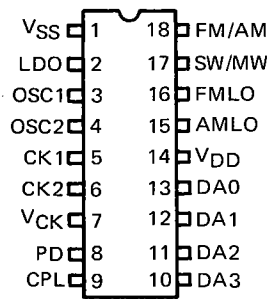

Figure 3.

(2) Specifications

Absolute maximum ratings (Ta = 25°C)

Item	Symbol	Condition	Ratings	Unit
Power supply voltage	V _{DD}		-0.3 ~ +10	V
Input voltage	V _I	V _{SS} = 0V	-0.3 ~ V _{DD} +0.3	V
Output voltage	V _O		-0.3 ~ V _{DD} +0.3	V
Allowable loss	P _D		250	mW
Operating temperature	T _{opr}		-30 ~ +70	°C
Storage temperature	T _{stg}		-55 ~ +100	°C

(3) Block diagram

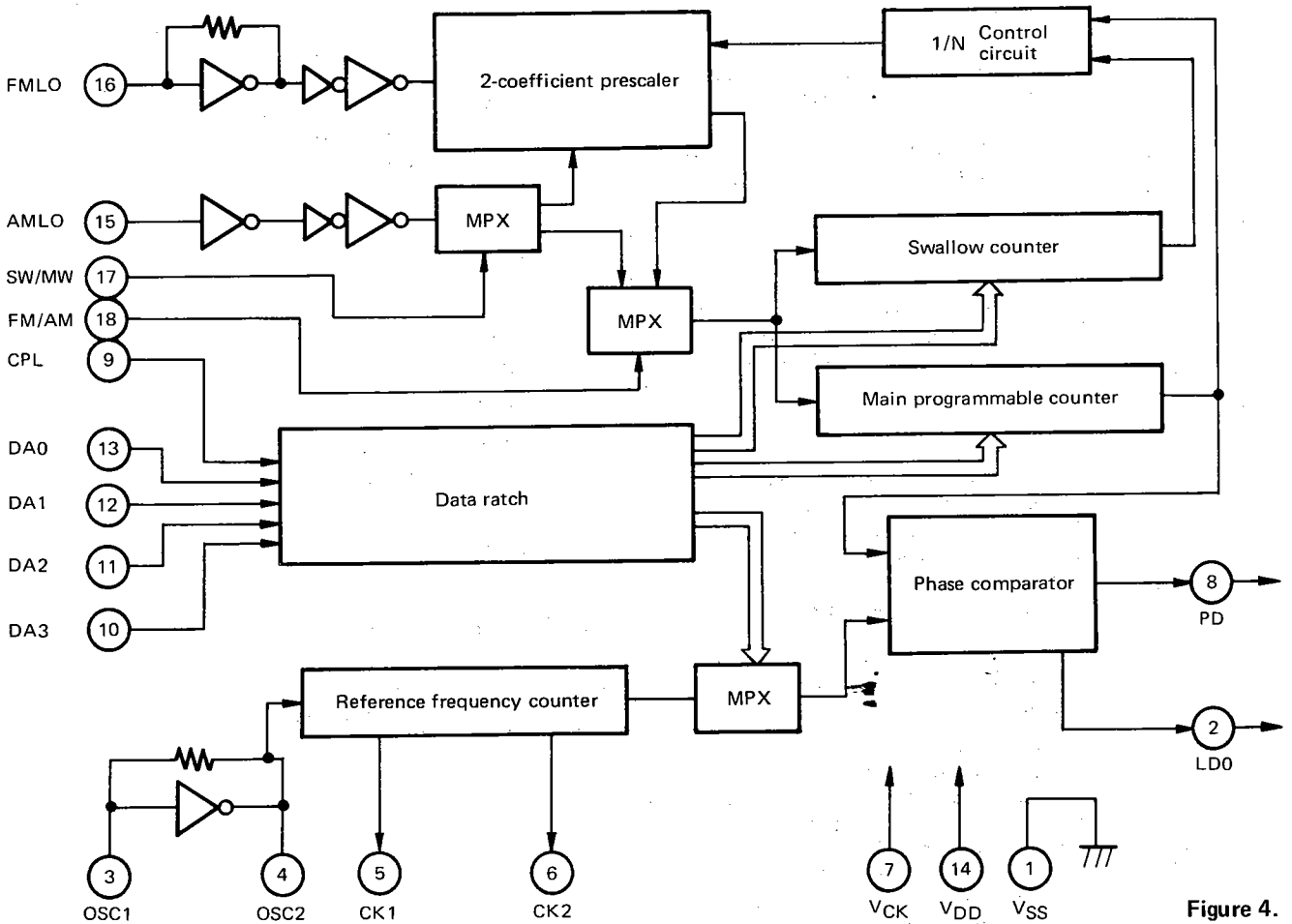

Figure 4.

(4) Functions of terminals

No.	Symbol	Description	No.	Symbol	Description
1	VSS	Ground	8	CPL	Latch clock
2	LDO	Oscillator output	9	DA3~DA0	Data address input
3	OSC1 ~ 2	Crystal oscillator (4.5 MHz)	10	VDD	Main power supply
4	CK1	Clock output (562.5 kHz)	11	AMLO	AM local oscillator input
5	CK2	Clock output (250 Hz)	12	FMLO	FM local oscillator
6	VCK	Clock circuit back-up	13	SW/MW	SW/MW selector
7	PD	Phase comparator output	14	FM/AM	FM/AM selector

(5) Data input timing chart

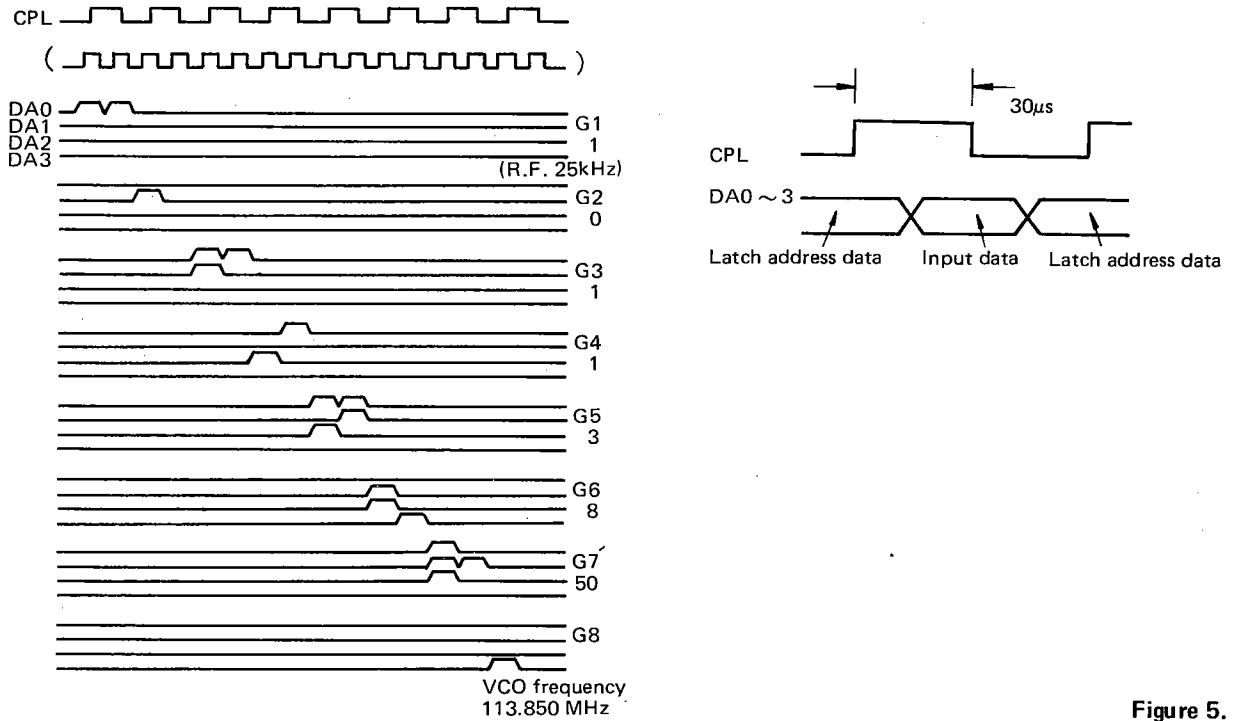

Figure 5.

(6) Relationship between data input terminal and programmable counter

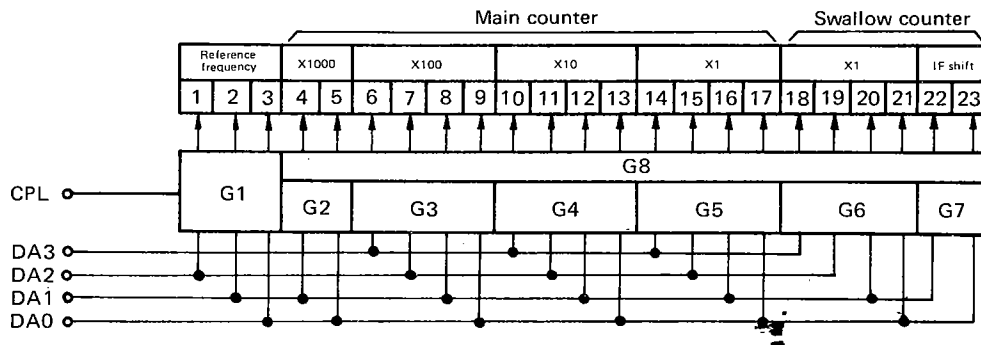

Figure 6.

(7) Latch group code list

Latch Input code	G1	G2	G3	G4	G5	G6	G7	G8
DA3	L	L	L	L	L	L	L	H
DA2	L	L	L	H	H	H	H	x
DA1	L	H	H	L	L	H	H	x
DA0	H	L	H	L	H	L	H	x

(9) IF shift list

kHz Input code	0	25	50	75
DA1	L	L	H	H
DA0	L	H	L	H

(8) Reference frequency (r_1) code list

kHz Input code	2.5	25	9	10	5	1
DA2	L	L	L	L	H	H
DA1	L	L	H	H	L	H
DA0	L	H	L	H	x	x

(10) FM, SW, MW (LW) signal process list

Input signal		Terminal code	
Signal name	Terminal	FM/AM(18)	SW/MW(17)
FM	(16)	H	X
SW	(15)	L	H
MW (LW)	(15)	*L	L

3.4 PLL Synthesizer Tuning System: Theory of Operation

As shown in the Figure, the output frequency of the FM/AM local oscillator is automatically locked to a constant frequency by the PLL network which is operating under microprocessor control.

In the FM mode, part of the local oscillator output is coupled to the FM input terminal of the PLL block via a buffer amplifier (for example, when the received frequency is 98.1 MHz, the local oscillation frequency is $98.1 + 10.7 = 108.8$ MHz).

Meanwhile, the microprocessor accepts frequency data input from the keyboard and provides the data of, say, 98.1 MHz to the display. It also provides frequency dividing-ratio data to the PLL block. Since the reference frequency for the FM mode is 25 kHz, dividing ratio N is determined as follows:

$$N = 108.8 \text{ MHz} \div 0.025 = 4352$$

When the 50 kHz stepping interval is selected in the FM mode, the FM frequency band is between 87.5 and 108.0

MHz, and hence the local frequency band is between 98.2 and 118.7 MHz. As a result, the dividing ratio is between 3928 and 4748.

Once dividing ratio is determined, the local oscillation frequency is divided by N, and the resultant signal phase is compared with the reference signal phase. The reference signal is created by dividing the master oscillator output of 4.5 MHz, and its frequency accuracy depends on that of the quartz crystal element used in the master oscillator.

The frequency divided in the PLL block ($108.8 \text{ MHz} \div 435 = 25 \text{ kHz}$) is phase-compared with the reference frequency of 25 kHz, and the phase difference between the two signals is converted by the PLL into a corresponding pulse array. This pulse array is coupled to a low-pass filter, where it is converted into a corresponding DC level, which is then feed back to the local oscillator's control input to control the local oscillator output frequency to a constant.

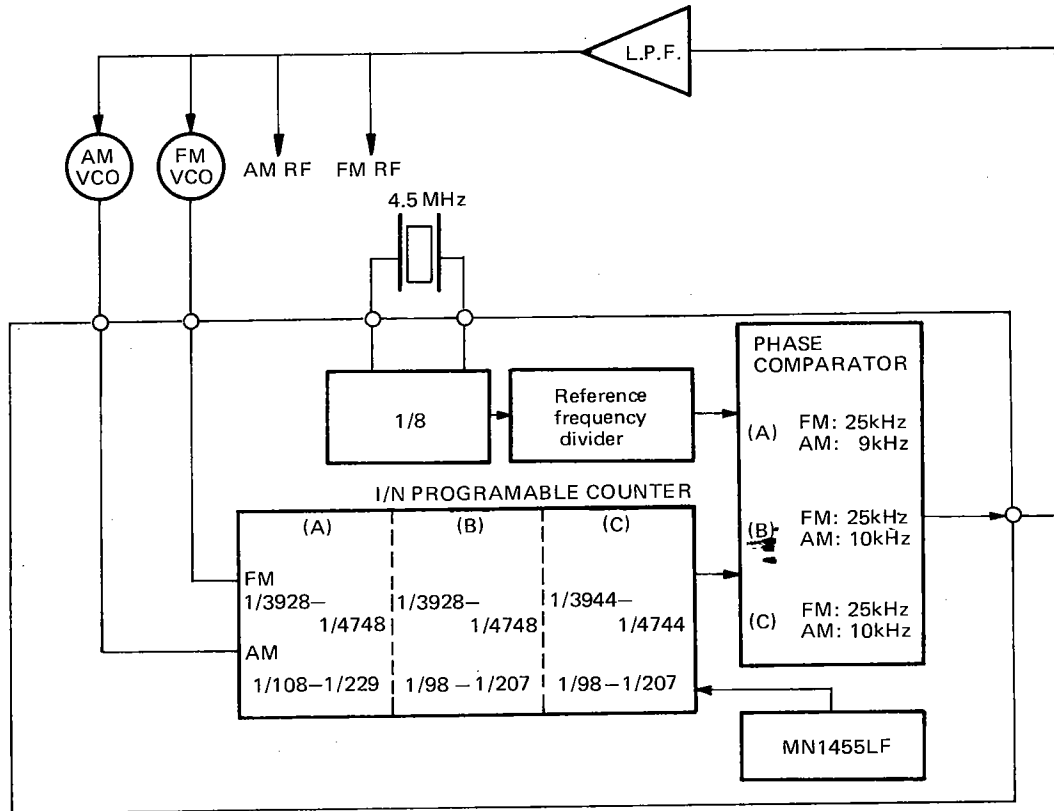

Figure 7.

	Scan Step	Receiving frequency	Local oscillator frequency	Number of channels
(A)	FM 50 kHz	87.50 ~ 108.0 MHz	98.2 ~ 118.7 MHz	411
	AM 9 kHz	522 ~ 1611 kHz	972 ~ 2061 kHz	122
(B)	FM 50 kHz	87.50 ~ 108.0 MHz	98.2 ~ 118.7 MHz	411
	AM 10 kHz	530 ~ 1620 kHz	980 ~ 2070 kHz	109
(C)	FM 200 kHz	87.9 ~ 107.9 MHz	98.6 ~ 118.6 MHz	101
	AM 10 kHz	530 ~ 1620 kHz	980 ~ 2070 kHz	109

3.5 Description of Switches

Switch and Key Matrix

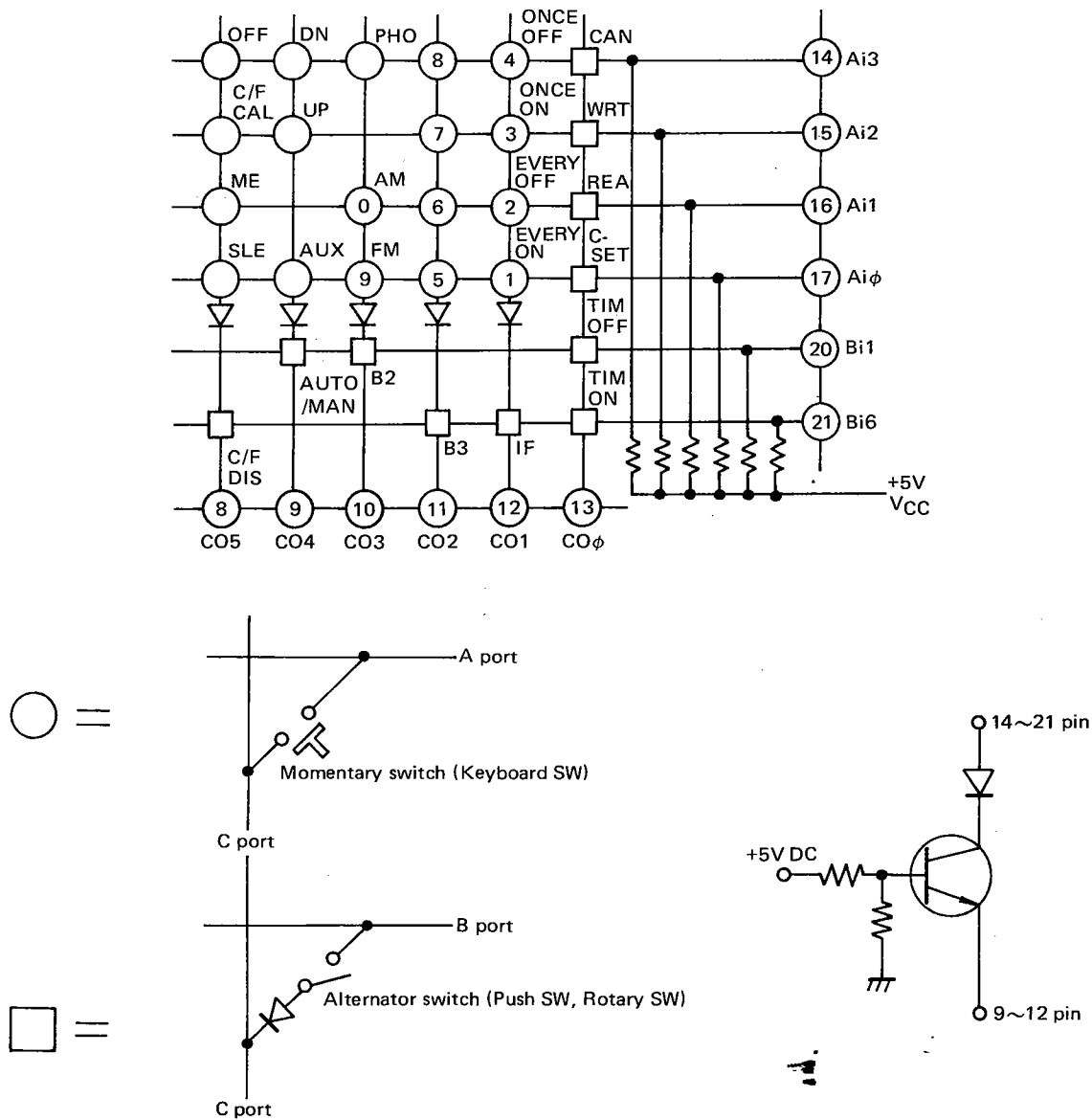

Figure 8.

Switches 0–9: these switches are used for read/write operations for memories CH.1-8, timer set-up, and read/write operations for EVERY ON/OFF and ONCE ON/OFF data.

UP/DN switches: when the Auto/Manual switch is set at Auto, pressing these switches scans frequencies up or down until a search signal is input.

When the switch is set at Manual, each depression of these switches steps up or down the frequency by one step. When the switches are held down continuously for more than 1 second, continuous frequency scanning starts.

FM/AM/PHONO/AUX: select input program sources. The FM and AM selector switches are shared by the 9 and 0 numerical keys.

C/F CALL: recalls time and frequency data for 5 seconds.
C/F DISPLAY: switches between time and frequency display.

SLE: used to set up the sleep timer function. This switch function is independent of the timer function.

AUTO/MANUAL: switches between the muting and scanning functions in the FM mode.

B2/B3: select scan stepping intervals with the following combinations:

AM (kHz)	FM (kHz)	B2	B3
9	50	OFF	OFF
10	50	OFF	ON
10	200	ON	ON

IF: controls the intermediate frequency in the FM mode over +25 kHz.

CANCEL: WRT, REA, C, SET, MANUAL.

TIMER: selects timer modes.

Indicator

The indicator employs fluorescent tubes for dynamic lighting.

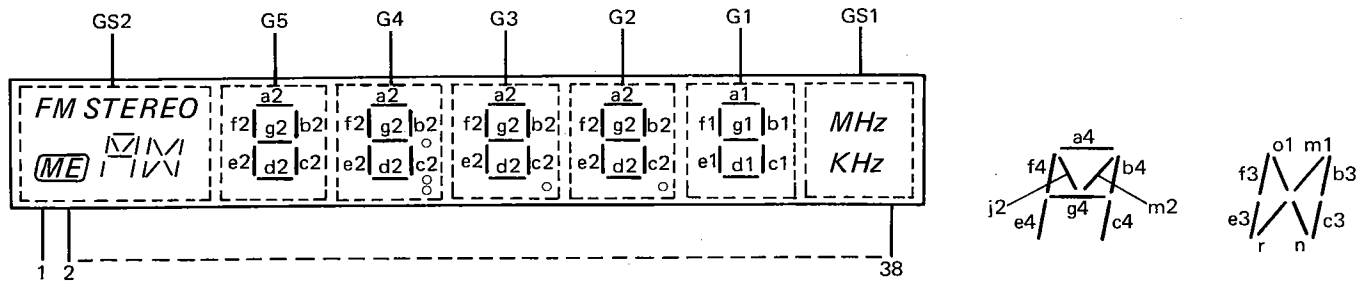

Figure 9.

Pin No.	Connection	Pin No.	Connection	Pin No.	Connection	Pin No.	Connection
1	F	11	b ₄	21	G ₃	31	a ₂
2	FM STEREO	12	a ₄	22	e ₂	32	g ₁
3	ME	13	G ₅	23	Dp ₃	33	b ₁ , e ₁
4	GS ₂	14	j ₁ , m ₁	24	Dp ₂	34	GS ₁
5	j ₂ , m ₂	15	n, r	25	d ₂	35	a ₁ , f ₁ , c ₁ , d ₁
6	g ₄	16	b ₃ , c ₃ , e ₃ , f ₃	26	G ₂	36	kHz
7	e ₄	17	G ₄	27	Dp ₁	37	MHz
8	d ₄	18	g ₂	28	C ₂	38	F
9	c ₄	19	f ₂	29	b ₂		
10	GS ₂	20	Col	30	G ₁		

Details of display

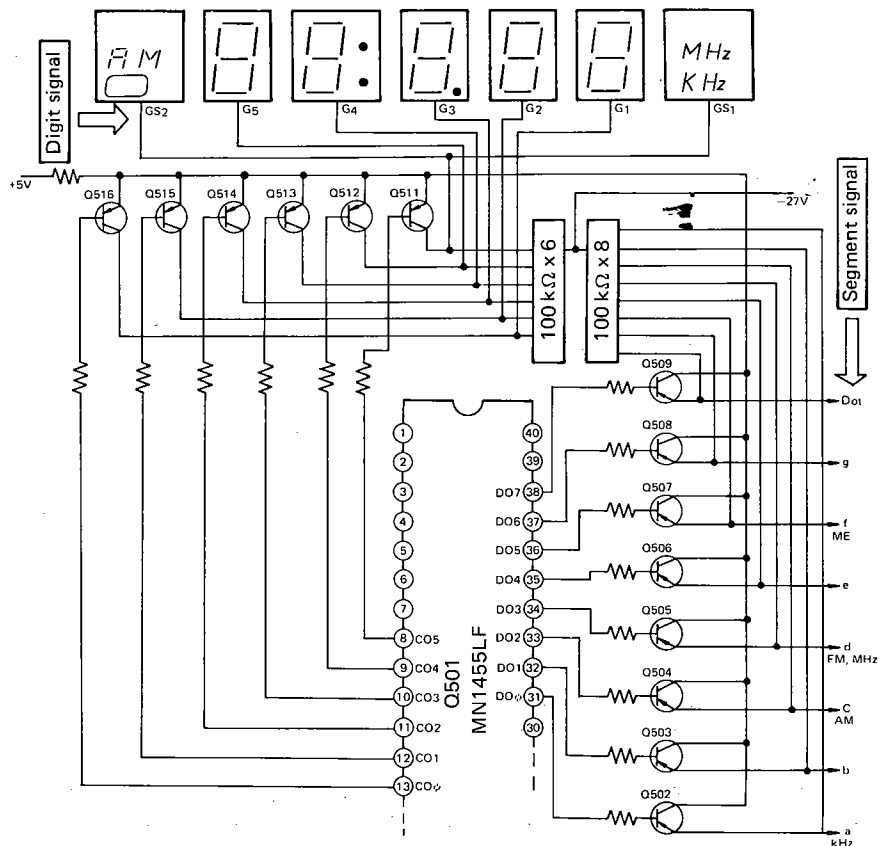

Figure 10.

Dynamic lighting timing chart

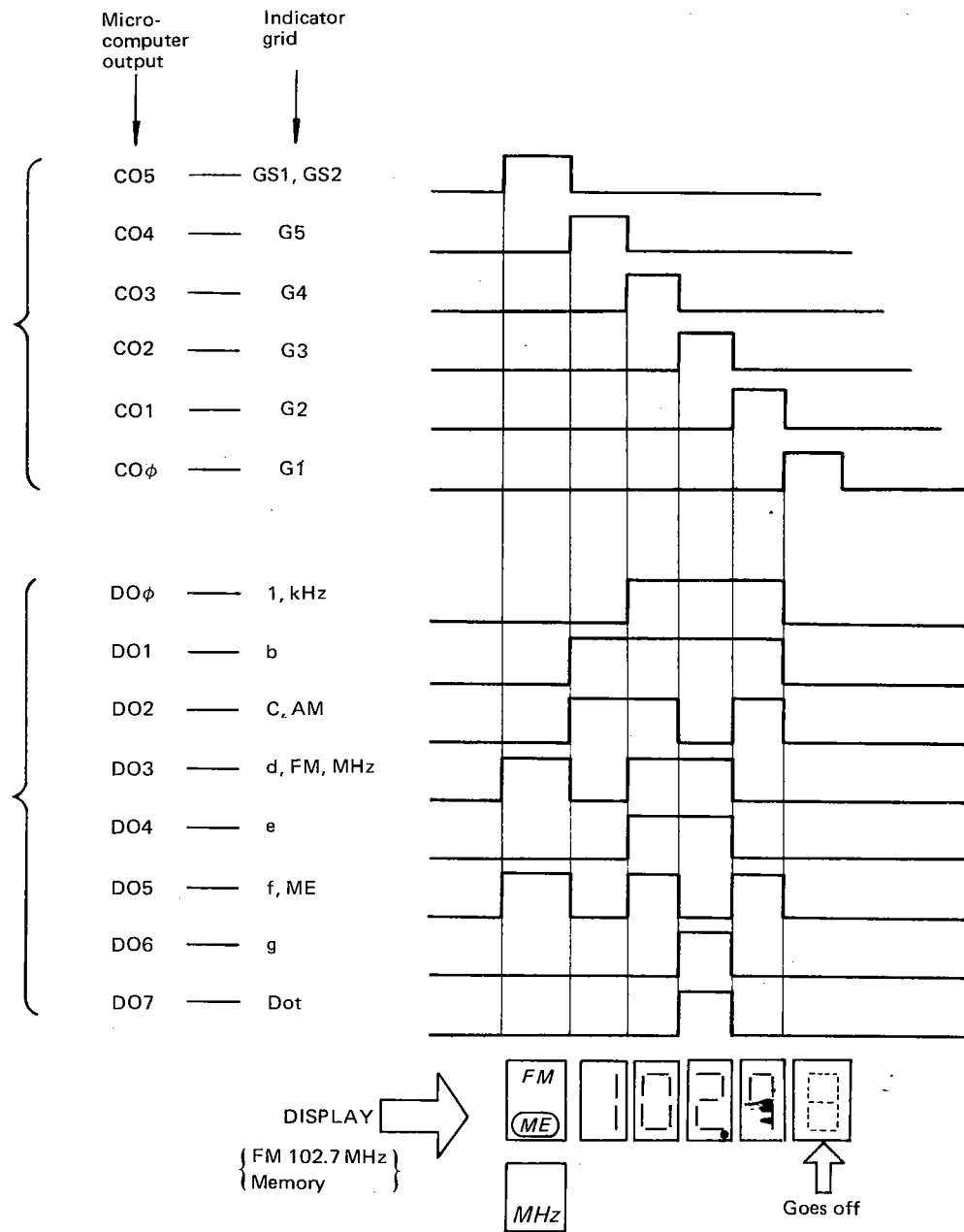

Figure 11.

4. ALIGNMENT PROCEDURES

AUDIO ALIGNMENT (FUNCTION switch in AUX position and VOLUME control in the minimum position at NO load)

4.1 DC of set (Adjust with a digital volt meter.)

Test point — SPK out (L & R)
 Adjusting point — R705 (L), R706 (R)
 Specified values — 0 mV

4.2 Idling current (Adjust with a digital volt meter.)

Test point — J705 ~ J706 (L), J707 ~ J708 (R)
 Adjusting point — R717 (L), R718 (R)
 Specified value — 13.2 mV (20 mA)

A dummy resistor of 47 kohms must be connected across the tuner output terminals before alignment.

4.3 FM Alignment Procedures (Selector switch in the "FM" position and mode/tuning switch in the "Mono/Manual" position)

FM Local Oscillator Alignment (Scan step selector switch (SC51) in the "50 kHz" position)

Step	Signal Source Connection	Signal Frequency	Indicator Connection	Set the Digital Read out Frequency to:	Adjust:
1			DC Volt meter in 30V and 3V range to point (A) (J116)	108.00 MHz	C142 for 20.0V
2				87.50 MHz	L104 for 3.0V
3	Repeat steps 1 and 2.				

FM RF Alignment

Step	Signal Source Connection	Signal Frequency	Indicator Connection	Set the Digital Read out Frequency to:	Adjust:
1	RF generator to FM antenna terminals (B) through matching network (300 ohms balanced) (Maintain RF level below limit)	106.10 MHz	VTVM to L or R channel output (JJ01 or JJ02)	106,10 MHz	C101, C105, C107 for maximum output and minimum distortion
2		90.10 MHz		90.10 MHz	L101, L102, L103 for maximum output and minimum distortion
3	Repeat steps 1 and 2.				
4	RF generator to FM antenna terminals (B) through matching network (300 ohms balanced) (Maintain RF level below limit)	98.10 MHz	VIVM to L or R channel output (JJ01 or JJ02)	98.10 MHz	L106 for maximum output and minimum distortion
5		98.10 MHz	"O" Center Meter or DC current meter in 100 μ A range to point (C) (J109 and J110)		L108 Core so that the meter indicator its center or may read "O"
6	RF generator 1 mV output to FM antenna terminals B through matching network (300 ohms, balanced)	98.10 MHz	Distortions meter to L or R Channel output (JJ01 or JJ02)	98.10 MHz	L108 core for minimum distortion
7	RF generator 300 μ V				R136 so that signal Strength Led may light 5 points

Circuit Alignment (FM Stopping Level of Scanning, FM Stereo Indicator threshold Level)

Signal Source Connection	Signal Frequency	Indicator Connection	Set the Digital Read out Frequency to:	Adjust:
RF generator 12.5 μ V output to FM antenna terminal (B) network (300 ohms balanced)	98.10 MHz	VTVM to R or L channel output (JJ01 or JJ02)	98.10 MHz	R131 for 12.5 μ V threshold Level (Setting to Auto position of mode switch & Low Level position of threshold Level switch)

ex Alignment Procedures (Function switch in the "FM" position, Auto/Manual switch in the Auto position)

Signal Source Connection	Signal Frequency	Indicator Connection	Set the Digital Read out Frequency to:	Adjust:
RF generator to FM antenna terminals (B) through matching network (300 ohms, balanced), with 1 mV FM stereo simulator RF level and Pilot 9% modulation	No. modulation & pilot off (J111)	Frequency counter to point (D) (J111)	98.10 MHz	R304 so that Frequency counter may precisely read 76 KHz R307 so that minimum output should be the same in both channels
	Pilot only	VTVM to right and left channel output (JJ01 or JJ02)		
RF generator to FM antenna terminals (B) through matching network (300 ohms balanced) with 1 mV FM stereo simulator RF level and 100% modulation (pilot 9%)	Stereo, left (1,000 Hz)	VTVM to right channel (JJ01 or JJ02)	98.10 MHz	R322 for minimum output and same separation in both channels
	Stereo right (1,000 Hz)	VTVM to left channel output terminal (JJ01 or JJ02)		

Repeat step 3 and 4.

AM ALIGNMENT PROCEDURES (Function Switch in the "AM" position)

Local Oscillator Alignment (Scan Step Selector switch (SC51) in the "10 KHz" position)

Signal Source Connection	Signal Frequency	Indicator Connection	Set the Digital Read out Frequency to:	Adjust:
-	-	DC Volt meter in 30V and 3V range to point (A) (J116)	1620 KHz	CA16 for 22V
			530 KHz	LA02 for 2.0V

Repeat step 1 and 2.

Alignment

Signal Source Connection	Signal Frequency	Indicator Connection	Set the Digital Read out Frequency to:	Adjust:
Signal generator to point (E) (JA07)	450 KHz marker	Oscilloscope to point (F) (JA03)	Quiet point on band	LA03 for maximum and symmetric response

AM RF Alignment

Step	Signal Source Connection	Signal Frequency	Indicator Connection	Set the Digital Read out Frequency to:	Adjust:
1	Apply the signal to the AM loop antenna from the RF generator, using the test loop. As per the Figure 12 (with 3 mV/m)	1400 KHz	VTVM to L or R Channel output (JJ01 or JJ02)	1400 KHz	CA02 for maximum output
2		600 KHz		600 KHz	LA01 for maximum output
3	Repeat step 1 and 2 as necessary to obtain maximum sensitivity.				
4		1000 KHz		1000 KHz	RA11 so that signal strength LED may light 5 point

PLL Oscillator Alignment (Function Switch in the "AM" position)

Step	Signal Source Connection	Signal Frequency	Indicator Connection	Set the Digital Read out Frequency to:	Adjust:
1	No signal	-	Frequency counter to point (G) (J117)	1400 KHz	CS15 so that frequency may precisely read 1850,000 KHz

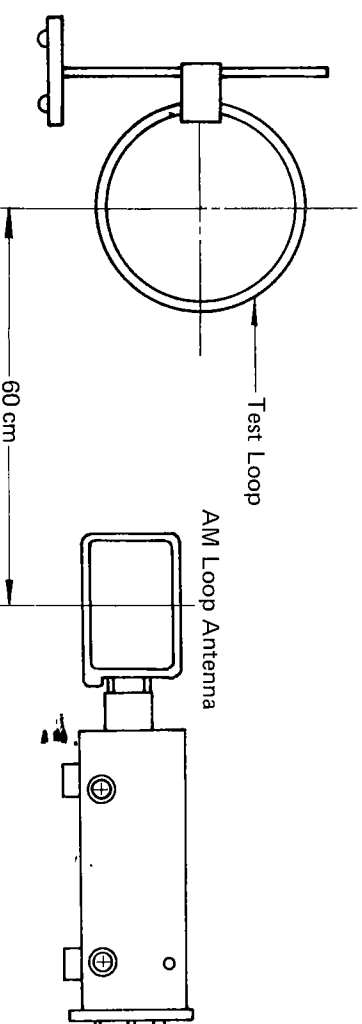
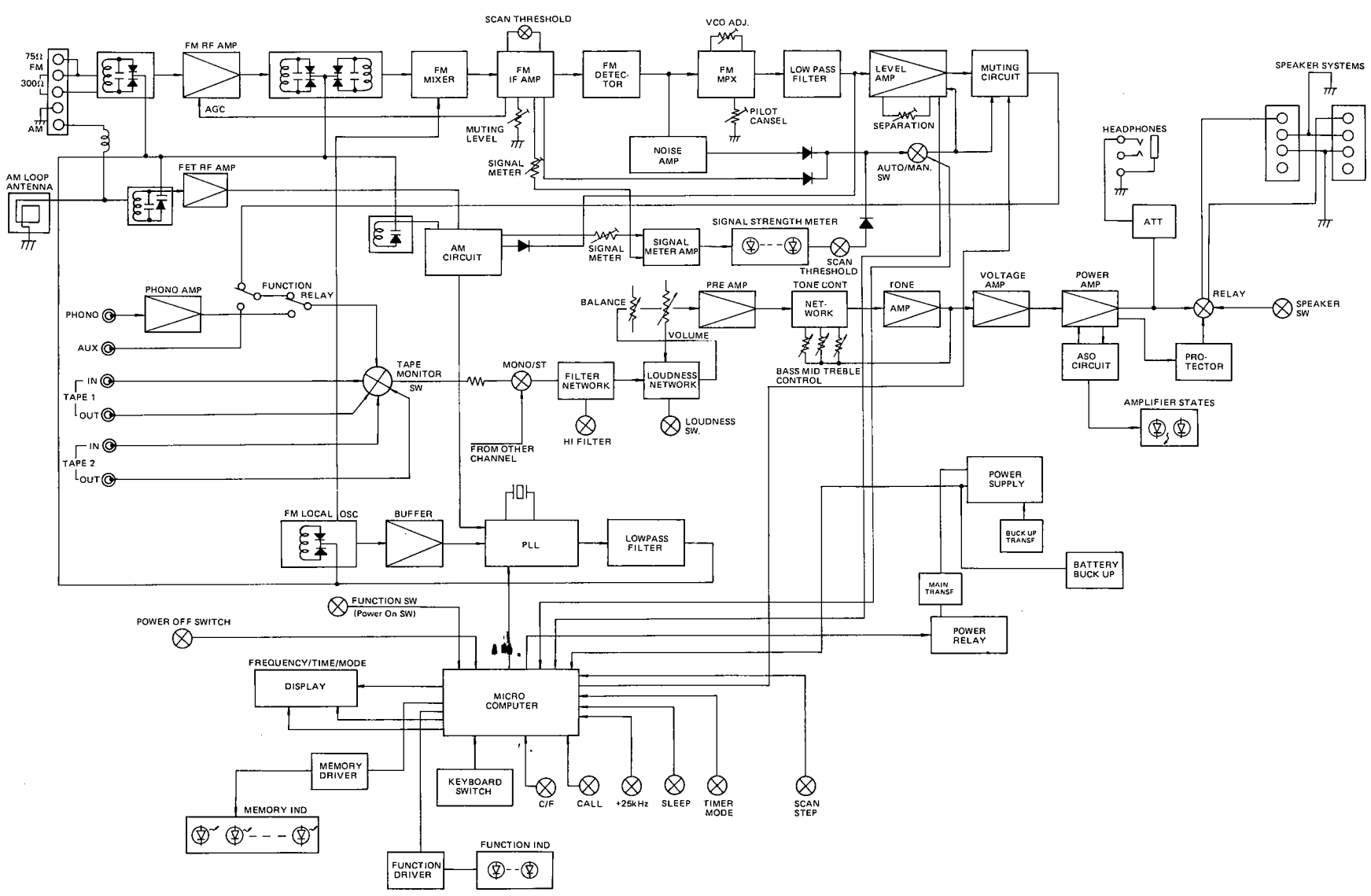

Figure 12.

6. BLOCK DIAGRAM



AGE CONVERSION
 the unit to a different power source voltage,
 position as illustrated in the drawing below.
 DISCONNECT POWER SUPPLY CORD
 FROM AC OUTLET BEFORE CONVERT-
 ING VOLTAGE. DO NOT DISASSEMBLE
 THE VOLTAGE SELECTOR ABSOLUTELY.

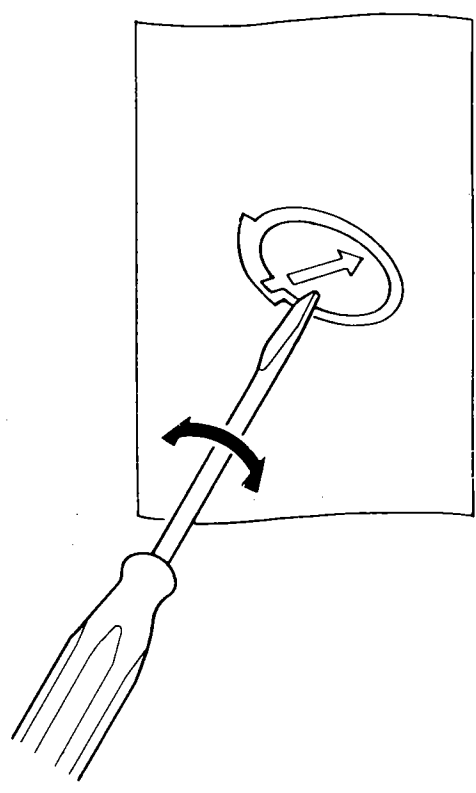

Figure 13. Voltage Conversion

SAFETY: THE PARTS MARKED WITH \triangle ARE IMPORTANT PARTS ON THE SAFETY. PLEASE USE
 THE PARTS HAVING THE DESIGNATED PARTS NUMBERS WITHOUT FAIL.

CAUTION
 for the use in the range other than specified in FTZ codes.

er die Leute, die in dem Gebiet wohnen, wo die FTZ-Bestimmungen vorherrschend sind.

Gerät auch für Frequenzen ausserhalb des in den FTZ-Bestimmungen angegebenen Bereiches empfangsbereit sein,
 den Bereich durch Nachstellen des Kernes in der Oszillatorspule (in der Abbildung mit "FTZ" gekennzeichnet) so
 en, dass er den Bestimmungen entspricht.

7. DIAGRAM AND COMPONENT LOCATIONS

7.1 Tuner/Phono Amp. (P100) Schematic Diagram and Component Locations

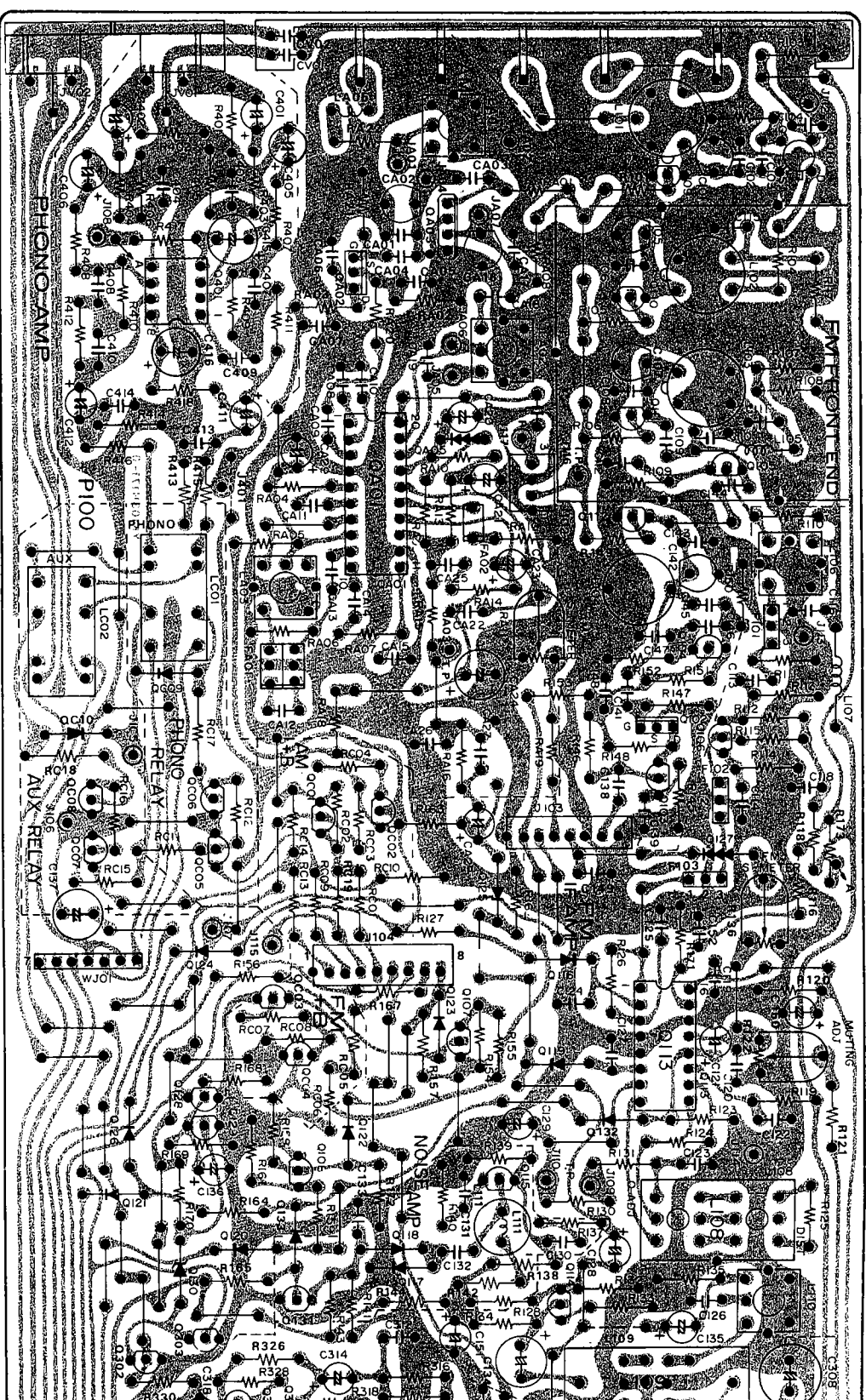
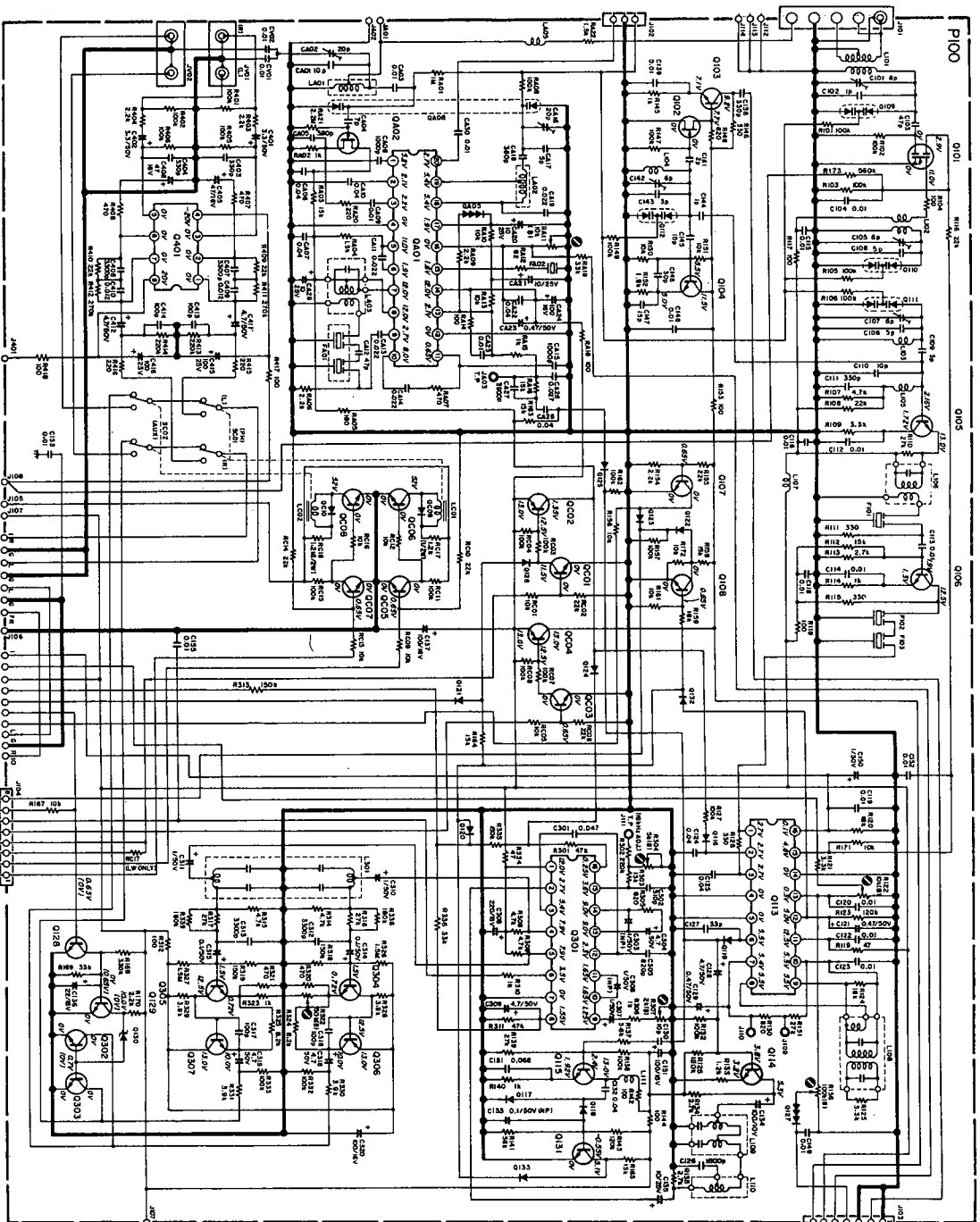

7.2 Filter/Loudness (PS00) Schematic Diagram and Component Locations

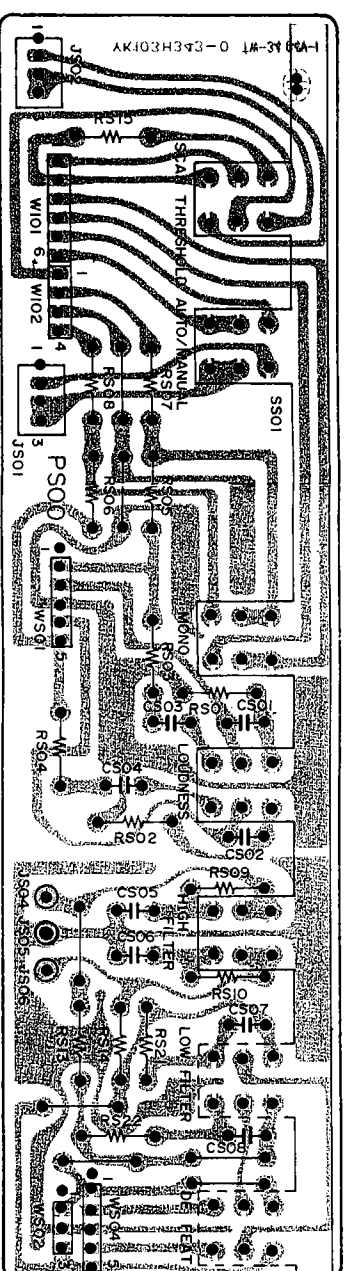
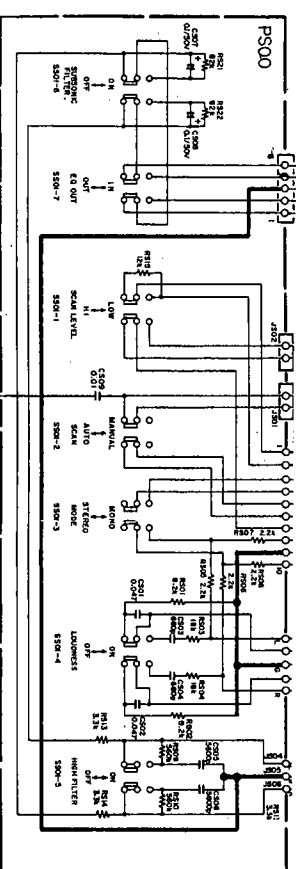

7.5 Tape Monitor Switch (P000) Schem

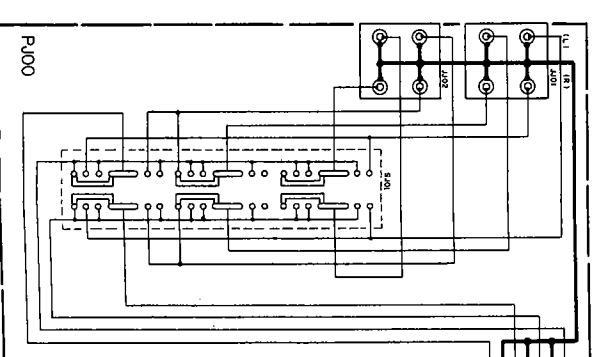

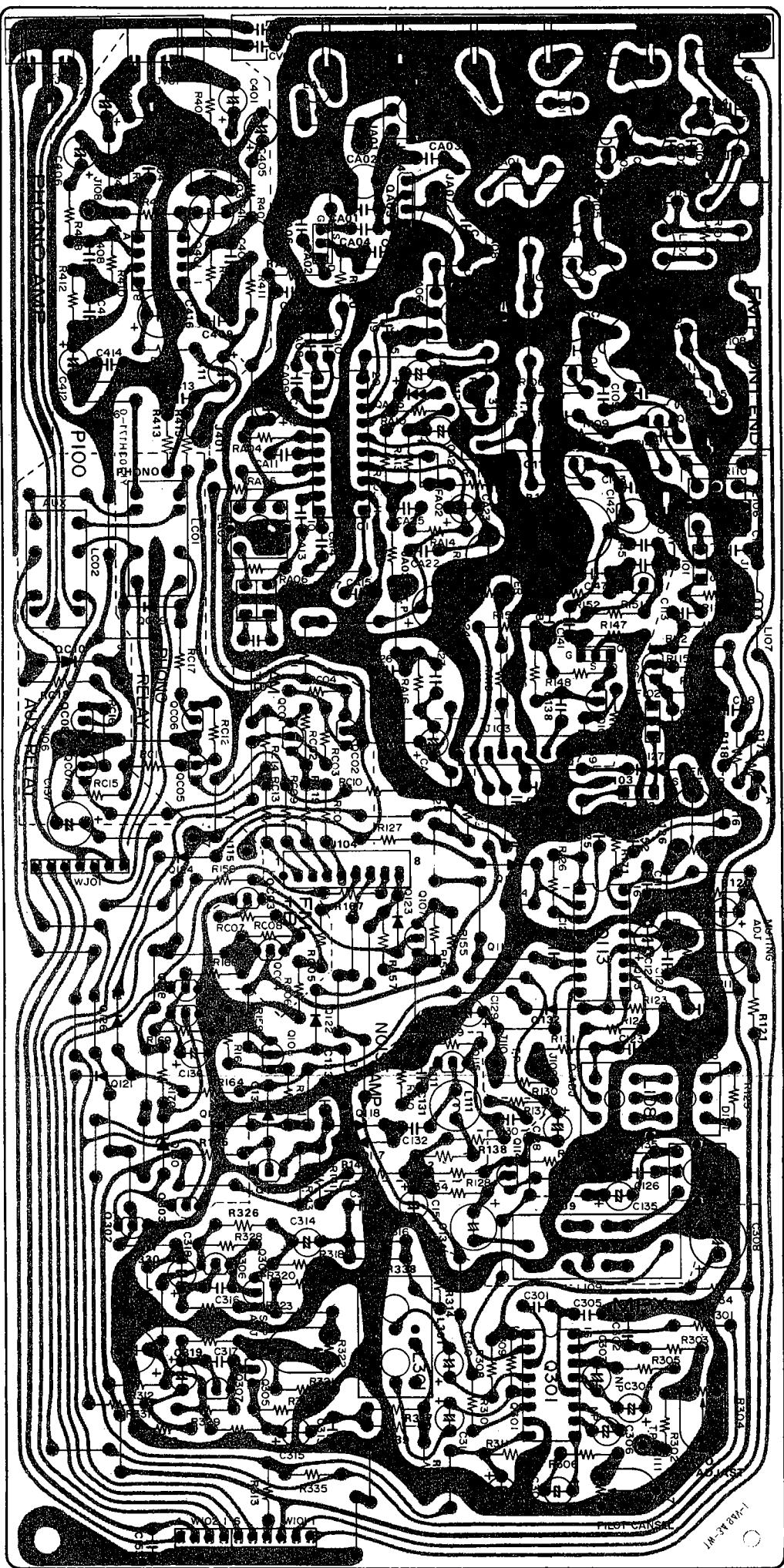
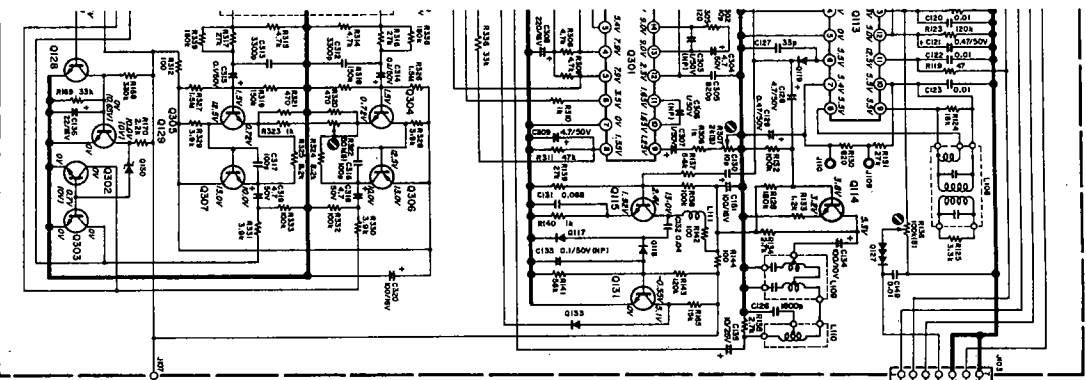

7.3 Head Phone (PW07)
Schematic Diagram and Component Locations

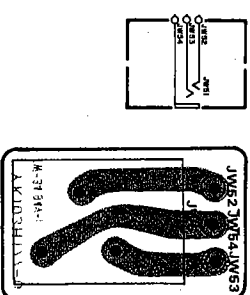

7.4 Timer Switch (PS50)
Schematic Diagram and Component Locations

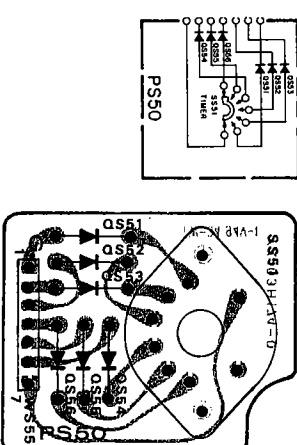

7.5 Tape Monitor Switch (P100) Schematic Diagram and Component Locations

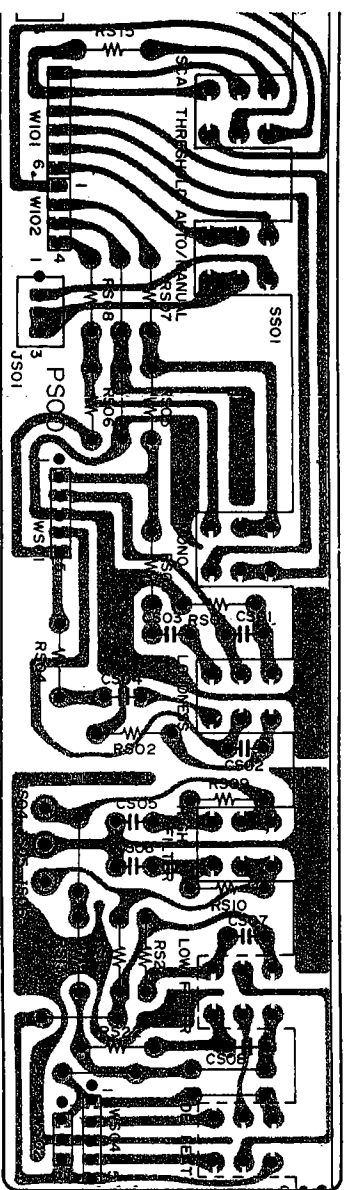
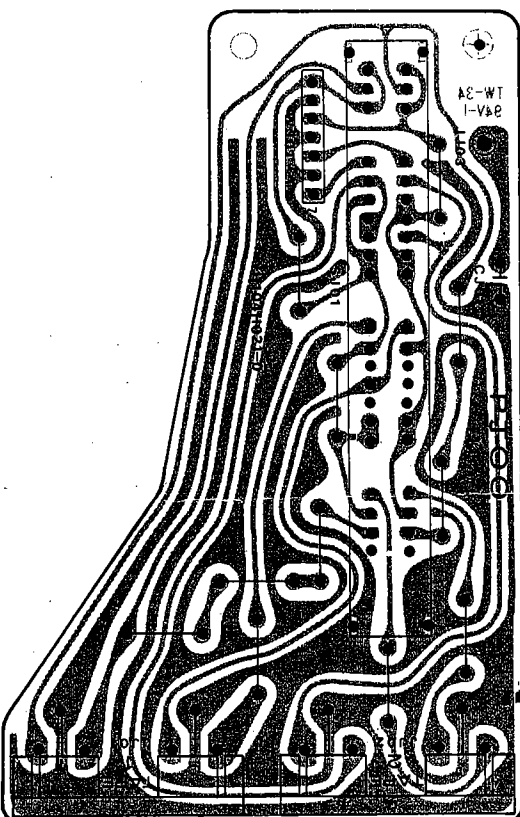
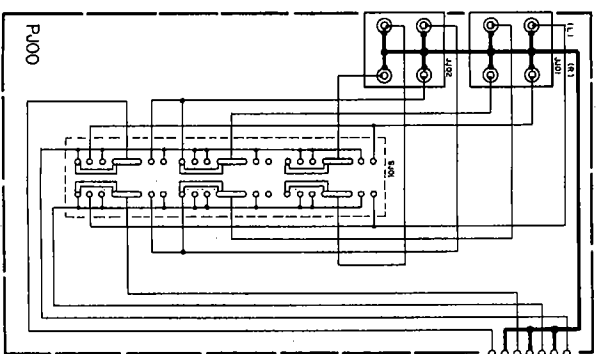

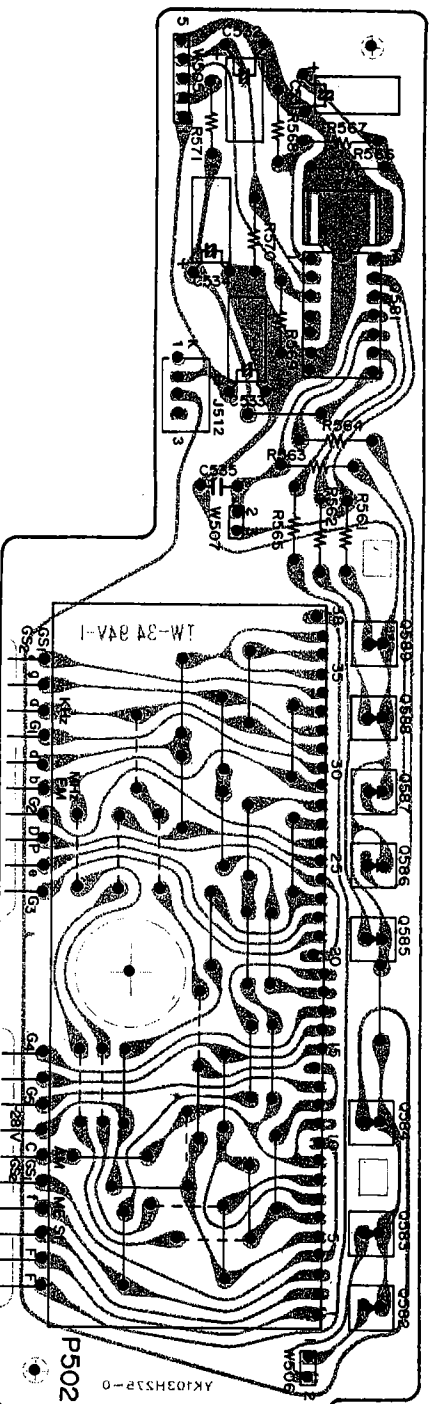
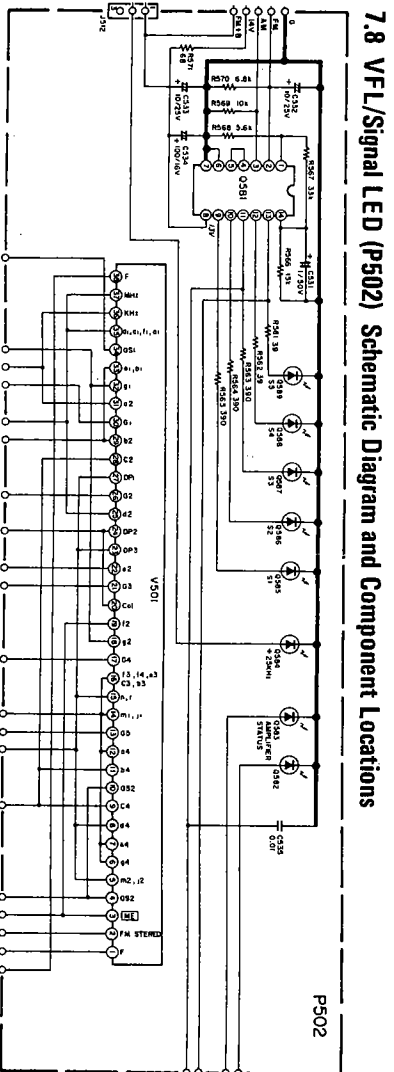
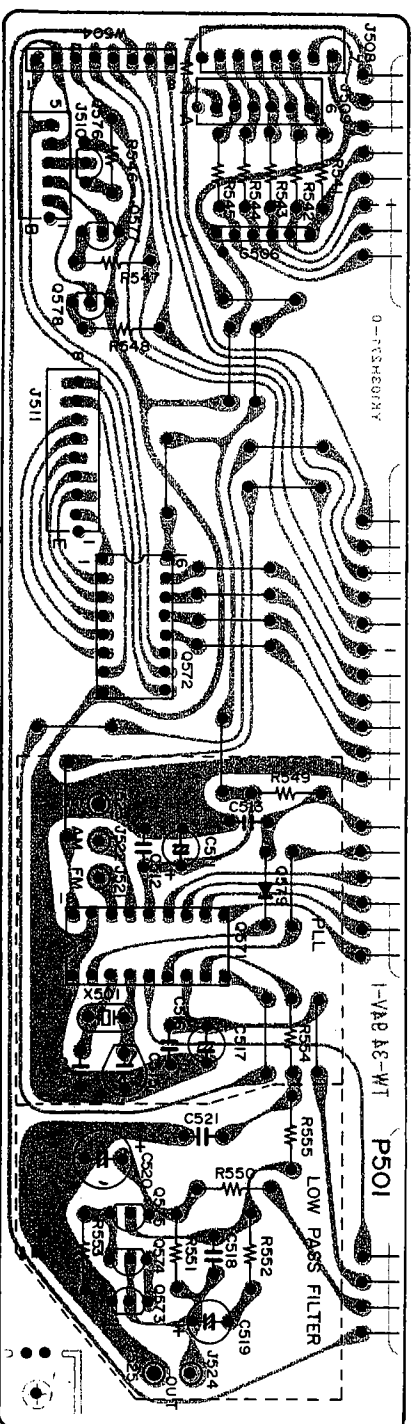
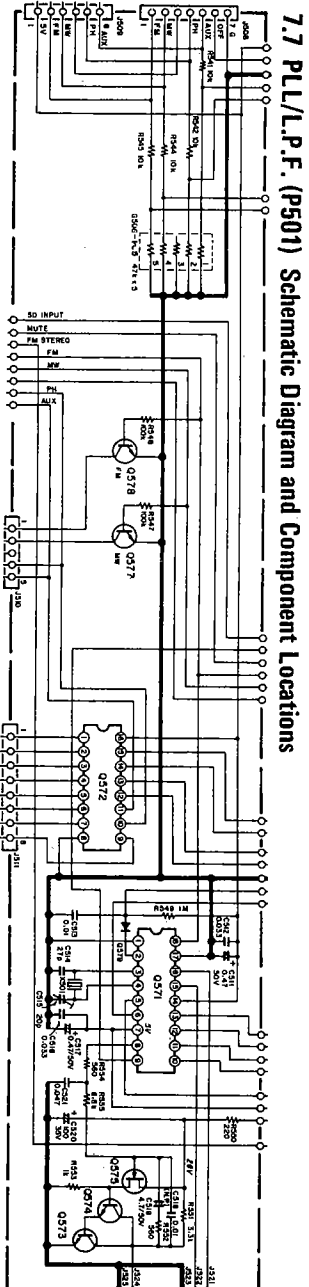
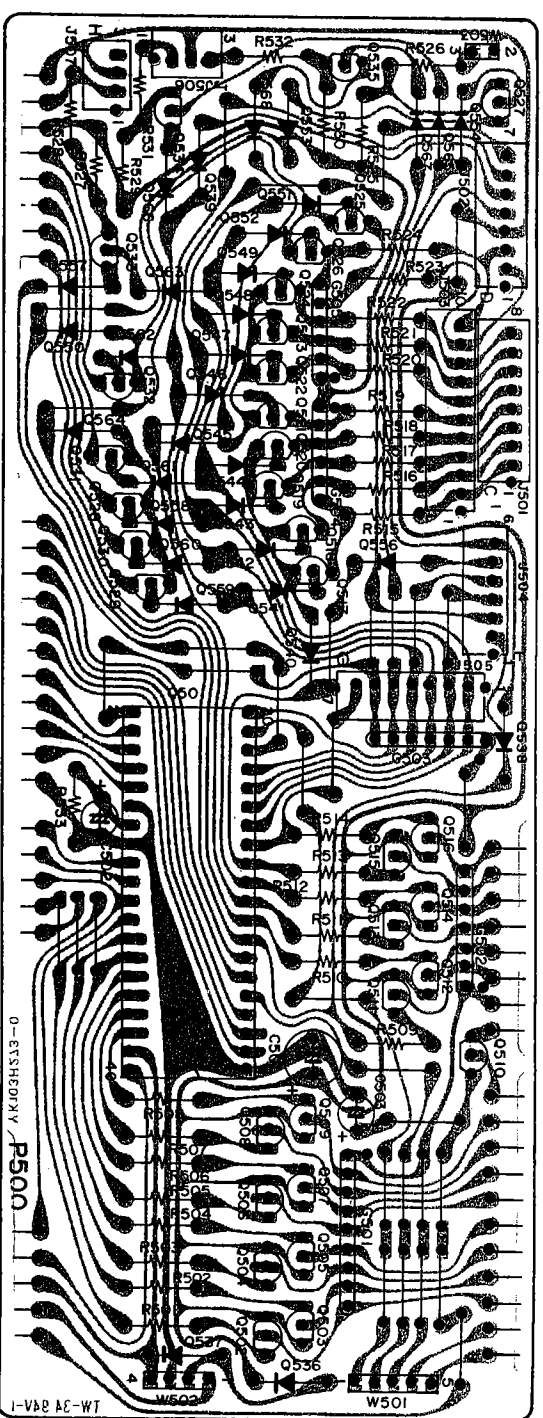
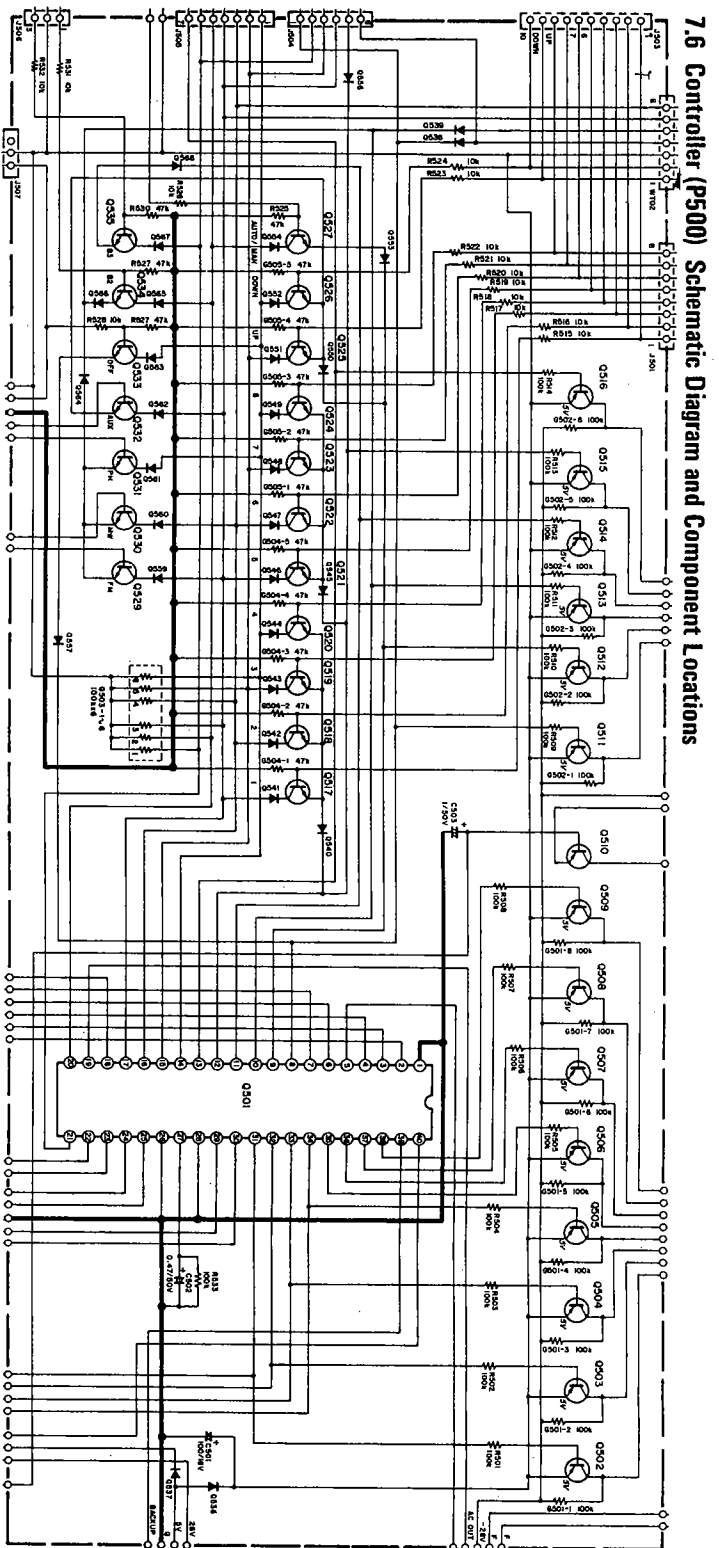

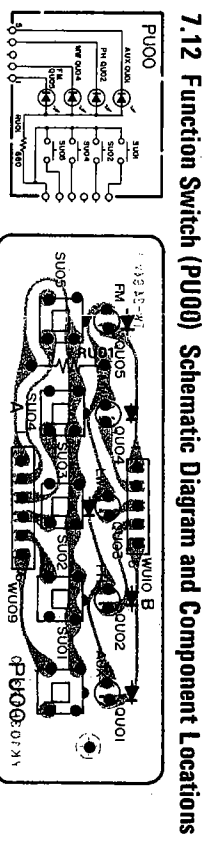
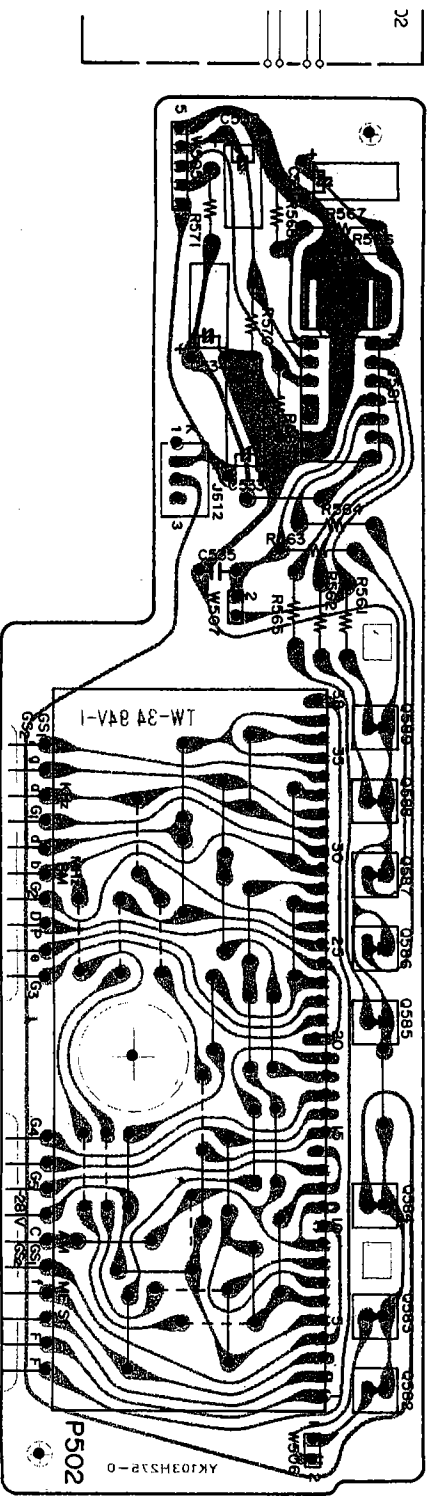
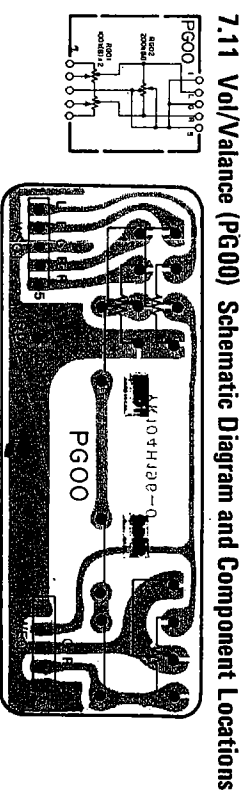
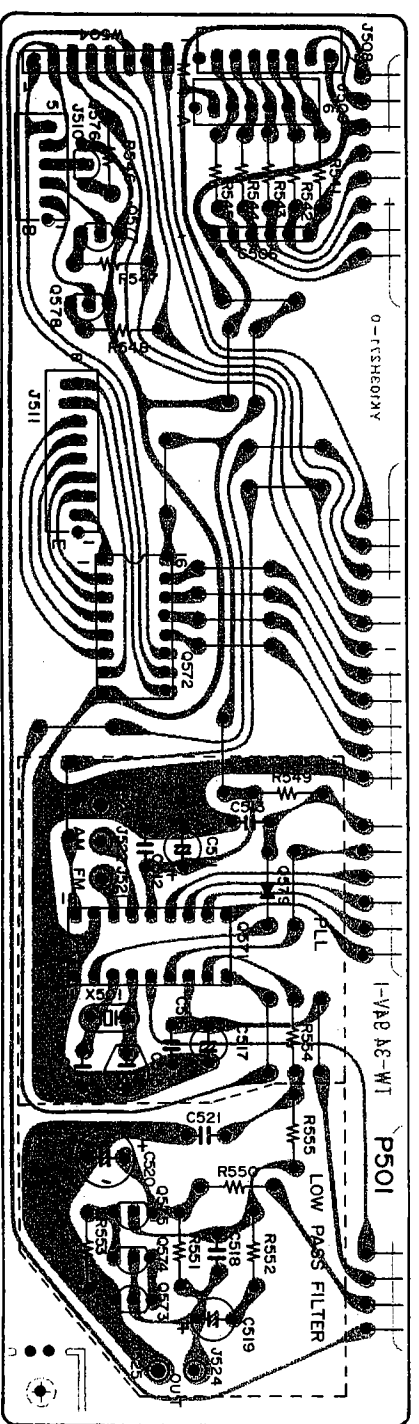
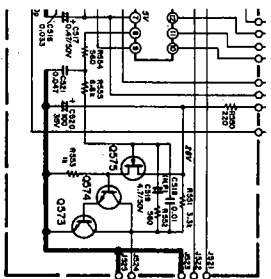
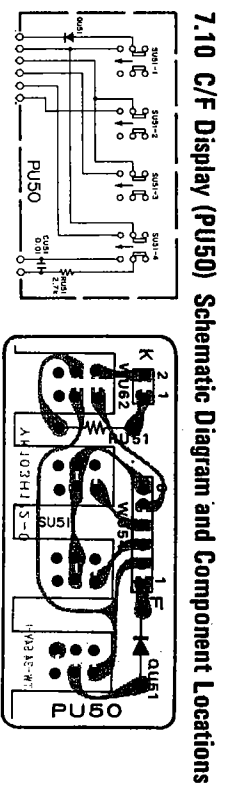
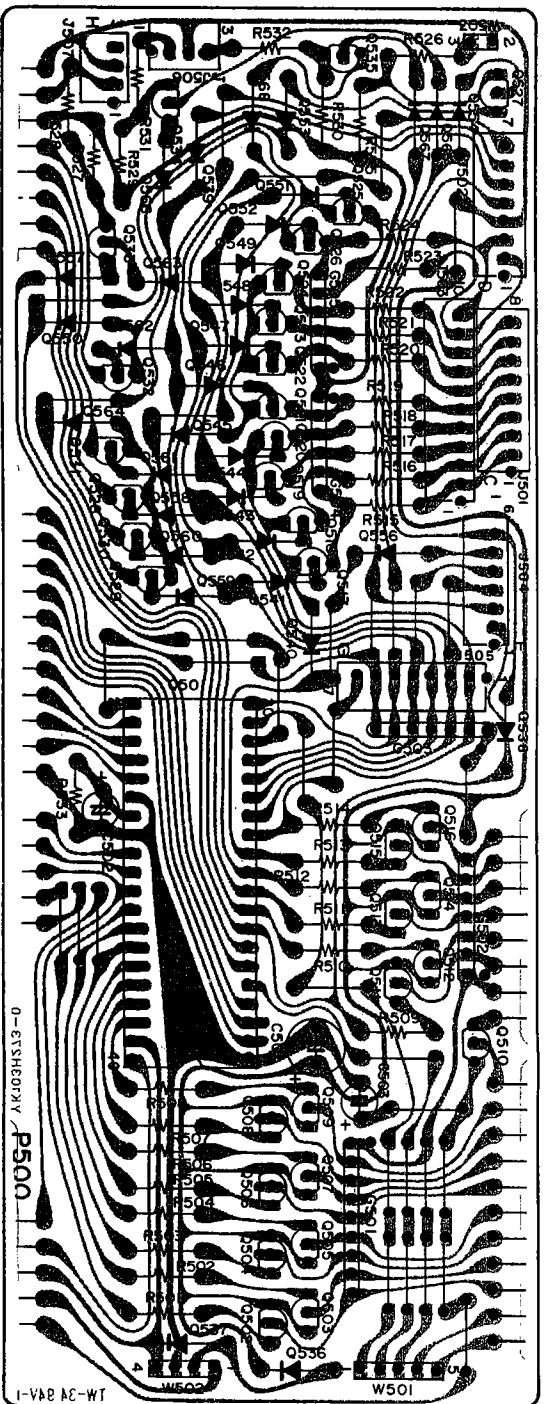
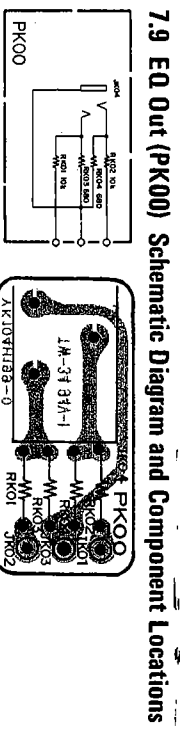
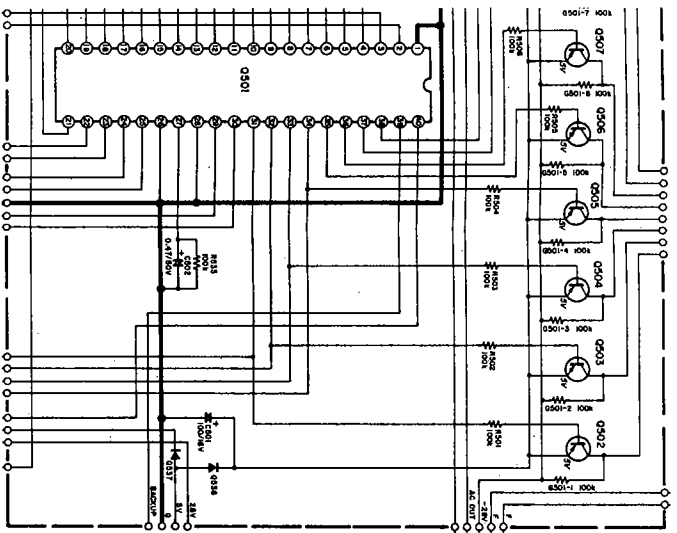

7.13 Main Amp. (P701) Schematic Diagram and Component Locations

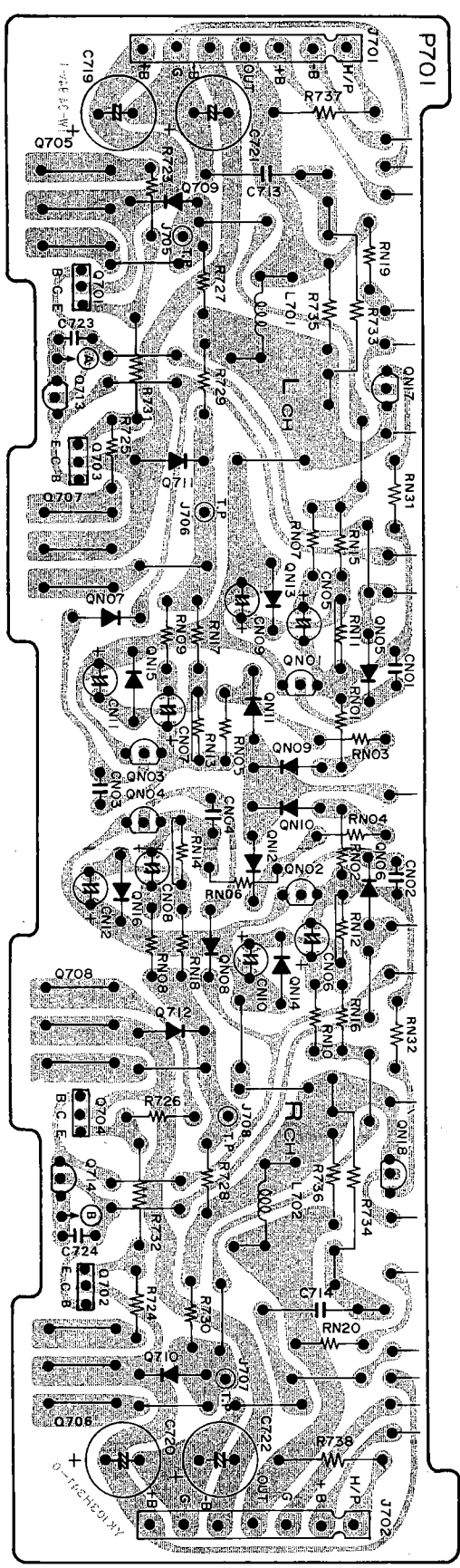
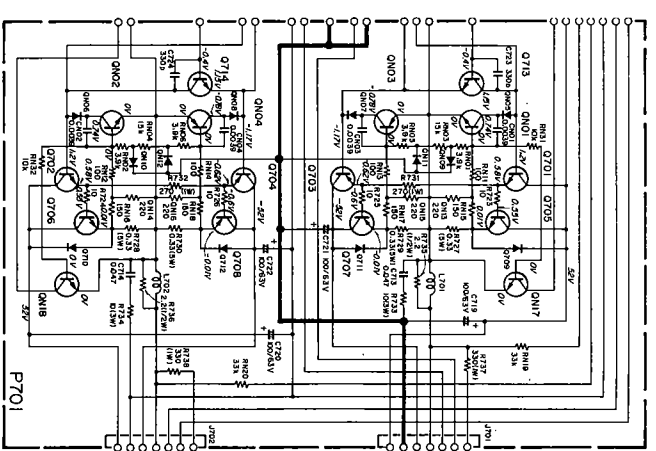

7.16 Power Off Switch (PT50) Schematic Diagram and Component Locations

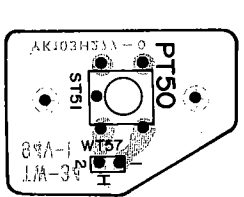
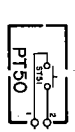

7.14 Main Amp. (P700) Schematic Diagram and Component Locations

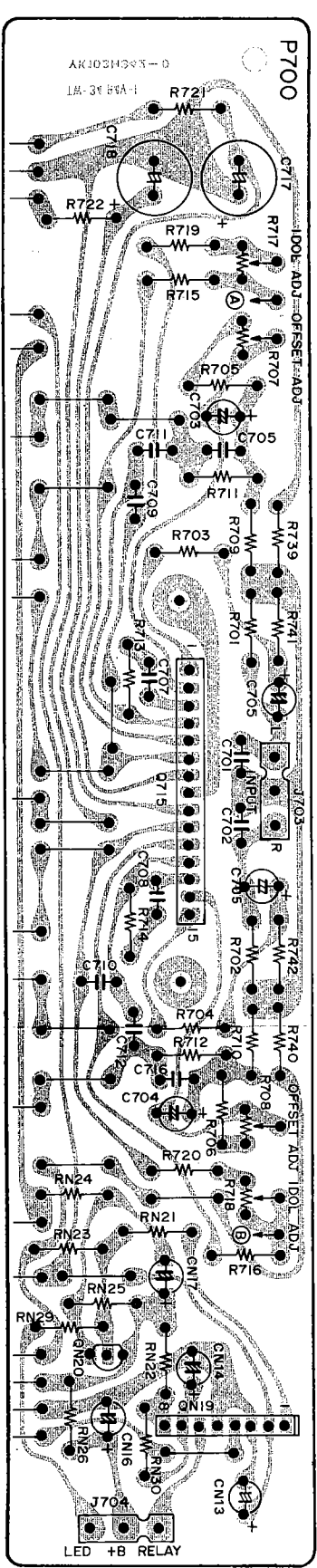
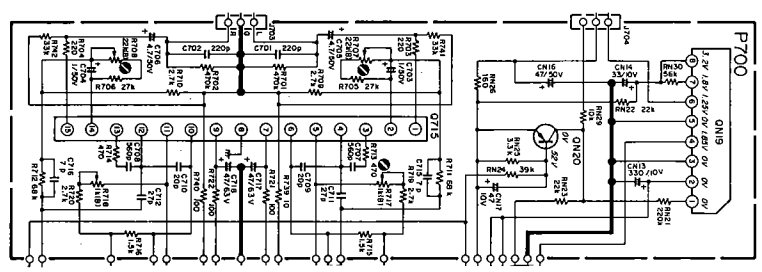

7.17 Scan Step Switch (PC50) Schematic Diagram and Component Locations

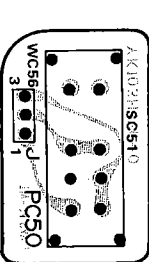
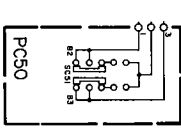

7.15 Key Board Switch (PT00) Schematic Diagram and Component Locations

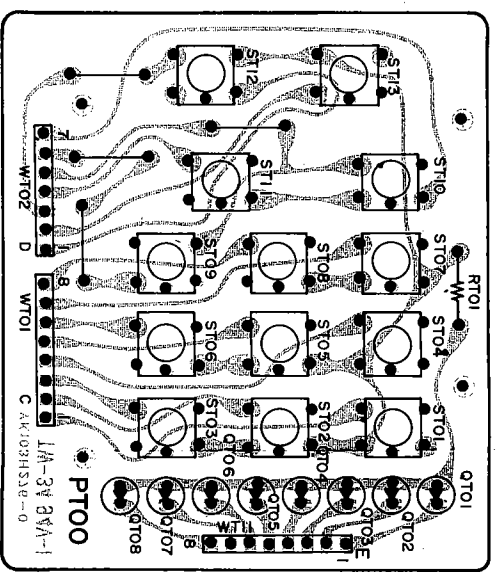
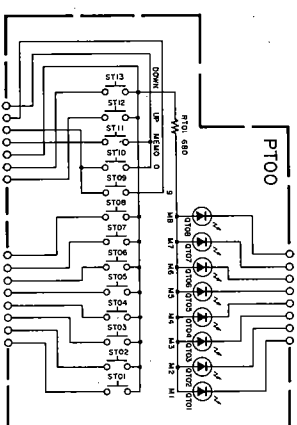

7.18 Speaker Protector (PL00) Schematic Diagram and Component Locations

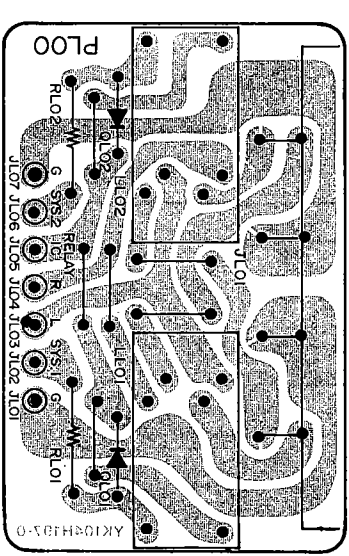
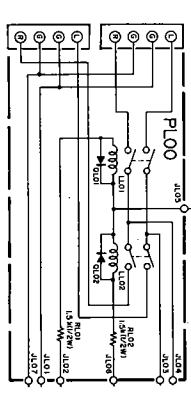

7.19 Tone Amp. (PE00) Schematic Diagram and Component Locations

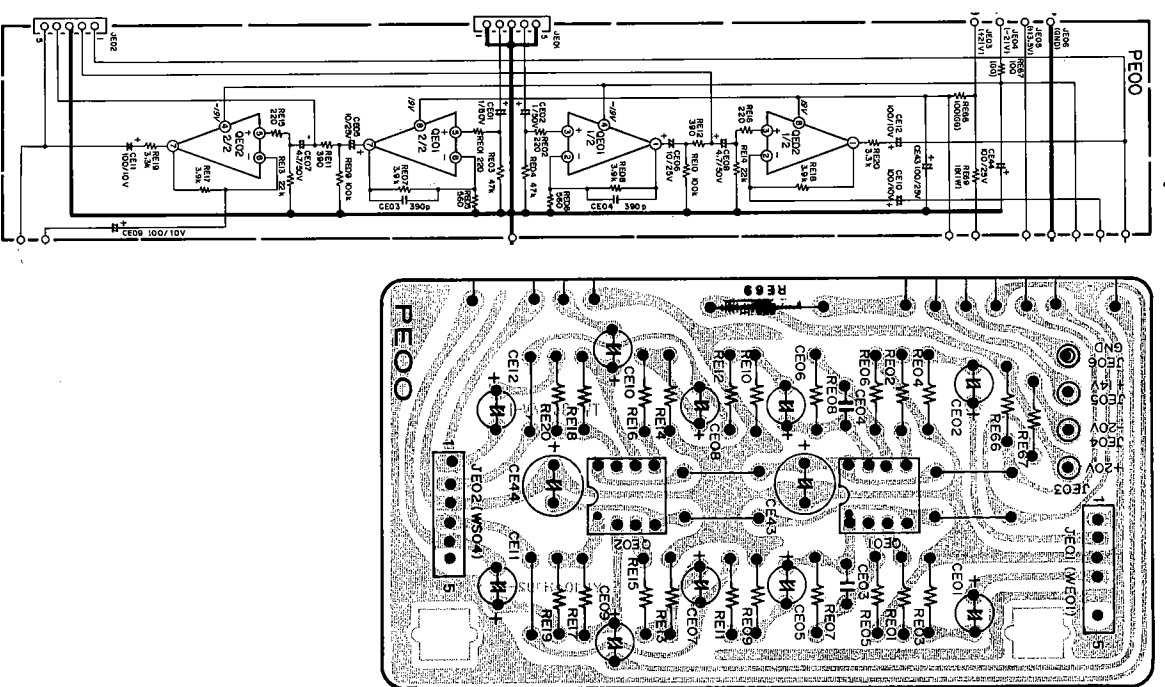

7.21 Connection (PE01) Schematic Diagram and Component Locations

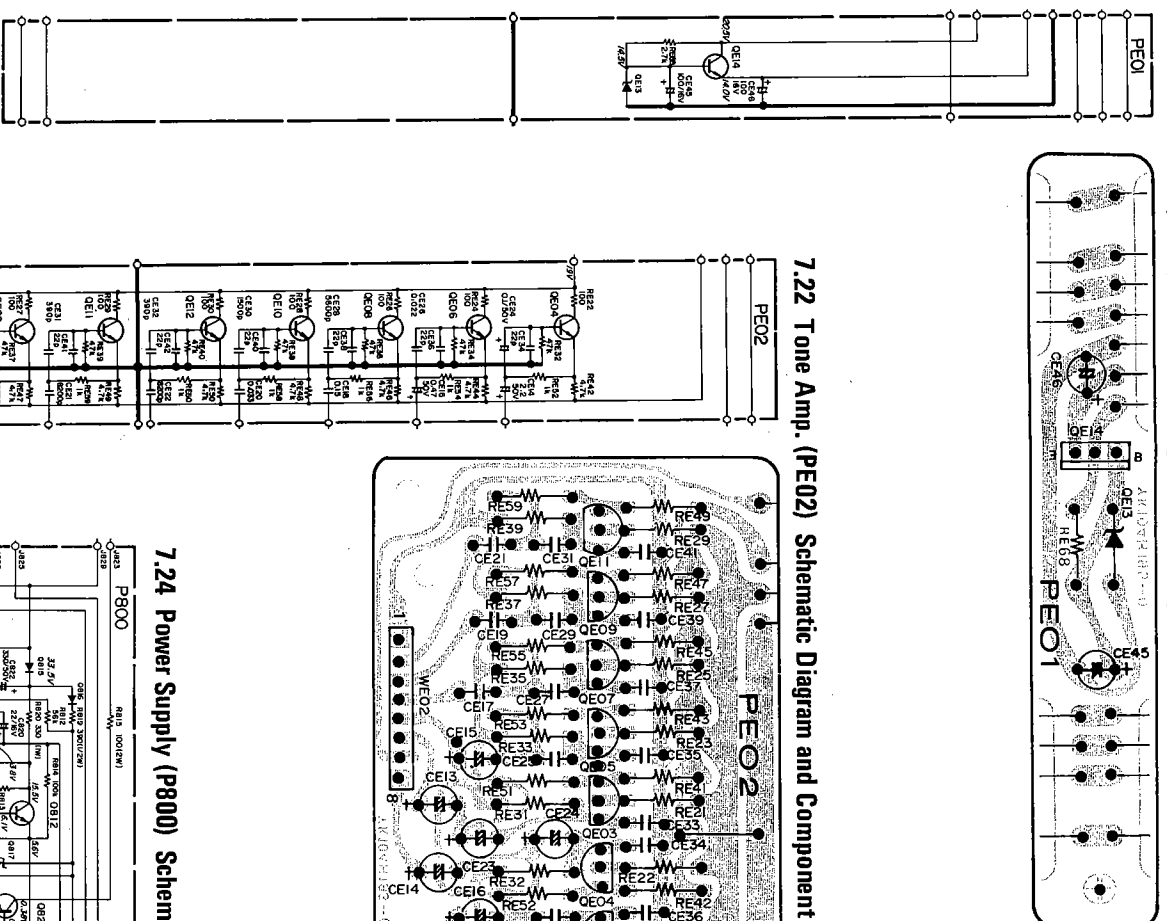

7.22 Tone Amp. (PE02) Schematic Diagram and Component Locations

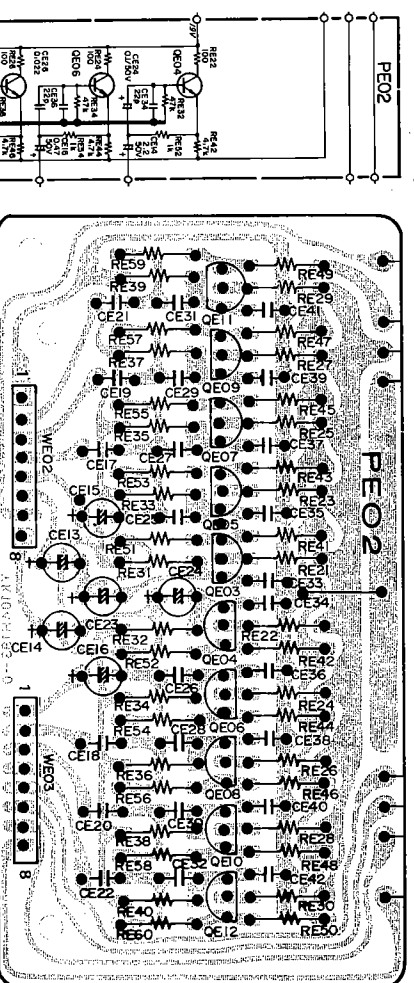

7.23 AC Power Relay (PQ00) Schematic Diagram and Component Locations

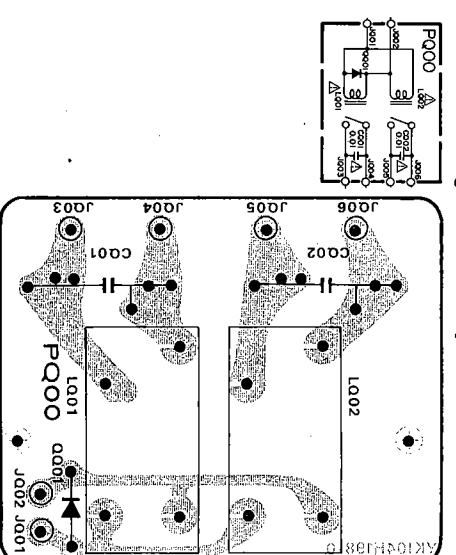

7.24 Power Supply (P800) Schematic Diagram and Component Locations

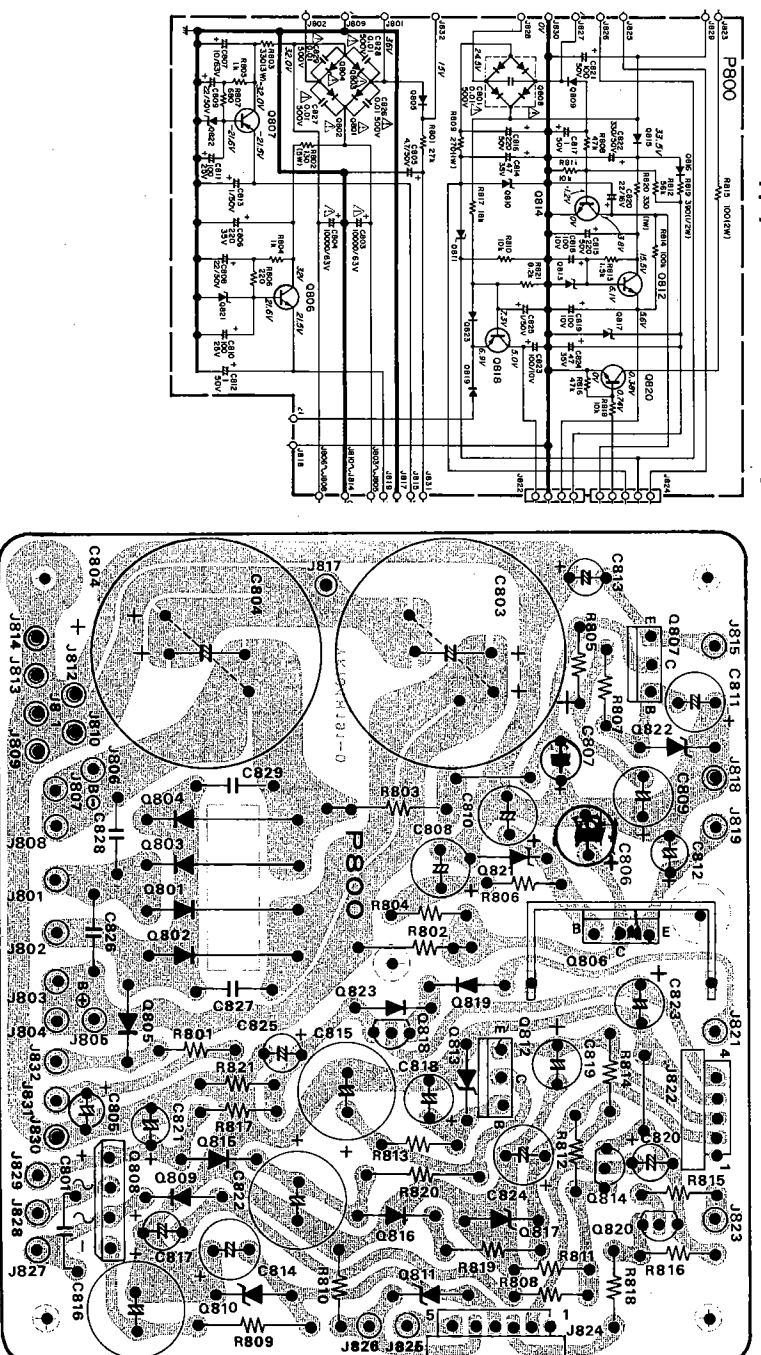

7.20 Speaker Switch (PS01) Schematic Diagram and Component Locations

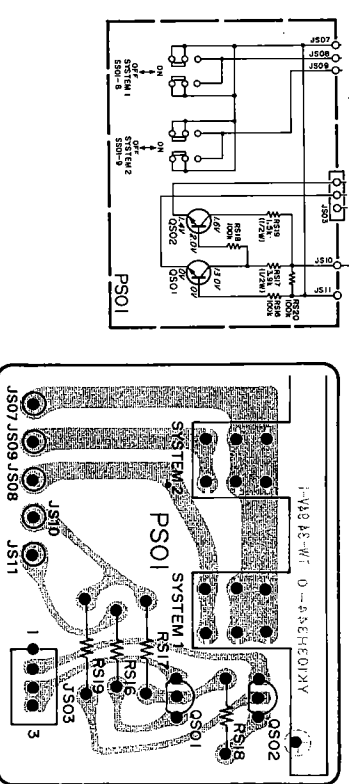

7.25 Tone Volume (PE03) Schematic Diagram and Component Locations

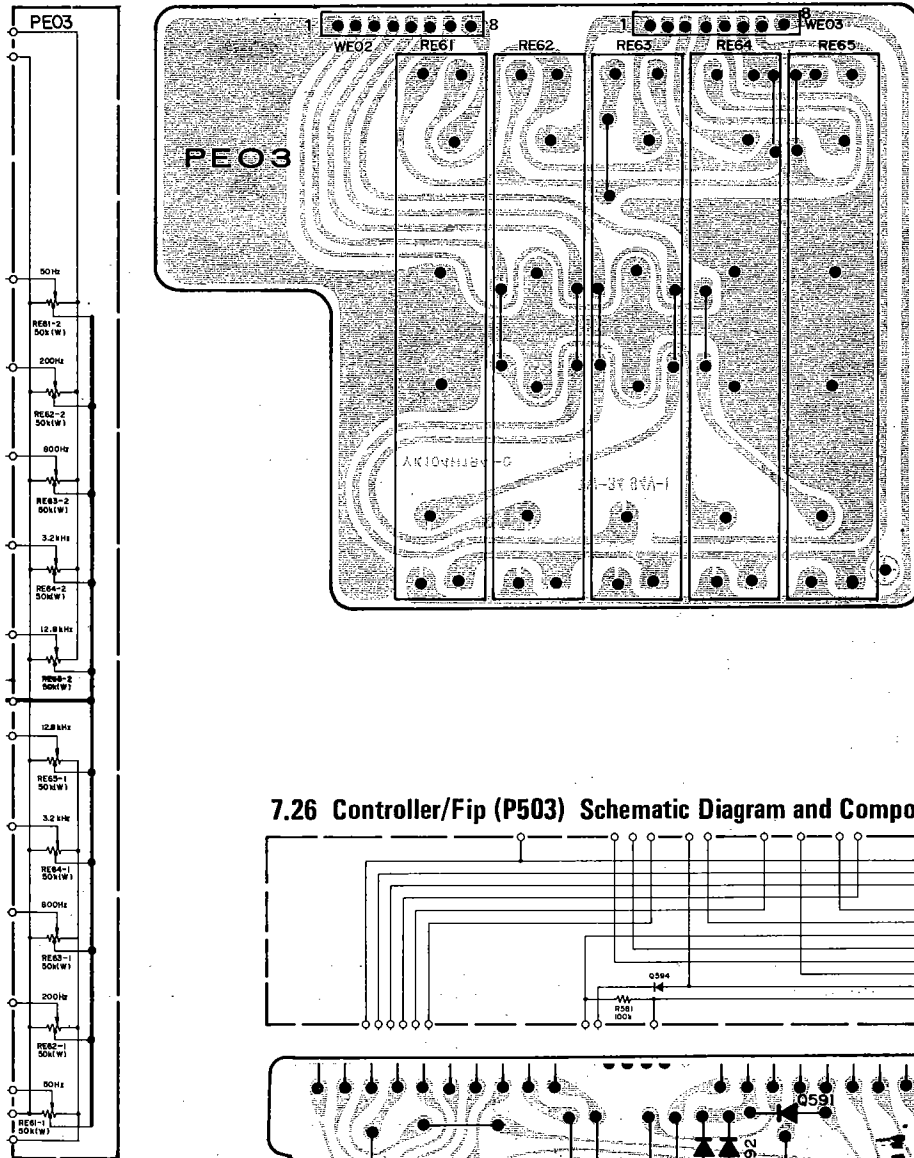

7.26 Controller/Fip (P503) Schematic Diagram and Component Locations

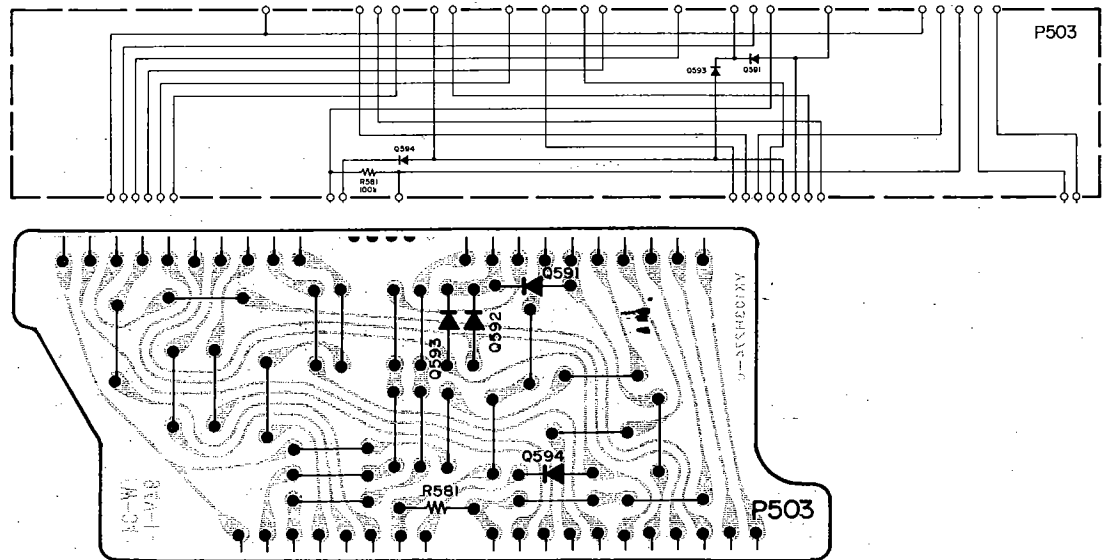

7.27 Controller/PLL (P504) Schematic Diagram and Component Locations

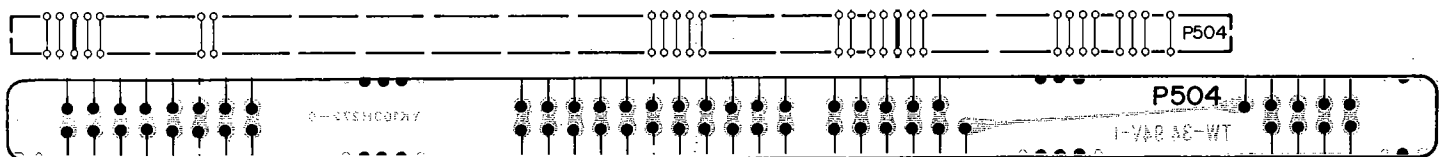

8. EXPLODED VIEW AND PARTS LIST

8.1 [C01-99] Front Panel

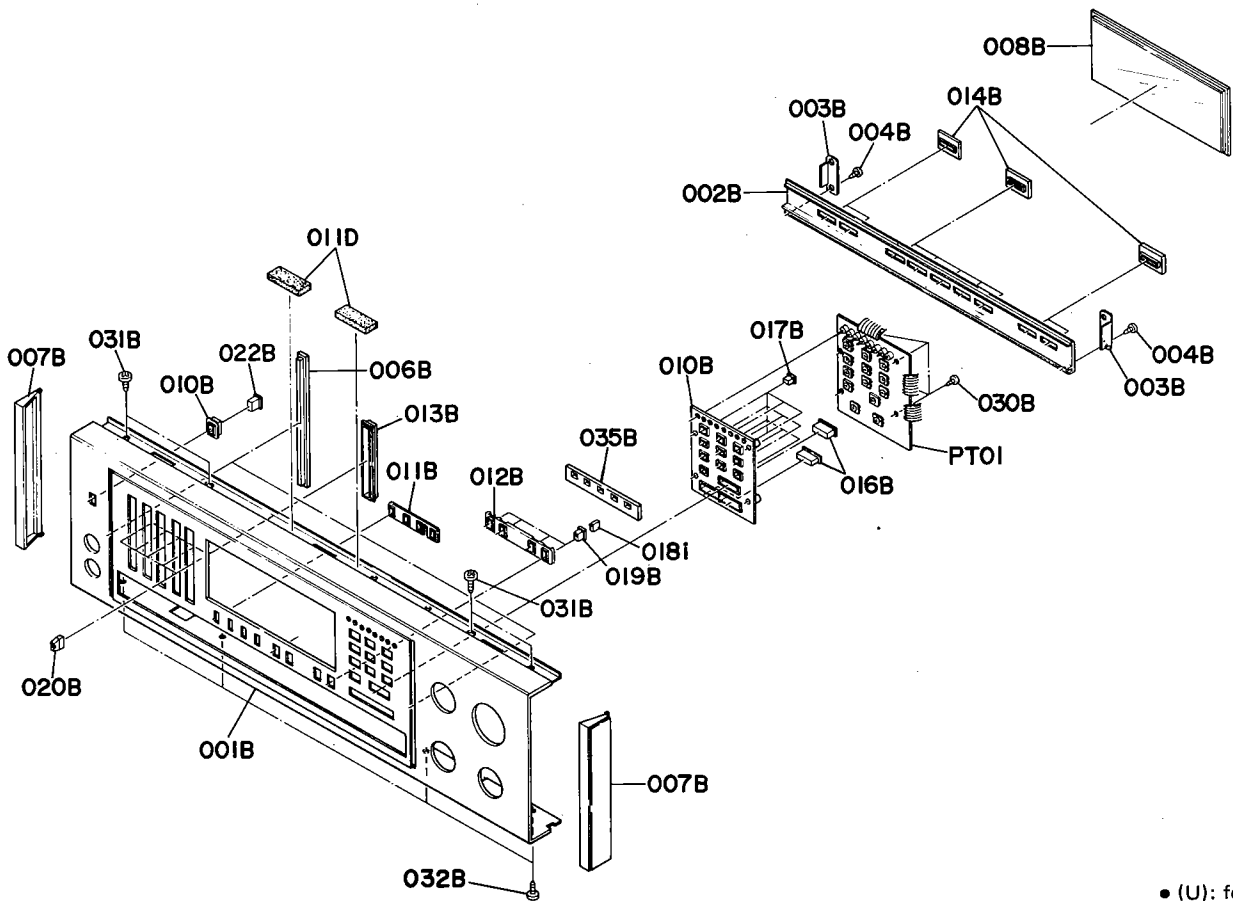

- (U): for U.S.A.
- (E): for Europe
- (P): for PX

REF. DESIG.	Q'TY			PART NO.	DESCRIPTION
	U	E	P		
A	1	1		104H063400	Front Panel Assembly
A1			1	104H063410	Front Panel Assembly
001B	1	1	1	104H063010	Escutcheon, Front Panel
002B	1	1	1	104H063050	Escutcheon, Sub Panel
003B	2	2	2	103H063030	Escutcheon, Sub Panel Side
004B	2	2	2	51280304B0	B.H. Tapped Screw B3 x 4
006B	2	2	2	211H063020	Escutcheon
007B	2	2		211H067010	Cap, Panel Side
008B	1	1	1	103H158010	Window
010B	1	1	1	103H259010	Bushing
011B	1	1	1	103H259030	Bushing
012B	1	1	1	103H259020	Bushing, Function Switch
013B	5	5	5	2129259020	Bushing, Tone Control
014B	9	9	9	208H259010	Bushing, Push Switch
035B	1	1	1	103H056010	Buffer, Function Switch

REF. DESIG.	Q'TY			PART NO.	DESCRIPTION
	U	E	P		
016B	3	3	3	103H154020	Knob, Memo/Scan
017B	10	10	10	103H154030	Knob, Preset
019B	4	4	4	103H154050	Knob, Function Switch
020B	5	5	5	2129154040	Knob, Tone Control
030B	4	4	4	51302606B0	P.H. Tapped Screw P2.6 x 6
031B	4	4	4	51280306B0	B.H. Tapped Screw B3 x 6
032B	4	4	4	51280308B0	B.H. Tapped Screw B3 x 8
022B	1	1	1	103H154030	Knob Power Off
011D	2	2		2965118010	Spacer
018i	4	4	4	103H259050	Bushing

8.2 [C02-99] Top Cover

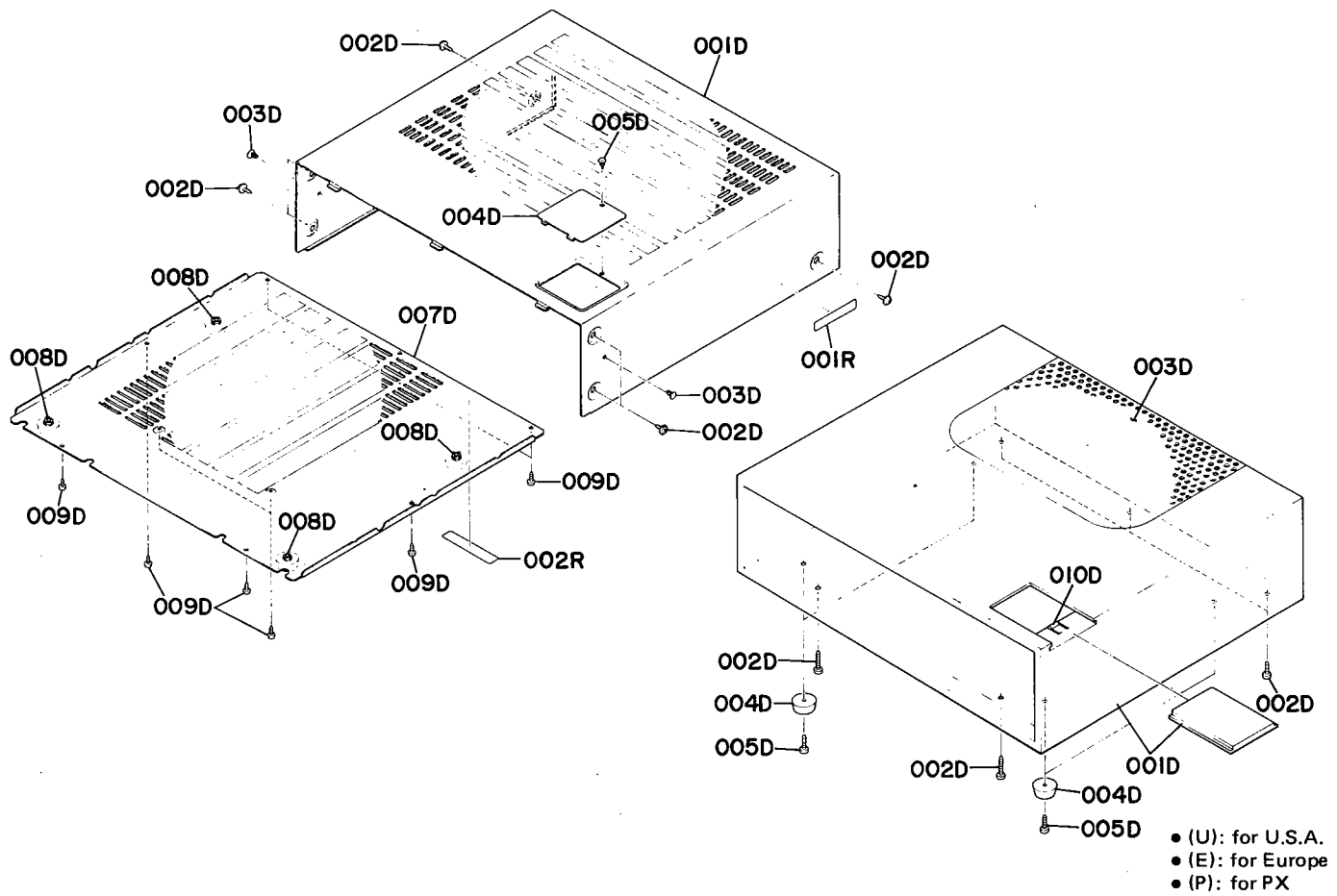

REF. DESIG.	Q'TY			PART NO.	DESCRIPTION
	U	E	P		
001D	1	1		103H257010	Lid, Top Cover
001D			1	103H064500	Case Assembly, Wood
002D	6			51260408Z0	B.T. Screw B4 x 8
002D	6			51260408U0	B.T. Screw B4 x 8
002D		5		51260320U0	B.T. Screw B3 x 20
003D	2	2		2991259110	Bushing
003D		1		2116003010	Punched Plate
004D	1	1		103H257020	Lid, Battery Cover
004D		4		2908057010	Leg
005D	1	1		2276005050	Clumper
005D		4		51524116A0	R.H. Wood Screw
007D	1	1		103H257030	Lid, Bottom Cover
007D		1		103H257030	Lid, Bottom Cover
008D	4	4		403H057010	Leg
009D	9	9		51280308B0	B.H. Tapped Screw B3 x 8
009D		4		51280308B0	B.H. Tapped Screw B3 x 8
010D	1			103H115010	Spring

REF. DESIG.	Q'TY			PART NO.	DESCRIPTION
	U	E	P		
001R	1	1	1	2932861110	Label
002R	1	1	1	2578861010	Label

8.3 [C03-99] Rear Panel

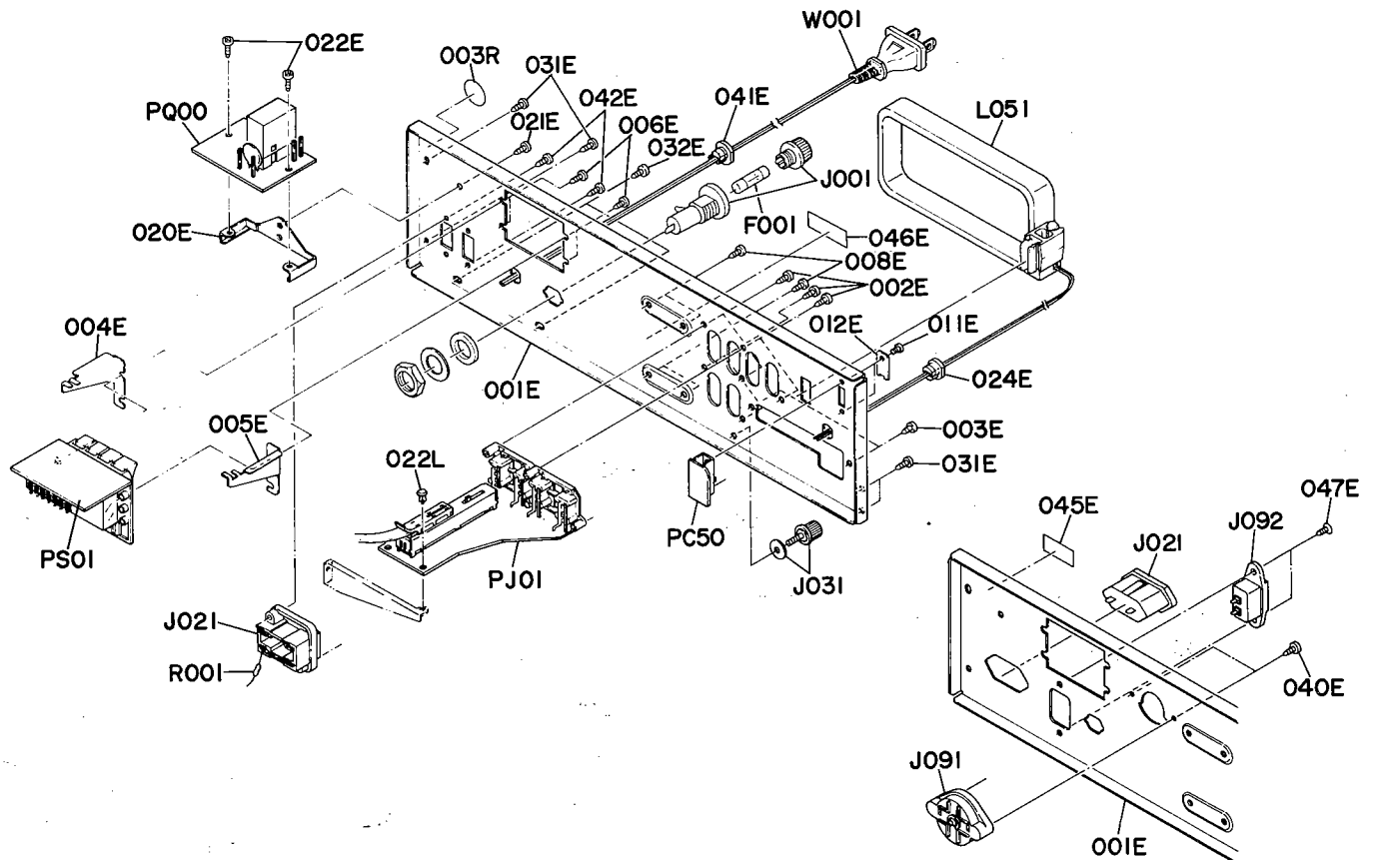

- (U): for U.S.A.
- (E): for Europe
- (P): for PX

REF. DESIG.	Q'TY			PART NO.	DESCRIPTION
	U	E	P		
001E	1			104H160210	Bracket, Rear Panel
001E		1		104H160220	Bracket, Rear Panel
001E			1	104H160230	Bracket, Rear Panel
002E	6	6	6	51280308U0	B.H. Tapped Screw B3 x 8
003E	2	2	2	51280308U0	B.H. Tapped Screw B3 x 8
004E	1	1	1	103H160060	Bracket
005E	1	1	1	103H160070	Bracket
006E	4	4	4	51280308U0	B.H. Tapped Screw B3 x 8
008E	4	4	4	51280308U0	B.H. Tapped Screw B3 x 8
011E	2	2	2	51102604S0	B.H.M. Screw B2.6 x 4
012E	1	1	1	2137114010	Stopper
020E	1	1	1	103H160040	Bracket, Relay P.W. Board
021E	1	1	1	51280308U0	B.H. Tapped Screw B3 x 8
022E	2	2	2	51280308U0	B.H. Tapped Screw B3 x 8
024E	1	1	1	1455259010	Bushing, Antenna Cord
031E	4	4	4	51280308U0	B.H. Tapped Screw B3 x 8
032E	2	2	2	51280308U0	B.H. Tapped Screw B3 x 8
040E		2	2	51280308U0	B.H. Tapped Screw B3 x 8
041E	1		1	1455259030	Bushing, AC Cord
042E	2		2	51280310U0	B.H. Tapped Screw B3 x 10
045E		1		4581861010	Label
046E	1	1	1	2112265010	Indicator
047E		2		51870308U0	Screw 3 x 8
003R	1			9511101070	Label, UL

REF. DESIG.	Q'TY			PART NO.	DESCRIPTION
	U	E	P		
Δ F001	1			FS10500500	Fuse 5A 250V
Δ F001		1		FS10250800	Fuse 2.5A 250V
Δ F001			1	FS10500600	Fuse 5A 250V
Δ J001	1			YJ08000310	Jack, Fuse Holder
Δ J001		1		YJ08000290	Jack, Fuse Holder
Δ J001			1	YJ08000300	Jack, Fuse Holder
Δ J021	1	1	1	YJ04000750	Jack, AC Outlet
Δ J021		1		YJ04000850	Jack, AC Outlet
J031	1	1	1	YL03010250	Terminal, Ground
Δ J091	1	1		BY05080040	Voltage Selector
Δ J092		1		YP04000590	Plug, AC Inlet
L051	1	1	1	LA00015010	Antenna Coil, Loop
R001	1			RC10225120	Resistor 2.2MΩ ±10% 1/2W
Δ W001	1			YC01900070	A.C. Power Cord
Δ W001			1	YC01800190	A.C. Power Cord

8.4 [P01-99] Chassis and General Parts

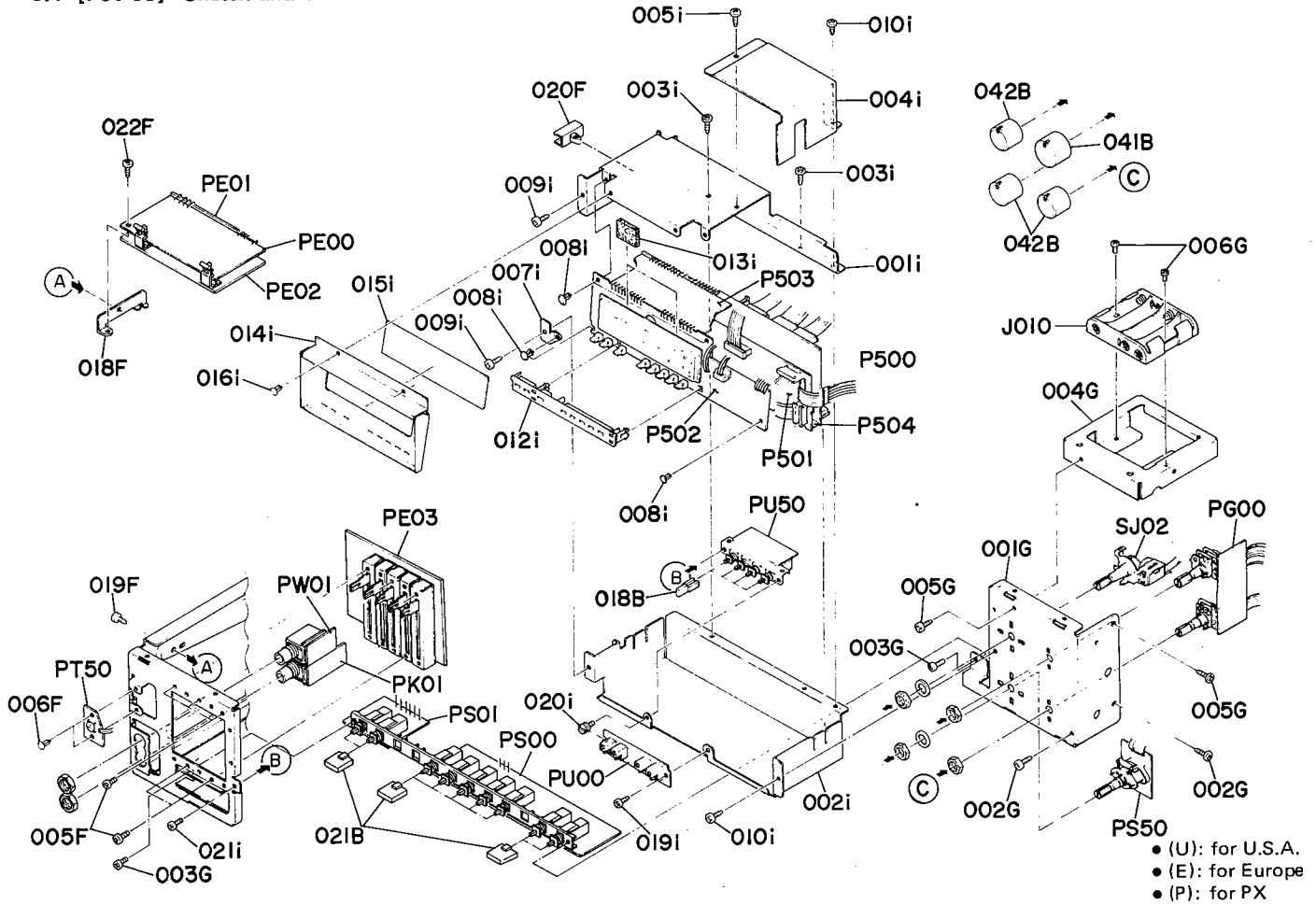

REF. DESIG.	Q'TY			PART NO.	DESCRIPTION
	U	E	P		
018B	4	4	4	103H154040	Knob
021B	9	9	9	208H154060	Knob, Push Switch
041B	1	1	1	103H154010	Knob, Volume
042B	3	3	3	208H154020	Knob
005F	5	5	5	51100306A9	B.H.M. Screw B3 x 6
006F	2	2	2	2276005050	Clamper
017F	2	2	2	2139271020	Holder
018F	1	1	1	104H160030	Bracket
019F	1	1	1	51280308B0	B.H. Tapped Screw B3 x 8
020F	1	1	1	2218271020	Holder
022F	1	1	1	51260308B0	B.T. Screw B3 x 8
001G	1	1	1	103H160010	Bracket, Front Shassis
002G	2	2	2	51280308B0	B.H. Tapped Screw B3 x 8
003G	2	2	2	51100306A9	B.H.M. Screw B3 x 6
004G	1	1	1	103H160020	Bracket, Battery Case
005G	2	2	2	51280308B0	B.H. Tapped Screw B3 x 8
006G	2	2	2	51302606T0	P.H. Tapped Screw P2.6 x 6

REF. DESIG.	Q'TY			PART NO.	DESCRIPTION
	U	E	P		
001i	1	1	1	103H109010	Shield, Top
002i	1	1	1	103H109020	Shield, Bottom
003i	2	2	2	51280308B0	B.H. Tapped Screw B3 x 8
004i	1	1	1	103H109040	Shield
005i	1	1	1	51280306B0	B.H. Tapped Screw B3 x 6
007i	1	1	1	103H160090	Bracket
008i	4	4	4	2276005050	Clamper
009i	2	2	2	51280308B0	B.H. Tapped Screw B3 x 8
010i	2	2	2	51280308B0	B.H. Tapped Screw B3 x 8
012i	1	1	1	103H259040	Bushing, LED
013i	2	2	2	2137118010	Spacer
014i	1	1	1	103H302020	Dial
015i	1	1	1	2137158020	Window
016i	2	2	2	2912259020	Bushing
019i	1	1	1	51280306B0	B.H. Tapped Screw B3 x 6
020i	1	1	1	103H101010	Support
021i	1	1	1	51100306A9	B.H.M. Screw B3 x 6
J010	1	1	1	YJ14000060	Battery Case
SJ02	1	1	1	SR00050100	Rotary Switch, Tape Monitor

8.5 [P02-99] P.W. Board and Other Parts

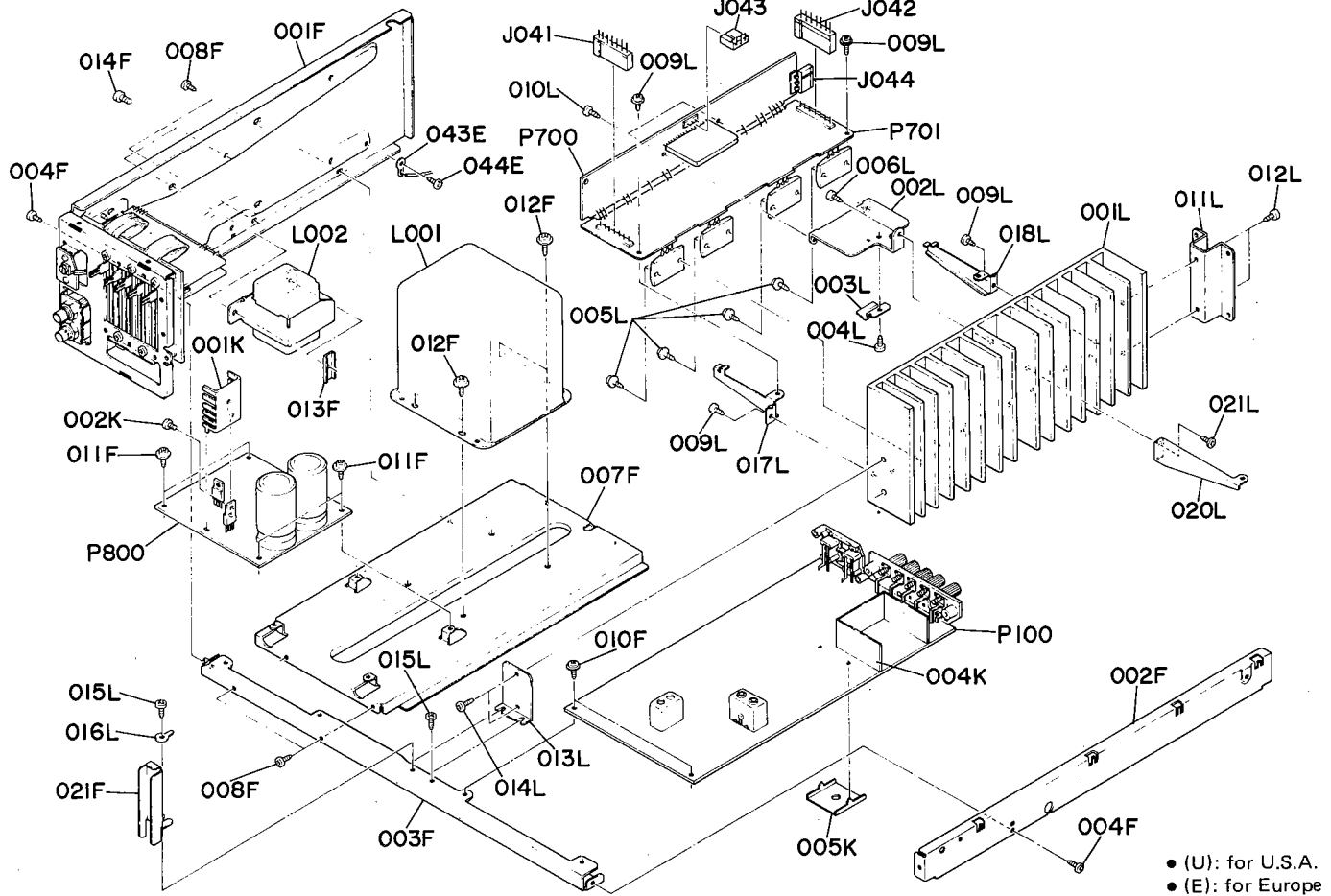

• (U): for U.S.A.
 • (E): for Europe
 • (P): for PX

REF. DESIG.	Q'TY			PART NO.	DESCRIPTION
	U	E	P		
043E	1	1	1	62030049W0	Lug
044E	1	1	1	51280308B0	B.H. Tapped Screw B3 x 8
001F	1	1	1	103H105020	Chassis, (L)
002F	1	1	1	103H126010	Stay, (R)
003F	1	1	1	103H126020	Stay, Center
004F	2	2	2	51280308B0	B.H. Tapped Screw B3 x 8
007F	1	1	1	104H105010	Chassis
008F	4	4	4	51280308B0	B.H. Tapped Screw B3 x 8
010F	2	2	2	51260308B0	B.T. Screw B3 x 8
011F	4	4	4	51280306B0	B.H. Tapped Screw B3 x 6
012F	4	4	4	51280410B0	B.H. Tapped Screw B3 x 8
013F	2	2	2	2922005010	Clamper
014F	2	2	2	51100408A9	B.H.M. Screw B4 x 8
021F	1	1	1	103H160130	Bracket
001L	1	1	1	104H267010	Heatsink, Main
002L	1	1	1	103H267020	Heatsink
003L	1	1	1	2116115010	Spring
004L	1	1	1	51280308B0	B.H. Tapped Screw B3 x 8
005L	8	8	8	51280312B0	B.H. Tapped Screw B3 x 12
006L	1	1	1	51280310B0	B.H. Tapped Screw B3 x 10
009L	2	2	2	51280306B0	B.H. Tapped Screw B3 x 6
010L	2	2	2	51280308B0	B.H. Tapped Screw B3 x 8
011L	1	1	1	103H160100	Bracket

REF. DESIG.	Q'TY			PART NO.	DESCRIPTION
	U	E	P		
012L	2	2	2	51280308B0	B.H. Tapped Screw B3 x 8
013L	1	1	1	2276160040	Bracket
014L	2	2	2	51280308B0	B.H. Tapped Screw B3 x 8
015L	2	2	2	51280308B0	B.H. Tapped Screw B3 x 8
016L	1	1	1	62030049W0	Lug
017L	1	1	1	104H160010	Bracket
018L	1	1	1	104H160020	Bracket
019L	2	2	2	51260308B0	B.T. Screw B3 x 8
020L	1	1	1	104H160040	Bracket
021L	1	1	1	51280308B0	B.H. Tapped Screw B3 x 8
001K	1	1	1	202H267030	Heatsink
002K	1	1	1	51280308B0	B.H. Tapped Screw B3 x 8
004K	1	1	1	2137109010	Shield
005K	1	1	1	2850109020	Shield
J041	1	1	1	YJ06001060	Jack, (7P)
J042	1	1	1	YJ06001060	Jack, (7P)
J043	1	1	1	YJ06001240	Jack, (3P)
J044	1	1	1	YJ06001240	Jack, (3P)
△ L001	1			TS18505090	Power Transformer
△ L001		1		TS18505100	Power Transformer
△ L001			1	TS18505110	Power Transformer
△ L002	1			TS14808350	Power Transformer, Back up
△ L002		1		TS15405080	Power Transformer, Back up
△ L002			1	TS15405100	Power Transformer, Back up

8.6 [H01-99] Packing Materials

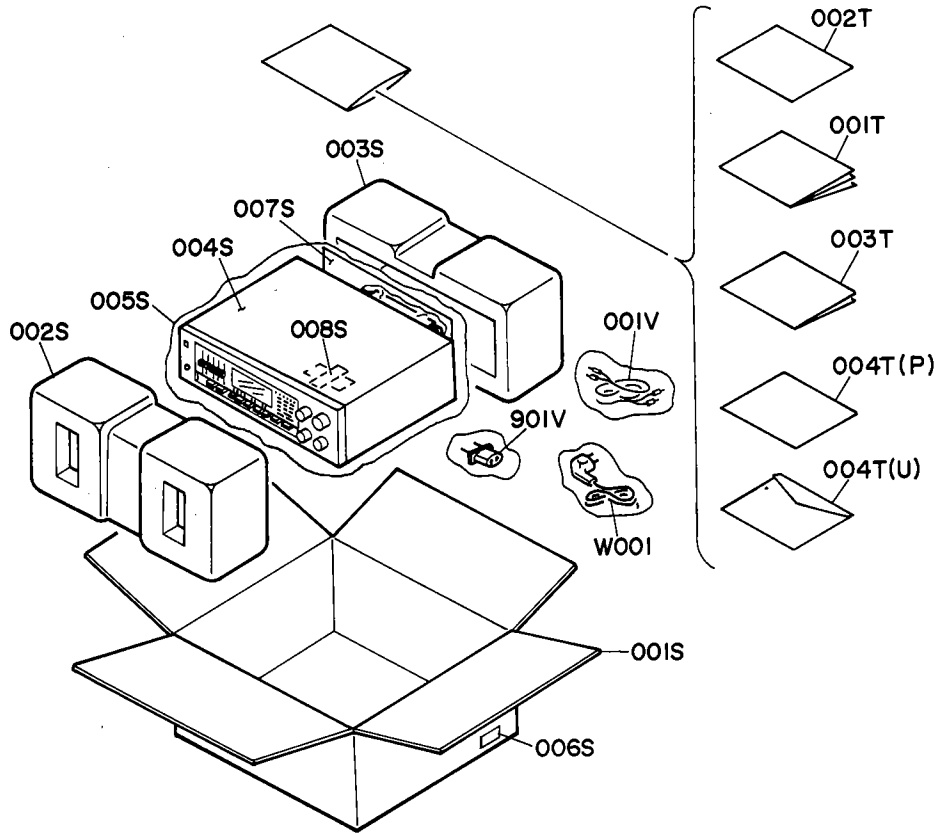

- (U): for U.S.A.
- (E): for Europe
- (P): for PX

REF. DESIG.	Q'TY			PART NO.	DESCRIPTION
	U	E	P		
001S	1			104H801010	Packing Case
001S		1		104H801020	Packing Case
001S			1	104H801050	Packing Case
002S	1	1	1	211H809010	Cushion, Front
003S	1	1	1	211H809020	Cushion, Rear
004S	1	1	1	2918107260	Sheet
005S	1	1	1	9090909030	Polyethylene Sheet
006S		2		9526019010	Serial No. Card
006S		4		9526019060	Serial No. Card
006S			3	9526019050	Serial No. Card
007S	1		1	2918107370	Sheet
008S		1		2731821010	Silicagel

REF. DESIG.	Q'TY			PART NO.	DESCRIPTION
	U	E	P		
001T	1			103H851010	Instructions
001T		1	1	103H851310	Instructions
002T	1			104H851020	Instructions, Spec
002T		1	1	104H851320	Instructions, Spec
003T	1			2818854020	Guarantee Card
003T		1		104H856010	Circuit Diagram
003T			1	2818854010	Guarantee Card
004T	1			2225813010	Envelope
004T			1	9650000010	S. Station Card
001V	1	1	1	ZA02000070	EXT. Antenna
901V		1		YJ04000240	Jack, AC Adaptor
Δ W001			1	ZC01805030	A.C. Power Cord

8.7 ELECTRICAL PARTS LIST

- (U): for U.S.A.
- (E): for Europe
- (P): for PX

REF. DESIG.	Q'TY			PART NO.	DESCRIPTION
	U	E	P		
P100	1	1	1	YK103H1710	P100-TUNER/PHONO AMP. CIRCUIT BOARD P.W. Board, Tuner/Phono Amp.
	1	1	1	ZZ104H1710	P.W. Board Assembly
		1		ZZ104H8710	P.W. Board Assembly
P100-CAPACITORS					
CA02	1	1	1	CT12000090	Trimming 20pF
CA03	1	1	1	DK17103300	Ceramic 0.01μF ±20%
CA04	1	1	1	DD10020370	Ceramic 2pF ±0.25pF
CA05	1	1	1	DD15391370	Ceramic 390pF ±5%
CA06	1	1	1	DK18403320	Ceramic 0.04μF +80%—20%
CA07	1	1	1	DK18403320	Ceramic 0.04μF +80%—20%
CA08	1	1	1	DK18102300	Ceramic 1000pF
CA09	1	1	1	DK17103300	Ceramic 0.01μF ±20%
CA10	1	1	1	DK18403320	Ceramic 0.04μF +80%—20%
CA11	1	1	1	DK18223310	Ceramic 0.022μF +80%—20%
CA12	1	1	1	DD15470370	Ceramic 47pF ±5%
CA13	1	1	1	DK18223310	Ceramic 0.022μF +80%—20%
CA14	1	1	1	DK18223310	Ceramic 0.022μF +80%—20%
CA15	1	1	1	DK18102300	Ceramic 1000pF
CA16	1	1	1	CT12000090	Trimming 20pF
CA17	1	1	1	DD10050370	Ceramic 5pF ±0.5pF
CA18	1	1	1	DF55431090	Film 430pF ±5%
CA19	1	1	1	DK18223320	Ceramic 0.022μF +80%—20%
CA20	1	1	1	EA10602530	Elect 10μF 50V
CA21	1	1	1	EA10602530	Elect 10μF 50V
CA22	1	1	1	DK18403320	Ceramic 0.04μF +80%—20%
CA23	1	1	1	EA47405030	Elect 0.47μF 50V
CA24	1	1	1	EA10701630	Elect 100μF 16V
CA25	1	1	1	DK17103300	Ceramic 0.01μF ±20%
CA26	1	1	1	DF16273300	Film 0.027μF ±10%
CA27	1	1	1	DF17682300	Film 6800pF ±20%
CA28	1	1	1	DF17403300	Film 0.04μF ±20%
CA29	1	1	1	EA10602530	Elect 10μF 25V
CA30	1	1	1	DK17103300	Ceramic 0.01μF ±20%
CV01	1	1	1	DK17103300	Ceramic 0.01μF ±20%
CV02	1	1	1	DK17103300	Ceramic 0.01μF ±20%
C101	1	1	1	CT10600090	Trimming 6pF
C103	1	1	1	DD15470370	Ceramic 47pF ±5%
C104	1	1	1	DK17103300	Ceramic 0.01μF ±20%
C105	1	1	1	CT10600090	Trimming 6pF
C106	1	1	1	DD10030300	Ceramic 3pF ±0.25pF
C107	1	1	1	CT10600090	Trimming 6pF
C108	1	1	1	DD10040300	Ceramic 4pF ±0.25pF
C109	1	1	1	DD10030370	Ceramic 3pF ±0.25pF
C110	1	1	1	DD11100370	Ceramic 10pF ±0.5pF
C111	1	1	1	DK16331300	Ceramic 330pF ±10%
C112	1	1	1	DK17103300	Ceramic 0.01μF ±20%
C113	1	1	1	DK17103300	Ceramic 0.01μF ±20%
C114	1	1	1	DK17103300	Ceramic 0.01μF ±20%
C115	1	1	1	DK17103300	Ceramic 0.01μF ±20%
C116	1	1	1	DK17103300	Ceramic 0.01μF ±20%
C118	1	1	1	DK17103300	Ceramic 0.01μF ±20%
C119	1	1	1	DK17103300	Ceramic 0.01μF ±20%
C120	1	1	1	DK17103300	Ceramic 0.01μF ±20%
C121	1	1	1	EA47405030	Elect 0.47μF 50V

REF. DESIG.	Q'TY			PART NO.	DESCRIPTION
	U	E	P		
C122	1	1	1	DK17103300	Ceramic 0.01μF ±20%
C123	1	1	1	DK17103300	Ceramic 0.01μF ±20%
C124	1	1	1	DK18403320	Ceramic 0.04μF +80%—20%
C125	1	1	1	DK18403320	Ceramic 0.04μF +80%—20%
C126	1	1	1	DK16182300	Ceramic 1800pF ±10%
C127	1	1	1	DD15330360	Ceramic 33pF ±5%
C128	1	1	1	EA47505030	Elect 4.7μF 50V
C129	1	1	1	EA47405030	Elect 0.47μF 50V
C130	1	1	1	DD11100370	Ceramic 10pF ±0.5pF
C131	1	1	1	DF16683300	Film 0.068μF ±10%
C132	1	1	1	DF17403300	Film 0.04μF ±20%
C133	1	1	1	DF16104300	Film 0.01μF ±10%
C134	1	1	1	EA10701030	Elect 100μF 10V
C135	1	1	1	EA10602530	Elect 10μF 25V
C136	1	1	1	EA22601630	Elect 22μF 16V
C137	1	1	1	EA10701630	Elect 100μF 16V
C138	1	1	1	DK16331300	Ceramic 330pF ±10%
C139	1	1	1	DK17103300	Ceramic 0.01μF ±20%
C141	1	1	1	DD10020300	Ceramic 2pF ±0.25pF
C142	1	1	1	CT10600090	Trimming 6pF
C143	1	1	1	DD10030300	Ceramic 3pF ±0.25pF
C144	1	1	1	DD10010370	Ceramic 1pF ±0.25pF
C145	1	1	1	DD11100300	Ceramic 10pF ±0.5pF
C146	1	1	1	DD15300300	Ceramic 30pF ±5%
C147	1	1	1	DD15150300	Ceramic 15pF ±5%
C148	1	1	1	DK17103300	Ceramic 0.01μF ±20%
C149	1	1	1	DK17103300	Ceramic 0.01μF ±20%
C150	1	1	1	EA10505030	Elect 1μF 50V
C151	1	1	1	EA10701630	Elect 100μF 16V
C152	1	1	1	DK17103300	Ceramic 0.01μF ±20%
C155	1	1	1	DK17103300	Ceramic 0.01μF ±20%
C153	1	1	1	DK17103300	Ceramic 0.01μF ±20%
C301	1	1	1	DF15473300	Film 0.047μF ±5%
C302	1	1	1	DF55511090	Film 510pF ±5%
C303	1	1	1	EQ10505030	Elect 1μF 50V
C304	1	1	1	EA47505030	Elect 4.7μF 50V
C305	1	1	1	DF55821090	Film 820pF ±5%
C306	1	1	1	EQ10505030	Elect 1μF 50V
C307	1	1	1	EA10505030	Elect 1μF 50V
C308	1	1	1	EA22701630	Elect 220μF 16V
C309	1	1	1	EA47505030	Elect 4.7μF 50V
C310	1	1	1	EA10505030	Elect 1μF 50V
C311	1	1	1	EA10505030	Elect 1μF 50V
C312	1	1	1	DF15332300	Film 3300pF ±5%
C312	1	1	1	DF15222300	Film 2200pF ±5%
C313	1	1	1	DF15332300	Film 3300pF ±5%
C313	1	1	1	DF15222300	Film 2200pF ±5%
C314	1	1	1	EA10405030	Elect 0.1μF 50V
C315	1	1	1	EA10405030	Elect 0.1μF 50V
C316	1	1	1	DD16101300	Ceramic 100pF ±10%
C317	1	1	1	DD16101300	Ceramic 100pF ±10%
C318	1	1	1	EA47505030	Elect 4.7μF 50V
C319	1	1	1	EA47505030	Elect 4.7μF 50V
C320	1	1	1	EA10701630	Elect 100μF 16V
C401	1	1	1	EA33505030	Elect 3.3μF 50V
C402	1	1	1	EA33505030	Elect 3.3μF 50V
C403	1	1	1	DK16331300	Ceramic 330pF ±10%
C404	1	1	1	DK16331300	Ceramic 330pF ±10%
C405	1	1	1	EA47601630	Elect 47μF 16V
C406	1	1	1	EA47601630	Elect 47μF 16V
C407	1	1	1	DF15332300	Film 3300pF ±5%

- (U): for U.S.A.
- (E): for Europe
- (P): for PX

REF. DESIG.	Q'TY			PART NO.	DESCRIPTION
	U	E	P		
C408	1	1	1	DF15332300	Film 3300pF ±5%
C409	1	1	1	DF15123300	Film 0.012μF ±5%
C410	1	1	1	DF15123300	Film 0.012μF ±5%
C411	1	1	1	EA47505030	Elect 4.7μF 50V
C412	1	1	1	EA47505030	Elect 4.7μF 50V
C413	1	1	1	DK16101300	Ceramic 100pF ±10%
C414	1	1	1	DK16101300	Ceramic 100pF ±10%
C415	1	1	1	EA10702530	Elect 100μF 25V
C416	1	1	1	EA10702530	Elect 100μF 25V
P100-RESISTORS (All Resistors are ±5% and ¼W)					
RA01	1	1	1	GD05105140	1MΩ
RA02	1	1	1	GD05102140	1KΩ
RA03	1	1	1	GD05153140	15KΩ
RA04	1	1	1	GD05152140	1.5KΩ
RA05	1	1	1	GD05101140	100Ω
RA06	1	1	1	GD05222140	2.2KΩ
RA07	1	1	1	GD05471140	470Ω
RA08	1	1	1	GD05104140	100KΩ
RA09	1	1	1	GD05222140	2.2KΩ
RA10	1	1	1	GD05103140	10KΩ
RA11	1	1	1	RA01030260	10KΩ(B), Trimming
RA12	1	1	1	GD05820140	820Ω
RA13	1	1	1	GD05103140	10KΩ
RA14	1	1	1	GD05101140	100Ω
RA15	1	1	1	GD05102140	1KΩ
RA16	1	1	1	GD05153140	15KΩ
RA18	1	1	1	GG05101140	100Ω
RA19	1	1	1	GD05333140	33KΩ
RA20	1	1	1	GD05221140	220Ω
RA21	1	1	1	GD05225140	2.2MΩ
RA22	1	1	1	GD05152140	1.5KΩ
RC01	1	1	1	GD05103140	10KΩ
RC02	1	1	1	GD05223140	22KΩ
RC03	1	1	1	GD05104140	100KΩ
RC04	1	1	1	GD05104140	100KΩ
RC05	1	1	1	GD05103140	10KΩ
RC06	1	1	1	GD05223140	22KΩ
RC07	1	1	1	GD05104140	100KΩ
RC08	1	1	1	GD05104140	100KΩ
RC09	1	1	1	GD05103140	10KΩ
RC10	1	1	1	GD05223140	22KΩ
RC11	1	1	1	GD05104140	100KΩ
RC12	1	1	1	GD05103140	10KΩ
RC13	1	1	1	GD05103140	10KΩ
RC14	1	1	1	GD05223140	22KΩ
RC15	1	1	1	GD05104140	100KΩ
RC16	1	1	1	GD05103140	10KΩ
RC17	1	1	1	GG05122120	1.2KΩ ¼W
RC18	1	1	1	GG05122120	1.2KΩ ¼W
R101	1	1	1	GD05104140	100KΩ
R102	1	1	1	GD05104140	100KΩ
R103	1	1	1	GD05104140	100KΩ
R104	1	1	1	GD05101140	100Ω
R105	1	1	1	GD05104140	100KΩ
R106	1	1	1	GD05104140	100KΩ
R107	1	1	1	GD05472140	4.7KΩ
R108	1	1	1	GD05223140	22KΩ
R109	1	1	1	GD05332140	3.3KΩ
R110	1	1	1	GD05273140	27KΩ

REF. DESIG.	Q'TY			PART NO.	DESCRIPTION
	U	E	P		
R111	1	1	1	GD05331140	330Ω
R112	1	1	1	GD05153140	15KΩ
R113	1	1	1	GD05272140	2.7KΩ
R114	1	1	1	GD05102140	1KΩ
R115	1	1	1	GD05331140	330Ω
R116	1	1	1	GD05223140	22KΩ
R117	1	1	1	GD05101140	100Ω
R118	1	1	1	GD05101140	100Ω
R119	1	1	1	GG05470140	47Ω
R120	1	1	1	GD05183140	18KΩ
R121	1	1	1	GD05332140	3.3KΩ
R122	1	1	1	RA01030260	10KΩ(B), Trimming
R123	1	1	1	GD05124140	120KΩ
R124	1	1	1	GD05183140	18KΩ
R125	1	1	1	GD05332140	3.3KΩ
R126	1	1	1	GD05331140	330Ω
R127	1	1	1	GD05104140	100KΩ
R128	1	1	1	GD05184140	180KΩ
R130	1	1	1	GD05821140	820Ω
R131	1	1	1	GD05273140	27KΩ
R132	1	1	1	GD05104140	100KΩ
R133	1	1	1	GD05122140	1.2KΩ
R134	1	1	1	GD05272140	2.7KΩ
R135	1	1	1	GD05272140	2.7KΩ
R136	1	1	1	RA01040110	100KΩ(B), Trimming
R137	1	1	1	GD05562140	5.6KΩ
R138	1	1	1	GD05104140	100KΩ
R139	1	1	1	GD05273140	27KΩ
R140	1	1	1	GD05102140	1KΩ
R141	1	1	1	GD05563140	56KΩ
R142	1	1	1	GD05101140	100Ω
R143	1	1	1	GD05124140	120KΩ
R144	1	1	1	GG05101140	100Ω
R145	1	1	1	GD05102140	1KΩ
R146	1	1	1	GD05331140	330Ω
R147	1	1	1	GD05104140	100KΩ
R148	1	1	1	GD05821140	820Ω
R149	1	1	1	GD05104140	100KΩ
R150	1	1	1	GD05103140	10KΩ
R151	1	1	1	GD05103140	10KΩ
R152	1	1	1	GD05222140	2.2KΩ
R153	1	1	1	GD05101140	100Ω
R154	1	1	1	GD05222140	2.2KΩ
R155	1	1	1	GD05223140	22KΩ
R156	1	1	1	GD05103140	10KΩ
R157	1	1	1	GD05104140	100KΩ
R158	1	1	1	GD05153140	15KΩ
R159	1	1	1	GD05183140	18KΩ
R161	1	1	1	GD05103140	10KΩ
R162	1	1	1	GD05104140	100KΩ
R163	1	1	1	GD05153140	15KΩ
R164	1	1	1	GD05153140	15KΩ
R165	1	1	1	GD05153140	15KΩ
R167	1	1	1	GD05103140	10KΩ
R168	1	1	1	GD05334140	330KΩ
R169	1	1	1	GD05333140	33KΩ
R170	1	1	1	GD05222140	2.2KΩ
R171	1	1	1	GD05103140	10KΩ
R172	1	1	1	GD05103140	10KΩ
R173	1	1	1	GD05564140	560KΩ

- (U): for U.S.A.
- (E): for Europe
- (P): for PX

REF. DESIG.	Q'TY			PART NO.	DESCRIPTION
	U	E	P		
R301	1	1	1	GD05473140	47KΩ
R302	1	1	1	GD05224140	220KΩ
R303	1	1	1	GD05153140	15KΩ
R304	1	1	1	RA05020160	5KΩ(B), Trimming
R305	1	1	1	GD05821140	820Ω
R306	1	1	1	GD05102140	1KΩ
R307	1	1	1	RA02020180	2KΩ(B), Trimming
R308	1	1	1	GD05472140	4.7KΩ
R309	1	1	1	GD05472140	4.7KΩ
R310	1	1	1	GD05103140	10KΩ
R311	1	1	1	GD05473140	47KΩ
R312	1	1	1	GG05101140	100Ω
R313	1	1	1	GD05154140	150KΩ
R314	1	1	1	GD05472140	4.7KΩ
R315	1	1	1	GD05472140	4.7KΩ
R316	1	1	1	GD05273140	27KΩ
R317	1	1	1	GD05273140	27KΩ
R318	1	1	1	GD05154140	150KΩ
R319	1	1	1	GD05154140	150KΩ
R320	1	1	1	GD05471140	470Ω
R321	1	1	1	GD05471140	470Ω
R322	1	1	1	RA05030090	50KΩ(B), Trimming
R323	1	1	1	GD05102140	1KΩ
R324	1	1	1	GD05822140	8.2KΩ
R325	1	1	1	GD05822140	8.2KΩ
R326	1	1	1	GD05155140	1.5MΩ
R327	1	1	1	GD05155140	1.5MΩ
R328	1	1	1	GD05392140	3.9KΩ
R329	1	1	1	GD05392140	3.9KΩ
R330	1	1	1	GD05392140	3.9KΩ
R331	1	1	1	GD05392140	3.9KΩ
R332	1	1	1	GD05104140	100KΩ
R333	1	1	1	GD05104140	100KΩ
R334	1	1	1	GG05470140	47Ω
R335	1	1	1	GD05154140	150KΩ
R336	1	1	1	GD05333140	33KΩ
R338	1	1	1	GD05184140	180KΩ
R339	1	1	1	GD05184140	180KΩ
R401	1	1	1	GD05104140	100KΩ
R402	1	1	1	GD05104140	100KΩ
R403	1	1	1	GD05222140	2.2KΩ
R404	1	1	1	GD05222140	2.2KΩ
R405	1	1	1	GD05104140	100KΩ
R406	1	1	1	GD05104140	100KΩ
R407	1	1	1	GD05471140	470Ω
R408	1	1	1	GD05471140	470Ω
R409	1	1	1	GD05223140	22KΩ
R410	1	1	1	GD05223140	22KΩ
R411	1	1	1	GD05274140	270KΩ
R412	1	1	1	GD05274140	270KΩ
R413	1	1	1	GD05224140	220KΩ
R414	1	1	1	GD05224140	220KΩ
R415	1	1	1	GD05221140	220Ω
R416	1	1	1	GD05221140	220Ω
R417	1	1	1	GG05101140	100Ω
R418	1	1	1	GG05101140	100Ω

REF. DESIG.	Q'TY			PART NO.	DESCRIPTION
	U	E	P		
P100-SEMICONDUCTORS					
QA01	1	1	1	HC10058030	IC LA1245
QA02	1	1	1	HF200551D0	F.E.T. 2SK55(D)
QA03	1	1	1	HD40002420	Varicap KV-1226
QA05	1	1	1	HV00006120	Varistor MV-203
QC01	1	1	1	HT309452A0	Transistor 2SC945(Q or R)
QC02	1	1	1	HT107332A0	Transistor 2SA733(Q or R)
QC03	1	1	1	HT309452A0	Transistor 2SC945(Q or R)
QC04	1	1	1	HT107332A0	Transistor 2SA733(Q or R)
QC05	1	1	1	HT309452A0	Transistor 2SC945(Q or R)
QC06	1	1	1	HT309452A0	Transistor 2SC945(Q or R)
QC07	1	1	1	HT309452A0	Transistor 2SC945(Q or R)
QC08	1	1	1	HT309452A0	Transistor 2SC945(Q or R)
QC09	1	1	1	HD20015030	Diode DS135D
QC10	1	1	1	HD20015030	Diode DS135D
Q101	1	1	1	HF400451B0	F.E.T. 3SK45(B)
Q102	1	1	1	HF200551D0	F.E.T. 2SK55(D)
Q103	1	1	1	HT308291D0	Transistor 2SC829(D)
Q104	1	1	1	HT308291C0	Transistor 2SC829(C)
Q105	1	1	1	HT310471C0	Transistor 2SC1047(C)
Q106	1	1	1	HT308291C0	Transistor 2SC829(C)
Q107	1	1	1	HT309452A0	Transistor 2SC945(Q or R)
Q108	1	1	1	HT309452A0	Transistor 2SC945(Q or R)
Q109	1	1	1	HD40004010	Varicap 1SV55
Q110	1	1	1	HD40004010	Varicap 1SV55
Q111	1	1	1	HD40004010	Varicap 1SV55
Q112	1	1	1	HD40004010	Varicap 1SV55
Q113	1	1	1	HC10028030	IC LA1231N
Q114	1	1	1	HT309452C0	Transistor 2SC945(K or P)
Q115	1	1	1	HT309452A0	Transistor 2SC945(Q or R)
Q116	1	1	1	HD20001210	Diode 1S2473
Q117	1	1	1	HD20001210	Diode 1S2473
Q118	1	1	1	HD20001210	Diode 1S2473
Q119	1	1	1	HD20001210	Diode 1S2473
Q120	1	1	1	HD20001210	Diode 1S2473
Q121	1	1	1	HD20001210	Diode 1S2473
Q122	1	1	1	HD20001210	Diode 1S2473
Q123	1	1	1	HD20001210	Diode 1S2473
Q124	1	1	1	HD20001210	Diode 1S2473
Q125	1	1	1	HD20001210	Diode 1S2473
Q126	1	1	1	HD20001210	Diode 1S2473
Q127	1	1	1	HV00006120	Varistor MV-203
Q128	1	1	1	HT309452A0	Transistor 2SC945(Q or R)
Q129	1	1	1	HT309452A0	Transistor 2SC945(Q or R)
Q130	1	1	1	HD30029090	Zener WZ090
Q131	1	1	1	HT309452A0	Transistor 2SC945(Q or R)
Q132	1	1	1	HD20001210	Diode 1S2473
Q133	1	1	1	HD20001210	Diode 1S2473
Q301	1	1	1	HC10001420	IC KB4437
Q302	1	1	1	HT309452A0	Transistor 2SC945(Q or R)
Q303	1	1	1	HT309452A0	Transistor 2SC945(Q or R)
Q304	1	1	1	HT326342B0	Transistor 2SC2634(S or T)
Q305	1	1	1	HT326342B0	Transistor 2SC2634(S or T)
Q306	1	1	1	HT111272B0	Transistor 2SA1127(S or T)
Q307	1	1	1	HT111272B0	Transistor 2SA1127(S or T)
Q401	1	1	1	HC10013370	IC TL4558PB

- (U): for U.S.A.
- (E): for Europe
- (P): for PX

REF. DESIG.	Q'TY			PART NO.	DESCRIPTION
	U	E	P		
P100-MISCELLANEOUS					
FA01	1	1	1	FG450302B0	Ceramic Filter SFZ450B-3
FA02	1	1	1	FF10045270	Ceramic Filter BFU450C
F101	1	1	1	FF11070530	Ceramic Filter 10.7MHz MD-1
F102	1	1	1	FF11070530	Ceramic Filter 10.7MHz MD-1
F102	1	1	1	FF11070570	Ceramic Filter 10.7MHz MS3G
F103	1	1	1	FF11070530	Ceramic Filter 10.7MHz MD-1
F103	1	1	1	FF11070570	Ceramic Filter 10.7MHz MS3G
JV01	1			YT02040350	Terminal, Phono/Aux Input
JV01	1	1	1	YT02040340	Terminal, Phono/Aux Input
J101	1	1	1	YJ01050010	Terminal, Antenna
J102	1	1	1	YJ06002430	Jack, (3P)
J103	1	1	1	YJ06002460	Jack, (7P)
J104	1	1	1	YJ06002270	Jack, (8P)
LA01	1	1	1	LA10015010	Antenna Coil, AM
LA02	1	1	1	LO10013170	OSC Coil, AM
LA03	1	1	1	LI10010730	I.F.T. Coil, AM IF
LA05	1	1	1	LC11540040	Choke Coil, 150μH
LC01	1	1	1	LY20240020	Relay, 2V 23mA
LC02	1	1	1	LY20240020	Relay, 2V 23mA
L101	1	1	1	LA12026190	Antenna Coil, FM
L102	1	1	1	LA12026200	Antenna Coil, FM RF
L103	1	1	1	LA12026210	Antenna Coil, FM RF
L104	1	1	1	LO12046030	OSC Coil, FM
L105	1	1	1	LC17510010	Choke Coil, 0.75μH
L106	1	1	1	LI10018110	I.F.T. Coil, FM IF
L107	1	1	1	LC13320050	Choke Coil, 3.3μH
L108	1	1	1	LI14030020	I.F.T. Coil, FM DET
L109	1	1	1	LS35040010	M.P.X. Coil
L110	1	1	1	LS10290190	M.P.X. Coil
L111	1	1	1	LC11050060	Choke Coil, 1mH
L301	1	1	1	LS20010020	M.P.X. Coil, L.P.F. (38KHz)
W101	1	1	1	YU06120260	Jumper Lead, (6P)
W102	1	1	1	YU04120260	Jumper Lead, (4P)
P500-CONTROLLER CIRCUIT BOARD					
P500	1	1	1	YK103H2730	P.W. Board, Controller
	1	1	1	ZZ103H2730	P.W. Board Assembly
P500-CAPACITORS					
C501	1	1	1	EA10701630	Elect 100μF 16V
C502	1	1	1	EA47405030	Elect 0.47μF 50V
C503	1	1	1	EA10505030	Elect 1μF 50V
P500-RESISTORS					
(All Resistors are ±5% and 1/8W)					
G501	1	1	1	BW10104020	100KΩ x 8 1/8W Compo.
G502	1	1	1	BW10104010	100KΩ x 6 1/8W Compo.
G503	1	1	1	BW10104010	100KΩ x 6 1/8W Compo.
G504	1	1	1	BW10473010	47KΩ x 5 1/8W Compo.
G505	1	1	1	BW10473010	47KΩ x 5 1/8W Compo.

REF. DESIG.	Q'TY			PART NO.	DESCRIPTION
	U	E	P		
R501	1	1	1	GD05104140	100KΩ
R502	1	1	1	GD05104140	100KΩ
R503	1	1	1	GD05104140	100KΩ
R504	1	1	1	GD05104140	100KΩ
R505	1	1	1	GD05104140	100KΩ
R506	1	1	1	GD05104140	100KΩ
R507	1	1	1	GD05104140	100KΩ
R508	1	1	1	GD05104140	100KΩ
R509	1	1	1	GD05104140	100KΩ
R510	1	1	1	GD05104140	100KΩ
R511	1	1	1	GD05104140	100KΩ
R512	1	1	1	GD05104140	100KΩ
R513	1	1	1	GD05104140	100KΩ
R514	1	1	1	GD05104140	100KΩ
R515	1	1	1	GD05103140	10KΩ
R516	1	1	1	GD05103140	10KΩ
R517	1	1	1	GD05103140	10KΩ
R518	1	1	1	GD05103140	10KΩ
R519	1	1	1	GD05103140	10KΩ
R520	1	1	1	GD05103140	10KΩ
R521	1	1	1	GD05103140	10KΩ
R522	1	1	1	GD05103140	10KΩ
R523	1	1	1	GD05103140	10KΩ
R524	1	1	1	GD05103140	10KΩ
R525	1	1	1	GD05473140	47KΩ
R526	1	1	1	GD05103140	10KΩ
R527	1	1	1	GD05473140	47KΩ
R528	1	1	1	GD05103140	10KΩ
R529	1	1	1	GD05473140	47KΩ
R530	1	1	1	GD05473140	47KΩ
R531	1	1	1	GD05103140	10KΩ
R532	1	1	1	GD05103140	10KΩ
R533	1	1	1	GD05104140	100KΩ
P500-SEMICONDUCTORS					
Q501	1	1	1	HC10027020	IC MN1455LF
Q502	1	1	1	HT107332A0	Transistor 2SA733(O or R)
Q503	1	1	1	HT107332A0	Transistor 2SA733(O or R)
Q504	1	1	1	HT107332A0	Transistor 2SA733(O or R)
Q505	1	1	1	HT107332A0	Transistor 2SA733(O or R)
Q506	1	1	1	HT107332A0	Transistor 2SA733(O or R)
Q507	1	1	1	HT107332A0	Transistor 2SA733(O or R)
Q508	1	1	1	HT107332A0	Transistor 2SA733(O or R)
Q509	1	1	1	HT107332A0	Transistor 2SA733(O or R)
Q510	1	1	1	HT107332A0	Transistor 2SA733(O or R)
Q511	1	1	1	HT107332A0	Transistor 2SA733(O or R)
Q512	1	1	1	HT107332A0	Transistor 2SA733(O or R)
Q513	1	1	1	HT107332A0	Transistor 2SA733(O or R)
Q514	1	1	1	HT107332A0	Transistor 2SA733(O or R)
Q515	1	1	1	HT107332A0	Transistor 2SA733(O or R)
Q516	1	1	1	HT107332A0	Transistor 2SA733(O or R)
Q517	1	1	1	HT309452A0	Transistor 2SC945(O or R)
Q518	1	1	1	HT309452A0	Transistor 2SC945(O or R)
Q519	1	1	1	HT309452A0	Transistor 2SC945(O or R)
Q520	1	1	1	HT309452A0	Transistor 2SC945(O or R)
Q521	1	1	1	HT309452A0	Transistor 2SC945(O or R)
Q522	1	1	1	HT309452A0	Transistor 2SC945(O or R)
Q523	1	1	1	HT309452A0	Transistor 2SC945(O or R)
Q524	1	1	1	HT309452A0	Transistor 2SC945(O or R)
Q525	1	1	1	HT309452A0	Transistor 2SC945(O or R)

- (U): for U.S.A.
- (E): for Europe
- (P): for PX

REF. DESIG.	Q'TY			PART NO.	DESCRIPTION
	U	E	P		
Q526	1	1	1	HT309452A0	Transistor 2SC945(O or R)
Q527	1	1	1	HT309452A0	Transistor 2SC945(O or R)
Q528	1	1	1	HT309452A0	Transistor 2SC945(O or R)
Q529	1	1	1	HT309452A0	Transistor 2SC945(O or R)
Q530	1	1	1	HT309452A0	Transistor 2SC945(O or R)
Q531	1	1	1	HT309452A0	Transistor 2SC945(O or R)
Q532	1	1	1	HT309452A0	Transistor 2SC945(O or R)
Q533	1	1	1	HT309452A0	Transistor 2SC945(O or R)
Q534	1	1	1	HT309452A0	Transistor 2SC945(O or R)
Q535	1	1	1	HT309452A0	Transistor 2SC945(O or R)
Q536	1	1	1	HD20001210	Diode 1S2473
Q537	1	1	1	HD20001210	Diode 1S2473
Q538	1	1	1	HD20001210	Diode 1S2473
Q539	1	1	1	HD20001210	Diode 1S2473
Q540	1	1	1	HD20001210	Diode 1S2473
Q541	1	1	1	HD20001210	Diode 1S2473
Q542	1	1	1	HD20001210	Diode 1S2473
Q543	1	1	1	HD20001210	Diode 1S2473
Q544	1	1	1	HD20001210	Diode 1S2473
Q545	1	1	1	HD20001210	Diode 1S2473
Q546	1	1	1	HD20001210	Diode 1S2473
Q547	1	1	1	HD20001210	Diode 1S2473
Q548	1	1	1	HD20001210	Diode 1S2473
Q549	1	1	1	HD20001210	Diode 1S2473
Q550	1	1	1	HD20001210	Diode 1S2473
Q551	1	1	1	HD20001210	Diode 1S2473
Q552	1	1	1	HD20001210	Diode 1S2473
Q553	1	1	1	HD20001210	Diode 1S2473
Q554	1	1	1	HD20001210	Diode 1S2473
Q556	1	1	1	HD20001210	Diode 1S2473
Q557	1	1	1	HD20001210	Diode 1S2473
Q559	1	1	1	HD20001210	Diode 1S2473
Q560	1	1	1	HD20001210	Diode 1S2473
Q561	1	1	1	HD20001210	Diode 1S2473
Q562	1	1	1	HD20001210	Diode 1S2473
Q563	1	1	1	HD20001210	Diode 1S2473
Q564	1	1	1	HD20001210	Diode 1S2473
Q565	1	1	1	HD20001210	Diode 1S2473
Q566	1	1	1	HD20001210	Diode 1S2473
Q567	1	1	1	HD20001210	Diode 1S2473
Q568	1	1	1	HD20001210	Diode 1S2473
P500-MISCELLANEOUS					
J501	1	1	1	YJ06002270	Jack, (8P)
J502	1	1	1	YJ06002460	Jack, (7P)
J504	1	1	1	YJ06002450	Jack, (6P)
J505	1	1	1	YJ06002460	Jack, (7P)
J506	1	1	1	YJ06002430	Jack, (3P)
J507	1	1	1	YJ06002430	Jack, (3P)
W501	1	1	1	YU05200260	Jumper Lead, (5P)
W502	1	1	1	YU04180260	Jumper Lead, (4P)
W503	1	1	1	YU02220260	Jumper Lead, (2P)

REF. DESIG.	Q'TY			PART NO.	DESCRIPTION
	U	E	P		
P501-PLL/L.P.F. CIRCUIT BOARD					
P501	1	1	1	YK103H2750	P.W. Board, PLL/L.P.F.
	1	1	1	ZZ103H2750	P.W. Board Assembly
P501-CAPACITORS					
C511	1	1	1	EA47405030	Elect 0.47 μ F 50V
C512	1	1	1	DK18333310	Ceramic 0.033 μ F +80% -20%
C513	1	1	1	DF15223300	Film 0.22 μ F \pm 5%
C514	1	1	1	DD15270300	Ceramic 27pF \pm 5%
C515	1	1	1	CT12000090	Trimming 20pF
C516	1	1	1	DK18333310	Ceramic 0.033 μ F +80% -20%
C517	1	1	1	EA47405030	Elect 0.47 μ F 50V
C518	1	1	1	DF15103300	Film 0.01 μ F \pm 5%
C519	1	1	1	EQ47505010	Elect 4.7 μ F 50V
C520	1	1	1	EA10703530	Elect 100 μ F 35V
C521	1	1	1	DF15473300	Film 0.047 μ F \pm 5%
P501-RESISTORS (All Resistors are \pm 5% and $\frac{1}{4}$ W)					
G506	1	1	1	BW10473010	47K Ω x 2 1/8W Compo.
R541	1	1	1	GD05103140	10K Ω
R542	1	1	1	GD05103140	10K Ω
R544	1	1	1	GD05103140	10K Ω
R545	1	1	1	GD05103140	10K Ω
R547	1	1	1	GD05104140	100K Ω
R548	1	1	1	GD05104140	100K Ω
R549	1	1	1	GD05335140	3.3M Ω
R550	1	1	1	GG05221140	220 Ω
R551	1	1	1	GD05332140	3.3K Ω
R552	1	1	1	GD05561140	560 Ω
R553	1	1	1	GD05102140	1K Ω
R554	1	1	1	GD05561140	560 Ω
R555	1	1	1	GD05682140	6.8K Ω
P501-SEMICONDUCTORS					
Q571	1	1	1	HC10028020	IC MN6147
Q572	1	1	1	HC10040010	IC 74LS42
Q573	1	1	1	HT309452A0	Transistor 2SC945(O or R)
Q574	1	1	1	HT309452A0	Transistor 2SC945(O or R)
Q575	1	1	1	HF200301C0	F.E.T. 2SK30(Y)
Q577	1	1	1	HT309452A0	Transistor 2SC945(O or R)
Q578	1	1	1	HT309452A0	Transistor 2SC945(O or R)
Q579	1	1	1	HD20001210	Diode 1S2473
P501-MISCELLANEOUS					
J509	1	1	1	YJ06002450	Jack, (6P)
J510	1	1	1	YJ06002390	Jack, (5P)
J511	1	1	1	YJ07000770	Jack, (8P)
W504	1	1	1	YU08260260	Jumper Lead, (8P)
X501	1	1	1	XB108001L2	Crystal 4.5MHz

- (U): for U.S.A.
- (E): for Europe
- (P): for PX

REF. DESIG.	Q'TY			PART NO.	DESCRIPTION
	U	E	P		
P502	1	1	1	YK103H2710 ZZ103H2710	P502-VFL/SIGNAL LED CIRCUIT BOARD P.W. Board, VFL/Signal LED P.W. Board Assembly
P502-CAPACITORS					
C531	1	1	1	EA10505030	Elect 1 μ F 50V
C532	1	1	1	EA10602530	Elect 10 μ F 25V
C533	1	1	1	EA10602530	Elect 10 μ F 25V
C534	1	1	1	EA10701630	Elect 100 μ F 16V
C535	1	1	1	DK17103300	Ceramic 0.01 μ F \pm 20%
P502-RESISTORS (All Resistors are \pm 5% and $\frac{1}{4}$ W)					
R561	1	1	1	GD05390140	39 Ω
R562	1	1	1	GD05390140	39 Ω
R563	1	1	1	GD05391140	390 Ω
R564	1	1	1	GD05391140	390 Ω
R565	1	1	1	GD05391140	390 Ω
R566	1	1	1	GD05153140	15K Ω
R567	1	1	1	GD05333140	33K Ω
R568	1	1	1	GD05562140	5.6K Ω
R569	1	1	1	GD05103140	10K Ω
R570	1	1	1	GD05682140	6.8K Ω
R571	1	1	1	GG05680140	68 Ω
P502-SEMICONDUCTORS					
Q581	1	1	1	HC10040030	IC LB1416
Q582	1	1	1	HI10006320	L.E.D. GL-9NG9
Q583	1	1	1	HI10007320	L.E.D. GL-9PR9
Q584	1	1	1	HI10007320	L.E.D. GL-9PR9
Q585	1	1	1	HI10007320	L.E.D. GL-9PR9
Q586	1	1	1	HI10007320	L.E.D. GL-9PR9
Q587	1	1	1	HI10007320	L.E.D. GL-9PR9
Q588	1	1	1	HI10006320	L.E.D. GL-9NG9
Q589	1	1	1	HI10006320	L.E.D. GL-9NG9
P502-MISCELLANEOUS					
J512	1	1	1	YJ06002430	Jack, (3P)
V501	1	1	1	HQ30701410	Display Unit 8-MT-01
W505	1	1	1	YU05300260	Jumper Lead, (5P)
W506	1	1	1	YU02260260	Jumper Lead, (2P)
W507	1	1	1	YU02280260	Jumper Lead, (2P)
P503-CONTROLLER/FIP JUMPER CIRCUIT BOARD					
P503	1	1	1	YK103H2740 ZZ103H2740	P.W. Board, Controller/ Fip Jumper P.W. Board Assembly
R581	1	1	1	GD05104140	Resistor 100K Ω \pm 5% $\frac{1}{4}$ W
Q591	1	1	1	HD20001210	Diode 1S2473
Q593	1	1	1	HD20001210	Diode 1S2473
Q594	1	1	1	HD20001210	Diode 1S2473
P504-CONTROLLER/PLL JUMPER CIRCUIT BOARD					
P504	1	1	1	YK103H2720	P.W. Board, Controller/ PLL Jumper

REF. DESIG.	Q'TY			PART NO.	DESCRIPTION
	U	E	P		
P700	1	1	1	YK103H3410 ZZ104H3410	P700-MAIN AMP. CIRCUIT BOARD P.W. Board, Main Amp. P.W. Board Assembly
P700-CAPACITORS					
CN13	1	1	1	EA22701030	Elect 220 μ F 10V
CN14	1	1	1	EA33601030	Elect 33 μ F 10V
CN16	1	1	1	EA47605030	Elect 47 μ F 50V
CN17	1	1	1	EA47601030	Elect 47 μ F 10V
C701	1	1	1	DK16221300	Ceramic 220pF \pm 10%
C702	1	1	1	DK16221300	Ceramic 220pF \pm 10%
C703	1	1	1	EA10505030	Elect 1 μ F 50V
C704	1	1	1	EA10505030	Elect 1 μ F 50V
C705	1	1	1	EA47505030	Elect 4.7 μ F 50V
C706	1	1	1	EA47505030	Elect 4.7 μ F 50V
C707	1	1	1	DK16561300	Ceramic 560pF \pm 10%
C708	1	1	1	DK16561300	Ceramic 560pF \pm 10%
C709	1	1	1	DD15200360	Ceramic 20pF \pm 5%
C710	1	1	1	DD15200360	Ceramic 20pF \pm 5%
C711	1	1	1	DD15270370	Ceramic 27pF \pm 5%
C712	1	1	1	DD15270370	Ceramic 27pF \pm 5%
C715	1	1	1	DD11070370	Ceramic 7pF \pm 0.5pF
C716	1	1	1	DD11070370	Ceramic 7pF \pm 0.5pF
C717	1	1	1	EA47606330	Elect 47 μ F 63V
C718	1	1	1	EA47606330	Elect 47 μ F 63V
P700-RESISTORS (All Resistors are \pm 5% and $\frac{1}{4}$ W)					
RN21	1	1	1	GD05224140	220K Ω
RN22	1	1	1	GD05223140	22K Ω
RN23	1	1	1	GD05223140	22K Ω
RN24	1	1	1	GD05273140	27K Ω
RN25	1	1	1	GD05682140	6.8K Ω
RN26	1	1	1	GG05101140	100 Ω
RN29	1	1	1	GD05103140	10K Ω
RN30	1	1	1	GD05563140	56K Ω
R701	1	1	1	GD05474140	470K Ω
R702	1	1	1	GD05474140	470K Ω
R703	1	1	1	GD05221140	220 Ω
R704	1	1	1	GD05221140	220 Ω
R705	1	1	1	GD05273140	27K Ω
R706	1	1	1	GD05273140	27K Ω
R707	1	1	1	RA02230020	22K Ω (B), Trimming
R708	1	1	1	RA02230020	22K Ω (B), Trimming
R709	1	1	1	GD05272140	2.7K Ω
R710	1	1	1	GD05272140	2.7K Ω
R711	1	1	1	GD05683140	68K Ω
R712	1	1	1	GD05683140	68K Ω
R713	1	1	1	GD05471140	470 Ω
R714	1	1	1	GD05471140	470 Ω
R715	1	1	1	GD05122140	1.2K Ω
R716	1	1	1	GD05122140	1.2K Ω
R717	1	1	1	RA01020360	1K Ω (B), Trimming
R718	1	1	1	RA01020360	1K Ω (B), Trimming
R719	1	1	1	GD05272140	2.7K Ω
R720	1	1	1	GD05272140	2.7K Ω
R721	1	1	1	GG05101140	100 Ω
R722	1	1	1	GG05101140	100 Ω
R739	1	1	1	GD05100140	10 Ω
R740	1	1	1	GD05100140	10 Ω
R741	1	1	1	GD05333140	33K Ω
R742	1	1	1	GD05333140	33K Ω

- (U): for U.S.A.
- (E): for Europe
- (P): for PX

REF. DESIG.	QTY			PART NO.	DESCRIPTION
	U	E	P		
QN19	1	1	1	HC10046060	P700-SEMICONDUCTORS IC μ PC1237H Transistor 2SA733(Q or R)
QN20	1	1	1	HT107332A0	
Q715	1	1	1	HC10032030	IC STK3082
J703	1	1	1	YP06001040	P700-MISCELLANEOUS Plug, (3P) Plug, (3P)
J704	1	1	1	YP06000570	
P701	1	1	1	YK103H3420	P701-MAIN AMP. CIRCUIT BOARD P.W. Board, Main Amp. P.W. Board Assembly
	1	1	1	ZZ104H3420	
CN01	1	1	1	DF15103350	P701-CAPACITORS Film 0.01 μ F \pm 5% Film 0.01 μ F \pm 5% Film 0.01 μ F \pm 5% Film 0.01 μ F \pm 5%
CN02	1	1	1	DF15103350	
CN03	1	1	1	DF15103350	
CN04	1	1	1	DF15103350	
C713	1	1	1	DF17473520	Film 0.047 μ F \pm 20%
C714	1	1	1	DF17473520	
C719	1	1	1	EA10706330	Elect 100 μ F 63V
C720	1	1	1	EA10706330	
C721	1	1	1	EA10706330	Elect 100 μ F 63V
C722	1	1	1	EA10706330	
C723	1	1	1	DK16331300	Ceramic 330pF \pm 10%
C724	1	1	1	DK16331300	
RN01	1	1	1	GG05332140	P701-RESISTORS (All Resistors are \pm 5% and $\frac{1}{4}$ W) 3.3K Ω 3.3K Ω 15K Ω 15K Ω 3.3K Ω 3.3K Ω 100 Ω 100 Ω 100 Ω 100 Ω 150 Ω 150 Ω 150 Ω 150 Ω 68K Ω 68K Ω 10K Ω 10K Ω 10 Ω 10 Ω 10 Ω 10 Ω 0.33 Ω \pm 10% 5W 0.33 Ω \pm 10% 5W 0.33 Ω \pm 10% 5W 0.33 Ω \pm 10% 5W 270 Ω 1W 270 Ω 1W 10 Ω 3W 10 Ω 3W 2.2 Ω \pm 10% $\frac{1}{2}$ W 2.2 Ω \pm 10% $\frac{1}{2}$ W 330 Ω 1W 330 Ω 1W
RN02	1	1	1	GG05332140	
RN03	1	1	1	GD05153140	
RN04	1	1	1	GD05153140	
RN05	1	1	1	GG05332140	
RN06	1	1	1	GG05332140	
RN11	1	1	1	GG05101140	
RN12	1	1	1	GG05101140	
RN13	1	1	1	GG05101140	
RN14	1	1	1	GG05101140	
RN15	1	1	1	GG05151140	
RN16	1	1	1	GG05151140	
RN17	1	1	1	GG05151140	
RN18	1	1	1	GG05151140	
RN19	1	1	1	GD05683140	
RN20	1	1	1	GD05683140	
RN31	1	1	1	GD05103140	
RN32	1	1	1	GD05103140	
R723	1	1	1	GG05100140	10 Ω 10 Ω 10 Ω 10 Ω 0.33 Ω \pm 10% 5W 0.33 Ω \pm 10% 5W 0.33 Ω \pm 10% 5W 0.33 Ω \pm 10% 5W 270 Ω 1W 270 Ω 1W 10 Ω 3W 10 Ω 3W 2.2 Ω \pm 10% $\frac{1}{2}$ W 2.2 Ω \pm 10% $\frac{1}{2}$ W 330 Ω 1W 330 Ω 1W
R724	1	1	1	GG05100140	
R725	1	1	1	GG05100140	
R726	1	1	1	GG05100140	
R727	1	1	1	GO10332050	
R728	1	1	1	GO10332050	
R729	1	1	1	GO10332050	
R730	1	1	1	GO10332050	
R731	1	1	1	GA05271010	
R732	1	1	1	GA05271010	
R733	1	1	1	GA05100030	
R734	1	1	1	GA05100030	
R735	1	1	1	RC10022120	
R736	1	1	1	RC10022120	
R737	1	1	1	GA05331010	
R738	1	1	1	GA05331010	

REF. DESIG.	QTY			PART NO.	DESCRIPTION
	U	E	P		
QN13	4	4	4	GG05271140	270 Ω
QN16					
QN01	1	1	1	HT309452A0	P701-SEMICONDUCTORS Transistor 2SC945(Q or R) Transistor 2SC945(Q or R) Transistor 2SA733(Q or R) Transistor 2SA733(Q or R) Diode 1S2473 Diode 1S2473 Diode 1S2473 Diode 1S2473 Diode 1S2471 Diode 1S2471
QN02	1	1	1	HT309452A0	
QN03	1	1	1	HT107332A0	
QN04	1	1	1	HT107332A0	
QN05	1	1	1	HD20001210	
QN06	1	1	1	HD20001210	
QN07	1	1	1	HD20001210	
QN08	1	1	1	HD20001210	
QN09	1	1	1	HD20003210	
QN10	1	1	1	HD20003210	
QN11	1	1	1	HD20003210	Diode 1S2471
QN12	1	1	1	HD20003210	Diode 1S2471
QN17	1	1	1	HT309452A0	Transistor 2SC945(Q or R)
QN18	1	1	1	HT309452A0	Transistor 2SC945(Q or R)
Q701	1	1	1	HT323442A0	Transistor 2SC2344(D or E)
Q702	1	1	1	HT323442A0	Transistor 2SC2344(D or E)
Q703	1	1	1	HT110112A0	Transistor 2SA1011(D or E)
Q704	1	1	1	HT110112A0	Transistor 2SA1011(D or E)
Q705	1	1	1	HT328382B0	Transistor 2SC2838(O or Y)
Q706	1	1	1	HT328382B0	Transistor 2SC2838(O or Y)
Q707	1	1	1	HT111872B0	Transistor 2SA1187(O or Y)
Q708	1	1	1	HT111872B0	Transistor 2SA1187(O or Y)
Q709	1	1	1	HD20015030	Diode DS135D
Q710	1	1	1	HD20015030	Diode DS135D
Q711	1	1	1	HD20015030	Diode DS135D
Q712	1	1	1	HD20015030	Diode DS135D
Q713	1	1	1	HT309452A0	Transistor 2SC945(Q or R)
Q714	1	1	1	HT309452A0	Transistor 2SC945(Q or R)
J701	1	1	1	YP06001060	P701-MISCELLANEOUS Plug, (7P) Plug, (7P)
J702	1	1	1	YP06001060	
L701	1	1	1	LL23905120	Choke Coil
L702	1	1	1	LL23905120	Choke Coil
P800	1	1	1	YK104H1910	P800-POWER SUPPLY CIRCUIT BOARD P.W. Board, Power Supply P.W. Board Assembly P.W. Board Assembly
	1	1	1	ZZ104H1910	
	1	1	1	ZZ104H8910	
Δ C801	1	1	1	DK18103560	P800-CAPACITORS Ceramic 0.01 μ F Elect 10000 μ F 63V Elect 10000 μ F 63V Elect 4.7 μ F 50V Elect 10 μ F 63V Elect 10 μ F 63V Elect 22 μ F 50V Elect 22 μ F 50V Elect 100 μ F 25V Elect 100 μ F 25V Elect 100 μ F 25V Elect 100 μ F 25V Elect 47 μ F 35V Elect 220 μ F 50V Elect 220 μ F 50V
Δ C803	1	1	1	EB10906320	
Δ C804	1	1	1	EB10906320	
C805	1	1	1	EA47505030	
C806	1	1	1	EA10606330	
C807	1	1	1	EA10606330	
C808	1	1	1	EA22605030	
C809	1	1	1	EA22605030	
C810	1	1	1	EA10702530	
C811	1	1	1	EA10702530	
C812	1	1	1	EA10702530	
C813	1	1	1	EA10702530	
C814	1	1	1	EA47603530	
C815	1	1	1	EA22705030	
C816	1	1	1	EA22705030	

- (U): for U.S.A.
- (E): for Europe
- (P): for PX

REF. DESIG.	Q'TY			PART NO.	DESCRIPTION
	U	E	P		
C817	1	1	1	EA10505030	Elect 1μF 50V
C818	1	1	1	EA10701030	Elect 100μF 10V
C819	1	1	1	EA10701030	Elect 100μF 10V
C820	1	1	1	EA22601630	Elect 22μF 16V
C821	1	1	1	EA10505030	Elect 1μF 50V
C822	1	1	1	EA33705030	Elect 330μF 50V
C823	1	1	1	EA10701030	Elect 100μF 10V
C824	1	1	1	EA47603530	Elect 47μF 35V
C825	1	1	1	EA10505030	Elect 1μF 50V
△ C826	1	1	1	DK18103560	Ceramic 0.01μF
△ C827	1	1	1	DK18103560	Ceramic 0.01μF
△ C828	1	1	1	DK18103560	Ceramic 0.01μF
△ C829	1	1	1	DK18103560	Ceramic 0.01μF
P800-RESISTORS (All Resistors are ±5% and ¼W)					
R801	1	1	1	GD05273140	27KΩ
R802	1	1	1	GP05131050	130Ω 5W
R803	1	1	1	GP05331030	330Ω 3W
R804	1	1	1	GG05102140	1KΩ
R805	1	1	1	GG05102140	1KΩ
R806	1	1	1	GD05221140	220Ω
R807	1	1	1	GD05681140	680Ω
R808	1	1	1	GD05473140	47KΩ
R809	1	1	1	GA05271010	270Ω
R810	1	1	1	GD05103140	10KΩ
R811	1	1	1	GD05103140	10KΩ
R812	1	1	1	GD05563140	56KΩ
R813	1	1	1	GG05152140	1.5KΩ
R814	1	1	1	GD05104140	100KΩ
R815	1	1	1	GD05220140	22Ω
R815	1	1	1	GD05100140	10Ω
R816	1	1	1	GD05473140	47KΩ
R817	1	1	1	GD05183140	18KΩ
R818	1	1	1	GD05103140	10KΩ
R819	1	1	1	GG05391120	390Ω ¼W
R820	1	1	1	GA05331010	330Ω 1W
R821	1	1	1	GD05822140	8.2KΩ
P800-SEMICONDUCTORS					
△ Q801	1	1	1	HD20011290	Diode S3V20
△ Q802	1	1	1	HD20011290	Diode S3V20
△ Q803	1	1	1	HD20011290	Diode S3V20
△ Q804	1	1	1	HD20011290	Diode S3V20
Q805	1	1	1	HD20001210	Diode 1S2473
Q806	1	1	1	HT403131Q0	Transistor 2SD313(E)
Q807	1	1	1	HT205071Q0	Transistor 2SB507(E)
△ Q808	1	1	1	HD20018030	Diode DBA-10
Q809	1	1	1	HD20001210	Diode 1S2473
Q810	1	1	1	HD30065090	Zener BZ-280
Q811	1	1	1	HD30053090	Zener XZ-068
Q812	1	1	1	HD403131Q0	Transistor 2SD313(E)
Q813	1	1	1	HD30009060	Zener RD-6.2EB
Q814	1	1	1	HT309452A0	Transistor 2SC945(Q or R)
Q815	1	1	1	HD20015030	Diode DS135D
Q816	1	1	1	HD20001210	Diode 1S2473
Q817	1	1	1	HD30065090	Zener BZ-280
Q818	1	1	1	HT107332A0	Transistor 2SA733(Q or R)
Q819	1	1	1	HD20001210	Diode 1S2473
Q820	1	1	1	HT309452A0	Transistor 2SC945(Q or R)

REF. DESIG.	Q'TY			PART NO.	DESCRIPTION
	U	E	P		
Q821	1	1	1	HD30014060	Zener RD22EB2
Q822	1	1	1	HD30014060	Zener RD22EB2
Q823	1	1	1	HD20001210	Diode 1S2473
P800-MISCELLANEOUS					
J822	1	1	1	YJ06002440	Jack (4P)
J824	1	1	1	YJ06002390	Jack (5P)
PC50-SCAN STEP SWITCH CIRCUIT BOARD					
PC50	1	1	1	YK103H1760	P.W. Board, Scan Step Switch
	1	1	1	ZZ103H1760	P.W. Board Assembly
SC51	1	1	1	SS02030130	Slide Switch, Scan Step
WC56	1	1	1	YU03500260	Jumper Lead, (3P)
PE00-TONE AMP. CIRCUIT BOARD					
PE00	1	1	1	YK104H1920	P.W. Board, Tone Amp.
	1	1	1	ZZ104H1920	P.W. Board Assembly
PE00-CAPACITORS					
CE01	1	1	1	EA10505030	Elect 1μF 50V
CE02	1	1	1	EA10505030	Elect 1μF 50V
CE03	1	1	1	DK16391300	Ceramic 390pF ±10%
CE04	1	1	1	DK16391300	Ceramic 390pF ±10%
CE05	1	1	1	EA10602530	Elect 10μF 25V
CE06	1	1	1	EA10602530	Elect 10μF 25V
CE07	1	1	1	EA47505030	Elect 4.7μF 50V
CE08	1	1	1	EA47505030	Elect 4.7μF 50V
CE09	1	1	1	EA10701030	Elect 100μF 10V
CE10	1	1	1	EA10701030	Elect 100μF 10V
CE11	1	1	1	EA10701030	Elect 100μF 10V
CE12	1	1	1	EA10701030	Elect 100μF 10V
CE43	1	1	1	EA10702530	Elect 100μF 10V
CE44	1	1	1	EA10702530	Elect 100μF 10V
PE00-RESISTORS (All Resistors are ±5% and ¼W)					
RE01	1	1	1	GD05221140	220Ω
RE02	1	1	1	GD05221140	220Ω
RE03	1	1	1	GD05823140	82KΩ
RE04	1	1	1	GD05823140	82KΩ
RE05	1	1	1	GD05561140	560Ω
RE06	1	1	1	GD05561140	560Ω
RE07	1	1	1	GD05392140	3.9KΩ
RE08	1	1	1	GD05392140	3.9KΩ
RE09	1	1	1	GD05104140	100KΩ
RE10	1	1	1	GD05104140	100KΩ
RE11	1	1	1	GD05391140	390Ω
RE12	1	1	1	GD05391140	390Ω
RE13	1	1	1	GD05223140	22KΩ
RE14	1	1	1	GD05223140	22KΩ
RE15	1	1	1	GD05221140	220Ω
RE16	1	1	1	GD05221140	220Ω
RE17	1	1	1	GD05392140	3.9KΩ
RE18	1	1	1	GD05392140	3.9KΩ
RE19	1	1	1	GD05332140	3.3KΩ
RE20	1	1	1	GD05332140	3.3KΩ
RE66	1	1	1	GG05101140	100Ω
RE67	1	1	1	GG05101140	100Ω
RE69	1	1	1	GA05180010	18Ω

- (U): for U.S.A.
- (E): for Europe
- (P): for PX

REF. DESIG.	Q'TY			PART NO.	DESCRIPTION
	U	E	P		
QE01	1	1	1	HC10013370	PE00-ICs IC TL4558PB
QE02	1	1	1	HC10013370	IC TL4558PB
JE01	1	1	1	YJ06002390	PE00-JACK Jack, (5P)
JE02	1	1	1	YJ06002390	Jack, (5P)
PE01	1	1	1	YK104H1930	PE01-CONNECTION CIRCUIT BOARD P.W. Board, Connection
	1	1	1	ZZ104H1930	P.W. Board Assembly
CE45	1	1	1	EA10701630	PE01-CAPACITORS Elect 100 μ F 16V
CE46	1	1	1	EA10701630	Elect 100 μ F 16V
RE68	1	1	1	GD05272140	PE01-RESISTOR 2.7K Ω \pm 5% $\frac{1}{4}$ W
QE13	1	1	1	HD30027090	PE01-SEMICONDUCTORS Zener WZ-140
QE14	1	1	1	HT40313100	Transistor 2SD313V(E)
PE02	1	1	1	YK104H1940	PE02-TONE AMP. CIRCUIT BOARD P.W. Board, Tone Amp.
	1	1	1	ZZ104H1940	P.W. Board Assembly
CE13	1	1	1	EA22505030	PE02-CAPACITORS Elect 2.2 μ F 50V
CE14	1	1	1	EA22505030	Elect 2.2 μ F 50V
CE15	1	1	1	EA47405030	Elect 0.47 μ F 50V
CE16	1	1	1	EA47405030	Elect 0.47 μ F 50V
CE17	1	1	1	DF17154300	Film 0.15 μ F \pm 20%
CE18	1	1	1	DF17154300	Film 0.15 μ F \pm 20%
CE19	1	1	1	DF17333300	Film 0.033 μ F \pm 20%
CE20	1	1	1	DF17333300	Film 0.033 μ F \pm 20%
CE21	1	1	1	DF17822300	Film 8200pF \pm 20%
CE22	1	1	1	DF17822300	Film 8200pF \pm 20%
CE23	1	1	1	EA10405030	Elect 0.1 μ F 50V
CE24	1	1	1	EA10405030	Elect 0.1 μ F 50V
CE25	1	1	1	DF17223300	Film 0.022 μ F \pm 20%
CE26	1	1	1	DF17223300	Film 0.022 μ F \pm 20%
CE27	1	1	1	DF17562300	Film 5600pF \pm 20%
CE28	1	1	1	DF17562300	Film 5600pF \pm 20%
CE29	1	1	1	DF17152300	Film 1500pF \pm 20%
CE30	1	1	1	DF17152300	Film 1500pF \pm 20%
CE31	1	1	1	DK16391300	Ceramic 390pF \pm 10%
CE32	1	1	1	DK16391300	Ceramic 390pF \pm 10%
CE33	1	1	1	DD15220370	Ceramic 22pF \pm 5%
CE34	1	1	1	DD15220370	Ceramic 22pF \pm 5%
CE35	1	1	1	DD15220370	Ceramic 22pF \pm 5%
CE36	1	1	1	DD15220370	Ceramic 22pF \pm 5%
CE37	1	1	1	DD15220370	Ceramic 22pF \pm 5%
CE38	1	1	1	DD15220370	Ceramic 22pF \pm 5%
CE39	1	1	1	DD15220370	Ceramic 22pF \pm 5%
CE40	1	1	1	DD15220370	Ceramic 22pF \pm 5%
CE41	1	1	1	DD15220370	Ceramic 22pF \pm 5%
CE42	1	1	1	DD15220370	Ceramic 22pF \pm 5%

REF. DESIG.	Q'TY			PART NO.	DESCRIPTION
	U	E	P		
RE21	1	1	1	GD05101140	PE02-RESISTORS (All Resistors are \pm 5% and $\frac{1}{4}$ W) 100 Ω
RE22	1	1	1	GD05101140	100 Ω
RE23	1	1	1	GD05101140	100 Ω
RE24	1	1	1	GD05101140	100 Ω
RE25	1	1	1	GD05101140	100 Ω
RE26	1	1	1	GD05101140	100 Ω
RE27	1	1	1	GD05101140	100 Ω
RE28	1	1	1	GD05101140	100 Ω
RE29	1	1	1	GD05101140	100 Ω
RE30	1	1	1	GD05101140	100 Ω
RE31	1	1	1	GD05473140	47K Ω
RE32	1	1	1	GD05473140	47K Ω
RE33	1	1	1	GD05473140	47K Ω
RE34	1	1	1	GD05473140	47K Ω
RE35	1	1	1	GD05473140	47K Ω
RE36	1	1	1	GD05473140	47K Ω
RE37	1	1	1	GD05473140	47K Ω
RE38	1	1	1	GD05473140	47K Ω
RE39	1	1	1	GD05473140	47K Ω
RE40	1	1	1	GD05473140	47K Ω
RE41	1	1	1	GD05472140	4.7K Ω
RE42	1	1	1	GD05472140	4.7K Ω
RE43	1	1	1	GD05472140	4.7K Ω
RE44	1	1	1	GD05472140	4.7K Ω
RE45	1	1	1	GD05472140	4.7K Ω
RE46	1	1	1	GD05472140	4.7K Ω
RE47	1	1	1	GD05472140	4.7K Ω
RE48	1	1	1	GD05472140	4.7K Ω
RE49	1	1	1	GD05472140	4.7K Ω
RE50	1	1	1	GD05472140	4.7K Ω
RE51	1	1	1	GD05102140	1K Ω
RE52	1	1	1	GD05102140	1K Ω
RE53	1	1	1	GD05102140	1K Ω
RE54	1	1	1	GD05102140	1K Ω
RE55	1	1	1	GD05102140	1K Ω
RE56	1	1	1	GD05102140	1K Ω
RE57	1	1	1	GD05102140	1K Ω
RE58	1	1	1	GD05102140	1K Ω
RE59	1	1	1	GD05102140	1K Ω
RE60	1	1	1	GD05102140	1K Ω
QE03	1	1	1	HT323622B0	PE02-SEMICONDUCTORS Transistor 2SC2362(G or H)
QE04	1	1	1	HT323622B0	Transistor 2SC2362(G or H)
QE05	1	1	1	HT323622B0	Transistor 2SC2362(G or H)
QE06	1	1	1	HT323622B0	Transistor 2SC2362(G or H)
QE07	1	1	1	HT323622B0	Transistor 2SC2362(G or H)
QE08	1	1	1	HT323622B0	Transistor 2SC2362(G or H)
QE09	1	1	1	HT323622B0	Transistor 2SC2362(G or H)
QE10	1	1	1	HT323622B0	Transistor 2SC2362(G or H)
QE11	1	1	1	HT323622B0	Transistor 2SC2362(G or H)
QE12	1	1	1	HT323622B0	Transistor 2SC2362(G or H)
WE02	1	1	1	YU08100260	PE02-MISCELLANEOUS Jumper Lead, (8P)
WE03	1	1	1	YU08100260	Jumper Lead, (8P)

- (U): for U.S.A.
- (E): for Europe
- (P): for PX

REF. DESIG.	Q'TY			PART NO.	DESCRIPTION
	U	E	P		
PE03	1	1	1	YK104H1950	PE03-TONE VOLUME CIRCUIT BOARD P.W. Board, Tone Volume P.W. Board Assembly
	1	1	1	ZZ104H1950	
RE61	1	1	1	RS05030380	PE03-RESISTORS 50K Ω (W), Variable
RE62	1	1	1	RS05030380	
RE63	1	1	1	RS05030380	
RE64	1	1	1	RS05030380	
RE65	1	1	1	RS05030380	
PG00	1	1	1	YK104H1960	PG00-VOL/VALANCE CIRCUIT BOARD P.W. Board, Vol/Balance P.W. Board Assembly
	1	1	1	ZZ104H1960	
RG01	1	1	1	RM01040270	Variable Resistor 100K Ω (B)
RG02	1	1	1	RK02040120	Variable Resistor 200K Ω (W)
WE01	1	1	1	YU05480260	Jumper Lead, (5P)
PJ01	1	1	1	YH104H0210	PJ01-TAPE MONITOR SWITCH CIRCUIT BOARD P.W. Board, Tape Monitor Switch P.W. Board Assembly
	1	1	1	ZZ104H0210	
CJ01	1	1	1	DK17103300	Ceramic Cap. 0.01 μ F \pm 20%
JJ01	1			YT02040350	Terminal, Tape 1
JJ01		1	1	YT02040340	Terminal, Tape 1
JJ02	1			YT02040350	Terminal, Tape 2
JJ02		1	1	YT02040340	Terminal, Tape 2
SJ01	1	1	1	SS06060010	Slide Switch
SJ02	1	1	1	SR00050100	Rotary Switch
WJ01	1	1	1	YU07160260	Jumper Lead, (7P)
PK01	1	1	1	YK104H1990	PK01-EQ OUT CIRCUIT BOARD P.W. Board, EQ out P.W. Board Assembly
	1	1	1	ZZ104H1990	
RK01	1	1	1	GD05103140	Resistor 10K Ω \pm 5% $\frac{1}{4}$ W
RK02	1	1	1	GD05103140	Resistor 10K Ω \pm 5% $\frac{1}{4}$ W
RK03	1	1	1	GD05681140	Resistor 680 Ω \pm 5% $\frac{1}{4}$ W
RK04	1	1	1	GD05681140	Resistor 680 Ω \pm 5% $\frac{1}{4}$ W
JK01	1	1	1	YJ01001340	Jack, EQ Out

REF. DESIG.	Q'TY			PART NO.	DESCRIPTION
	U	E	P		
PL00	1	1	1	YK104H1970	PL00-SPEAKER PROTECTOR CIRCUIT BOARD P.W. Board, Speaker Protector P.W. Board Assembly
	1	1	1	ZZ104H1970	
RL01	1	1	1	GG05152120	Resistor 1.5K Ω \pm 5% $\frac{1}{4}$ W
RL02	1	1	1	GG05152120	Resistor 1.5K Ω \pm 5% $\frac{1}{4}$ W
QL01	1	1	1	HD20015030	Diode DS135D
QL02	1	1	1	HD20015030	Diode DS135D
JL01	1	1	1	YT03080010	Terminal, Speaker
LL01	1	1	1	LY20240190	Relay, System 1
LL02	1	1	1	LY20240190	Relay, System 2
PQ00	1	1	1	YK104H1980	PQ00-AC POWER RELAY CIRCUIT BOARD P.W. Board, AC Power Relay P.W. Board Assembly P.W. Board Assembly P.W. Board Assembly
	1			ZZ104H1980	
		1	ZZ104H8980		
		1	ZZ104H9980		
CQ01	1			DK18103530	PQ00-CAPACITORS Ceramic 0.01 μ F 125V Ceramic 0.01 μ F 400V Ceramic 0.01 μ F 250V Ceramic 0.01 μ F 400V Ceramic 0.01 μ F 250V
CQ01		1		DK18103840	
CQ01			1	DK18103850	
CQ02		1		DK18103840	
CQ02			1	DK18103850	
QQ01	1	1	1	HD20015030	PQ00-SEMICONDUCTOR Diode DS135D
LQ01	1	1	1	LY10240050	PQ00-MISCELLANEOUS Relay Relay
		1	1	LY10240050	
PS00	1	1	1	YK103H3430	PS00-FILTER/LOUDNESS CIRCUIT BOARD P.W. Board, Filter/Loudness P.W. Board Assembly
	1	1	1	ZZ103H3430	
CS01	1	1	1	DF15473300	PS00-CAPACITORS Film 0.047 μ F \pm 5% Film 0.047 μ F \pm 5% Ceramic 680pF \pm 10% Ceramic 680pF \pm 10% Film 5600pF \pm 5% Film 5600pF \pm 5% Elect 0.1 μ F 50V Elect 0.1 μ F 50V Elect 0.01 μ F
CS02	1	1	1	DF15473300	
CS03	1	1	1	DK16681300	
CS04	1	1	1	DK16681300	
CS05	1	1	1	DF15562300	
CS06	1	1	1	DF15562300	
CS07	1	1	1	EA10405030	
CS08	1	1	1	EA10405030	
CS09	1	1	1	EA10405030	

- (U): for U.S.A.
- (E): for Europe
- (P): for PX

REF. DESIG.	Q'TY			PART NO.	DESCRIPTION
	U	E	P		
PS00-RESISTORS (All Resistors are $\pm 5\%$ and $\frac{1}{4}W$)					
RS01	1	1	1	GD05822140	8.2K Ω
RS02	1	1	1	GD05822140	8.2K Ω
RS03	1	1	1	GD05183140	18K Ω
RS04	1	1	1	GD05183140	18K Ω
RS05	1	1	1	GD05222140	2.2K Ω
RS06	1	1	1	GD05222140	2.2K Ω
RS07	1	1	1	GD05222140	2.2K Ω
RS08	1	1	1	GD05222140	2.2K Ω
RS09	1	1	1	GD05564140	560K Ω
RS10	1	1	1	GD05564140	560K Ω
RS13	1	1	1	GD05332140	3.3K Ω
RS14	1	1	1	GD05332140	3.3K Ω
RS15	1	1	1	GD05123140	12K Ω
RS21	1	1	1	GD05823140	82K Ω
RS22	1	1	1	GD05823140	82K Ω
PS00-MISCELLANEOUS					
JS01	1	1	1	YJ06002430	Jack, (3P)
JS02	1	1	1	YJ06002430	Jack, (3P)
SS01	1	1	1	SP02090010	Push Switch, Speaker/Filter
WS01	1	1	1	YU05280260	Jumper Lead, (5P)
WS04	1	1	1	YU05220260	Jumper Lead, (5P)
PS01-SPEAKER SWITCH CIRCUIT BOARD					
PS01	1	1	1	YK103H3440	P.W. Board, Speaker Switch
	1	1	1	ZZ103H3440	P.W. Board Assembly
PS01-RESISTORS					
RS16	1	1	1	GD05104140	100K Ω $\pm 5\%$ $\frac{1}{4}W$
RS17	1	1	1	GG05392120	3.9K Ω $\pm 5\%$ $\frac{1}{2}W$
RS18	1	1	1	GD05104140	100K Ω $\pm 5\%$ $\frac{1}{4}W$
RS19	1	1	1	GG05222120	2.2K Ω $\pm 5\%$ $\frac{1}{2}W$
RS20	1	1	1	GD05104140	100K Ω $\pm 5\%$ $\frac{1}{4}W$
PS01-SEMICONDUCTORS					
QS01	1	1	1	HT309452A0	Transistor 2SC945(Q or R)
QS02	1	1	1	HT309452A0	Transistor 2SC945(Q or R)
PS01-JACK					
JS03	1	1	1	YJ06002430	Jack, (3P)
PS50-TIMER SWITCH CIRCUIT BOARD					
PS50	1	1	1	YK103H1740	P.W. Board, Timer Switch
	1	1	1	ZZ103H1740	P.W. Board Assembly
PS50-SEMICONDUCTORS					
QS51	1	1	1	HD20001210	Diode 1S2473
QS52	1	1	1	HD20001210	Diode 1S2473
QS53	1	1	1	HD20001210	Diode 1S2473
QS54	1	1	1	HD20011050	Diode 1S1555
QS55	1	1	1	HD20011050	Diode 1S1555
QS56	1	1	1	HD20011050	Diode 1S1555

REF. DESIG.	Q'TY			PART NO.	DESCRIPTION
	U	E	P		
SS51	1	1	1	SR01060010	PS50-MISCELLANEOUS Rotary Switch, Timer
WS55	1	1	1	YU07240260	Jumper Lead, (7P)
PT00-KEY BOARD SWITCH CIRCUIT BOARD					
PT00	1	1	1	YK103H2760	P.W. Board, Key Board Switch
	1	1	1	ZZ103H2760	P.W. Board Assembly
RT01	1	1	1	GD05681140	Resistors 680 Ω $\pm 5\%$ $\frac{1}{4}W$
PT00-SEMICONDUCTORS					
QT01	1	1	1	HI10003320	L.E.D. GL-2PR1
QT02	1	1	1	HI10003320	L.E.D. GL-2PR1
QT03	1	1	1	HI10003320	L.E.D. GL-2PR1
QT04	1	1	1	HI10003320	L.E.D. GL-2PR1
QT05	1	1	1	HI10003320	L.E.D. GL-2PR1
QT06	1	1	1	HI10003320	L.E.D. GL-2PR1
QT07	1	1	1	HI10003320	L.E.D. GL-2PR1
QT08	1	1	1	HI10003320	L.E.D. GL-2PR1
PT00-SWITCHES					
ST01	1	1	1	SP01010470	Push Switch, Memory 1
ST02	1	1	1	SP01010470	Push Switch, Memory 2
ST03	1	1	1	SP01010470	Push Switch, Memory 3
ST04	1	1	1	SP01010470	Push Switch, Memory 4
ST05	1	1	1	SP01010470	Push Switch, Memory 5
ST06	1	1	1	SP01010470	Push Switch, Memory 6
ST07	1	1	1	SP01010470	Push Switch, Memory 7
ST08	1	1	1	SP01010470	Push Switch, Memory 8
ST09	1	1	1	SP01010470	Push Switch, Time 9
ST10	1	1	1	SP01010470	Push Switch, Time 0
ST11	1	1	1	SP01010470	Push Switch, Memory
ST12	1	1	1	SP01010470	Push Switch, Up
ST13	1	1	1	SP01010470	Push Switch, Down
WT01	1	1	1	YU08180260	Jumper Lead, (8P)
WT02	1	1	1	YU07200260	Jumper Lead, (7P)
WT11	1	1	1	YB01300040	Connective Cord, (8P)
PT50-POWER OFF SWITCH CIRCUIT BOARD					
PT50	1	1	1	YK103H2770	P.W. Board, Power OFF Switch
	1	1	1	ZZ103H2770	P.W. Board Assembly
ST51	1	1	1	SP01010470	Push Switch, Power OFF
WT57	1	1	1	YU02400260	Jumper Lead, (2P)

- (U): for U.S.A.
- (E): for Europe
- (P): for PX

REF. DESIG.	Q'TY			PART NO.	DESCRIPTION
	U	E	P		
PU00	1	1	1	YK103H1730	PU00-FUNCTION SWITCH CIRCUIT BOARD P.W. Board, Function Switch
	1	1	1	ZZ103H1730	P.W. Board Assembly
RU01	1	1	1	GD05331140	Resistor 330Ω ±5% ¼W
PU00-SEMICONDUCTORS					
QU01	1	1	1	HI10012320	L.E.D. Aux
QU02	1	1	1	HI10012320	L.E.D. Phono
QU04	1	1	1	HI10012320	L.E.D. AM
QU05	1	1	1	HI10012320	L.E.D. FM
PU00-MISCELLANEOUS					
SU01	1	1	1	SP01010480	Push Switch, Aux
SU02	1	1	1	SP01010480	Push Switch, Phone
SU04	1	1	1	SP01010480	Push Switch, AM
SU05	1	1	1	SP01010480	Push Switch, FM
WU09	1	1	1	YU06160260	Jumper Lead, (6P)
WU10	1	1	1	YU05160260	Jumper Lead, (5P)

REF. DESIG.	Q'TY			PART NO.	DESCRIPTION
	U	E	P		
PU50	1	1	1	YK103H1720	PU50-C/F DISPLAY CIRCUIT BOARD P.W. Board, C/F Display
	1	1	1	ZZ103H1720	P.W. Board Assembly
RU51	1	1	1	GD05272140	Resistor 2.7KΩ ±5% ¼W
QU51	1	1	1	HD20001210	Diode 1S2473
SU51	1	1	1	SP02040100	Push Switch
WU54	1	1	1	YU06200260	Jumper Lead, (6P)
WU62	1	1	1	YU02180260	Jumper Lead, (2P)
CU51	1	1	1	DK17103300	Ceramic Cap. 0.01μF
PW01-HEAD PHONE CIRCUIT BOARD					
PW01	1	1	1	YK103H1770	P.W. Board, Head Phone
	1	1	1	ZZ103H1770	P.W. Board Assembly
JW01	1	1	1	YJ01001340	Jack, Head Phone

(W01-99) Assembly and Wiring

(T01-99) Adjustment

(X01-00) Correction

9. TECHNICAL SPECIFICATIONS

AMPLIFIER STAGE

RATED OUTPUT PER CHANNEL

4 OHMS DIN	95W
4 OHMS RMS	88W
8 OHMS DIN	75W
8 OHMS RMS	70W
TOTAL HARMONIC DISTORTION AT RMS 8 OHMS	0.03%
DAMPING FACTOR 8 OHMS (1 kHz)	50

PREAMP STAGE

Frequency Response	
Phono: (RIAA)	±1.0 dB (20 – 20 kHz)
Aux: (±2 dB)	16 Hz – 30 kHz
Signal/Noise Ratio	
Phono: 7.75 mV 20V out	81 dB
Aux: VOL MAX 20V out	96 dB
Input Sensitivity/Imp.	
Phono	2.7 mV/47 kΩ
Auxiliary	160 mV/27 kΩ

FM STAGE (87.5 – 108 MHz)

Sensitivity	
DIN Mono (S/N 26 dB, 75Ω)	1.0 μV
DIN Stereo (S/N 46 dB, 75Ω)	20 μV
Selectivity/Adjacent Channel 98 MHz	60 dB
Signal/Noise Ratio 98 MHz	
Unweighted: Mono	67 dB
Stereo	63 dB
Weighted: Mono	75 dB
Stereo	70 dB

MW STAGE (522 – 1611, 530 – 1620 kHz)

Sensitivity (20 dB S/N 30% mod., 1 MHz)	30 μV
Selectivity	30 dB

GENERAL

Power Requirements	220V AC, 50 Hz
	(E and N versions are featuring an external voltage selector for use on other voltages. Other versions can be converted by a qualified technician to operate on 240V.)
Power Consumption at Rated Output, Both Channels Operating	250W
Dimensions	
Panel Width	416 mm
Panel Height	117.5 mm
Depth	388 mm
Net Weight	11.0 kg

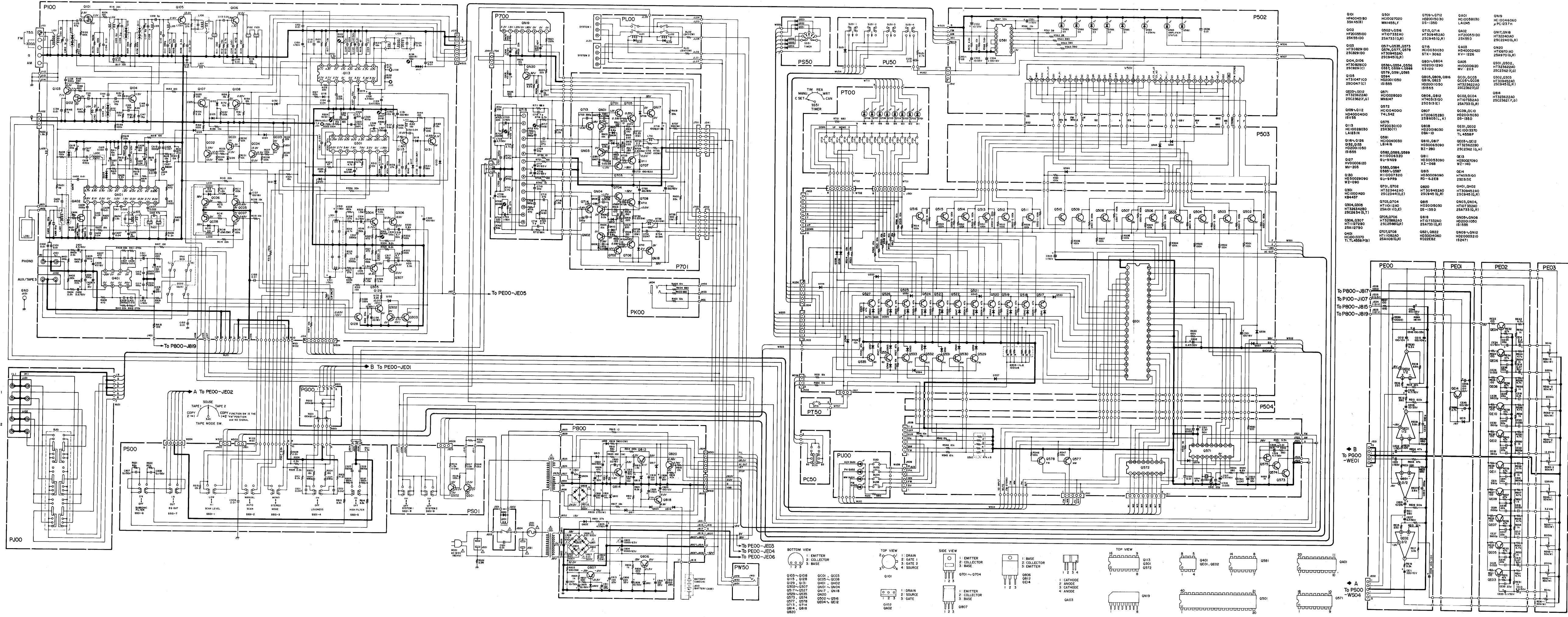

Note on safety: The parts marked with Δ are important parts on the safety. Please use the parts having the designated parts number without fail.

Components and wiring are subject to change for modification without notice.

10. SCHEMATIC DIAGRAM

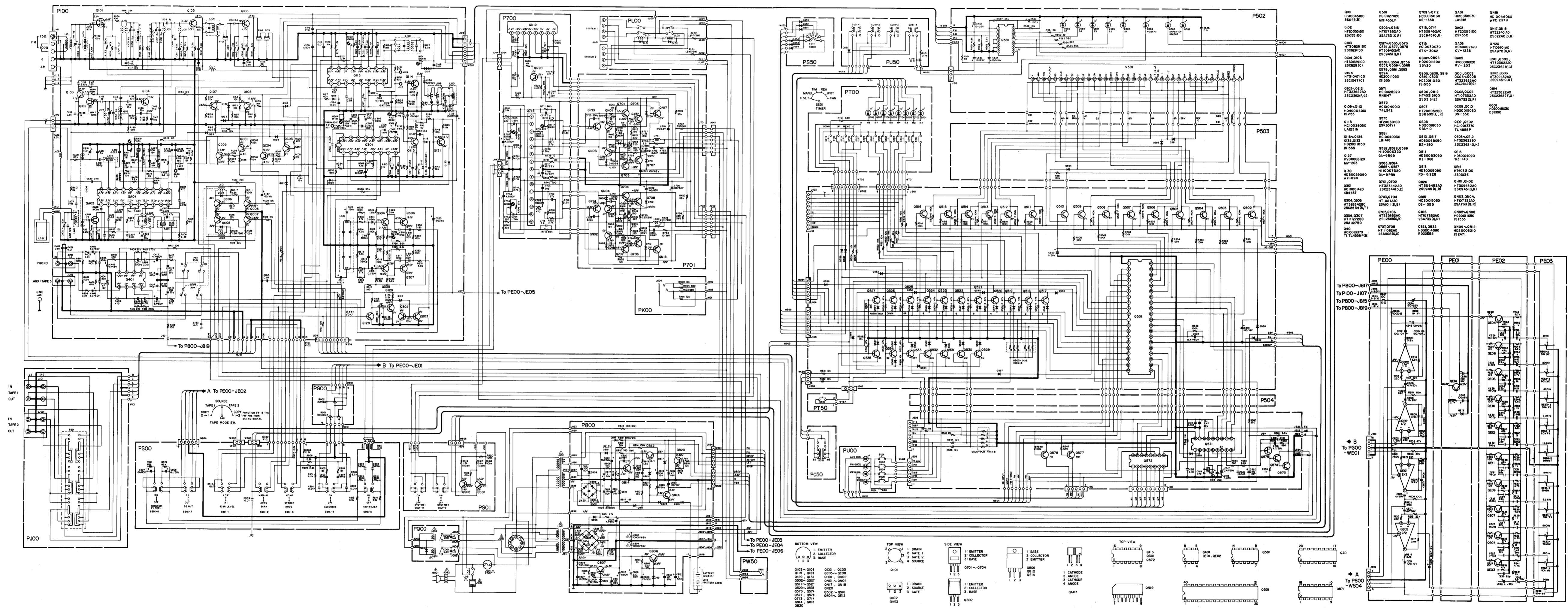

Q101 HF4004580 384-4581	Q102 HF2005000 250-5000	Q103 HT30889-00 250-8890	Q104, Q106 HT30889-00 250-8890	Q105 HT30447-00 250-4470	Q107 HT30447-00 250-4470	Q108 HT30447-00 250-4470	Q109 HT30447-00 250-4470	Q110 HT30447-00 250-4470	Q111 HT30447-00 250-4470	Q112 HT30447-00 250-4470	Q113 HT30447-00 250-4470	Q114 HT30447-00 250-4470	Q115 HT30447-00 250-4470	Q116 HT30447-00 250-4470	Q117 HT30447-00 250-4470	Q118 HT30447-00 250-4470	Q119 HT30447-00 250-4470	Q120 HT30447-00 250-4470	Q121 HT30447-00 250-4470	Q122 HT30447-00 250-4470	Q123 HT30447-00 250-4470	Q124 HT30447-00 250-4470	Q125 HT30447-00 250-4470	Q126 HT30447-00 250-4470	Q127 HT30447-00 250-4470	Q128 HT30447-00 250-4470	Q129 HT30447-00 250-4470	Q130 HT30447-00 250-4470	Q131 HT30447-00 250-4470	Q132 HT30447-00 250-4470	Q133 HT30447-00 250-4470	Q134 HT30447-00 250-4470	Q135 HT30447-00 250-4470	Q136 HT30447-00 250-4470	Q137 HT30447-00 250-4470	Q138 HT30447-00 250-4470	Q139 HT30447-00 250-4470	Q140 HT30447-00 250-4470	Q141 HT30447-00 250-4470	Q142 HT30447-00 250-4470	Q143 HT30447-00 250-4470	Q144 HT30447-00 250-4470	Q145 HT30447-00 250-4470	Q146 HT30447-00 250-4470	Q147 HT30447-00 250-4470	Q148 HT30447-00 250-4470	Q149 HT30447-00 250-4470	Q150 HT30447-00 250-4470	Q151 HT30447-00 250-4470	Q152 HT30447-00 250-4470	Q153 HT30447-00 250-4470	Q154 HT30447-00 250-4470	Q155 HT30447-00 250-4470	Q156 HT30447-00 250-4470	Q157 HT30447-00 250-4470	Q158 HT30447-00 250-4470	Q159 HT30447-00 250-4470	Q160 HT30447-00 250-4470	Q161 HT30447-00 250-4470	Q162 HT30447-00 250-4470	Q163 HT30447-00 250-4470	Q164 HT30447-00 250-4470	Q165 HT30447-00 250-4470	Q166 HT30447-00 250-4470	Q167 HT30447-00 250-4470	Q168 HT30447-00 250-4470	Q169 HT30447-00 250-4470	Q170 HT30447-00 250-4470	Q171 HT30447-00 250-4470	Q172 HT30447-00 250-4470	Q173 HT30447-00 250-4470	Q174 HT30447-00 250-4470	Q175 HT30447-00 250-4470	Q176 HT30447-00 250-4470	Q177 HT30447-00 250-4470	Q178 HT30447-00 250-4470	Q179 HT30447-00 250-4470	Q180 HT30447-00 250-4470	Q181 HT30447-00 250-4470	Q182 HT30447-00 250-4470	Q183 HT30447-00 250-4470	Q184 HT30447-00 250-4470	Q185 HT30447-00 250-4470	Q186 HT30447-00 250-4470	Q187 HT30447-00 250-4470	Q188 HT30447-00 250-4470	Q189 HT30447-00 250-4470	Q190 HT30447-00 250-4470	Q191 HT30447-00 250-4470	Q192 HT30447-00 250-4470	Q193 HT30447-00 250-4470	Q194 HT30447-00 250-4470	Q195 HT30447-00 250-4470	Q196 HT30447-00 250-4470	Q197 HT30447-00 250-4470	Q198 HT30447-00 250-4470	Q199 HT30447-00 250-4470	Q200 HT30447-00 250-4470
-------------------------------	-------------------------------	--------------------------------	--------------------------------------	--------------------------------	--------------------------------	--------------------------------	--------------------------------	--------------------------------	--------------------------------	--------------------------------	--------------------------------	--------------------------------	--------------------------------	--------------------------------	--------------------------------	--------------------------------	--------------------------------	--------------------------------	--------------------------------	--------------------------------	--------------------------------	--------------------------------	--------------------------------	--------------------------------	--------------------------------	--------------------------------	--------------------------------	--------------------------------	--------------------------------	--------------------------------	--------------------------------	--------------------------------	--------------------------------	--------------------------------	--------------------------------	--------------------------------	--------------------------------	--------------------------------	--------------------------------	--------------------------------	--------------------------------	--------------------------------	--------------------------------	--------------------------------	--------------------------------	--------------------------------	--------------------------------	--------------------------------	--------------------------------	--------------------------------	--------------------------------	--------------------------------	--------------------------------	--------------------------------	--------------------------------	--------------------------------	--------------------------------	--------------------------------	--------------------------------	--------------------------------	--------------------------------	--------------------------------	--------------------------------	--------------------------------	--------------------------------	--------------------------------	--------------------------------	--------------------------------	--------------------------------	--------------------------------	--------------------------------	--------------------------------	--------------------------------	--------------------------------	--------------------------------	--------------------------------	--------------------------------	--------------------------------	--------------------------------	--------------------------------	--------------------------------	--------------------------------	--------------------------------	--------------------------------	--------------------------------	--------------------------------	--------------------------------	--------------------------------	--------------------------------	--------------------------------	--------------------------------	--------------------------------	--------------------------------	--------------------------------	--------------------------------	--------------------------------	--------------------------------	--------------------------------

Note on safety: The parts marked with Δ are important parts on the safety. Please use the parts having the designated parts number without fail.

Components and wiring are subject to change for modification without notice.