

Service Manual

74SR-82 / 00B

Audio/Video surround stereo receiver

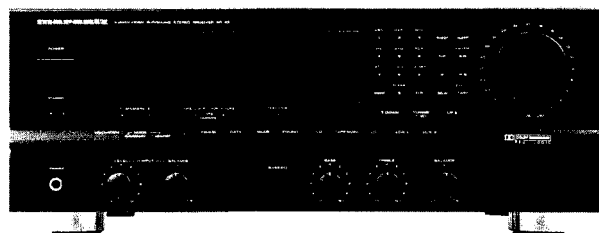

TABLE OF CONTENTS

SECTION	PAGE
1. TECHNICAL SPECIFICATIONS	3
2. BLOCK DIAGRAM	4
3. SCHEMATIC DIAGRAM AND PARTS LOCATION (Pattern side)	6
4. EXPLODED VIEW AND PARTS LIST	31
5. TEST EQUIPMENT REQUIRED FOR SERVICING	33
6. IDLING CURRENT ADJUSTMENT	33
7. DOLBY PEAK INDICATOR LIGHTING LEVEL CHECK	33
8. SERVICE PROGRAM	33
9. TUNER ALIGNMENT PROCEDURES	34
10. ALIGNMENT AND TEST POINT	36
11. CIRCUIT DESCRIPTION	36
12. MICROPROCESSOR DATA	41
13. ELECTRICAL PARTS LIST	42

marantz®

model SR-82

First issue : 1993
4822 725 51038
PCS 71 474

MARANTZ DESIGN AND SERVICE

Using superior design and selected high grade components, MARANTZ company has created the ultimate in stereo sound. Only **original MARANTZ parts** can insure that your MARANTZ product will continue to perform to the specifications for which it is famous.

Parts for your MARANTZ equipment are generally available at our National Marantz Subsidiary or Agent.

MARANTZ EUROPE B.V.
P.O. Box 80002
Building SFF 2
5600 JB Eindhoven
The Netherlands
Phone : +31-40-732241
Fax : +31-40-735578

ORDERING PARTS

Parts can be ordered either by mail or by telex. In both cases, the correct part number has to be specified. The following information must be supplied to eliminate delays in processing your order:

1. Complete address
2. Complete part numbers and quantities required
3. Description of parts
4. Model number for which the part is required
5. Way of shipment
6. Signature: any order form or telex must be signed, otherwise such part order will be considered as null and void.

ADDRESSES

AUSTRALIA
MARANTZ AUSTRALIA
Figtree Drive
Australia Centre
Homebush, NSW 2140
AUSTRALIA

FINLAND
MARANTZ
Kuortanegatan 1
00520
Helsingfors 52
Finland

ITALY
MARANTZ ITALIANA SPA
Piazza IV Novembre 3
20124 Milano
Italy

NORWAY
MARANTZ
Postboks 7034
Assiden
3007 Drammen
Norway

SPAIN
MARANTZ SPAIN
Martinez Villergas 2
Apartado 2065
Madrid 28027
Spain

AUSTRIA
MARANTZ
Hietzinger Kai 137a
1130 Wien
Austria

FRANCE
MARANTZ FRANCE
4 Rue Bernard Palissy
92600 Asnières
France

JAPAN
MARANTZ JAPAN INC.
35-1, 7-chome, Sagamiono
Sagamihara-shi, Kanagawa
Japan

PORTUGAL
COREL
Av. da Liberdade
211-2 Esq.
1200 Lisboa
Portugal

SWEDEN
MARANTZ
Box 1324
17125 Solna
Sweden

BELGIUM
MARANTZ EUROPE B.V.
Div. Benelux
P.O.Box 80002
Building SFF 2
5600 JB Eindhoven
The Netherlands

GERMANY
MARANTZ GERMANY GmbH
Kleine Heide 12
Postfach 4802
Halle-Westfalen
Germany

KUWAIT
AL ALAMIAH ELECTRONICS
P.O.Box 8196
Salmiah
22052 Kuwait

SAUDI ARABIA
AL ALAMIAH ELECTRONICS
P.O.Box 5954
University Street
Riyadh 11432
Saudi Arabia

SWITZERLAND
MARANTZ SWITZERLAND
Postfach
8010 Zürich-Müllingen
Switzerland

CHILE
MARANTZ DIVISION OF
PHILIPS S.A.
Av.Santa Maria 0760
Casilla 2687
Santiago
Chile

GREAT BRITAIN
MARANTZ HiFi UK Ltd.
Kingsbridge House
Padbury Oaks
575-583 Bath Road
Longford Middlesex UB7 0EH,
U.K.

NETHERLANDS
MARANTZ EUROPE B.V.
Div. Benelux
P.O.Box 80002
Building SFF 2
5600 JB Eindhoven
The Netherlands

SOUTH AFRICA
MARANTZ S.A.
10 Bond Street
Randburg 2194
P.O. Box 7703
Johannesburg 2000
South Africa

TRADING
MARANTZ TRADING
P.O.Box 20008
Building SFF 2
5600 JB Eindhoven
The Netherlands

DENMARK
MARANTZ
Horsvinget 5
2630 Tastrup
Denmark

GREECE
ADAMCO ELECTR. SA
P.O.Box 21025
Hippocrates Str. 188
Athens 11471
Greece

All of the above locations are fully equipped to take care of your total service needs or can advise you. Because various countries have differing configuration requirements, it is necessary that you contact the service facility in your particular country. In the event that there is no service location listed for your country, please contact the nearest facility for the necessary assistance.

In case of difficulties, do not hesitate to contact the Technical Department at above mentioned address.

1. TECHNICAL SPECIFICATIONS

FM Tuner Section

Frequency Range	87.5 - 108.0 MHz
Usable Sensitivity (mono / stereo)	1.0 / 25 μ V
Signal to Noise Ratio	Mono / Stereo 76 / 68 dB
Distortion	Mono / Stereo 0.1 / 0.6 %
Stereo Separation	1 kHz 40 dB
A.C.S. (Wide / Narrow)	\pm 300 kHz 55 / 75 dB
Image Rejection	98 MHz 50 dB

AM Tuner Section

Frequency Range	531 - 1602 kHz
Usable Sensitivity	Loop 500 μ V
Signal to Noise Ratio	50 dB
Distortion (1 kHz 30% Mod.)	0.5 %
Selectivity	\pm 18 kHz 40 dB

Audio Section

Rated Power	
Front	20 Hz - 20 kHz 8 ohms 70 W / Ch
(Main in) Center	40 Hz - 20 kHz 8 ohms 80 W
(Main in) Surround	40 Hz - 20 kHz 8 ohms 30 W / Ch
THD Front	20 Hz - 20 kHz 8 ohms 0.09%
Input Sensitivity / Impedance	
Phono	3.5 mV / 47 k ohms
Linear	220 mV / 40 k ohms
Front Main in	1.3 V / 20 k ohms
Center Main in	1.7 V / 20 k ohms
Surround Main in	1.0 V / 20 k ohms
Phono Overload (1 kHz, 1% THD)	
Phono	120 mV
Signal to Noise Ratio (IHF A)	
Phono	75 dB
Linear	82 dB

Video Section

Input / Output Level / Impedance	1.0 V _{p-p} / 75 ohms
--	--------------------------------

Others

Power Supply	AC 230 V 50 / 60 Hz
Power Consumption	50 W

Dimensions

Width	420 mm
Height	166 mm
Depth	430 mm
Weight	15.5 kg

Specifications subject to change without prior notice.

2. BLOCK DIAGRAM

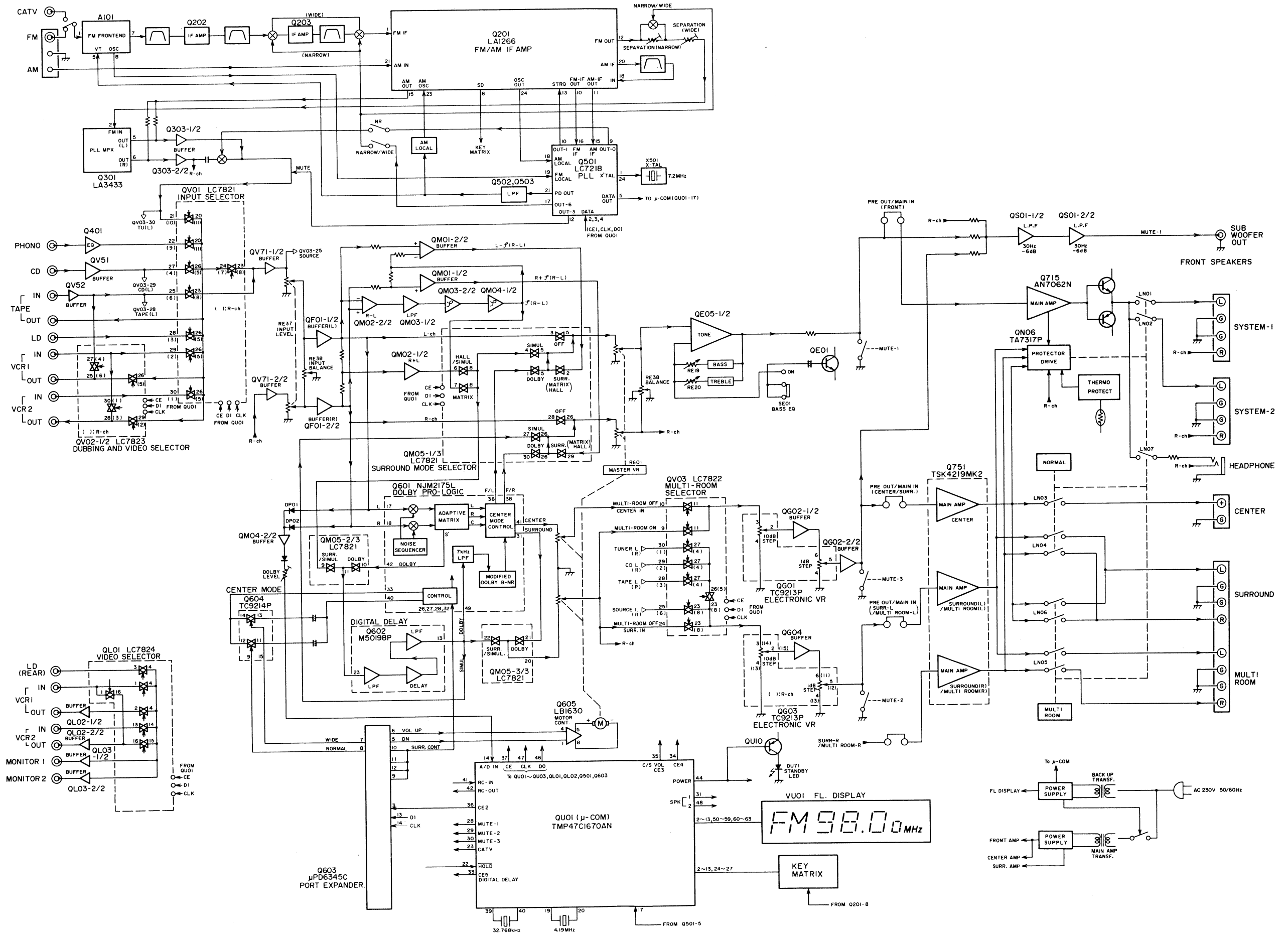

3. SCHEMATIC DIAGRAM AND PARTS LOCATION (Pattern side)

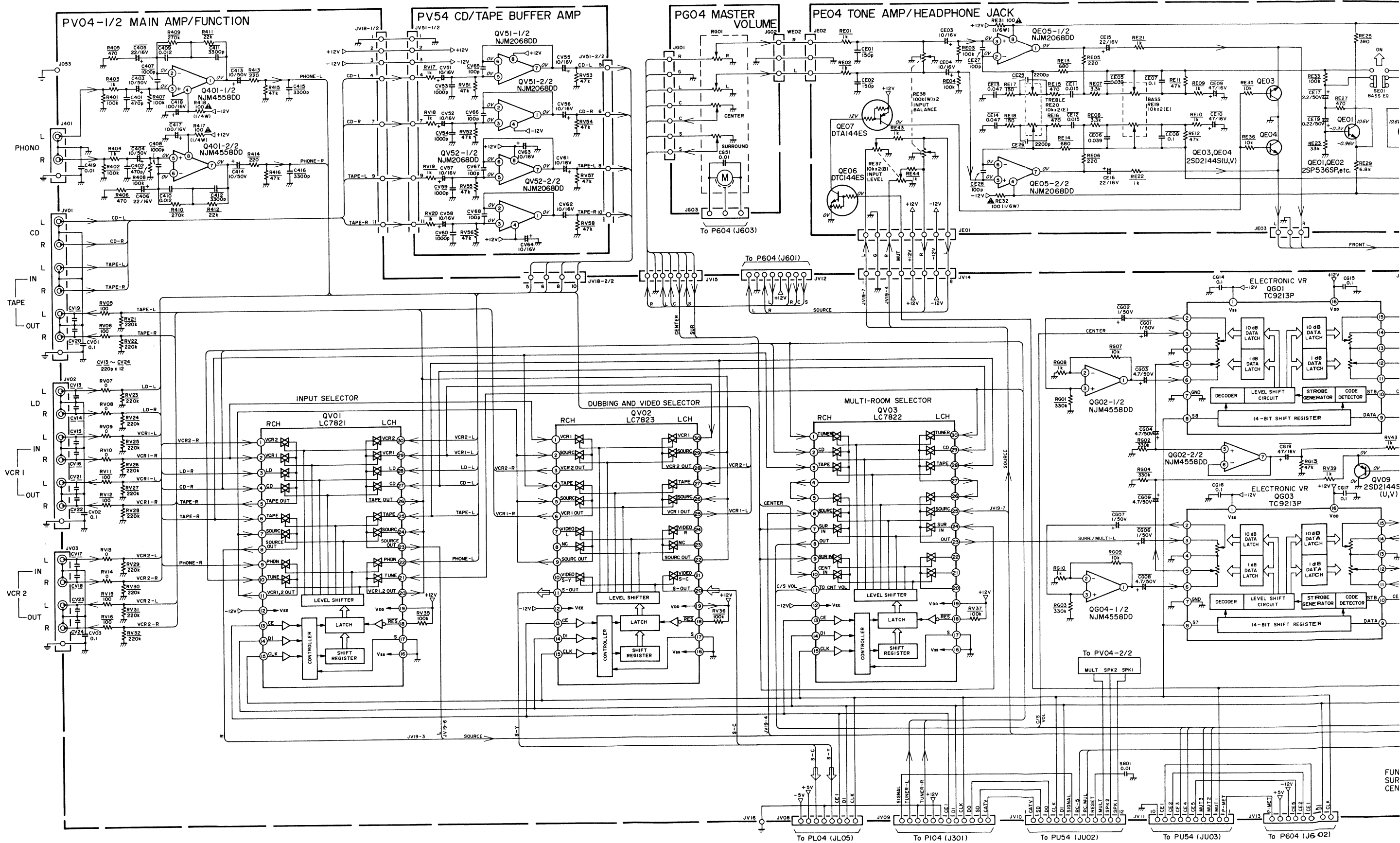

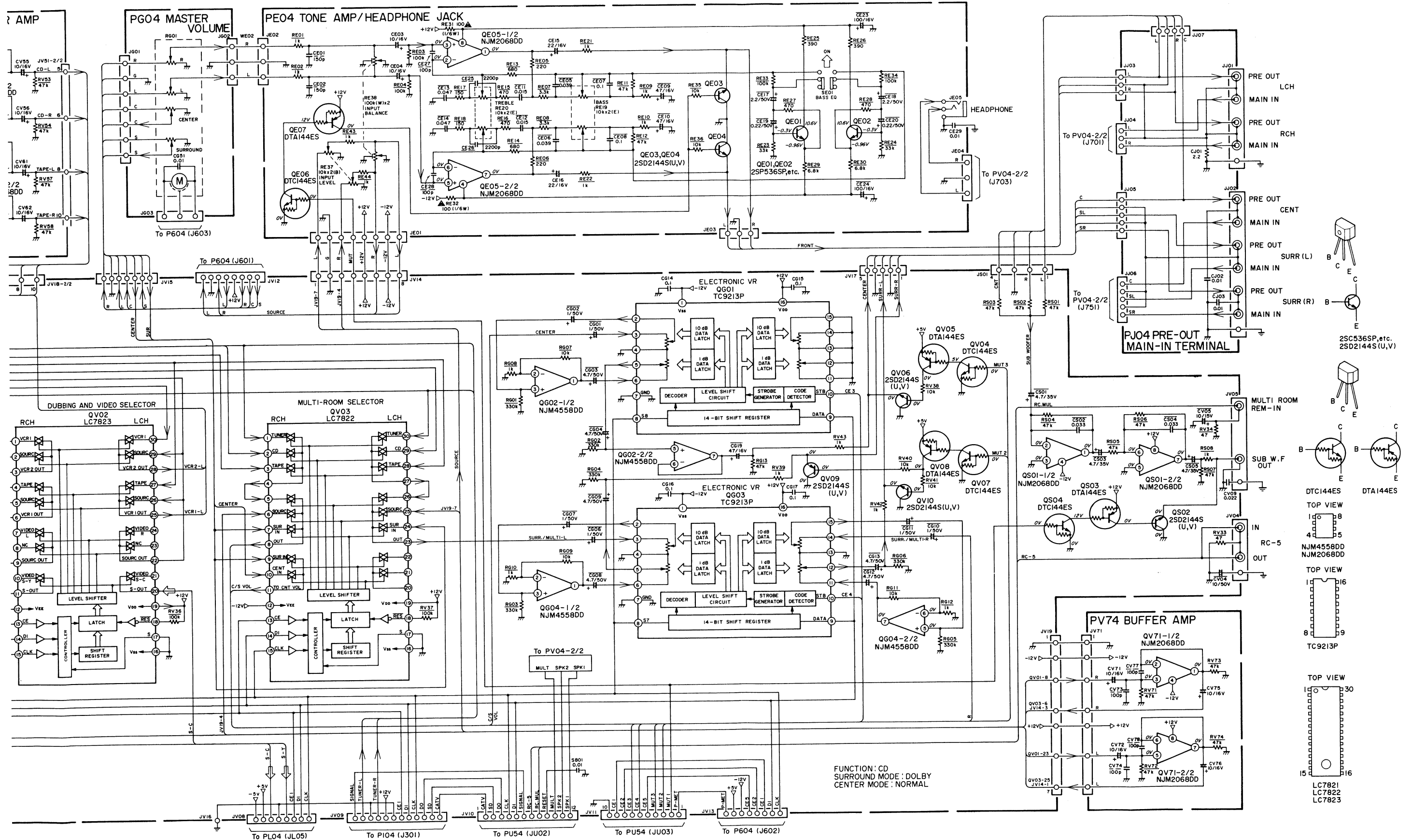

FUNCTION: CD
SURROUND MODE: DOLBY
CENTER MODE: NORMAL

Q401 QG02 QG01 QV01 QV03 QV04 QG03 QV02 QV04~QV10 QN08 QN07 Q801~Q804 QS02~QS04 QN04~QN06 QS01 QN71 QN72 QN09 QN51~QN53 Q751 QN54 Q714 Q710 Q706 Q708 Q712 QN01~QN03 Q704 Q702 Q715 Q713 Q709 Q703 Q701 Q705 Q707 Q711

PV04

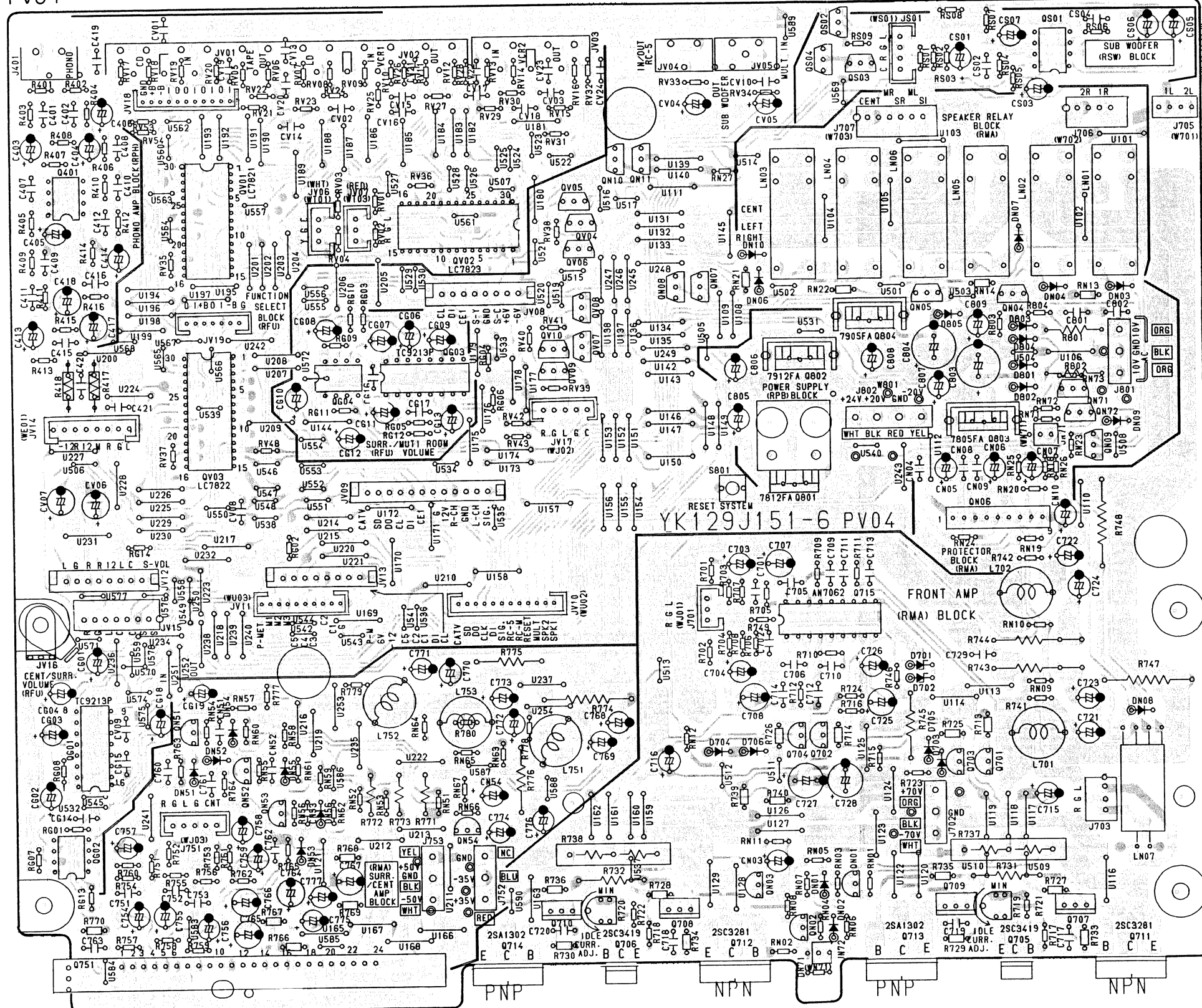

PE04

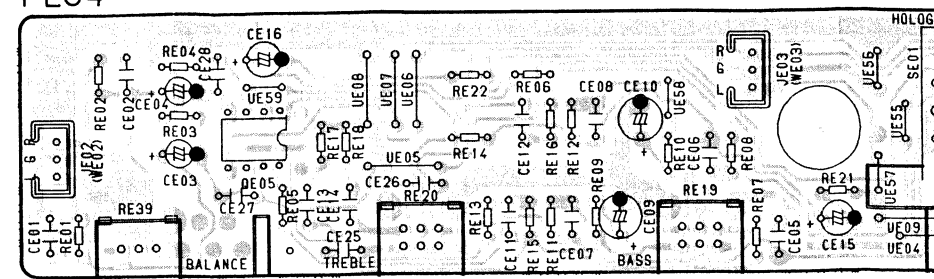

PJ04

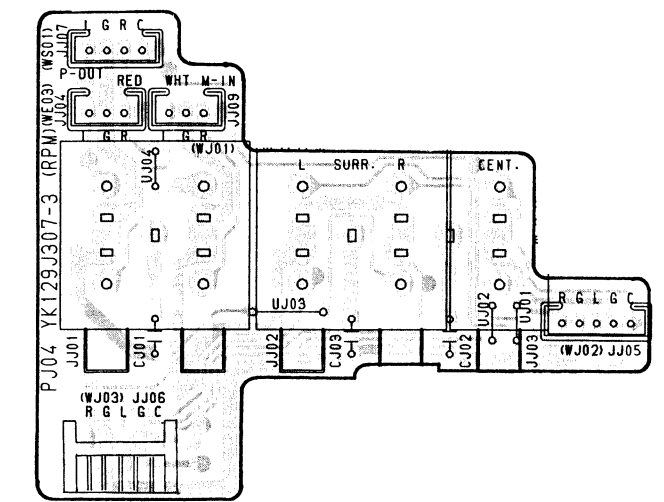

PV54

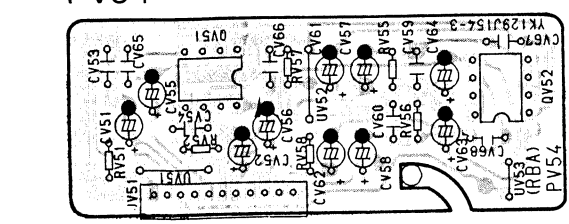

QV51

QV52

Q07 Q801~Q804 Q502~Q504 QN04~QN06 Q501 QN71 QN72 QN09
 '12 QN01~QN03 Q704 Q702 Q715 Q713 Q709 Q703 Q701 Q705 Q707 Q711

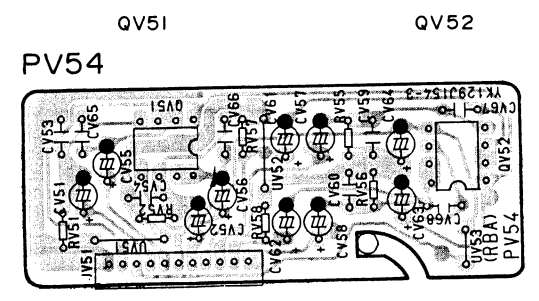
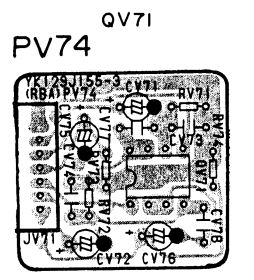
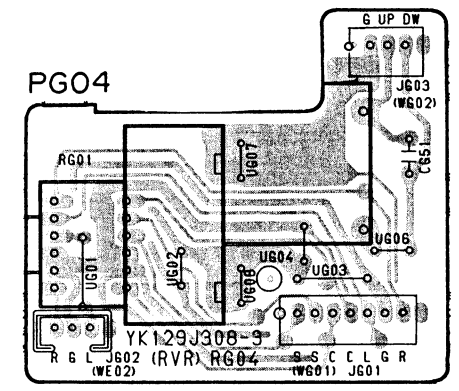
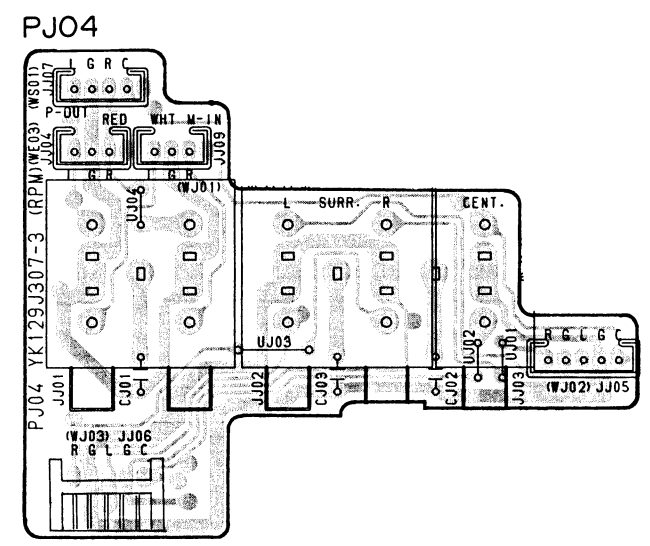
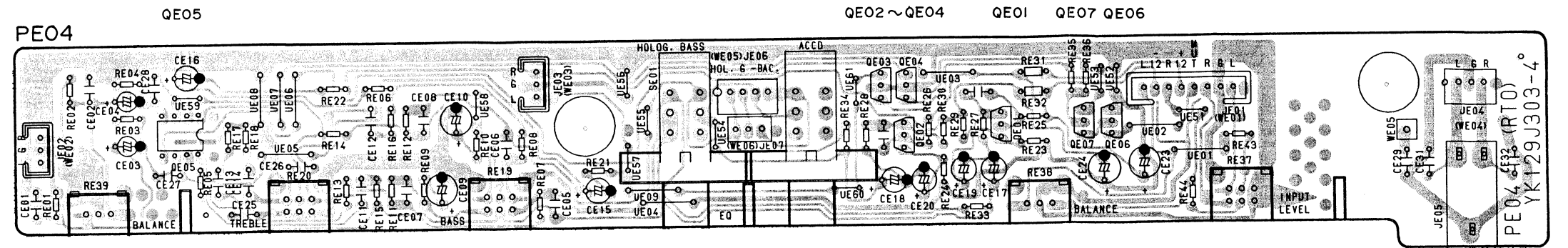
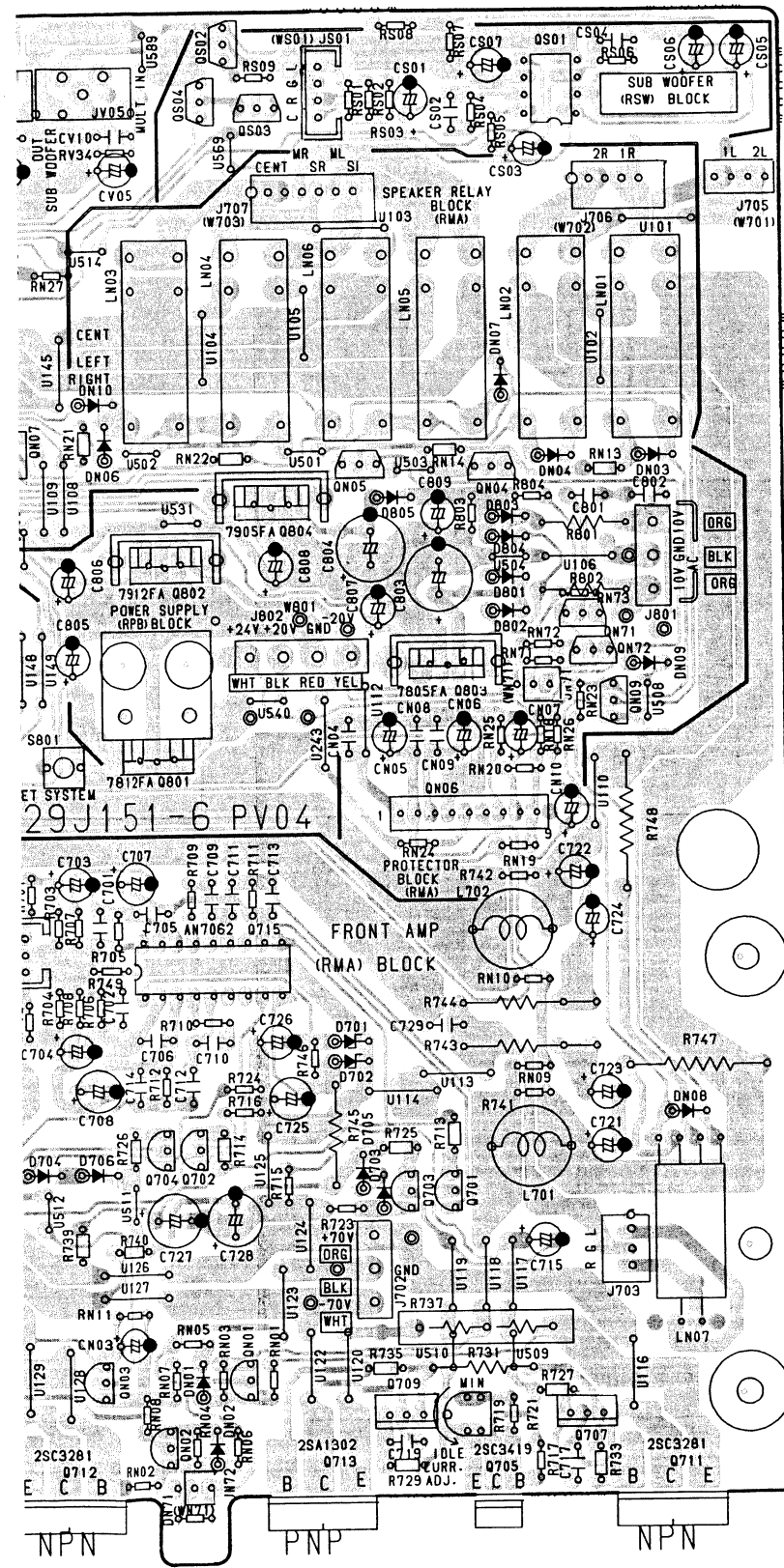

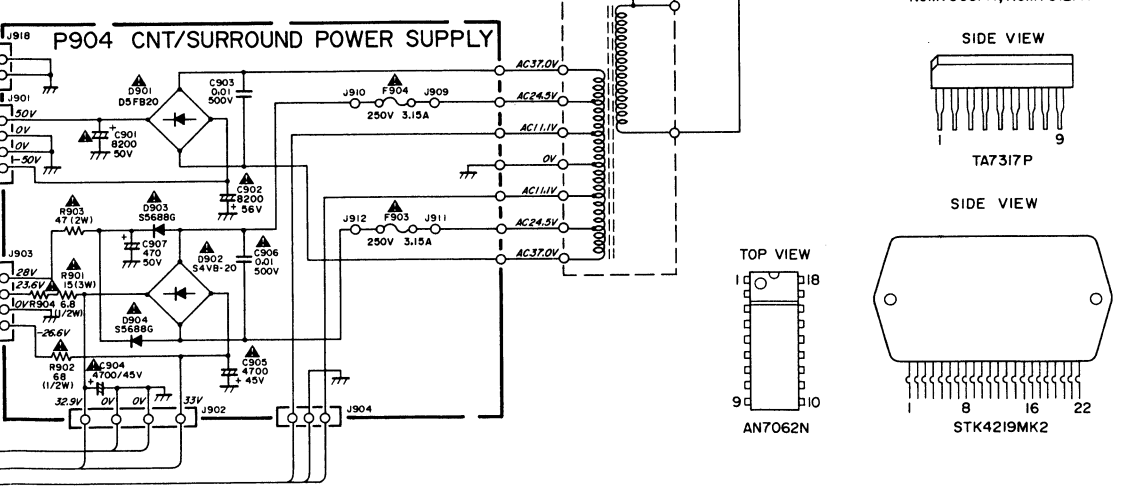
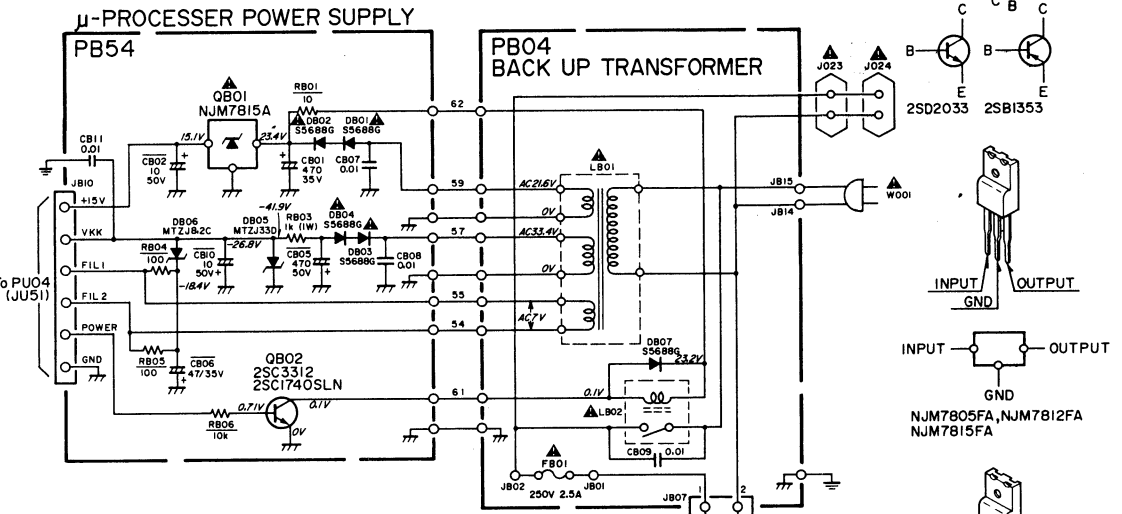
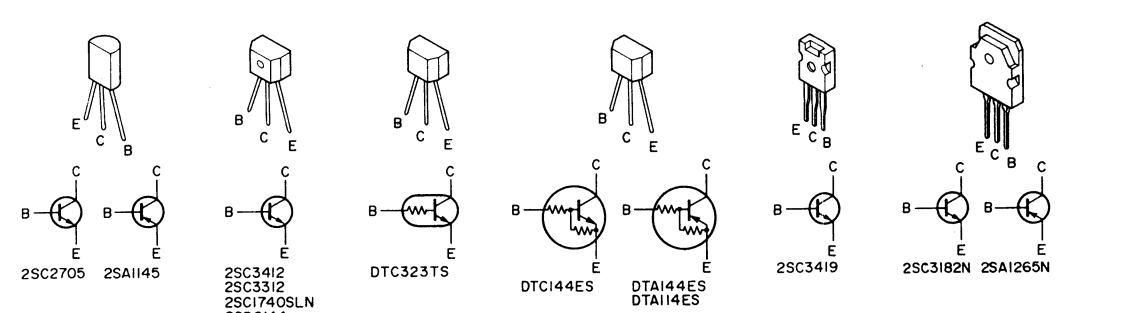
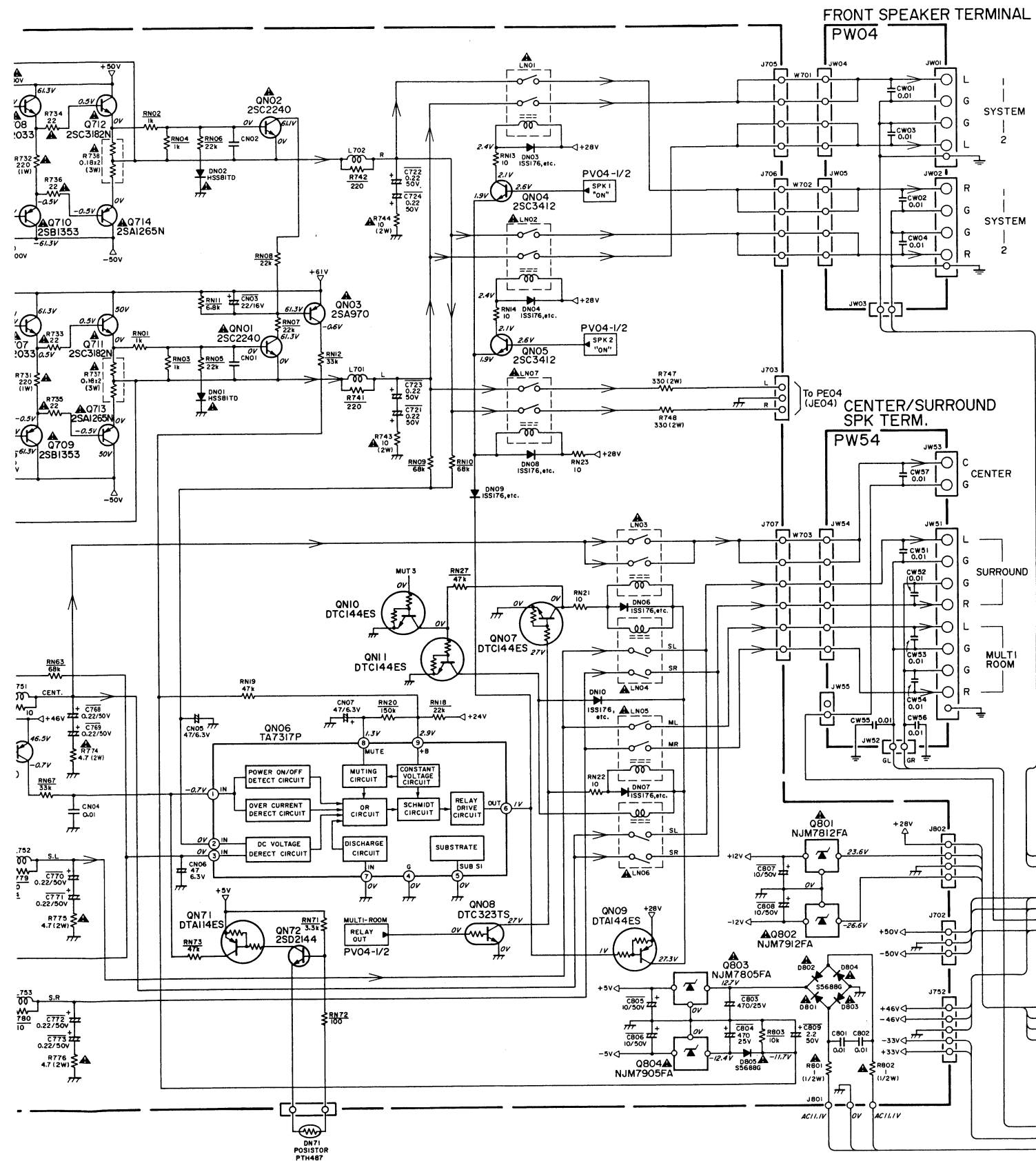

Q07 Q801~Q804 QS02~QS04 QN04~QN06 QS01 QN71 QN72 QN09
 *12 QN01~QN03 Q704 Q702 Q715 Q713 Q709 Q703 Q701 Q705 Q707 Q711

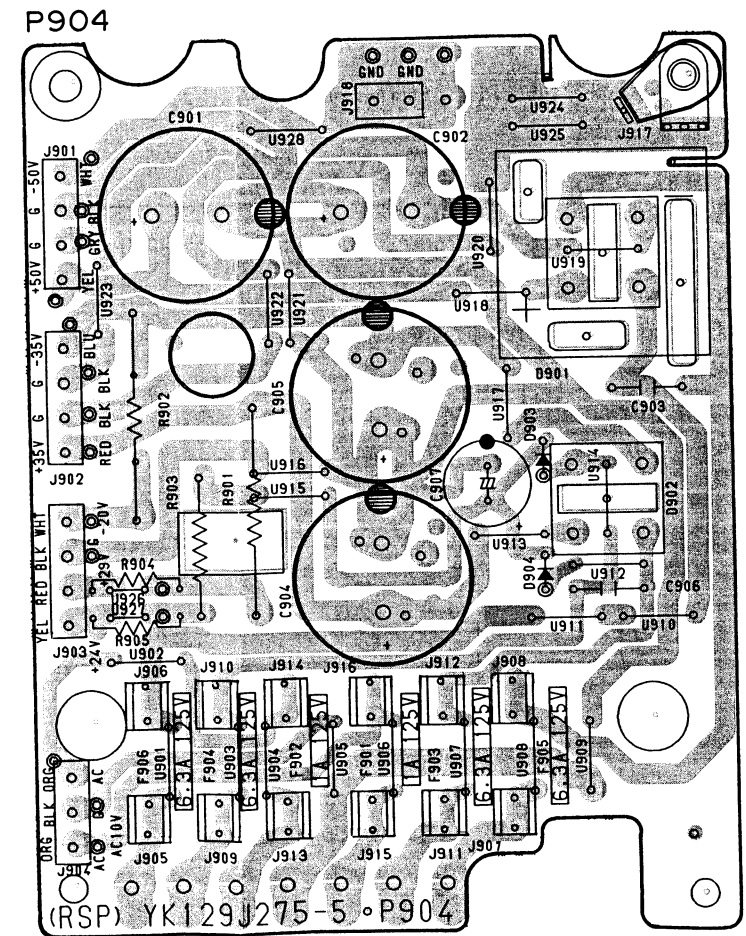
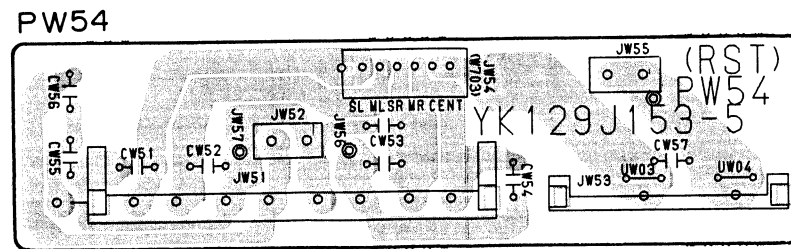
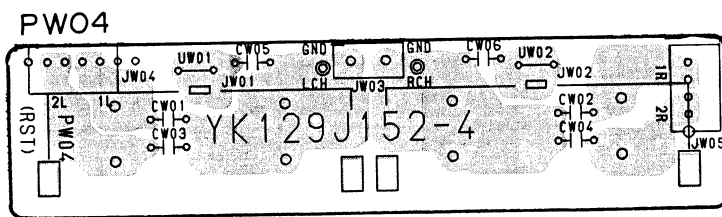
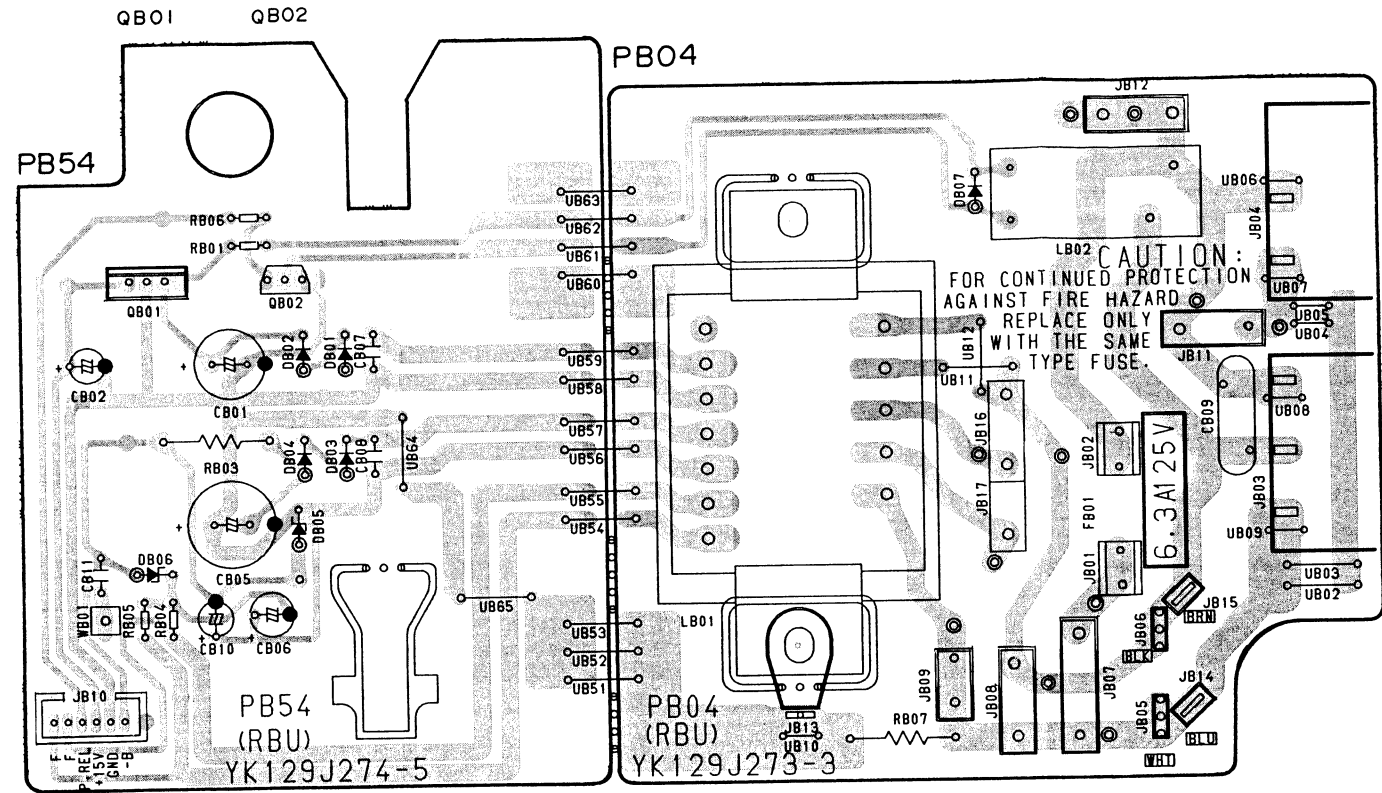
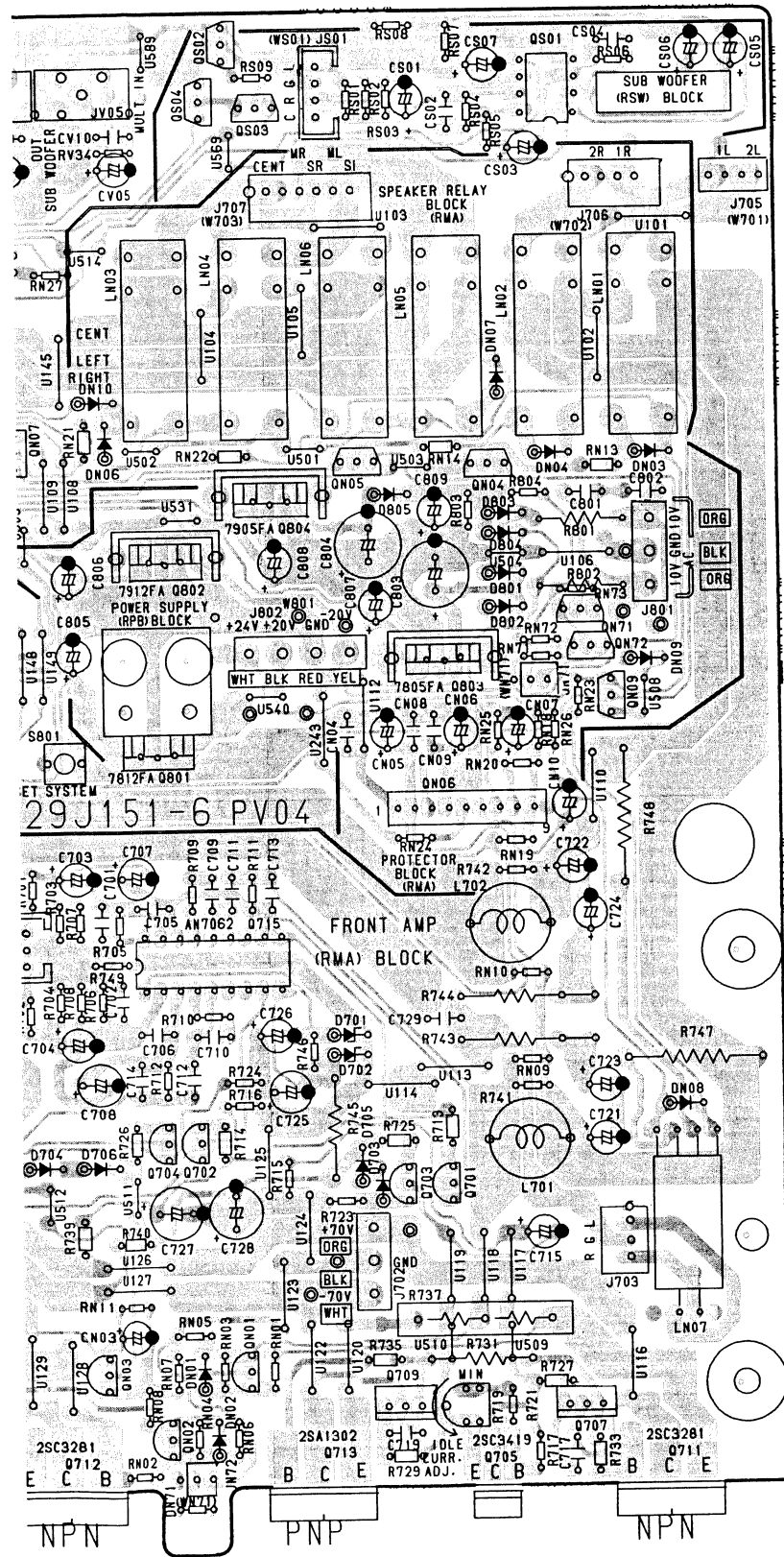

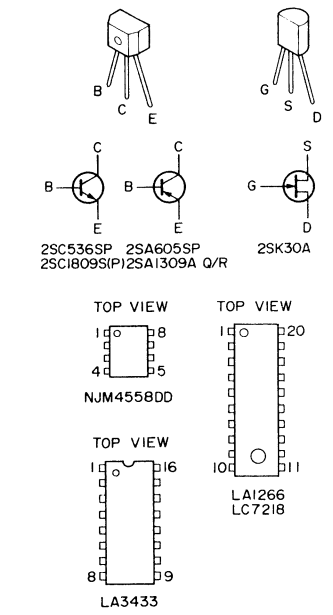
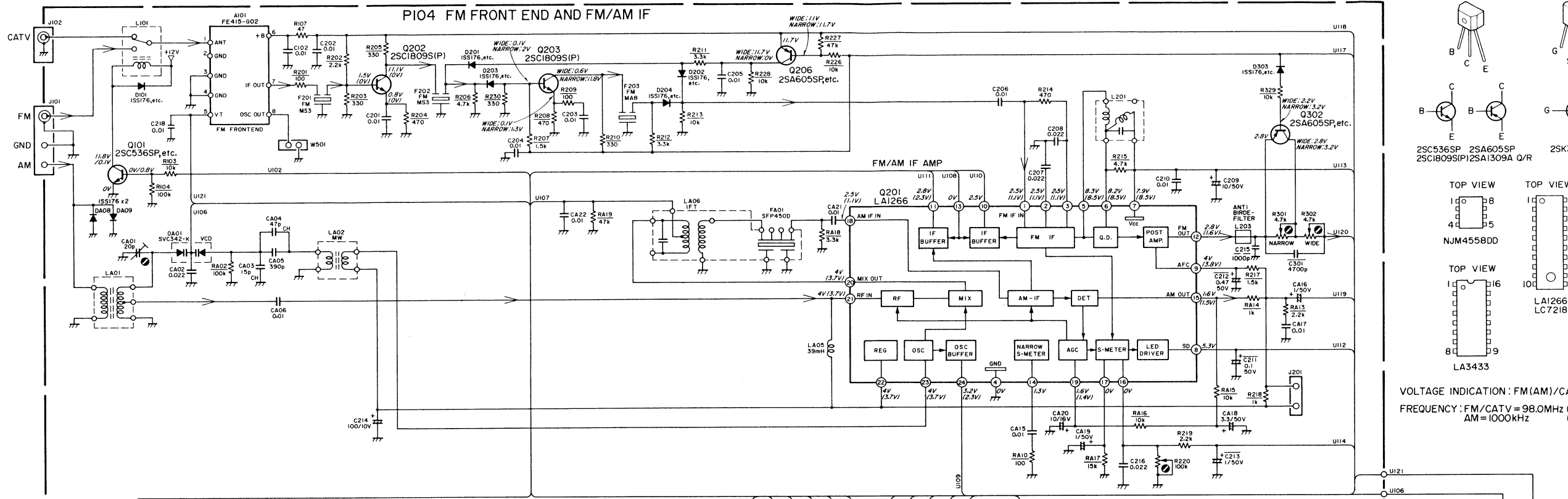

VOLTAGE INDICATION : FM (AM)/CATV
 FREQUENCY : FM/CATV = 98.0MHz (NO SIGNAL)
 AM = 1000kHz (NO SIGNAL)

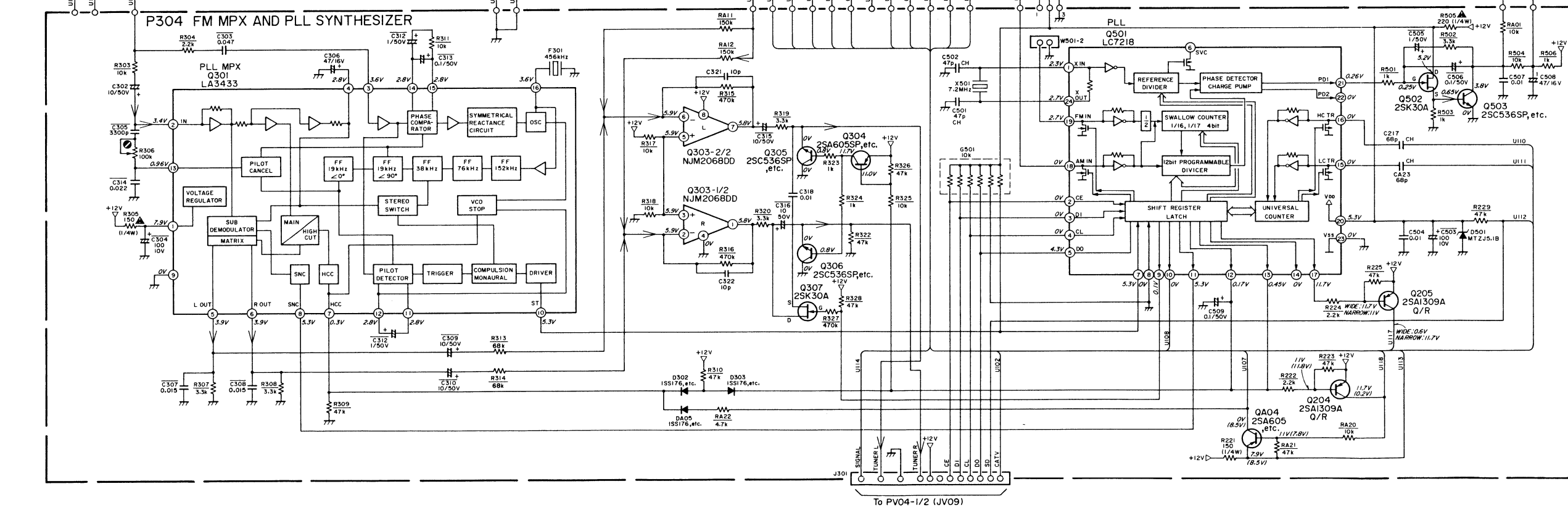
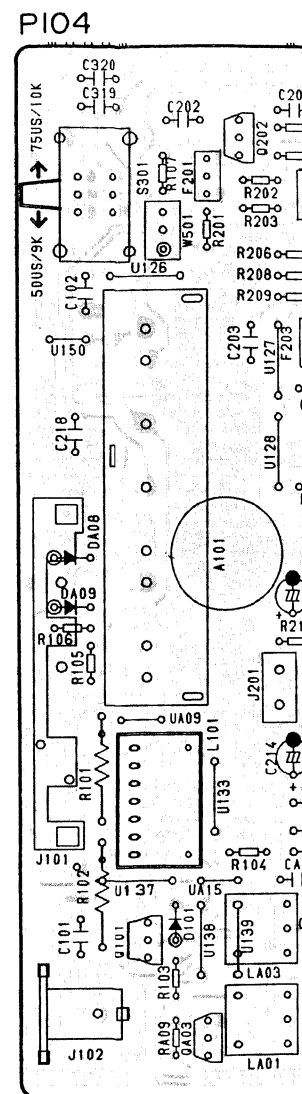

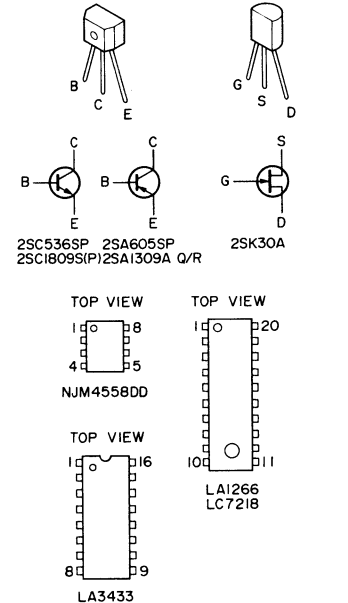
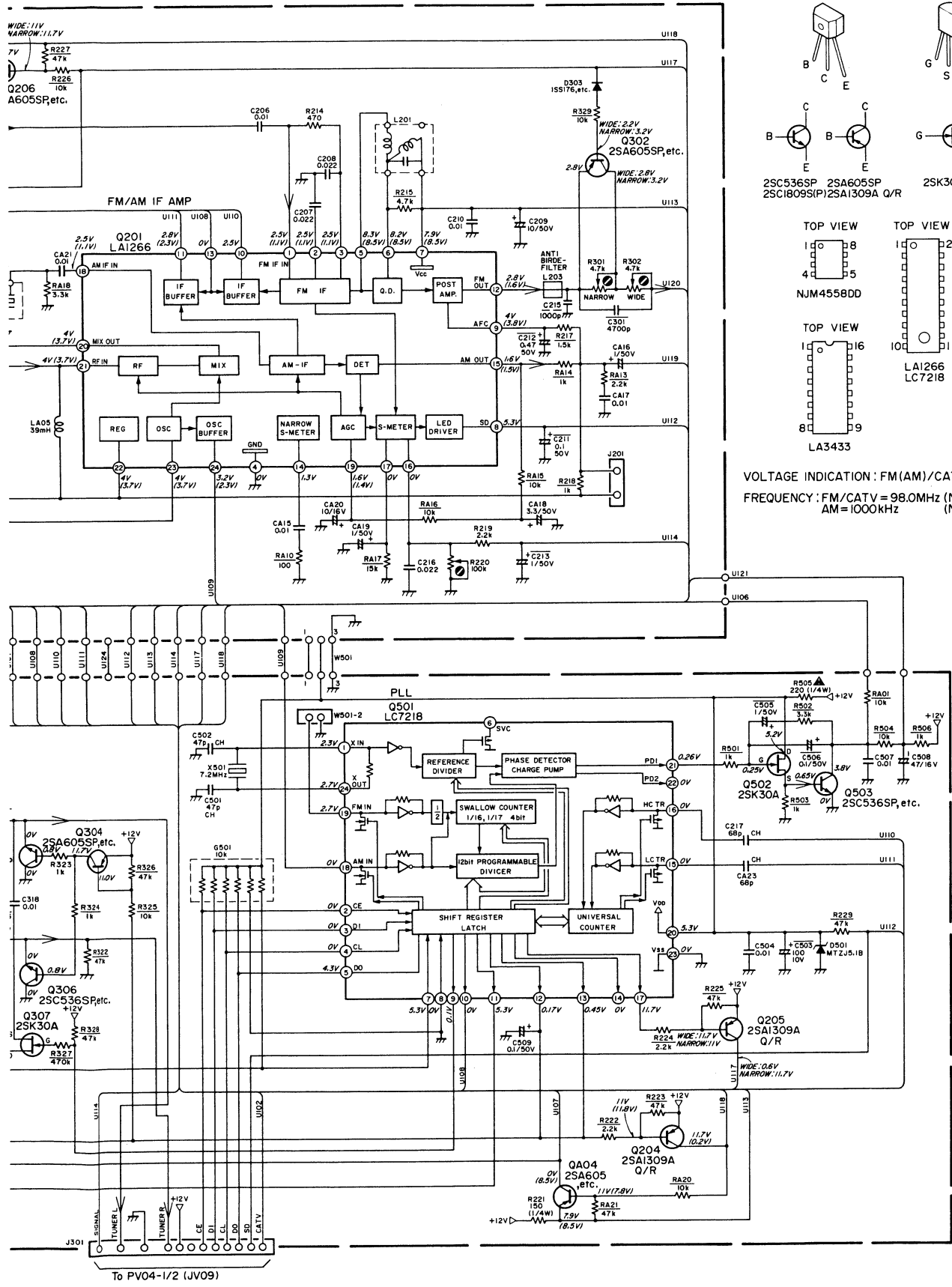

VOLTAGE INDICATION: FM(AM)/CATV
 FREQUENCY: FM/CATV = 98.0MHz (NO SIGNAL)
 AM = 1000kHz

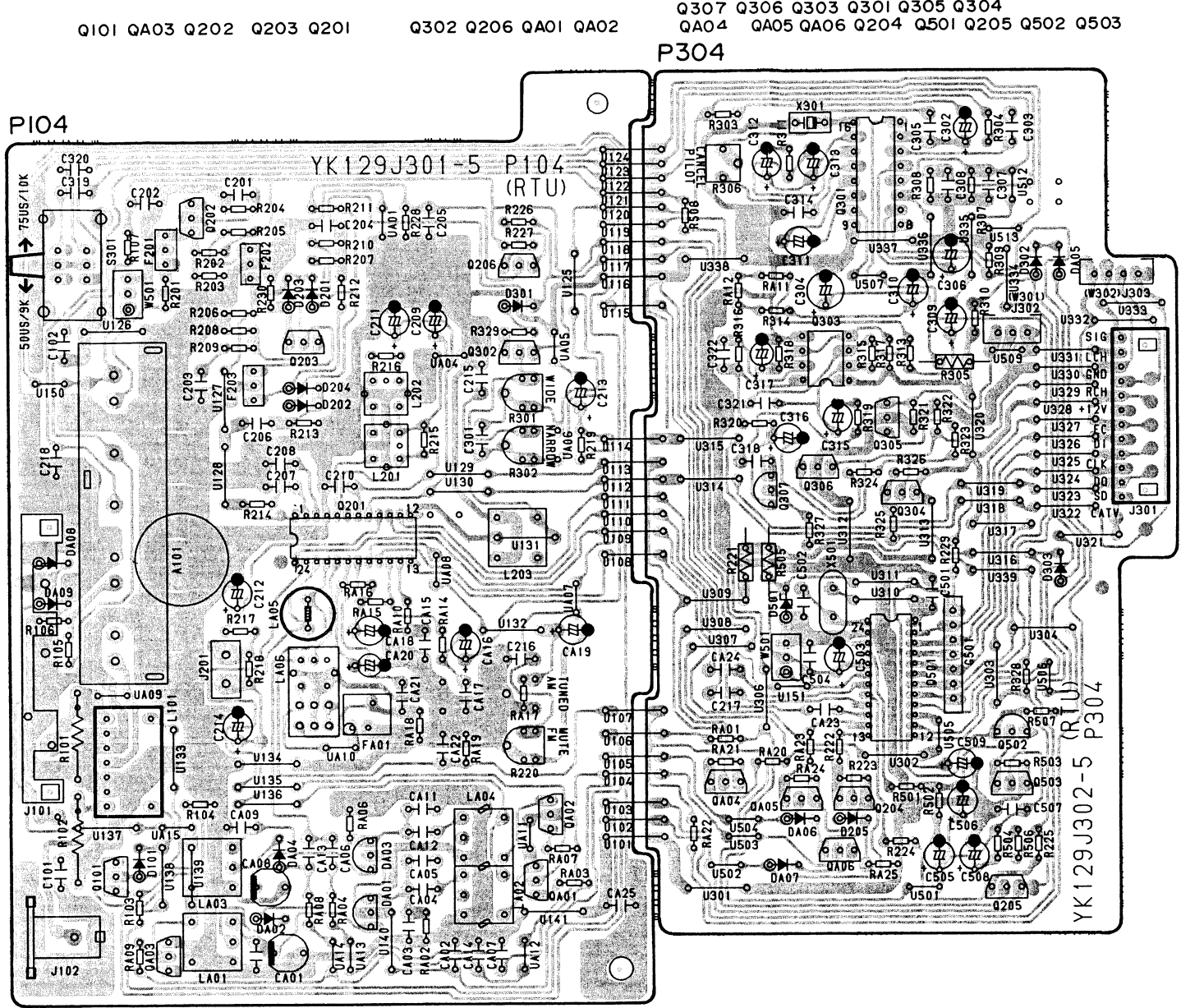

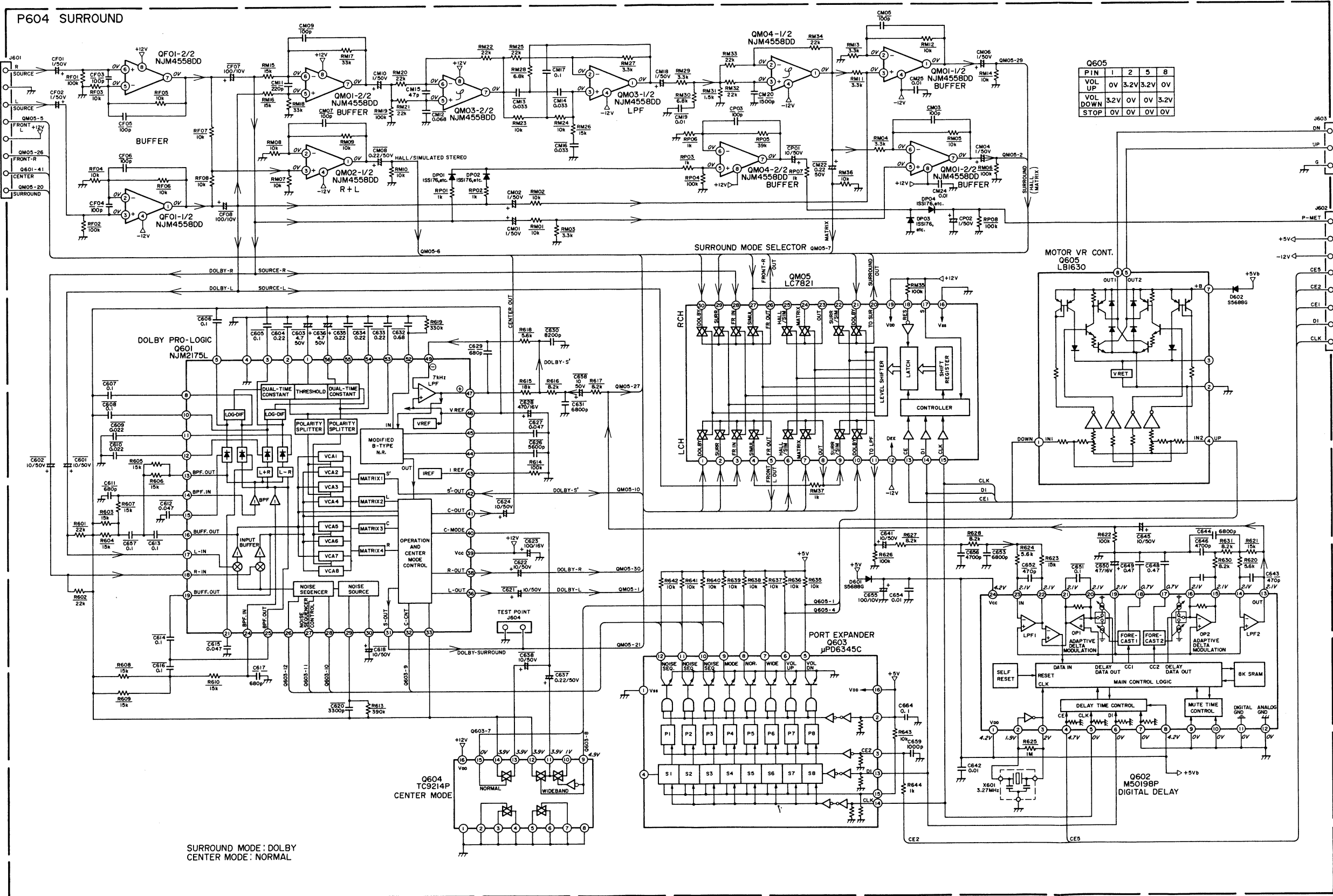

To PV04-1/2 (JV12)

To PG04 (JG03)

To PV04-1/2 (JV13)

SURROUND MODE: DOLBY
CENTER MODE: NORMAL

PIN	1	2	5	8
VOL UP	0V	3.2V	3.2V	0V
VOL DOWN	3.2V	0V	0V	3.2V
STOP	0V	0V	0V	0V

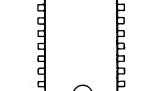
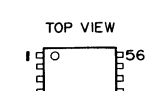
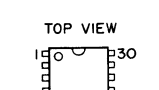
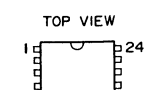
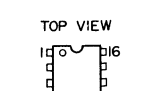
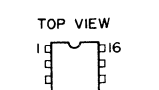
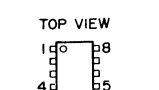

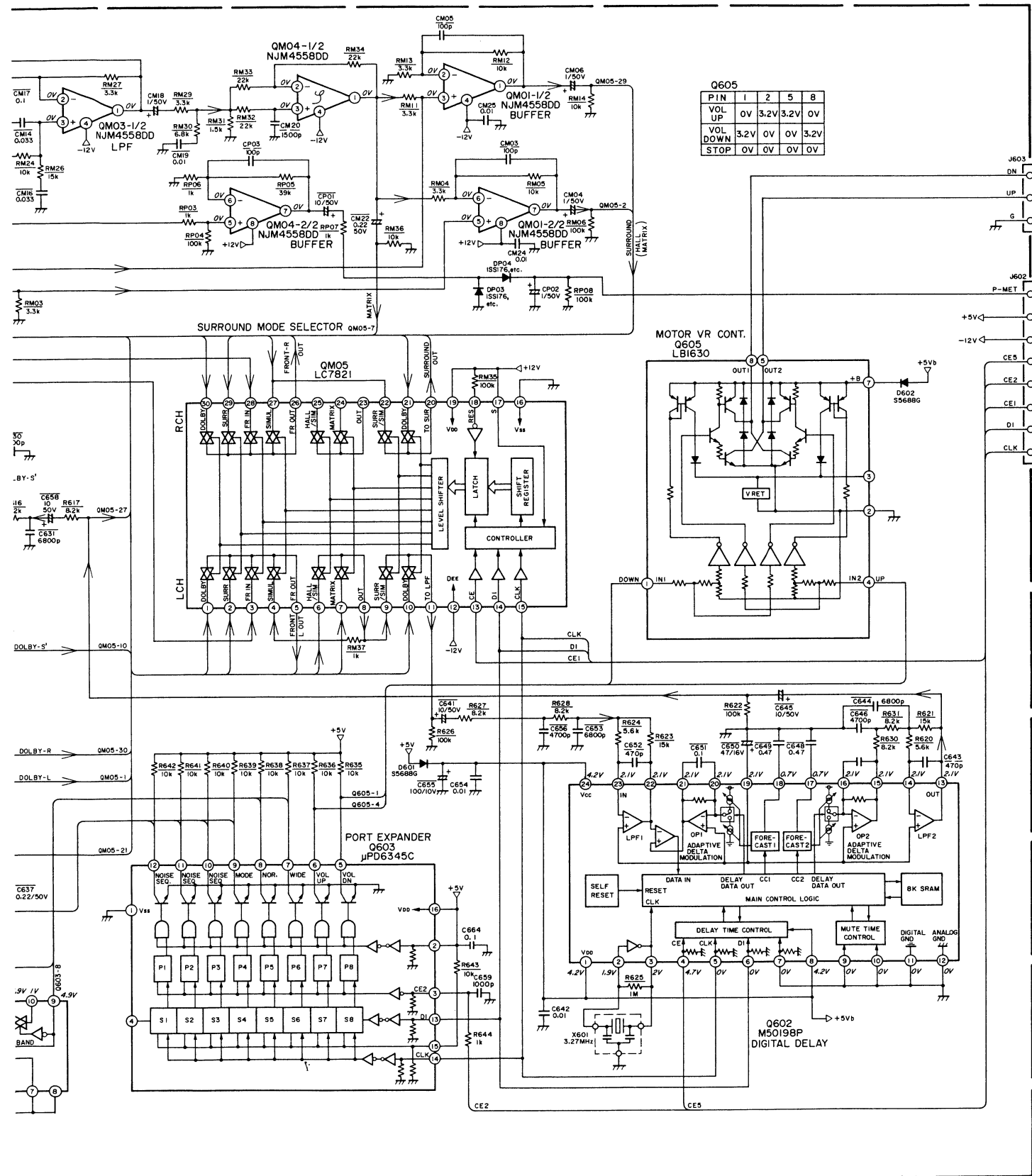

PIN	1	2	5	8
VOL UP	0V	3.2V	3.2V	0V
VOL DOWN	3.2V	0V	0V	3.2V
STOP	0V	0V	0V	0V

TOP VIEW



TOP VIEW

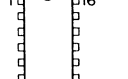

TOP VIEW

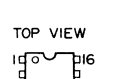

TOP VIEW

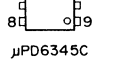

TOP VIEW

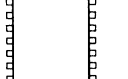

TOP VIEW

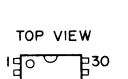

TOP VIEW

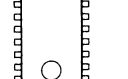

TOP VIEW

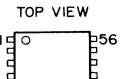

Q604

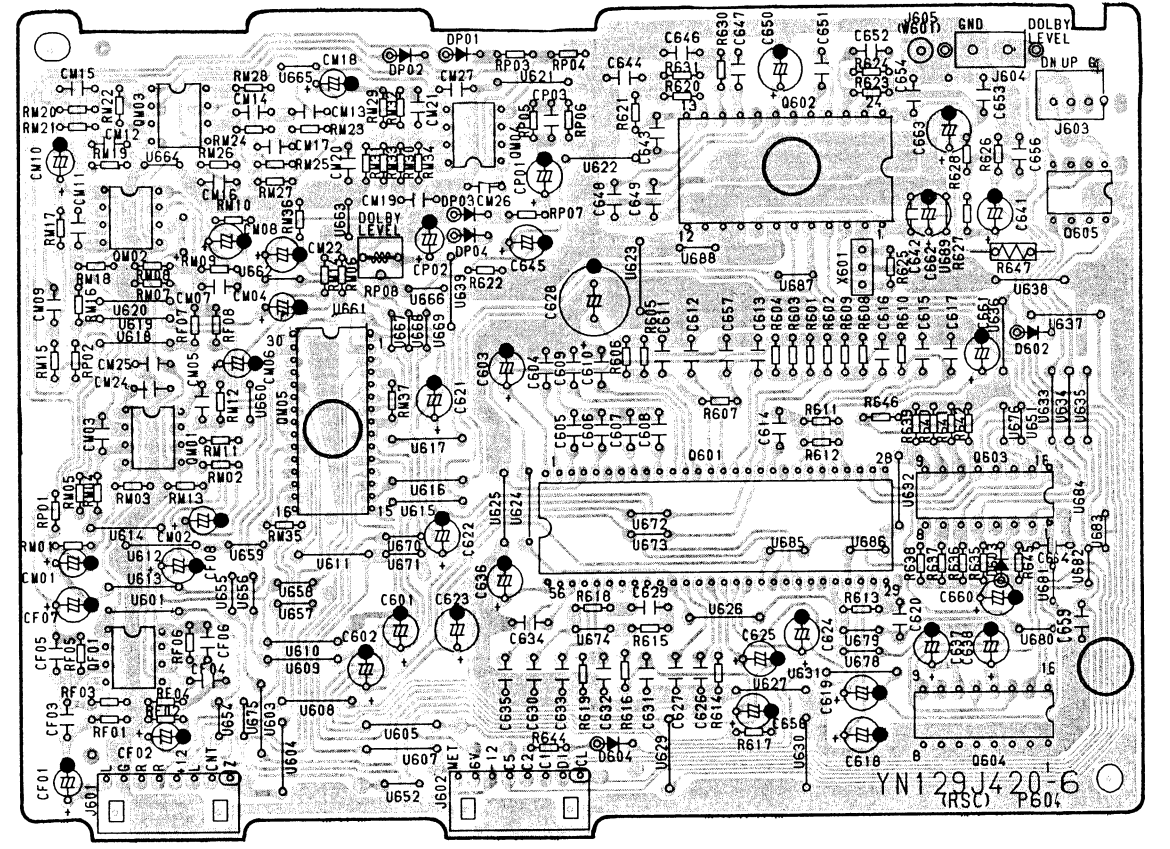

QF01 QM01~QM03 QM05 QM04 Q601 Q602 Q603 Q604 Q605

PU04 μ -PROCESSOR AND SWITCH

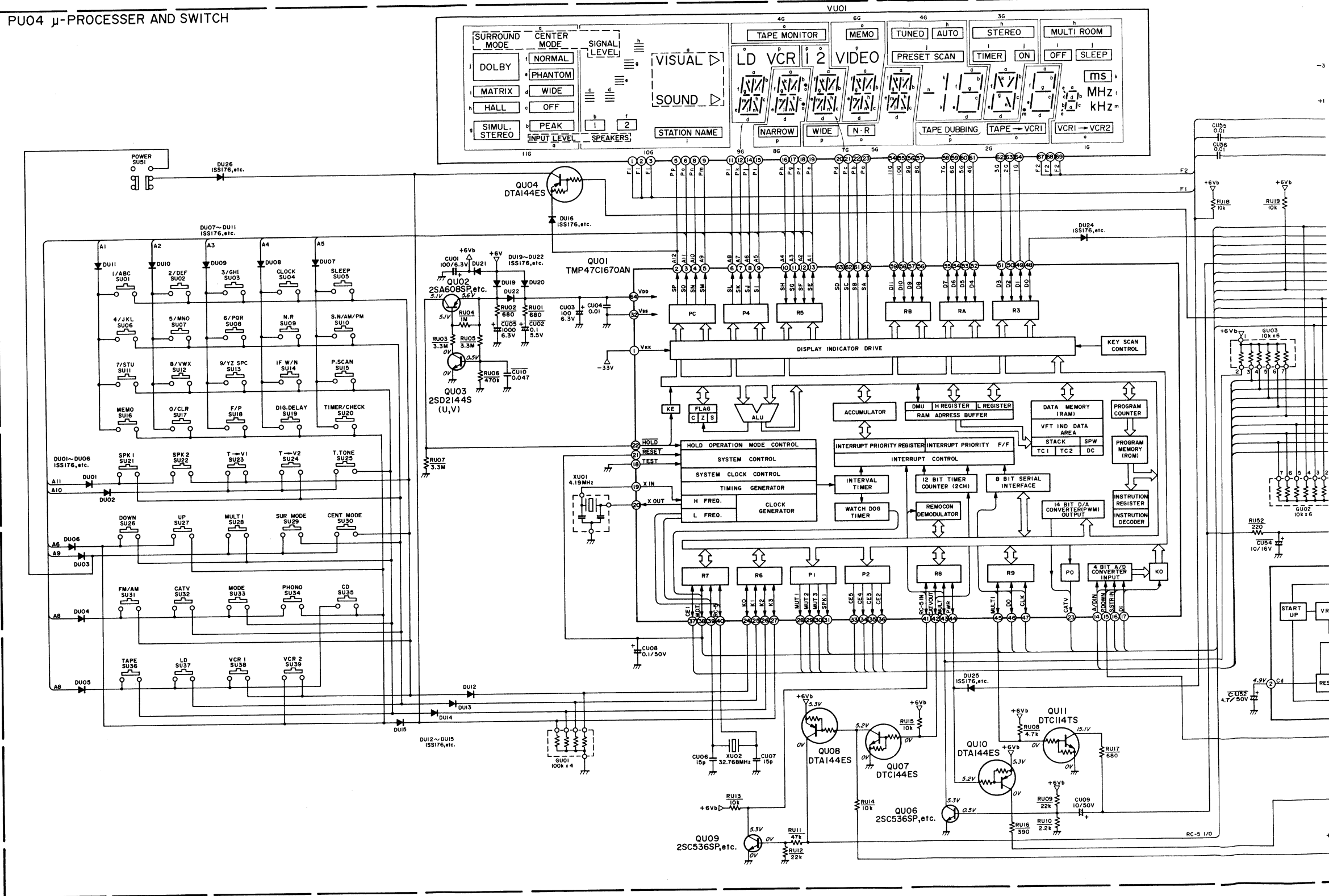

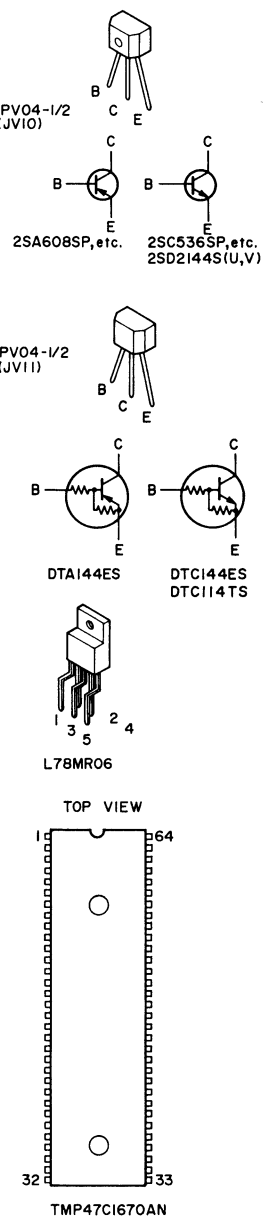
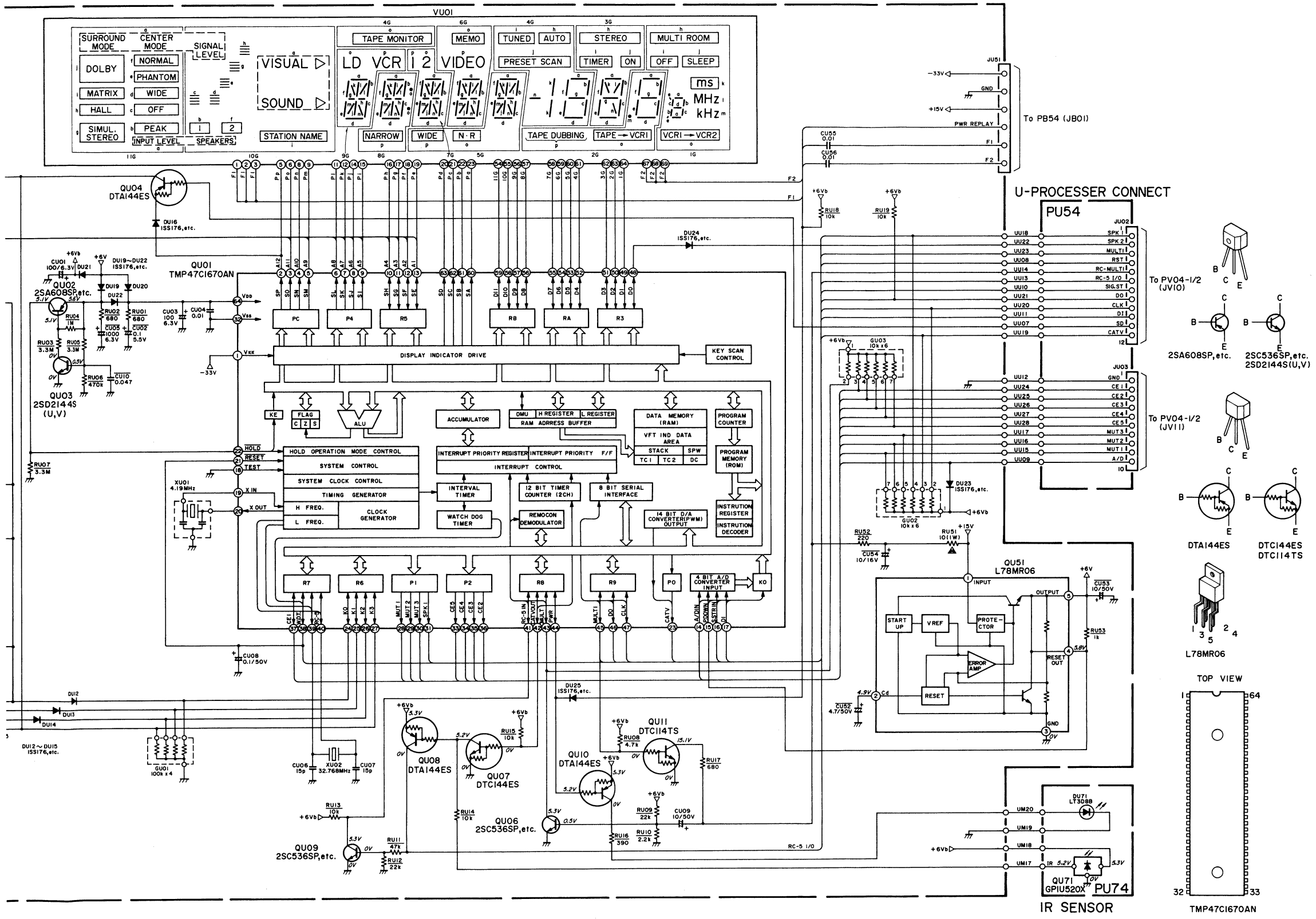

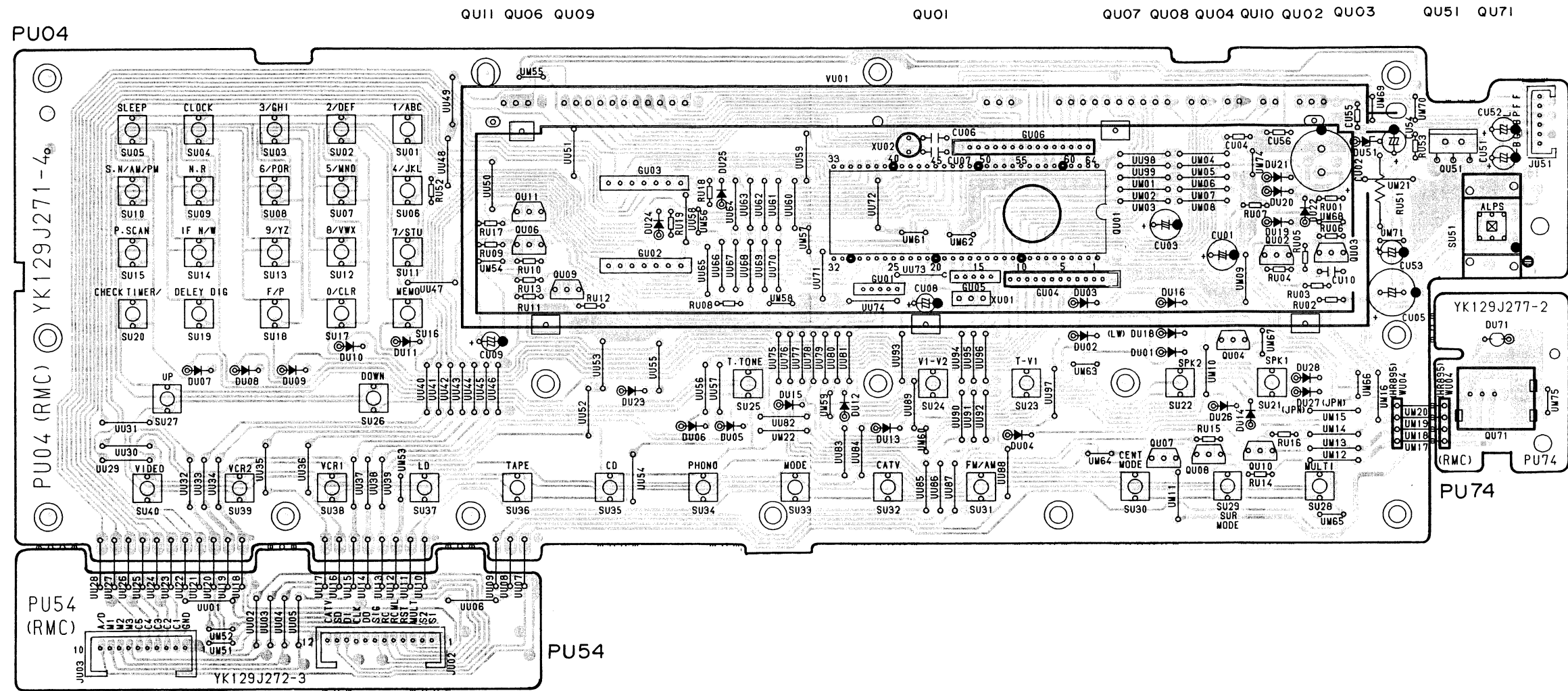

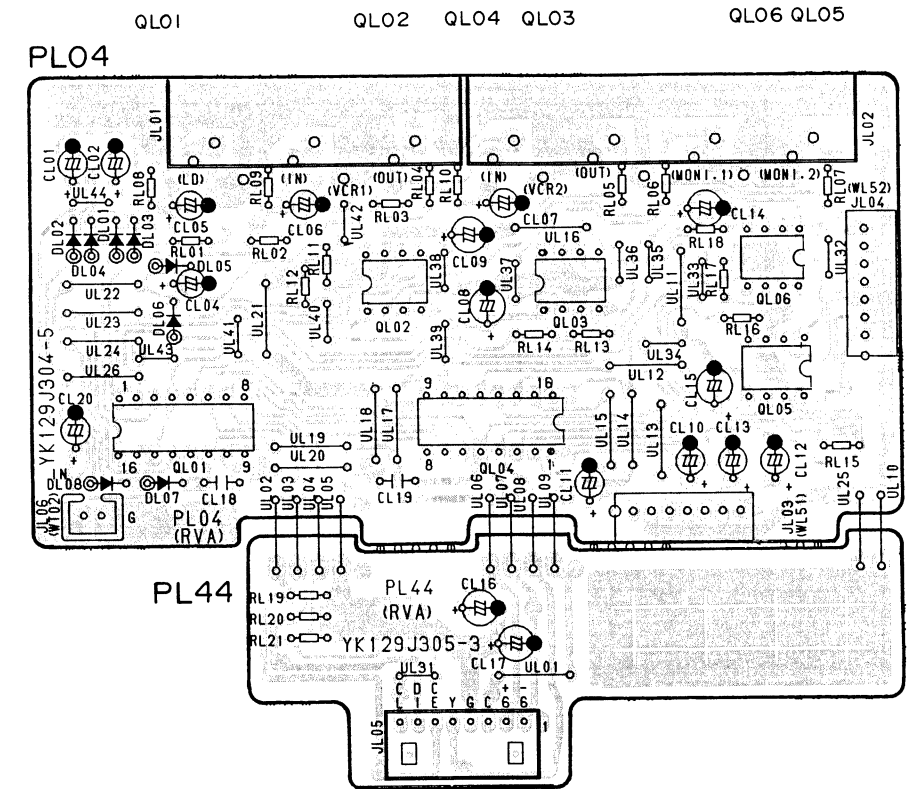
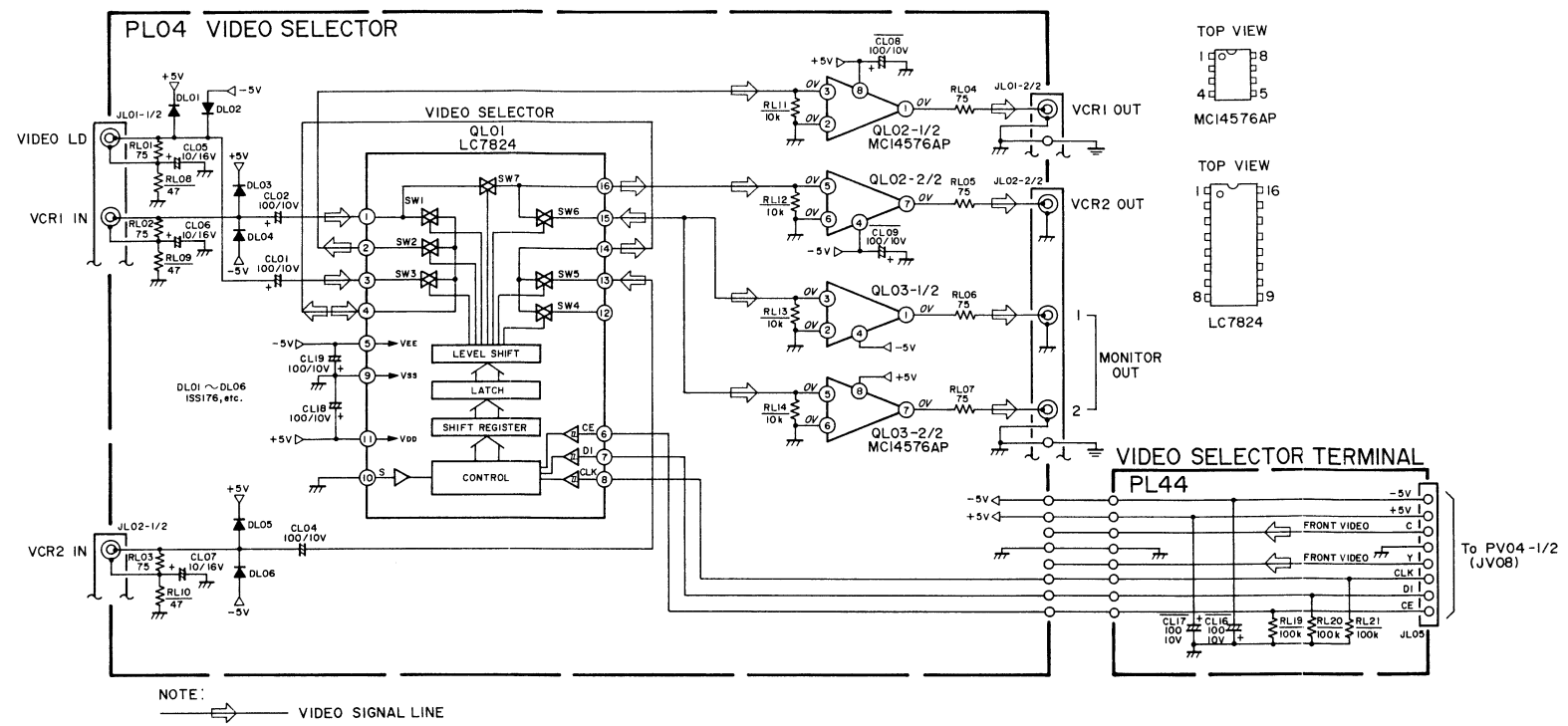

4. EXPLODED VIEW AND PARTS LIST

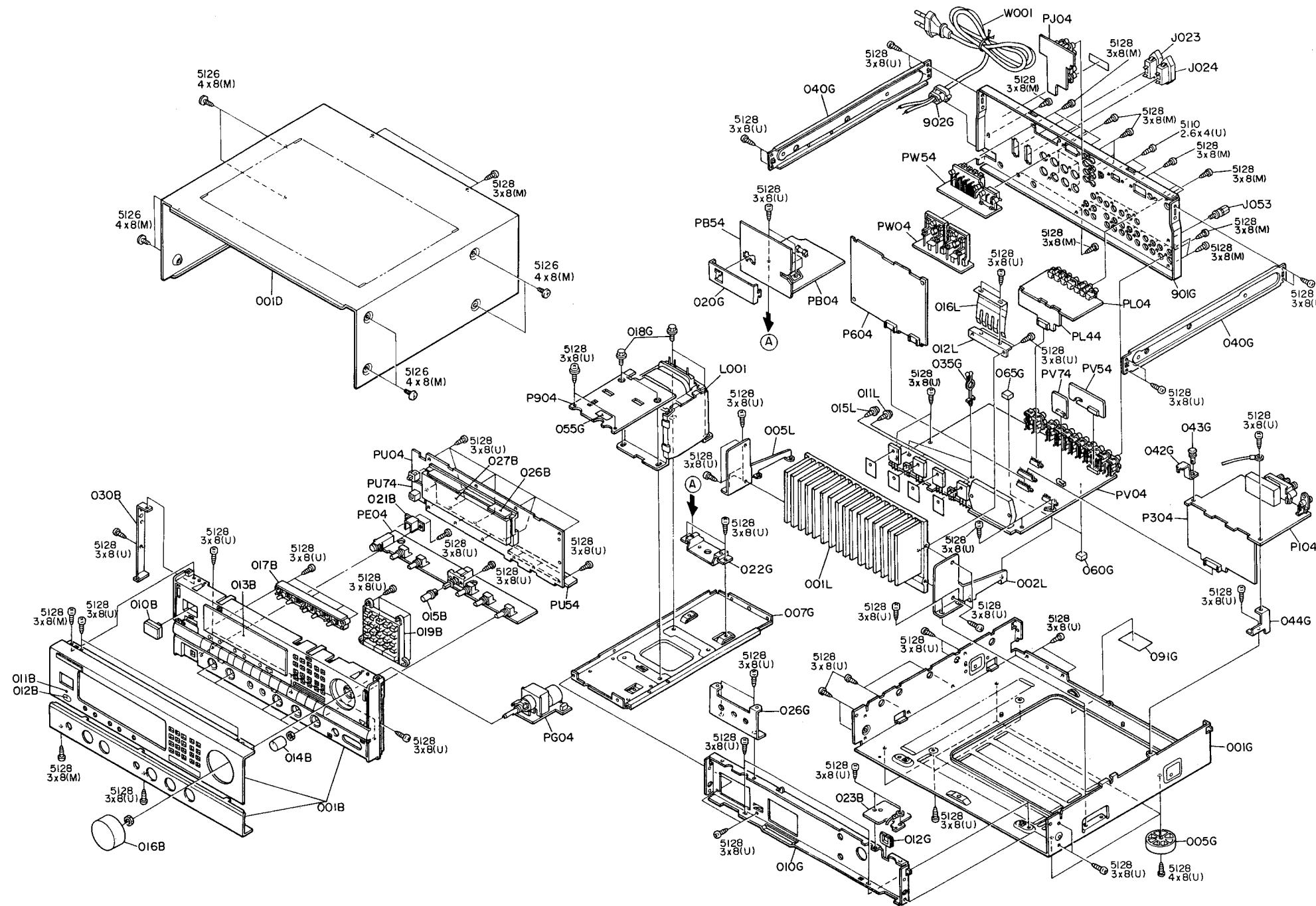

REF. DESIG.	PART NO.	DESCRIPTION
001B	4822 464 70617	Front Panel Assembly
010B	4822 410 60194	Button, Power
013B	4822 450 62091	Window, FL
014B	4822 413 31551	Knob, Rotary
015B	4822 410 61754	Button, Push
016B	4822 413 41679	Knob, Volume
017B	4822 410 62707	Button, Spk/Tape/Test Tone
019B	4822 410 62706	Button, 10 Key
026B	4822 256 91361	Holder, FL
027B	4822 459 10942	Sticker, FL
005G	4822 462 41383	Leg
902G	4822 532 60948	Bushing, AC Cord
011L	4822 502 13851	B.T. Screw (W/W) M3 x 15
015L	4822 502 13851	B.T. Screw (W/W) M3 x 15
016L	4822 492 71384	Leaf Spring, Power Pack
▲ J023	4822 267 30597	Jack, AC Outlet
▲ J024	4822 267 30597	Jack, AC Outlet
▲ L001	4822 146 21739	Power Transformer
Z001	4822 303 30314	EXT. Antenna Plug, Ant Adapter
Z002	4822 264 30265	Ant Coil, Loop
Z003	4822 157 63083	Unit K, RC-82SR2
Z004	4822 218 10516	
001T	4822 736 21764	User Manual

NOTE ON SAFETY :
 Symbol ▲ Fire or electrical shock hazard. Only original parts should be used to replace any part marked with symbol ▲. Any other component substitution (other than original type), may increase risk of fire or electrical shock hazard.

5. TEST EQUIPMENT REQUIRED FOR SERVICING

This table lists the test equipment required for servicing.

Item	Use
Distortion Analyzer	Distortion measurements
Audio Oscillator	Sinewave and squarewave signal source
ACVTVM	Voltage measurements (AC)
Oscilloscope	Waveform analysis and trouble shooting and ASO alignment
Circuit Tester	Trouble Shooting
DCVTVM	Voltage measurements (DC)
AC Wattmeter	Monitors primary power to amplifier
Line Voltmeter	Monitors potential of primary power to amplifier
Variable Autotransformer	Adjust level of primary power to amplifier
Shorting Plug	Shorts amplifier input to eliminate noise pickup

6. IDLING CURRENT ADJUSTMENT

- Before switching the power ON, set the Master Volume control to the minimum position and the Balance and Tone controls to the center positions. Then, rotate the semi-fixed resistors R721 (L CH) and R722 (R CH) on the PC board PV04 fully clockwise.
- Connect a digital voltmeter, set for the DC voltage input to the pertinent test points (the marked ones of R737-R738) on the PC board PV04. (Positive: Left side, Negative: Right side)
- After the completion of the above setup. Switch the power ON and adjust the semi-fixed resistors R721 (L CH) and R722 (R CH) on the PC board PV04 according to the reading of the digital voltmeter. The setting values are 3 ~ 4 mV (8.3 ~ 11.1 mA) of the both channels.

Please refer to the table below.

Power ON	
20 sec later	1 mV
1 min later	2 mV
More than 5 min	3.0 ~ 4.0 mV

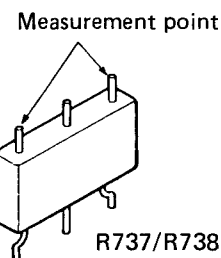

7. DOLBY PEAK INDICATOR LIGHTING LEVEL CHECK

- Generate 1 kHz L~R signals from the audio SG and input them to the CD jacks of the set.
- Set the surround mode of the set to DOLBY. The center mode can be any mode.
- Connect an AC voltmeter to test point: J604 on the Surround board (P604), and set the voltmeter range to 2V.
- Adjust the attenuator of the SG or the INPUT LEVEL control of the set so that the "PEAK" segments of the FL indicator lights.
- Attenuate the input so that the "PEAK" segments do not light any more, then increase the input again and check that the "PEAK" indicator segments light up at between 1.1 and 1.3V.

8. SERVICE PROGRAM

1. T.R POINT ME (tracking point memory) mode.

From power OFF (stand-by mode), when the POWER switch is pressed ON while pressing the MEMO key, the T.R POINT ME mode is called.

Frequencies to be memorized are as follows.

	P1	P2	P3	P4	P5	P6	P7	P8
FM	90.0 MHz	98.0 MHz	106.0 MHz	87.5 MHz				
AM					603 kHz	999 kHz	1404 kHz	531 kHz

	P9	P10	P11	P12-P30
FM				
AM	531 kHz	531 kHz	531 kHz	531 kHz

2. FL segment check mode.

From power OFF (stand-by mode), when the POWER switch is pressed ON while pressing the UP and MEMO keys simultaneously, the FL segment check mode is called.

- When the test mode is entered, microprocessor's MUTE OUT becomes "HIGH" to apply muting to the unit itself. No change occurs in any setting.
- All segments are alight for 5 seconds.
- The segment check mode can be canceled by setting the POWER switch to OFF.

9. TUNER ALIGNMENT PROCEDURES

- When you adjust a set, use a signal generator with a counter with which you can correctly read frequencies, or connect a counter to a signal generator with a counter terminal for both AM and FM.

- As a rule, use a band-pass filter (B.P.F 200-15 kHz) designated by IHF in adjustment and measurement of FM.

Be sure to use a filter especially in adjustment of STEREO DISTORTION and SEPARATION. (Attenuation at 19 kHz is to be 30 dB at least.)

- The controller (QU01) used in this set has a function to preset and memorize the frequencies of guard and tracking point to be used in adjustment and measurement.

Caution:

Alignment of FM needs to set the IF BAND SWITCH to "WIDE" position if any other instruction does not require.

- Set to T.R point ME mode of the service program, after that, needs POWER OFF and POWER ON again. (P1) to (P7) in the Digital Readout Frequency Setting column shows preset numbers for the above mode. Before alignment, connect a dummy resistor of 47 kohms to the tape out terminal.

4. FM Alignment Procedures

(Function switch at "FM" position and MODE switch at "MONAURAL" position)

• FM RF Alignment

IF BAND switch at "WIDE" position

Step	Signal Source Connection	Signal Frequency	Indicator Connection	Digital Readout Frequency Setting	Adjust
1	FM signal generator to FM antenna terminal. Adjust the RF signal output so that slight noise occurs at the upper and lower sides of the output waveform.	98.0 MHz	AC VTVM to L- or R-channel output (TAPE OUT)	98.0 MHz (P2)	Front end IFT for maximum output and minimum distortion.
2	FM signal generator 500 μV output to FM antenna terminal (75-ohm). Modulation 1 kHz 53.3% (40 kHz)	98.0 MHz	Distortion meter to L- or R-channel output (TAPE OUT)	98.0 MHz (P2)	L201 core fore minimum distortion.

• FM IF Alignment

(Function switch at "FM" position and MODE switch at "AUTO STEREO" position)

IF BAND switch at "WIDE" position

Step	Signal Source Connection	Signal Frequency	Indicator Connection	Digital Readout Frequency Setting	Adjust
1	FM signal generator 500 μV output modulated by MPX signal generator to FM antenna terminal (75-ohm). Modulation level: IHF 53.3% (40 kHz) +8% pilot dev.	Stereo L-channel (1,000 Hz)	VTVM to L-channel output (TAPE OUT L channel)	98.0 MHz (P2)	Front end IFT for minimum distortion.
2		Stereo R-channel (1,000 Hz)	VTVM to R-channel output (TAPE OUT R channel)		

● **Muting Level Alignment**

(Function switch at "FM" position and MODE switch at "AUTO STEREO" position)

Step	Signal Source Connection	Signal Frequency	Indicator Connection	Digital Readout Frequency Setting	Adjust
1	FM signal generator 6.3 μ V output to FM antenna terminal (75-ohm)	98.0 MHz		98.0 MHz (P2)	R220 to a point at which shows "tuned."

● **Multiplex Alignment**

(Function switch at "FM" position and MODE switch at "AUTO STEREO" position)

Step	Signal Source Connection	Signal Frequency	Indicator Connection	Digital Readout Frequency Setting	Adjust
1	FM signal generator 500 μ V output modulated by MPX signal generator to FM antenna terminal (75-ohm) Modulation level: 1HF 53.3% (40 kHz) +8% pilot dev.	Stereo L-channel (1,000 Hz)	VTVM to R-channel output (TAPE OUT R channel)	98.0 MHz (P2)	IF BAND WIDE R301/ NARROW R302 so that channel separation is identical between both channels. (At this time, needs adjust the NARROW at first next adjust the wide.)
2		Stereo R-channel (1,000 Hz)	VTVM to L-channel output (TAPE OUT L channel)		
3	Repeat steps 1 and 2.				

5. AM Alignment Procedures

(Function switch at "AM" position)

● **AM IF Alignment**

Step	Signal Source Connection	Signal Frequency	Indicator Connection	Digital Readout Frequency Setting	Adjust
1	Sweep generator to AM antenna terminal	450 kHz	AC VTVM to L- or R-channel output (TAPE OUT)	—	LA06 maximum and symmetrical waveform.

● **AM RF Alignment**

Step	Signal Source Connection	Signal Frequency	Indicator Connection	Digital Readout Frequency Setting	Adjust
1	AM signal generator to AM loop antenna in a test loop	603 kHz	VTVM to L- or R-channel output (TAPE OUT)	603 kHz (P5)	LA01 for maximum output.
2		1,404 kHz		1,404 kHz (P7)	CA01 for maximum output.
3	Repeat steps 1 and 2 until sensitivity is maximized.				

● **AM Auto Stop Check**

(Function switch at "AM" position)

Step	Signal Source Connection	Signal Frequency	Indicator Connection	Digital Readout Frequency Setting	Check
1	RF generator to AM loop antenna in a test loop (1000 μ V/m)	999 kHz	—	999 kHz (P6)	Initiate auto scan operation and check that the scanning stops at the frequency of the SG.

10. ALIGNMENT AND TEST POINT

PI04

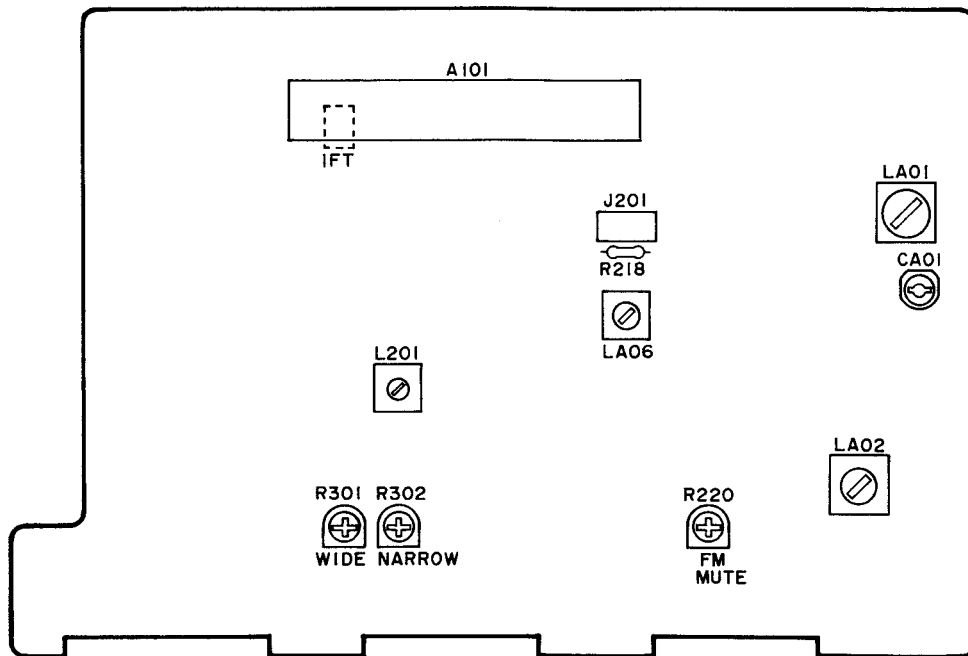

11. CIRCUIT DESCRIPTION

1. Input Selector, Multi Room Selector and Dubbing Selector

- **Input selector**
The function of this circuit is to select between the components connected to the rear panel. The circuit uses an LC7821 IC (QV01), which is serially controlled by the microprocessor (QU01).
- **Multi room selector**
This circuit functions as a switch to select which input is heard in the "multi room" when the unit is in multi room mode. The circuit uses an LC7822 IC (QV03), which is serially controlled by the microprocessor.
The multi room selector can select between CD/TAPE and the preset channel of the tuner, and it can also select the source selected by the input selector.
- **Dubbing selector**
This circuit has two independent functions for copying from TAPE to VCR1 or from VCR1 to VCR2 using an LC7823 IC (QV02). These functions are serially controlled by the microprocessor. The same IC also functions to switch the front video input.
- **Buffer amplifiers**
Buffer amplifiers (QV01, QV02) are located between the input side of the CD and TAPE and the output side of the input selector in order to prevent switching noise caused by mutual switching between the multi room selector and input selector.

2. Surround Block

- The surround block consists of a buffer amplifier, phase shifter, peak indicator amplifier, Dolby Pro Logic decoder and its controller, and digital delay and surround mode switches.
- **Buffer amplifier**
The stereo signal is first input into this buffer amplifier (QF01), which provides a 12 dB gain at all frequencies. After passing through the amplifier, the signal is distributed to the various blocks.
- **Phase shifter and adder**
Here the phase of the signal from low range to high range frequencies is shifted. First, the L/R signals are input to the QM02-2 and the L-R (phase difference component) signal is extracted. This L-R signal passes through the phase shifter (QM03, QM04-1) and then enters the matrix circuit (QM01). Here the L-R signal is applied in reverse phase to the L signal and in same phase to the R signal. These signals then become the front L and R signals for the MATRIX and HALL surround modes. The adder (QM02-1) produces an L+R signal which is used as the surround signal in the HALL surround mode and as the L channel signal in SIMULATED STEREO mode.
- **Peak indicator amplifier**
The L/R signals from the buffer amplifier (QE01) are half-wave rectified by diodes DP01 and DP02 and then added. The half-wave rectified signal is amplified by 32 dB by an op amp (QM04-2). The amplified signal is rectified again by a diode and capacitor to become a DC voltage (approx. 4.5V) which is input to pin 14 of the microprocessor (QU01) to light the peak indicator.

- **Dolby Pro Logic decoder**

This circuit uses a Pro Logic decoder to decode a Dolby-encoded signal into four signals for the front left, front right, center and surround channels. The IC used is an NJM2175L (Q601). This circuit operates together with center mode control.

This IC has 2-channel and 3-channel modes in addition to the Dolby Pro Logic 4-channel mode, but in this unit the IC is used for 4-channel operation only. (See the Q601 Function Table.) Also, the center mode is controlled by the μ PD6345C (Q603) and TC9214P (Q604).

The signal output from the buffer amplifier (QF01) is input to the L and R input pins of the Dolby Pro Logic decoder (Q601, pins 17 and 18). The front L and R channel signals decoded here are then output from pins 36 and 38 of Q601 and input to the surround mode selector (QM05). These signals are then output as the front L and R channel signals whenever the unit is set to Dolby surround mode. In the same way, the center signal is output from pin 41 of Q601 and input to the master volume (RG01).

The surround signal is output from pin 42 of Q601, input to the surround mode selector (QM05), and then sent to the digital delay circuit (Q602). After the signal is applied with a delay in this circuit, it is returned to the Q601 and input to the Dolby B decoder circuit. The signal is then output from pin 31 of Q601 as the final surround signal. After that, the signal passes through QM05 and enters the master volume (RG01).

There are four center modes—NORMAL, PHANTOM, WIDE and OFF. Control of these modes is carried out by the TC9214P (Q604), which is in turn controlled by the port expander μ PD6345C (Q603). The center mode control signal from the microprocessor is input as serial data from pins 36, 46 and 47 of QU01 to pins 3, 13 and 14 of Q603 to set each of Q603's ports to H or L. The control pins of the analog switch (Q604) connected to these ports turn the internal switches ON/OFF to control the Q601's center mode. (See the Q601 Function Table.) When the center mode is set to NORMAL, the center channel signal's low-frequency component is output to the front L and R channels. In PHANTOM mode, since no center speaker is used, the entire center channel signal is distributed to the front L and R channels. When set to OFF—the mode where no center channel is output—the center channel signal is used when adjusting the balance. The Q603, in addition to controlling the center mode, also carries out control of the Q601 noise sequencer and the motor used for the master volume control. The noise sequencer functions to generate the signal used to adjust the balance of each channel in Dolby Pro Logic mode. When the TEST TONE switch is pressed ON, the noise sequencer outputs pink noise to each channel in sequence at 1.5-second intervals in the order: L → CENTER → R → SURROUND → L. (See the Q601 Function Table.)

NJM2175L (Q601) Function Table

NOISE SEQUENCER				OPERATION MODE		
PIN NAME PIN No.	NOISE-CNT-E PIN 26	NOISE-CNT-A PIN 27	NOISE-CNT-B PIN 28	PIN NAME PIN No.	MODE-CNT PIN 33	Note
SIGNAL SELECT	H	X	X	2CH (Lt, Rt, S')	L	S' = Lt-Rt or NOISE
NOISE L	L	L	L	3CH (L, C, R, S')	High Z	S' = Lt-Rt or NOISE
NOISE C	L	L	H	4CH (L, C, R, S', S)	H	
NOISE R	L	H	L	CENTER MODE		
NOISE S	L	H	H	PIN NAME PIN No.	CENTER-CNT PIN 32	CENTER-MODE PIN 40
				CENTER OFF	L	X
				NORMAL	H	0.22 μ F
				PHANTOM	H	OPEN
				WIDEBAND	H	10 μ F

- **Digital delay**

This circuit uses the M50198 (Q602) to add a time delay to the surround channel signal when a surround mode is selected, and is controlled by the microprocessor.

10 kHz active filters (L.P.F.) are placed on both the input side and output side of the delay circuit. Each filter has a gain of 0 dB. The delay times used for the various modes are as follows:

DOLBY: 15 ~ 30 ms, MATRIX/HALL/SIMULATED:
5 ~ 40 ms

Initial delay settings are as follows:

DOLBY/MATRIX/HALL: 20 ms, SIMULATED:
10 ms

● Surround mode selector

The LC7821 (QM05) is used for the surround mode selector, which switches the surround modes in the following sequence:

OFF → DOLBY → MATRIX → HALL → SIMULATED

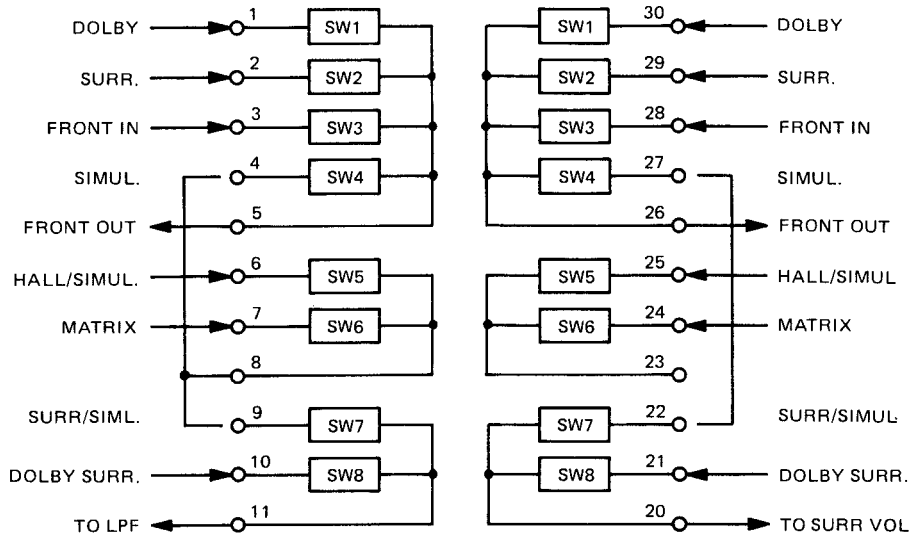
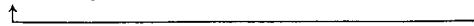

LC7821 (QM05) Function Table

SURROUND SELECTOR	SWITCH No.							
	1	2	3	4	5	6	7	8
OFF	0	0	1	0	X	X	X	X
DOLBY	1	0	0	0	0	0	0	1
MATRIX	0	1	0	0	0	1	1	0
HALL	0	1	0	0	1	0	1	0
SIMULATED STEREO	0	0	0	1	1	0	1	0

0 = SWITCH OFF
 1 = SWITCH ON
 X = DON'T CARE

3. Master Volume

● The master volume (RG01) is a motor-driven quadruple potentiometer for controlling the volume of the front left, front right, center and surround channels. Control of the motor is carried out by the LB1630 (Q605). Q605 is a motor drive IC with pins 1 and 4 used for input and pins 5 and 8 used for output.

LB1630 (Q605) Function Table

Volume	Input		Output	
	1	4	5	8
UP	L	H	H	L
DOWN	H	L	L	H
STOP	L	L	L	L

Q605 is controlled by the μ PD6345C (Q603). Q603 is controlled by serial data from the microprocessor.

4. Center/Surround Volume

● Electronic potentiometers (TC9213P) are used for the center channel volume (QG01) and surround channel volume (QG03). One potentiometer consists of an element for varying the volume in 10 dB steps and an element for varying the volume in 1 dB steps. Buffer amplifiers (QG02 or QG04, NJM4558DD) are located between the elements.

In multi room mode, QG01 functions as the surround channel volume and QG03 functions as the multi room volume.

Key Matrix

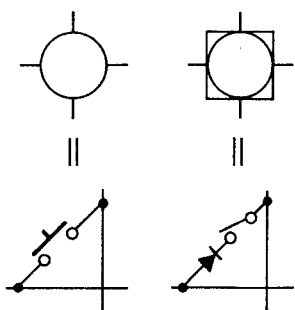
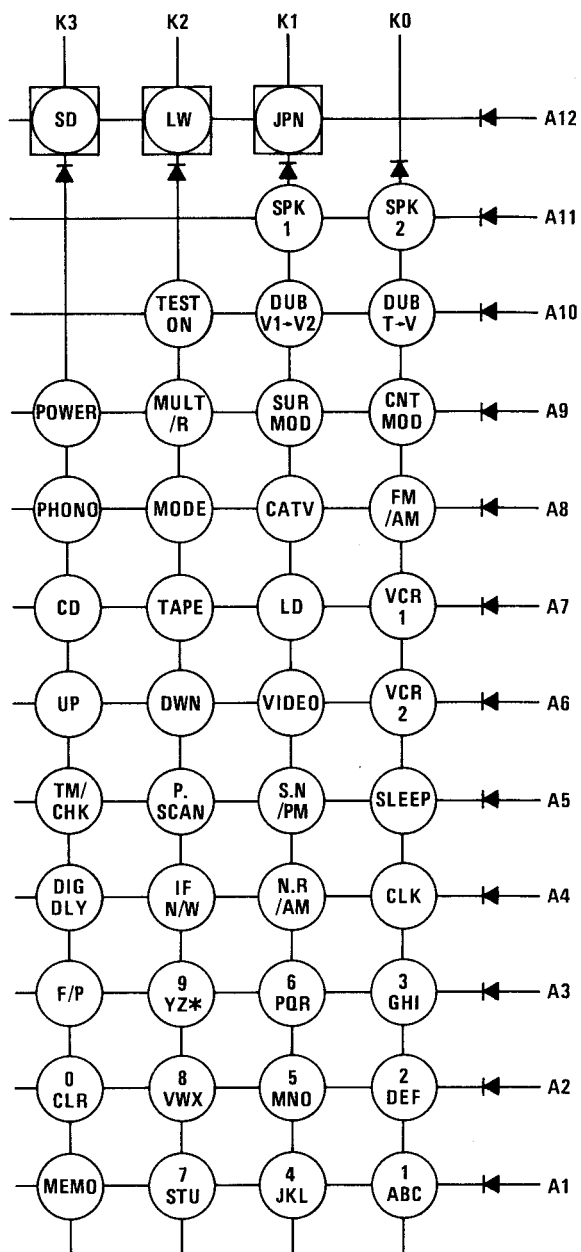

Description of Keys

1. Diode Switches (for initial settings)

 : Used to switch the tuner frequency band. When pressed ON, the AM band unconditionally becomes MW and LW. The FL display shows MW and LW.

 : Used to switch the tuner frequency band. When pressed ON, the band is unconditionally switched to the Japan version.



Resetting the initial settings: Initial settings are recalled when HOLD goes from LO to HI while the POWER key is held pressed.

2. Momentary Switches and Lock Switches (switches are momentary unless indicated otherwise)

 : This key turns ON when an SD signal is input in TUNER mode. When turned ON, the stipulated operation is carried out. (Lock switch)

 : Used to set the unit to clock mode. When this key is pressed, the FL display switches to the clock display and stays in clock mode until the current general operation is completed.

 : Used to set the unit to timer mode and to check the program contents after the timer is set. If this key is pressed after a timer program has been set, the program contents are shown on the FL display in the specified sequence. If no timer program is set, the unit enters timer mode allowing the user to select the timer program or to set the timer to execute or standby mode.

 ~  : Used for entering numbers and alphabetic characters when recalling preset stations and entering station names. A space can be inserted by entering the *symbol with the  key. Although these keys are normally used as numeric keys, when the S.N/PM (Station Name/PM) key is pressed to set the unit to station name preset mode, they are used for entering alphabetic characters. One press enters the first alphabetic from the left (e.g., "A" when the ABC key is pressed), and subsequent pressing allows the user to select one of the key's four characters in sequence (e.g., A → B → C → 1 → A).

 : Used for entering "0" and also as a CLEAR key in various modes.

 : This is the sleep timer mode key, used for operations such as turning the sleep timer mode ON/OFF.

 : Used as a noise reduction switch and for entering AM/PM in clock mode and timer mode. The setting of the N.R switch is included in data sent to the PLL. When used as an N.R switch, noise reduction is alternately switched ON and OFF.

 : Used to switch the IF band between NARROW and WIDE. This switch normally functions only in FM mode, but can also function in AM mode depending on the initial settings. It is included in PLL port data.

- DIG OLY** : This is the digital delay control key. When pressed, the current delay time is displayed for five seconds, during which time the delay time can be changed using the UP or DOWN key.
- P. SCAN** : Used for automatically scanning the tuner's preset channels. When this key is pressed, the FL display's "PRESET SCAN" segments blink and preset scanning can be started by pressing the UP or DOWN key.
- MEMO** : Used to enter a memory mode such as preset memory, timer set or station name preset mode, or to complete the memory operation.
- POWER** : Turns the power ON/OFF. This is a non-lock switch which turns the power ON and OFF alternately. When turned OFF, all output ports except for specified ports are become LO level, but specified input ports and the remote control input port remain accessible.
- F/P** : This is the Frequency/Preset key used for switching the FL display mode between the frequency display and preset display. The initial setting is the frequency display mode. The frequency and preset display modes are switched in cyclic sequence. The UP/DOWN keys and other keys function differently depending on the display mode.
- CNT MOD** : Used for selecting the mode of the center channel used in surround mode. Operation of this key is coupled with the surround mode key and is valid only in Dolby mode.
- SUR MOD** : This key selects the surround mode and is accessible at all times.
- MULT /R** : Used for setting the unit to multi room mode. In multi room mode, certain restrictions apply to the surround modes. Also, the volume control for the center and surround channels is switched for use as the multi room volume control.
- S.N /PM** : Used to set the station name preset mode and for entering the PM indicator in clock mode. Operation as the station name key is valid only in tuner mode.
- SPK 1**, **SPK 2** : Used for selecting the speaker system. These keys are initially set to OFF (port is LO) and switch ON/OFF in cyclic sequence. The corresponding output ports switch ON/OFF. Current settings are stored by the last memory function.
- TEST ON** : The signal used for adjusting the Dolby surround level is turned ON/OFF by this key. The initial setting is OFF. When switched ON, the unit unconditionally enters Dolby surround mode and the surround mode selector is set.
- DUB V1-V2**, **DUB T-V** : These are dubbing switch keys which control the input selector data.
- PHONO**, **VCR 1**, **VCR 2**, **CD**, **LD**, **TAPE**, **VIDEO** : These are input selector keys. Each key outputs the corresponding serial data.
- MODE** : Switches the FM mode between stereo and monaural. When the AM/STEREO initial setting is set, this switch can also be used to switch the AM mode between stereo and monaural. Switching is carried out by serial data sent to the PLL. In either case, the initial mode is stereo. Switch operation is cyclic. In stereo mode, "AUTO" lights in the FL display.
- CATV** : Controls the CATV dedicated port in the FM band. When CATV is selected, the CATV port goes HI. The FL display normally shows "CATV" in this case. If JPN is set, however, the FL display shows "ANT B".
- FM /AM** : Used to switch the tuner frequency band. The initial setting is FM. Switch operation is cyclic. When two bands are set the FL display is "FM/AM", and when LW is added the display is "FM.MW/LW". The band is switched in the sequence: FM → MW → LW → FM.
- UP**, **DWN** : Used for increasing/decreasing the tuner frequency or preset channel number. UP adds and DOWN subtracts. Operation differs depending on the mode set by the F/P key. In frequency mode, the keys increase/decrease the frequency, and in preset mode, the keys increase/decrease the preset channel number. In station name preset mode, the keys function as cursor keys for selecting the character input position.

* Except for special cases (service mode), when several keys are pressed the last-pressed key has priority.

12. MICROPROCESSOR DATA

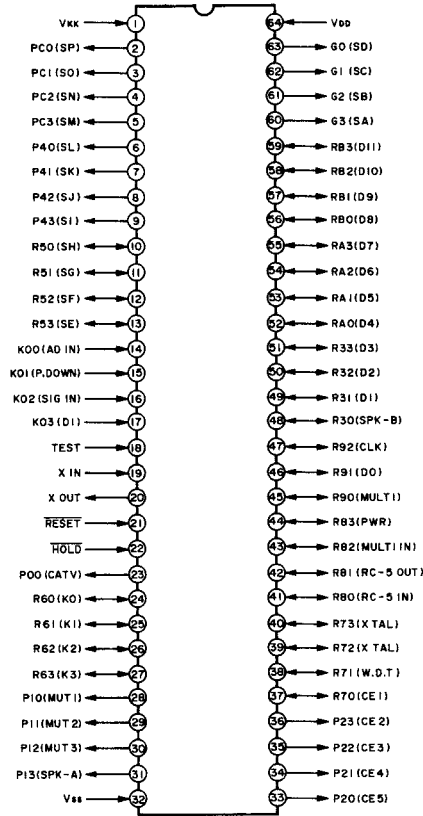

Pin Nbr.	Pin Name	I/O	Active	Function	Pin Nbr.	Pin Name	I/O	Active	Function
1	VKK	—	—	−35V (FL Display Drive)	33	P20 (CE5)	O	H	Digital Delay Control
2	PC0 (SP)	O	H	FL P-segment/Key Switch (A12)	34	P21 (CE4)	O	H	Surround/Multi Room Volume Chip Enable
3	PC1 (SO)	O	H	FL O-segment/Key Switch (A11)	35	P22 (CE3)	O	H	Center/Surround Volume Chip Enable
4	PC2 (SN)	O	H	FL N-segment/Key Switch (A10)	36	P23 (CE2)	O	H	Port Expander Chip Enable
5	PC3 (SM)	O	H	FL M-segment/Key Switch (A9)	37	R70 (CE1)	O	H	Analog Switch/PLL Chip Enable
6	P40 (SL)	O	H	FL L-segment/Key Switch (A8)	38	R71 (W.D.T)	O	L	Watch-Dog Timer
7	P41 (SK)	O	H	FL K-segment/Key Switch (A7)	39	R72 (XTAL)	I	—	Slow Mode Clock (32.768 kHz)
8	P42 (SJ)	O	H	FL J-segment/Key Switch (A6)	40	R73 (XTAL)	O	—	
9	P43 (SI)	O	H	FL I-segment/Key Switch (A5)	41	R80 (RC-5 IN)	I	L	Remote Control (RC-5) Input
10	R50 (SH)	O	H	FL H-segment/Key Switch (A4)	42	R81 (RC-5 OUT)	O	H	Remote Control (RC-5) Output
11	R51 (SG)	O	H	FL G-segment/Key Switch (A3)	43	R82 (MULTI IN)	I	L	Remote Control (Multi Room) Input
12	R52 (SF)	O	H	FL F-segment/Key Switch (A2)	44	R83 (PWR)	O	H	Power Relay Drive
13	R53 (SE)	O	H	FL E-segment/Key Switch (A1)	45	R90 (MULTI)	O	H	Multi Room Mode
14	K00 (AD IN)	I	—	Analog Input	46	R91 (DO)	O	H	Serial Data
15	K01 (P. DOWN)	I	L	Power On/Off (Off = L)	47	R92 (CLK)	O	H	Serial Clock
16	K02 (SIG. IN)	I	—	Signal Strength Indicator	48	R30 (SPK-B)	O	H	Speaker-B Relay
17	K03 (DI)	I	H	Serial Data Input	49	R31 (D1)	O	H	FL Display D1 Digit
18	TEST	—	—	Not Used	50	R32 (D2)	O	H	FL Display D2 Digit
19	X IN	I	—	Clock (4.19 MHz)	51	R33 (D3)	O	H	FL Display D3 Digit
20	X OUT	O	—		52	RA0 (D4)	O	H	FL Display D4 Digit
21	RESET	I	L	Reset and Watch-Dog Timer	53	RA1 (D5)	O	H	FL Display D5 Digit
22	HOLD	I	L	Hold Mode	54	RA2 (D6)	O	H	FL Display D6 Digit
23	P00 (CATV)	O	H	Relay Trigger Output for CATV	55	RA3 (D7)	O	H	FL Display D7 Digit
24	R60 (K0)	I	H	Key Switch	56	RB0 (D8)	O	H	FL Display D8 Digit
25	R61 (K1)	I	H		57	RB1 (D9)	O	H	FL Display D9 Digit
26	R62 (K2)	I	H		58	RB2 (D10)	O	H	FL Display D10 Digit
27	R63 (K3)	I	H		59	RB3 (D11)	O	H	FL Display D11 Digit
28	P10 (MUT1)	O	H	Front Muting	60	G3 (SA)	O	H	FL Display A-segment
29	P11 (MUT2)	O	H	Center/Surround Muting	61	G2 (SB)	O	H	FL Display B-segment
30	P12 (MUT3)	O	H	Surround Muting	62	G1 (SC)	O	H	FL Display C-segment
31	P13 (SPK-A)	O	H	Speaker-A Relay	63	G0 (SD)	O	H	FL Display D-segment
32	VSS	—	—	GND	64	VDD	—	—	+5.5V

REF. DESIG.	PART NO.	DESCRIPTION
PE04-SEMICONDUCTORS		
QE01	4822 130 42298	Transistor 2SC536SP, etc.
QE02	4822 130 42298	Transistor 2SC536SP, etc.
QE03	4822 130 61892	Transistor 2SD2144S (U, V)
QE04	4822 130 61892	Transistor 2SD2144S (U, V)
QE05	4822 209 73064	IC NJM2068DD
QE06	4822 130 42594	Transistor, digital DTC144ES
QE07	4822 130 42682	Transistor, digital DTA144ES
PE04-MISCELLANEOUS		
JE05	4822 267 31274	Jack, Headphone
SE01	4822 276 13428	Push Switch, Bass EQ
PG04-MASTER VOLUME CIRCUIT BOARD		
CG51	4822 122 30043	Ceramic Cap. 0.01 μ F +80% -20%
RG01	4822 100 12044	100K Ω (B) x 4, Variable Resist
PJ04-PRE-OUT, MAIN-IN TERMINAL CIRCUIT BOARD		
CJ02	4822 122 30043	Ceramic Cap. 0.01 μ F +80% -20%
CJ03	4822 122 30043	Ceramic Cap. 0.01 μ F +80% -20%
JJ01	4822 290 61173	Terminal, 4P; RCA Jack
JJ02	4822 290 61173	Terminal, 4P; RCA Jack
JJ03	4822 290 61171	Terminal, 2P; RCA Jack
PL04-VIDEO SELECTOR CIRCUIT BOARD		
PL04-CAPACITORS		
CL05	4822 124 21894	Elect 10 μ F 16V
CL06	4822 124 21894	Elect 10 μ F 16V
CL07	4822 124 21894	Elect 10 μ F 16V
PL04-RESISTORS		
RL01 RL07	4822 111 41355	75 Ω \pm 5% 1/6W
PL04-SEMICONDUCTORS		
DL01 DL06	4822 130 33305	Diode 1SS176, etc.
QL01	4822 209 31538	IC LC7824
QL02	4822 209 32513	IC MC14576AP
QL03	4822 209 32513	IC MC14576AP
PL04-MISCELLANEOUS		
JL01	4822 265 30627	Terminal, RCA; 3P Pin Jack
JL02	4822 266 30303	Terminal, RCA; 4P Pin Jack
PU04-μ-PROCESSOR & SWITCH CIRCUIT BOARD		
PU04-CAPACITORS		
CU01	4822 124 80651	Elect 100 μ F 6.3V
CU02	4822 124 23295	Elect, Big 0.22F 5.5V
CU03	4822 124 80651	Elect 100 μ F 6.3V
CU04	4822 122 40586	Ceramic 0.01 μ F \pm 20%
CU06	4822 122 31823	Ceramic 15pF \pm 5%
CU07	4822 122 31823	Ceramic 15pF \pm 5%
CU08	4822 124 41604	Elect 0.1 μ F 50V
CU09	4822 124 21894	Elect 10 μ F 16V
CU55	4822 122 40586	Ceramic 0.01 μ F \pm 20%
CU56	4822 122 40586	Ceramic 0.01 μ F \pm 20%

REF. DESIG.	PART NO.	DESCRIPTION
PU04-RESISTORS		
Δ RU51	4822 053 10109	10 Ω \pm 5% 1W
GU01	4822 111 91399	100K Ω x 4, Compo.
GU02	4822 111 92152	10K Ω x 6, Compo.
GU03	4822 111 92152	10K Ω x 6, Compo.
PU04-SEMICONDUCTORS		
DU01 DU16 DU19 DU26	4822 130 33305	Diode 1SS176, etc.
QU01	4822 209 32517	Microprocessor TMP47C1670AN
QU02	4822 130 42715	Transistor 2SA608SP, etc.
QU03	4822 130 61892	Transistor 2SD2144S (U, V)
QU04	4822 130 42682	Transistor, digital DTA144ES
QU06	4822 130 42298	Transistor 2SC536SP, etc.
QU07	4822 130 42594	Transistor, digital DTC144ES
QU08	4822 130 42682	Transistor, digital DTA144ES
QU09	4822 130 42298	Transistor 2SC536SP, etc.
QU10	4822 130 42682	Transistor, digital DTA144ES
QU11	4822 130 61189	Transistor, digital DTC114TS
QU51	4822 209 32514	IC L78MR06
PU04-MISCELLANEOUS		
SU01 SU39 SU51	4822 276 20508	Push Switch
4822 276 13429		Push Switch
VU01	4822 130 91257	Display Unit, FIP13BM10
XU01	4822 242 72194	Ceramic Resonator 4.19MHz
XU02	4822 242 72236	Crystal 32.768KHz
PU74-IR SENSOR CIRCUIT BOARD		
DU71	4822 130 80326	L. E. D. LT3D8B (RED)
QU71	4822 130 81254	Photo Unit GP1U52XH
PV04-MAIN AMP/FUNCTION SELECT CIRCUIT BOARD		
PV04-CAPACITORS		
CG14	4822 122 40617	Ceramic 0.1 μ F +80% -20%
CG15	4822 122 40617	Ceramic 0.1 μ F +80% -20%
CG16	4822 122 40617	Ceramic 0.1 μ F +80% -20%
CG17	4822 122 40617	Ceramic 0.1 μ F +80% -20%
CN04	4822 122 30043	Ceramic 0.01 μ F +80% -20%
CN08	4822 122 30043	Ceramic 0.01 μ F +80% -20%
CN09	4822 122 30043	Ceramic 0.01 μ F +80% -20%
CV01	4822 122 40617	Ceramic 0.1 μ F +80% -20%
CV02	4822 122 40617	Ceramic 0.1 μ F +80% -20%
CV03	4822 122 40617	Ceramic 0.1 μ F +80% -20%
CV10	4822 122 30103	Ceramic 0.022 μ F +80% -20%
C403	4822 124 21894	Elect 10 μ F 16V
C404	4822 124 21894	Elect 10 μ F 16V
C419	4822 122 30043	Ceramic 0.01 μ F +80% -20%
C705	4822 122 32072	Ceramic 33pF \pm 5%
C706	4822 122 32072	Ceramic 33pF \pm 5%
C711	4822 126 10797	Ceramic 10pF \pm 0.5pF
C712	4822 126 10797	Ceramic 10pF \pm 0.5pF
C713	4822 122 40367	Ceramic 7pF \pm 0.5pF
C714	4822 122 40367	Ceramic 7pF \pm 0.5pF
C717	4822 122 32265	Ceramic 100pF \pm 5%

REF. DESIG.	PART NO.	DESCRIPTION
C718	4822 122 32265	Ceramic 100pF ±5%
C719	4822 122 32265	Ceramic 100pF ±5%
C720	4822 122 32265	Ceramic 100pF ±5%
C727	4822 124 80649	Elect 10μF 100V
C728	4822 124 80649	Elect 10μF 100V
C729	4822 122 30043	Ceramic 0.01μF +80% -20%
C760	4822 122 32185	Ceramic 10pF ±0.5pF
C761	4822 122 32185	Ceramic 10pF ±0.5pF
C762	4822 122 32185	Ceramic 10pF ±0.5pF
C764	4822 124 80649	Elect 10μF 100V
C774	4822 124 41134	Elect 10μF 63V
C777		
C801	4822 122 30043	Ceramic 0.01μF +80% -20%
C802	4822 122 30043	Ceramic 0.01μF +80% -20%
S801	4822 122 30043	Ceramic 0.01μF +80% -20%
PV04-RESISTORS		
RN01	4822 052 10102	1K Ω ±5% 1/6W
RN02	4822 052 10102	1K Ω ±5% 1/6W
RN13	4822 052 10109	10 Ω ±5% 1/6W
RN14	4822 052 10109	10 Ω ±5% 1/6W
RN21	4822 052 10109	10 Ω ±5% 1/6W
RN22	4822 052 10109	10 Ω ±5% 1/6W
RN23	4822 052 10109	10 Ω ±5% 1/6W
▲ R417	4822 050 21021	100 Ω ±5% 1/4W
▲ R418	4822 050 21021	100 Ω ±5% 1/4W
▲ R713	4822 050 26809	68 Ω ±5% 1/6W
▲ R714	4822 050 26809	68 Ω ±5% 1/6W
R719	4822 100 11386	1K Ω, Trimming
R720	4822 100 11386	1K Ω, Trimming
▲ R725	4822 050 26809	68 Ω ±5% 1/6W
▲ R730		
▲ R731	4822 053 10221	220 Ω ±5% 1W
▲ R732	4822 053 10221	220 Ω ±5% 1W
▲ R733	4822 052 10229	22 Ω ±5% 1/6W
▲ R736		
▲ R737	4822 116 82049	0.18 Ω x 2 3W, Comp
▲ R738	4822 116 82049	0.18 Ω x 2 3W, Comp
▲ R739	4822 050 26809	68 Ω ±5% 1/6W
▲ R740	4822 050 26809	68 Ω ±5% 1/6W
▲ R743	4822 053 11109	10 Ω ±5% 2W
▲ R744	4822 053 11109	10 Ω ±5% 2W
▲ R745	4822 053 10472	4.7K Ω ±5% 1W
R747	4822 053 11331	330 Ω ±5% 2W
R748	4822 053 11331	330 Ω ±5% 2W
▲ R766	4822 052 10479	47 Ω ±5% 1/6W
▲ R769		
▲ R770	4822 116 82733	470 Ω ±2% 1/4W, Fusible
▲ R771	4822 113 80363	0.22 Ω ±5% 3W
▲ R772	4822 113 80363	0.22 Ω ±5% 3W
▲ R773	4822 113 80363	0.22 Ω ±5% 3W
▲ R774	4822 117 10419	4.7 Ω ±5% 2W
▲ R775	4822 053 10478	4.7 Ω ±5% 1W
▲ R776	4822 053 10478	4.7 Ω ±5% 1W
▲ R801	4822 116 60306	1 Ω ±5% 1/2W, Fusible
▲ R802	4822 116 60306	1 Ω ±5% 1/2W, Fusible
PV04-SEMICONDUCTORS		
▲ DN01	4822 130 80837	Diode HSS81TD
▲ DN02	4822 130 80837	Diode HSS81TD
DN03	4822 130 33305	Diode 1SS176, etc.
DN04	4822 130 33305	Diode 1SS176, etc.
DN06	4822 130 33305	Diode 1SS176, etc.
DN10		
DN51	4822 130 33305	Diode 1SS176, etc.
DN52	4822 130 33305	Diode 1SS176, etc.
DN53	4822 130 33305	Diode 1SS176, etc.

REF. DESIG.	PART NO.	DESCRIPTION
DN54	4822 130 80837	Diode HSS81TD
DN55	4822 130 33305	Diode 1SS176, etc.
DN56	4822 130 33305	Diode 1SS176, etc.
DN71	4822 130 42848	Posistor PTH487
D701	4822 130 80273	Zener RD8.2JB2/MTZJ8.2C
D702	4822 130 80322	Zener RD15JB3/MTZJ16A
D703	4822 130 33305	Diode 1SS176, etc.
D706		
▲ D801	4822 130 80839	Diode S5688G
▲ D805		
▲ QN01	4822 130 43233	Transistor 2SC2240 (GR, BL)
▲ QN02	4822 130 43233	Transistor 2SC2240 (GR, BL)
▲ QN03	4822 130 42951	Transistor 2SA970 (GR, BL)
QN04	4822 130 43312	Transistor 2SC3312 (R, S)
QN05	4822 130 43312	Transistor 2SC3312 (R, S)
QN06	4822 209 83312	IC TA7317P
QN07	4822 130 42594	Transistor, digital DTC144ES
QN08	4822 130 61723	Transistor, digital DTC323TS
QN09	4822 130 62682	Transistor, digital DTA144ES
QN10	4822 130 42594	Transistor, digital DTC144ES
QN11	4822 130 42594	Transistor, digital DTC144ES
▲ QN51	4822 130 43233	Transistor 2SC2240 (GR, BL)
▲ QN52	4822 130 43233	Transistor 2SC2240 (GR, BL)
▲ QN53	4822 130 43233	Transistor 2SC2240 (GR, BL)
▲ QN54	4822 130 42951	Transistor 2SA970 (GR, BL)
QN71	4822 130 61227	Transistor, digital DTA114ES
QN72	4822 130 61892	Transistor 2SD2144S (U, V)
QG01	4822 209 31575	IC TC9213P
QG02	4822 209 83631	IC NJM4558DD
QG03	4822 209 31575	IC TC9213P
QG04	4822 209 83631	IC NJM4558DD
QS01	4822 209 83631	IC NJM4558DD
QS02	4822 130 61892	Transistor 2SD2144S (U, V)
QS03	4822 130 42682	Transistor, digital DTA144ES
QS04	4822 130 42594	Transistor, digital DTC144ES
QV01	4822 209 72748	IC LC7821
QV02	4822 209 73731	IC LC7823
QV03	4822 209 73321	IC LC7822
QV04	4822 130 42594	Transistor, digital DTC144ES
QV05	4822 130 42682	Transistor, digital DTA144ES
QV06	4822 130 61892	Transistor 2SD2144S (U, V)
QV07	4822 130 42594	Transistor, digital DTC144ES
QV08	4822 130 42682	Transistor, digital DTA144ES
QV09	4822 130 61892	Transistor 2SD2144S (U, V)
QV10	4822 130 61892	Transistor 2SD2144S (U, V)
Q401	4822 209 83631	IC NJM4558DD
▲ Q701	4822 130 42999	Transistor 2SA1145 (O, Y)
▲ Q702	4822 130 42999	Transistor 2SA1145 (O, Y)
▲ Q703	4822 130 43283	Transistor 2SC2705 (O, Y)
▲ Q704	4822 130 43283	Transistor 2SC2705 (O, Y)
▲ Q705	4822 130 60117	Transistor 2SC3419
▲ Q706	4822 130 60117	Transistor 2SC3419
▲ Q707	4822 130 62335	Transistor 2SD2033 (E)
▲ Q708	4822 130 62335	Transistor 2SD2033 (E)
▲ Q709	4822 130 62334	Transistor 2SB1353 (E)
▲ Q710	4822 130 62334	Transistor 2SB1353 (E)
▲ Q711	4822 130 43306	Transistor 2SC3182 (R, O)
▲ Q712	4822 130 43306	Transistor 2SC3182 (R, O)
▲ Q713	4822 130 43019	Transistor 2SA1265 (R, O)
▲ Q714	4822 130 43019	Transistor 2SA1265 (R, O)
▲ Q715	4822 209 83732	IC AN7062N
▲ Q751	4822 209 32515	IC STK4219MK2
▲ Q801	4822 209 60826	IC NJM7812FA
▲ Q802	4822 209 73954	IC NJM7912FA
▲ Q803	4822 209 31631	IC NJM7805FA
▲ Q804	4822 209 63179	IC NJM7905FA

REF. DESIG.	PART NO.	DESCRIPTION
		PV04-MISCELLANEOUS
JV01	4822 265 30457	Terminal, 6P; RCA Jack
JV02	4822 265 30457	Terminal, 6P; RCA Jack
JV03	4822 265 30397	Terminal, 4P; RCA Jack
JV04	4822 266 30274	Terminal, 2P; RCA Jack
JV05	4822 290 61172	Terminal, 2P; RCA Jack
J401	4822 267 30741	Terminal, 2P; RCA Jack
▲ LN01		
	4822 280 70354	Relay, VB24MBU-510
▲ LN06		
▲ LN07	4822 280 20196	Relay, L-24 (M)
L701	4822 157 70022	Air Coil
L702	4822 157 70022	Air Coil
L751	4822 157 70022	Air Coil
L752	4822 157 70022	Air Coil
L753	4822 157 70022	Air Coil
		PV54-CD/TAPE BUFFER AMP CIRCUIT BOARD
		PV54-CAPACITORS
CV51	4822 124 21894	Elect 10μF 16V
CV52	4822 124 21894	Elect 10μF 16V
CV55		
	4822 124 21894	Elect 10μF 16V
CV58		
CV61		
	4822 124 21894	Elect 10μF 16V
CV64		
		PV54-SEMICONDUCTORS
QV51	4822 209 83631	IC NJM4558DD
QV52	4822 209 83631	IC NJM4558DD
		PV74-BUFFER AMP CIRCUIT BOARD
		PV74-CAPACITORS
CV71	4822 124 22318	Elect 10μF 16V
CV72	4822 124 21894	Elect 10μF 16V
CV75	4822 124 22318	Elect 10μF 16V
CV76	4822 124 21894	Elect 10μF 16V
		PV74-SEMICONDUCTOR
QV71	4822 209 83631	IC NJM4558DD
		PW04-FRONT SPEAKER CIRCUIT BOARD
		PW04-MISCELLANEOUS
CW01		
	4822 122 30043	Ceramic Cap. 0.01μF +80% -20%
CW06		
JW01	4822 290 60837	Terminal, SPK
JW02	4822 290 60836	Terminal, SPK
		PW54-CENTER/SURROUND SPK TERM. CIRCUIT BOARD
		PW54-MISCELLANEOUS
CW51		
	4822 122 30043	Ceramic Cap. 0.01μF +80% -20%
CW57		
JW51	4822 290 60686	Terminal, 8P SPK
JW53	4822 290 81567	Terminal, 2P SPK

REF. DESIG.	PART NO.	DESCRIPTION
		P104-FM FRONT END & FM/AM IF CIRCUIT BOARD
		P104-CAPACITORS
CA01	4822 125 60185	Trimming 20pF VCT51E
CA02	4822 122 30103	Ceramic 0.022μF +80% -20%
CA03	4822 122 31823	Ceramic 15pF ±5%
CA04	4822 122 31205	Ceramic 47pF ±5%
CA05	5322 121 54128	Film 390pF ±5%
CA06	4822 122 30043	Ceramic 0.01μF +80% -20%
CA15	4822 122 30043	Ceramic 0.01μF +80% -20%
CA16	4822 124 23053	Elect 1μF 50V
CA17	4822 122 30043	Ceramic 0.01μF +80% -20%
CA19	4822 124 23053	Elect 1μF 50V
CA20	4822 124 21894	Elect 10μF 16V
CA21	4822 122 30043	Ceramic 0.01μF +80% -20%
CA22	4822 122 30043	Ceramic 0.01μF +80% -20%
CA25	4822 122 40306	Ceramic 0.047μF +80% -20%
C102	4822 122 30043	Ceramic 0.01μF +80% -20%
C201		
	4822 122 30043	Ceramic 0.01μF +80% -20%
C206		
C207	4822 122 30103	Ceramic 0.022μF +80% -20%
C208	4822 122 30103	Ceramic 0.022μF +80% -20%
C209	4822 124 21894	Elect 10μF 16V
C210	4822 122 30043	Ceramic 0.01μF +80% -20%
C211	4822 124 41604	Elect 0.1μF 50V
C213	4822 124 23053	Elect 1μF 50V
C214	4822 126 10935	Elect 100μF 6.3V
C216	4822 122 30103	Ceramic 0.022μF +80% -20%
C218	4822 122 30043	Ceramic 0.01μF +80% -20%
		P104-RESISTORS
R220	4822 100 11471	100K Ω, Trimming
R221	4822 050 21501	150 Ω ±5% 1/4W
R301	4822 100 11373	4.7K Ω, Trimming
R302	4822 100 11373	4.7K Ω, Trimming
		P104-SEMICONDUCTORS
DA01	4822 125 50416	Varicap, SVC342-K
DA08	4822 130 33305	Diode 1SS176, etc.
DA09	4822 130 33305	Diode 1SS176, etc.
D101	4822 130 33305	Diode 1SS176, etc.
D201		
	4822 130 33305	Diode 1SS176, etc.
D204		
D301	4822 130 33305	Diode 1SS176, etc.
Q101	4822 130 42298	Transistor 2SC536SP, etc.
Q201	4822 209 71785	IC LA1266
Q202	4822 130 62294	Transistor 2SC1809S (P)
Q203	4822 130 62294	Transistor 2SC1809S (P)
Q206	4822 130 42715	Transistor 2SA608SP, etc.
Q302	4822 130 42715	Transistor 2SA608SP, etc.
Q304	4822 130 42715	Transistor 2SA608SP, etc.
Q305	4822 130 42298	Transistor 2SC536SP, etc.
Q306	4822 130 42298	Transistor 2SC536SP, etc.
Q307	4822 130 42121	F. E. T. 2SK30A (Y)
		P104-MISCELLANEOUS
A101	4822 210 10567	V. H. F. Tuner, FE415-G02
F201	4822 242 71135	Ceramic Filter SFF10.7MS3-A
F202	4822 242 71135	Ceramic Filter SFF10.7MS3-A
F203	4822 242 71135	Ceramic Filter SFF10.7MS3-A
J101	4822 290 81632	Terminal, FM/AM Ant
J102	4822 264 30254	Terminal, F Connector
LA01	4822 157 63084	Ant Coil, MW 280μH
LA02	4822 157 52716	OSC Coil, MW
LA05	4822 157 53589	Choke Coil, TL-8 393J
LA06	4822 242 71509	Ceramic Filter, SFL450J3
L101	4822 280 20442	Relay, UM1-12W-K
L201	4822 148 81096	I. F. T. FM Det Coil
L203	4822 156 10794	M. P. X. Coil

REF. DESIG.	PART NO.	DESCRIPTION
		P304-FM MPX & PLL SYNTHESIZER CIRCUIT BOARD
		P304-CAPACITORS
CA23	4822 122 31349	Ceramic 68pF ±5%
CA24	4822 122 30043	Ceramic 0.01µF +80% -20%
C217	4822 122 31349	Ceramic 68pF ±5%
C302	4822 124 21894	Elect 10µF 16V
C306	4822 124 23056	Elect 47µF 16V
C309		
C312	4822 124 23053	Elect 1µF 50V
C313	4822 124 41604	Elect 0.1µF 50V
C315	4822 124 23053	Elect 1µF 50V
C316	4822 124 23053	Elect 1µF 50V
C317	4822 124 21894	Elect 10µF 16V
C318	4822 122 30043	Ceramic 0.01µF +80% -20%
C321	4822 122 32185	Ceramic 10pF ±0.5pF
C322	4822 122 32185	Ceramic 10pF ±0.5pF
C501	4822 122 31205	Ceramic 47pF ±5%
C502	4822 122 31205	Ceramic 47pF ±5%
C503	4822 124 10935	Elect 100µF 10V
C504	4822 122 30043	Ceramic 0.01µF +80% -20%
C505	4822 124 23053	Elect 1µF 50V
C506	4822 124 41604	Elect 0.1µF 50V
C507	4822 122 30043	Ceramic 0.01µF +80% -20%
C508	4822 124 23056	Elect 47µF 16V
C509	4822 124 41604	Elect 0.1µF 50V
		P304-RESISTORS
▲ R305	4822 050 21501	150 Ω ±5% 1/4W
R306	4822 100 20672	100K Ω, Trimming
▲ R505	4822 116 83929	220 Ω ±5% 1/4W
G501	4822 111 92152	10K Ω x 6, Compo.
		P304-SEMICONDUCTORS
DA05	4822 130 33305	Diode 1SS176, etc.
D302	4822 130 33305	Diode 1SS176, etc.
D303	4822 130 33305	Diode 1SS176, etc.
D501	4822 130 80317	Zener RD5.1JB2/MTZJ5.1B
QA04	4822 130 42715	Transistor 2SA608SP, etc.
Q204	4822 130 60495	Transistor 2SA1309A (Q, R)
Q205	4822 130 60495	Transistor 2SA1309A (Q, R)
Q301	4822 209 32516	IC LA3433
Q303	4822 209 83631	IC NJM4558DD
Q501	4822 209 30178	IC LC7218
Q502	4822 130 42121	F. E. T. 2SK30A (Y)
Q503	4822 130 42298	Transistor 2SC536SP, etc.
		P304-MISCELLANEOUS
X301	4822 242 71511	Ceramic Resonator, CSB456F11
X501	4822 242 72333	Crystal, AD0618CTB 7.2MHz
		P604-SURROUND MODE CONTROL CIRCUIT BOARD
		P604-CAPACITORS
CF01	4822 124 23053	Elect 1µF 50V
CF02	4822 124 23053	Elect 1µF 50V
CM01	4822 124 23053	Elect 1µF 50V
CM02	4822 124 23053	Elect 1µF 50V
CM04	4822 124 23053	Elect 1µF 50V
CM06	4822 124 23053	Elect 1µF 50V
CM10	4822 124 23053	Elect 1µF 50V
CM15	4822 122 31205	Ceramic 47pF ±5%
CM18	4822 124 23053	Elect 1µF 50V
CM24	4822 122 30043	Ceramic 0.01µF +80% -20%
CM25	4822 122 30043	Ceramic 0.01µF +80% -20%

REF. DESIG.	PART NO.	DESCRIPTION
CP02	4822 124 23053	Elect 1µF 50V
C618	4822 124 23055	Elect 22µF 16V
C642	4822 126 11127	Ceramic 470pF ±10%
C654	4822 122 30043	Ceramic 0.01µF +80% -20%
C664	4822 122 40617	Ceramic 0.1µF +80% -20%
		P604-RESISTORS
R647	4822 050 22209	22 Ω ±5% 1/4W
		P604-SEMICONDUCTORS
DP01		
DP04	4822 130 33305	Diode 1SS176, etc.
D602	4822 130 80839	Diode S5688G
D603	4822 130 33305	Diode 1SS176, etc.
D604	4822 130 33305	Diode 1SS176, etc.
QF01	4822 209 83631	IC NJM4558DD
QM01		
QM04	4822 209 83631	IC NJM4558DD
QM05	4822 209 72748	IC LC7821
Q601	4822 209 31572	IC NJM2175L
Q602	4822 209 31573	IC M50198P
Q603	4822 209 31574	IC µPD6345C
Q604	4822 209 73275	IC TC9214P
Q605	4822 209 73287	IC LB1630
		P604-MISCELLANEOUS
X601	4822 242 81271	Ceramic Resonator, 3.27MHz
		P904-CNT/SURR. POWER SUPPLY CIRCUIT BOARD
		P904-CAPACITORS
▲ C901	4822 124 80646	Elect 8200µF 56V
▲ C902	4822 124 80646	Elect 8200µF 56V
▲ C903	4822 126 12453	Ceramic 0.01µF +80% -20%
▲ C904	4822 124 80645	Elect 4700µF 45V
▲ C905	4822 124 80645	Elect 4700µF 45V
▲ C906	4822 126 12453	Ceramic 0.01µF +80% -20%
		P904-RESISTORS
▲ R901	4822 117 10417	15 Ω ±5% 3W
▲ R902	4822 117 10418	68 Ω ±5% 1/2W, Fusible
▲ R903	4822 053 11479	47 Ω ±5% 2W
▲ R904	4822 111 20384	6.8 Ω ±5% 1/2W, Fusible
		P904-SEMICONDUCTORS
▲ D901	4822 130 33132	Diode D5FB20
▲ D902	4822 130 31007	Diode S4VB-20
▲ D903	4822 130 80839	Diode S5688G
▲ D904	4822 130 80839	Diode S5688G
		P904-MISCELLANEOUS
▲ F903	4822 070 33152	Fuse T3.15A 250V
▲ F904	4822 070 33152	Fuse T3.15A 250V

NOTE ON SAFETY :
Symbol ▲ Fire or electrical shock hazard. Only original parts should be used to replace any part marked with symbol ▲. Any other component substitution (other than original type), may increase risk of fire or electrical shock hazard.