



Service Bulletin
No. : MZ07-100
Date: November 7, 2007

Model: SR8200

Subject: Correction of the SCHEMATIC DIAGRAM.

Symptom: The SCHEMATIC DIAGRAM mentioned on the SR8200's Service Manual is not correct. (Service Manual page 43, 44)

Solution: Reference number QD05 shown on page 43, 44 of the service manual is not used in this model.

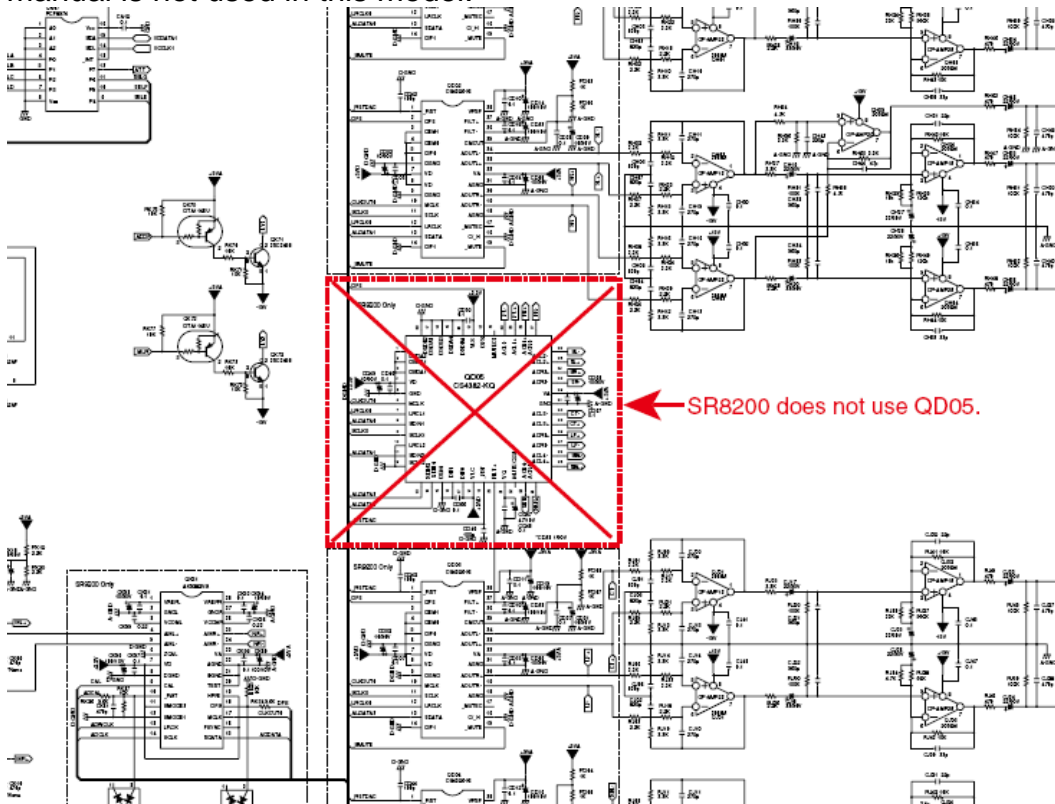

CONFIDENTIALITY NOTICE:

The information contained in this document is intended for the exclusive use by MARANTZ Authorized Service Centers and their employees. This document may contain information that is privileged, confidential and may be protected from disclosure under applicable laws and terms of the MARANTZ Service Agreement. Any distribution, disclosure, dissemination or copying of this document and the information it contains is prohibited. No responsibility will be accepted by MARANTZ for any damage, injury or loss resulting from the misuse of the information contained in this document.