

Service Manual

74 ST17 /02B /02G
ST-17 F_N U_{BL} K_{BL} K_{GL} K_{KGL}
Stereo tuner

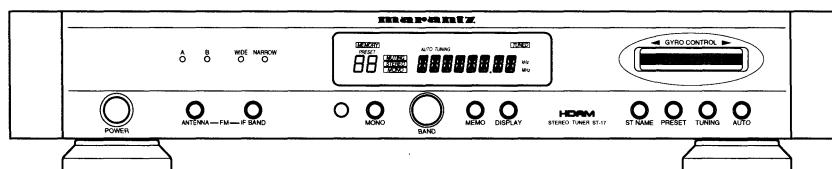

TABLE OF CONTENTS

SECTION	PAGE
1. TECHNICAL SPECIFICATIONS	1
2. BLOCK DIAGRAM	2
3. SCHEMATIC DIAGRAM AND PARTS LOCATION (Pattern Side)	3
4. EXPLODED VIEW AND PARTS LIST	11
5. SERVICE PROGRAM	14
6. TUNER ALIGNMENT PROCEDURES	15
7. ALIGNMENT AND TEST POINT	18
8. MICROPROCESSOR SPECIFICATIONS	18
9. ELECTRICAL PARTS LIST	21

Please use this service manual with referring to the user guide (D.F.U) without fail.
修理の際には必ず取扱説明書を準備し操作方法を確認の上、作業を行って下さい。

marantz®

model ST-17

MARANTZ DESIGN AND SERVICE

Using superior design and selected high grade components, **MARANTZ** company has created the ultimate in stereo sound. Only original **MARANTZ** parts can insure that your **MARANTZ** product will continue to perform to the specifications for which it is famous.

Parts for your **MARANTZ** equipment are generally available to our National Marantz Subsidiary or Agent.

ORDERING PARTS :

Parts can be ordered either by mail or by Fax.. In both cases, the correct part number has to be specified.

The following information must be supplied to eliminate delays in processing your order :

1. Complete address
2. Complete part numbers and quantities required
3. Description of parts
4. Model number for which part is required
5. Way of shipment
6. Signature : any order form or Fax. must be signed, otherwise such part order will be considered as null and void.

USA

MARANTZ AMERICA, INC.
440 MEDINAH ROAD
ROSELLE, ILLINOIS 60172
USA
PHONE : 630 - 307 - 3100
FAX : 630 - 307 - 2687

CANADA

LENBROOK INDUSTRIES LIMITED
633 GRANITE COURT,
PICKERING, ONTARIO L1W 3K1
CANADA
PHONE : 905 - 831 - 6333
FAX : 905 - 831 - 6936

EUROPE / TRADING

MARANTZ EUROPE B. V.
P.O.BOX 80002
BUILDING SFF2
5600 JB EINDHOVEN
THE NETHERLANDS
PHONE : +31 - 40 - 2732241
FAX : +31 - 40 - 2735578

PROFESSIONAL USA

SUPERSCOPE TECHNOLOGIES, INC.
MARANTZ PROFESSIONAL PRODUCTS
1000 CORPORATE BLVD., SUITE D
AURORA, ILLINOIS 60504 USA
PHONE : 630 - 820 - 4800
FAX : 630 - 820 - 8103

PROFESSIONAL CANADA

TC ELECTRONICS CANADA LTD.
540 FIRING AVE.
BAIE D'URFÉ, QUEBEC H9X 3T2
CANADA
PHONE : 514 - 457 - 4044
FAX : 514 - 457 - 5524

KOREA

MK ENTERPRISES LTD.
2F SHINHAN BLDG., 247-17 SEOKYO-DONG
MAPO-KU, SEOUL
KOREA
PHONE : +82 - 2 - 323 - 2155
FAX : +82 - 2 - 323 - 2154

BRAZIL

MARANTZ BRAZIL
CAIXA POSTAL 21462
CEP 04698-970
SAO PAULO, SP, BRAZIL
PHONE : 0800 - 123123 (Discagem Direta Gratuita)
FAX : +55 11 534. 8988

THAILAND

MRZ STANDARD CO., LTD.
746 - 754 MAHACHAI RD.,
WANGBURAPAPIROM, PHRANAKORN,
BANGKOK, 10200 THAILAND
PHONE : +66 - 2 - 222 - 9181
FAX : +66 - 2 - 224 - 6795

HONG KONG

FORWARD INTERNATIONAL CORP., LTD.
3/F., BLOCK-B, WO KEE HONG BLDG., 585-609
CASTLE PEAK RD., KWAI CHUNG, N.T.
HONG KONG
PHONE : +852 24942033
FAX : +852 24101656

AUSTRALIA / NEW ZEALAND

SCAN AUDIO PTY. LTD.
52 CROWN STREET, RICHMOND 3121
VICTORIA
AUSTRALIA
PHONE : +61 - 3 - 9429 - 2199
FAX : +61 - 3 - 9429 - 9309

TAIWAN

PAI - YUNG CO., LTD.
6 TH FL NO, 148 SUNG KIANG ROAD,
TAIPEI, 10429, TAIWAN R.O.C.
PHONE : +886 (2) 5221304
FAX : +886 (2) 5630415

MALAYSIA

WO KEE HONG ELECTRONICS SDN. BHD.
NO. 102 JALAN SS 21/35, DAMANSARA
UTAMA, 47400 PETALING JAYA
SELANGOR DARUL EHSAN,
MALAYSIA
PHONE : +60 3 - 7184666
FAX : +60 3 - 7173828

JAPAN *Technical*

MARANTZ JAPAN, INC.
35- 1, 7- CHOME, SAGAMIONO
SAGAMIHARA - SHI, KANAGAWA
JAPAN 228-8505
PHONE : +81 427 48 9379
FAX : +81 427 48 0889

日本マランツ株式会社

本 社 〒228-8505
神奈川県相模原市相模大野 7 - 35 - 1
営業本部 〒150-0022
東京都渋谷区恵比寿南 1 - 11 - 9

SINGAPORE

FORWARD MARKETING (S) PTE. LTD.
23, LORONG 8, TOA PAYOH,
SINGAPORE 319257.
PHONE : +65 2583640
FAX : +65 3564047

SHOCK, FIRE HAZARD SERVICE TEST :

CAUTION : After servicing this appliance and prior to returning to customer, measure the resistance between either primary AC cord connector pins (with unit NOT connected to AC mains and its Power switch ON), and the face or Front Panel of product and controls and chassis bottom.

Any resistance measurement less than 1 Megohms should cause unit to be repaired or corrected before AC power is applied, and verified before it is return to the user/customer.

Ref. UL Standard NO. 1492.

In case of difficulties, do not hesitate to contact the Technical Department at above mentioned address.

1. TECHICAL SPECIFICATIONS

FM Stage (87.5 ~ 108.0 MHz)

Mono usable sensitivity	11.3 dBf / 1.0 μV
Sensitivity of 50dB quieting	
Mono	16.8 dBf / 1.9 μV
Stereo	39.2 dBf / 25 μV
Total harmonic distortion	
(Dev.=75kHz : U version)	
(Dev.=40kHz : /02, K, KK Version)	
Mono	0.08 %
Stereo	0.12 %
Signal to noise ratio	
Mono	80 dB
Stereo	74 dB
Selectivity adjacent channel 98MHz	
Wide IF	40 dB
Narrow IF	60 dB
Stereo separation	55 dB
Accuracy of frequency response	
across 30 Hz ~ 15 kHz band width	+0.5 / -1.0 dB
Output level at 1 kHz deviation	940 mV

AM Stage (520 ~ 1710 kHz)---- U Version

Sensitivity (s / n 20 dB 30 % Mod.)	350 μV / m
Total harmonic distortion	0.3 %
Signal to noise ratio	52 dB

MW Stage (531 ~ 1602 kHz)---- /02, K, KK Version

Sensitivity (s / n 20 dB 30 % Mod.)	350 μV / m
Total harmonic distortion	0.3 %
Signal to noise ratio	52 dB

LW Stage (152 ~ 280 kHz)---- /02 Version

Sensitivity (s / n 20 dB 30 % Mod.)	1 mV / m
Signal to noise ratio	50 dB

General

Power requirements supply	
U version	120V AC, 60 Hz
/02 version	230V AC, 50 Hz
K, KK version	110/220V AC, 50/60 Hz
Power consumption	8.5 W
Dimensions (MAX)	
Width	458 mm
Height	86 mm
Depth	315 mm
Weight	6.8 kg

Design and specifications are subject to change without notice.

[FM部]

受信周波数範囲	76 MHz ~ 90 MHz
実用感度 (75Ωモノラル)	11.3dBf/1.0μV
S/N 50 dB感度 (モノラル)	16.8dBf/1.9μV
(ステレオ)	39.2dBf/25μV
高調波歪率 (モノラル)	0.08%
(ステレオ)	0.12%
S/N比 (モノラル)	80 dB
(ステレオ)	73 dB
実効選択度 WIDE	40 dB
NARROW	63 dB
ステレオセパレーション 1kHz	55 dB
周波数特性 30 Hz ~ 15 kHz	+0.5, -1.0 dB
イメージ妨害比	75 dB
IF 妨害比	100 dB
スプリアス妨害比	100 dB
AM抑圧比	70 dB
サブキャリア抑圧比	70 dB
出力レベル	940 mV

[AM部]

受信周波数範囲	531 kHz ~ 1602 kHz
実用感度 (LOOP)	350μV/m
高調波歪率 1 kHz (モノラル)	0.3%
S/N比 (モノラル)	52 dB
ステレオセパレーション 1kHz	30 dB
出力レベル/インピーダンス (30 %変調)	280mV/1.7kΩ

[その他]

電源電圧	AC 100V, 50Hz/60Hz
消費電圧 (電気用品取締法)	9W
最大外形寸法 (幅 x 高さ x 奥行き)	458 x 86 x 315 mm
質量	6.8 kg

[付属品]

カードリモコン(RC-17ST, ボタン電池CR2025x1, 同梱)	x1
FM T型アンテナ	x1
AMループアンテナ(一式)	x1
オーディオコード	x1
アンテナアダプター	x1
リモコンコード	x1

本機の規格および外観は改良のため予告なく変更することがありますが、ご了承ください。

2. BLOCK DIAGRAM

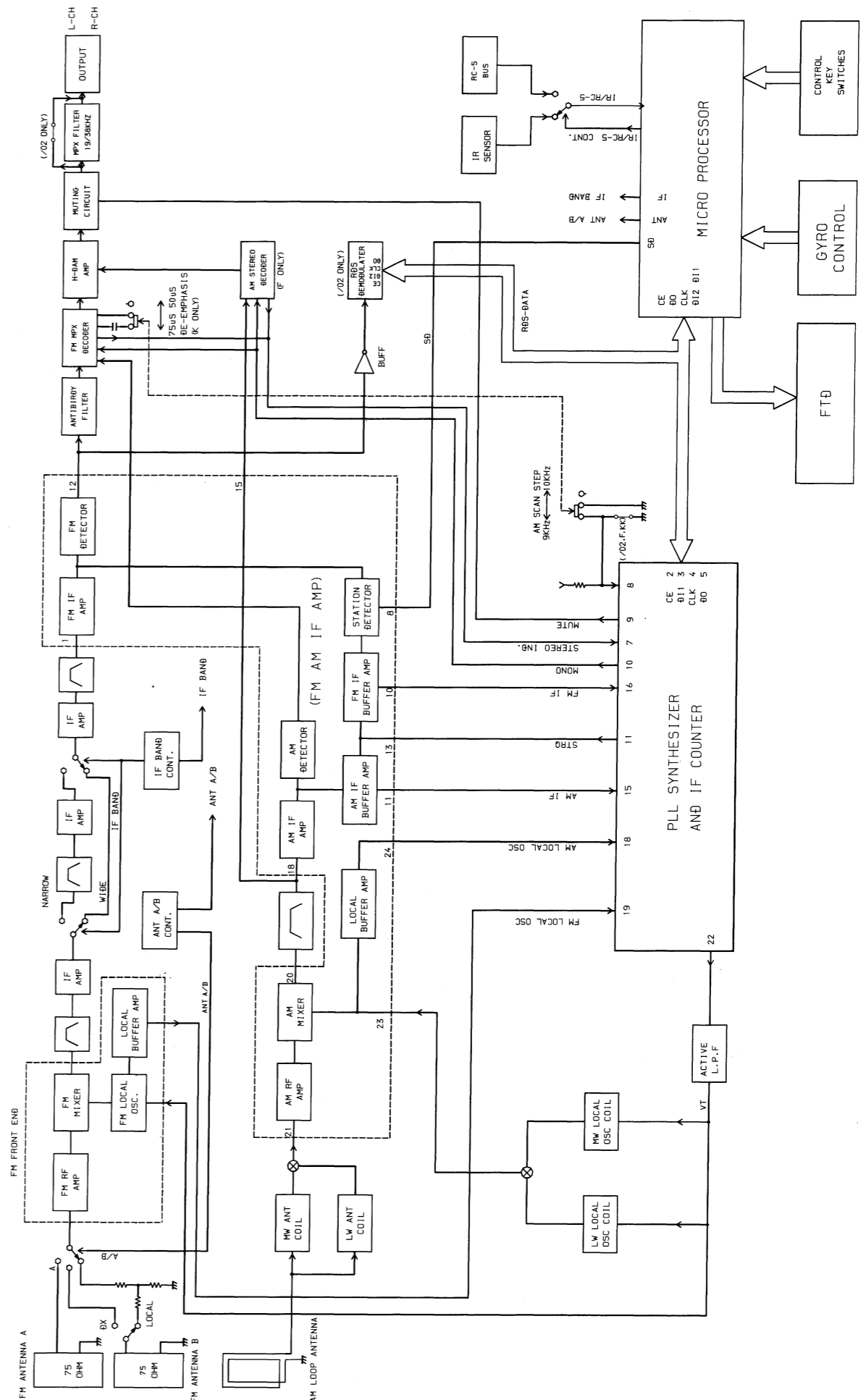

3. SCHEMATIC DIAGRAM AND PARTS LOCATION (Pattern side)

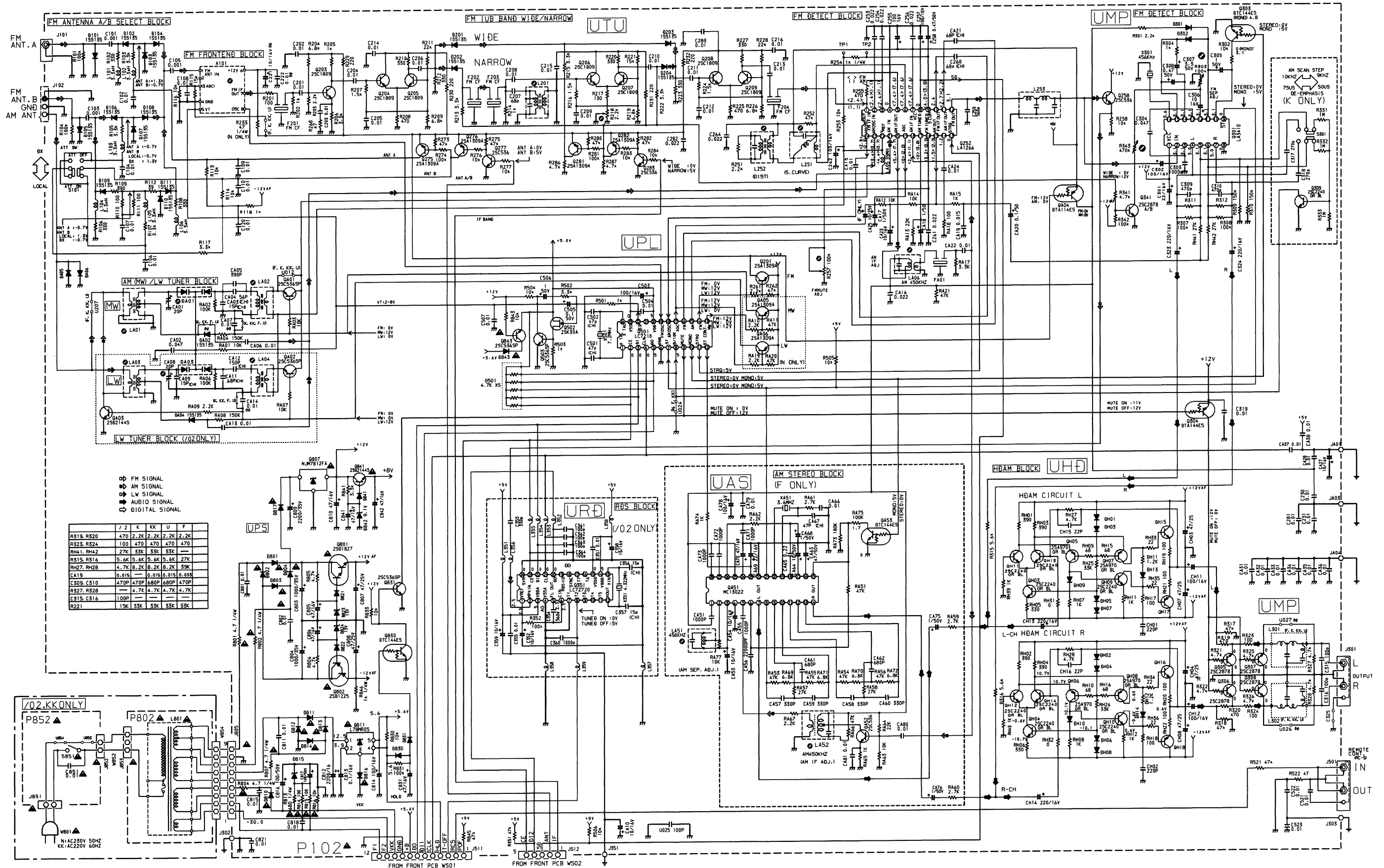

Q811 Q807 Q801 Q830 Q831 Q841 Q802 Q843 QH07 QH05 QH09 QH03 QH15 QH17 Q305 Q307 QA53 Q303 Q341 Q301 QH14 QH12 QH08 QH06 QH10 QH04 QH16 QH18 Q306 Q308 Q304 QA51 Q258 Q277 Q276 Q309 Q275 Q452 Q282 Q281 Q206 Q283 QA06 QA04 QA05 Q201 Q501 Q252 Q207 Q208 Q209 Q205 Q204 Q203 Q502 Q503 Q351 QA01 QA02 QA03

P102

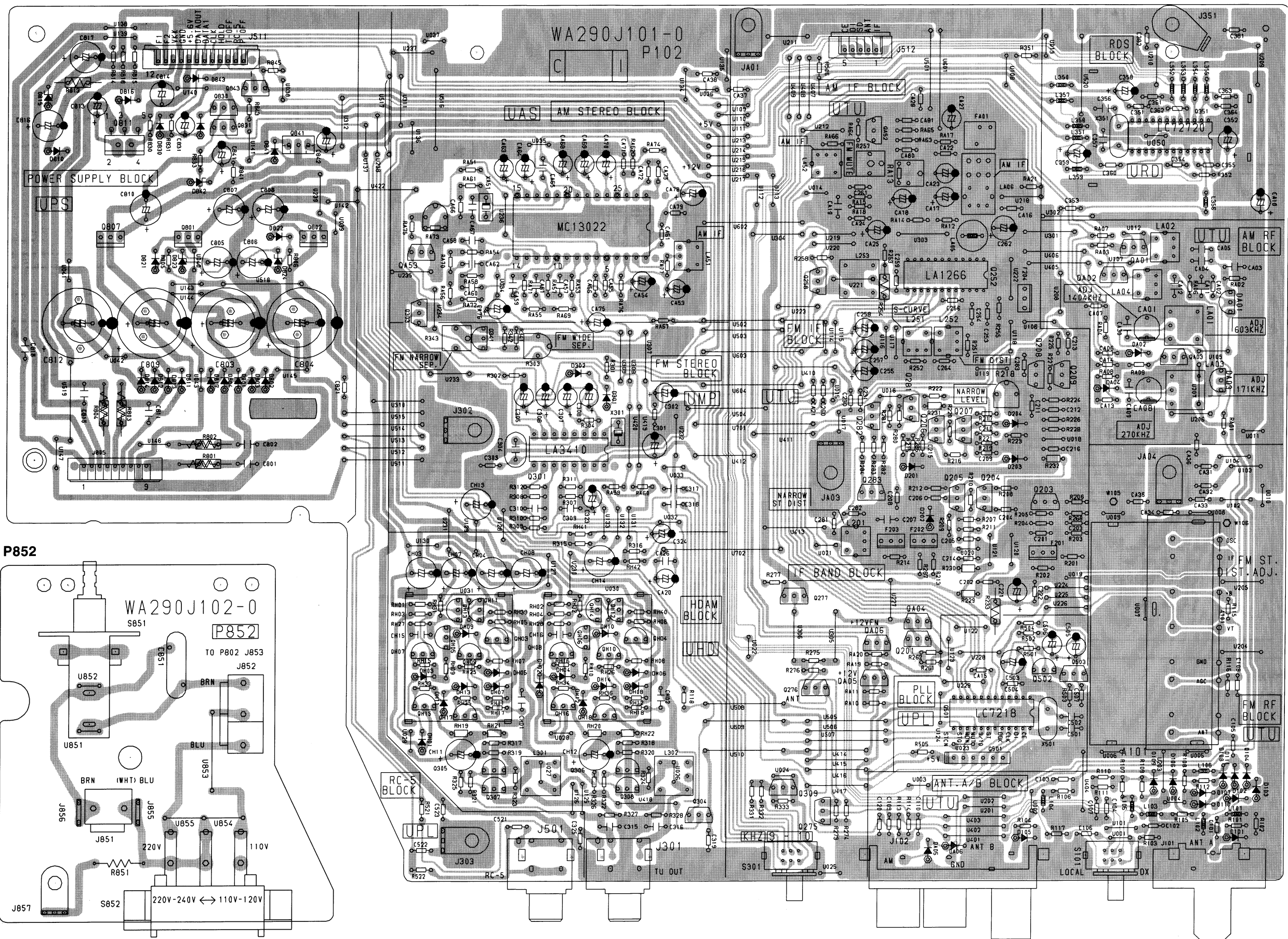

P852

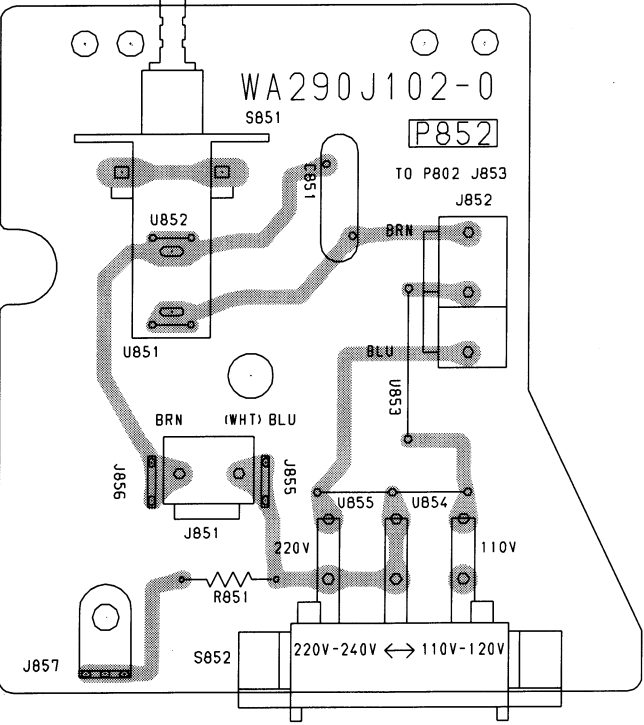

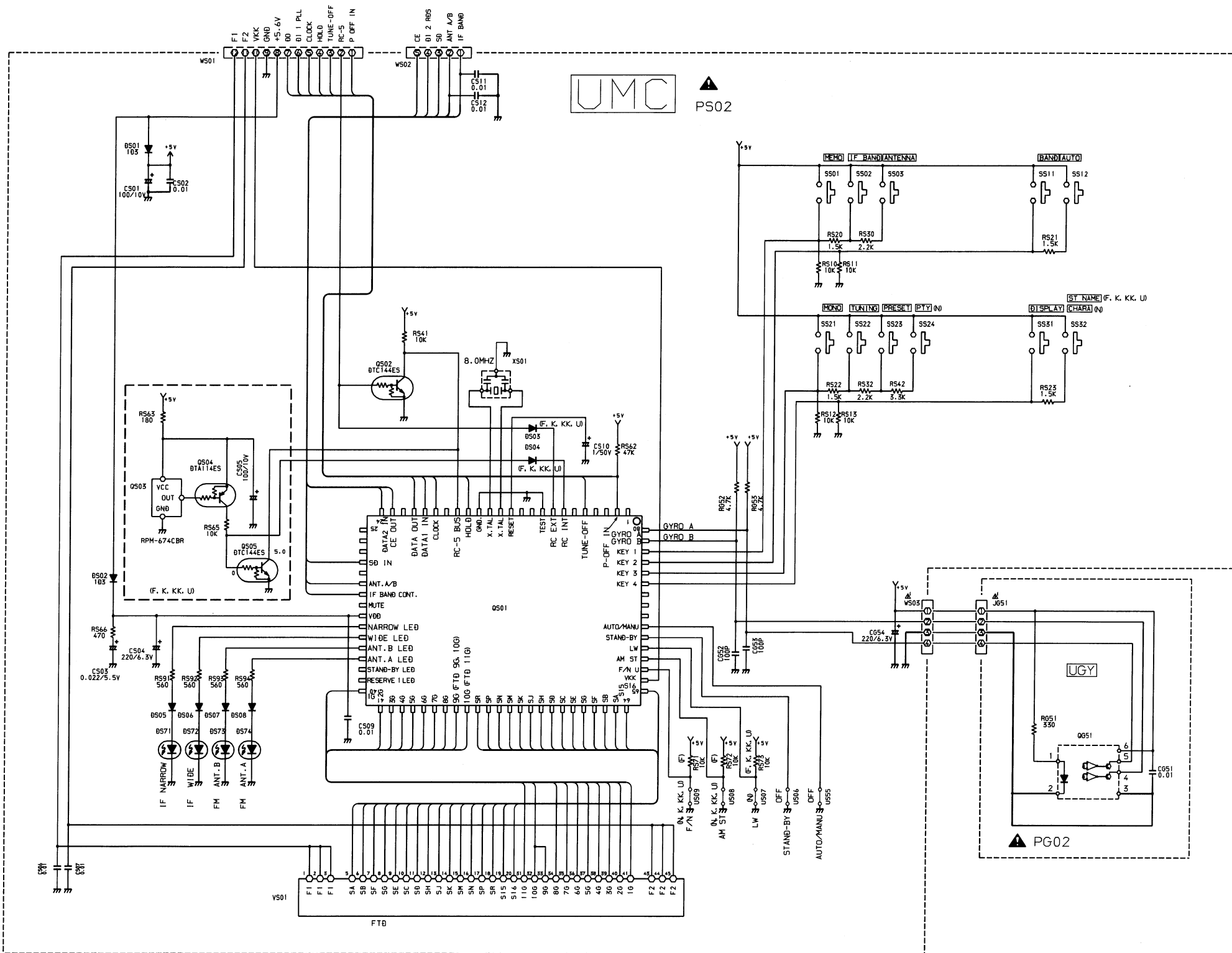

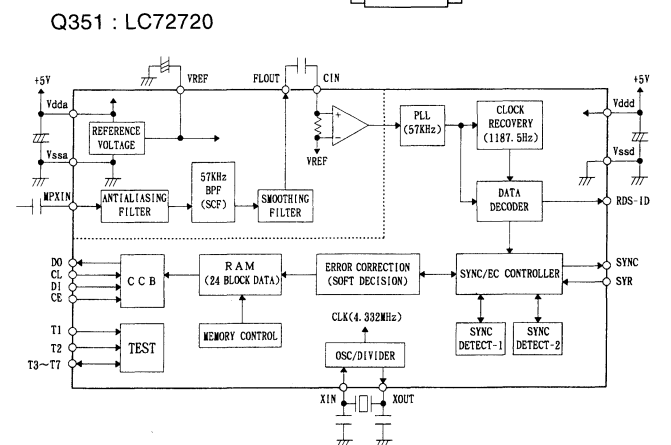
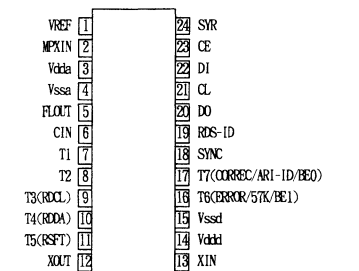
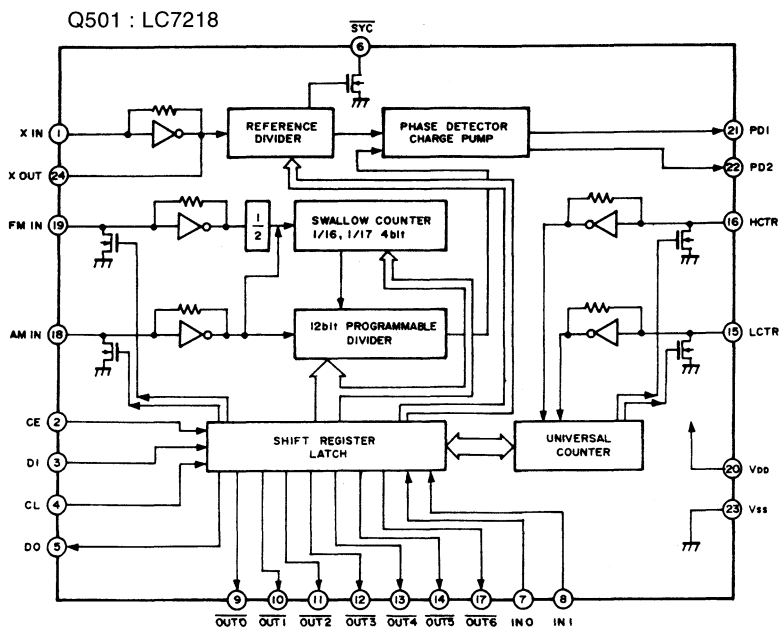
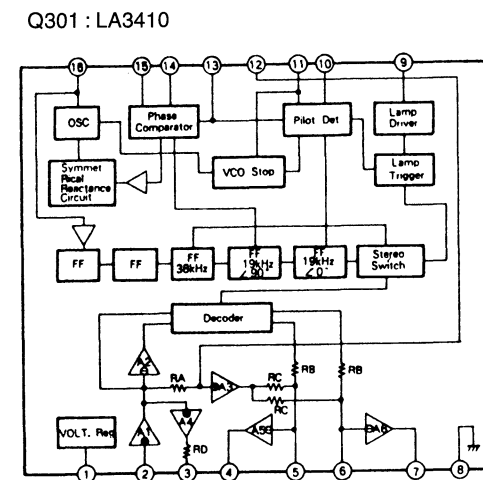
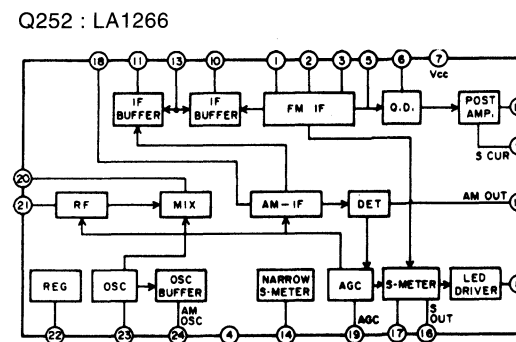
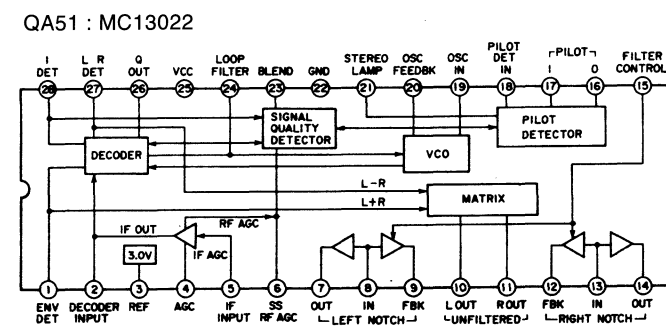
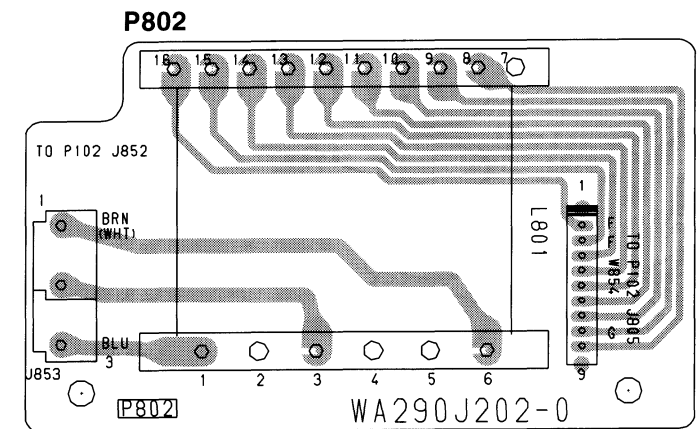
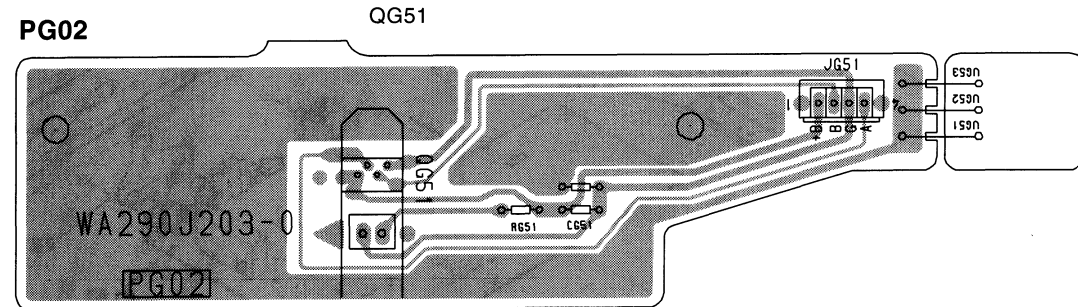
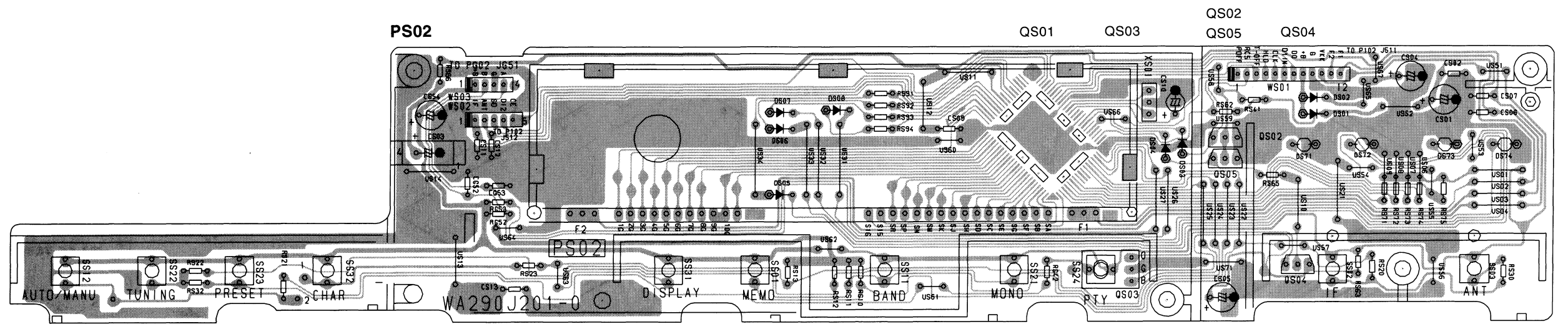

4. EXPLODED VIEW AND PARTS LIST

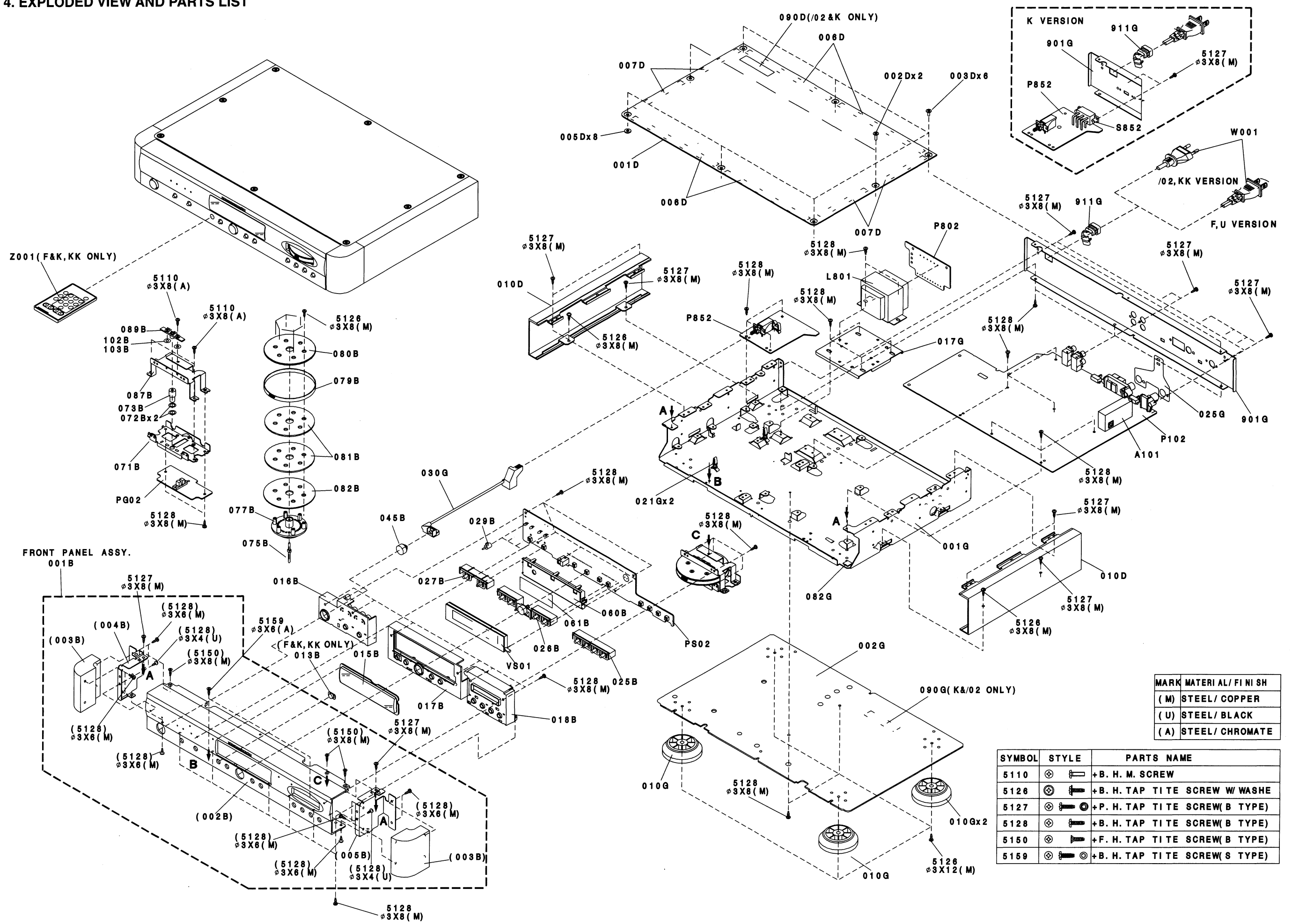

MARK	MATERIAL/ FINISH
(M)	STEEL/ COPPER
(U)	STEEL/ BLACK
(A)	STEEL/ CHROMATE

SYMBOL	STYLE	PARTS NAME
5110	⊗	+B. H. M. SCREW
5126	⊗	+B. H. TAP TITE SCREW W/ WASHE
5127	⊗	+P. H. TAP TITE SCREW(B TYPE)
5128	⊗	+B. H. TAP TITE SCREW(B TYPE)
5150	⊗	+F. H. TAP TITE SCREW(B TYPE)
5159	⊗	+B. H. TAP TITE SCREW(S TYPE)

POS. NO	VERS. COLOR	PART NO. (FOR PCS)	DESCRIPTION	PART NO. (MJI)
001B	FN,KGL KKGL		FRONT PANEL,ASSY GL	290J248530
001B	KBL UBL		FRONT PANEL,ASSY BL	290J248520
001B	/02B		FRONT PANEL,ASSY BL	290J248500
001B	/02G		FRONT PANEL, ASSY GL	290J248510
002B	FN,KGL KKGL		FRONT PANEL,AL GL	290J248310
002B	KBL UBL		FRONT PANEL,AL BL	290J248210
002B	/02B	4822 459 04894	FRONT PANEL,AL BL	290J248010
002B	/02G	4822 459 04895	FRONT PANEL,AL GL	290J248110
003B	GOLD	4822 444 40853	ESCUTCHEON,CORNER AL	318K063110
003B	BLACK	4822 444 40852	ESCUTCHEON,CORNER AL	318K063010
013B	FN,KGL KKGL		IR LENS FOR GL	290J355110
013B	KBL, UBL		IR LENS 3L	290J355010
015B	GOLD	4822 450 10143	WINDOW,PINK	318K158110
015B	BLACK	4822 450 10141	WINDOW,BLUE	318K158010
016B	GOLD		RETAINER,HOLDER L-SIDE	290J104110
016B	BLACK		RETAINER,HOLDER L-SIDE	290J104010
017B	GOLD		RETAINER,HOLDER FL-SIDE	290J104320
017B	BLACK		RETAINER,HOLDER FL-SIDE	290J104220
018B	GOLD		RETAINER,JYRO HOLDER GL	290J104130
018B	BLACK		RETAINER,JYRO HOLDER BL	290J104030
025B	GOLD	4822 410 11672	BUTTON FOR JYRO	290J270130
025B	BLACK		BUTTON FOR JYRO	290J270030
026B	GOLD		BUTTON FOR FL	290J270320
026B	BLACK		BUTTON FOR FL	290J270220
027B	GOLD	4822 410 70034	BUTTON FOR ANTENNA IF	318K270140
027B	BLACK	4822 410 70029	BUTTON FOR ANTENNA IF	318K270040
029B		4822 381 11939	LENS	252J355010
045B	GOLD	4822 410 70031	BUTTON POWER GL	318K270110
045B	BLACK	4822 410 70026	BUTTON POWER BL	318K270010
060B		4822 255 41068	FL HOLDER	066J271010
061B		4822 459 10942	STICKER,FL ADHESIVE	056J122020
072B			WASHER,SPACER FOR GYRO SHAFT 073B	59071102G0
073B			SHAFT,JYRO SUSTAINER DOWN-SIDE	290J112020
075B			SHAFT,JYRO MAIN	290J112010
077B			JYRO FLY WHEEL BASE	290J273010
079B	GOLD		JYRO ESC. RUBBER RING GL	290J066110
079B	BLACK		JYRO ESC. RUBBER RING BL	290J066010
080B	GOLD	4822 410 11676	JYRO ESC. DOWN & UP:GL	290J063110
080B	BLACK	4822 410 11675	JYRO ESC. DOWN & UP:BL	290J063010
082B	GOLD		JYRO ESC. DOWN & UP:GL	290J063110
082B	BLACK		JYRO ESC. DOWN & UP:BL	290J063010
089B			RETAINER,JYRO SUSTAINER UP-SIDE	290J104050
001D	GOLD	4822 444 30517	LID, TOP COVER AL GL	318K257110
001D	BLACK	4822 444 30516	LID, TOP COVER AL BL	318K257010
002D	GOLD	4822 502 14425	SCREW, THINHEAD 3x8	323S010020
002D	BLACK	4822 502 21693	SCREW, THINHEAD 3x8	323S010030
003D	GOLD	4822 502 14462	SCREW, THINHEAD 3x5	318K010020
003D	BLACK	4822 502 14461	SCREW, THINHEAD 3x5	318K010030
005D			TOP COVER SPACER	318K118010
010D	GOLD	4822 444 40855	SIDE PANEL GL	318K249110
010D	BLACK	4822 444 40854	SIDE PANEL BL	318K249010

POS. NO	VERS. COLOR	PART NO. (FOR PCS)	DESCRIPTION	PART NO. (MJI)
010G	GOLD	4822 462 42134	LEG,D60 H18,AL. GOLD SAND	291K057010
010G	BLACK	4822 462 42134	LEG,D60 H18,AL. GOLD SAND	291K057010
030G		4822 402 10913	LINK,POWER SW.	318K121010
▲ W001	F		MAINS CORD, F	YC01900180
▲ W001	K		MAINS CORD, AC250V 10A	YC01800880
▲ W001	KK		MAINS CORD, AC250V 7A	YC02000780
▲ W001	/02	4822 321 10985	MAINS CORD, /02	YC01800610
▲ W001	U		MAINS CORD, UL CSA	YC01800780
			PACKING	
001S	F		PACKING CASE GL	290J801020
001S	U		PACKING CASE BL	290J801010
002S	F,U		CUSHION L R	318K809010
001T	F		USER GUIDE	290J851110
001T	K		USER GUIDE	290J851350
001T	KK		USER GUIDE	290J851360
001T	/02	4822 736 15915	USER GUIDE	290J851310
001T	U		USER GUIDE ST-17 ENG.	290J851250
Z001	F,K KK,U		UNIT KIT,RC-17ST REMOTE CONTROL	ZK290J0010
Z002			ANT COIL,AM LOOP	LA00055010
Z003			CONNECTIVE CORD,RCA ST.CORD 1M GOLD	ZD01000550
Z004	F,U		EXT.ANTENNA,EXT FM ANT	ZA02000070
Z004	K,KK, /02		EXT.ANTENNA,EXT FM ANT 931222R MAYOR	ZA02800020
Z005	F,U		PLUG,ANT ADAPTOR	YP90000310
Z006			CONNECTIVE CORD,RCA RC-5 CORD 0.9M ORANGE	ZD00900100
▲ Z007	K		JACK, AC ADAPTER SMK S-I6116	YJ04001240

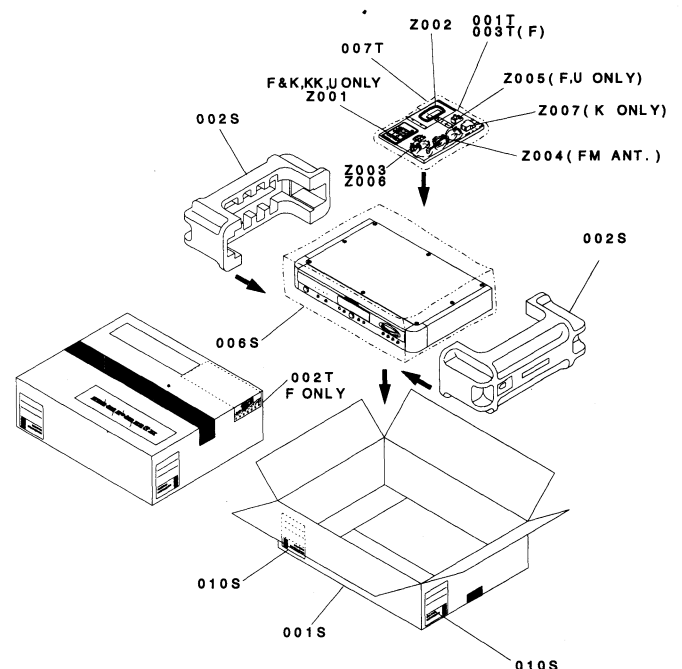

5. SERVICE PROGRAM

5-1. Tracking point memory mode

While holding the "MEMO" + "BAND" Buttons together (Press and hold the MEMO Button first), press the "MONO" Button to recall tracking point frequencies as shown below. (User programmed frequencies will be deleted.)

Tracking point frequencies

Version	P1~P3	P4	P5	P6	MHz
F	76.0	78.0	83.0	88.0	
U,K,KK,/02	87.5	90.0	98.0	106.0	

Version	P7	P8	P9	P10	P11	P12	P13	kHz
F	603	999	1404	531	531	531	531	
U	600	1000	1400	520	520	520	520	
K,KK,/02 LW Not used	603	999	1404	531	531	531	531	
K,KK,/02 LW Used	603	999	1404	171	207	270	152	

All of P14 to P60 are cleared.

Table-1 表1

[REMARK]

How to clear preset memories;

While holding the "MEMO" + "BAND" Buttons together (Press hold the MEMO Button first), press the "TUNING" Button.

The FL display shows "CLEAR" and preset memories are cleared.

5-2. Segment check mode

1) While holding the "MEMO" + "BAND" Buttons together (Press and hold the MEMO Button first), press the "DISPLAY" Button.

The FL display shows "FL CHECK", two seconds. After that all segments turn off, then the segments light one by one in sequence the "Sa" segment to "S16" segment at a rate of 0.3 second per segment. Finally all segments are turned on 3 seconds and the segment check mode finish. (The band and frequency will be returned previous status which had selected before segment check mode.)

2) When all the segments are lit, they remain lit for 3 seconds and the segment check mode completes. (The band and frequency selected immediately before the segment check mode are recalled.)

3) If the "MEMO" Button is pressed while all the segments are turned on, it will be returned previous status and then remain it be lit continuously. If the other operation Button is pressed (Which has related display indication ; ex. TUNING), the FL display shows normal indication occurs only for 5 seconds, after that all the segments light up again.

[REMARK]

The segment check mode can be released by turning the mains power off.

5-3. Local oscillator oscillation check

- 1) While holding the "MEMO" + "BAND" Buttons together (Press and hold the MEMO Button first), press the "CHAR" or "ST NAME" Button.
- 2) The FL display shows "SERVICE" for 2 seconds, after that some of the messages listed in the table will be shown. The displayed message makes it possible to check the oscillation of the local oscillators for the FM/AM (MW, LW) bands and the status of the data bus line between the microprocessor and PLL IC.

Displayed Message	Description
TUNER OK	All of the data bus and the FM and AM (MW, LW) local oscillators are OK.
TUNER NG	The data bus is OK, but the FM and AM (MW, LW) local oscillators are NG.
FM MW NG	The data bus and the LW local oscillator are OK, but the FM and MW local oscillators are NG. (When the LW is used)
FM LW NG	The data bus and the MW local oscillator are OK, but the FM and LW local oscillators are NG. (When the LW is used)
MW LW NG	The data bus and the FM local oscillator are OK, but the MW and LW local oscillators are NG. (When the LW is used)
FM NG	The data bus and the AM (MW, LW) local oscillator are OK, but the FM local oscillator is NG.
AM NG	The data bus and FM local oscillator are OK, but the AM local oscillator is NG. (When the LW is not used)
MW NG	The data bus and the FM and LW local oscillators are OK, but the MW local oscillator is NG. (When the LW is used)
LW NG	The data bus and the FM and MW local oscillators are OK, but the LW local oscillator is NG. (When the LW is used)
PLL NG	The data bus line or the PLL IC operation is NG.

Table-2 表2

[REMARK]

The "TUNER OK" message is shown for 2 seconds, after that the service mode will be finish automatically.

Other message listed in the table (Error messages) blinks until any Button is pressed, and the service mode will be finish when a Button is pressed. (Even when the defect is repaired while the message is blinking, present error message will not change to the "TUNER OK" message.)

サービスプログラム

1. トラッキングポイントメモリーモード

「MEMO」 + 「BAND」 ボタンを同時に押しながら（但し「MEMO」ボタンを先に押す）「MONO」ボタンを押すと Tracking point 周波数が表 1 の様にメモリーされます。（前データがある場合はオーバーライトされる）

【注意】プリセットメモリーのクリヤーの方法

「MEMO」 + 「BAND」 ボタンを同時に押しながら（但し「MEMO」ボタンを先に押す）「TUNING」ボタンを押します。FLに"CLEAR"と表示されプリセットメモリーがクリヤーされます。

2. セグメントチェックモード

- 1) 「MEMO」 + 「BAND」 ボタンを同時に押しながら（但し「MEMO」ボタンを先に押す）「DISPLAY」ボタンを押します。"FL CHECK"とFLに2秒間点灯表示した後、一旦、全消灯し全桁同時に「Sa」セグメントから順番に「S16」セグメントまで、0.3秒/セグメントのスピードで順次点灯します。
- 2) 全セグメントが点灯するとそのまま3秒間点灯した後、セグメントチェックモードを完了します。
(BAND及び周波数は、セグメントチェックモードの直前に戻ります。)

- 3) 3秒間点灯中に「MEMO」ボタンを押すと一旦通常表示状態になり、その後全セグメントが点灯したままの状態をそのまま継続します。
その後、表示内容を変更するようなボタン操作（例えば選局）を行なうと5秒間だけ通常の表示をした後、全セグメント点灯に戻ります。
電源をOFFすると解除します。

3. ローカルオシレーター回路の発振チェック

- 1) 「MEMO」ボタンと「BAND」ボタンを同時に押しながら（但し「MEMO」ボタンを先に押す）「ST NAME」ボタンを押します。
- 2) "SERVICE"と2秒間表示した後、表2のうちいずれかが表示されFM/AM(MW,LW)各バンドのローカルオシレータの発振状態、マイコンとPLLIC間のデータバスラインの状態が確認できます。

"TUNER OK"は2秒間表示され自動的にサービスモードを終了します。

それ以外の"NG"表示はボタン（どれでも可）を押すまで点滅し、ボタンを押すとサービスモードを終了します。（点滅中に不良箇所を直しても"TUNER OK"表示にはなりません）

6. TUNER ALIGNMENT PROCEDURES

- Set to Tracking point memory mode of the service program. (P4) to (P12) in the Digital Readout Frequency Setting column shows preset numbers for the above mode.
- Before alignment, connect a dummy resistor of 47 kohms to the output terminal.

6-1. FM Alignment Procedures

FM RF Alignment

(Band switch at "FM" position and MONO switch at "ON" position)

(Antenna selector switch at "A" position and IF BAND selector switch at "WIDE" position)

Step	Signal Source Connection	Signal Frequency	Indicator Connection	Digital Readout Frequency Setting	Adjust
1	FM signal generator 500 μ V output to FM antenna terminal (75-ohm).	98.0 MHz (83MHz)	DC VTVM to testpoint TP1 and TP2 (R254)	98.0 MHz (P5)	With L251 set the tuning voltage to 0V.
2			Distortion meter to L- or R-channel output	83 MHz [F] (P5)	

TEST EQUIPMENT REQUIRED

- 1) AM/FM Signal Generator
- 2) Video Signal Generator
- 3) Digital Multimeter
- 4) Distortion level meter

FM IF Alignment

(Band switch at "FM" position and MONO switch at "OFF" position)

Step	Signal Source Connection	Signal Frequency	Indicator Connection	Digital Readout Frequency Setting	Adjust
1	FM signal generator 500 μ V output modulated by MPX signal generator to FM antenna terminal (75-ohm).	Stereo L-channel (1.000 Hz)	VTVM to L-channel output (J301 L-channel)	98.0 MHz (P5)	Front end IFT for minimum distortion.
2	Modulation level: 67.5 kHz (L + R) [F,U] 6.75 kHz (PILOT) 40 kHz (L + R) [/02,K,KK] 6 kHz (PILOT)	Stereo R-channel (1.000 Hz)	VTVM to R-channel output (J301 R-channel)	83.0 MHz [F] (P5)	

Muting Level Alignment (WIDE)

(Band switch at "FM" position and MONO switch at "OFF" position IF BAND switch at "NARROW" position)

Step	Signal Source Connection	Signal Frequency	Indicator Connection	Digital Readout Frequency Setting	Adjust
1	FM signal generator 8.9 μ V output to FM antenna terminal (75-ohm)	98.0 MHz 83.0 MHz [F]	AC VTVM to L- or R-channel output (J301)	98.0 MHz (P5) 83.0 MHz [F] (P5)	R257 to a point at which output appears.

Muting Level Alignment (NARROW)

(Band switch at "FM" position and MONO switch at "OFF" position IF BAND switch at "NARROW" position)

Step	Signal Source Connection	Signal Frequency	Indicator Connection	Digital Readout Frequency Setting	Adjust
1	FM signal generator 8.9 μ V output to FM antenna terminal (75-ohm)	98.0 MHz 83.0 MHz [F]	AC VTVM to L- or R-channel output (J301)	98.0 MHz (P5) 83.0 MHz [F] (P5)	R218 to a point at which output appears.

Multiplex Alignment (WIDE)

(Band switch at "FM" position and MONO switch at "OFF" position IF BAND switch at "WIDE" position)

Step	Signal Source Connection	Signal Frequency	Indicator Connection	Digital Readout Frequency Setting	Adjust
1	FM signal generator 500 μ V output modulated by MPX signal generator to FM antenna terminal (75-ohm)	Stereo L-channel (1.000 Hz)	VTVM to R-channel output (J301 R-channel)	98.0 MHz (P5)	R303 so that channel separation is identical between both channels.
2	Modulation level : 67.5 kHz (L + R) [F,U] 6.75 kHz (PILOT) 40 kHz (L + R) [/02,K,KK] 6 kHz (PILOT)	Stereo R-channel (1.000 Hz)	VTVM to L-channel output (J301 L-channel)	83.0 MHz [F] (P5)	

Multiplex Alignment (NARROW)

(Band switch at "FM" position and MONO switch at "OFF" position IF BAND switch at "NARROW" position)

Step	Signal Source Connection	Signal Frequency	Indicator Connection	Digital Readout Frequency Setting	Adjust
1	FM signal generator 500 μ V output modulated by MPX signal generator to FM antenna terminal (75-ohm)	Stereo L-channel (1.000 Hz)	VTVM to R-channel output (J301 R-channel)	98.0 MHz (P5)	R343 so that channel separation is identical between both channels.
2	Modulation level : 67.5 kHz (L + R) [F,U] 6.75 kHz (PILOT) 40 kHz (L + R) [/02,K,KK] 6 kHz (PILOT)	Stereo R-channel (1.000 Hz)	VTVM to L-channel output (J301 L-channel)	83.0 MHz [F] (P5)	

6-2. AM (MW) Alignment Procedures

(Band switch at "AM" position)

AM IF Alignment

Step	Signal Source Connection	Signal Frequency	Indicator Connection	Digital Readout Frequency Setting	Adjust
1	Sweep generator to AM antenna terminal.	450 kHz	AC VTVM to L- or Rchannel output (J301)	—	LA06 LA52 for maximum and symmetrical waveform. LA52 [F] only

AM (MW) RF Alignment

Step	Signal Source Connection	Signal Frequency	Indicator Connection	Digital Readout Frequency Setting	Adjust
1	AM signal generator to AM loop antenna in a test loop.	603 kHz	AC VTVM to L- or R-channel output (J301)	603 kHz (P7)	LA01 for maximum output.
2		1404 kHz		1404 kHz (P9)	CA01 for maximum output.

LW RF Alignment [/02] ONLY

Step	Signal Source Connection	Signal Frequency	Indicator Connection	Digital Readout Frequency Setting	Adjust
1	AM signal generator to AM loop antenna in a test loop.	171 kHz	AC VTVM to L- or R-channel output (J301)	171 kHz (P10)	LA03 for maximum output.
2		270 kHz		270 kHz (P12)	CA08 for maximum output.

AM Stereo 調整 [F仕向] ONLY

手順	信号発振器の接続	発信周波数	測定器の接続	発信周波数	調整箇所
1	テストループを使いAM信号発振器からAMループアンテナに信号を加えます。 (50mV/m) 変調レベル： 400 Hz (L-R) = 80% 25 Hz PILOT = OFF	999kHz	左又は右チャンネル出力に交流VTVMを接続します。 (J301)	999kHz (P8)	セットのL-CH(又はR-CH)の出力が最小になるようにLA06,LA52,LA51を調整します。

7. ALIGNMENT AND TEST POINT

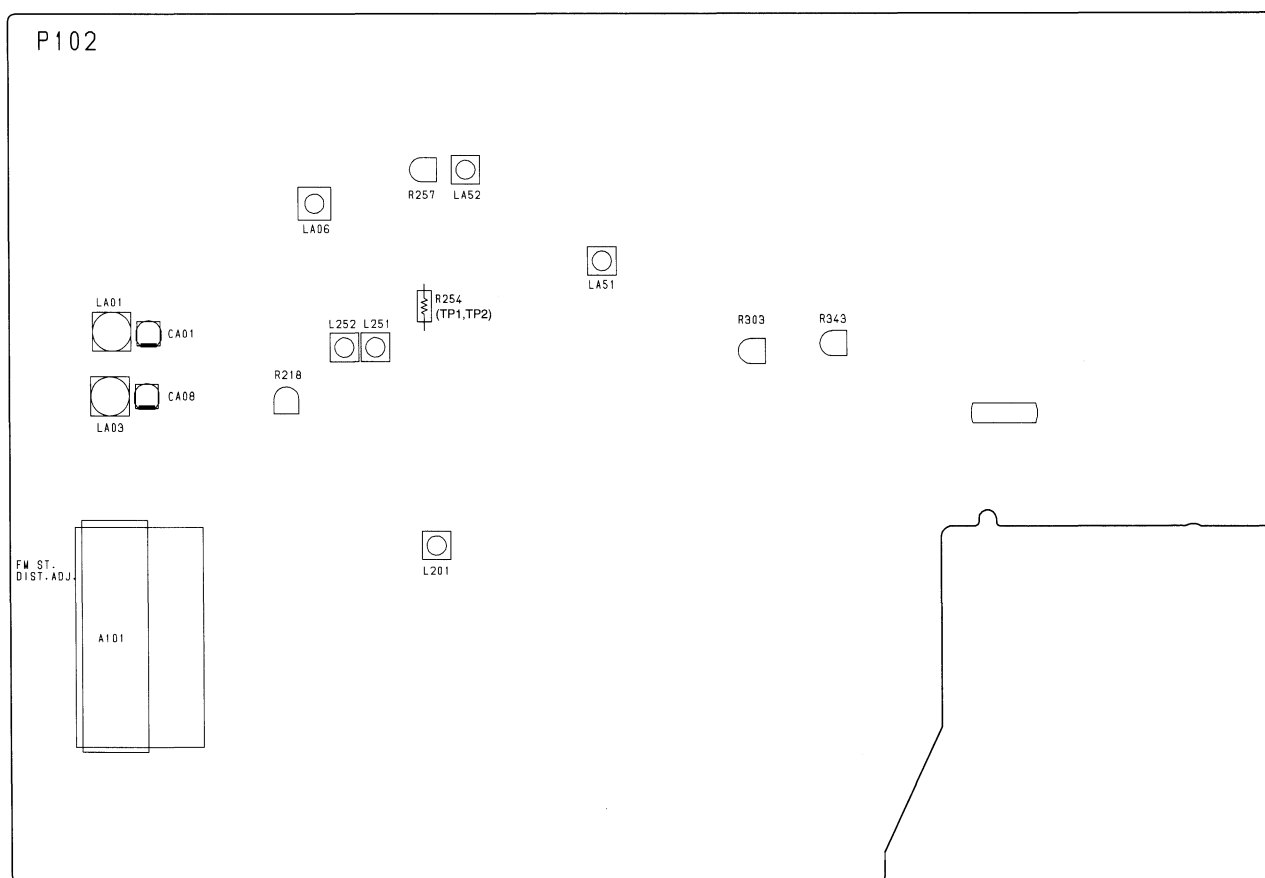

8. MICROPROCESSOR SPECIFICATIONS

		Receiving Frequency 受信周波数	Channel Space チャンネルスペース	Reference Frequency 基準周波数	Intermediate Frequency 中間周波数
F	FM	76.0 ~ 90.0MHz	100kHz	25kHz	-10MHz
	AM	531 ~ 1602kHz	9kHz	9kHz	+450kHz
U	FM	87.50 ~ 108.00MHz	50kHz	25kHz	+10.7MHz
	AM	520 ~ 1710kHz	10kHz	10kHz	+450kHz
/02 K, KK	FM	87.50 ~ 108.00MHz	50kHz	25kHz	+10.7kHz
	MW	531 ~ 1602kHz	9kHz	9kHz	+450kHz
	LW	152 ~ 280kHz	1kHz	1kHz	+450kHz



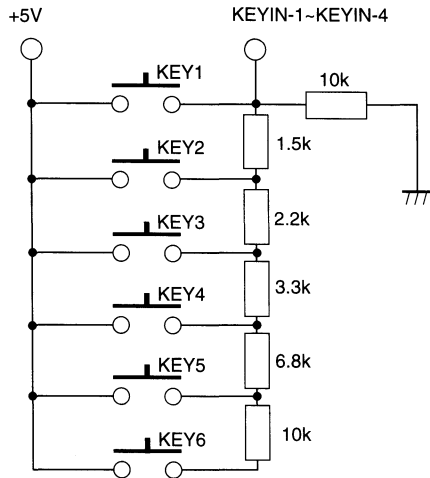

Key Matrix



KEY NO.	KEY IN VOLTAGE	CONPALATOR VOLTAGE	
		LOWER	UPPER
1	5.00V	4.77V Over	
2	4.35V	4.06V	4.69V
3	3.65V	3.44V	3.98V
4	2.94V	2.58V	3.36V
5	2.10V	1.80V	2.50V
6	1.48V	1.25V	1.72V

QS01 : TMP87CM71F

Pin no.	Port	Function	In/Out	Active	Specification	Pin no.	Port	Function	In/Out	Active	Specification
1	P10	INT0				41	P67	G8	OUT	H	2G
2	P11	INT1	IN	L	POWER OFF IN	42	P70	G7	OUT	H	3G
3	P12	INT2/TC1				43	P71	G6	OUT	H	4G
4	P13	DV0				44	P72	G5	OUT	H	5G
5	P14		OUT	L	TUNED	45	P73	G4	OUT	H	6G
6	P15	TC2				46	P74	G3	OUT	H	7G
7	P16		OUT	H	RC INT	47	P75	G2	OUT	H	8G
8	P17		OUT	H	RC EXT	48	P76	G1	OUT	H	9G
9	TEST	TEST				49	P77	G0	OUT	H	10G
10	P21	XT IN				50	P80	S0	OUT	H	Sr
11	P22	XT OUT				51	P81	A1	OUT	H	Sp
12	RESET		IN	L	RESET	52	P82	S2	OUT	H	An
13	X IN	X IN			XTAL (8.0MHz)	53	P83	A3	OUT	H	Am
14	X OUT	X OUT			XTAL	54	P84	S4	OUT	H	Sk
15	VSS	VSS			VSS	55	P85	S5	OUT	H	Sj
16	P20	INT5/STOP	IN	L	HOLD POWER DOWN	56	P86	S6	OUT	H	Sh
17	P30	INT3/TC3	IN		RC-5 BUS	57	P87	OUT	OUT	H	Sd
18	P31	TC4				58	P90	S8	OUT	H	Sc
19	P32	SCK	OUT		CLOCK	59	P91	S9	OUT	H	Se
20	P33	SI	IN		DATA1 IN (FROM DO LC7218)	60	P92	S10	OUT	H	Sg
21	P34	SO	OUT		DATA OUT (TO LC7218/LC72720)	61	P93	S11	OUT	H	Sf
22	P35	HSCK				62	P94	S12	OUT	H	Sb
23	P36		OUT	H	CE OUT (TO LC7218/LC72720)	63	P95	S13	OUT	H	Sa
24	P37	HSO	IN		DATA2 IN (FROM LC72720)	64	P96	S14	OUT	H	S15
25	P00					65	P97	S15	OUT	H	S16
26	P01					66	VKK	VKK			
27	P02					67	P40	KEY0	IN	H	JAPAN
28	P03		IN		LSD IN	68	P41	KEY1	IN	H	AM STEREO
29	P04					69	P42	KEY2	IN	L	LW
30	P05		OUT		ANT A/B (ANT)	70	P43	KEY3	IN	H	STANDBY
31	P06		OUT		IF BAND OUT (WIDE)	71	P44	KEY4	IN	L	AUTO/MANU
32	P07		OUT	L	MUTE	72	P45	KEY5			
33	VDD	VDD			VDD	73	P46	CIN5/KEY6			
34	P60	G15	OUT	H	NARROW LED OUT	74	P47	CIN4/KEY7			
35	P61	G14	OUT	H	WIDE LED OUT	75	P50	CIN3	IN		KEY4
36	P62	G13	OUT	H	ANT B LED OUT	76	P51	CIN2	IN		KEY3
37	P63	G12	OUT	H	ANT A LED OUT	77	P52	CIN1	IN		KEY2
38	P64	G11	OUT	L	STANDBY LED OUT	78	P53	CIN0	IN		KEY1
39	P65	G10	OUT	H	LED OUT	79	P54		IN		GYRO B
40	P66	G9	OUT	H	1G	80	P55	PWM/PDO	IN		GYRO A

JAPAN : 
 AM STEREO : 
 EUROPE LW : 
 AUTO/MANU switch : 
 STANDBY switch : 

Input terminals for initial setting SWs

*** PLL IC port description (PLL IC: LC7218)**

- OUT0 : MUTE signal output terminal (Active:[L])
- OUT1 : MONO signal output terminal (Active:[H])
- OUT2 : STRQ signal output terminal (Active: [H])
- OUT3 : STEREO CONT. signal output terminal (Active: [L])
Outputs the forced monaural signal for the AM stereo decoder.
- OUT4 : MW (AM) band switching signal output terminal (Active: [L])
- OUT5 : FM band switching signal output terminal (Active: [L])
- OUT6 : LW band switching signal output terminal (Active: [L]) or AM AGC CONT. signal output terminal (Note: Only when the initial setting is EUROPE LW = Not used).

Initial Setting SW	Level at Each Port	
	LOW (0V)	HI (5V)
JAPAN	Europe or USA	Japan
AM STEREO	Not used	Used
EUROPE LW	Used	Not used
AUTO/MANU	Used	Not used
STANDBY	Not used	Used

Europe or USA (LC7218 IN1 = Pin 8)	LOW	HI
	Europe (MW 9 kHz)	USA (AM 10 kHz)

Note: This terminal is disabled when the Japan destination is selected.

			Port Output			
			BAND Position			
			FM	MW (AM)		LW
With	With out					
Port No.	Port Name					
OUT0	9	MUTE	1/0	1/0	1/0	1/0
OUT1	10	MONO	1/0	1/0	0	0
OUT2	11	STRQ	1/0	1/0	1/0	1/0
OUT3	12	ST CON	1	1/0	1	1
OUT4	13	MW	1	0	0	1
OUT5	14	FM	0	1	1	1
OUT6	17	LW/AM AGC	1	1/0	1/0	0

FTD INDICATOR

Terminal Name	Pin No.	10G	9G	8G	7G	6G	5G	4G	3G	2G	1G
Sa	13	a	(3)	a	a	a	a	a	a	a	a
Sb	12	b	(2)	b	b	b	b	b	b	b	b
Sc	8	c	STEREO	c	c	c	c	c	c	c	c
Sd	7	d	MONO	d	d	d	d	d	d	d	d
Se	9	e	(MUTING)	e	e	e	e	e	e	e	
Sf	11	f	(1)	f	f	f	f	f	f	f	f
Sg	10	g	(TIMER)	g	g	g	g	g	g	g	g
Sh	6	h	TUNING	h	h	h	h	h	h	h	h
Sj	5	j	AUTO	j	j	j	j	j	j	j	j
Sk	4	k	-	k	k	k	k	k	k	k	k
Sm	3	m	-	m	m	m	m	m	m	m	m
Sn	2	n	-	n	n	n	n	n	n	n	n
Sp	63	p	-	p	p	p	p	p	p	p	p
Sr	62	r	-	r	r	r	r	r	r	r	r
S15	61	PRESET	TUNED	-	-	-	-	-	Dp	-	MHz
S16	60	MEMORY	-	-	-	-	-	-	-	-	kHz

9. ELECTRICAL PARTS LIST

ASSIGNMENT OF COMMON PARTS CODES.

RESISTORS

R * * * : 1) GD05 x x x 140, Carbon film fixed resistor, ±5% 1/4W
 R * * * : 2) GD05 x x x 160, Carbon film fixed resistor, ±5% 1/6W
 ① Resistance value

Examples

① Resistance value
 0.1 Ω 001 10 Ω 100 1k Ω.. 102 100k Ω 104
 0.5 Ω 005 18 Ω 180 2.7k Ω.. 272 680k Ω 684
 1 Ω 010 100 Ω 101 10k Ω.. 103 1M Ω 105
 6.8 Ω 068 390 Ω 391 22k Ω.. 223 4.7M Ω 475

Note : Please distinguish 1/4W from 1/6W by the shape of parts used actually.

CAPACITORS

C * * * : CERAMIC CAP.

3) DD1 x x x 370, Ceramic capacitor
 Disc type
 Temp.coeff. P350~N1000, 50V
 ③ Capacity value
 ② Tolerance

Examples

② Tolerance (Capacity deviation)

± 0.25 pF 0
 ± 0.5 pF 1
 ± 5 % 5

* Tolerance of COMMON PARTS handled here are as follows :

0.5 pF - 5 pF ± 0.25 pF
 6 pF - 10 pF ± 0.5 pF
 12 pF - 560 pF ... ± 5 %

③ Capacity value

0.5 pF 005 3 pF 030 100 pF 101
 1 pF 010 10 pF 100 220 pF 221
 1.5 pF 015 47 pF 470 560 pF 561

C * * * : CERAMIC CAP.

4) DK16 x x x 300, High dielectric constant ceramic capacitor
 Disc type
 Temp.chara. 2B4, 50V
 ④ Capacity value

Examples

④ Capacity value

100 pF 101 1000 pF 102 10000 pF 103
 470 pF 471 2200 pF 222

C * * * : 5) ELECTROLY CAP. (, 6) FILM CAP ()

5) EA x x x x x 10, Electrolytic capacitor
 One-way lead type, Tolerance ±20%
 ⑥ Working voltage
 ⑤ Capacity value

Examples

⑤ Capacity value

0.1 μ F 104 4.7 μ F 475 100 μ F 107
 0.33 μ F 334 10 μ F 106 330 μ F 337
 1 μ F 105 22 μ F 226 1100 μ F 118
 2200 μ F 228

⑥ Working voltage

6.3 V. . .006 25 V. . .025
 10 V. . .010 35 V. . .035
 16 V. . .016 50 V. . .050

6) DF15 x x x 350 → Plastic film capacitor
 DF15 x x x 310 → One-way type, Mylar ±5% 50V
 DF16 x x x 310 → Plastic film capacitor
 One-way type, Mylar ±10% 50V
 ⑦ Capacity value

Examples

⑦ Capacity value

0.001 μ F (1000pF) 102 0.1 μ F 104
 0.0018 μ F 182 0.56 μ F 564
 0.01 μ F 103 1 μ F 105
 0.015 μ F 153

NOTE : 1) The above CODES (R * * * , R * * * , C * * * , C * * * and C * * *) are omitted on the schematic diagram in some case.

2) On the occasion, be confirmed the common parts on the parts list.

3) Refer to "Common Parts List" for the other common parts (RI05, DD4, DK4).

NOTE ON SAFETY FOR FUSIBLE RESISTOR :

The suppliers and their type numbers of fusible resistors are as follows ;

1. KOA Corporation

Part No.(MJI)	Type No.(KOA)	Description
NH05 x x x 140	RF25S x x x x Ω J	(±5% 1/4W)
NH05 x x x 120	RF50S x x x x Ω J	(±5% 1/2W)
NH85 x x x 110	RF73B2A x x x x Ω J	(±5% 1/10W)
NH95 x x x 140	RF73B2E x x x x Ω J	(±5% 1/4W)

* Resistance value

Resistance value(0.1 Ω- 10k Ω)

2. Matsushita Electronic Components Co., Ltd

Part No.(MJI)	Type No.(MEC)	Description
NF05 x x x 140	ERD-2FCJ x x x	(±5% 1/4W)
RF05 x x x 140		
NF02 x x x 140	ERD-2FCG x x x	(±2% 1/4W)
RF02 x x x 140		

* Resistance value



Examples

* Resistance value
 0.1 Ω 001 10 Ω 100 1k Ω.. 102 100k Ω 104
 0.5 Ω 005 18 Ω 180 2.7k Ω.. 272 680k Ω 684
 1 Ω 010 100 Ω 101 10k Ω.. 103 1M Ω 105
 6.8 Ω 068 390 Ω 391 22k Ω.. 223 4.7M Ω 475

ABBREVIATION AND MARKS

ANT. : ANTENNA	BATT. : BATTERY
CAP. : CAPACITOR	CER. : CERAMIC
CONN. : CONNECTING	DIG. : DIGITAL
HP : HEADPHONE	MIC. : MICROPHONE
μ -PRO : MICROPROCESSOR	REC. : RECORDING
RES. : RESISTOR	SPK : SPEAKER
SW : SWITCH	TRANSF. : TRANSFORMER
TRIM. : TRIMMING	TRS. : TRANSISTOR
VAR. : VARIABLE	X ' TAL : CRYSTAL

NOTE ON SAFETY:

Symbol  Fire or electrical shock hazard. Only original parts should be used to replaced any part marked with symbol  Any other component substitution (other than original type), may increase risk of fire or electrical shock hazard.

安全上の注意 :

 がついている部品は、安全上重要な部品です。必ず指定されている部品番号の部品を使用して下さい。

POS. NO	VERS. COLOR	PART NO. (FOR PCS)	DESCRIPTION	PART NO. (MJI)	POS. NO	VERS. COLOR	PART NO. (FOR PCS)	DESCRIPTION	PART NO. (MJI)
CG51		4822 122 40586	PG02-GYRO CIRCUIT BOARD CER. CAP. 10000pF ±20%	DA17103110	CA04		4822 122 32027	CER. 56pF ±5% 50V	DD15560300
QG51		4822 130 11143	PHOTO UNIT GP1A06 2PHASE PHOTOINTERRUPTER	HW10033320	CA05		4822 121 42466	FILM 390pF ±5% 100V	DF15391550
			PS02-μ-COM CIRCUIT BOARD		CA06		4822 122 40586	CER. 0.01μF ±20% 25V	DA17103110
			PS02-CAPACITORS		CA07	/02	4822 122 40586	CER. 10000pF ±20%	DA17103110
CG52		4822 126 10364	CER. 100pF ±10%	DA16101110	CA08	/02	4822 125 50384	TRIMMING 20pF	CT12000200
CG53		4822 126 10364	CER. 100pF ±10%	DA16101110	CA09	/02	4822 122 31823	CER. 15pF ±5% 50V	DD15150300
CG54		4822 124 80087	ELECT 220μF 6.3V	EJ22700610	CA10		4822 124 90352	ELECT. 10μF ±20% 16V	OA10601620
CS01		4822 126 10935	ELECT 100μF 6.3V	EJ10700610	CA11	/02	4822 122 31349	CER. 68pF ±5% 50V	DD15680300
CS02		4822 122 40586	CER. 10000pF ±20%	DA17103110	CA12	/02	4822 122 10367	CER. 150pF ±5% 50V	DD15151300
CS03		4822 124 90406	BIG ELECT 0.22F	EX22300530	CA13	/02	4822 122 40586	CER. 10000pF ±20%	DA17103110
CS04		4822 124 80087	ELECT 220μF 6.3V	EJ22700610	CA14	/02	4822 122 40586	CER. 10000pF ±20%	DA17103110
CS05	F, KK /02, U	4822 126 10935	ELECT 100μF 6.3V	EJ10700610	CA15		4822 122 40586	CER. 10000pF ±20%	DA17103110
CS06		4822 122 40586	CER. 10000pF ±20%	DA17103110	CA16		4822 122 40588	CER. 0.022μF ±20%	DA17223110
CS07		4822 122 40586	CER. 10000pF ±20%	DA17103110	CA17		4822 124 41543	ELECT 1μF ±20% 50V	OA10505020
CS09		4822 122 40586	CER. 10000pF ±20%	DA17103110	CA18		4822 124 41543	ELECT 1μF ±20% 50V	OA10505020
CS10		4822 124 23053	ELECT 1μF 50V	EJ10505010	CA20		4822 124 90351	ELECT 0.1μF ±20% 50V	OA10405020
CS11		4822 122 40586	CER. 10000pF ±20%	DA17103110	CA21		4822 126 10363	CER. 68pF ±5% 50V	DA15680110
CS12		4822 122 40586	CER. 10000pF ±20%	DA17103110	CA22		4822 122 40586	CER. 10000pF ±20%	DA17103110
			PS02-SEMICONDUCTORS		CA23		4822 124 90352	ELECT 10μF ±20% 16V	OA10601620
DS01		4822 130 82421	DIODE 1D3 1A 200V	HD20002710	CA24		4822 122 40586	CER. 10000pF ±20%	DA17103110
DS02		4822 130 82421	DIODE 1D3 1A 200V	HD20002710	CA25		4822 124 90352	ELECT 10μF ±20% 16V	OA10601620
DS03					CA27		4822 124 90352	ELECT 10μF ±20% 16V	OA10601620
DS08		4822 130 32362	DIODE 1SS176 MA165 1SS254 30V 0.1A	HD20002000	CA28		4822 122 40586	CER. 10000pF ±20%	DA17103110
DS71					CA31		4822 122 40586	CER. 10000pF ±20%	DA17103110
DS74		4822 130 80326	L.E.D. LT3D8B RED	HI10062320	CA36		4822 122 40586	CER. 10000pF ±20%	DA17103110
QS01		4822 209 16174	MICROPROCESSOR TMP87CM71F	HU290JT02F	CA37		4822 122 33792	CER. 10pF ±5%	DA15100120
QS02		4822 130 42594	DIG.TR.S. DTC144ES UN4213	BA20002000	CA38		4822 122 40586	CER. 10000pF ±20%	DA17103110
QS03			PHOTO UNITRPM6936-V4	HW10004210	CA51	F	4822 122 33639	CER. 1000pF ±10% 50V	DA16102110
QS04		4822 130 61227	DIG.TR.S. DTA114ES UN4111	BA10001000	CA53	F	4822 124 90352	ELECT. 10μF ±20% 16V	OA10601620
QS05		4822 130 42594	DIG.TR.S. DTC144ES UN4213	BA20002000	CA54	F	4822 124 90352	ELECT. 10μF ±20% 16V	OA10601620
			PS02-MISCELLANEOUS		CA55	F	4822 122 33639	CER. 1000pF ±10% 50V	DA16102110
SS01		4822 276 20508	PUSH SW. MEMO	SP01011280	CA56	F	4822 122 40588	CER. 0.022μF ±20% 25V	DA17223110
SS02		4822 276 20508	PUSH SW. IF BAND	SP01011280	CA63	F	4822 124 22273	ELECT 0.47μF ±20% 50V	OA47405020
SS03		4822 276 20508	PUSH SW. ANTENNA A B	SP01011280	CA64	F	4822 124 90352	ELECT. 10μF ±20% 16V	OA10601620
SS11		4822 276 20508	PUSH SW. BAND	SP01011280	CA66	F	4822 122 40586	CER. 10000pF ±20%	DA17103110
SS12		4822 276 20508	PUSH SW. AUTO MANU	SP01011280	CA67	F	4822 122 31205	CER. 47pF ±5% 50V	DD15470300
SS21		4822 276 20508	PUSH SW. MONO ST	SP01011280	CA68	F	4822 124 41543	ELECT 1μF ±20% 50V	OA10505020
SS22		4822 276 20508	PUSH SW. TUNING	SP01011280	CA69	F	4822 124 90358	ELECT 22μF ±20% 16V	OA22601620
SS23		4822 276 20508	PUSH SW. PRESET	SP01011280	CA70	F	4822 124 41539	ELECT 47μF ±20% 16V	OA47601620
SS24	/02	4822 276 20508	PUSH SW. PTY	SP01011280	CA71	F	4822 122 33639	CER. 1000pF ±10% 50V	DA16102110
SS31		4822 276 20508	PUSH SW. DISPLAY RDS	SP01011280	CA72	F	4822 122 33639	CER. 1000pF ±10% 50V	DA16102110
SS32		4822 276 20508	PUSH SW. CHAR	SP01011280	CA73	F	4822 122 33639	CER. 1000pF ±10% 50V	DA16102110
VS01		4822 130 91282	DISPLAY UNIT FIP12BM8R	HQ31106060	CA75	F	4822 124 41543	ELECT 1μF ±20% 50V	OA10505020
XS01		4822 242 72066	SERAMVIB. CST8.0MHz MT	FQ08004010	CA76	F	4822 124 41543	ELECT 1μF ±20% 50V	OA10505020
			P102-TUNER CIRCUIT BOARD		CA78	F	4822 124 90354	ELECT 100μF ±20% 16V	OA10701620
			P102-CAPACITORS		CA79	F	4822 122 40586	CER. 0.01μF ±20% 25V	DA17103110
CA01		4822 125 50384	TRIMMING 20pF	CT12000200	CA80	F	4822 122 40586	CER. 0.01μF ±20% 25V	DA17103110
CA02		4822 122 40589	CER. 0.047μF ±20%	DA17473110	CA81	F	4822 122 40586	CER. 0.01μF ±20% 25V	DA17103110
CA03		4822 122 31823	CER. 15pF ±5% 50V	DD15150300	CH01			FILM 220pF ±5% 100V PP	OF15221540
					CH02			FILM 220pF ±5% 100V PP	OF15221540
					CH03		4822 124 22241	ELECT 47μF 16V	OA47601650
					CH04		4822 124 22241	ELECT 47μF 16V	OA47601650
					CH07		4822 124 22241	ELECT 47μF 16V	OA47601650
					CH08		4822 124 22241	ELECT 47μF 16V	OA47601650
					CH11		4822 124 23514	ELECT 100μF 16V	OA10701650
					CH12		4822 124 23514	ELECT 100μF 16V	OA10701650
					CH13		4822 124 22039	ELECT 220μF 16V	OA22701650
					CH14		4822 124 22039	ELECT 220μF 16V	OA22701650
					CH15		5322 122 32143	CER. 22pF ±5% 50V	DD15220300
					CH16		5322 122 32143	CER. 22pF ±5% 50V	DD15220300

POS. NO	VERS. COLOR	PART NO. (FOR PCS)	DESCRIPTION	PART NO. (MJI)	POS. NO	VERS. COLOR	PART NO. (FOR PCS)	DESCRIPTION	PART NO. (MJI)
C101		4822 122 33639	CER. 1000pF ±10% 50V	DA16102110	C361				
C102		4822 122 40586	CER. 10000pF ±20%	DA17103110	3	/02	4822 126 10364	CER. 100pF ±10%	DA16101110
C103		4822 122 33639	CER. 1000pF ±10%	DA16102110	C364				
C104		4822 122 40586	CER. 10000pF ±20%	DA17103110	C501		4822 122 31205	CER. 47pF ±5% 50V	DD15470300
C105		4822 122 33639	CER. 1000pF ±10%	DA16102110	C502		4822 122 31205	CER. 47pF ±5% 50V	DD15470300
C106					C503		4822 124 90354	ELECT 100μF ±20% 16V	OA10701620
3		4822 122 40586	CER. 10000pF ±20%	DA17103110	C504		4822 122 40586	CER. 0.01μF ±20% 25V	DA17103110
C110					C505		4822 124 90351	ELECT 0.1μF ±20% 50V	OA10405020
C120		4822 122 40586	CER. 10000pF ±20%	DA17103110	C506		4822 124 41543	ELECT 1μF ±20% 50V	OA10505020
C201					C507		4822 122 40586	CER. 0.01μF ±20% 25V	DA17103110
3		4822 122 40586	CER. 10000pF ±20%	DA17103110	C521		4822 122 40586	CER. 0.01μF ±20% 25V	DA17103110
C206					C522		4822 122 40586	CER. 0.01μF ±20% 25V	DA17103110
C207		4822 122 31349	CER. 68pF ±5% 50V	DD15680300	C523		4822 122 40586	CER. 0.01μF ±20% 25V	DA17103110
C208					C801		4822 122 30043	CER. 0.01μF +80%-20% 50V	DK18103310
3		4822 122 40586	CER. 10000pF ±20%	DA17103110	C802		4822 122 30043	CER. 0.01μF +80%-20% 50V	DK18103310
C216					C803			ELECT 1000μF 35V	OA10803550
C221	/02	4822 124 90352	ELECT 10μF ±20% 16V	OA10601620	C804			ELECT 1000μF 35V	OA10803550
C222	/02	4822 122 40586	CER. 10000pF ±20%	DA17103110	C805		4822 124 41539	ELECT 47μF ±20% 16V	OA47601620
C230		4822 122 40586	CER. 10000pF ±20%	DA17103110	C806		4822 124 41539	ELECT 47μF ±20% 16V	OA47601620
C231		4822 122 40586	CER. 10000pF ±20%	DA17103110	C807		4822 124 22241	ELECT 47μF 16V	OA47601650
C253		4822 122 40588	CER. 0.022μF ±20%	DA17223110	C808		4822 124 22241	ELECT 47μF 16V	OA47601650
C254		4822 122 40588	CER. 0.022μF ±20%	DA17223110	C809		4822 124 22695	ELECT 2200μF ±20% 35V	OA22803520
C255		4822 124 90352	ELECT 10μF ±20% 16V	OA10601620	C810		4822 124 41539	ELECT 47μF ±20% 16V	OA47601620
C256		4822 122 40588	CER. 0.022μF ±20%	DA17223110	C811		4822 122 30043	CER. 0.01μF +80%-20% 50V	DK18103310
C257		4822 124 90353	ELECT 100μF 10V	OA10701020	C812		4822 124 23913	ELECT 2200μF 16V	OA22801620
C258		4822 124 22273	ELECT 0.47μF ±20% 50V	OA47405020	C813		4822 124 90351	ELECT 0.1μF ±20% 50V	OA10405020
C259		5322 122 32336	FILM 560pF ±5% 50V	DF15561350	C814		4822 124 90354	ELECT 100μF ±20% 16V	OA10701620
C260		4822 126 10363	CER. 68 pF ±5% 50V	DA15680110	C815		4822 122 30043	CER. 0.01μF +80%-20% 50V	DK18103310
C261		4822 122 40588	CER. 0.022μF ±20%	DA17223110	C816		4822 124 90355	ELECT 100μF ±20% 50V	OA10705020
C262		4822 124 90354	ELECT 100μF ±20% 16V	OA10701620	C817		4822 124 90355	ELECT 100μF ±20% 50V	OA10705020
C264		4822 122 40588	CER. 0.022μF ±20%	DA17223110	C818		4822 122 30043	CER. 0.01μF +80%-20% 50V	DK18103310
C281		4822 122 40586	CER. 10000pF ±20%	DA17103110	C821		4822 122 40586	CER. 10000pF ±20%	DA17103110
C282		4822 122 40586	CER. 10000pF ±20%	DA17103110	C831		4822 124 41539	ELECT 47μF ±20% 16V	OA47601620
C283		4822 122 40586	CER. 10000pF ±20%	DA17103110	C841		4822 124 41539	ELECT 47μF ±20% 16V	OA47601620
C301		4822 124 90359	ELECT 22μF 16V	OA22601650	C842		4822 124 41539	ELECT 47μF ±20% 16V	OA47601620
C302		4822 124 23514	ELECT 100μF 16V	OA10701650	U025		4822 126 10364	CER. 100pF ±10%	DA16101110
C303		4822 122 33639	CER. 1000pF ±10% 50V	DA16102110				P102-CAPACITORS(COMMON)	
C305		4822 124 41543	ELECT 1μF ±20% 50V	OA10505020	C***			PLASTIC FILM CAPACITOR	
C306		4822 124 90352	ELECT 10μF ±20% 16V	OA10601620				±5% 50V : (CA19 [OTHER K])	
C307		4822 124 22696	ELECT 3.3μF ±20% 50V	OA33505020				(CA65 [F]) C304	
C308		4822 124 22273	ELECT 0.47μF ±20% 50V	OA47405020					
C309	F,K /02,U		FILM 470pF ±5% 100V	OF55471530	C***			HIGH DIELECTRIC CONSTANT	
C309	KK		FILM 560pF ±5% 100V	OF55681530				CERAMIC CAPACITOR ±10%	
C310	F,K /02,U		FILM 470pF ±5% 100V	OF55471530				50V : (CA57-CA62 [F])	
C310	KK		FILM 560pF ±5% 100V	OF55681530				(C317 C318[K])	
C315	/02		FILM 100pF ±5% 100V	OF55101530	RH19		4822 052 10101	100Ω ±5% 1/6W	GG05101160
C316	/02		FILM 100pF ±5% 100V	OF55101530	RH20		4822 052 10101	100Ω ±5% 1/6W	GG05101160
C319		4822 122 40586	CER. 0.01μF ±20% 25V	DA17103110	RH21		4822 052 10101	100Ω ±5% 1/6W	GG05101160
C323		4822 124 22039	ELECT 220μF 16V	OA22701650	RH22		4822 052 10101	100Ω ±5% 1/6W	GG05101160
C324		4822 124 22039	ELECT 220μF 16V	OA22701650	R218		4822 100 20681	2.2kΩ TRIMMING	RA02220780
C351	/02	4822 122 40586	CER. 10000pF ±20%	DA17103110	R257		4822 100 11471	100kΩ TRIMMING	RA01040780
C352	/02	4822 124 90352	ELECT 10μF ±20% 16V	OA10601620	R303		4822 100 11471	100kΩ TRIMMING	RA01040780
C353	/02	4822 126 11071	CER. 330pF ±10%	DA16331110	R343		4822 100 11641	470kΩ TRIMMING	RA04740780
C354	/02	4822 126 10409	CER. 560pF ±10%	DA16561110	▲ R801		4822 113 90107	4.7Ω ±5% 1/4W FUSIBLE	NH05047140
C355	/02	4822 122 40586	CER. 10000pF ±20%	DA17103110	▲ R802		4822 113 90107	4.7Ω ±5% 1/4W FUSIBLE	NH05047140
C356	/02	4822 122 31823	CER. 15pF ±5% 50V	DD15150300	▲ R803		4822 111 90967	4.7kΩ ±5% 1/4W FUSE	NF05047140
C357	/02	4822 122 31823	CER. 15pF ±5% 50V	DD15150300	▲ R804		4822 111 90967	4.7kΩ ±5% 1/4W FUSE	NF05047140
C358	/02	4822 124 90352	ELECT 10μF ±20% 16V	OA10601620	▲ R813		4822 050 26801	680Ω ±5% 1/4W	GG05681140
C359	/02	4822 124 90352	ELECT 10μF ±20% 16V	OA10601620	R846		4822 050 21022	1kΩ ±5% 1/4W	GG05102140
C360	/02	4822 122 33639	CER. 1000pF ±10%	DA16102110					

POS. NO	VERS. COLOR	PART NO. (FOR PCS)	DESCRIPTION	PART NO. (MJI)	POS. NO	VERS. COLOR	PART NO. (FOR PCS)	DESCRIPTION	PART NO. (MJI)	
R***			P102-RESISTORS (COMMON) CARBON FILM FIXED RES. ±5% 1/6W : DH11 DH12 RA01 RA02 (RA03 RA04 RA06-RA11 [02]) RA12-RA15 RA17 RA18 (RA19 RA20 [02]) RA21 (RA51 RA53-RA67 RA69-RA72 RA73-RA75 RA77 [F]) RG51-RG53 RH01-RH12 RH15-RH18 RH25-RH28 RH31-RH36 RH39 RH40 (RH41 RH42 [OTHER F]) RS10-RS13 RS20-RS23 RS30 RS32 RS41 (RS42 [02]) (RS63 RS65 [F,K, KK,U]) RS66 (RS71 RS72 [F]) (RS73 [F,K,KK,U,]) RS91-RS94 R101-R118 R201-R217 R219-R232 R251-R253 R255 (R258 [02]) R261 R262 R268 R273-R277 R280-R284 R286 R287 R301 R302 R304 R307-R310 R315-R326 (R327 R328 [F,K,KK,U,]) (R331 [K]) R341 R342 (R352 [02]) R501-R506 R521 R522 R805 R806 R814-R816 R830 R831 R833 R841 R843 R845		R***			CARBON FILM FIXED RES. ±5% 1/4W : (R233 [02]) R254		
			P102-SEMICONDUCTORS							
DA01		4822 125 50416	VARI SVC342-L	HD40009030	QA01	/02	4822 130 41947	TRS. 2SC536SP 2SC2458 2SC3311 2SC1740S	HT30001000	
DA02	/02	4822 130 33697	DIODE 1SS135	HD20017210	QA02	/02	4822 130 41947	TRS. 2SC536SP 2SC2458 2SC3311 2SC1740S	HT30001000	
DA03	/02	4822 125 50416	VARI SVC342-L	HD40009030	QA03	/02	4822 130 61892	TRS. 2SD2144S U V	HT421442A0	
DA04	/02	4822 130 33697	DIODE 1SS135	HD20017210	QA04		4822 130 61227	DIG.TRS. DTA114ES UN4111	BA10001000	
DA05		4822 130 32362	DIODE 1SS176 MA165 1SS254 30V 0.1A	HD20002000	QA05	/02	4822 130 60495	TRS. 2SA1309A Q R	HT113092C0	
DA06		4822 130 32362	DIODE 1SS176 MA165 1SS254 30V 0.1A	HD20002000	QA06	/02	4822 130 60495	TRS. 2SA1309A Q R	HT113092C0	
DH01					QA51	F		IC MC13022P AM STEREO	HC10078170	
∫					QA52	F	4822 130 41947	TRS. 2SC536SP 2SC2458	HT30001000	
DH10		4822 130 32362	DIODE 1SS176 MA165 1SS254 30V 0.1A	HD20002000	QA53	F	4822 130 42594	DIG.TRS. DTC144ES UN4213	BA20002000	
DH13		4822 130 32362	DIODE 1SS176 MA165 1SS254 30V 0.1A	HD20002000	QH03		4822 130 43233	TRS. 2SC2240 GR BL	HT322402A0	
DH14		4822 130 32362	DIODE 1SS176 MA165 1SS254 30V 0.1A	HD20002000	QH04		4822 130 43233	TRS. 2SC2240 GR BL	HT322402A0	
D101					QH05		4822 130 42949	TRS. 2SA970 GR BL	HT109702A0	
∫					QH08					
D111		4822 130 33697	DIODE 1SS135	HD20017210	QH09		4822 130 43233	TRS. 2SC2240 GR BL	HT322402A0	
D201					QH16		4822 130 42949	TRS. 2SA970 GR BL	HT109702A0	
∫					QH17		4822 130 42949	TRS. 2SA970 GR BL	HT109702A0	
D204		4822 130 33697	DIODE 1SS135	HD20017210	QH18		4822 130 42949	TRS. 2SA970 GR BL	HT109702A0	
D301		4822 130 32362	DIODE 1SS176 MA165 1SS254 30V 0.1A	HD20002000	Q201		4822 130 60495	TRS. 2SA1309A Q R	HT113092C0	
D302		4822 130 32362	DIODE 1SS176 MA165 1SS254 30V 0.1A	HD20002000	Q203		4822 130 62294	TRS. 2SC1809S P	HT318091P0	
▲ D801					∫					
∫					Q209		4822 209 71785	IC LA1266 FM AM IF	HC10222030	
▲ D804		4822 130 82421	DIODE 1D3 1A 200V	HD20002710	Q252	/02	4822 130 41947	TRS. 2SC536SP 2SC2458 2SC3311 2SC1740S	HT30001000	
▲ D810					Q258		4822 130 41947	TRS. 2SC536SP 2SC2458 2SC3311 2SC1740S	HT30001000	
∫					Q275		4822 130 60495	TRS. 2SA1309A Q R	HT113092C0	
▲ D814		4822 130 82421	DIODE 1D3 1A 200V	HD20002710	Q276		4822 130 60495	TRS. 2SA1309A Q R	HT113092C0	
▲ D815		4822 130 82474	ZENER DIODE RD20JB2 MTZJ20C	HD32001000	Q277		4822 130 41947	TRS. 2SC536SP 2SC2458 2SC3311 2SC1740S	HT30001000	
					Q281		4822 130 60495	TRS. 2SA1309A Q R	HT113092C0	
					Q282		4822 130 60495	TRS. 2SA1309A Q R	HT113092C0	
					Q283		4822 130 41947	TRS. 2SC536SP 2SC2458 2SC3311 2SC1740S	HT30001000	
					Q301		4822 209 70261	IC LA3410 FM MPX	HC10198030	
					Q303		4822 130 42594	DIG.TRS. DTC144ES UN4213	BA20002000	
					Q304		4822 130 61227	DIG.TRS. DTA114ES UN4111	BA10001000	
					Q305					
					∫		4822 130 43818	TRS. 2SC2878 A BRANK	HT328782A0	
					Q308					
					Q309	/02	4822 130 41947	TRS. 2SC536SP 2SC2458	HT30001000	
					Q341		4822 130 43818	TRS. 2SC2878 A BRANK	HT328782A0	

POS. NO	VERS. COLOR	PART NO. (FOR PCS)	DESCRIPTION	PART NO. (MJI)	POS. NO	VERS. COLOR	PART NO. (FOR PCS)	DESCRIPTION	PART NO. (MJI)
Q351	/02		IC LC72720 RDS DECODER	HC10385030	L301		4822 157 70021	M.P.X. COIL FM19 38 KHz	LS10293010
Q501		4822 209 30178	IC LC7218 PLL	HC10221030	L302		4822 157 70021	M.P.X. COIL FM19 38 KHz	LS10293010
Q502		4822 130 42121	F.E.T. 2SK30ATM Y1	HF200300B0	L350				
Q503		4822 130 41947	TRS. 2SC536SP 2SC2458 2SC3311 2SC1740S	HT30001000	}	/02	4822 157 62911	CHOKO COIL LAL02TA3R3J 3.3μH	LC13323800
▲ Q801		5322 130 41842	TRS. 2SD1827 +12V AF	HT418271A0	L359				
▲ Q802		4822 130 62704	TRS. 2SB1225 -12V AF	HT212251A0	S101		4822 277 21712	SLIDE SW. FM RF ATT	SS02021470
▲ Q807		4822 209 60826	IC NJM7812FA +12V 1A	HC38912090	S301	/02	4822 277 21712	SLIDE SW. 9K 10KHz DE.EMPHASIS	SS02021470
Q811		4822 209 70385	IC 78MR05 5V 0.5A REG.	HC10205030	XA51	F		SERAMVIB. CSA3.60MFG103	FQ03604020
Q830		4822 130 42594	DIG. TRS. DTC144ES UN4213	BA20002000	X301		4822 242 81117	SERAMVIB. CSB456F11 FOR LA3410	FQ04563010
Q831		4822 130 41947	TRS. 2SC536SP 2SC2458	HT30001000	X351	/02	4822 242 10857	CRYSTAL 4.332MHZ X.TAL FOR RDS DEMO IC	JX04003260
▲ Q841		4822 130 61892	TRS. 2SD2144 U OR V +8V	HT421442A0	X501		4822 242 72333	CRYSTAL 7.2MHZ	JX07001260
Q843		4822 130 41947	TRS. 2SC536SP 2SC2458	HT30001000					
A101	F		P102-MISCELLANEOUS VHF TUNER FM FRONT END FE407-J49	AV01201070				P802-TRANSF. CIRCUIT BOARD POWER TRANSFORMER (100V 50Hz 60Hz)	TS15743020
A101	K, KK /02, U	4822 210 10372	VHF TUNER FE415-G09	AV01202210	L801	F		POWER TRANSFORMER (115V 230V 50Hz)	TS15743030
FA01		4822 242 81262	CER. FILTER SFP450 F	FF10045390	▲ L801	K, U		POWER TRANSFORMER (115V 230V 50Hz)	TS15743010
F201	F, K KK, U	4822 242 72345	CER. FILTER SFE10.7MX2-A	FF11070660	▲ L801	KK, /02	4822 146 10932	POWER TRANSF. 230V 50HZ	TS15743010
F201	/02	4822 242 70911	CER. FILTER SFE10.7MA8-A	FF11070610				P852-POWER SW. CIRCUIT BOARD CER. CAP. 0.01μF ±20% 250V	DK17103840
F202	F, K KK, U	4822 242 70665	CER. FILTER SFE10.7MS3-A	FF11070620	▲ C851		4822 122 33276		DK17103840
F202	/02	4822 242 72346	CER. FILTER SFE10.7M22-A	FF11070670	▲ S851		4822 276 13364	PUSH POWER SW. SDDL1214A TV-3	SP01011990
F203		4822 242 70911	CER. FILTER SFE10.7MA8-A	FF11070610	▲ S852	/02	4822 277 21825	SLIDE SW. VOL. SEL. SDKGA4	SS02021510
F204		4822 242 72345	CER. FILTER SFE10.7MX2-A	FF11070660					
G501		4822 111 92204	COMPO. NETWORK 10kΩ x5	BW05103240					
J101	F, U	4822 264 10371	TERMINAL YKD31-0468 FM ANT F 1P	YT01010350					
J101	K, KK /02		TERMINAL YKD31-0442 FM ANT 1P	YT02011080					
J102	F, U	4822 290 81537	TERMINAL YKD31-0426 FM AM ANT F	YT01030080					
J102	K, KK /02	4822 290 81632	TERMINAL YKD31-0215A FM AM ANT PAL	YT03030020					
J301		4822 290 81598	TUNER OUTPUT TERMINAL L R GL	YT02021130					
LA01		4822 157 63084	AM ANT COIL	LA10295170					
LA02		4822 157 70779	AM OSC COIL	LO70013010					
LA03	/02	4822 157 52714	LW ANT COIL FOR LA1267	LA10295160					
LA04	/02	4822 157 70781	LW OSC COIL	LO70013020					
LA05		4822 157 53589	CHOKO COIL 39 MH	LC23960710					
LA06		4822 148 81095	I.F.T. COIL AM IFT	LI70033510					
LA51	F		I.F.T. COIL A7NRES-T1370Y 450KHz	LI71010120					
LA52	F	4822 148 81095	I.F.T. COIL AM IFT K7-H5	LI70033510					
L101	}	4822 157 62911	CHOKO COIL LAL02TA3R3J 3.3μH	LC13323800					
L106		4822 157 11493	I.F.T. COIL FM NAR.DIST IFT-41K7-H5	LI74018040					
L201		4822 157 11493	I.F.T. COIL FM NAR.DIST IFT-41K7-H5	LI74018040					
L251		4822 157 62408	I.F.T. FM DET COIL 134-5109-01	LI70379040					
L252		4822 157 62409	I.F.T. FM DET COIL 134-5110-01	LI70379050					
L253		4822 156 10794	M.P.X. COIL ANTIBIRDE FILTER	LS10295030					