

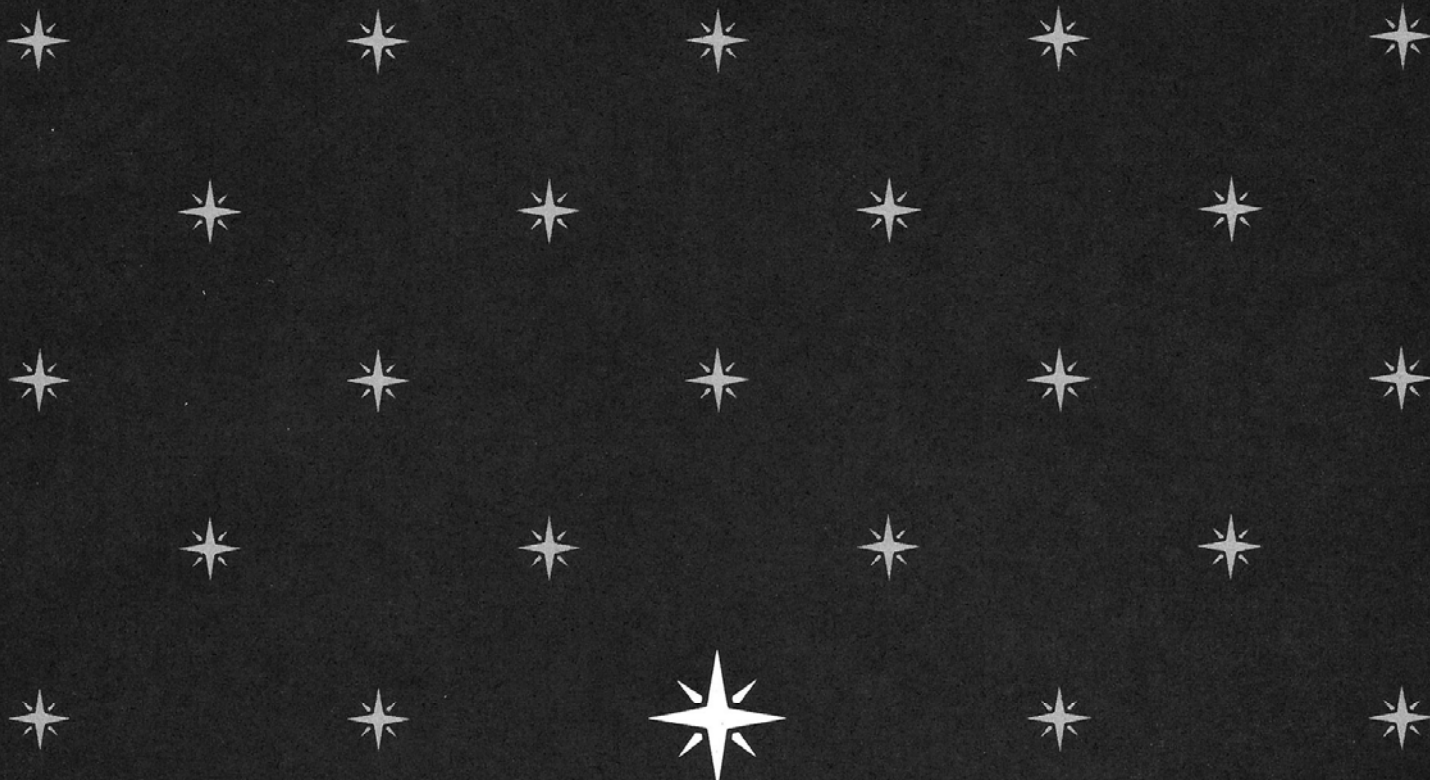

SERVICE **ST310**
MANUAL



marantz

model ST310

Stereophonic Tuner

MARANTZ DESIGN AND SERVICE

Using superior design and selected high grade components, MARANTZ Company has created the ultimate in stereo sound. Only original MARANTZ parts can insure that your MARANTZ product will continue to perform to the specifications for which it is famous.

Parts for your MARANTZ stereo are generally available within 72 hours throughout the nation via a toll-free line to our National Parts Depot in California. The sales professionals who take your call immediately refer to their own desk top computer terminal and can quickly determine the availability and price information you require. If for some reason, your order should exceed our available stock, we usually can instantly provide an alternate replacement part or current delivery information. When the order is placed and confirmed, the computer simultaneously generates "hard copy" orders at the distribution center. As hard copies come directly from the computer to the national parts depot, your requested stock is assembled and prepared for shipment and placed on the first available carrier for delivery to you.

ORDERING PARTS

Phone orders will eliminate mail delays, and we encourage the use of this method. If you order by mail, use MARANTZ parts order forms which are available from our National Parts Depot located at the following address:

SUPERSCOPE NATIONAL PARTS DEPARTMENT
20525 Nordhoff Street
Chatsworth, California 91311
Phone: 1-800-423-5108
1-213-998-9333

The following information must be supplied to eliminate delays in processing your order:

1. Complete address.
2. Complete part numbers.
3. Complete description of parts.
4. Model number for which part is required (indicate MARANTZ).
5. Account number (for account customers only).

Direct consumers will be provided with the current retail price quotation on available parts in order to advise them of the cost of the parts and shipping.

OVERSEAS PARTS ORDERING

Parts may also be ordered from the following overseas addresses:

CANADA

Superscope Canada, Ltd.
3710 Nashua Drive
Mississauga
Ontario, Canada L4V1M5

AUSTRALIA

Superscope (Australasia) Pty., Ltd.
32 Cross Street (P.O.Box 604)
Brookvale 2100 N.S.W.
Australia

JAPAN

Marantz Japan, Inc.
3622 Kamitsuruma
Sagamihara Shi
Kanagawa, Japan

EUROPE

Superscope Europe, S.A.
Avenue Leopold III, 2
7120 Peronnes-Lez-Binche
Belgium

Marantz France
Rue Louis Armand 9
92600 Asnieres
Hauts-de-Seine
France

Marantz Audio U.K. Ltd.
London Road, 203
Staines
Middlesex
England

Superscope GmbH
Max-Planck-Strass 22
D-6072 Dreieich
West Germany

All of the above locations are fully equipped to take care of your total service needs. Because various countries have differing configuration requirements, it is necessary that you contact the service facility in your particular country. In the event that there is no service location listed for your country, please contact the nearest facility for the necessary assistance.

marantz®
We sound better.

TABLE OF CONTENTS

SECTION	PAGE
1. INTRODUCTION	1
2. P.W. BOARDS	1
3. TEST EQUIPMENT REQUIRED SERVICING	2
4. ALIGNMENT PROCEDURES	2
4.1 FM Alignment Procedures (Selector switch in the "FM" position)	2.3
4.2 Muting Circuit Alignment	3
4.3 Multiplex Alignment Procedures (Selector switch in the "FM" position)	3
4.4 AM Alignment Procedures (Selector switch in the "AM" position)	4
5. VOLTAGE CONVERSION FOR EUROPEAN MODEL	5
6. BLOCK DIAGRAM	6
7. DIAGRAM AND COMPONENT LOCATIONS	7
7.1 Tuner Assembly (P100) Schematic Diagram and Component Locations	7
7.2 Func./Signal Strength LED Assembly (PX00) Schematic Diagram and Locations	9
8. EXPLODED VIEW AND PARTS LIST	10
9. ELECTRICAL PARTS LIST	15
10. TECHNICAL SPECIFICATIONS	18
11. SCHEMATIC DIAGRAM	20

MODEL ST-310 STEREOPHONIC TUNER

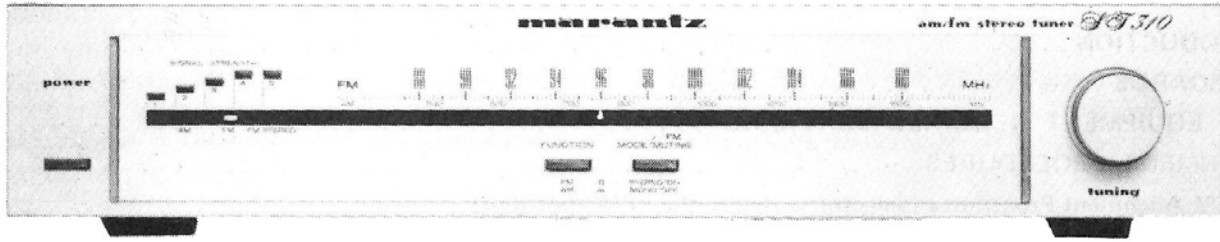

1. INTRODUCTION

This service manual was prepared for use by Authorized Warranty Stations and contains service information for Marantz Model ST310 AM/FM Stereophonic Tuner. Servicing information and voltage data included in this manual are intended for use by the knowledgeable and experienced technician only. All instructions should be read carefully. No attempt should be made to proceed without a good understanding of the operations in the Tuner.

The parts list furnishes information by which replacement parts may be ordered from the Marantz Company. A simple description is included for parts which can usually be obtained through local suppliers.

2. P.W. BOARDS

As can be seen from the circuit diagram, the chassis of Model ST310 consists of the following units. Each unit mounted on a printed circuit board is described within the square enclosed by a bold dotted line on the circuit diagram.

1. Tuner mounted on P.W. Board P100
2. Signal Strength and Function LED mounted on P.W. Board PX00
3. Pointer LED mounted on P.W. Board P001

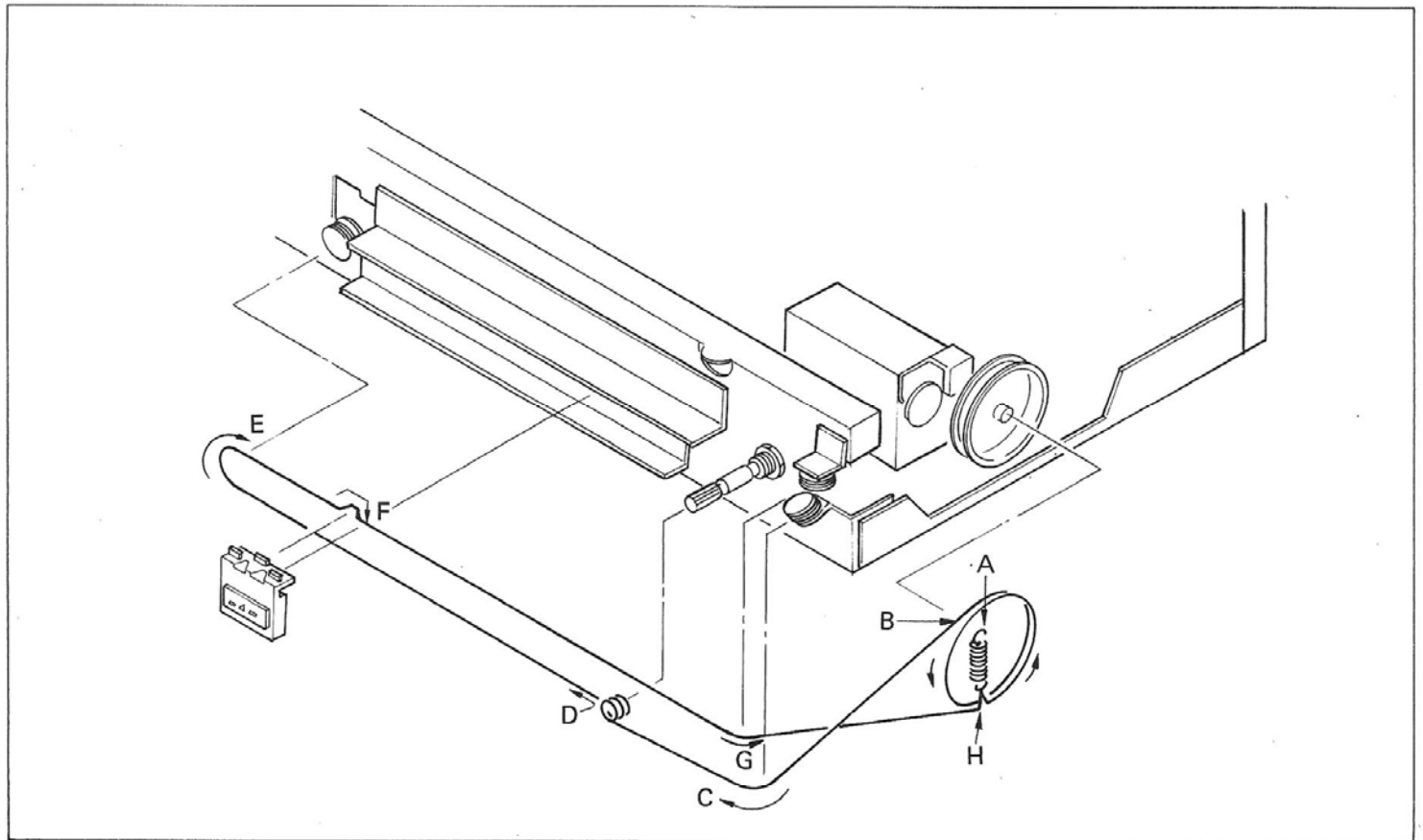

Figure 1. Dial Stringing

3. TEST EQUIPMENT REQUIRED FOR SERVICING

This table lists the test equipment required for servicing the Model ST310 Tuner.

Item	Manufacturer and Model No.	Use
AM Signal Generator		Signal source for AM alignment
Test Loop		Use with AM Signal Generator
FM Signal Generator MPX Signal Generator	Sound Technology Model 1000A	Signal source for FM alignment Stereo separation alignment and trouble shooting
Distortion Analyzer Audio Oscillator AC VTVM	Sound Technology Model 1700A	Distortion measurements Sinewave and squarewave signal source Voltage measurements (AC)
Oscilloscope	Tektronix Model T932 Philips Model 3232	Waveform analysis and trouble shooting
Frequency Counter	Fluke Model 1900A	MPX Oscillator adjustment (VCO)
Circuit Tester		Trouble shooting
DC VTVM	Fluke Model 8000 "Digital" Simpson Model 313, Triplet Model 801	Voltage measurements (DC)
AC Wattmeter	Simpson Model 1379	Monitors primary power to tuner
Line Voltmeter	Simpson Model 1359	Monitors potential of primary power to tuner
Variable Autotransformer	Superior Electronic Co., Powerstat Model 116B-10A	Adjusts level of primary power to tuner

4. ALIGNMENT PROCEDURES

A dummy resistor of 47 kohms must be connected across the tuner output terminals before alignment.

4.1 FM Alignment Procedures (Selector switch in the "FM" position)

1. FM IF Alignment

Step	Signal Source Connection	Signal Frequency	Indicator Connection	Set Dial Pointer to:	Adjust:
1	Sweep generator to point (B) through 5pF capacitor	10.7 MHz marker at 10.6, 10.7 and 10.8 MHz	Oscilloscope to point (C)	Quiet point on band.	L107 for maximum and symmetric response.
2			Oscilloscope to point (D) (J104)		L108 (orange) for straight and symmetric "S" curve response.
3	Repeat steps 1 and 2.				

2. FM RF Alignment

Step	Signal Source Connection	Signal Frequency	Indicator Connection	Set Dial Pointer to:	Adjust:
1	RF generator to FM antenna terminals (A) through matching network (300 ohms, balanced) (Maintain RF level below limit.)	87.4 MHz	VTVM to L or R channel output (W002)	87.4 MHz with tuning gang closed.	L105 for maximum output.
2		108.2 MHz		108.2 MHz with tuning gang open.	C115 for maximum output.
3		90 MHz		90 MHz	L102, L104 for maximum output.
4		106 MHz		106 MHz	ANT. RF. TRIM. CAP. for maximum output.
5	Repeat steps 1 to 4.				
6	Check overall response curve and repeat above steps as necessary to obtain maximum sensitivity.				
7	No connection	No signal	Center Meter between J104-J105		L108 Right core (orange) center tuning meter pointer indicates its center.
8	RF generator 1 m V output to FM antenna terminals (A) through matching network (300 ohms, balanced)	98 MHz	Distortion meter to output (W002)	98 MHz	L108 Left core (black) for minimum distortion.
9					
10		98 MHz		98 MHz	R137 So that signal Strength LED may light 5 point.

4.2 Muting Circuit Alignment

Step	Signal Source Connection	Signal Frequency	Indicator Connection	Set Dial Pointer to:	Adjust:
1	RF generator 12.5 μ V output to FM antenna terminals (A) through matching network (300 ohms, balanced)	98 MHz	VTVM to R or L channel output (W 002)	98 MHz	If the muting level is over 25 μ V, cut R124. (During this adjustment turn the muting push-switch "ON".)

4.3 Multiplex Alignment Procedures (Selector switch in the "FM" position)

Step	Signal Source Connection	Signal Frequency	Indicator Connection	Set Dial Pointer to:	Adjust:	
1	RF generator to FM antenna terminals (A) through matching network (300 ohms, balanced), with 1mV FM stereo simulator RF level and 100% modulation (pilot 9%)	No Modulation	Frequency counter to point (E) (J305)	98 MHz	R305 so that Frequency counter may precisely read 76 kHz	
2		Stereo, left (1,000 Hz)	VTVM to right channel output (W002, red)		R325 for same separation in both channels.	
3		Stereo, right (1,000 Hz)	VTVM to left channel output (W 002, white)			
4		Repeat steps 2 and 3.				
5		Pilot only		VTVM to R or L channel output (W002)	98MHz	R310 so that minimum output should be the same in both channels.

4.4 AM Alignment Procedures (Selector switch in the "AM" position)

1. AM IF Alignment

Step	Signal Source Connection	Signal Frequency	Indicator Connection	Set Dial Pointer to:	Adjust:
1	Sweep generator to point (F)	450 kHz marker	Oscilloscope to point (G)	Quiet point on band	LA02, LA03 for maximum and symmetric response.

2. AM RF Alignment

Step	Signal Source Connection	Signal Frequency	Indicator Connection	Set Dial Pointer to:	Adjust:
1	Apply the signal to the AM bar antenna from the RF generator using the test loop.	525 kHz	VTVM to L or R channel output (W002)	525 kHz with tuning gang closed.	LA01 for maximum output.
2		1,630 kHz		1,630 kHz with tuning gang open	OSC. TRIM. CAP. for maximum output.
3		600 kHz		600 kHz	L051 for maximum output.
4		1,400 kHz		1,400 kHz	ANT. TRIM. CAP. for maximum output.
5		Repeat steps 1 to 4 as necessary to obtain maximum sensitivity.			

ALIGNMENT POINT

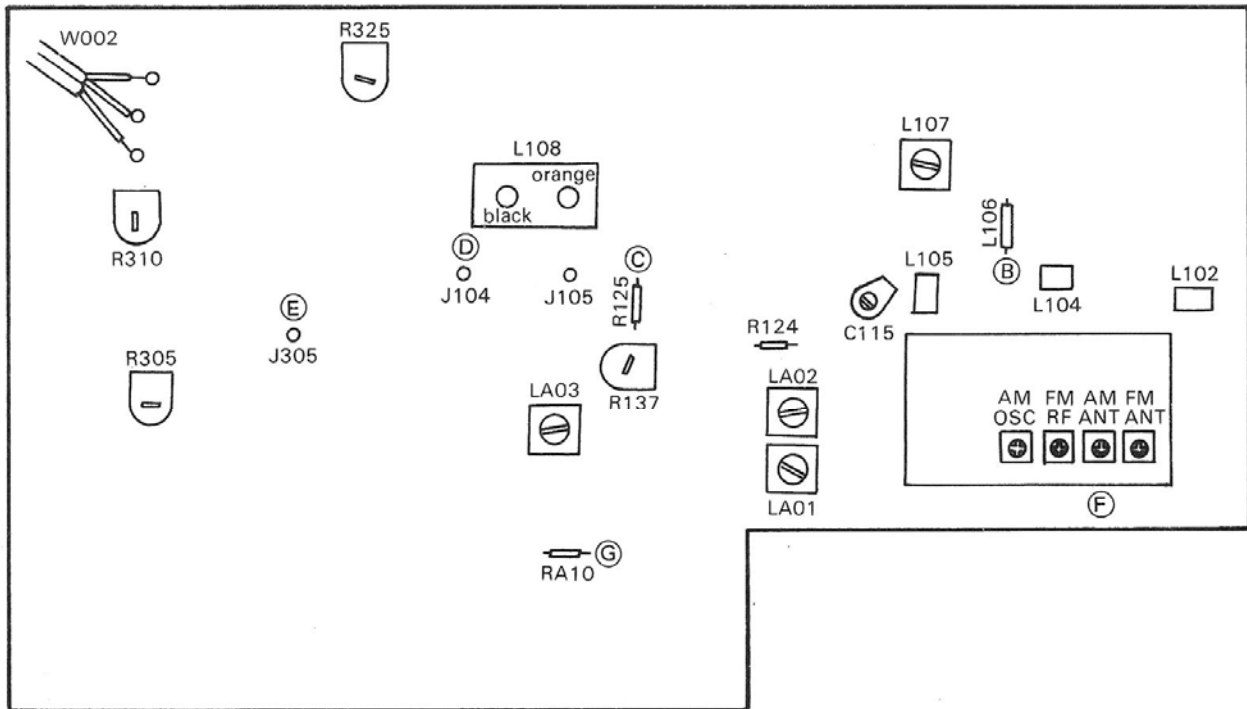

5. VOLTAGE CONVERSION

● EUROPEAN MODEL ONLY

To convert the unit to a different power source voltage, change the position as illustrated in the drawing below.

CAUTION

DISCONNECT POWER SUPPLY CORD FROM AC OUT.
LET BEFORE CONVERTING VOLTAGE.

Voltage Conversion Chart

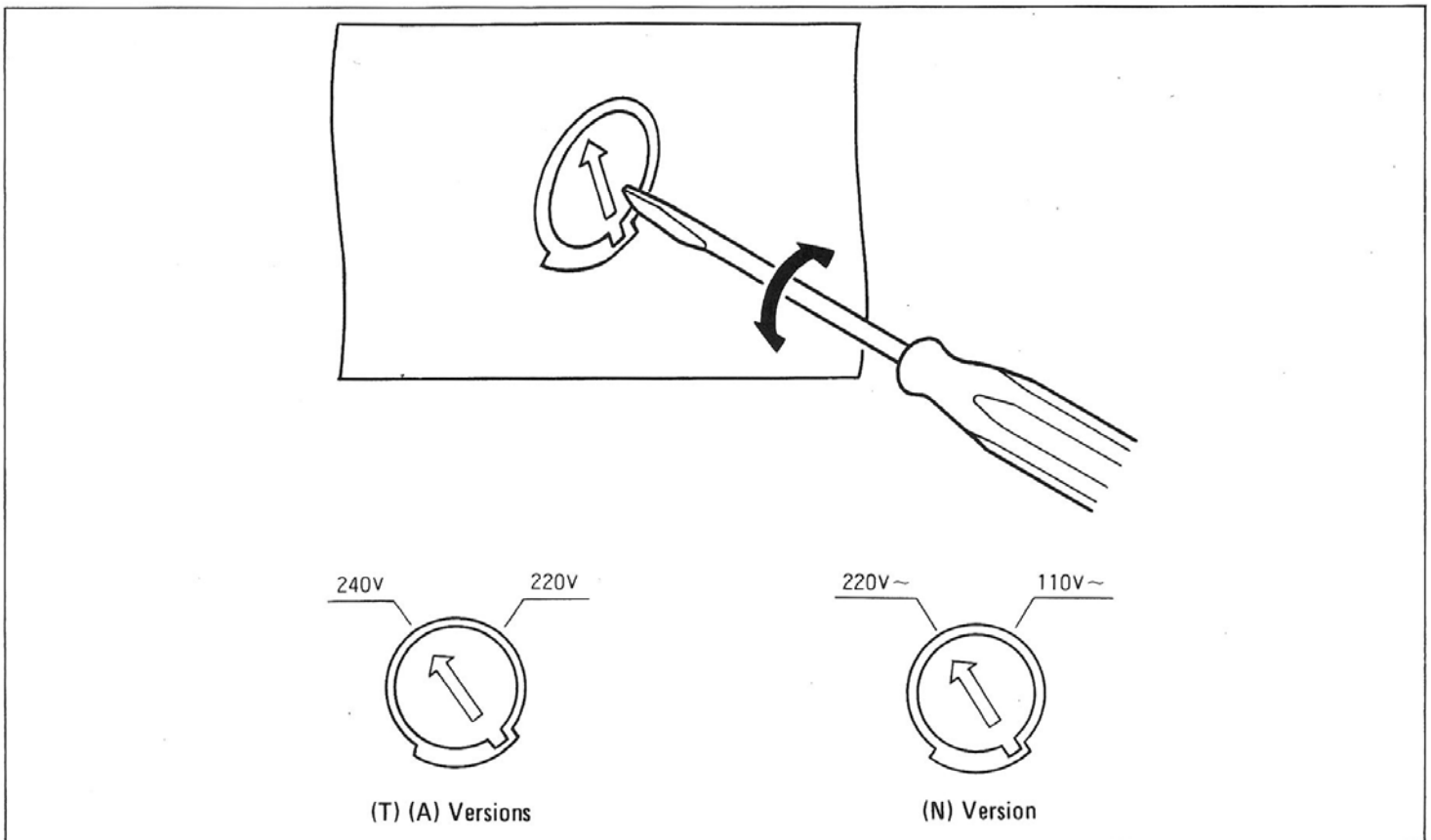

NOTE ON SAFETY:

THE PARTS MARKED WITH \triangle ARE IMPORTANT PARTS ON THE SAFETY. PLEASE USE THE PARTS HAVING THE DESIGNATED PARTS NUMBERS WITHOUT FAIL.

FTZ REGULATION

Instruction for the use in the range other than specified in FTZ codes.

Achtung für die Leute, die in dem Gebiet wohnen, wo die FTZ-Bestimmungen vorherrschend sind.

Sollte das Gerät auch für Frequenzen ausserhalb des in den FTZ-Bestimmungen angegebenen Bereiches empfangsbereit sein, bitten wir, den Bereich durch Nachstellen des Kernes in der Oszillatortspule (in der Abbildung mit "FTZ" gekennzeichnet) so zu korrigieren, dass er den Bestimmungen entspricht.

6. BLOCK DIAGRAM

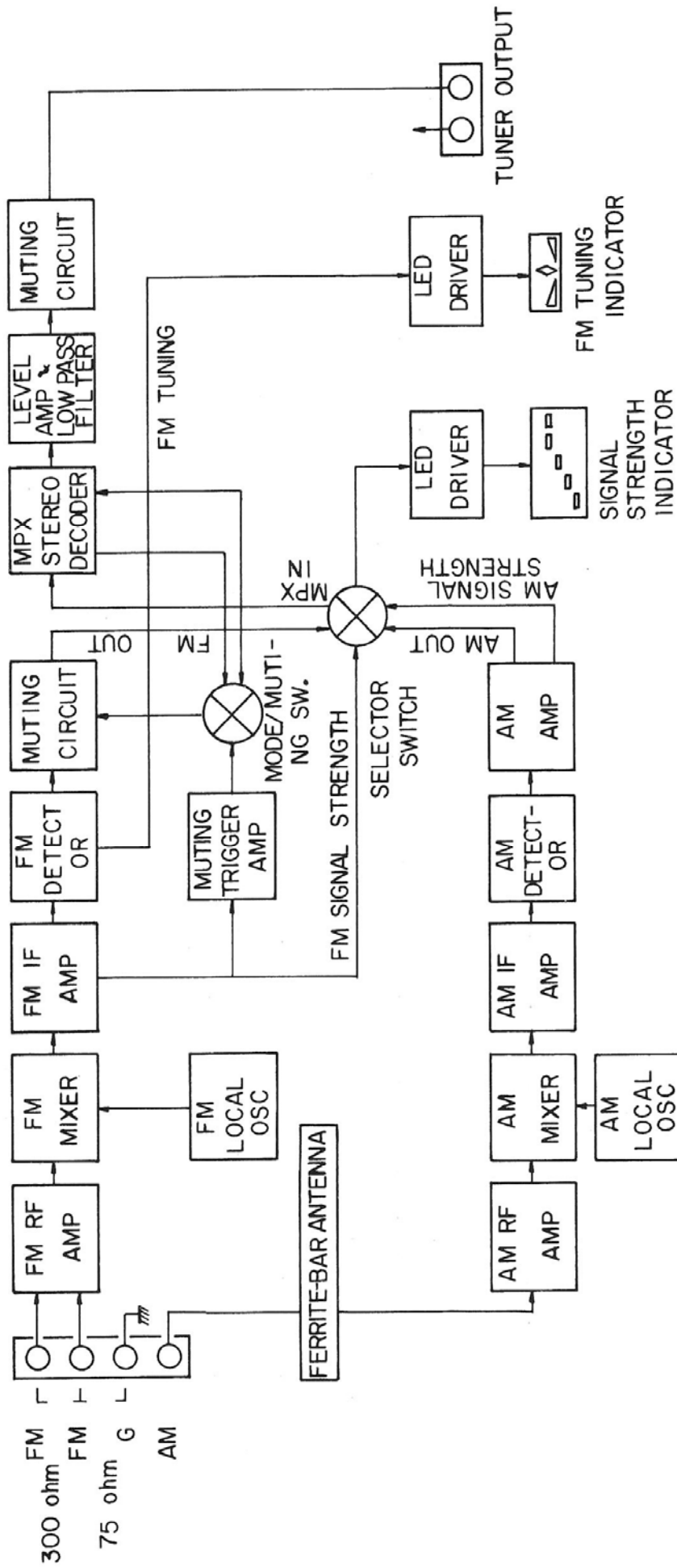

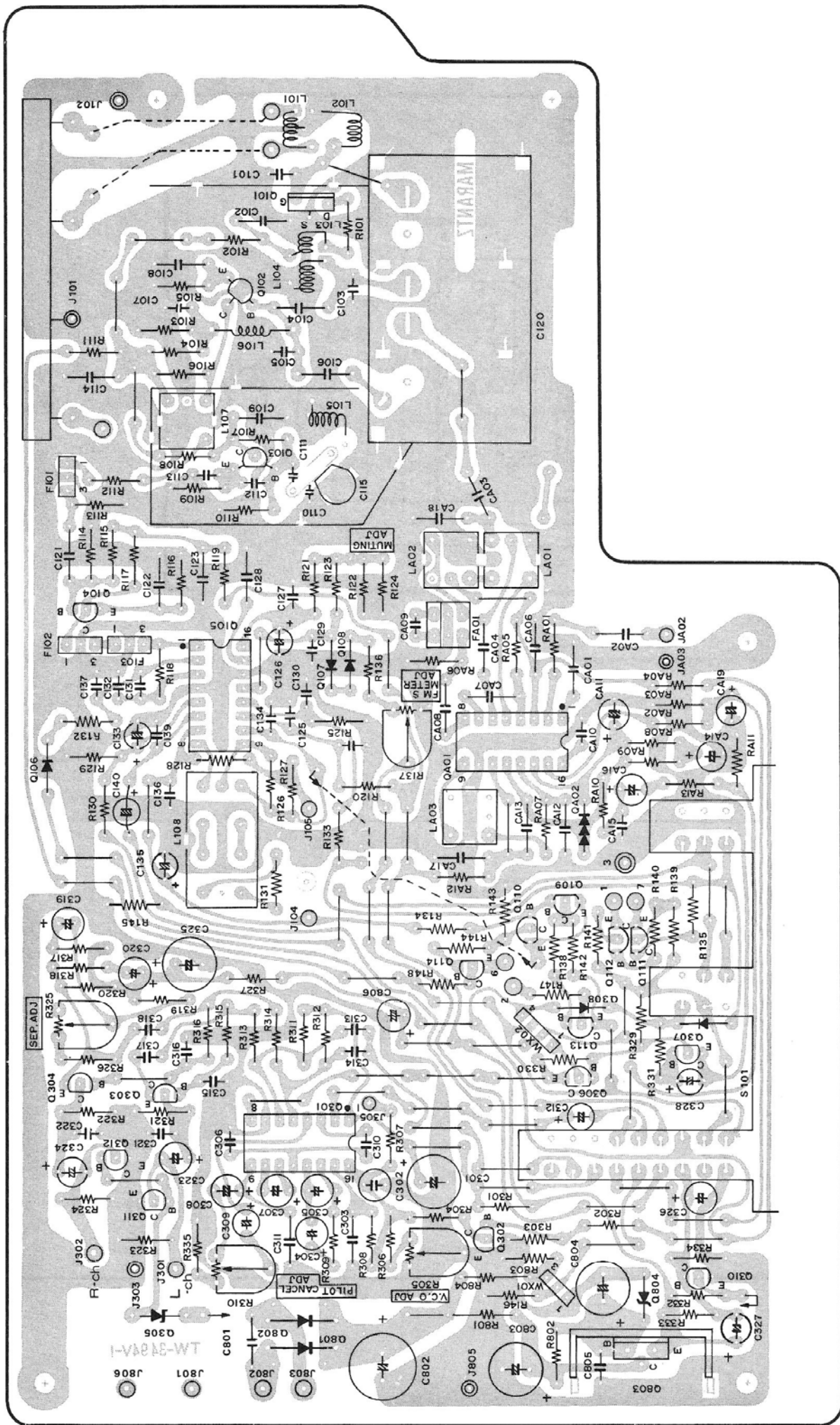

7.2 Func./Signal Strength LED Assembly (PX00) Schematic Diagram and Component Locations

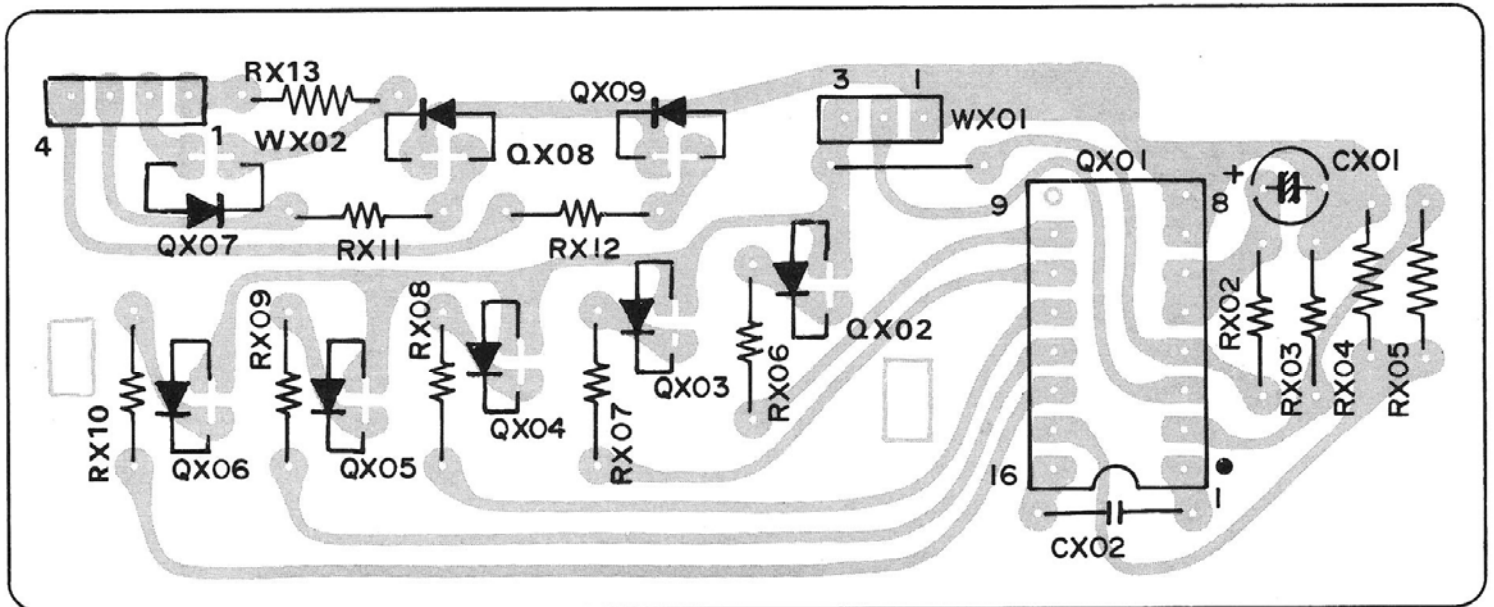
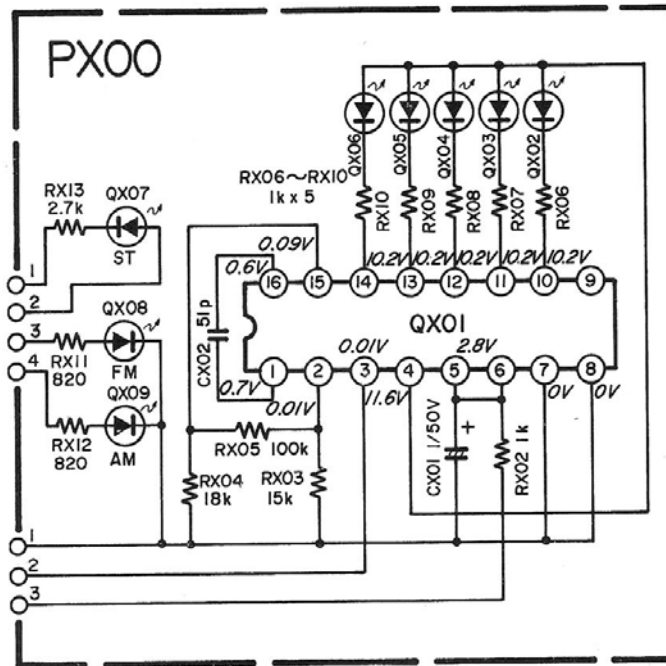

8. EXPLODED VIEW AND PARTS LIST

• [C01-99] Front Panel

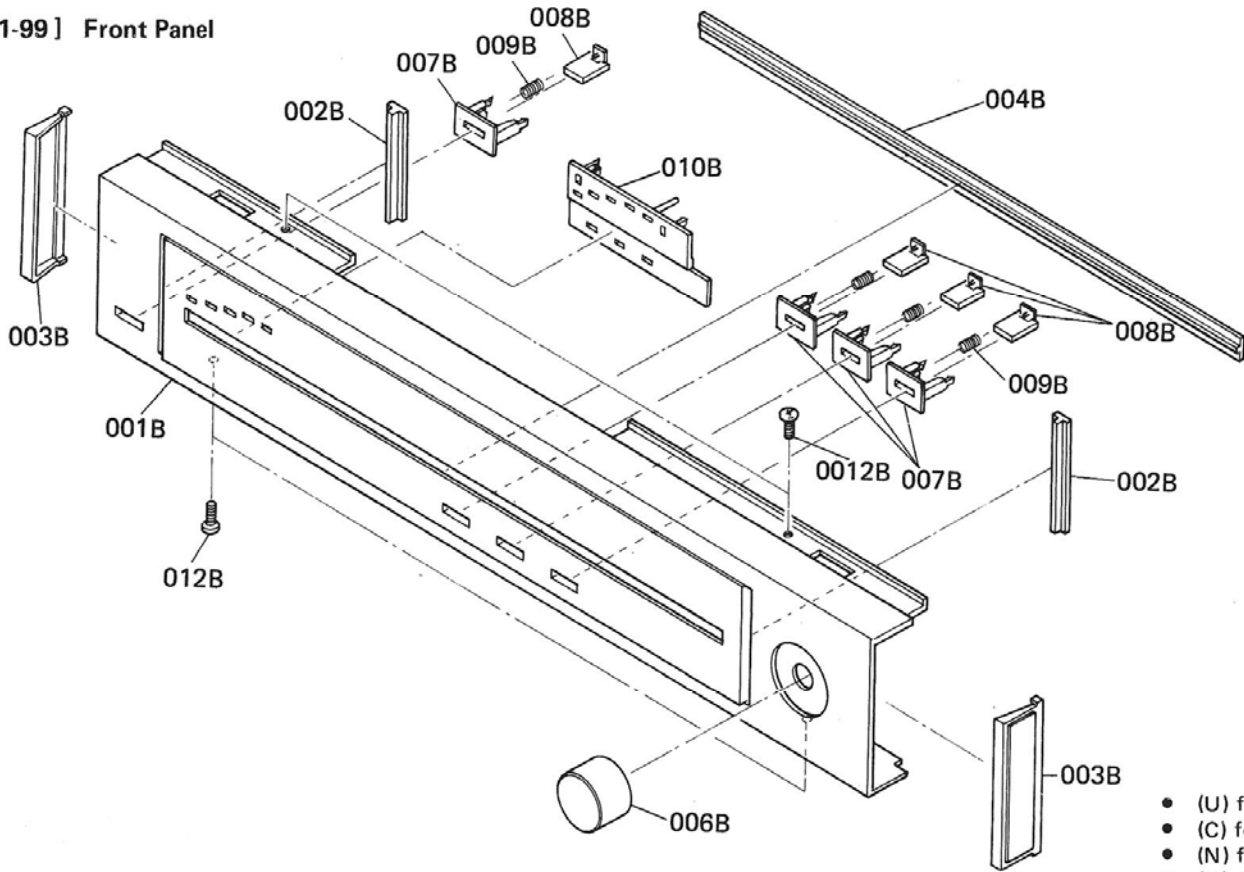

- (U) for U.S.A.
- (C) for Canada
- (N) for Europe
- (A) for Australia

REF. DESIG.	Q'TY				PART NO.	DESCRIPTION	REF. DESIG.	Q'TY				PART NO.	DESCRIPTION
	U	C	N	A				U	C	N	A		
A	1	1			403H063400	Front Panel Assembly	006B	1	1	1	1	403H154020	Knob, Tuning
A2			1	1	403H063410	Front Panel Assembly	012B	4	4	4	4	51280308B0	B.H. Tapped Screw B3 x 8
001B	1	1			403H063010	Escutcheon							
001B			1	1	403H063030	Escutcheon, Front Panel							
002B	2	2	2	2	403H063020	Escutcheon, Side Panel							
003B	2	2	2	2	403H067010	Cap							
004B	1	1	1	1	403H158010	Window							
007B	4	4	3	3	403H259010	Bushing							
008B	4	4	3	3	403H154010	Knob, Push SW.							
009B	4	4	3	3	403H115010	Spring, Push SW.							
010B	1	1	1	1	403H053020	Cover, Led							

● [C02-99] Top and Bottom cover

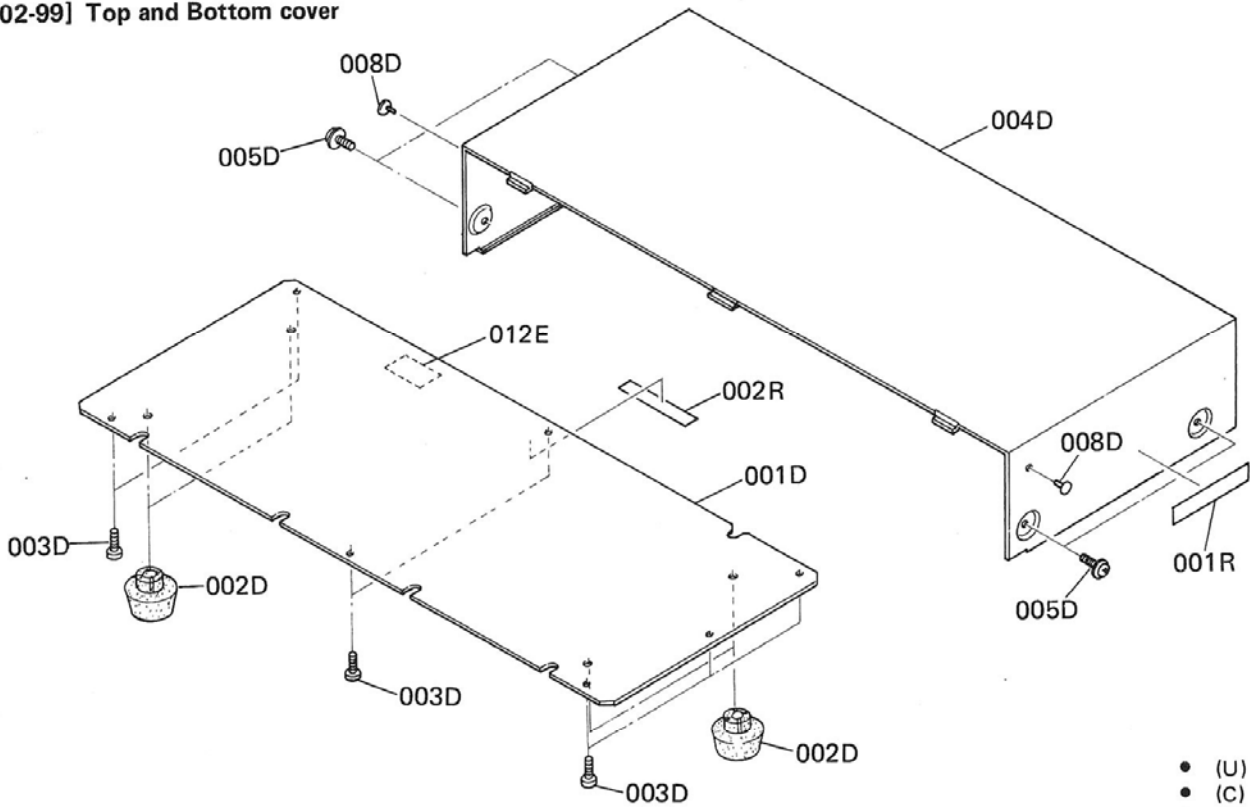

- (U) for U.S.A.
- (C) for Canada
- (N) for Europe
- (A) for Australia

REF. DESIG.	Q'TY				PART NO.	DESCRIPTION	REF. DESIG.	Q'TY				PART NO.	DESCRIPTION
	U	C	N	A				U	C	N	A		
001D	1	1	1	1	403H257020	Lid, Bottom cover	004D	1	1	1	1	403H257010	Lid, Top Cover
002D	4	4	4	4	403H057010	Leg	005D	4	4	4	4	51260408U0	B.T.Screw (w/w) B4 x 8
003D	7	7	7	7	51280308B0	B.H.Tapped Screw B3 x 8	008D	2	2	2	2	2991259010	Bushing, Top Cover Side
012E				1	2978120070	Insulator							
001R		1			2911861110	Label							
001R	1		1		2932861010	Label							
002R		1			2911861140	Label							
002R	1		1	1	2578861010	Label							

● [C03-99] Rear Panel

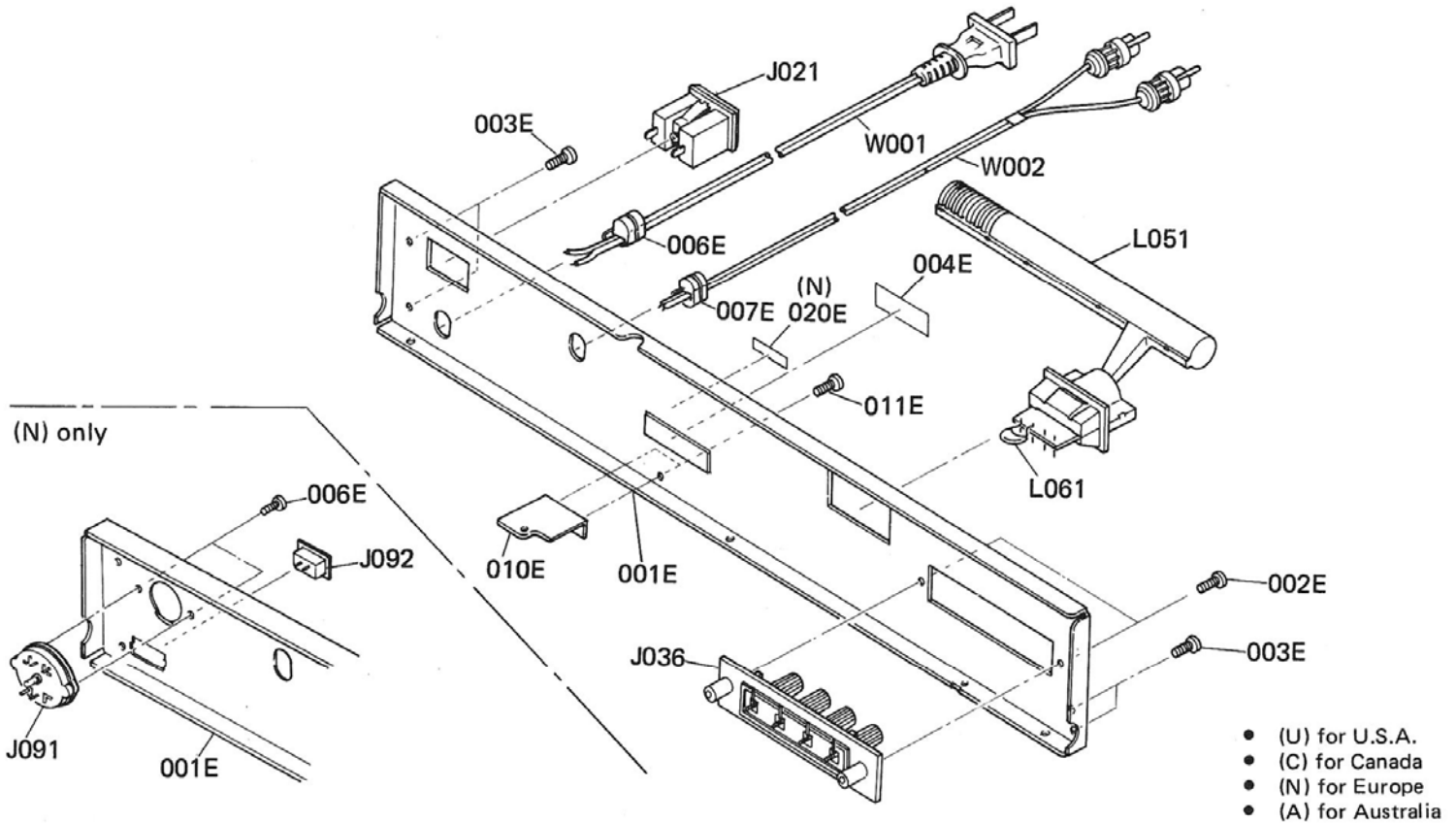

REF. DESIG.	Q'TY				PART NO.	DESCRIPTION
	U	C	N	A		
001E	1				403H160210	Bracket, Rear Panel
001E			1		403H160220	Bracket, Rear Panel
001E				1	403H160230	Bracket, Rear Panel
001E		1			403H160250	Bracket, Rear Panel
002E	2	2	2	2	51280308U0	B.H.Tapped Screw B3 x 8
003E	4	4	4	4	51280308U0	B.H.Tapped Screw B3 x 8
004E	1	1	1	1	2112265010	Indicator, Serial NO. Label
006E	1	1			1455259030	Bushing, AC Cord
006E			2	2	51280310U0	B.H. Tapped Screw B3 x 10
007E	1	1	1	1	1455259090	Bushing, Output Wire
010E	1	1	1	1	403H160030	Bracket, P.W.B.
011E	1	1	1	1	51280308U0	B.H.Tapped Screw B3 x 8
020E			1		458186010	Label

REF. DESIG.	Q'TY				PART NO.	DESCRIPTION
	U	C	N	A		
△ J021	1	1			YJ04000560	Jack, AC Outlet
J036	1	1	1	1	YJ01040210	Antenna Terminal, 4P
J091				1	BY05030040	Voltage Selector, 220/240V
J091				1	BY05060040	Voltage Selector, 110/220V
J092			1	1	YP04000580	Plug, AC Inlet
L051	1	1	1	1	LF11200620	Ant.Coil, AM Bar Ant.
L061	1	1	1	1	LC11540040	Choke coil 150μH
L062	1	1	1	1	LC13320050	Chock Coil 3.3μH
△ W001	1	1			YC01900070	A.C.Power Cord
△ W001				1	ZC01805010	A.C.Power Cord
△ W001				1	ZC02006020	A.C.Power Cord
W002			1	1	YB01000300	Connective Cord
W002	1	1			YB01000310	Connective Cord

● [P01-99] Front Chassis and General Parts

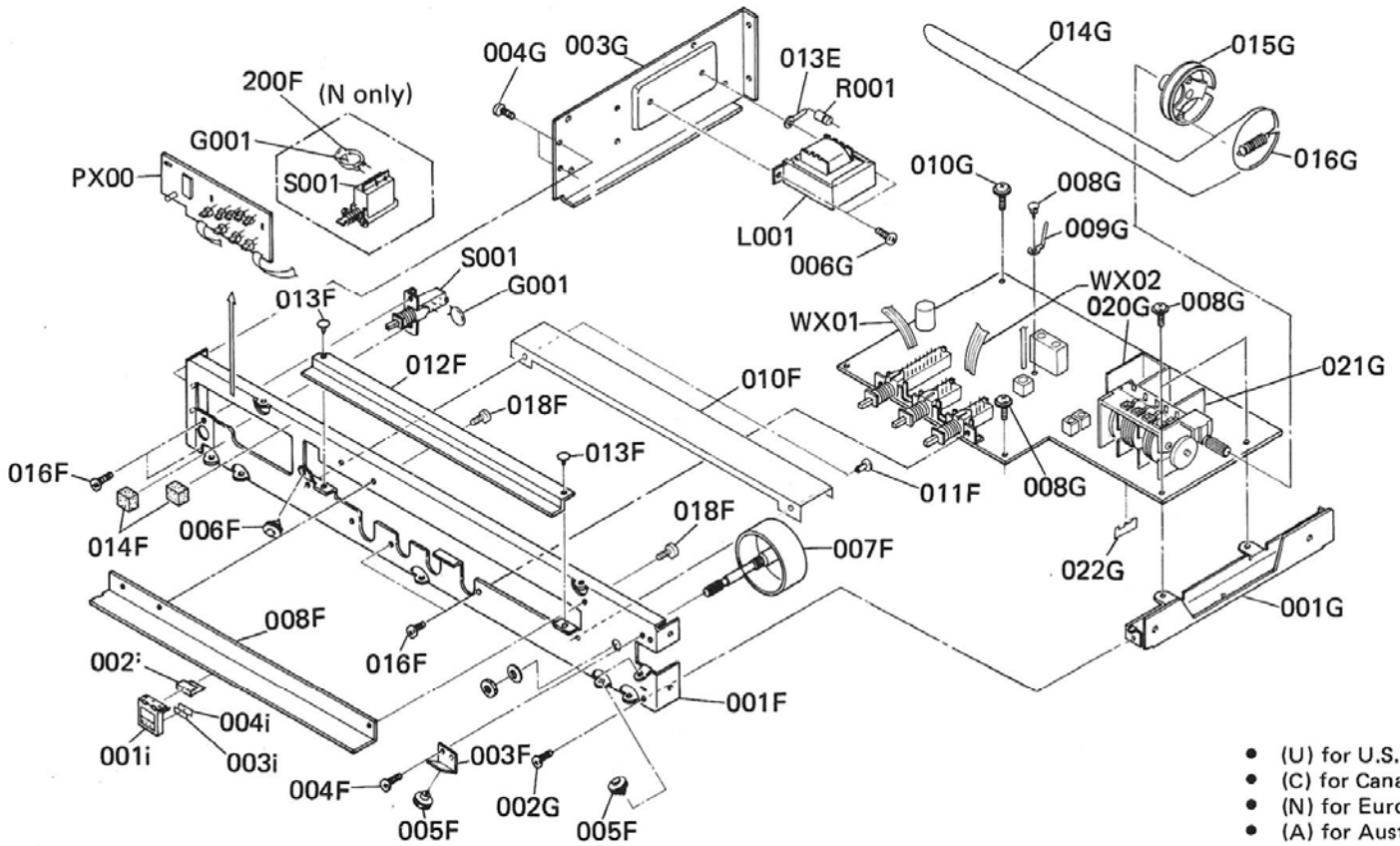

- (U) for U.S.A.
- (C) for Canada
- (N) for Europe
- (A) for Australia

REF. DESIG.	Q'TY				PART NO.	DESCRIPTION
	U	C	N	A		
013E	1	1			62040029W0	Lug
001F	1	1	1	1	403H160010	Bracket, Front Chassis
003F	1	1	1	1	403H160020	Bracket, Pulley
004F	1	1	1	1	51280308B0	B.H.Tapped Screw B3 x 8
005F	2	2	2	2	2276262500	Pulley
006F	1	1	1	1	2259262500	Pulley
007F	1	1	1	1	403H273010	Flywheel Assembly
008F	1	1	1	1	403H051010	Guide
010F	1	1	1	1	403H120020	Insulator
011F	2	2	2	2	2912259020	Bushing
012F	1	1	1	1	403H053010	Cover
013F	2	2	2	2	2912259020	Bushing
014F	2	2	2	2	2147056010	Buffer
016F	4	4	4	4	51100306A9	B.H.M.Screw B3 x 6
018F	2	2	2	2	51280308B0	B.H.Tapped Screw B3 x 8

REF. DESIG.	Q'TY				PART NO.	DESCRIPTION
	U	C	N	A		
001G	1	1	1	1	403H126010	Stay
002G	1	1	1	1	51280308B0	B.H.Tapped Screw B3 x 8
003G	1	1	1	1	403H126020	Stay
004G	2	2	2	2	51280308B0	B.H.Tapped Screw B3 x 8
006G	2	2	2	2	51280406B0	B.H.Tapped Screw B4 x 6
008G	4	4	4	4	51260308B0	B.T.Screw B3 x 8
009G	1	1	1	1	2871005010	Clamper
010G	1	1	1	1	2912259020	Bushing
014G	120	120	120	120	72040805A0	String
015G	1	1	1	1	403H159010	Drum
016G	1	1	1	1	2112115020	Spring
020G	1	1	1	1	2259109040	Shield
021G	1	1	1	1	2259109050	Shield
022G	1	1	1	1	2259109060	Shield
△ L001				1	TS14128220	Power Transformer (110/220V)
△ L001	1	1			TS14128210	Power Transformer (120V)
△ R001	1	1			RC10225120	Resistor 2.2MΩ 1/2W
R002				1	GJ05102020	Resistor 1kΩ 2W
△ S001				1	SP01010390	Push Switch, Power
△ S001	1	1			SP01010330	Push Switch, Power
△ G001				1	DK18103840	Ceramic Capacitor Spark Killer
△ G001	1	1			DK18103530	Ceramic Capacitor 0.01μF
001i	1	1	1	1	403H103010	Pointer
002i	1	1	1	1	403H118010	Spacer
003i	1	1	1	1	403H303020	Mask
004i	1	1	1	1	403H303030	Mask

• [H01-99] Packing Materials

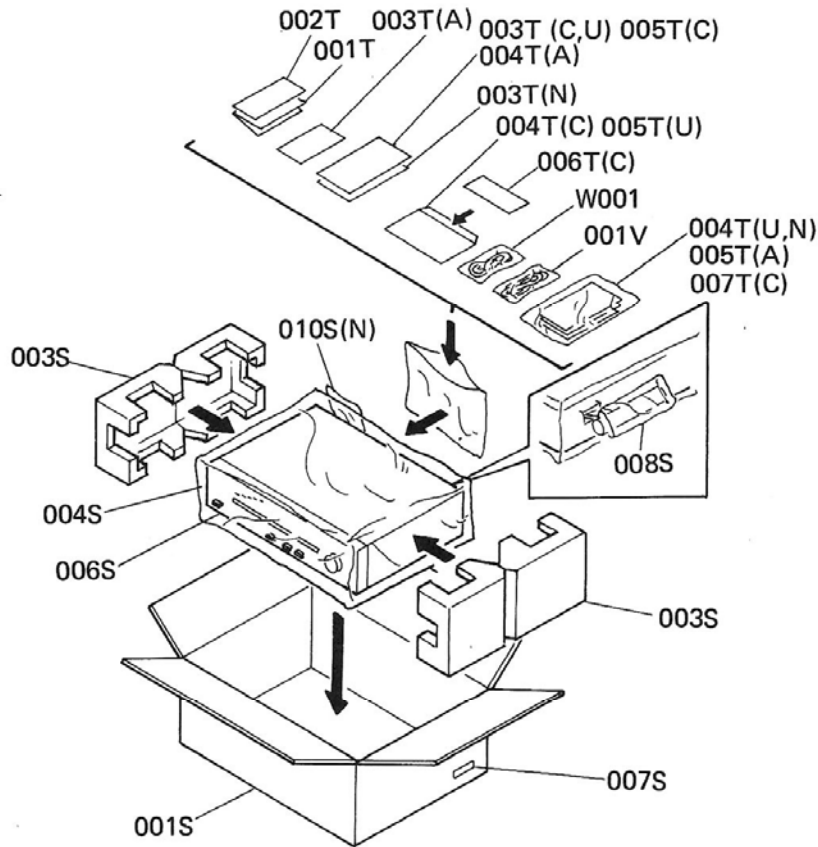

- (U) for U.S.A.
- (C) for Canada
- (N) for Europe
- (A) for Australia

REF. DESIG.	Q'TY				PART NO.	DESCRIPTION
	U	C	N	A		
001S			1	1	403H801020	Packing Case
001S	1	1			403H801010	Packing Case
003S	2	2	2	2	001H809010	Cushion, Side
004S	1	1	1	1	9090909040	Polyethylene Sheet
006S	1	1	1	1	2918107360	Sheet
007S				2	9526019030	Serial No. Card
007S		2			9526019020	Serial No. Card
007S			2		9526019060	Serial No. Card
007S	2				9526019010	Serial No. Card
008S	1	1	1	1	2819056020	Buffer, AM Bar Ant.
010S				1	2731821010	Silicagel
015S		2			9510901020	Label

REF. DESIG.	Q'TY				PART NO.	DESCRIPTION
	U	C	N	A		
001T	1			1	403H851010	Instructions
001T		1	1		403H851310	Instructions
002T	1			1	403H851020	Instructions
002T		1			403H851220	Instructions
002T			1		403H851320	Instructions
003T				1	2205851040	Instructions
003T		1			2818854040	Guarantee Card
003T			1		403H856010	Circuit Diagram
003T	1				2818854020	Guarantee Card
004T				1	9631000090	Guarantee Card
004T		1			2918813010	Envelope
004T	1		1		9013025010	Polyethylene Bag
005T	1				2225813010	Envelope
005T				1	9013025010	Polyethylene Bag
005T		1			9630000180	Guarantee Card
006T		1			9650000050	S. Station Card
007T		1			9013025010	Polyethylene Bag
001V	1	1	1	1	ZA02000070	Ext. Antenna
W001			1		ZC01805010	A.C.Power Cord
W001				1	ZC02006020	A.C.Power Cord

9. ELECTRICAL PARTS LIST

• (U) for U.S.A. • (N) for Europe
• (C) for Canada • (A) for Australia

REF. DESIG.	Q'TY				PART NO.	DESCRIPTION
	U	C	N	A		
P001	1	1	1	1	YF403H0010	P001-LED BOARD P.W.Board LED
Q001	1	1	1	1	HI10014300	P001-SEMICONDUCTOR LED
P100	1	1	1	1	WK403H1210	P100-TUNER CIRCUIT BOARD P.W.Board, Tuner & Main
	1	1			ZZ403H1210	P.W.Board Assembly
			1	1	ZZ403H8210	P.W.Board Assembly
						P100-CAPACITORS
C101	1	1	1	1	DD11100370	Ceramic 10pF ±0.5pF
C102	1	1	1	1	DA17103010	Ceramic 0.01µF ±20%
C103	1	1	1	1	DD11100370	Ceramic 10pF ±0.5pF
C104	1	1	1	1	DA16056010	Ceramic 5.6pF ±10%
C105	1	1	1	1	DD11100370	Ceramic 10pF ±0.5pF
C106	1	1	1	1	DA17010010	Ceramic 1pF ±20%
C107	1	1	1	1	DD15301360	Ceramic 300pF ±5%
C108	1	1	1	1	DA17103010	Ceramic 0.01µF ±20%
C109	1	1	1	1	DA17103010	Ceramic 0.01µF ±20%
C110	1	1	1	1	DD15150330	Ceramic 15pF ±5%
C111	1	1	1	1	DD11100300	Ceramic 10pF ±0.5pF
C112	1	1	1	1	DD15150300	Ceramic 15pF ±5%
C113	1	1	1	1	DD15150300	Ceramic 15pF ±5%
C114	1	1	1	1	DA17103010	Ceramic 0.01µF ±20%
C115	1	1	1	1	CT11000010	Trimming 10pF
C120	1	1	1	1	CA32400110	Variable Matsushita ECV-5MD34
C121	1	1	1	1	DA17103010	Ceramic 0.1µF ±20%
C122	1	1	1	1	DA17103010	Ceramic 0.01µF ±20%
C123	1	1	1	1	DA17103010	Ceramic 0.01µF ±20%
C125	1	1	1	1	DK18473320	Ceramic 0.047µF+100%—0%
C126	1	1	1	1	EA10505030	Elect 1µF 50V
C127	1	1	1	1	DK18223320	Ceramic 0.022µF+80%—20%
C128	1	1	1	1	DA17103010	Ceramic 0.01µF +20%
C129	1	1	1	1	DK18223320	Ceramic 0.022µF+80%—20%
C130	1	1	1	1	DK18473320	Ceramic 0.047µF+60%—40%
C131	1	1	1	1	DK18473320	Ceramic 0.047µF+60%—40%
C132	1	1	1	1	DK18473320	Ceramic 0.047µF+60%—40%
C133	1	1	1	1	EA33505090	Elect 3.3µF 50V
C134	1	1	1	1	DK18473320	Ceramic 0.047µF+60%—40%
C135	1	1	1	1	EA47405030	Elect 0.47µF 50V
C136	1	1	1	1	DK18473320	Ceramic 0.047µF
C137	1	1	1	1	DK18473320	Ceramic 0.047µF
C139	1	1	1	1	DD15151370	Ceramic 150pF ±5%
C140	1	1	1	1	EA22505030	Elect 2.2µF 50V
C301	1	1	1	1	EA22701630	Elect 220µF 16V
C302	1	1	1	1	DF55102090	Film 1000pF ±5%
C303	1	1	1	1	DA17222010	Ceramic 2200pF ±20%
C304	1	1	1	1	EA33505090	Elect 3.3µF 50V
C305	1	1	1	1	EA47405030	Elect 0.47µF 50V
C306	1	1	1	1	DF16152300	Film 1500pF ±10%
C307	1	1	1	1	EA33505090	Elect 3.3µF 50V
C308	1	1	1	1	EA33405030	Elect 0.33µF 50V
C309	1	1	1	1	EA33405030	Elect 0.33µF 50V
C310	1	1	1	1	DF17473300	Film 0.047µF±20%
C311	1	1	1	1	DA17103010	Ceramic 0.01µF ±20%
C312	1	1	1	1	EA47503530	Elect 4.7µF 35V
C313	1	1			DF15183300	Film 0.018µF±5%
C313			1	1	DF15123300	Film 0.012µF±5%
C314	1	1			DF15183300	Film 0.018µF±5%

REF. DESIG.	Q'TY				PART NO.	DESCRIPTION
	U	C	N	A		
C314			1	1	DF15123300	Film 0.012µF±5%
C315	1	1	1	1	DD15181370	Ceramic 180pF ±5%
C316	1	1	1	1	DD15181370	Ceramic 180pF ±5%
C317	1	1	1	1	DF15332300	Film 3300pF ±5%
C318	1	1	1	1	DF15332300	Film 3300pF ±5%
C321	1	1	1	1	DF15562300	Film 5600pF ±5%
C322	1	1	1	1	DF15562300	Film 5600pF ±5%
C323	1	1	1	1	EA33405030	Elect 0.33µF 50V
C324	1	1	1	1	EA33405030	Elect 0.33µF 50V
C325	1	1	1	1	EA47701630	Elect 470µF 16V
C326	1	1	1	1	EA47601630	Elect 47µF 16V
C327	1	1	1	1	EA47503590	Elect 4.7µF 35V
C328	1	1	1	1	EA10505030	Elect 1µF 50V
C329	1	1	1	1	EA22505030	Elect 1µF 50V
△C801	1	1	1	1	DK18103510	Ceramic 0.01µF+80%—20%
△C802	1	1	1	1	EA47703530	Elect 470µF 35V
△C803	1	1	1	1	EA22702530	Elect 220µF 25V
△C804	1	1	1	1	EA47701630	Elect 470µF 16V
△C805	1	1	1	1	DK17103300	Ceramic 0.01µF ±20%
C806	1	1	1	1	EA10601690	Elect 10µF 16V
CA01	1	1	1	1	DA17102010	Ceramic 1000pF ±20%
CA02	1	1	1	1	DA17103010	Ceramic 0.01µF ±20%
CA03	1	1	1	1	DF55391090	Film 390pF ±5%
CA04	1	1	1	1	DA17103010	Ceramic 0.01µF ±20%
CA06	1	1	1	1	DA17103010	Ceramic 0.01µF ±20%
CA07	1	1	1	1	DA17103010	Ceramic 0.01µF ±20%
CA08	1	1	1	1	DA17103010	Ceramic 0.01µF ±20%
CA09	1	1	1	1	DD15470370	Ceramic 47pF ±5%
CA10	1	1	1	1	DK18473320	Ceramic 0.047µF+80%—20%
CA11	1	1	1	1	EA10601690	Elect 10µF 16V
CA12	1	1	1	1	DA17102010	Ceramic 1000pF ±20%
CA13	1	1	1	1	DA17103010	Ceramic 0.01µF ±20%
CA14	1	1	1	1	EA47503590	Elect 4.7µF 35V
CA15	1	1	1	1	DF16333300	Film 0.033µF±10%
CA16	1	1			EA10405030	Elect 0.1µF 50V
CA16			1	1	DF16333300	Film 0.033µF±10%
CA17	1	1	1	1	DA17103010	Ceramic 0.01µF ±20%
CA18	1	1	1	1	DA15220040	Ceramic 22pF ±5%
CA19	1	1	1	1	EA10505030	Elect 1µF 50V
						P100-RESISTORS (All Resistors are ±5% & 1/4W)
R101	1	1	1	1	GD05101140	100Ω
R102	1	1	1	1	GD05101140	100Ω
R103	1	1	1	1	GD05222140	2.2kΩ
R104	1	1	1	1	GD05223140	22kΩ
R105	1	1	1	1	GD05102140	1kΩ
R106	1				GD05273140	27kΩ
R107	1	1	1	1	GD05103140	10kΩ
R108	1	1	1	1	GD05101140	100Ω
R109	1	1	1	1	GD05392140	3.9kΩ
R110	1	1	1	1	GD05103140	10kΩ
R111	1	1	1	1	GD05101140	100Ω
R112	1	1	1	1	GD05101140	100Ω
R113	1	1	1	1	GD05331140	330Ω
R114	1	1	1	1	GD05272140	2.7kΩ
R115	1	1	1	1	GD05153140	15kΩ
R116	1	1	1	1	GD05561140	560Ω
R117	1	1	1	1	GD05331140	330Ω
R118	1	1	1	1	GD05331140	330Ω
R119	1	1	1	1	GD05101140	100Ω
R120	1	1	1	1	GD05101140	100Ω

- (U) for U.S.A.
- (N) for Europe
- (C) for Canada
- (A) for Australia

REF. DESIG.	Q'TY				PART NO.	DESCRIPTION
	U	C	N	A		
R121	1	1	1	1	GD05103140	10kΩ
R122	1	1	1	1	GD05153140	15kΩ
R123	1	1	1	1	GD05183140	18kΩ
R124	1	1	1	1	GD05473140	47kΩ
R125	1	1	1	1	GD05473140	47kΩ
R126	1	1	1	1	GD05183140	18kΩ
R127	1	1	1	1	GD05103140	10kΩ
R128	1	1	1	1	GD05821140	820Ω
R129	1	1	1	1	GD05563140	56kΩ
R130	1	1	1	1	GD05223140	22kΩ
R131	1	1	1	1	GD05302140	3kΩ
R132	1	1	1	1	GD05224140	240kΩ
R133	1	1	1	1	GD05222140	2.2kΩ
R134	1	1	1	1	GD05104140	100kΩ
R135	1	1	1	1	GD05473140	47kΩ
R136	1	1	1	1	GD05473140	47kΩ
R137	1	1	1	1	RA01030260	Trimming 10kΩ
R138	1	1	1	1	GD05473140	47kΩ
R139	1	1	1	1	GD05152140	1.5kΩ
R140	1	1	1	1	GD05224140	220kΩ
R141	1	1	1	1	GD05681140	680Ω
R142	1	1	1	1	GD05473140	47kΩ
R143	1	1	1	1	GD05473140	47kΩ
R144	1	1	1	1	GD05473140	47kΩ
R145	1	1	1	1	GD05104140	100kΩ
R146	1	1	1	1	GD05473140	47kΩ
R147	1	1	1	1	GD05182140	1.8kΩ
R148	1	1	1	1	GD05182140	1.8kΩ
R301	1	1	1	1	GD05470140	47Ω
R302	1	1	1	1	GD05224140	220kΩ
R303	1	1	1	1	GD05333140	33kΩ
R304	1	1	1	1	GD05272140	2.7kΩ
R305	1	1	1	1	RA03020030	Trimming 3kΩ
R306	1	1	1	1	GD05682140	6.8kΩ
R307	1	1	1	1	GD05224140	220kΩ
R308	1	1	1	1	GD05333140	33kΩ
R309	1	1	1	1	GD05102140	1kΩ
R310	1	1	1	1	RA05030090	Trimming 50kΩ
R311	1	1	1	1	GD05392140	3.9kΩ
R312	1	1	1	1	GD05392140	3.9kΩ
R313	1	1	1	1	GD05103140	10kΩ
R314	1	1	1	1	GD05103140	10kΩ
R315	1	1	1	1	GD05103140	10kΩ
R316	1	1	1	1	GD05103140	10kΩ
R319	1	1	1	1	GD05431140	430Ω
R320	1	1	1	1	GD05431140	430Ω
R321	1	1	1	1	GD05182140	1.8kΩ
R322	1	1	1	1	GD05182140	1.8kΩ
R323	1	1	1	1	GD05104140	100kΩ
R324	1	1	1	1	GD05104140	100kΩ
R325	1	1			RA02030060	Trimming 20kΩ
R325			1	1	RA01030260	Trimming 10kΩ
R326	1	1	1	1	GD05102140	1kΩ
R327	1	1	1	1	GD05471140	470Ω
R329	1	1	1	1	GD05682140	6.8kΩ
R330	1	1	1	1	GD05102140	1kΩ
R331	1	1	1	1	GD05104140	100kΩ
R332	1	1	1	1	GD05472140	4.7kΩ
R333	1	1	1	1	GD05124140	120kΩ
R334	1	1	1	1	GD05752140	7.5kΩ

REF. DESIG.	Q'TY				PART NO.	DESCRIPTION
	U	C	N	A		
R335	1	1	1	1	GD05823140	82kΩ
R801	1	1			GG05390120	39Ω ½W
△ R801			1	1	GJ05390020	39Ω ½W
△ R802	1	1	1	1	GD05152140	1.5kΩ
△ R803	1	1	1	1	GD05222140	2.2kΩ
△ R804	1	1	1	1	GG05751120	750Ω ½W
RA01	1	1	1	1	GD05221140	220Ω
RA02	1	1	1	1	GD05222140	2.2kΩ
RA03	1	1	1	1	GD05104140	100kΩ
RA04	1	1	1	1	GD05101140	100kΩ
RA05	1	1	1	1	GD05152140	1.5kΩ
RA06	1	1	1	1	GD05222140	2.2kΩ
RA07	1	1	1	1	GD05331140	330Ω
RA08	1	1	1	1	GD05103140	10kΩ
RA09	1	1	1	1	GD05103140	10kΩ
RA10	1	1	1	1	GD05152140	1.5kΩ
RA11	1	1	1	1	GD05333140	33kΩ
RA12	1	1	1	1	GD05101140	100Ω
RA13	1	1	1	1	GD05223140	22kΩ
Q101	1	1	1	1	HF200551D0	F.E.T. 2SK55D
Q102	1	1	1	1	HT310471C0	Transistor 2SC1047C
Q103	1	1	1	1	HT308291C0	Transistor 2SC829C
Q104	1	1	1	1	HT310471C0	Transistor 2SC1047C
Q105	1	1	1	1	HC10028030	IC LA1231N
Q106	1	1	1	1	HD20001210	Diode 1S2473C
Q107	1	1	1	1	HD20001210	Diode 1S2473C
Q108	1	1	1	1	HD20001210	Diode 1S2473C
Q109	1	1	1	1	HT309452B0	Transistor 2SC945 (P or C)
Q110	1	1	1	1	HT107332A0	Transistor 2SC733 (Q or R)
Q111	1	1	1	1	HT309452B0	Transistor 2SC945 (P or Q)
Q112	1	1	1	1	HT309452B0	Transistor 2SC945 (P or Q)
Q113	1	1	1	1	HT107332A0	Transistor 2SA733 (P or Q)
Q114	1	1	1	1	HT309452B0	Transistor 2SC945 (P or Q)
Q301	1	1	1	1	HC10029010	IC HA11223W
Q302	1	1	1	1	HT308281D0	Transistor 2SC828S
Q303	1	1	1	1	HT107502A0	Transistor 2SA750 (E or F)
Q304	1	1	1	1	HT107502A0	Transistor 2SA750 (E or F)
Q305	1	1	1	1	HD30002060	Zener RD (3 or 9)
Q306	1	1	1	1	HT309452B0	Transistor 2SC945 (P or Q)
Q307	1	1	1	1	HT309452B0	Transistor 2SC945 (P or Q)
Q308	1	1	1	1	HD20001210	Diode 1S2473C
Q309	1	1	1	1	HD20001210	Diode 1S2473C
Q310	1	1	1	1	HT326342B0	Transistor 2SC2634 (S or T)
Q311	1	1	1	1	HT326342B0	Transistor 2SC2634 (S or T)
Q312	1	1	1	1	HT326342B0	Transistor 2SC2634 (S or T)
△ Q801	1	1	1	1	HD20022100	Diode 10E1
△ Q802	1	1	1	1	HD20022100	Diode 10E1
△ Q803	1	1	1	1	HT403131D0	Transistor 2SD313D
△ Q804	1	1	1	1	HD30025090	Zener WZ-150
QA01	1	1	1	1	HC10041030	IC LA1240
QA02	1	1	1	1	HV00006120	Varistor MV-203

- (U) for U.S.A.
- (N) for Europe
- (C) for Canada
- (A) for Australia

REF. DESIG.	Q'TY				PART NO.	DESCRIPTION
	U	C	N	A		
F101	1	1	1	1	FF11070050	P100-FILTERS Ceramic FM CF SFE 10.7MD1
F102	1	1			FF11070050	Ceramic FM CF SFE 10.7MD1
F102			1	1	FF11070130	Ceramic FM CF SFE 10.7MS3G
F103	1	1			FF11070050	Ceramic FM CF SFE 10.7MD1
F103			1	1	FF11070130	Ceramic FM CF SFE 10.7MS3G
FA01	1	1	1	1	FF10045200	Ceramic Filter
L101	1	1	1	1	LL22803040	P100-COILS Ant. Coil FM
L102	1	1	1	1	LK11801030	Ant. Coil FM
L103	1	1	1	1	LL24800030	RF Coil FM
L104	1	1	1	1	LK11801030	RF Coil FM
L105	1	1	1	1	LK10801030	OSC Coil FM
L106	1	1	1	1	LC17510010	Choke Coil 0.75μH
L107	1	1	1	1	LI10016010	I.F.T. FM
L108	1	1	1	1	LI14030020	I.F.T. FM Det
LA01	1	1	1	1	LO10010480	OSC Coil AM
LA02	1	1	1	1	LI10015010	I.F.T. AM
LA03	1	1	1	1	LI10015060	I.F.T. AM
S101	1	1			SP06030180	P100-SWITCH Push Switch, Function/Mono /Muting
S101			1	1	SP06020130	Push Switch, Function/Mono /Muting
PX00	1	1	1	1	YK403H1220	PX00 - FUNC./SIGNAL STRENGTH LED CIRCUIT BOARD P.W. Board, Func./Signal Strength LED
	1	1	1	1	ZZ403H1220	P.W. Board, Assembly
CX01	1	1	1	1	EA10505030	PX00-CAPACITORS Elect 1μF 50V
CX02	1	1	1	1	DA15510010	Ceramic 51pF ±5%
RX02	1	1	1	1	GD05102140	PX00-RESISTORS (All Resistors are ±5% & ¼W) 1kΩ
RX03	1	1	1	1	GD05153140	15kΩ
RX04	1	1	1	1	GD05183140	18kΩ
RX05	1	1	1	1	GD05104140	100kΩ
RX06	1	1	1	1	GD05102140	1kΩ
RX07	1	1	1	1	GD05102140	1kΩ
RX08	1	1	1	1	GD05102140	1kΩ
RX09	1	1	1	1	GD05102140	1kΩ
RX10	1	1	1	1	GD05102140	1kΩ
RX11	1	1	1	1	GD05821140	820Ω
RX12	1	1	1	1	GD05821140	820Ω

REF. DESIG.	Q'TY				PART NO.	DESCRIPTION
	U	C	N	A		
QX01	1	1	1	1	HC10042030	PX00-SEMICONDUCTORS IC LB1415
QX02	1	1	1	1	HI10007320	L.E.D GL9PR9
QX03	1	1	1	1	HI10007320	L.E.D GL9PR9
QX04	1	1	1	1	HI10007320	L.E.D GL9PR9
QX05	1	1	1	1	HI10007320	L.E.D GL9PR9
QX06	1	1	1	1	HI10007320	L.E.D GL9PR9
QX07	1	1	1	1	HI10008030	L.E.D SLP141B
QX08	1	1	1	1	HI10011030	L.E.D SLP241B
QX09	1	1	1	1	HI10011030	L.E.D SLP241B

W01-99	Assembly and Wiring
T01-99	Adjustment
X01-00	Correction

10. TECHNICAL SPECIFICATIONS

FM TUNER SECTION

Frequency Range	87.5 ~ 108 MHz
Usable Sensitivity 40 kHz Deviation, 98 MHz	
Mono S/N 26 dB, 75 ohms	1.0 μ V
Stereo S/N 46 dB, 75 ohms	30 μ V
Alternate Channel Selectivity 98 MHz	65 dB
Image Response Rejection, 98 MHz	55 dB
IF Rejection, 98 MHz	80 dB
Spurious Response Rejection, 98 MHz	85 dB
AM Suppression, 98 MHz	46 dB
Signal-to-Noise Ratio at 98 MHz	
Un-weighted Mono	70 dB
Stereo	63 dB
Weighted Mono	73 dB
Stereo	66 dB
Pilot Signal & Subcarrier Rejection	
19 kHz	60 dB
38 kHz	65 dB
Total Harmonic Distortion at 98 MHz	
Mono	0.2%
Stereo	0.35%
Frequency Response	
30 Hz ~ 15 kHz	+0/- 1 dB
Separation	
Stereo	43 dB
Channel Balance	0.3 dB
Output Voltage, 1 kHz	700 mV
Output Impedance, 1 kHz	1.8k ohms
Acceptable Load Impedance, 1 kHz	47k ohms
Antenna Terminals	
Balanced	300 ohms
Unbalanced	75 ohms

MW TUNER SECTION

Frequency Range	525 ~ 1602 kHz
Usable Sensitivity (20 dB S/N 30% Mod., 1 MHz)	10 μ V
Selectivity 1 MHz	30 dB
Image Rejection, 1 MHz	45 dB
IF Rejection, 1 MHz	40 dB
Signal-to-Noise Ratio, 1 MHz	55 dB
Total Harmonic Distortion, 1 MHz	0.4%

GENERAL

Power Requirements	220V AC, 50 Hz
	(E and N versions are featuring an external voltage selector for use on 110V. Other versions can be converted by a qualified technician to operate on 240V.)
Power Consumption	9 W
Semiconductor Coplement	
Integrated Circuits	4
Transistors	18
Diodes	9
Field Effect Transistors	1
Dimensions	
Panel Width	416 mm
Panel Height	73 mm
Depth	194 mm
Weight	
Unit Alone	2.9 kg

Specifications and appearance are subject to change for modification without notice.

Note

6. SCHEMATIC DIAGRAMS

- Q401 HC10041030
- Q402 HV200006120
- Q403 HF200051D0
- Q404 HT3000471C0
- Q405 HT300051B1C0
- Q406 ~ Q408 H0200001210
- Q409, Q410, Q411 HT107332A0
- Q412, Q413 HC10029010
- Q414 HT107332A0
- Q415 HT107332A0
- Q416 HT107332A0
- Q417 HT107332A0
- Q418 HT107332A0
- Q419 HT107332A0
- Q420 HT107332A0
- Q421 HT107332A0
- Q422 HT107332A0
- Q423 HT107332A0
- Q424 HT107332A0
- Q425 HT107332A0
- Q426 HT107332A0
- Q427 HT107332A0
- Q428 HT107332A0
- Q429 HT107332A0
- Q430 HT107332A0
- Q431 HT107332A0
- Q432 HT107332A0
- Q433 HT107332A0
- Q434 HT107332A0
- Q435 HT107332A0
- Q436 HT107332A0
- Q437 HT107332A0
- Q438 HT107332A0
- Q439 HT107332A0
- Q440 HT107332A0
- Q441 HT107332A0
- Q442 HT107332A0
- Q443 HT107332A0
- Q444 HT107332A0
- Q445 HT107332A0
- Q446 HT107332A0
- Q447 HT107332A0
- Q448 HT107332A0
- Q449 HT107332A0
- Q450 HT107332A0

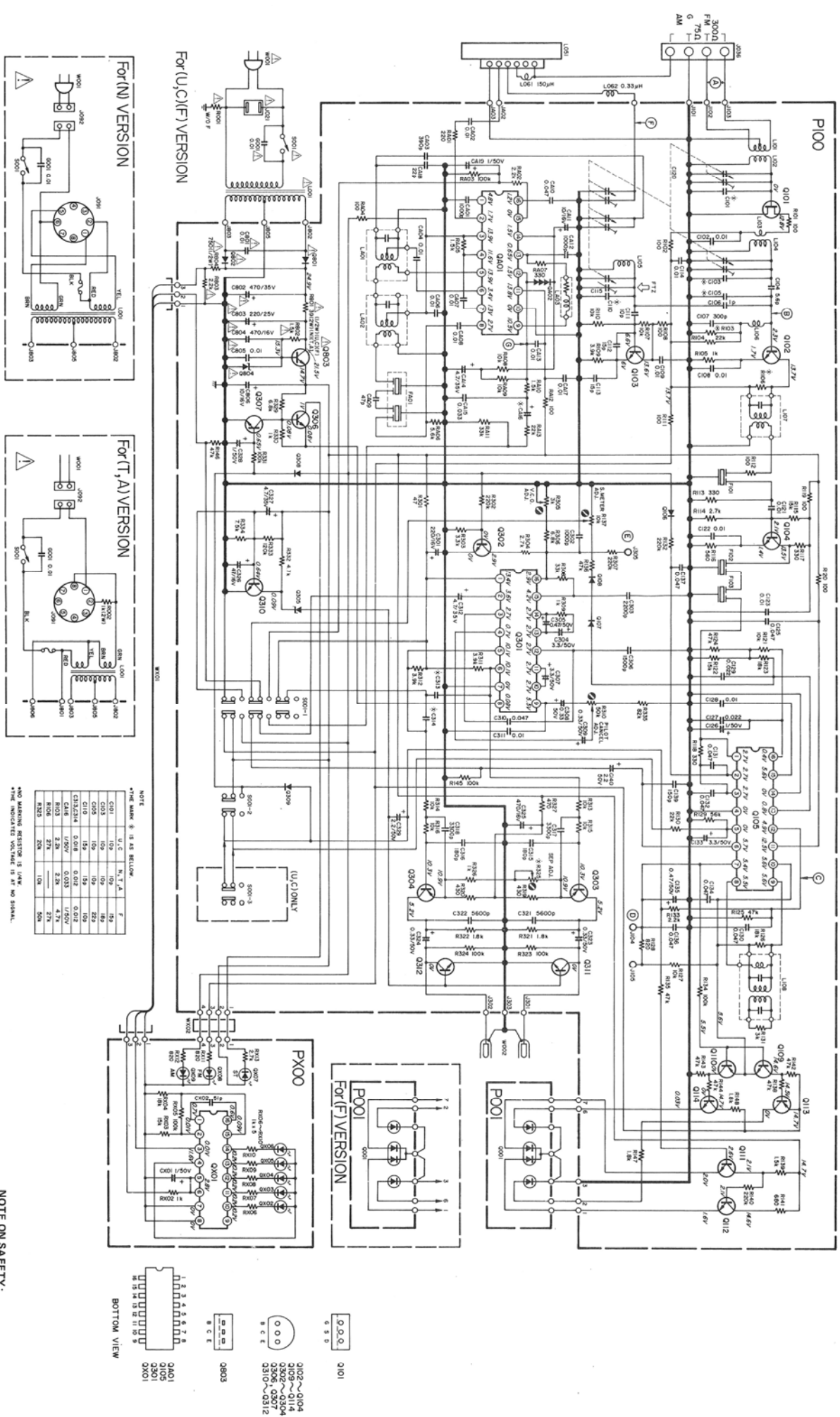

NOTE

*THE MARK # IS AS BEFORE.

C101	U.C.	N.T.A.	F
C102	10	10	10
C103	10	10	10
C104	10	10	10
C105	10	10	10
C106	10	10	10
C107	10	10	10
C108	10	10	10
C109	10	10	10
C110	10	10	10
C111	10	10	10
C112	10	10	10
C113	10	10	10
C114	10	10	10
C115	10	10	10
C116	10	10	10
C117	10	10	10
C118	10	10	10
C119	10	10	10
C120	10	10	10
C121	10	10	10
C122	10	10	10
C123	10	10	10
C124	10	10	10
C125	10	10	10
C126	10	10	10
C127	10	10	10
C128	10	10	10
C129	10	10	10
C130	10	10	10
C131	10	10	10
C132	10	10	10

**NO MARKING RESISTOR IS HAVE NO SIGNAL.

***THE COMPONENTS SYMBOL IS AS IT IS.

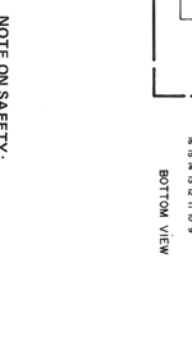



marantz®

MARANTZ CO., INC. · P.O. BOX 577 · CHATSWORTH, CALIFORNIA · 91311



A WHOLLY-OWNED SUBSIDIARY OF SUPERSCOPE INC., CHATSWORTH, CALIFORNIA · 91311