

Service Manual

ST4000/N1B

Tuner

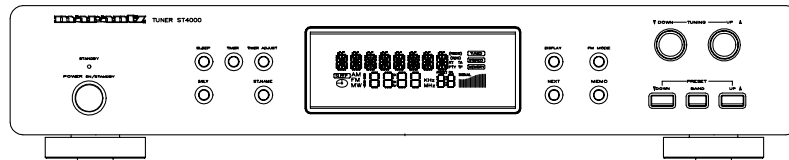

TABLE OF CONTENTS

1.	TECHNICAL SPECIFICATIONS	1
2.	WIRING DIAGRAM	2
3.	BLOCK DIAGRAM	3
4.	SCHEMATIC DIAGRAM AND PARTS LOCATION	5
5.	MICROPROCESSOR AND IC DATA	11
6.	ADJUSTMENT PROCEDURE	13
7.	EXPLODED VIEW AND PARTS LIST	16
8.	ELECTRICAL PARTS LIST	17

Please use this service manual with referring to the user guide (D.F.U) without fail.

marantz®

- ST4000 -

MARANTZ DESIGN AND SERVICE

Using superior design and selected high grade components, **MARANTZ** company has created the ultimate in stereo sound. Only original **MARANTZ** parts can insure that your **MARANTZ** product will continue to perform to the specifications for which it is famous.

Parts for your **MARANTZ** equipment are generally available to our National Marantz Subsidiary or Agent.

ORDERING PARTS :

Parts can be ordered either by mail or by Fax.. In both cases, the correct part number has to be specified.

The following information must be supplied to eliminate delays in processing your order :

1. Complete address
2. Complete part numbers and quantities required
3. Description of parts
4. Model number for which part is required
5. Way of shipment
6. Signature : any order form or Fax. must be signed, otherwise such part order will be considered as null and void.

<p>USA MARANTZ AMERICA, INC. 440 MEDINAH ROAD ROSELLE, ILLINOIS 60172 USA PHONE : 630 - 307 - 3100 FAX : 630 - 307 - 2687</p>	<p>EUROPE / TRADING MARANTZ EUROPE B.V. P.O.BOX 80002, BUILDING SFF2 5600 JB EINDHOVEN THE NETHERLANDS PHONE : +31 - 40 - 2732241 FAX : +31 - 40 - 2735578</p>	<p>BRAZIL MARANTZ BRAZIL CAIXA POSTAL 21462 CEP 04698-970 SAO PAULO, SP, BRAZIL PHONE : 0800 - 123123(Discagem Direta Gratuita) FAX : +55 11 534. 8988</p>
<p>PROFESSIONAL AMERICAS SUPERSCOPE TECHNOLOGIES, INC. MARANTZ PROFESSIONAL PRODUCTS 2640 WHITE OAK CIRCLE, SUITE A AURORA, ILLINOIS 60504 USA PHONE : 630 - 820 - 4800 FAX : 630 - 820 - 8103</p>	<p>CANADA LENBROOK INDUSTRIES LIMITED 633 GRANITE COURT, PICKERING, ONTARIO L1W 3K1 CANADA PHONE : 905 - 831 - 6333 FAX : 905 - 831 - 6936</p>	
<p>AUSTRALIA JAMO AUSTRALIA PTY LTD 1 EXPO COURT, P.O. BOX 350 MT. WAVERLEY VIC 3149 AUSTRALIA PHONE : +61 - 3 - 9543 - 1522 FAX : +61 - 3 - 9543 - 3677</p>	<p>THAILAND MRZ STANDARD CO.,LTD 746 - 754 MAHACHAI ROAD., WANGBURAPAPIROM, PHRANAKORN, BANGKOK, 10200 THAILAND PHONE : +66 - 2 - 222 9181 FAX : +66 - 2 - 224 6795</p>	<p>SINGAPORE WO KEE HONG (S) PTE LTD WO KEE HONG CENTRE NO.23, LORONG 8, TOA PAYOH SINGAPORE 319257 PHONE : +65 2544555 FAX : +65 2502213</p>
	<p>TAIWAN PAI- YUING CO., LTD. 6 TH FL NO, 148 SUNG KIANG ROAD, TAIPEI, 10429, TAIWAN R.O.C. PHONE : +886 - 2 - 25221304 FAX : +886 - 2 - 25630415</p>	<p>MALAYSIA WO KEE HONG ELECTRONICS SDN. BHD. NO. 102 JALAN SS 21/35, DAMANSARA UTAMA, 47400 PETALING JAYA SELANGOR DARUL EHSAN, MALAYSIA PHONE : +60 3 - 7184666 FAX : +60 3 - 7173828</p>
<p>JAPAN Technical MARANTZ JAPAN, INC. 35- 1, 7- CHOME, SAGAMIONO SAGAMIHARA - SHI, KANAGAWA JAPAN 228-8505 PHONE : +81 42 748 1013 FAX : +81 42 748 9190</p>	<p style="text-align: center;">日本マランツ株式会社</p> <p>本社 〒228-8505 神奈川県相模原市相模大野7-35-1 営業本部 〒150-0022 東京都渋谷区恵比寿南1-11-9</p>	<p>KOREA MK ENTERPRISES LTD. ROOM 604/605, ELECTRO-OFFICETEL, 16-58, 3GA, HANGANG-RO, YONGSAN-KU, SEOUL KOREA PHONE : +822 - 3232 - 155 FAX : +822 - 3232 - 154</p>

SHOCK, FIRE HAZARD SERVICE TEST :

CAUTION : After servicing this appliance and prior to returning to customer, measure the resistance between either primary AC cord connector pins (with unit NOT connected to AC mains and its Power switch ON), and the face or Front Panel of product and controls and chassis bottom.

Any resistance measurement less than 1 Megohms should cause unit to be repaired or corrected before AC power is applied, and verified before it is return to the user/customer.

Ref. UL Standard No. 1492.

In case of difficulties, do not hesitate to contact the Technical Department at above mentioned address.

1. TECHNICAL SPECIFICATIONS

FM Section

Tuning Range	87.5 MHz - 108.0 MHz
Usable Sensitivity (IHF) Mono	10 dBf
50 dB Quieting sensitivity	
Mono	17 dBf
Stereo	33 dBf
Alternate Channel Selectivity (98 MHz \pm 400 kHz)	65 dB
Image Response Ratio	60 dB
Frequency Response	20 Hz - 15 kHz, +0.5 dB/-3 dB
Capture Ratio	2 (at 98 MHz)
Distortion (at 65 dBf, 98 MHz)	
Mono	0.2 %
Stereo	0.3 %
Signal-to-Noise Ratio (at 65 dBf, 1 kHz)	
Mono	70 dB
Stereo	65 dB
AM Suppression Ratio	80 dB
Stereo Separation (1 kHz)	40 dB
Output (Level/Impedance)	600 mV/2.2 k ohm

AM Section

Tuning Range	522 kHz - 1,620 kHz (9 kHz steps)
Usable Sensitivity (IHF)	55 dB/m (562 μ V/m, Loop Antenna)
Selectivity	30 dB (at \pm 9 kHz)
Image Response Ratio	35 dB
IF Response Ratio	60 dB
Distortion	1 % (at 85 dB/m)
Signal-to-Noise Ratio	50 dB (at 94 dB/m)
Output (Level/Impedance)	170 mV/2.2 k ohm

General

Power Requirements	230V AC, 50 Hz
Power Consumption	6 W
MAX Dimensions (W x H x D)	440 x 86 x 290 mm
Weight (net)	3.0 kg
Accessories	
AM Loop Antenna x 1, FM Antenna x 1	
PCA pin plug cord x 1, Remote control Cable x 1	

Improvements may result in specifications and features changing without notice.

2. WIRING DIAGRAM

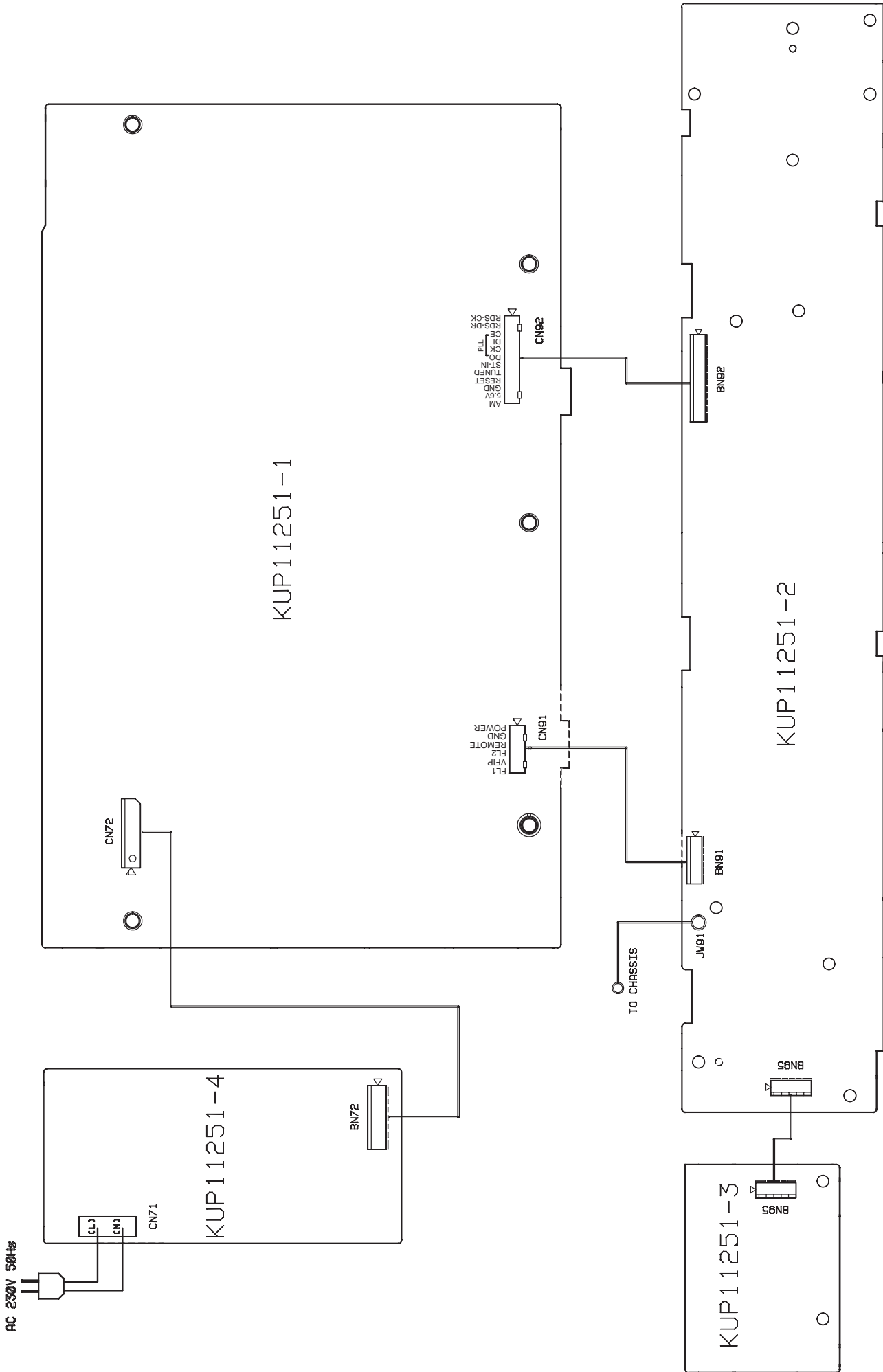

3. BLOCK DIAGRAM

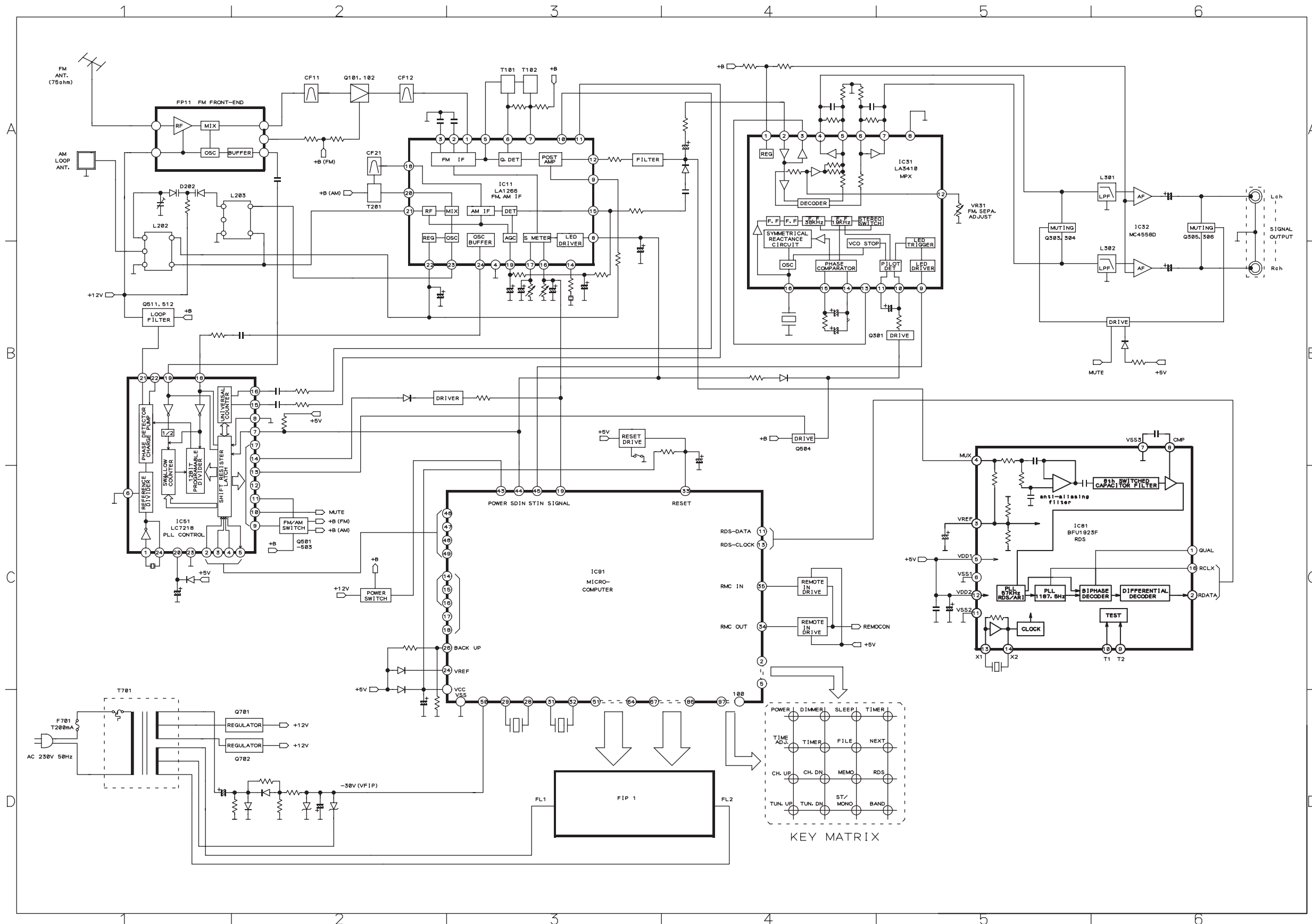

4. SCHEMATIC DIAGRAMS AND PARTS LOCATIONS

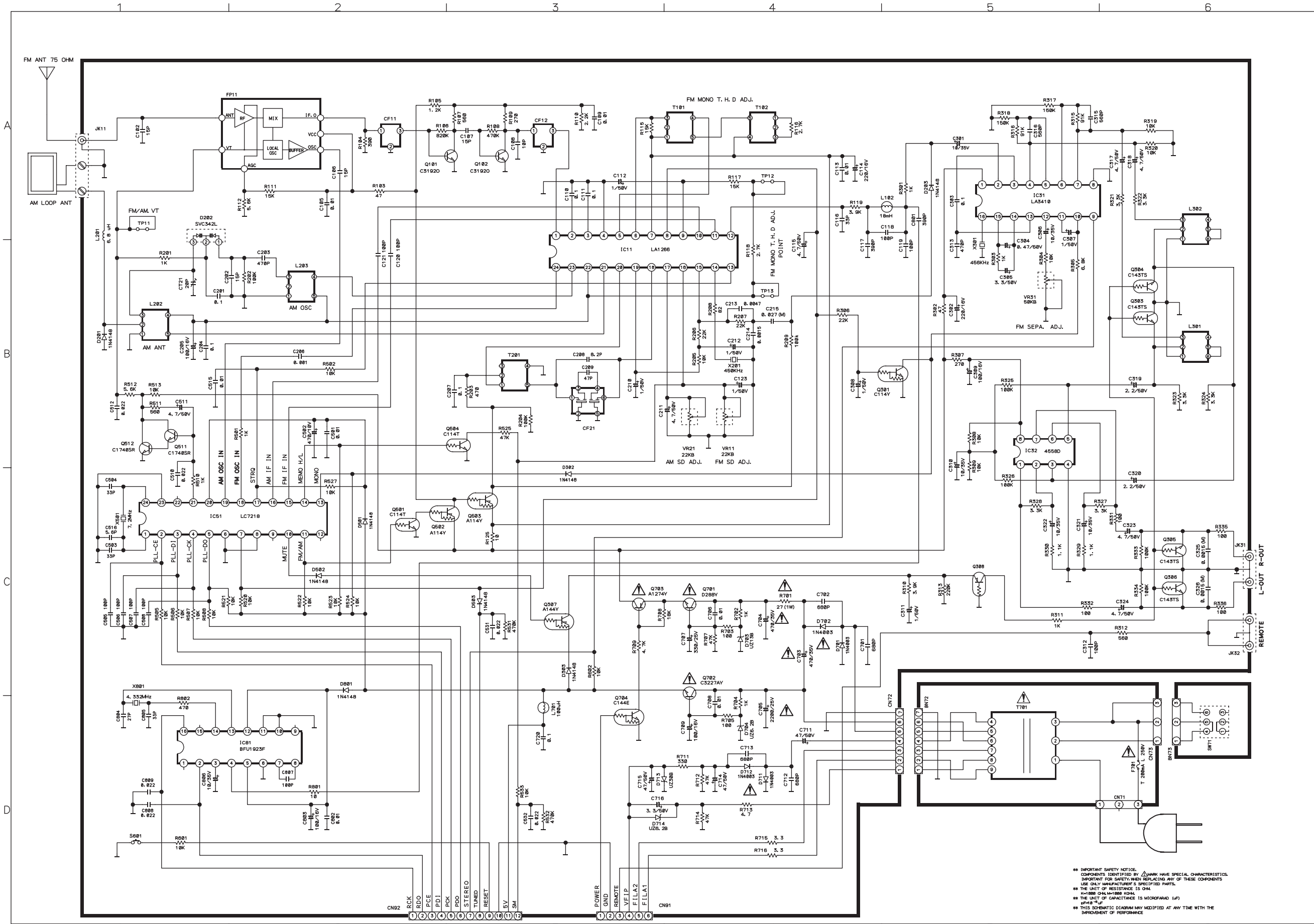

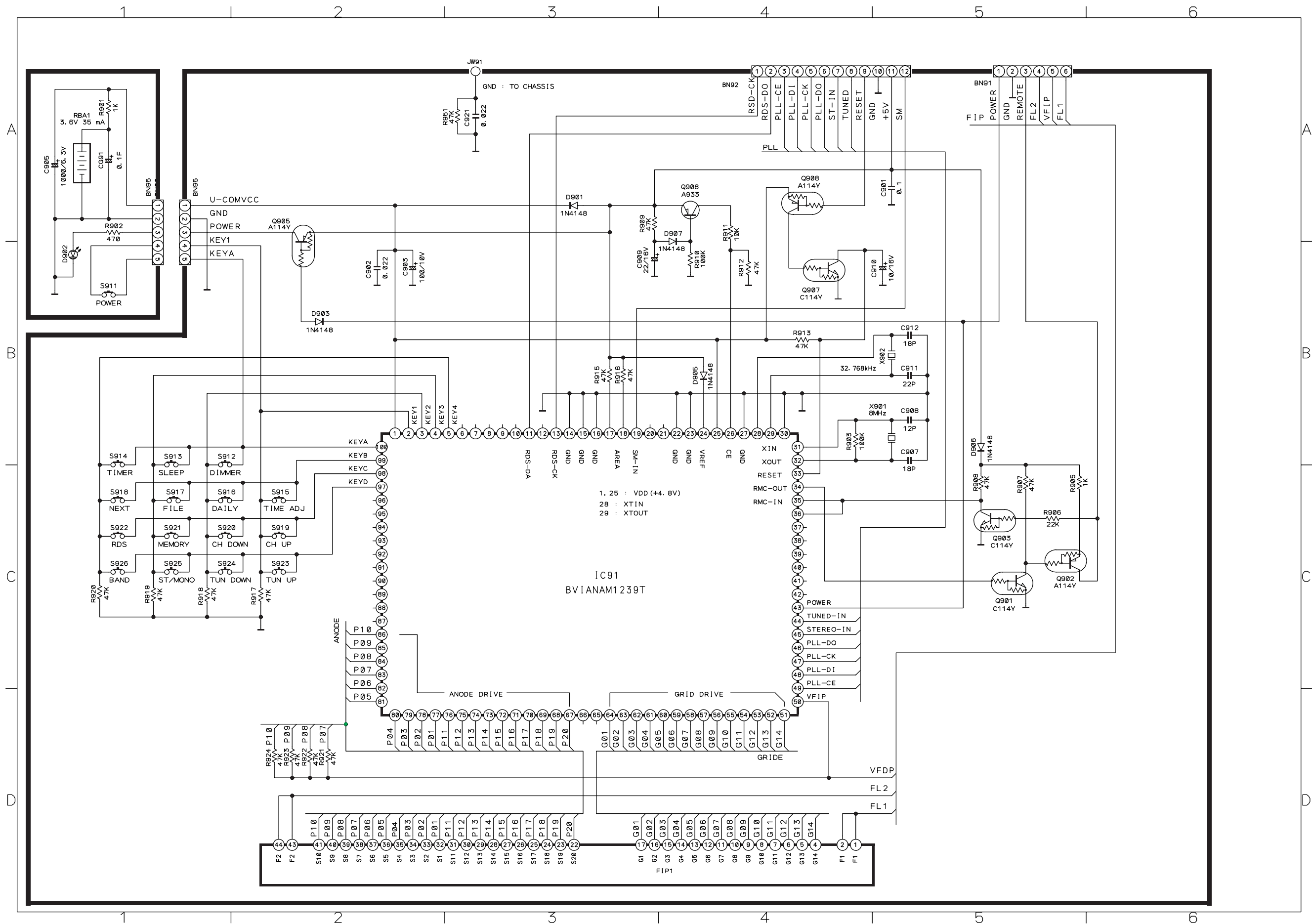

Q701 Q703 Q307 Q308 IC81 Q305 Q306 Q503 Q504 IC11 Q502 Q102 IC51 Q101
 Q702 Q704 Q304 Q303 IC31 Q301 Q511 Q512

CUP11251

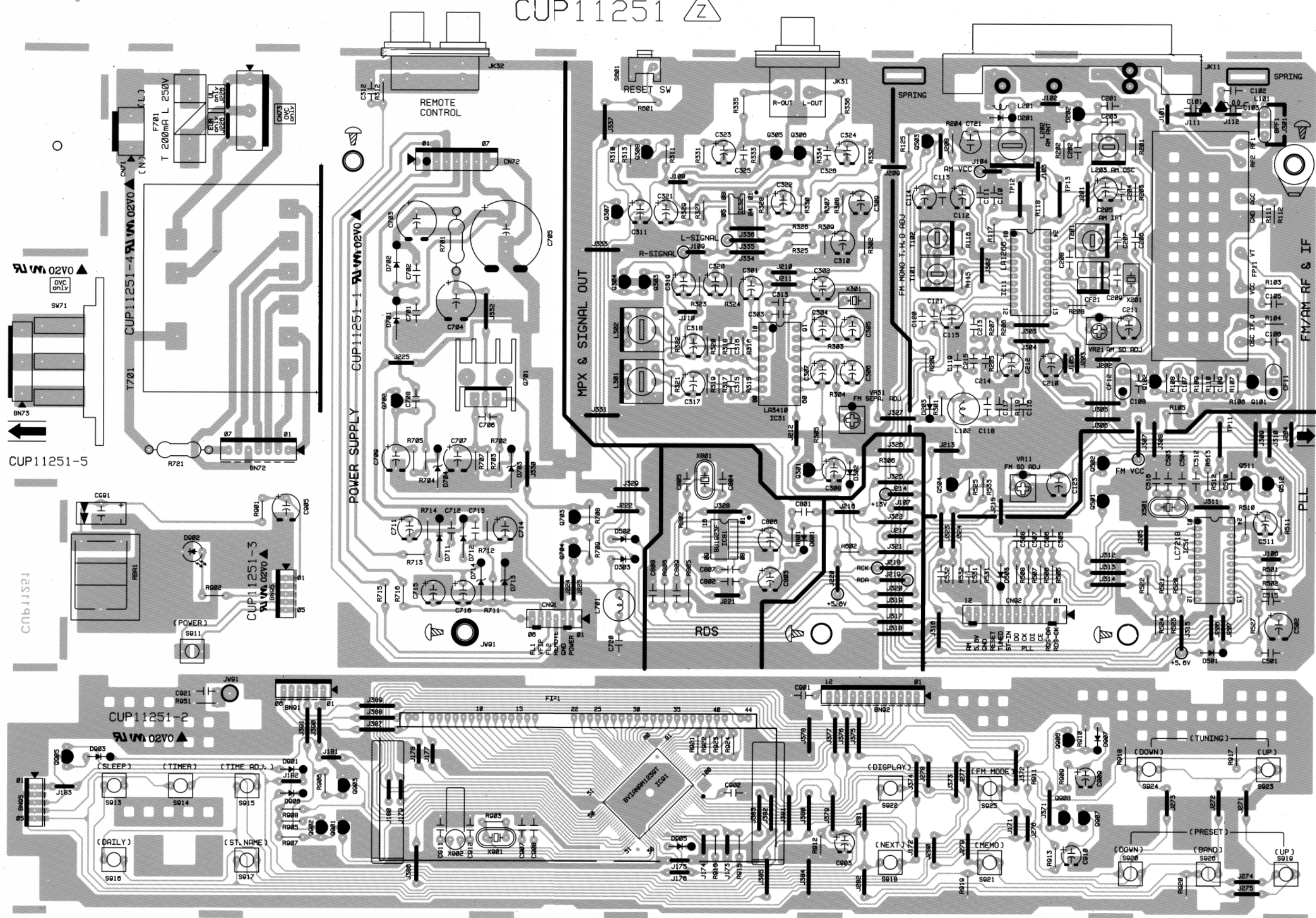

9988

Q905

Q902 Q901 Q903

IC91

Q906
Q908 Q907

5. MICROPROCESSOR AND IC DATA

1. Block Diagram

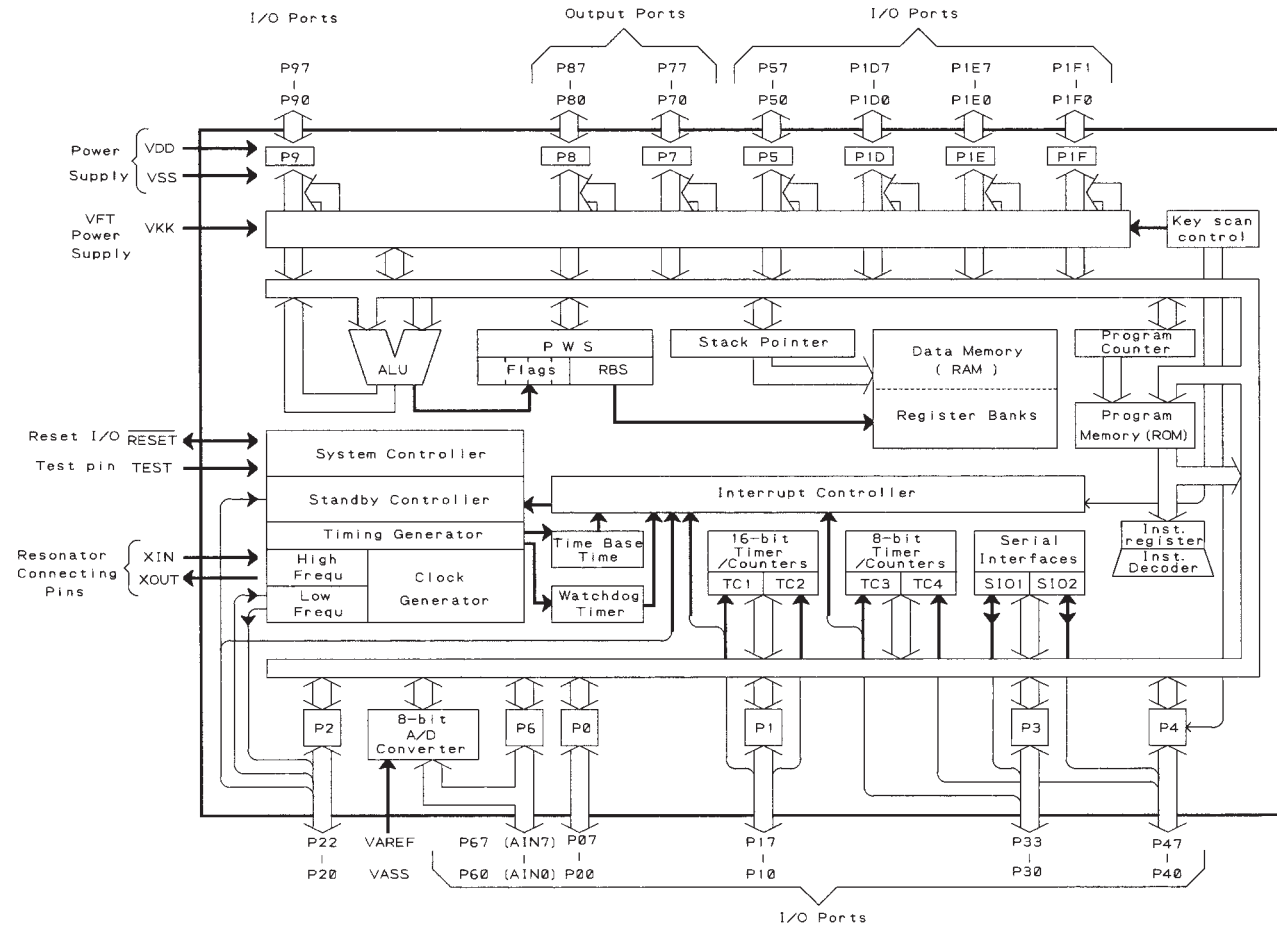

IC51 : BVILC7218 (LC7218)

PIN NO.	IN/OUT	MARK	DESCRIPTION OF TERMINAL
1	INPUT	XIN	Connecting terminal for crystal oscillator(7.2MHz)
2	INPUT	CE	Chip enable terminal for serial data input/output.
3	INPUT	DI	Data input terminal for control
4	INPUT	CL	Clock input terminal for control
5	OUTPUT	DO	Data output terminal for control
6	INPUT	SYS	Not used in this unit.(0 V)
7	INPUT	IN0	Control input for data format
8	INPUT	IN1	
9	OUTPUT	OUT0	Not used in this unit.
10	OUTPUT	OUT1	MUTE ON: "H" , MUTE OFF: "L"
11	OUTPUT	OUT2	FM : "H" , AM : "L"
12	OUTPUT	OUT3	Not used in this unit.
13	OUTPUT	OUT4	STEREO : "L" , MONO : "H"
14	OUTPUT	OUT5	Signal indicator driver
15	INPUT	LCTR	Input terminal for IF detector
16	INPUT	HCTR	
17	OUTPUT	OUT6	Output terminal for IF detector
18	INPUT	AM IN	Input for AM OSC output
19	INPUT	FM IN	Input for FM OSC output
20	INPUT	VDD	Power supply terminal
21	OUTPUT	PD1	Output terminal for PLL charge pump.
22	OUTPUT	PD2	Not used in this unit.
23	-	VSS	Ground terminal
24	OUTPUT	XOUT	Connecting terminal for crystal oscillator(7.2MHz)

IC91 : ANAM 1239T

PIN NO.	SYMBOL	IN/OUT	DESCRIPTION
1	VCC	I	VDD CONNECTION
2-5	KEY OUT	O	KEY MATRIX OUTPUT
6-10	N.C		NO CONNECTION
11	RDS DATA	I	RDS DATA INPUT
12	N.C		NO CONNECTION
13	RDS CK	I	RDS CLOCK INPUT
14-16	GND		GROUND
17,18	AREA OPTION	I	17(H), 18(H) : EUROPE OPTION
19	SIGNAL	I	SIGNAL INPUT
20,21	N.C		NO CONNECTION
22,23	GND		GROUND
24	VREF	I	5V VDD
25	VCC	I	VDD CONNECTION
26	CE	I	MICOM CHIP ENABLE
27	GND		GROUND
28	TX	I	32.768KHz CRISTAL TIME OPERATOR
29	TEX	O	
30	GND		GROUND
31	XIN	I	8.0MHz CRYSTAL MICOM OPERATOR
32	XOUT	O	
33	RESET	I	RESET INPUT
34	RMC-OUT	O	REMOCON DATA OUTPUT
35,36	RMC-IN	I	REMOCON DATA INPUT
37-42	N.C		NO CONNECTION
43	POWER	O	TUNER POWER ON/OFF
44	TUNED	I	TUNED DISPLAY INPUT
45	STEREO	I	STEREO DISPLAY INPUT
46	PLL DO	O	PLL SERIAL DATA OUTPUT
47	PLL CK	O	PLL SERIAL CLOCK OUTPUT
48	PLL DI	I	PLL SERIAL DATA INPUT
49	PLL CE	O	PLL SERIAL CHIP ENABLE OUTPUT
50	VFIP	I	FIP VDD : 30V
51-64	G01-G14	O	FIP GRIDE SIGNAL OUTPUT
65,66	N.C		NO CONNECTION
67-86	P01-P20	O	FIP ANODE SIGNAL OUTPUT
87-96	N.C		NO CONNECTION
97-100	KEY IN	I	KEY MATRIX INPUT

6. ADJUSTMENT PROCEDURE

(1) ALIGNMENT INSTRUCTIONS

EQUIPMENT NEEDED/IMPORTANT

- * AM Signal Generator 1. Check power-source voltage.
- * FM Signal Generator 2. Set the function switch to band aligned.
- * Oscilloscope 3. Keep the function input as low as possible to adjust.
- * VTVM (AC, DC) accurately.
- * Test loop antenna (MW Adjustment) 4. Modulation and modulation frequency.
Dummy antenna (FM Adjustment)
- * Stereo signal modulator.
- * Distortion analyzer Modulation Modulation Frequency.

EQUIPMENT NEEDED/IMPORTANT

- * AM Signal Generator 1. Check power-source voltage.
- * FM Signal Generator 2. Set the function switch to band aligned.
- * Oscilloscope 3. Keep the function input as low as possible to adjust.
- * VTVM (AC, DC) accurately.
- * Test loop antenna (MW Adjustment) 4. Modulation and modulation frequency.

	MODULATION	MODULATION FREQUENCY
MW	30%	400Hz
FM	100% (75KHz)	400Hz

(2) TUNING FREQUENCY RANGE ADJUSTMENT

(FM) DC VOLTMETER

- * CONNECT TO TEST POINT TP1 and GND

(MW) DC VOLTMETER

- * CONNECT TO TEST POINT TP1 and GND

NO	BAND	FREQUENCY	ADJUST FOR	ADJUSTMENT
1	FM	87.50MHz	1.5V	L4
2	MW	522KHz	1V	L103

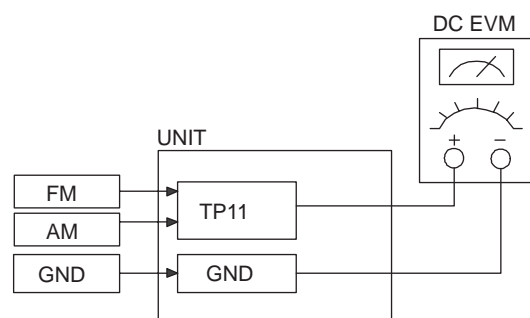

(3) MW TRACKING ADJUSTMENT

Signal Generator : Connects to the MW Ant.

Coil through the loop antenna.

Adjust for the indication of VTVM of the wave form of scope to be maximum.

NO	STEP	FREQUENCY	ADJUST FOR	ADJUSTMENT
MW	1	612KHz	Max sensitivity	L102
	2	1503KHz	Max sensitivity	CT01
	3	Repeat steps 1 and 2 several times.		

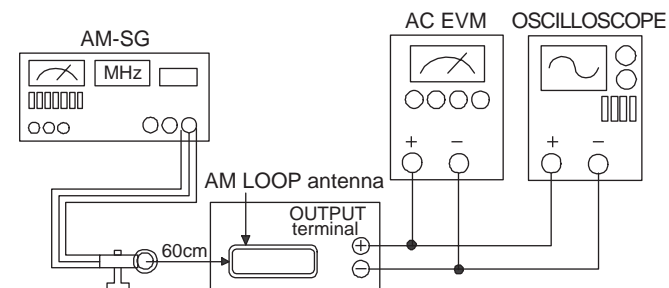

(4) FM-RF ADJUSTMENT

Signal Generator : Connects to FM ANT. JACK (FM IN) through the dummy.

NO	FREQUENCY	ADJUST FOR	ADJUSTMENT
1	90.10MHz	Max sensitivity	L1, L2, L3
2	Repeat step 1 several times		

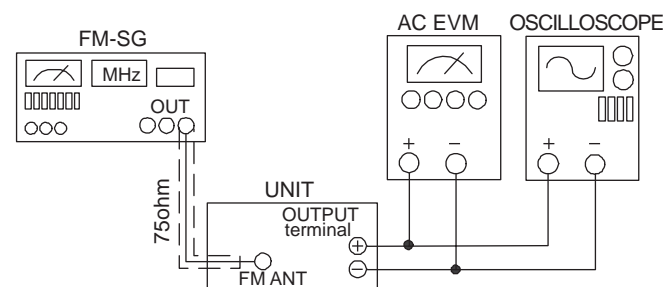

(5) FM MONO DISTORTION ADJUSTMENT

DC VOLTMETER

- * Connect to TP02 (-), TP03 (+) through the choke coil (100μH).

Signal Generator

- * Connect to FM ANT. Jack (FM IN) through the dummy.

Distortion Meter

- * Connect to the output.

NO	FREQUENCY	ADJUST FOR	ADJUSTMENT
1	100.10MHz	DC Voltmeter 0V	T101
2	100.10MHz	min T.H.D	T102
3	Repeat steps 1 and 2 several times		

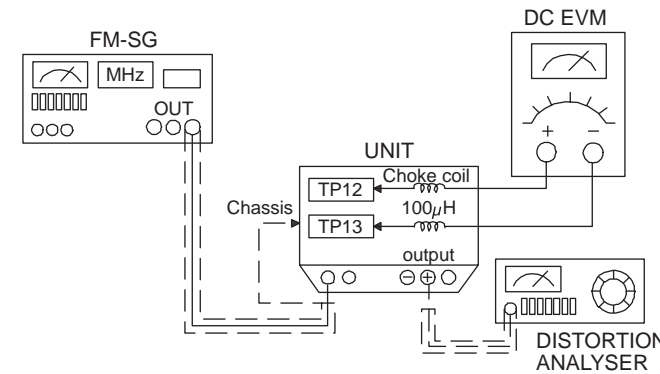

(7) FM/MW TUNED LEVEL ADJUSTMENT

FM Signal Generator : Connect to FM ANT. Jack (FM IN) through the dummy.

MW Signal Generator : Connect to MW ANT. Coil through Loop antenna.

BAND	STEP	SIGNAL GENERATOR	ADJUST FOR	ADJUSTMENT
FM	1	100.10MHz 30dB	TUNED ON	VR02
	2	100.10MHz 30dB	TUNED OFF	VR02
MW	1	999KHz 80dB	TUNED ON	VR01
	2	999KHz 80dB	TUNED OFF	VR01

(6) FM STEREO SEPARATION

PILOT SIGNAL	ADJUST FOR	ADJUSTMENT
ON	Different of R and L Must be maximum	VR03

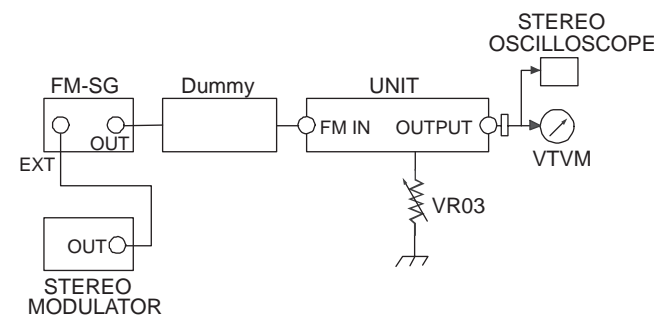

ADJUSTMENT POINT

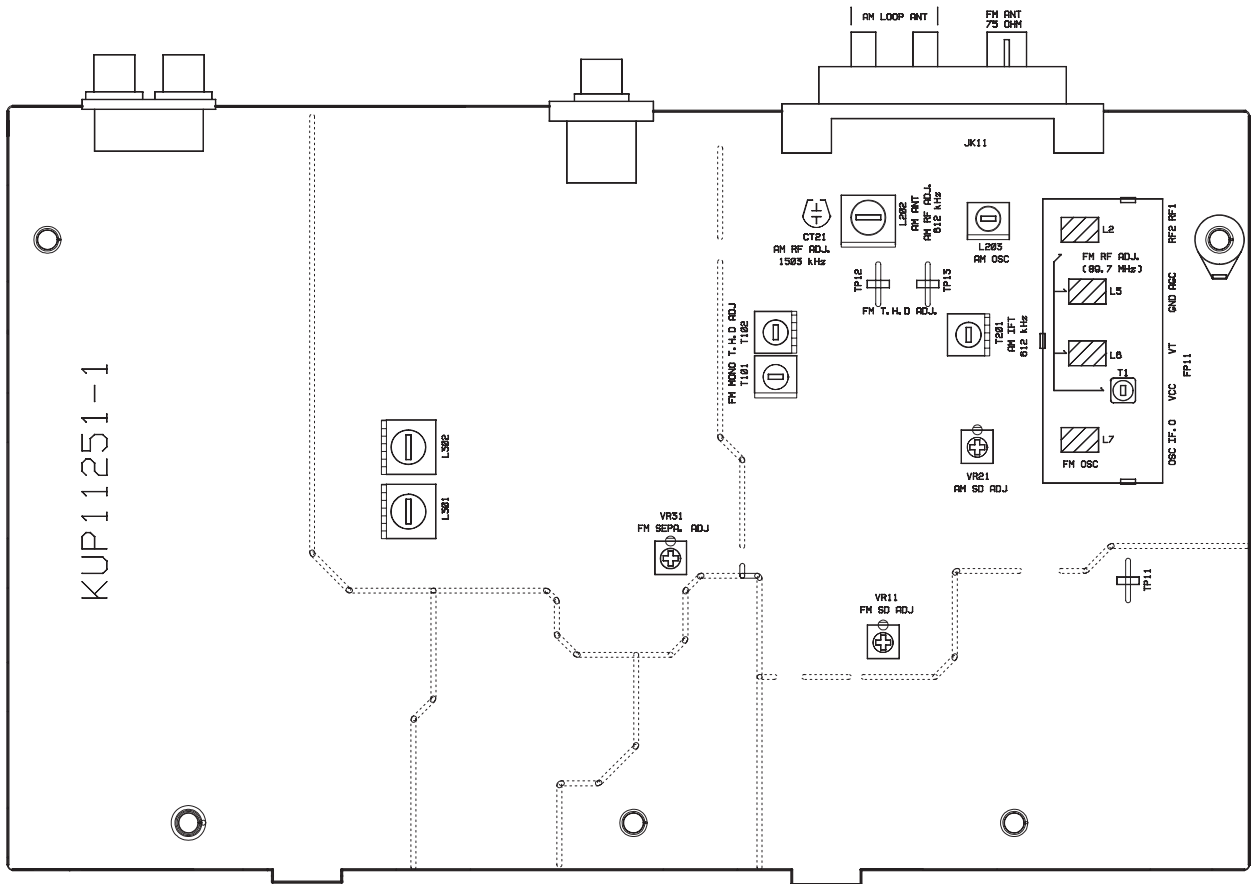

7. EXPLODED VIEW AND PARTS LIST

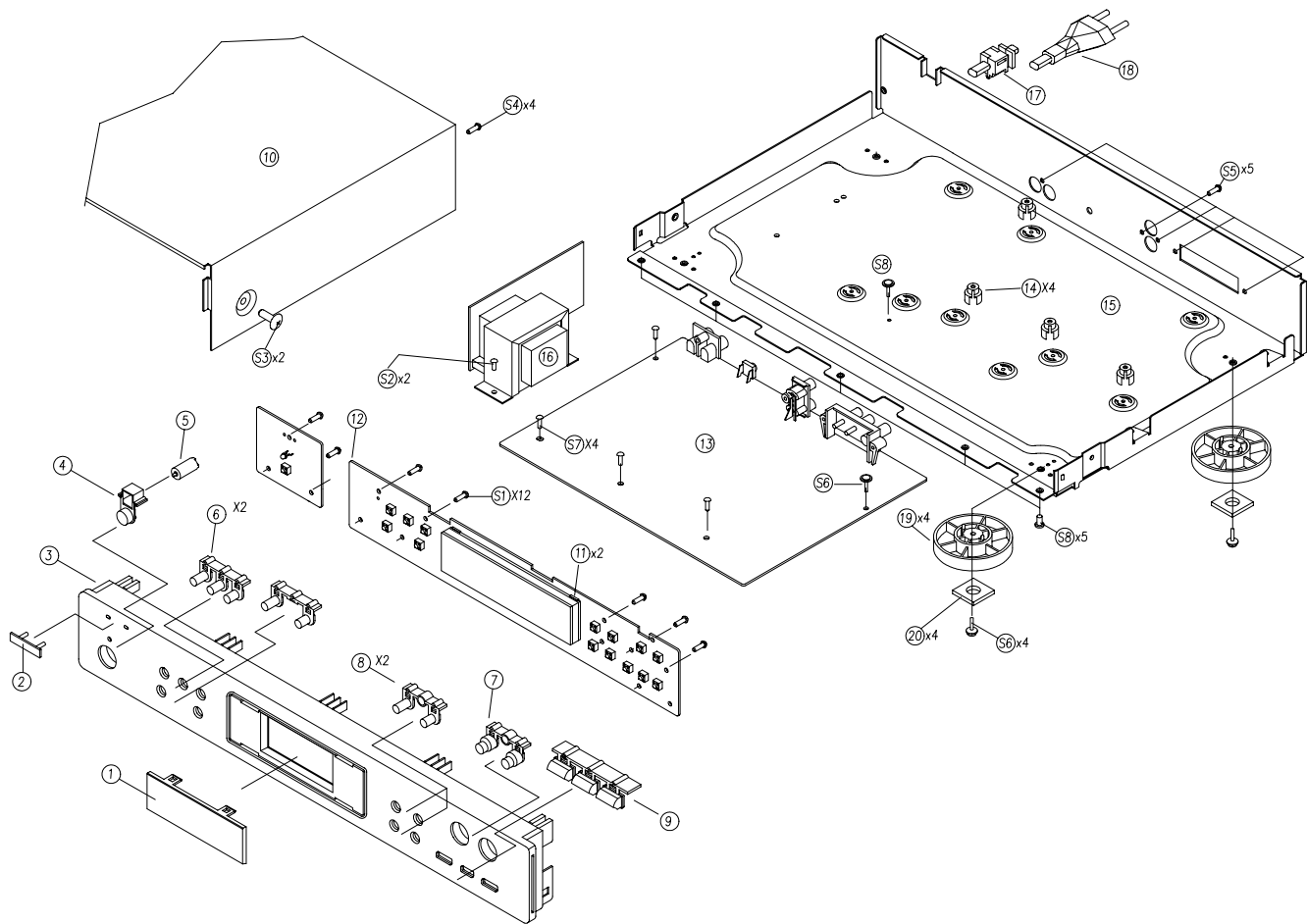

(VERS. :VERSION, U:U.S.A., F:JAPAN, K:FAR EAST, N:EUROPE)

POS. NO	VERS. COLOR	PART NO. (FOR PCS)	DESCRIPTION	PART NO. (MJI)
1		9965 000 01238	WINDOW FIP	281W158010
2		nsp	BADGE MARANTZ	nsp
3		9965 000 01242	PANEL FRONT	281W248010
4		9965 000 01243	KNOB POWER	281W270010
5		9965 000 01244	INDICATOR	285W355010
6		9965 000 01245	KNOB TIMER	281W270050
7		9965 000 01246	KNOB TUNING	281W270030
8		9965 000 01247	KNOB DISPLAY	281W270040
9		9965 000 01248	KNOB PRESET	281W270020
10		nsp	CABINET TOP	nsp
14		nsp	HOLDER PCB	nsp
15		nsp	CHASSIS BOTTOM	nsp
▲ 16		4822 146 10926	TRANS MAINS 230V	*TS000780R
17		nsp	BUSHING MAINS CORD	nsp
18		nsp	MAINS CORD	nsp
19		4822 462 10695	FOOT	168W057010
20		nsp	RUBBER CUSHION	nsp
S1 S8		nsp	SCREW	nsp
001T		9965 000 01249	PACKING MANUAL INSTRUCTION	281W851310
		nsp	ANT FM WIRE	nsp
		nsp	AM LOOP ANT ASS'Y	nsp

8. ELECTRICAL PARTS LIST

ASSIGNMENT OF COMMON PARTS CODES.

RESISTORS

R*** : 1) GD05 x x x 140, Carbon film fixed resistor, ±5% 1/4W
 R*** : 2) GD05 x x x 160, Carbon film fixed resistor, ±5% 1/6W
 ① Resistance value

Examples

① Resistance value
 0.1Ω 001 10Ω 100 1kΩ 102 100kΩ 104
 0.5Ω 005 18Ω 180 2.7kΩ 272 680kΩ 684
 1Ω 010 100Ω 101 10kΩ 103 1MΩ 105
 6.8Ω 068 390Ω 391 22kΩ 223 4.7MΩ 475

Note : Please distinguish 1/4W from 1/6W by the shape of parts used actually.

CAPACITORS

C*** : CERAMIC CAP.

3) DD1 x x x x 370, Ceramic capacitor
 Disc type
 Temp. coeff. P350~N1000, 50V
 ③ Capacity value
 ② Tolerance

Examples

② Tolerance (Capacity deviation)

±0.25 pF 0
 ±0.5 pF 1
 ±5 % 5

Tolerance of COMMON PARTS handled here are as follows :

0.5 pF - 5 pF ± 0.25 pF
 6 pF - 10 pF ± 0.5 pF
 12 pF - 560 pF ... ± 5 %

③ Capacity value

0.5 pF 005 3 pF 030 100 pF 101
 1 pF 010 10 pF 100 220 pF 221
 1.5 pF 015 47 pF 470 560 pF 561

C*** : CERAMIC CAP.

4) DK16 x x x 300, High dielectric constant ceramic capacitor
 Disc type
 Temp. chara. 2B4, 50V
 ④ Capacity value

Examples

④ Capacity value

100 pF 101 1000 pF 102 10000 pF 103
 470 pF 471 2200 pF 222

C*** : 5) ELECTROLY CAP. (), 6) FILM CAP ()

5) EA x x x x x 10, Electrolytic capacitor
 One-way lead type, Tolerance ±20%
 ⑥ Working voltage
 ⑤ Capacity value

Examples

⑤ Capacity value

0.1 μF 104 4.7 μF 475 100 μF 107
 0.33 μF 334 10 μF 106 330 μF 337
 1 μF 105 22 μF 226 1100 μF 118
 2200 μF 228

⑥ Working voltage

6.3 V 006 25 V 025
 10 V 010 35 V 035
 16 V 016 50 V 050

6) DF15 x x x 350 → Plastic film capacitor
 DF15 x x x 310 → One-way type, Mylar ±5% 50V
 DF16 x x x 310 → Plastic film capacitor
 One-way type, Mylar ±10% 50V
 ⑦ Capacity value

Examples

⑦ Capacity value

0.001 μF (1000 pF) 102 0.1 μF 104
 0.0018 μF 182 0.56 μF 564
 0.01 μF 103 1 μF 105
 0.015 μF 153

NOTE 1) The above CODES (R***, R***, C***, C*** and C***) are omitted on the schematic diagram in some case.
 2) On the occasion, be confirmed the common parts on the parts list.
 3) Refer to "Common Parts List" for the other common parts (RI05, DD4, DK4).

NOTE ON SAFETY FOR FUSIBLE RESISTOR :

The suppliers and their type numbers of fusible resistors are as follows ;

1. KOA Corporation

Part No.(MJI)	Type No.(KOA)	Description
NH05 x x x 140	RF25S x x x x Ω	J ±5% (1/4W)
NH05 x x x 120	RF50S x x x x Ω	J ±5% (1/2W)
NH85 x x x 110	RF73B2A x x x x Ω	J ±5% (1/10W)
NH95 x x x 140	RF73B2E x x x x Ω	J ±5% (1/4W)

* Resistance value

Resistance value (0.1Ω - 10kΩ)

2. Matsushita Electronic Components Co., Ltd

Part No.(MJI)	Type No.(MEC)	Description
NF05 x x x 140	ERD-2FCJ x x x	(±5% 1/4W)
RF05 x x x 140		
NF02 x x x 140	ERD-2FCG x x x	(±2% 1/4W)
RF02 x x x 140		

* Resistance value



Examples

* Resistance value
 0.1Ω 001 10Ω 100 1kΩ 102 100kΩ 104
 0.5Ω 005 18Ω 180 2.7kΩ 272 680kΩ 684
 1Ω 010 100Ω 101 10kΩ 103 1MΩ 105
 6.8Ω 068 390Ω 391 22kΩ 223 4.7MΩ 475

ABBREVIATION AND MARKS

ANT. : ANTENNA	BATT. : BATTERY
CAP. : CAPACITOR	CER. : CERAMIC
CONN. : CONNECTING	DIG. : DIGITAL
HP : HEADPHONE	MIC. : MICROPHONE
μ-PRO : MICROPROCESSOR	REC. : RECORDING
RES. : RESISTOR	SPK : SPEAKER
SW : SWITCH	TRANSF. : TRANSFORMER
TRIM. : TRIMMING	TRS. : TRANSISTOR
VAR. : VARIABLE	X' TAL : CRYSTAL

NOTE ON SAFETY:

Symbol  Fire or electrical shock hazard. Only original parts should be used to replaced any part marked with symbol  Any other component substitution (other than original type), may increase risk of fire or electrical shock hazard.

安全上の注意 :

 がついている部品は、安全上重要な部品です。必ず指定されている部品番号の部品を使用して下さい。

(VERS.:VERSION, U:U.S.A., F:JAPAN, K:FAR EAST, N:EUROPE)

POS. NO	VERS. COLOR	PART NO. (FOR PCS)	DESCRIPTION	PART NO. (MJI)
			CAPACITORS	
CF21		4822 242 10853	FILM SFZ450F	FF10045290
CF11		4822 242 11039	FILM SFE10.7MS8H-A-T	*FF100230R
CF12		4822 242 11039	FILM SFE10.7MS8H-A-T	*FF100230R
CG91		4822 124 12129	ELECT 0.1F	*EX000030R
CT21		4822 125 11116	TRIM. VARIABLE	*CT000110R
C102	nsp		CER. 15pF 50V J	nsp
C105	nsp		CER. 0.01 μ F 50V Z	nsp
C106	nsp		CER. 15pF 50V J	nsp
C107	nsp		CER. 15pF 50V J	nsp
C108	nsp		CER. 10pF 50V J	nsp
C109	nsp		CER. 0.01 μ F 50V Z	nsp
C110	nsp		CER. 0.1 μ F 50V Z	nsp
C111	nsp		CER. 0.1 μ F 50V Z	nsp
C112	nsp		ELECT 1 μ F 50V	nsp
C113	nsp		CER. 0.01 μ F 50V Z	nsp
C114	nsp		ELECT 220 μ F 16V	nsp
C115	nsp		ELECT 4.7 μ F 50V	nsp
C116	nsp		CER. 33pF 50V J	nsp
C117	nsp		CER. 390pF 50V K	nsp
C118				
∫	nsp		CER. 100pF 50V K	nsp
C121				
C123	nsp		ELECT 1 μ F 50V	nsp
C201	nsp		CER. 0.1 μ F 50V Z	nsp
C202	nsp		CER. 15pF 50V J	nsp
C203	nsp		CER. 470pF 50V K	nsp
C204	nsp		CER. 0.1 μ F 50V Z	nsp
C205	nsp		ELECT 100 μ F 16V	nsp
C206	nsp		CER. 0.001 μ F 50V K	nsp
C207	nsp		CER. 0.1 μ F 50V Z	nsp
C208	nsp		CER. 8.2pF 50V J	nsp
C209	nsp		CER. 47pF 50V J	nsp
C210	nsp		ELECT 1 μ F 50V	nsp
C211	nsp		ELECT 4.7 μ F 50V	nsp
C212	nsp		ELECT 1 μ F 50V	nsp
C213	nsp		CER. 0.0047 μ F 50V M	nsp
C214	nsp		FILM 0.0015 μ F 50V J	nsp
C215	nsp		FILM 0.027 μ F 50V J	nsp
C301	nsp		ELECT 10 μ F 50V	nsp
C302	nsp		ELECT 220 μ F 16V	nsp
C303	nsp		CER. 0.1 μ F 50V Z	nsp
C304	nsp		ELECT 0.47 μ F 50V	nsp
C305	nsp		ELECT 3.3 μ F 50V	nsp
C306	nsp		ELECT 10 μ F 50V	nsp
C307	nsp		ELECT 1 μ F 50V	nsp
C308	nsp		ELECT 1 μ F 50V	nsp
C309	nsp		ELECT 100 μ F 16V	nsp
C310	nsp		ELECT 10 μ F 50V	nsp
C311	nsp		ELECT 1 μ F 50V	nsp
C312	nsp		CER. 100pF 50V K	nsp
C313	nsp		CER. 470pF 50V K	nsp
C315	nsp		CER. 560pF 50V K	nsp
C316	nsp		CER. 560pF 50V K	nsp
C317	nsp		ELECT 4.7 μ F 50V	nsp
C318	nsp		ELECT 4.7 μ F 50V	nsp
C319	nsp		ELECT 2.2 μ F 50V	nsp
C320	nsp		ELECT 2.2 μ F 50V	nsp
C321	nsp		ELECT 10 μ F 50V	nsp
C322	nsp		ELECT 10 μ F 50V	nsp
C323	nsp		ELECT 4.7 μ F 50V	nsp
C324	nsp		ELECT 4.7 μ F 50V	nsp
C325	nsp		FILM 0.0015 μ F 50V J	nsp
C326	nsp		FILM 0.0015 μ F 50V J	nsp
C501	nsp		CER. 0.01 μ F 50V Z	nsp
C502	nsp		ELECT 470 μ F 10V	nsp
C503	nsp		CER. 33pF 50V J	nsp
C504	nsp		CER. 33pF 50V J	nsp

(VERS.:VERSION, U:U.S.A., F:JAPAN, K:FAR EAST, N:EUROPE)

POS. NO	VERS. COLOR	PART NO. (FOR PCS)	DESCRIPTION	PART NO. (MJI)
C505				
∫		nsp	CER. 100pF 50V K	nsp
C508				
C510		nsp	CER. 0.022 μ F 50V Z	nsp
C511		nsp	ELECT 4.7 μ F 50V	nsp
C512		nsp	CER. 0.022 μ F 50V Z	nsp
C515		nsp	CER. 0.01 μ F 50V Z	nsp
C516		nsp	CER. 5.6pF 50V K	nsp
C531		nsp	CER. 0.022 μ F 50V Z	nsp
C532		nsp	CER. 0.022 μ F 50V Z	nsp
C701		nsp	CER. 680pF 50V K	nsp
C702		nsp	CER. 680pF 50V K	nsp
▲ C703		4822 124 41334	ELECT 470 μ F 35V	EA47703510
▲ C704		4822 124 41334	ELECT 470 μ F 35V	EA47703510
▲ C705		9965 000 01264	ELECT 2200 μ F 25V	EA22802510
C706		nsp	CER. 0.01 μ F 50V Z	nsp
C707		nsp	ELECT 330 μ F 25V	nsp
C708		nsp	CER. 0.01 μ F 50V Z	nsp
C709		nsp	ELECT 100 μ F 16V	nsp
C711		nsp	ELECT 47 μ F 50V	nsp
C712		nsp	CER. 680pF 50V K	nsp
C713		nsp	CER. 680pF 50V K	nsp
C714		nsp	ELECT 47 μ F 50V	nsp
C715		nsp	ELECT 47 μ F 50V	nsp
C716		nsp	ELECT 3.3 μ F 50V	nsp
C720		nsp	CER. 0.022 μ F 50V Z	nsp
C801		nsp	CER. 390pF 50V K	nsp
C802		nsp	CER. 0.01 μ F 50V Z	nsp
C803		nsp	ELECT 100 μ F 16V	nsp
C804		nsp	CER. 33pF 50V J	nsp
C805		nsp	CER. 39pF 50V J	nsp
C806		nsp	ELECT 10 μ F 50V	nsp
C807		nsp	CER. 100pF 50V K	nsp
C808		nsp	CER. 0.022 μ F 50V Z	nsp
C809		nsp	CER. 0.022 μ F 50V Z	nsp
C901		nsp	CER. 0.1 μ F 50V Z	nsp
C902		nsp	CER. 0.022 μ F 50V Z	nsp
C903		nsp	ELECT 100 μ F 10V	nsp
C905		nsp	ELECT 1000 μ F 6.3V	nsp
C907		nsp	CER. 18pF 50V J	nsp
C908		nsp	CER. 12pF 50V J	nsp
C909		nsp	ELECT 22 μ F 16V	nsp
C910		nsp	ELECT 10 μ F 16V	nsp
C911		nsp	CER. 22pF 50V J	nsp
C912		nsp	CER. 18pF 50V J	nsp
C921		nsp	CER. 0.022 μ F 50V Z	nsp
			DIODES	
D201		9965 000 01250	1SS131M	*HD201290R
D203		9965 000 01250	1SS131M	*HD201290R
D302		9965 000 01250	1SS131M	*HD201290R
D303		9965 000 01250	1SS131M	*HD201290R
D501		9965 000 01250	1SS131M	*HD201290R
D202		nsp	VARICAP SVC342-L-AA	*HD400160R
D502		9965 000 01250	1SS131M	*HD201290R
D503		9965 000 01250	1SS131M	*HD201290R
▲ D701		4822 130 31878	1N4003	HD200010AR
▲ D702		4822 130 31878	1N4003	HD200010AR
D703		4822 130 11131	ZENER 13V 1/2W	*HD301430R
D704		4822 130 11132	ZENER 6.2V 1/2W	*HD301450R
▲ D711		4822 130 31878	1N4003	HD200010AR
▲ D712		4822 130 31878	1N4003	HD200010AR
D713		9965 000 01260	ZENER 24V UZ24BMT	*HD301700R
▲ D714		4822 130 11132	ZENER 6.2V 1/2W	*HD301450R
D801		9965 000 01250	1SS131M	*HD201290R
D901		9965 000 01250	1SS131M	*HD201290R
D902		4822 130 11608	LED SLR342VCF02	*HI100810R
D903		9965 000 01250	1SS131M	*HD201290R

(VERS.:VERSION, U:U.S.A., F:JAPAN, K:FAR EAST, N:EUROPE)

(VERS.:VERSION, U:U.S.A., F:JAPAN, K:FAR EAST, N:EUROPE)

POS. NO	VERS. COLOR	PART NO. (FOR PCS)	DESCRIPTION	PART NO. (MJI)	POS. NO	VERS. COLOR	PART NO. (FOR PCS)	DESCRIPTION	PART NO. (MJI)
D905		9965 000 01250	1SS131M	*HD201290R	R119		nsp	1k Ω 1/5W J	nsp
D906		9965 000 01250	1SS131M	*HD201290R	R125		nsp	10 Ω 1/5W J	nsp
D907		9965 000 01250	1SS131M	*HD201290R	R201		nsp	1k Ω 1/5W J	nsp
			INTEGRATED CIRCUITS		R202		nsp	100k Ω 1/5W J	nsp
IC11		4822 209 71785	LA1266	HC10222030	R203		nsp	470 Ω 1/5W J	nsp
IC31		4822 209 70261	LA3410	HC10198030	R204		nsp	100k Ω 1/5W J	nsp
IC32		9965 000 01265	KA4558D	*HC105110R	R205		nsp	10k Ω 1/5W J	nsp
IC51		4822 209 30178	LC7218	HC10211032	R206		nsp	22k Ω 1/5W J	nsp
IC81		4822 209 17453	BFU1923F	*HC104810R	R207		nsp	22k Ω 1/5W J	nsp
IC91		4822 209 16159	MICROPROCESSOR ANAM1239T	*HU243WT0R	R208		nsp	82 Ω 1/5W J	nsp
			FUSE		R209		nsp	100k Ω 1/5W J	nsp
F701	nsp		HOLDER FUSE	nsp	R301		nsp	3.9k Ω 1/5W J	nsp
			COILS		R302		nsp	47 Ω 1/5W J	nsp
L102		4822 157 11873	COIL	*LC107220R	R303		nsp	1k Ω 1/5W J	nsp
L201	nsp		COIL 6.8μH K	nsp	R304		nsp	10k Ω 1/5W J	nsp
L202		9965 000 01253	COIL AM ANT3	*TC000360R	R305		nsp	6.8k Ω 1/5W J	nsp
L203		4822 157 11484	COIL AM OSC	*LO000060R	R306		nsp	22k Ω 1/5W J	nsp
L301		4822 157 11487	COIL MPX	*LS000060R	R307		nsp	270 Ω 1/5W J	nsp
L302		4822 157 11487	COIL MPX	*LS000060R	R308		nsp	10k Ω 1/5W J	nsp
L701		9965 000 01235	COIL INDUCTOR	*TC000350R	R309		nsp	10k Ω 1/5W J	nsp
			TRANSISTORS		R310		nsp	3.9k Ω 1/5W J	nsp
Q101		4822 130 63385	KTC31920	*HT300480R	R311		nsp	1k Ω 1/5W J	nsp
Q102		4822 130 63385	KTC31920	*HT300480R	R312		nsp	560 Ω 1/5W J	nsp
Q301		4822 130 62503	DTC114YS	*BA000730R	R313		nsp	220k Ω 1/5W J	nsp
Q303		4822 130 63659	DTC143TS	*BA000700R	R315		nsp	91k Ω 1/5W J	nsp
Q304		4822 130 63659	DTC143TS	*BA000700R	R316		nsp	91k Ω 1/5W J	nsp
Q305		4822 130 63659	DTC143TS	*BA000700R	R317		nsp	150k Ω 1/5W J	nsp
Q306		4822 130 63659	DTC143TS	*BA000700R	R318		nsp	150k Ω 1/5W J	nsp
Q307		4822 130 42682	DTA144ES	BA10010210	R319		nsp	10k Ω 1/5W J	nsp
Q308		4822 130 61187	DTA144TS	BA10009210	R320		nsp	10k Ω 1/5W J	nsp
Q501		4822 130 61189	DTC114TS	BA20017210	R321		nsp	10k Ω 1/5W J	nsp
Q502		4822 130 62787	DTA114YS	*BA000190R	R324		nsp	3.3k Ω 1/5W J	nsp
Q503		4822 130 62787	DTA114YS	*BA000190R	R325		nsp	100k Ω 1/5W J	nsp
Q504		4822 130 61189	DTC114TS	BA20017210	R326		nsp	100k Ω 1/5W J	nsp
Q511		4822 130 42431	2SC1740SR	HT317401L0	R327		nsp	3.3k Ω 1/5W J	nsp
Q512		4822 130 42431	2SC1740SR	HT317401L0	R328		nsp	3.3k Ω 1/5W J	nsp
▲ Q701		4822 130 11135	KSD288Y	*HT400350R	R329		nsp	1.1k Ω 1/5W J	nsp
▲ Q702		9965 000 01254	KTC3227Y	*HT300490R	R330		nsp	1.1k Ω 1/5W J	nsp
▲ Q703		4822 130 11136	KTA1274Y	*HT100320R	R331		nsp	100 Ω 1/5W J	nsp
Q704		4822 130 42594	DTC144ES	BA20012210	R332		nsp	100 Ω 1/5W J	nsp
Q901		4822 130 62503	DTC114YS	*BA000730R	R333		nsp	100k Ω 1/5W J	nsp
Q902		4822 130 62787	DTA114YS	*BA000190R	R334		nsp	100k Ω 1/5W J	nsp
Q903		4822 130 62503	DTC114YS	*BA000730R	R335		nsp	100 Ω 1/5W J	nsp
Q905		4822 130 62787	DTA114YS	*BA000190R	R336		nsp	100 Ω 1/5W J	nsp
Q906		4822 130 60107	2SA933SR	HT109331S0	R501		nsp	1k Ω 1/5W J	nsp
Q907		4822 130 62503	DTC114YS	*BA000730R	R502		nsp	10k Ω 1/5W J	nsp
Q908		4822 130 62787	DTA114YS	*BA000190R	R505		nsp	10k Ω 1/5W J	nsp
			RESISTORS		R508		nsp	10k Ω 1/5W J	nsp
R103	nsp		47 Ω 1/5W J	nsp	R510		nsp	1k Ω 1/5W J	nsp
R104	nsp		390 Ω 1/5W J	nsp	R511		nsp	560 Ω 1/5W J	nsp
R105	nsp		1.2k Ω 1/5W J	nsp	R512		nsp	5.6k Ω 1/5W J	nsp
R106	nsp		820k Ω 1/5W J	nsp	R513		nsp	10k Ω 1/5W J	nsp
R107	nsp		560 Ω 1/5W J	nsp	R520		nsp	10k Ω 1/5W J	nsp
R108	nsp		470k Ω 1/5W J	nsp	}		nsp	10k Ω 1/5W J	nsp
R109	nsp		270 Ω 1/5W J	nsp	R524		nsp	10k Ω 1/5W J	nsp
R110	nsp		1.8k Ω 1/5W J	nsp	R525		nsp	470k Ω 1/5W J	nsp
R111	nsp		1.5k Ω 1/5W J	nsp	R527		nsp	10k Ω 1/5W J	nsp
R112	nsp		5.6k Ω 1/5W J	nsp	R531		nsp	470k Ω 1/5W J	nsp
R115	nsp		15k Ω 1/5W J	nsp	R532		nsp	470k Ω 1/5W J	nsp
R116	nsp		2.7k Ω 1/5W J	nsp	R533		nsp	10k Ω 1/5W J	nsp
R117	nsp		15k Ω 1/5W J	nsp	R601		nsp	10k Ω 1/5W J	nsp
R118	nsp		2.7k Ω 1/5W J	nsp	R602		nsp	10k Ω 1/5W J	nsp
					▲ R701	9965 000 01262		27 Ω 1/2W J FUSE	*NH000100R
					R702		nsp	1k Ω 1/5W J	nsp
					R703		nsp	100 Ω 1/5W J	nsp
					R704		nsp	1k Ω 1/5W J	nsp
					R705		nsp	100 Ω 1/5W J	nsp

(VERS.:VERSION, U:U.S.A., F:JAPAN, K:FAR EAST, N:EUROPE)

(VERS.:VERSION, U:U.S.A., F:JAPAN, K:FAR EAST, N:EUROPE)

POS. NO	VERS. COLOR	PART NO. (FOR PCS)	DESCRIPTION	PART NO. (MJI)	POS. NO	VERS. COLOR	PART NO. (FOR PCS)	DESCRIPTION	PART NO. (MJI)
R707		nsp	47k Ω 1/5W J	nsp					
R708		nsp	18k Ω 1/5W J	nsp					
R709		nsp	4.7k Ω 1/5W J	nsp					
R711		nsp	330 Ω 1/5W J	nsp					
R712		nsp	47k Ω 1/5W J	nsp					
R713		nsp	4.7 Ω 1/5W J	nsp					
R714		nsp	47k Ω 1/5W J	nsp					
R715		nsp	3.3 Ω 1/5W J	nsp					
R716		nsp	3.3 Ω 1/5W J	nsp					
R801		nsp	10 Ω 1/5W J	nsp					
R802		nsp	470 Ω 1/5W J	nsp					
R805		nsp	1k Ω 1/5W J	nsp					
R806		nsp	1k Ω 1/5W J	nsp					
R901		nsp	1k Ω 1/5W J	nsp					
R902		nsp	470 Ω 1/5W J	nsp					
R903		nsp	100k Ω 1/5W J	nsp					
R905		nsp	1k Ω 1/5W J	nsp					
R906		nsp	22k Ω 1/5W J	nsp					
R907		nsp	47k Ω 1/5W J	nsp					
R908		nsp	47k Ω 1/5W J	nsp					
R909		nsp	47k Ω 1/5W J	nsp					
R910		nsp	100k Ω 1/5W J	nsp					
R911		nsp	10k Ω 1/5W J	nsp					
R912		nsp	47k Ω 1/5W J	nsp					
R913		nsp	47k Ω 1/5W J	nsp					
R915									
∫		nsp	47k Ω 1/5W J	nsp					
R924									
R951		nsp	3.3 Ω 1/5W J	nsp					
			SWITCHES						
S601		4822 276 14107	SW. TACT	*SP000880R					
S911		9965 000 01263	SW. TACT	*SP000890R					
S913									
∫		9965 000 01263	SW. TACT	*SP000890R					
S926									
			MISCELLANEOUS						
CN71		nsp	7.92MM(YUNHO)	nsp					
CN72		nsp	MOLEX 5267-07A	nsp					
CN91		nsp	MOLEX53014-0610	nsp					
CN92		nsp	WAFER	nsp					
BN72		nsp	WIRE ASSY	nsp					
BN91		nsp	WIRE ASSY	nsp					
BN92		nsp	WIRE ASSY	nsp					
BN95		nsp	WIRE ASSY	nsp					
FIP1		9965 000 01234	FLD SVA-14MM11	*HQ300380R					
FP11		4822 210 10802	TUNER PACK FTA4460H	*AV000060R					
JK11		4822 265 11601	TERMINAL ANT.SC0210392N	*YT001500R					
JK31		4822 265 11205	RCA JACK 2P KC S436P	*YT001170R					
JK32		4822 265 11206	RCA JACK 2P ORANGE	*YT001180R					
JW91		nsp	WIRE ASSY	nsp					
T101		4822 157 11861	IFT FM	*LA000110R					
T102		4822 157 11489	IFT FM	*LI000070R					
T201		9965 000 01267	IFT AM	*TC000370R					
T701		4822 146 10926	TRANS MAINS 230V	*TS000780R					
VR21		4822 101 11853	RES.TRIM EVNDJAA03B24	*RA000790R					
VR31		9965 000 01270	RES.TRIM EVNDJAA03B15	*RA000930R					
VR11		9965 000 01271	RES.TRIM EVNDJAA03B54	*RA000940R					
X201		4822 242 82242	CER. FIL. BFU450C4N	*FF100190R					
X301		4822 242 81117	RESONATOR CSB456F11	FQ04563010					
X501		4822 242 72333	CRYSTAL 7.2MHz	JX07001261					
X801		4822 242 11042	CRYSTAL 4.332MHz	*JX000540R					
X901		4822 242 10855	CRYSTAL 8MHz	*JX000410R					
X902		4822 242 72236	CRYSTAL 32 768kHz DT-38	XO001001T2					