

Service Manual

ST6000/N1B, /N1G
/U1B, /F1N

Tuner

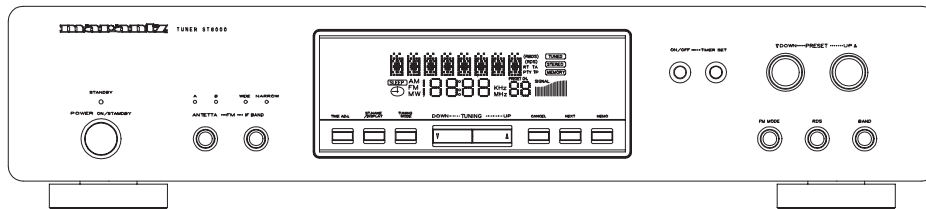

TABLE OF CONTENTS

1.	TECHNICAL SPECIFICATIONS	1
2.	WIRING DIAGRAM	2
3.	BLOCK DIAGRAM	3
4.	SCHEMATIC DIAGRAM AND PARTS LOCATION	7
5.	MICROPROCESSOR AND IC DATA	19
6.	ADJUSTMENT PROCEDURE	21
7.	EXPLODED VIEW AND PARTS LIST	23
8.	ELECTRICAL PARTS LIST	26

Please use this service manual with referring to the user guide (D.F.U) without fail.

修理の際は、必ず取扱説明書を準備し操作方法を確認の上作業を行って下さい。

marantz®

- ST6000 -

MARANTZ DESIGN AND SERVICE

Using superior design and selected high grade components, **MARANTZ** company has created the ultimate in stereo sound. Only original **MARANTZ** parts can insure that your **MARANTZ** product will continue to perform to the specifications for which it is famous.

Parts for your **MARANTZ** equipment are generally available to our National Marantz Subsidiary or Agent.

ORDERING PARTS :

Parts can be ordered either by mail or by Fax.. In both cases, the correct part number has to be specified.

The following information must be supplied to eliminate delays in processing your order :

1. Complete address
2. Complete part numbers and quantities required
3. Description of parts
4. Model number for which part is required
5. Way of shipment
6. Signature : any order form or Fax. must be signed, otherwise such part order will be considered as null and void.

USA

MARANTZ AMERICA, INC.
440 MEDINAH ROAD
ROSELLE, ILLINOIS 60172
USA
PHONE : 630 - 307 - 3100
FAX : 630 - 307 - 2687

EUROPE / TRADING

MARANTZ EUROPE B.V.
P.O.BOX 80002, BUILDING SFF2
5600 JB EINDHOVEN
THE NETHERLANDS
PHONE : +31 - 40 - 2732241
FAX : +31 - 40 - 2735578

BRAZIL

MARANTZ BRAZIL
CAIXA POSTAL 21462
CEP 04698-970
SAO PAULO, SP, BRAZIL
PHONE : 0800 - 123123(Discagem Direta Gratuita)
FAX : +55 11 534. 8988

PROFESSIONAL AMERICAS

SUPERSCOPE TECHNOLOGIES, INC.
MARANTZ PROFESSIONAL PRODUCTS
2640 WHITE OAK CIRCLE, SUITE A
AURORA, ILLINOIS 60504 USA
PHONE : 630 - 820 - 4800
FAX : 630 - 820 - 8103

CANADA

LENBROOK INDUSTRIES LIMITED
633 GRANITE COURT,
PICKERING, ONTARIO L1W 3K1
CANADA
PHONE : 905 - 831 - 6333
FAX : 905 - 831 - 6936

AUSTRALIA

JAMO AUSTRALIA PTY LTD
1 EXPO COURT, P.O. BOX 350
MT. WAVERLEY VIC 3149
AUSTRALIA
PHONE : +61 - 3 - 9543 - 1522
FAX : +61 - 3 - 9543 - 3677

THAILAND

MRZ STANDARD CO.,LTD
746 - 754 MAHACHAI ROAD.,
WANGBURAPAPIROM, PHRANAKORN,
BANGKOK, 10200 THAILAND
PHONE : +66 - 2 - 222 9181
FAX : +66 - 2 - 224 6795

SINGAPORE

WO KEE HONG (S) PTE LTD
WO KEE HONG CENTRE
NO.23, LORONG 8, TOA PAYOH
SINGAPORE 319257
PHONE : +65 2544555
FAX : +65 2502213

TAIWAN

PAI- YUING CO., LTD.
6 TH FL NO, 148 SUNG KIANG ROAD,
TAIPEI, 10429, TAIWAN R.O.C.
PHONE : +886 - 2 - 25221304
FAX : +886 - 2 - 25630415

MALAYSIA

WO KEE HONG ELECTRONICS SDN. BHD.
NO. 102 JALAN SS 21/35, DAMANSARA
UTAMA, 47400 PETALING JAYA
SELANGOR DARUL EHSAN, MALAYSIA
PHONE : +60 3 - 7184666
FAX : +60 3 - 7173828

JAPAN *Technical*

MARANTZ JAPAN, INC.
35- 1, 7- CHOME, SAGAMIONO
SAGAMIHARA - SHI, KANAGAWA
JAPAN 228-8505
PHONE : +81 42 748 1013
FAX : +81 42 748 9190

日本マランツ株式会社

本社 〒228-8505
神奈川県相模原市相模大野7-35-1
営業本部 〒150-0022
東京都渋谷区恵比寿南1-11-9

KOREA

MK ENTERPRISES LTD.
ROOM 604/605, ELECTRO-OFFICETEL, 16-58,
3GA, HANGANG-RO, YONGSAN-KU, SEOUL
KOREA
PHONE : +822 - 3232 - 155
FAX : +822 - 3232 - 154

SHOCK, FIRE HAZARD SERVICE TEST :

CAUTION : After servicing this appliance and prior to returning to customer, measure the resistance between either primary AC cord connector pins (with unit NOT connected to AC mains and its Power switch ON), and the face or Front Panel of product and controls and chassis bottom.

Any resistance measurement less than 1 Megohms should cause unit to be repaired or corrected before AC power is applied, and verified before it is return to the user/customer.

Ref. UL Standard No. 1492.

In case of difficulties, do not hesitate to contact the Technical Department at above mentioned address.

1. TECHNICAL SPECIFICATION

FM Section

Frequency Range 87.50MHz-108.00MHz(50kHz steps)
 87.50MHz-108.00MHz(50kHz steps)
 76.00MHz-90.00MHz(50kHz steps)
 Usable Sensitivity (IHF) Mono : 10dBf
 Frequency Response 20Hz~15kHz
 +0.5 ~ -3.0dB
 T.H.D (at 65dBf, 1kHz) Mono : 0.1%
 Stereo : 0.2%
 Signal-to-Noise Ratio (at 65dBf, 1kHz) Mono : 70dB
 Stereo : 65dB
 AM Suppression Ratio 60dB
 Stereo Separation (1kHz) 40dB

General

Power Requirements AC 230V ,50Hz (/N1)
 AC 120V ,60Hz (/U1)
 AC 100V ,50Hz/60Hz (/F1)
 Power Consumption 8W
 Dimensions (WxHxD) 440x96x311mm
 Weight (net) 3.8Kg

MW Section

Frequency Range 522kHz-1622kHz (9kHz step)
 520kHz-1710kHz (10kHz step)
 Usable Sensitivity (S/N 20dB) 55dBm
 Image Response Ratio 35dB
 T.H.D (400Hz) 0.8%
 Signal-to-Noise Ratio 40dB (at 85dB/m)

LW Section (/N1 only)

Frequency Range 146kHz-290kHz (1kHz step)
 Usable Sensitivity (S/N 20dB) 60dBm
 T.H.D (400Hz) 1.0%
 Signal-to-Noise Ratio 40dB (at 85dB/m)

Standard Accessories

Audio signal connection cord 1
 Remote control connection cord 1
 FM Antenna 1
 AM Loop Antenna 1
 User Guide 1
 Remocon Unit (/U1 , /F1) (RC6000ST) 1
 75-300ohm adaptor (/U1 , /F1) 1

2.WIRING DIAGRAM

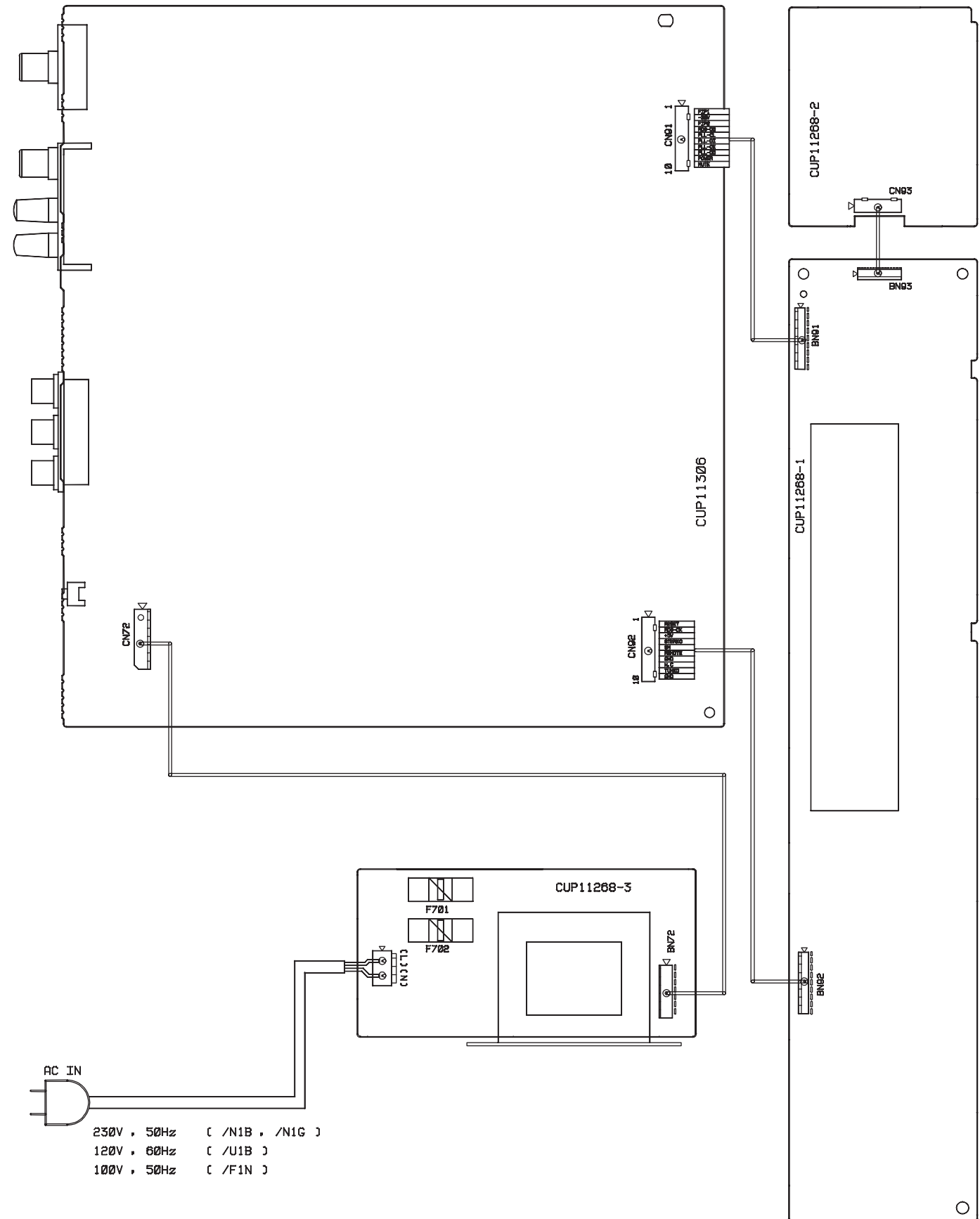

3. BLOCK DIAGRAM (/N1B,/N1G) VERSION

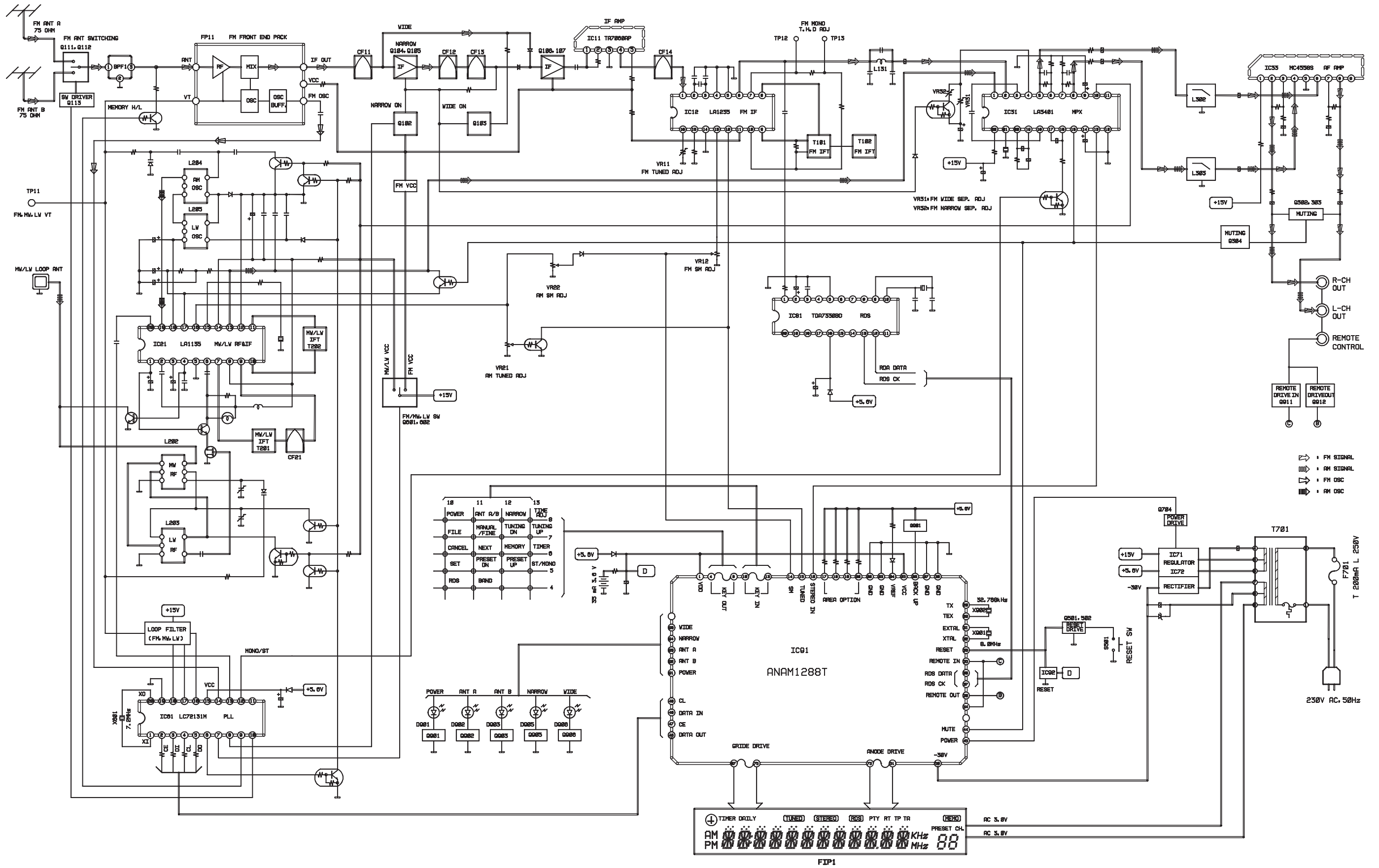

(/U1B,/F1N) VERSION

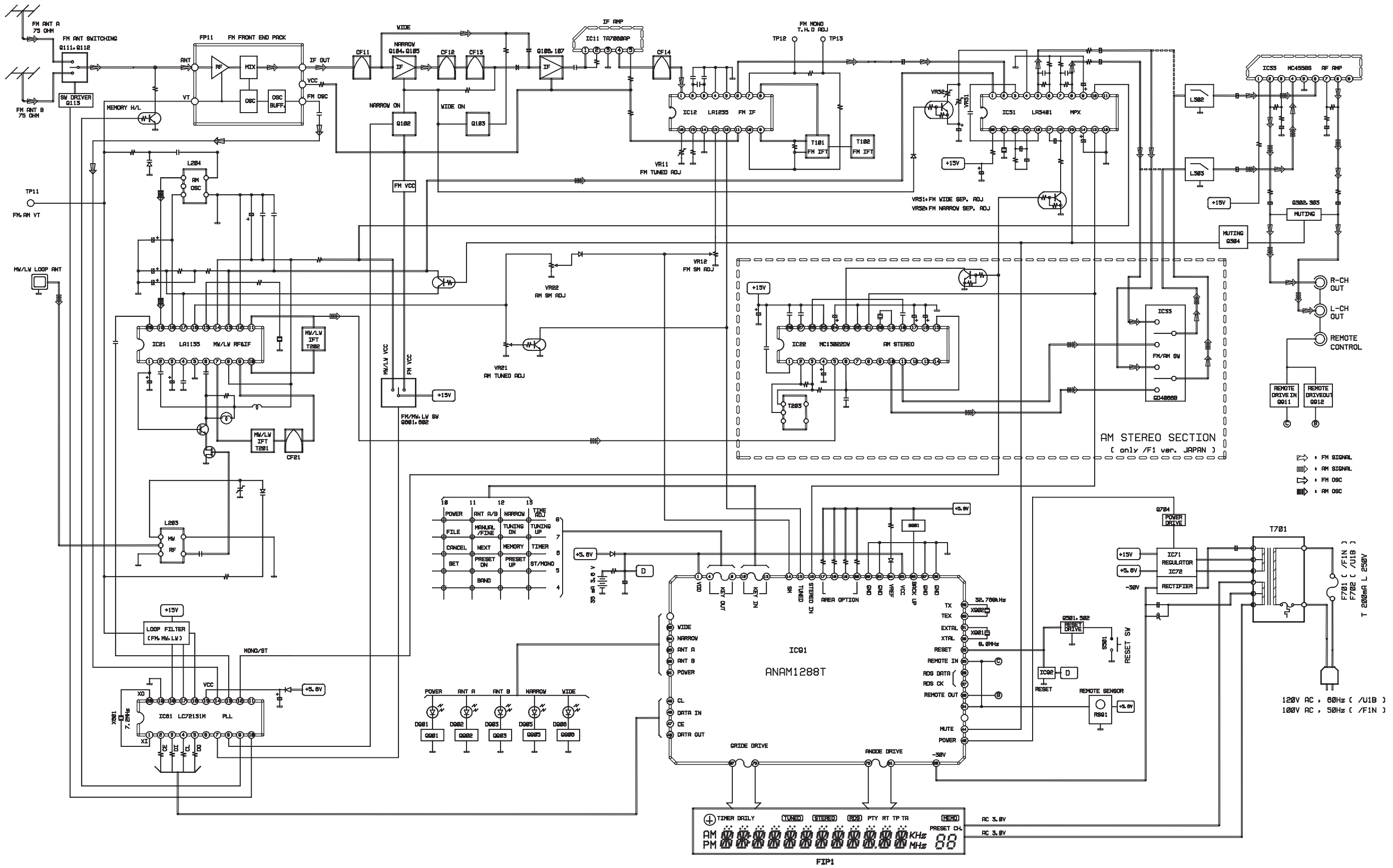

4. SCHEMATIC DIAGRAM AND PARTS LOCATION (N1B,N1G) VERSION

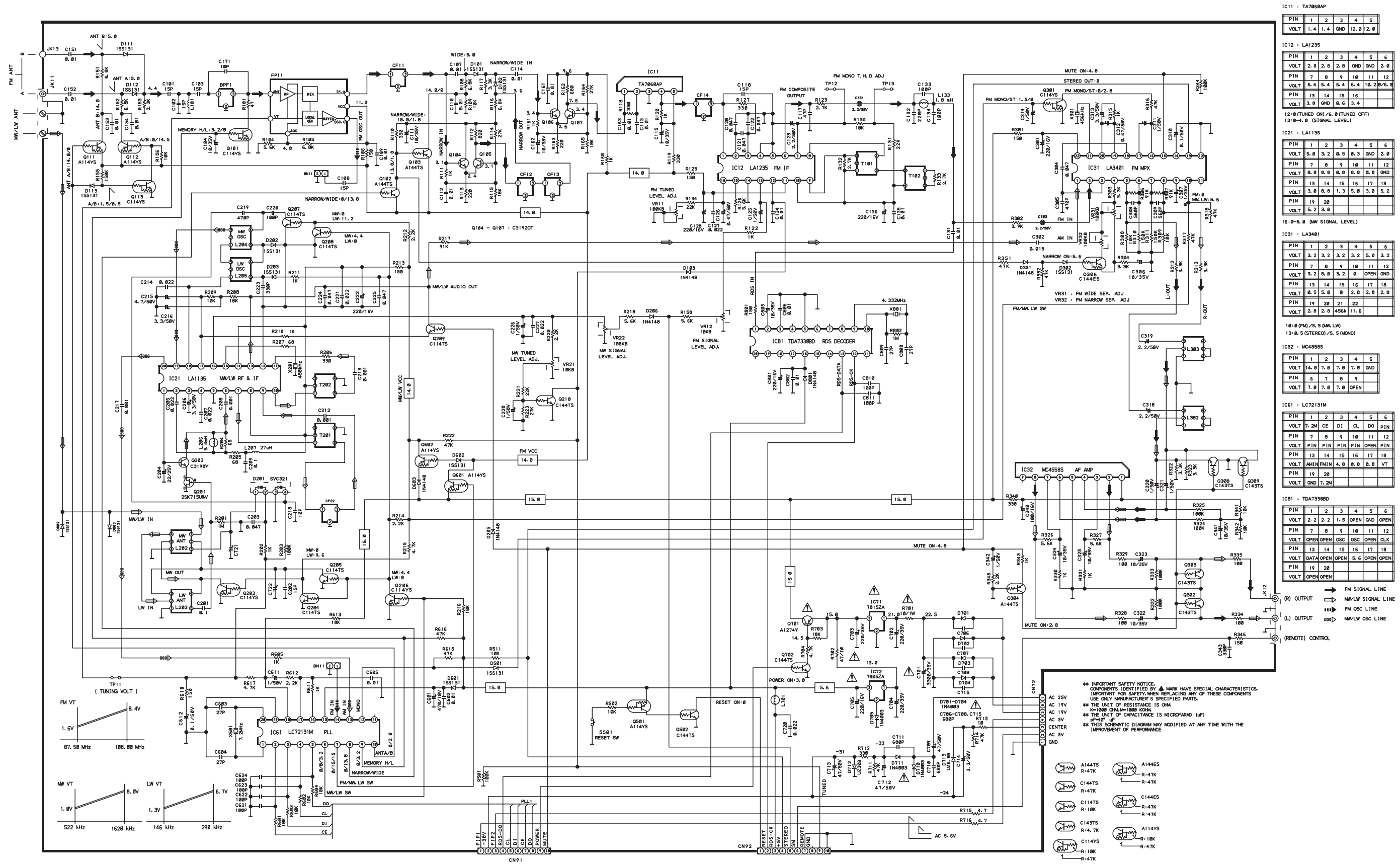

IC11 : TA7868AP

PIN	1	2	3	4	5
VOLT	1.4	1.4	GND	12.0	12.0

IC12 : LA1235

PIN	1	2	3	4	5	6
VOLT	2.0	2.0	2.0	GND	GND	2.0
PIN	7	8	9	10	11	12
VOLT	6.4	6.4	6.4	6.4	10.2	6.4
PIN	13	14	15	16		
VOLT	3.0	GND	0.6	3.4		

IC21 : LA1135

PIN	1	2	3	4	5	6
VOLT	5.0	3.2	0.5	0.3	GND	2.0
PIN	7	8	9	10	11	12
VOLT	0.5	0.8	0.8	0.8	0.8	GND
PIN	13	14	15	16	17	18
VOLT	3.0	0.0	1.3	5.0	3.0	5.2
PIN	19	20				
VOLT	5.2	3.0				

IC31 : LA3481

PIN	1	2	3	4	5	6
VOLT	3.2	3.2	3.2	3.2	5.0	3.2
PIN	7	8	9	10	11	12
VOLT	3.2	5.0	3.2	0.0	OPEN	GND
PIN	13	14	15	16	17	18
VOLT	0.5	5.0	0.0	2.0	2.0	2.0
PIN	19	20	21	22		
VOLT	2.0	2.0	0.0	4.56k	11.6	

IC32 : MC45585

PIN	1	2	3	4	5
VOLT	14.0	7.0	7.0	7.0	GND
PIN	6	7	8	9	
VOLT	7.0	7.0	7.0	OPEN	

IC61 : LC72131M

PIN	1	2	3	4	5	6
VOLT	7.2M	CE	DI	CL	DO	PIN
PIN	7	8	9	10	11	12
VOLT	PIN	PIN	PIN	PIN	OPEN	PIN
PIN	13	14	15	16	17	18
VOLT	AMIN	FMIN	4.0	0.8	0.8	VT
PIN	19	20				
VOLT	PIN	GND	7.2M			

IC81 : TDA7388D

PIN	1	2	3	4	5	6
VOLT	2.2	2.2	1.5	OPEN	GND	OPEN
PIN	7	8	9	10	11	12
VOLT	OPEN	OPEN	OSC	OSC	OPEN	CLK
PIN	13	14	15	16	17	18
VOLT	DATA	OPEN	OPEN	5.6	OPEN	OPEN
PIN	19	20				
VOLT	OPEN	OPEN				

(R) OUTPUT → FM SIGNAL LINE
 (L) OUTPUT → MW/LW SIGNAL LINE
 (M) → FM OSC LINE
 (N) → MW/LW OSC LINE
 (O) → (REMOTE) CONTROL

**** IMPORTANT SAFETY NOTICE.**
 COMPONENTS IDENTIFIED BY MARK HAVE SPECIAL CHARACTERISTICS.
 IMPORTANT FOR SAFETY, WHEN REPLACING ANY OF THESE COMPONENTS
 USE ONLY MANUFACTURER'S SPECIFIED PARTS.
 ** THE UNIT OF RESISTANCE IS OHM.
 ** K=1000 OHM, M=1000 KOHM.
 ** THE UNIT OF CAPACITANCE IS MICROFARAD (UF).
 ** THIS SCHEMATIC DIAGRAM MAY MODIFIED AT ANY TIME WITH THE
 IMPROVEMENT OF PERFORMANCE.

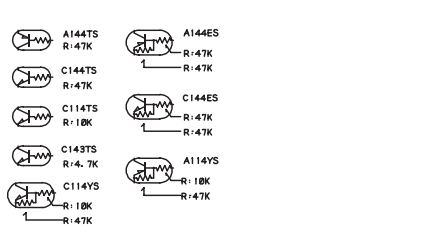

(/U1B) VERSION

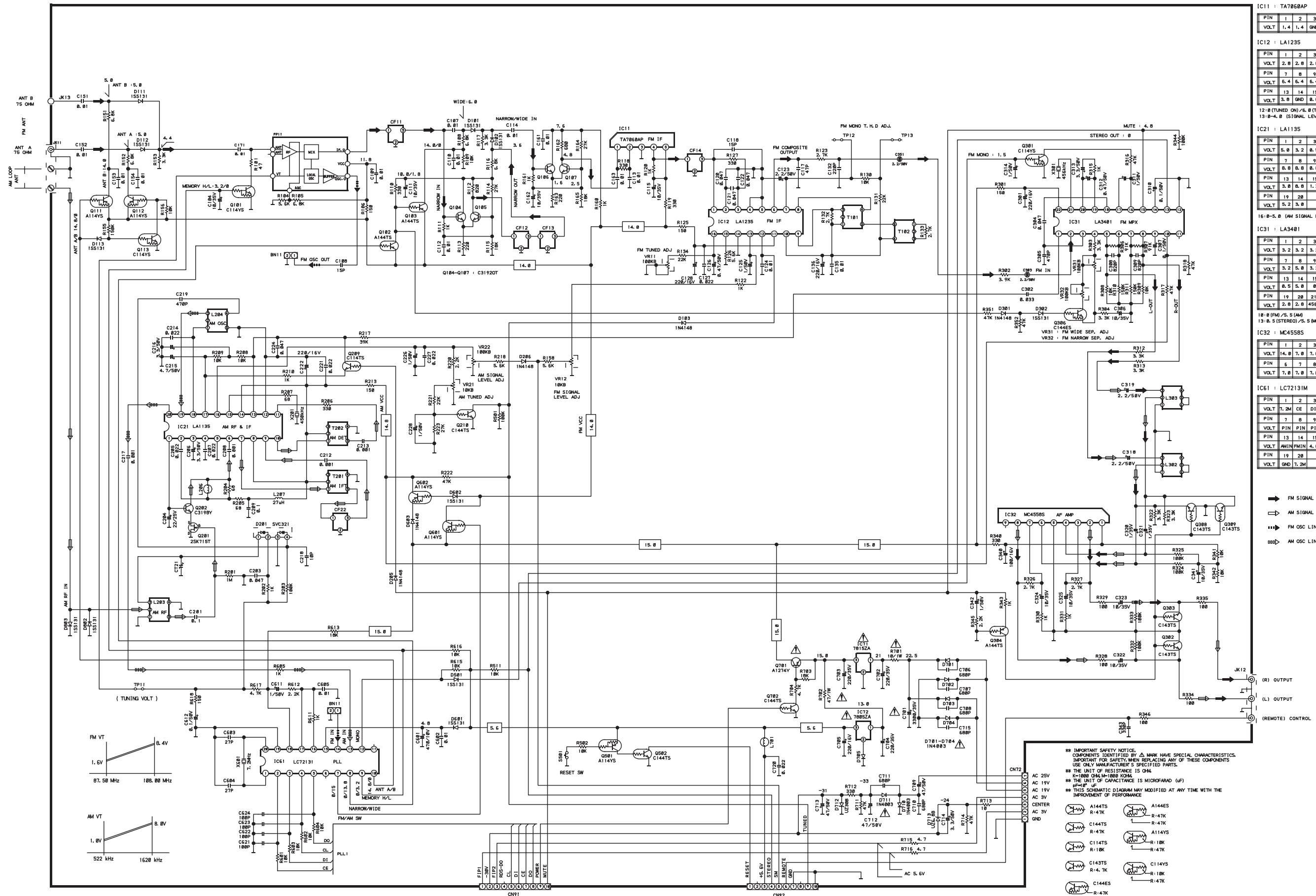

IC11 : TA7858AP

PIN	1	2	3	4	5
VOLT	1.4	1.4	GND	12.8	12.8

IC12 : LA1235

PIN	1	2	3	4	5	6
VOLT	2.8	2.8	2.8	GND	GND	2.8
PIN	7	8	9	10	11	12
VOLT	6.4	6.4	6.4	6.4	10.2	10.2
PIN	13	14	15	16	17	18
VOLT	3.8	GND	8.6	3.4		

12:8 (TUNED ON)/5.8 (TUNED OFF)
13:8-4.8 (SIGNAL LEVEL)

IC21 : LA1195

PIN	1	2	3	4	5	6
VOLT	5.0	3.2	3.2	3.2	5.0	3.2
PIN	7	8	9	10	11	12
VOLT	8.8	8.8	8.8	8.8	GND	GND
PIN	13	14	15	16	17	18
VOLT	8.8	8.8	1.3	5.8	3.8	5.2
PIN	19	20				
VOLT	2.8	3.8				

16:8-5.8 (AM SIGNAL LEVEL)

IC31 : LA3401

PIN	1	2	3	4	5	6
VOLT	3.2	3.2	3.2	3.2	5.0	3.2
PIN	7	8	9	10	11	12
VOLT	3.2	5.0	3.2	0	OPEN	GND
PIN	13	14	15	16	17	18
VOLT	8.5	5.0	0	2.8	2.8	2.8
PIN	19	20	21	22		
VOLT	2.8	2.8	45E4	11.6		

18:8 (FM)/5.5 (AM)
19:8.5 (STEREO)/5.5 (MONO)

IC32 : MC45585

PIN	1	2	3	4	5
VOLT	14.8	7.0	7.0	7.0	GND
PIN	6	7	8	9	
VOLT	7.0	7.0	7.0	OPEN	

IC61 : LC72131M

PIN	1	2	3	4	5	6
VOLT	7.2M	CE	DI	CL	DO	PIN
PIN	7	8	9	10	11	12
VOLT	PIN	PIN	PIN	PIN	OPEN	PIN
PIN	13	14	15	16	17	18
VOLT	AMIN	FMIN	4.8	0.8	0.8	VT
PIN	19	20				
VOLT	GND	7.2M				

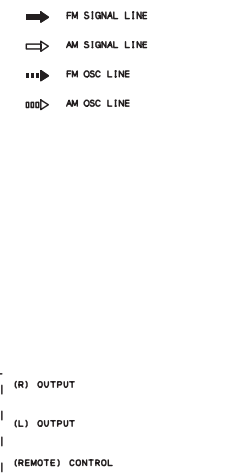

IMPORTANT SAFETY NOTICE:
COMPONENTS IDENTIFIED BY A MARK HAVE SPECIAL CHARACTERISTICS. USE ONLY MANUFACTURER'S SPECIFIED PARTS.
* THE UNIT OF RESISTANCE IS OHM.
* K=1000 OHM, M=1000 K OHM.
* THE UNIT OF CAPACITANCE IS MICROFARAD (UF).
* THIS SCHEMATIC DIAGRAM MAY MODIFIED AT ANY TIME WITH THE IMPROVEMENT OF PERFORMANCE.

Component list:

- A144TS R-47K
- A144ES R-47K
- C144TS R-47K
- A114YS R-18K
- C114TS R-18K
- C143TS R-18K
- C143TS R-4.7K
- C144ES R-18K
- R-47K

(F1N) VERSION

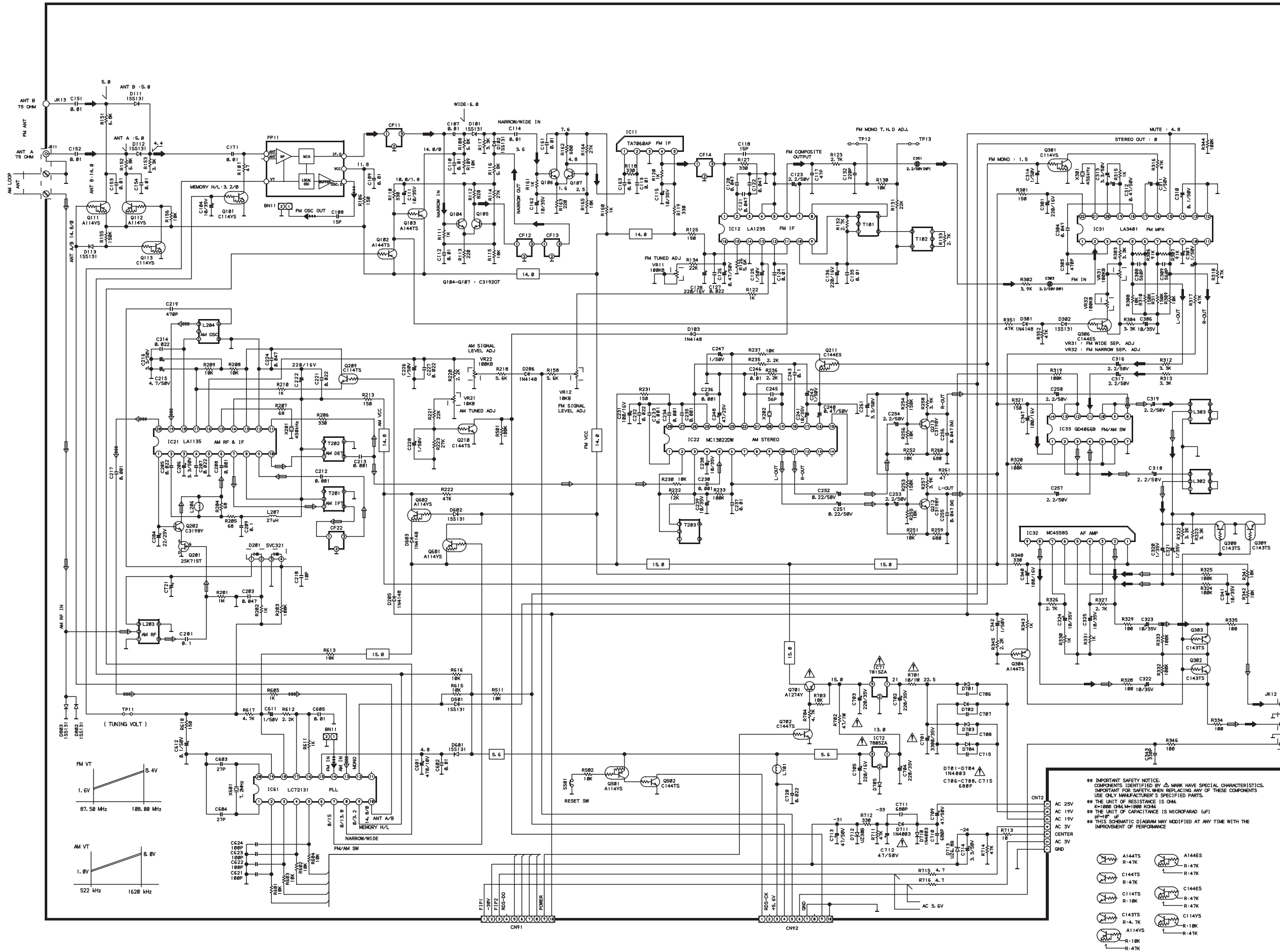

IC11 : TA7668AP

PIN	1	2	3	4	5
VOLT	1.4	1.4	GND	12.0	12.0

IC12 : LA1235

PIN	1	2	3	4	5	6
VOLT	2.0	2.0	2.0	GND	GND	2.0
PIN	7	8	9	10	11	12
VOLT	6.4	6.4	6.4	6.4	10.2	6.4
PIN	13	14	15	16		
VOLT	3.0	GND	8.6	3.4		

IC21 : LA1135

PIN	1	2	3	4	5	6
VOLT	5.0	3.2	8.5	3.0	GND	2.0
PIN	7	8	9	10	11	12
VOLT	8.0	8.0	8.0	8.0	8.0	GND
PIN	13	14	15	16	17	18
VOLT	3.0	8.0	1.3	5.0	3.0	5.2
PIN	19	20				
VOLT	5.2	3.0				

IC22 : MC13022DW

PIN	1	2	3	4	5	6
VOLT	8.0	3.0	3.0	1.7	1.1	2.9
PIN	7	8	9	10	11	12
VOLT	OPEN	OPEN	OPEN	1.1	1.1	OPEN
PIN	13	14	15	16	17	18
VOLT	OPEN	OPEN	2.9	2.5	2.3	3.0
PIN	19	20	21	22	23	24
VOLT	OSC	OSC	5.0	GND	3.5	3.0
PIN	25	26	27	28		
VOLT	8.6	3.0	8.0	8.2		

IC31 : LA3401

PIN	1	2	3	4	5	6
VOLT	3.2	3.2	3.2	3.2	5.0	3.2
PIN	7	8	9	10	11	12
VOLT	3.2	5.0	3.2	0	OPEN	GND
PIN	13	14	15	16	17	18
VOLT	8.5	5.0	0	2.0	2.0	2.0
PIN	19	20	21	22		
VOLT	2.0	2.0	4.56A	11.6		

IC32 : MC45585

PIN	1	2	3	4	5
VOLT	14.0	7.0	7.0	7.0	GND
PIN	6	7	8	9	
VOLT	7.0	7.0	7.0	OPEN	

IC61 : LC72131M

PIN	1	2	3	4	5	6
VOLT	7.2M	CE	D1	CL	DO	PIN
PIN	7	8	9	10	11	12
VOLT	PIN	PIN	PIN	PIN	OPEN	PIN
PIN	13	14	15	16	17	18
VOLT	AM IN	FM IN	4.0	8.0	8.0	VT
PIN	19	20				
VOLT	GND	7.2M				

IC81 : TDA7330BD

PIN	1	2	3	4	5	6
VOLT	2.2	2.2	1.5	OPEN	GND	OPEN
PIN	7	8	9	10	11	12
VOLT	OPEN	OPEN	OSC	OSC	OPEN	CLK
PIN	13	14	15	16	17	18
VOLT	DATA	OPEN	OPEN	5.6	OPEN	OPEN
PIN	19	20				
VOLT	OPEN	OPEN				

(R) OUTPUT → FM SIGNAL LINE
 (L) OUTPUT → AM SIGNAL LINE
 (M) → FM OSC LINE
 (N) → AM OSC LINE
 (REMOTE) CONTROL

IMPORTANT SAFETY NOTICE
 COMPONENTS IDENTIFIED BY Δ MARK HAVE SPECIAL CHARACTERISTICS.
 IMPORTANT FOR SAFETY: WHEN REPLACING ANY OF THESE COMPONENTS
 USE ONLY MANUFACTURER'S SPECIFIED PARTS.
 ** THE UNIT OF CAPACITANCE IS 0.01 μF
 ** THIS SCHEMATIC DIAGRAM MAY MODIFIED AT ANY TIME WITH THE
 IMPROVEMENT OF PERFORMANCE

- A144TS R-47K
- A144ES R-47K
- C144TS R-47K
- C144ES R-47K
- C143TS R-18K
- C143ES R-18K
- A114YS R-18K
- A114ES R-47K

IC71 IC33 Q302 Q303 Q205 Q201 Q208 Q207 IC11 Q111
 IC72 Q306 IC31 IC32 Q213 Q206 Q204 Q203 IC21 Q202 Q209 Q107 Q101 Q113 Q112
 Q701 IC81 Q301 Q212 Q211 Q210 IC22 IC12 Q602 Q106 Q105 Q104
 Q502 Q501 Q702 Q601 Q102 Q103 IC61

CUP 11306

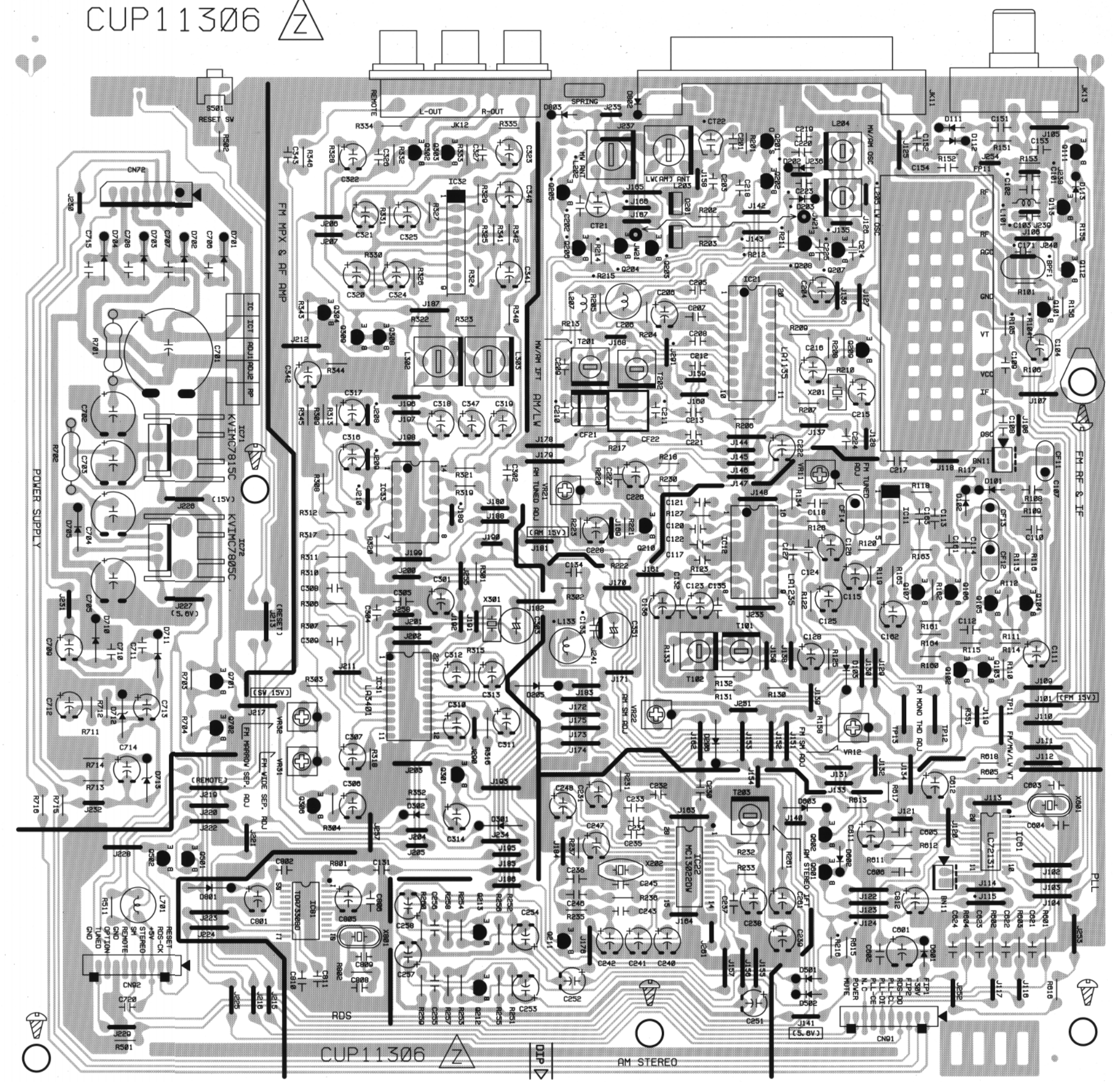

IC32 : MC4558S

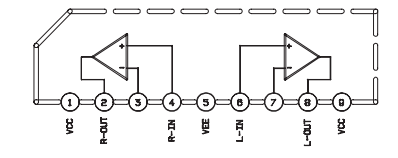

IC21 : LA1135

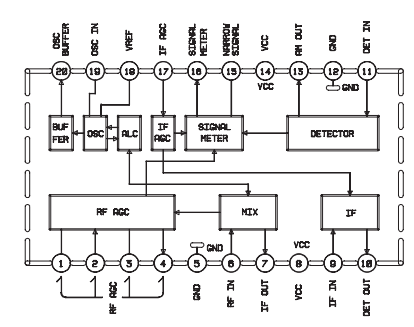

IC12 : LA1235

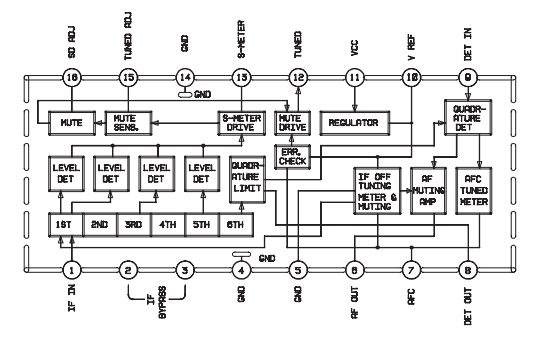

CUP11306 AM STEREO

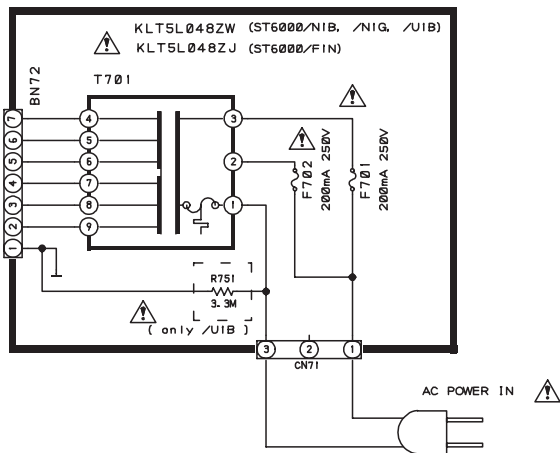
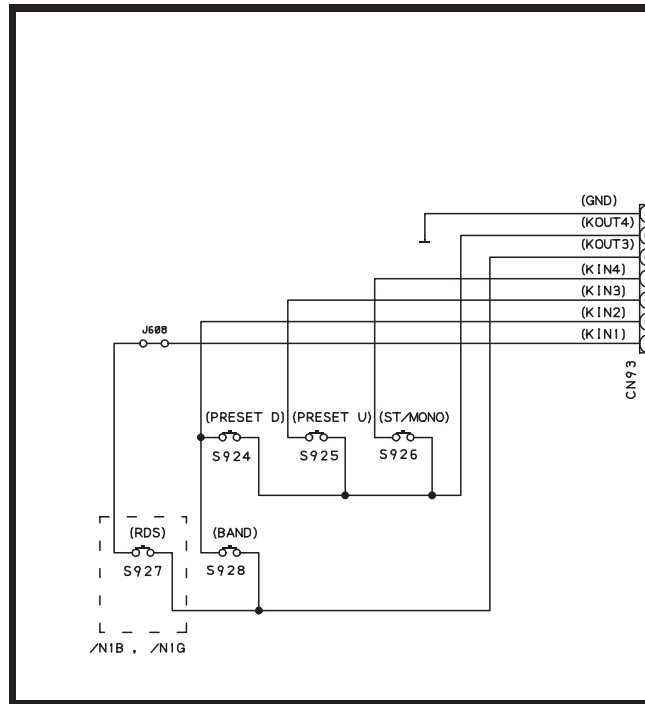

MODEL	AREA	AC POWER IN	F701	F702	SW71	R751
ST6000/N1B	Europe	AC 230V, 50Hz	O	X	X	X
ST6000/N1G	USA	AC 120V, 60Hz	X	O	X	O
ST6000/U1B	CANADA	AC 120V, 60Hz	X	O	X	O
ST6000/FIN	JAPAN	AC 100V, 50Hz	X	O	X	X

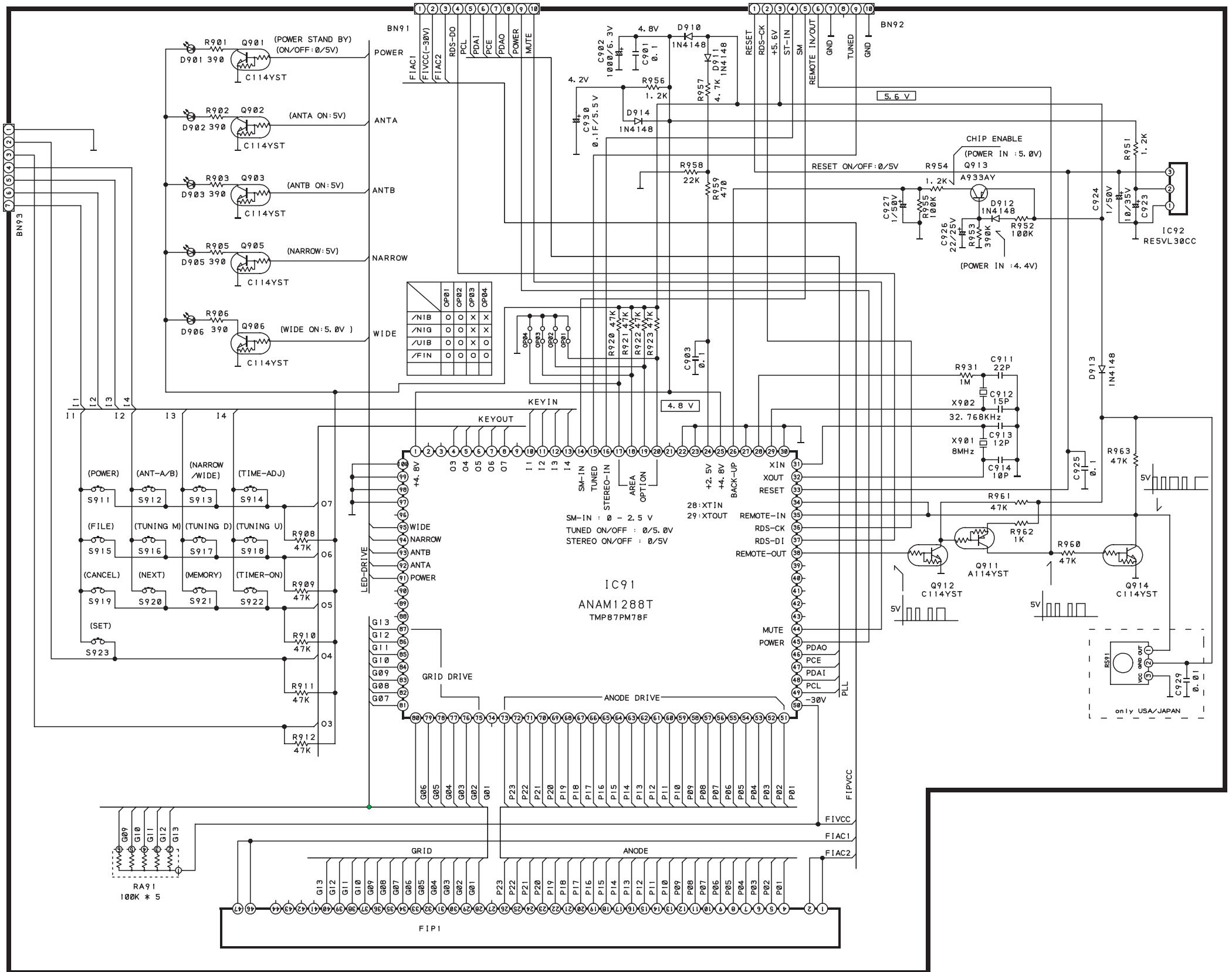

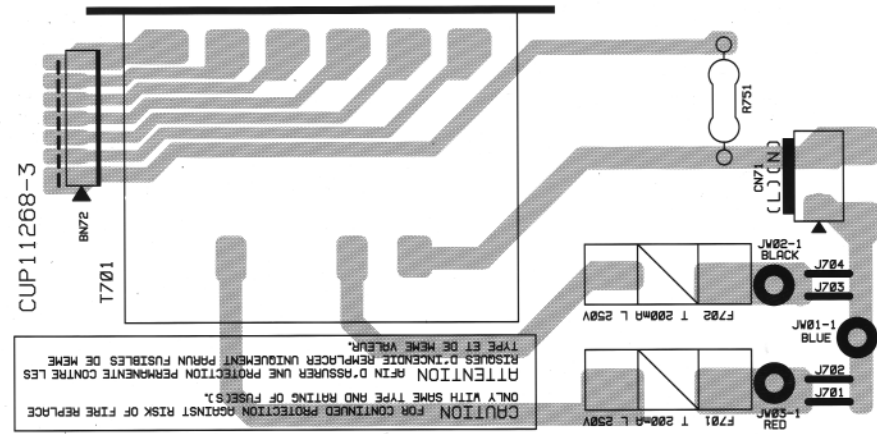

CAUTION FOR CONTINUED PROTECTION AGAINST RISK OF FIRE REPLACE ONLY WITH SAME TYPE AND RATING OF FUSES.
ATTENTION REIN ASSURER UNE PROTECTION PERMANENTE CONTRE LES RISQUES D'INCENDIE REMPLACER UNIQUEMENT PAR UN FUSIBLE DE MEME TYPE ET DE MEME VALEUR.

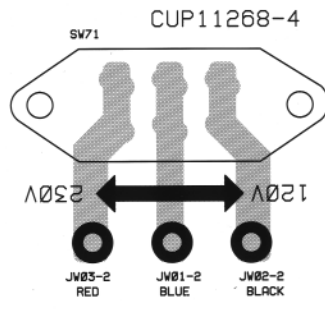

IC	ICT	ADJ1	ADJ2	RP

CUP11268



J201
J202
J203
J204
J205

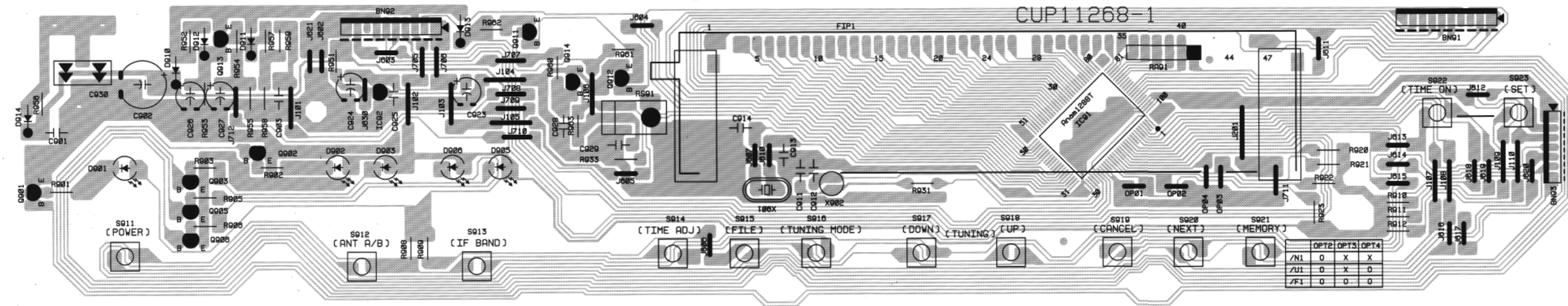
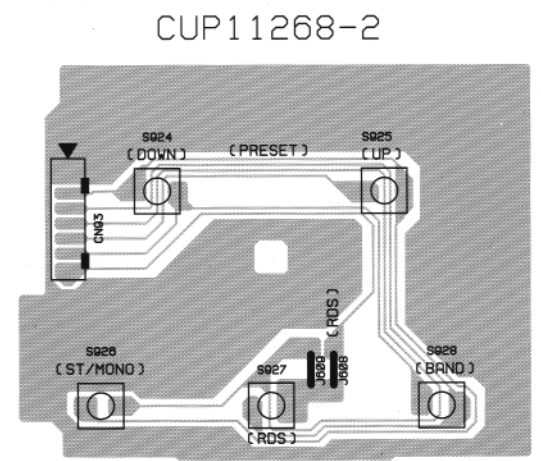

Q901 Q913 IC92 Q911 Q914 Q912 IC91
 Q903 Q902
 Q905
 Q906

IC22 : MC13022DW

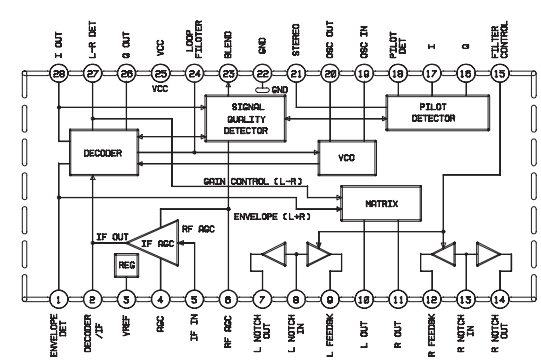

IC80 : TDA7330BD

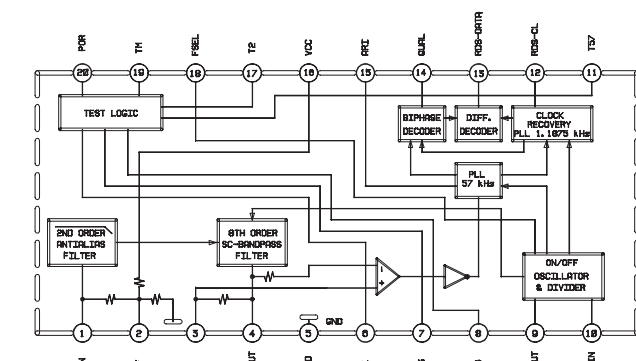

IC31 : LA3401

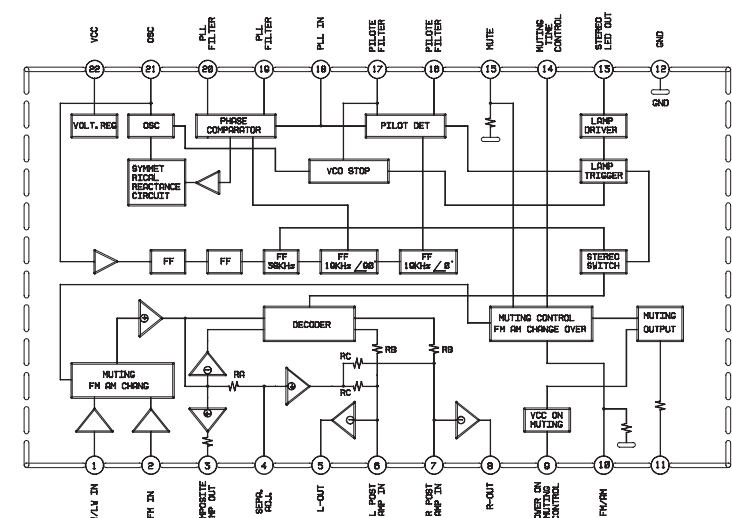

5. MICROPROCESSOR AND IC DATA

IC91 : TMP87PM78F

1. Pin Configuration

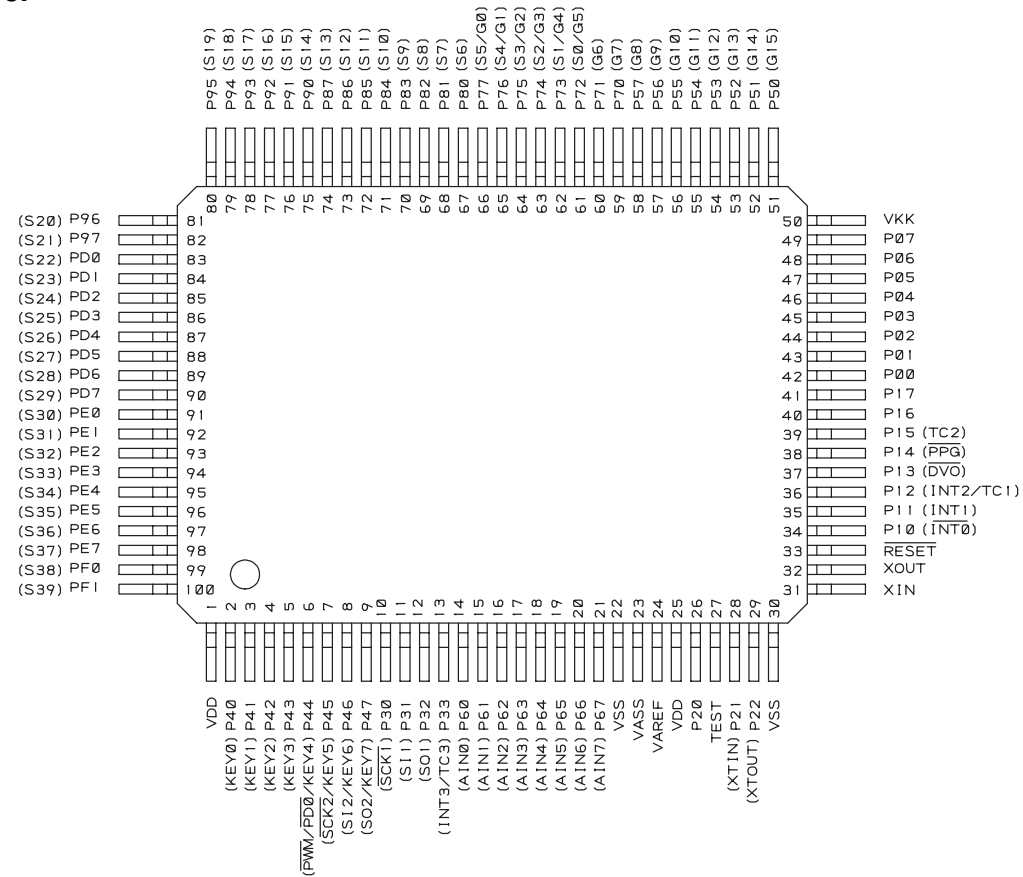

2. Block Diagram

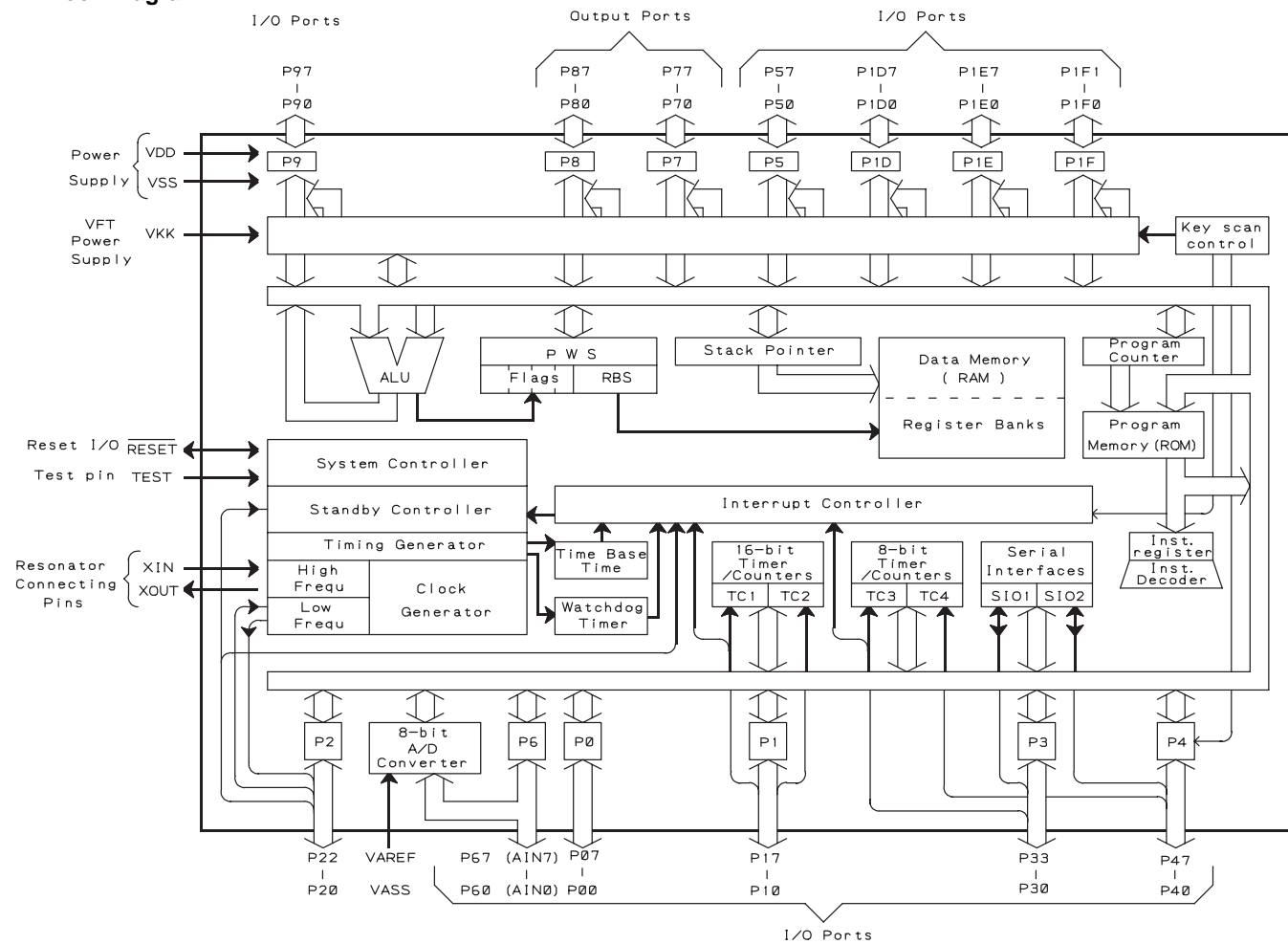

3. Pin Functions

PIN NO.	IN/OUT	MARK	DESCRIPTION OF TERMINAL																				
1	INPUT	VDD(+4.8V)	Power supply terminal																				
2~3	-		Not used in this unit.																				
4~8	OUTPUT	D3~D7	Output terminal for key																				
9	-		Not used in this unit.																				
10~13	INPUT	I1~I4	Input terminal for key																				
14	INPUT	SM IN	Signal Meter level IN																				
15	INPUT	TUNED	TUNED indicator drive																				
16	INPUT	ST IN	Stereo indicator drive																				
17~20	INPUT	AREA OPTION	Option terminal for area <table border="1" style="margin-left: 20px;"> <thead> <tr> <th></th> <th>/N1</th> <th>/U1</th> <th>/F1</th> </tr> </thead> <tbody> <tr> <td>17pin</td> <td>L</td> <td>H</td> <td>L</td> </tr> <tr> <td>18pin</td> <td>L</td> <td>L</td> <td>L</td> </tr> <tr> <td>19pin</td> <td>H</td> <td>L</td> <td>L</td> </tr> <tr> <td>20pin</td> <td>L</td> <td>L</td> <td>L</td> </tr> </tbody> </table>		/N1	/U1	/F1	17pin	L	H	L	18pin	L	L	L	19pin	H	L	L	20pin	L	L	L
	/N1	/U1	/F1																				
17pin	L	H	L																				
18pin	L	L	L																				
19pin	H	L	L																				
20pin	L	L	L																				
21	-		Not used in this unit.																				
22~23	-	GND	Ground terminal																				
24	INPUT	VREF	Reference power input terminal																				
25	INPUT	VDD	Power supply terminal																				
26	INPUT	BACK-UP(CE)	Power supply detection																				
27	-	GND	Ground terminal																				
28	INPUT	IN	Connecting terminal for crystal oscillator.																				
29	OUTPUT	OUT	The crystal connected is 32.768KHz.																				
30	-	GND	Ground terminal																				
31	INPUT	XIN	Connecting terminal for crystal oscillator.																				
32	OUTPUT	XOUT	The crystal connected is 8.00MHz.																				
33	INPUT	RESET	System reset terminal																				
34~35	INPUT	RMC IN	Remote control input terminal																				
36	INPUT	RDS CLOCK	Clock input terminal for RDS																				
37	INPUT	RDS DATA	Data input terminal for RDS																				
38	OUTPUT	RMC OUT	Remote control output terminal																				
39~43	-		Not used in this unit.																				
44	OUTPUT	MUTE	Mute Control Output																				
45	OUTPUT	POWER	Power on/off signal																				
46	OUTPUT	PDAO	Data output terminal for PLL IC(LC72131)																				
47	OUTPUT	PCE	Chip enable terminal for PLL IC(LC72131)																				
48	INPUT	PDAI	Data input terminal for PLL IC(LC72131)																				
49	INPUT	PCL	Clock input terminal for PLL IC(LC72131)																				
50	INPUT	Vfip	FIP drive voltage input																				
51~73	OUTPUT	P01~P23	FIP Anode driver outputs.																				
74	-		Not used in this unit.																				
75~87	OUTPUT	G01~G13	FIP Grde driver outputs.																				
88~90	-		Not used in this unit.																				
91	OUTPUT	POWER LED	Stand-by LED ON/OFF																				
92	OUTPUT	ANT A	ANT A LED ON/OFF																				
93	OUTPUT	ANT B	ANT B LED ON/OFF																				
94	OUTPUT	NARROW	NARROW LED ON/OFF																				
95	OUTPUT	WIDE	WIDE LED ON/OFF																				
96	-		Not used in this unit.																				
97~100	-	GND	Ground terminal																				

6. ADJUSTMENT PROCEDURE

ALIGNMENT INSTRUCTIONS

EQUIPMENT NEEDED

- * AM Signal Generator Dummy antenna(FM Adjustment)
- * FM Signal Generator * Stereo signal modulator
- * Oscilloscope * Distortion analyzer
- * VTVM(AC,DC)
- * Test loop antenna(MW Adjustment)

IMPORTANT

- 1.Check power-source voltage.
- 2.Set the function switch to band aligned.
- 3.Keep the function input as low as possible to adjust accurately.
- 4.Modulation and modulation frequency.

	Modulation	Modulation Frequency
MW(AM)/LW	30%	400Hz
FM	40kHz(EUR) 75kHz(USA,JPN)	400Hz

FM, MW/LW TRACKING VOLTAGE ADJUSTMENT

(FM) DC VOLTMETER

- * CONNECT TO TEST POINT TP11 and GND

(MW/LW) DC VOLTMETER

- * CONNECT TO TEST POINT TP11 and GND

NO	Band	Frequency	Adjust for	Adjustment
1	FM	87.50(76.00)MHz	1.6V	L7
2	MW	522/520kHz	1V	L204
3	LW	146kHz	1.3V	L205

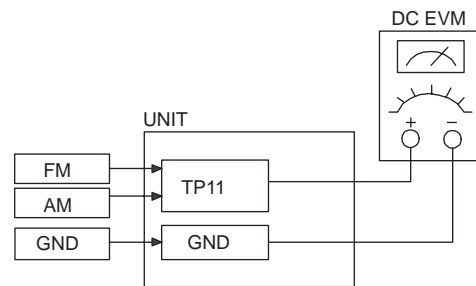

MW RF ADJUSTMENT

Signal generator : Connects to the MW Ant.

Coil through the loop antenna.

Adjust for the indication of VTVM of the wave form of scope to be maximum.

NO	Step	Freq.	Adjust for	Adjustment
MW (AM)	1	612/610kHz	Max sensitivity	L202(L203),T201,T202
	2	1503/1510kHz	Max sensitivity	CT21
	3	Repeat steps 1 and 2 several times.		
LW	1	164kHz	Max sensitivity	L203
	2	272kHz	Max sensitivity	CT22
	3	Repeat steps 1 and 2 several times.		

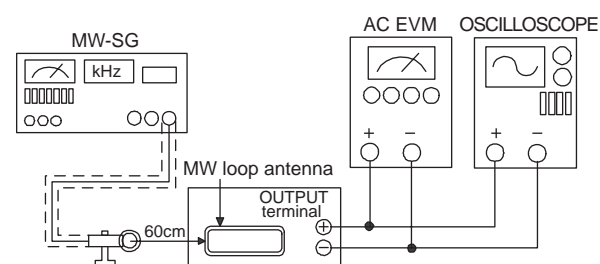

FM-RF ADJUSTMENT

Signal generator:Connects to FM ANT.JACK(FM IN) through the dummy.

NO	Frequency	Adjust for	Adjustment
1	90.10(79.10)MHz	Max sensitivity	L2,L5,L6
2	Repeat step 1 several times		

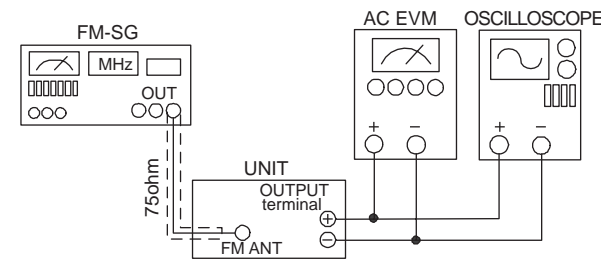

FM MONO DISTORTION ADJUSTMENT

DC VOLTMETER

- * Connect to TP12(-),TP13(+) through the choke coil(100uH).

Signal Generator

- * Connect to FM ANT Jack(FM IN) through the dummy.

Distortion Meter

- * Connect to the output.

NO	Frequency	Adjust for	Adjustment
1	100.10(83.10)MHz	DC Voltmeter 0V	T101
2	100.10(83.10)MHz	min T.H.D	T102
3	Repeat steps 1 and 2 several times		

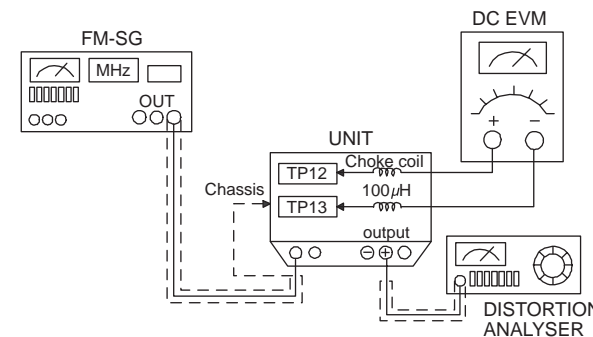

FM STEREO(WIDE/NARROW) SEPARATION

Pilot Signal	Adjust for	Adjustment
ON	Different of R and L must be maximum	VR31 (WIDE) VR32 (NARROW)

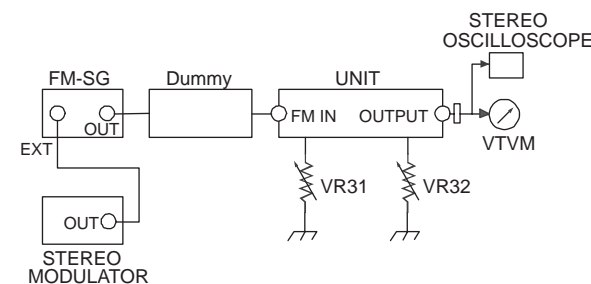

FM/MW(LW) AUTO STOP LEVEL ADJUSTMENT

FM SIGNAL GENERATOR : Connect to FM ANT Jack(FM IN) through the dummy

MW SIGNAL GENERATOR : Connect to MW ANT. Coil through Loop antenna

Band	Step	Signal Generator	Adjust for	Adjustment
FM	1	100.10(83.10)MHz 35dB	TUNED ON	VR11
	2	100.10(83.10)MHz 35dB	TUNED OFF	VR11
MW/LW (AM)	1	999(1000)kHz 80dB	TUNED ON	VR21
	2	999(1000)kHz 80dB	TUNED OFF	VR21

FM/MW(AM) SIGNAL METER LEVEL ADJUSTMENT

FM SIGNAL GENERATOR : Connect to FM ANT Jack(FM IN) through the dummy

MW SIGNAL GENERATOR : Connect to MW ANT. Coil through Loop antenna

Band	Signal Generator	Adjust for	Adjustment
FM	100.10(83.10)MHz 66dB	Signal Level:59~61dB FM(ANT A) IN	VR12
	MW (AM) 999(1000)kHz 100dB	Signal Level:75~80dB	VR22

ADJUSTMENT POINT

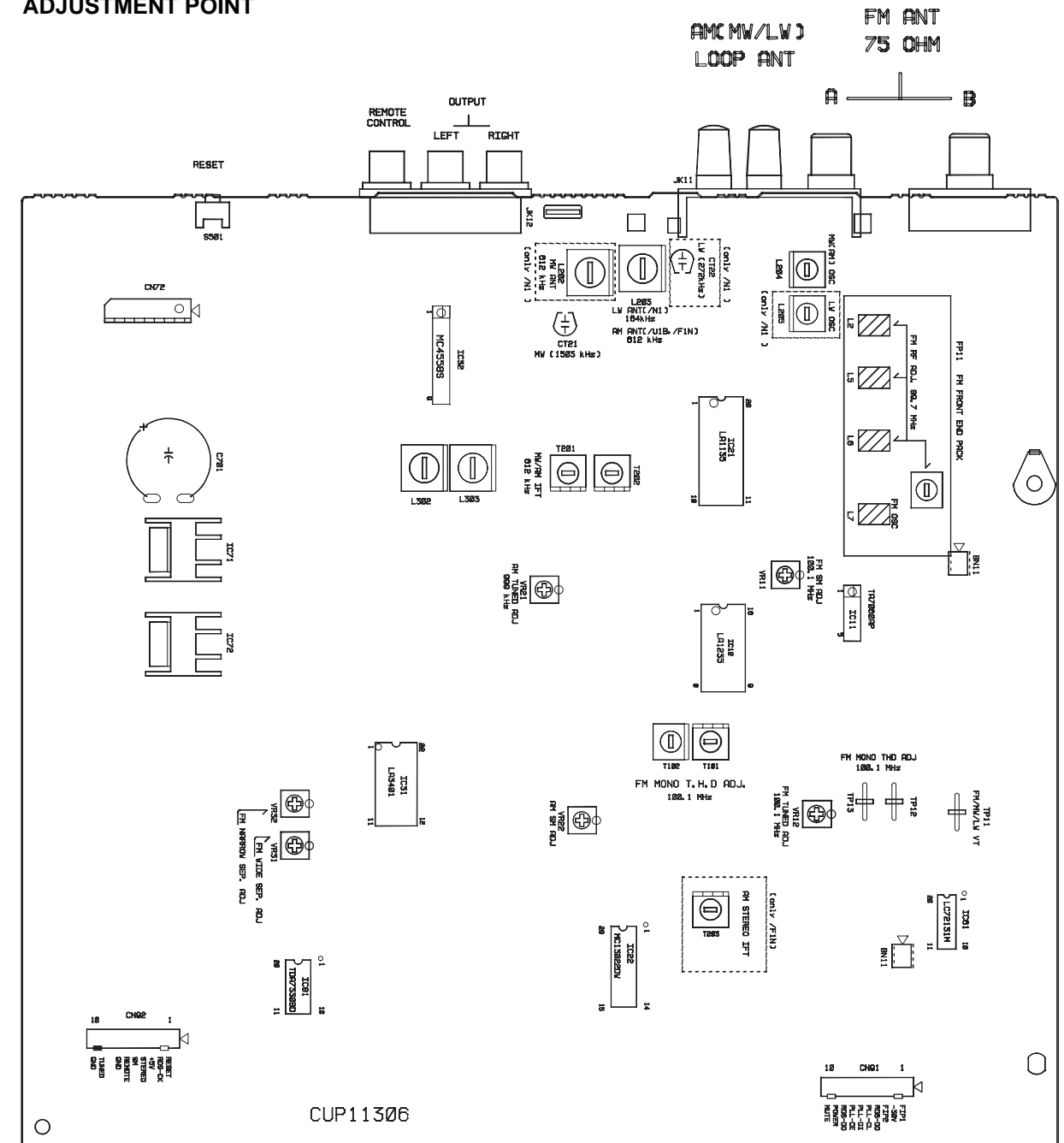

7. EXPLODED VIEW AND PARTS LIST

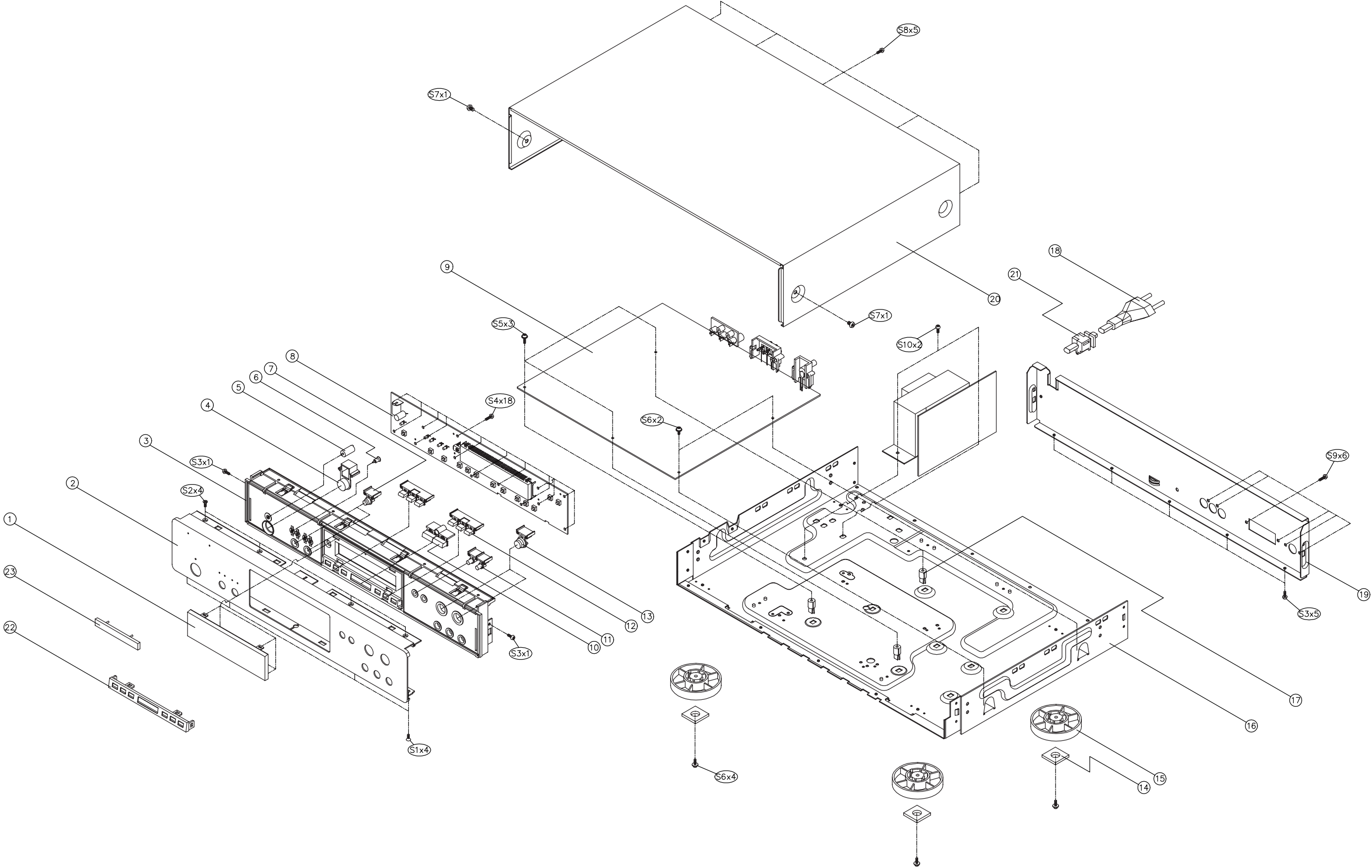

POS. NO	VERS. COLOR	PART NO. (PCS)	DESCRIPTION	PART NO. (MJI)
1		9965 000 01446	WINDOW FIP	282W158010
2	/U1B	nsp	PANEL FRONT (BLACK)	282W248010
2	/N1B	9965 000 01447	PANEL FRONT (BLACK)	282W248020
2	/F1N	nsp	PANEL FRONT (GOLD)	282W248110
2	/N1G	9965 000 01448	PANEL FRONT (GOLD)	282W248120
3	BLK	9965 000 01449	PANEL SUB (BLACK)	282W105010
3	GLD	9965 000 01450	PANEL SUB (GOLD)	282W105110
4	BLK	9965 000 01243	KNOB POWER (BLACK)	281W270010
4	GLD	9965 000 01451	KNOB POWER (GOLD)	281W270110
5		9965 000 01244	INDICATOR	285W355010
6		9965 000 01452	INDICATOR(LED)	282W355010
7	BLK	9965 000 01453	KNOB BAND (BLACK)	282W270040
7	GLD	9965 000 01454	KNOB BAND (GOLD)	282W270140
10		9965 000 01455	KNOB TUNING	282W270010
11	BLK	9965 000 01456	KNOB TIMER (BLACK)	282W270030
11	GLD	9965 000 01457	KNOB TIMER (GOLD)	282W270130
12		9965 000 01458	KNOB MODE	282W270020
13	BLK	9965 000 01459	KNOB PRESET (BLACK)	282W270050
13	GLD	9965 000 01460	KNOB PRESET (GOLD)	282W270150
15		4822 462 11013	FOOT	243W057010
16		nsp	CHASSIS BOTTOM A1-97-0391	nsp
17		nsp	MOUNT PCB A4-92-1728	nsp
▲ 18	N	9965 000 01306	MAINS CORD EUR	*YC000360R
▲ 18	F	nsp	MAINS CORD JPN	*YC000370R
▲ 18	U	nsp	MAINS CORD UL/CSA	*YC000380R
19	/F1N	nsp	PANEL REAR (GOLD)	nsp
19	/U1B	nsp	PANEL REAR (BLACK)	nsp
19	/N1G	nsp	PANEL REAR (GOLD)	nsp
19	/N1B	nsp	PANEL REAR (BLACK)	nsp
20	BLK	nsp	CABINET TOP (BLACK)	nsp
20	GLD	nsp	CABINET TOP (GOLD)	nsp
▲ 21		nsp	BUSHING MAINS CORD	nsp
22		9965 000 01461	ORNAMENT	282W053010
23		4822 454 11825	BADGE MARANTZ	185J251012
PACKING				
S1		nsp	SCREW	nsp
S2		nsp	SCREW	nsp
S3		nsp	SCREW	nsp
S4		nsp	SCREW	nsp
001T	F	nsp	USER GUIDE (JPN)	282W851110
001T	U	nsp	USER GUIDE (USA/CND)	282W851250
001T	N	9965 000 01462	USER GUIDE (EUR)	282W851310
001Z	U/F	nsp	REMOTE CONTOL UNIT RC6000ST	ZK282W0010
NOT STANDARD SPARE PARTS				
		nsp	BOX OUT CARTON	282W801010
		nsp	PAD SNOW	282W809010
	U/N	nsp	BATTERY	nsp
		nsp	CORD PIN (REMOTE)	nsp
		nsp	CORD PIN (STEREO)	nsp
	U/F	nsp	ADAPTOR 300 OHM MATCHING	nsp
	N	nsp	ANT FM WIRE	nsp
	U/F	nsp	ANT FM T	nsp
		nsp	LOOP ANT ASS'Y (LUG)	nsp

8.ELECTRICAL PARTS LIST

ASSIGNMENT OF COMMON PARTS CODES.

RESISTORS

R*** : 1) GD05 x x x 140, Carbon film fixed resistor, ±5% 1/4W
R*** : 2) GD05 x x x 160, Carbon film fixed resistor, ±5% 1/6W
 ↓
 ① Resistance value

Examples

① Resistance value
 0.1Ω 001 10Ω 100 1kΩ 102 100kΩ 104
 0.5Ω 005 18Ω 180 2.7kΩ 272 680kΩ 684
 1Ω 010 100Ω 101 10kΩ 103 1MΩ 105
 6.8Ω 068 390Ω 391 22kΩ 223 4.7MΩ 475

Note : Please distinguish 1/4W from 1/6W by the shape of parts used actually.

CAPACITORS

C*** : CERAMIC CAP.

3) DD1 x x x x 370, Ceramic capacitor
 ↓
 Disc type
 Temp. coeff. P350~N1000, 50V
 ↓
 ③ Capacity value
 ↓
 ② Tolerance

Examples

② Tolerance (Capacity deviation)

±0.25 pF 0
 ±0.5 pF 1
 ±5 % 5

Tolerance of COMMON PARTS handled here are as follows :

0.5 pF - 5 pF ± 0.25 pF
 6 pF - 10 pF ± 0.5 pF
 12 pF - 560 pF ... ± 5 %

③ Capacity value

0.5 pF 005 3 pF 030 100 pF 101
 1 pF 010 10 pF 100 220 pF 221
 1.5 pF 015 47 pF 470 560 pF 561

C*** : CERAMIC CAP.

4) DK16 x x x 300, High dielectric constant ceramic capacitor
 ↓
 Disc type
 Temp. chara. 2B4, 50V
 ↓
 ④ Capacity value

Examples

④ Capacity value

100 pF 101 1000 pF 102 10000 pF 103
 470 pF 471 2200 pF 222

C*** : 5) ELECTROLY CAP. () , 6) FILM CAP. ()

5) EA x x x x x 10, Electrolytic capacitor
 ↓
 One-way lead type, Tolerance ±20%
 ↓
 ⑥ Working voltage
 ↓
 ⑤ Capacity value

Examples

⑤ Capacity value

0.1 μF 104 4.7 μF 475 100 μF 107
 0.33 μF 334 10 μF 106 330 μF 337
 1 μF 105 22 μF 226 1100 μF 118
 2200 μF 228

⑥ Working voltage

6.3 V 006 25 V 025
 10 V 010 35 V 035
 16 V 016 50 V 050

6) DF15 x x x 350 → Plastic film capacitor
 DF15 x x x 310 → One-way type, Mylar ±5% 50V
 DF16 x x x 310 → Plastic film capacitor
 ↓
 One-way type, Mylar ±10% 50V
 ↓
 ⑦ Capacity value

Examples

⑦ Capacity value

0.001 μF (1000 pF) 102 0.1 μF 104
 0.0018 μF 182 0.56 μF 564
 0.01 μF 103 1 μF 105
 0.015 μF 153

NOTE 1) The above CODES (**R***** , **R***** , **C***** , **C***** and **C*****) are omitted on the schematic diagram in some case.
 2) On the occasion, be confirmed the common parts on the parts list.
 3) Refer to "Common Parts List" for the other common parts (**RI05**, **DD4**, **DK4**).

NOTE ON SAFETY FOR FUSIBLE RESISTOR :

The suppliers and their type numbers of fusible resistors are as follows ;

1 . KOA Corporation

Part No.(MJI)	Type No.(KOA)	Description
NH05 x x x 140	RF25S x x x x Ω	J ±5% (1/4W)
NH05 x x x 120	RF50S x x x x Ω	J ±5% (1/2W)
NH85 x x x 110	RF73B2A x x x x Ω	J ±5% (1/10W)
NH95 x x x 140	RF73B2E x x x x Ω	J ±5% (1/4W)



* Resistance value



Resistance value(0.1Ω - 10k Ω)

2. Matsushita Electronic Components Co., Ltd

Part No.(MJI)	Type No.(MEC)	Description
NF05 x x x 140	ERD-2FCJ x x x	(±5% 1/4W)
RF05 x x x 140		
NF02 x x x 140	ERD-2FCG x x x	(±2% 1/4W)
RF02 x x x 140		



* Resistance value

Examples



* Resistance value

0.1Ω 001 10Ω 100 1kΩ 102 100kΩ 104
 0.5Ω 005 18Ω 180 2.7kΩ 272 680kΩ 684
 1Ω 010 100Ω 101 10kΩ 103 1MΩ 105
 6.8 Ω 068 390 Ω 391 22kΩ 223 4.7MΩ 475

ABBREVIATION AND MARKS

ANT. : ANTENNA	BATT. : BATTERY
CAP. : CAPACITOR	CER. : CERAMIC
CONN. : CONNECTING	DIG. : DIGITAL
HP : HEADPHONE	MIC. : MICROPHONE
μ-PRO : MICROPROCESSOR	REC. : RECORDING
RES. : RESISTOR	SPK : SPEAKER
SW : SWITCH	TRANSF. : TRANSFORMER
TRIM. : TRIMMING	TRS. : TRANSISTOR
VAR. : VARIABLE	X' TAL : CRYSTAL

NOTE ON SAFETY:

Symbol  Fire or electrical shock hazard. Only original parts should be used to replaced any part marked with symbol  Any other component substitution (other than original type), may increase risk of fire or electrical shock hazard.

安全上の注意 :

 がついている部品は、安全上重要な部品です。必ず指定されている部品番号の部品を使用して下さい。

POS. NO	VERS. COLOR	PART NO. (PCS)	DESCRIPTION	PART NO. (MJI)	POS. NO	VERS. COLOR	PART NO. (PCS)	DESCRIPTION	PART NO. (MJI)
			SUB CIRCUIT BOARD		R962		nsp	1k Ω 1/5W	nsp
			CAPACITORS		R963		nsp	47k Ω 1/5W	nsp
C901		nsp	CER. 0.1 μ F 50V Z	nsp				SWITCHES	
C902		nsp	ELECT 1000 μ F 6.3V	nsp	S911		9965 000 01263	SW TACT	*SP000890R
C903		nsp	CER. 0.1 μ F 50V Z	nsp	}				
C911		nsp	CER. 22pF 50V J	nsp	S926	N	9965 000 01263	SW TACT	*SP000890R
C912		nsp	CER. 15pF 50V J	nsp	S927		9965 000 01263	SW TACT	*SP000890R
C913		nsp	CER. 12pF 50V J	nsp	S928		9965 000 01263	SW TACT	*SP000890R
C914		nsp	CER. 10pF 50V J	nsp				MISCELLANEOUS	
C923		nsp	ELECT 10 μ F 35V	nsp	BN72		nsp	WIRE ASS'Y 7P 220 mm	nsp
C924		nsp	ELECT 1 μ F 50V	nsp	BN91		nsp	WIRE ASS'Y 10P 200 mm	nsp
C925		nsp	CER. 0.1 μ F 50V Z	nsp	BN92		nsp	WIRE ASS'Y 10P 250 mm	nsp
C926		nsp	ELECT 22 μ F 25V	nsp	BN93		nsp	WIRE ASS'Y 7P 80 mm	nsp
C927		nsp	ELECT 1 μ F 50V	nsp					
C929		nsp	CER. 0.01 μ F 50V Z	nsp	▲ CN71		nsp	WAFER 7.92MM(YUNHO)	nsp
			DIODES		CN93		nsp	WAFER MOLEX 53014-0710	nsp
D901		4822 130 11608	LED RED SLR342VCF02	*HI100810R	FIP1		9965 000 01465	FLD HNA-13MS08	*HQ300390R
D902		4822 130 11608	LED RED SLR342VCF02	*HI100810R	▲ F701	N	nsp	HOLDER FUSE	nsp
D903		4822 130 11608	LED RED SLR342VCF02	*HI100810R	▲ F702	U/F	nsp	HOLDER FUSE	nsp
D905		4822 130 11608	LED RED SLR342VCF02	*HI100810R					
D906		4822 130 11608	LED RED SLR342VCF02	*HI100810R	OP01		nsp	WIRE COPPER	nsp
D910					OP02		nsp	WIRE COPPER	nsp
}		9965 000 01250	1SS131M	*HD201290R	OP03	F	nsp	WIRE COPPER	nsp
D914					OP04	U/F	nsp	WIRE COPPER	nsp
			INTEGRATED CIRCUIT						
IC91		9965 000 01463	MICROPROCESSOR	*HU100350R	C930		9965 000 01510	BACK UP CAPACITOR	*EX000050R
			TMP87CM78F-xxxx					0.1F 5.5V EECISOHD104V	
IC92		9965 000 01464	VOLTAGE DETECTOR	*HC105150R	RS91	U/F	nsp	IR SENSOR GP1U270R	*HW100420R
			RE5VL30CA-TZ		▲ T701	F	nsp	TRANS MAINS (JAPAN)	*TS001110R
			TRANSISTORS		▲ T701	N/U	9965 000 01466	100V 50Hz	*TS001120R
Q901		4822 130 62503	DTC114YS	*BA000730R				TRANS MAINS	
Q902		4822 130 62503	DTC114YS	*BA000730R	X901		4822 242 10855	120/230V 50/60Hz	
Q903		4822 130 62503	DTC114YS	*BA000730R	X902		4822 242 72236	CRYSTAL 8.0 MHz	*JX000410R
Q905		4822 130 62503	DTC114YS	*BA000730R				CRYSTAL 32.768 kHz DT-38	XO001001T2
Q906		4822 130 62503	DTC114YS	*BA000730R					
Q911		4822 130 62787	DTA114YS	*BA000190R				MAIN CIRCUIT BOARD	
Q912		4822 130 62503	DTC114YS	*BA000730R				CAPACITORS	
Q913		4822 130 60107	2SA933SR	HT109331S0	C101	N	nsp	CER. 15pF 50VJ	nsp
Q914		4822 130 62503	DTC114YS	*BA000730R	C102	N	nsp	CER. 15pF 50VJ	nsp
			RESISTORS		C103	N	nsp	CER. 15pF 50VJ	nsp
RA91		nsp	100 k Ω x 5 NETWORK	nsp	C104		nsp	ELECT 10 μ F 35V	nsp
▲ R751	U	nsp	3.3M Ω 1/2W	nsp	C107		nsp	CER. 0.01 μ F 50V Z	nsp
R901		nsp	390 Ω 1/5W	nsp	C108		nsp	CER. 15pF 50V J	nsp
R902		nsp	390 Ω 1/5W	nsp	C109		nsp	CER. 0.01 μ F 50V Z	nsp
R903		nsp	390 Ω 1/5W	nsp	C110		nsp	CER. 0.01 μ F 50V Z	nsp
R905		nsp	390 Ω 1/5W	nsp	C111		nsp	ELECT 10 μ F 35V	nsp
R906		nsp	390 Ω 1/5W	nsp	C112		nsp	CER. 0.01 μ F 50V Z	nsp
R908		nsp		nsp	C113		nsp	CER. 0.01 μ F 50V Z	nsp
}		nsp	47k Ω 1/5W	nsp	C114		nsp	CER. 0.01 μ F 50V Z	nsp
R912					C115		nsp	ELECT 10 μ F 35V	nsp
R920									
}		nsp	47k Ω 1/5W	nsp	C117		nsp	CER. 47pF 50V J	nsp
R923					C118		nsp	CER. 15pF 50V J	nsp
R931		nsp	1M Ω 1/5W	nsp	C120		nsp	CER. 0.047 μ F 50V Z	nsp
R951		nsp	1.2k Ω 1/5W	nsp	C121		nsp	CER. 0.047 μ F 50V Z	nsp
R952		nsp	100k Ω 1/5W	nsp	C122		nsp	CER. 0.047 μ F 50V Z	nsp
R953		nsp	390k Ω 1/5W	nsp	C123		nsp	ELECT 2.2 μ F 50V	nsp
R954		nsp	1.2k Ω 1/5W	nsp	C124		nsp	CER. 0.01 μ F 50V Z	nsp
R955		nsp	100k Ω 1/5W	nsp	C125		nsp	ELECT 1 μ F 50V	nsp
R956		nsp	1.2k Ω 1/5W	nsp	C126		nsp	ELECT 0.47 μ F 50V	nsp
R957		nsp	4.7k Ω 1/5W	nsp	C127		nsp	CER. 0.022 μ F 50V Z	nsp
R958		nsp	22k Ω 1/5W	nsp	C128		nsp	ELECT 220 μ F 16V	nsp
R959		nsp	470 Ω 1/5W	nsp	C131	N	nsp	CER. 0.01 μ F 50V Z	nsp
R960		nsp	47k Ω 1/5W	nsp	C132		nsp	CER. 220pF 50V K	nsp
R961		nsp	47k Ω 1/5W	nsp	C133	N	nsp	CER. 100pF 50V K	nsp

POS. NO	VERS. COLOR	PART NO. (PCS)	DESCRIPTION	PART NO. (MJ)	POS. NO	VERS. COLOR	PART NO. (PCS)	DESCRIPTION	PART NO. (MJ)
C134	N	nsp	CER. 100pF 50V K	nsp	C304		nsp	FILM 0.047 μ F 50V J	nsp
C135		nsp	CER. 0.01 μ F 50V Z	nsp	C305		nsp	CER. 470pF 50V K	nsp
C136		nsp	ELECT 220 μ F 16V	nsp	C306		nsp	ELECT 10 μ F 35V	nsp
C151		nsp	CER. 0.01 μ F 50V Z	nsp	C307		nsp	ELECT 0.1 μ F 50V	nsp
C152		nsp	CER. 0.01 μ F 50V Z	nsp	C308	N/F	nsp	CER. 560pF 50V K	nsp
C153		nsp	CER. 0.01 μ F 50V Z	nsp	C308	U	nsp	CER. 820pF 50V K	nsp
C154		nsp	CER. 0.01 μ F 50V Z	nsp	C309	N/F	nsp	CER. 560pF 50V K	nsp
C161		nsp	CER. 0.01 μ F 50V Z	nsp	C309	U	nsp	CER. 820pF 50V K	nsp
C162		nsp	ELECT 10 μ F 35V	nsp	C310		nsp	ELECT 0.1 μ F 50V	nsp
C163		nsp	CER. 0.01 μ F 50V Z	nsp	C311		nsp	ELECT 1 μ F 50V	nsp
C171	N	nsp	CER. 10pF 50V D	nsp	C312		nsp	ELECT 0.47 μ F 50V	nsp
C171	U/F	nsp	CER. 0.01 μ F 50V Z	nsp	C313		nsp	ELECT 3.3 μ F 50V	nsp
C201		nsp	SEMI 0.1 μ F 50V	nsp	C314		nsp	ELECT 1 μ F 50V	nsp
C202	N	nsp	CER. 15pF 50V J	nsp	C316	F	nsp	ELECT 2.2 μ F 50V	nsp
C203		nsp	FILM 0.047 μ F 50V J	nsp	C317	F	nsp	ELECT 2.2 μ F 50V	nsp
C204		nsp	ELECT 22 μ F 25V	nsp	C318		nsp	ELECT 2.2 μ F 50V	nsp
C205		nsp	CER. 0.022 μ F 50V Z	nsp	C319		nsp	ELECT 2.2 μ F 50V	nsp
C206		nsp	ELECT 3.3 μ F 50V	nsp	C320		nsp	ELECT 1 μ F 50V	nsp
C207		nsp	CER. 0.022 μ F 50V Z	nsp	C321		nsp	ELECT 1 μ F 50V	nsp
C208		nsp	CER. 1000pF 50V K	nsp	C322				
C209		nsp	SEMI 0.1 μ F 50V	nsp	}		nsp	ELECT 10 μ F 35V	nsp
C212		nsp	CER. 1000 pF 50V K	nsp	C325				
C213		nsp	CER. 1000pF 50V K	nsp	C340		nsp	ELECT 100 μ F 16V	nsp
C214		nsp	CER. 0.022 μ F 50V Z	nsp	C341		nsp	ELECT 10 μ F 35V	nsp
C215		nsp	ELECT 4.7 μ F 50V	nsp	C342		nsp	ELECT 1 μ F 50V	nsp
C216		nsp	ELECT 3.3 μ F 50V	nsp	C343		nsp	CER. 330pF 50V K	nsp
C217		nsp	CER. 1000pF 50V K	nsp	C347	F	nsp	ELECT 100 μ F 16V	nsp
C218		nsp	CER. 10pF 50V D	nsp	C351		9965 000 01469	ELECT 2.2 μ F 50V(N.P)	EQ22505030
C219		nsp	CER. 470pF 50V K	nsp	C601		nsp	ELECT 470 μ F 10V	nsp
C220	N	nsp	CER. 100pF 50V K	nsp	C602		nsp	CER. 0.01 μ F 50V Z	nsp
C221		nsp	CER. 0.022 μ F 50V Z	nsp	C603		nsp	CER. 27pF 50V J	nsp
C222		nsp	ELECT 220 μ F 16V	nsp	C604		nsp	CER. 27pF 50V J	nsp
C223	N	nsp	CER. 330pF 50V K	nsp	C605		nsp	CER. 0.01 μ F 50V Z	nsp
C224		nsp	CER. 0.047 μ F 50V Z	nsp	C611		nsp	ELECT 1 μ F 50V	nsp
C225	N	nsp	CER. 0.047 μ F 50V Z	nsp	C612		nsp	ELECT 0.1 μ F 50V	nsp
C226		nsp	ELECT 1 μ F 50V	nsp	C621				
C227		nsp	CER. 0.022 μ F 50V Z	nsp	}		nsp	CER. 100pF 50V K	nsp
C228		nsp	ELECT 1 μ F 50V	nsp	▲ C624		nsp		
C230	F	nsp	CER. 1000pF 50V K	nsp	C701		nsp	ELECT 3300 μ F 35V	nsp
C231	F	nsp	ELECT 100 μ F 16V	nsp	C702				
C232	F	nsp	CER. 0.022 μ F 50V Z	nsp	}		nsp	ELECT 220 μ F 35V	nsp
C233					C705				
}	F	nsp	CER. 1000pF 50V K	nsp	C706		nsp	CER. 680pF 50V K	nsp
C236					C707		nsp	CER. 680pF 50V K	nsp
C237	F	nsp	CER. 0.01 μ F 50V Z	nsp	C708		nsp	CER. 680pF 50V K	nsp
C238	F	nsp	ELECT 10 μ F 35V	nsp	C709		nsp	ELECT 47 μ F 50V	nsp
C239	F	nsp	ELECT 10 μ F 35V	nsp	C710		nsp	CER. 680pF 50V K	nsp
C240	F	nsp	ELECT 0.47 μ F 50V	nsp	C711		nsp	CER. 680pF 50V K	nsp
C241	F	nsp	ELECT 10 μ F 35V	nsp	C712		nsp	ELECT 47 μ F 50V	nsp
C242	F	nsp	ELECT 1 μ F 50V	nsp	C713		nsp	ELECT 47 μ F 50V	nsp
C243	F	nsp	SEMI 0.1 μ F 50V	nsp	C714		nsp	ELECT 3.3 μ F 50V	nsp
C245	F	nsp	CER. 56pF 50V J	nsp	C715		nsp	CER. 680pF 50V K	nsp
C246	F	nsp	CER. 0.01 μ F 50V Z	nsp	C720		nsp	CER. 0.022 μ F 50V Z	nsp
C247	F	nsp	ELECT 1 μ F 50V	nsp	C801	N	nsp	ELECT 220 μ F 16V	nsp
C248	F	nsp	ELECT 47 μ F 25V	nsp	C802	N	nsp	CER. 0.01 μ F 50V Z	nsp
C251	F	nsp	ELECT 0.22 μ F 50V	nsp	C805	N	nsp	ELECT 10 μ F 35V	nsp
C252	F	nsp	ELECT 0.22 μ F 50V	nsp	C806	N	nsp	CER. 0.01 μ F 50V Z	nsp
C253	F	nsp	ELECT 2.2 μ F 50V	nsp	C808	N	nsp	CER. 27pF 50V J	nsp
C254	F	nsp	ELECT 2.2 μ F 50V	nsp	C809	N	nsp	CER. 27pF 50V J	nsp
C255	F	nsp	FILM 0.047 μ F 50V J	nsp	C810	N	nsp	CER. 100pF 50V K	nsp
C256	F	nsp	FILM 0.047 μ F 50V J	nsp	C811	N	nsp	CER. 100pF 50V K	nsp
C257	F	nsp	ELECT 2.2 μ F 50V	nsp				FILTERS	
C258	F	nsp	ELECT 2.2 μ F 50V	nsp	CF11		9965 000 01467	FILTER CER.(FM) SFE107MX2H-A-T	*FF100260R
C261	F	nsp	ELECT 3.3 μ F 50V	nsp	CF12		9965 000 01468	FILTER CER.(FM) SFE107MZ2H-A-T	*FF100270R
C301		nsp	ELECT 220 μ F 16V	nsp	CF13		9965 000 01468	FILTER CER.(FM) SFE107MZ2H-A-T	*FF100270R
C302	N	nsp	FILM 0.015 μ F 50V J	nsp					
C302	U	nsp	FILM 0.033 μ F 50V J	nsp					
C303		9965 000 01469	ELECT 2.2 μ F 50V(N.P)	EQ22505030					

POS. NO	VERS. COLOR	PART NO. (PCS)	DESCRIPTION	PART NO. (MJI)	POS. NO	VERS. COLOR	PART NO. (PCS)	DESCRIPTION	PART NO. (MJI)
CF14		9965 000 01468	FILTER CER.(FM) SFE107MZ2H-A-T	*FF100270R	Q302		4822 130 63659	DTC143TS	*BA000700R
			DIODES		Q303		4822 130 63659	DTC143TS	*BA000700R
D101		9965 000 01250	1SS131M	*HD201290R	Q304		4822 130 61187	DTA144TS	BA10009210
D102		9965 000 01250	1SS131M	*HD201290R	Q306		4822 130 42594	DTC144ES	BA20012210
D103		4822 130 30621	1N4148	QP13030621	Q308		4822 130 63659	DTC143TS	*BA000700R
D111		9965 000 01250	1SS131M	*HD201290R	Q309		4822 130 63659	DTC143TS	*BA000700R
D112		9965 000 01250	1SS131M	*HD201290R	Q501		4822 130 62787	DTA114YS	*BA000190R
D113		9965 000 01250	1SS131M	*HD201290R	Q502		4822 130 61188	DTC144TS	BA20016210
D201		4822 130 82772	SVC321SPA-C-2	*HD400150R	Q601		4822 130 62787	DTA114YS	*BA000190R
D202	N	9965 000 01250	1SS131M	*HD201290R	Q602		4822 130 62787	DTA114YS	*BA000190R
D203	N	9965 000 01250	1SS131M	*HD201290R	▲ Q701		4822 130 11136	KTA1274Y	*HT100320R
D205		4822 130 30621	1N4148	QP13030621	Q702		4822 130 61188	DTC144TS	BA20016210
D206		4822 130 30621	1N4148	QP13030621				RESISTORS	
D301		4822 130 30621	1N4148	QP13030621	R101		nsp	47 Ω 1/5W	nsp
D302		9965 000 01250	1SS131M	*HD201290R	R104	N/U	nsp	5.6k Ω 1/5W	nsp
D501		9965 000 01250	1SS131M	*HD201290R	R105	N/U	nsp	6.8k Ω 1/5W	nsp
D601		9965 000 01250	1SS131M	*HD201290R	R106		nsp	150 Ω 1/5W	nsp
D602		9965 000 01250	1SS131M	*HD201290R	R108		nsp	6.8k Ω 1/5W	nsp
D603		4822 130 30621	1N4148	QP13030621	R109		nsp	10k Ω 1/5W	nsp
▲ D701					R110		nsp	330 Ω 1/5W	nsp
∫		4822 130 31878	1N4003	HD200010AR	R111		nsp	1k Ω 1/5W	nsp
▲ D705					R112		nsp	820 Ω 1/5W	nsp
▲ D710		4822 130 31878	1N4003	HD200010AR	R113		nsp	220 Ω 1/5W	nsp
▲ D711		4822 130 31878	1N4003	HD200010AR	R114		nsp	27k Ω 1/5W	nsp
▲ D712		9965 000 01470	ZENER 30V 1/2W	*HD301440R	R115		nsp	18k Ω 1/5W	nsp
▲ D713		9965 000 01471	ZENER 6.8V 1/2W	*HD301720R	R116		nsp	6.8k Ω 1/5W	nsp
D801	N	4822 130 30621	1N4148	QP13030621	R117		nsp	3.3k Ω 1/5W	nsp
D802		9965 000 01250	1SS131M	*HD201290R	R118		nsp	330 Ω 1/5W	nsp
D803		9965 000 01250	1SS131M	*HD201290R	R119		nsp	330 Ω 1/5W	nsp
			INTEGRATED CIRCUITS		R120		nsp	1k Ω 1/5W	nsp
IC11		9965 000 01476	IC TA7060AP	*HC105160R	R122		nsp	1k Ω 1/5W	nsp
IC12		4822 209 73726	IC LA1235	*HC105130R	R123		nsp	2.7k Ω 1/5W	nsp
IC21		4822 209 63917	IC LA1135	*HC105120R	R125		nsp	150 Ω 1/5W	nsp
IC22	F	nsp	IC MC13022DW	*HC105140R	R126		nsp	5.6k Ω 1/5W	nsp
IC31		4822 209 73434	IC LA3401	*HC105050R	R127		nsp	330 Ω 1/5W	nsp
IC32		9965 000 01402	IC MC4558S	*HC104120R	R130		nsp	10k Ω 1/5W	nsp
IC33	F	5322 209 10357	IC HEF4066BP	QQ20910357	R131		nsp	22k Ω 1/5W	nsp
IC61		4822 209 15778	IC LC72131M	*HC104820R	R132		nsp	2.7k Ω 1/5W	nsp
▲ IC71		4822 209 91033	IC KA7815-ABTU	*HC300220R	R133		nsp	2.7k Ω 1/5W	nsp
▲ IC72		4822 209 90086	IC KA7805-ABTU	*HC300210R	R134		nsp	22k Ω 1/5W	nsp
IC81	N	4822 209 33842	IC TDA7330B	*HC105170R	R151		nsp	6.8k Ω 1/5W	nsp
			TRANSISTORS		R152		nsp	6.8k Ω 1/5W	nsp
Q101		4822 130 62503	DTC114YS	*BA000730R	R153		nsp	3.3k Ω 1/5W	nsp
Q102		4822 130 61187	DTA144TS	BA10009210	R155		nsp	150k Ω 1/5W	nsp
Q103		4822 130 61187	DTA144TS	BA10009210	R156		nsp	10k Ω 1/5W	nsp
Q104					R158		nsp	5.6k Ω 1/5W	nsp
∫		4822 130 63385	KTC31920	*HT300480R	R160		nsp	1k Ω 1/5W	nsp
Q107					R161		nsp	1k Ω 1/5W	nsp
Q111		4822 130 62787	DTA114YS	*BA000190R	R162		nsp	680 Ω 1/5W	nsp
Q112		4822 130 62787	DTA114YS	*BA000190R	R163		nsp	220 Ω 1/5W	nsp
Q113		4822 130 62503	DTC114YS	*BA000730R	R164		nsp	27k Ω 1/5W	nsp
Q201		9965 000 01472	FET 2SK715	*HF200250R	R165		nsp	18k Ω 1/5W	nsp
Q202		4822 130 63485	KTC3198Y	*HT300690R					
Q203	N	4822 130 62503	DTC114YS	*BA000730R	R201		nsp	1M Ω 1/5W	nsp
Q204	N	4822 130 61189	DTC114TS	BA20017210	R202		nsp	1k Ω 1/5W	nsp
Q205	N	4822 130 61189	DTC114TS	BA20017210	R203		nsp	100k Ω 1/5W	nsp
Q206	N	4822 130 62503	DTC114YS	*BA000730R	R204		nsp	68 Ω 1/5W	nsp
Q207	N	4822 130 61189	DTC114TS	BA20017210	R205		nsp	68 Ω 1/5W	nsp
Q208	N	4822 130 61189	DTC114TS	BA20017210	R206		nsp	330 Ω 1/5W	nsp
Q209		4822 130 61189	DTC114TS	BA20017210	R207		nsp	68 Ω 1/5W	nsp
Q210		4822 130 61188	DTC144TS	BA20016210	R208		nsp	10k Ω 1/5W	nsp
Q211	F	4822 130 42594	DTC144ES	BA20012210	R209		nsp	10k Ω 1/5W	nsp
Q212	F	4822 130 63485	KTC3198Y	*HT300690R	R210		nsp	1k Ω 1/5W	nsp
Q213	F	4822 130 63485	KTC3198Y	*HT300690R	R211	N	nsp	1k Ω 1/5W	nsp
Q301		4822 130 62503	DTC114YS	*BA000730R	R212	N	nsp	2.2k Ω 1/5W	nsp
					R213		nsp	150 Ω 1/5W	nsp
					R214	N	nsp	2.2k Ω 1/5W	nsp

POS. NO	VERS. COLOR	PART NO. (PCS)	DESCRIPTION	PART NO. (MJI)	POS. NO	VERS. COLOR	PART NO. (PCS)	DESCRIPTION	PART NO. (MJI)
R215	N	nsp	4.7k Ω 1/5W	nsp	R345		nsp	2.2k Ω 1/5W	nsp
R216	N	nsp	10k Ω 1/5W	nsp	R346		nsp	100 Ω 1/5W	nsp
R217	U	nsp	39k Ω 1/5W	nsp	R351		nsp	47k Ω 1/5W	nsp
R217	N	nsp	91k Ω 1/5W	nsp	R352		nsp	47k Ω 1/5W	nsp
R218		nsp	5.6k Ω 1/5W	nsp	R501		nsp	100k Ω 1/5W	nsp
R220		nsp	2.2k Ω 1/5W	nsp	R502		nsp	10k Ω 1/5W	nsp
R221		nsp	22k Ω 1/5W	nsp	R511		nsp	10k Ω 1/5W	nsp
R222		nsp	47k Ω 1/5W	nsp	R601				
R223		nsp	27k Ω 1/5W	nsp			nsp	10k Ω 1/5W	nsp
R230	F	nsp	10k Ω 1/5W	nsp	R604				
R231	F	nsp	150 Ω 1/5W	nsp	R605		nsp	1k Ω 1/5W	nsp
R232	F	nsp	12k Ω 1/5W	nsp	R611		nsp	1k Ω 1/5W	nsp
R233	F	nsp	100k Ω 1/5W	nsp	R612		nsp	2.2k Ω 1/5W	nsp
R235	F	nsp	2.2k Ω 1/5W	nsp	R613		nsp	18k Ω 1/5W	nsp
R236	F	nsp	2.2k Ω 1/5W	nsp	R615		nsp	10k Ω 1/5W	nsp
R237	F	nsp	10k Ω 1/5W	nsp	R616		nsp	10k Ω 1/5W	nsp
R251	F	nsp	10k Ω 1/5W	nsp	R617		nsp	4.7k Ω 1/5W	nsp
R252	F	nsp	10k Ω 1/5W	nsp	R618		nsp	150 Ω 1/5W	nsp
R253	F	nsp	150k Ω 1/5W	nsp	▲ R701		4822 053 10109	10 Ω 1W J METAL	GA05100010
R254	F	nsp	150k Ω 1/5W	nsp	▲ R702		4822 053 10479	47 Ω 1W J METAL	GA05470010
R255	F	nsp	10k Ω 1/5W	nsp	R703		nsp	18k Ω 1/5W	nsp
					R704		nsp	4.7k Ω 1/5W	nsp
R256	F	nsp	10k Ω 1/5W	nsp	R711		nsp	47k Ω 1/5W	nsp
R257	F	nsp	3.9k Ω 1/5W	nsp	R712		nsp	330 Ω 1/5W	nsp
R258	F	nsp	3.9k Ω 1/5W	nsp	R713		nsp	10 Ω 1/5W	nsp
R259	F	nsp	680 Ω 1/5W	nsp	R714		nsp	47k Ω 1/5W	nsp
R260	F	nsp	680 Ω 1/5W	nsp	R715		nsp	4.7 Ω 1/5W	nsp
R261	F	nsp	47 Ω 1/5W	nsp	R716		nsp	4.7 Ω 1/5W	nsp
R301		nsp	150 Ω 1/5W	nsp	R801	N	nsp	150 Ω 1/5W	nsp
R302		nsp	3.9k Ω 1/5W	nsp	R802	N	nsp	1M Ω 1/5W	nsp
R303		nsp	3.3k Ω 1/5W	nsp					
R304		nsp	3.3k Ω 1/5W	nsp	VR11		9965 000 01270	TRIM. EVNDJAA03B15	*RA000930R
R306		nsp	91k Ω 1/5W	nsp	VR12		9965 000 01473	TRIM. EVNDJAA03B14	*RA000880R
R307		nsp	91k Ω 1/5W	nsp	VR21		9965 000 01473	TRIM. EVNDJAA03B14	*RA000880R
R308		nsp	10k Ω 1/5W	nsp	VR22		9965 000 01270	TRIM. EVNDJAA03B15	*RA000930R
R309		nsp	10k Ω 1/5W	nsp	VR31		9965 000 01270	TRIM. EVNDJAA03B15	*RA000930R
R310		nsp	150k Ω 1/5W	nsp	VR32		9965 000 01270	TRIM. EVNDJAA03B15	*RA000930R
R311		nsp	150k Ω 1/5W	nsp					
R312		nsp	3.3k Ω 1/5W	nsp					
R313		nsp	3.3k Ω 1/5W	nsp	▲ F701	N	4822 070 12001	FUSES	*FS000590R
R315		nsp	1k Ω 1/5W	nsp	▲ F702	F	4822 070 12001	T 200 mA 250V	*FS000590R
R316		nsp	47k Ω 1/5W	nsp	▲ F702	U	nsp	T 200 mA 250V	*FS000600R
R317		nsp	47k Ω 1/5W	nsp					
R318		nsp	47k Ω 1/5W	nsp					
R319		nsp	100k Ω 1/5W	nsp					
R320		nsp	100k Ω 1/5W	nsp					
R321		nsp	150 Ω 1/5W	nsp	L101	N	nsp	COIL	nsp
R322		nsp	3.3k Ω 1/5W	nsp	L133	N	4822 157 11873	COIL 18 mH	*LC107220R
R323		nsp	3.3k Ω 1/5W	nsp	L202	N	9965 000 01480	COIL MW ANT	*LA000130R
R324		nsp	100k Ω 1/5W	nsp	L203	N	9965 000 01481	COIL LW ANT	*LA000120R
R325		nsp	100k Ω 1/5W	nsp	L203	U/F	nsp	COIL AM ANT2	*TC000360R
R326	U/F	nsp	2.7k Ω 1/5W	nsp	L204		9965 000 01482	COIL AM OSC	*LO000080R
R326	N	nsp	5.6k Ω 1/5W	nsp	L205	N	9965 000 01483	COIL LW OSC	*LO000070R
R327	U/F	nsp	2.7k Ω 1/5W	nsp	L206		9965 000 01484	COIL 5.4 mH	*LC107260R
R327	N	nsp	5.6k Ω 1/5W	nsp	L207		nsp	COIL AXAIL 27 μH J	nsp
R328		nsp	100 Ω 1/5W	nsp	L302		4822 157 11487	COIL MPX	*LS000060R
R329		nsp	100 Ω 1/5W	nsp	L303		4822 157 11487	COIL MPX	*LS000060R
R330		nsp	1k Ω 1/5W	nsp	L701		9965 000 01235	COIL INDUCTOR 100 μH	*TC000350R
R331		nsp	1k Ω 1/5W	nsp					
R332		nsp	100k Ω 1/5W	nsp	S501		4822 276 14107	SWITCH	*SP000880R
R333		nsp	100k Ω 1/5W	nsp					
R334		nsp	100 Ω 1/5W	nsp					
R335		nsp	100 Ω 1/5W	nsp					
R340		nsp	330 Ω 1/5W	nsp					
R341		nsp	10k Ω 1/5W	nsp	BN11		nsp	MISCELLANEOUS	nsp
R342		nsp	10k Ω 1/5W	nsp	BPF1	N	9965 000 01474	WIRE ASS'Y	*FF100240R
R343		nsp	1k Ω 1/5W	nsp					
R344		nsp	100k Ω 1/5W	nsp	CF22		9965 000 01475	FILTER CER. SFG450E	*FF100280R
					CN72		nsp	WAFER MOLEX 5267-07A	nsp
					CN91		nsp	WAFER	nsp
					CN92		nsp	WAFER	nsp
					CT21		4822 125 11116	CAP VARIABLE	*CT000110R

POS. NO	VERS. COLOR	PART NO. (PCS)	DESCRIPTION	PART NO. (MJ)
CT22	N	4822 125 11116	CAP VARIABLE	*CT000110R
FP11	N/U	9965 000 01266	PACK FM FTA4460H	*AV000060R
FP11	F	nsp	PACK FM (JAPAN) FTA4508HJ	*AV000090R
JK11		9965 000 01477	TREMINAL,ANT (T/C 75 OHM)	*YT001630R
JK12		9965 000 01478	JACK 3P(R/W/O) DJB-573(NI)	*YT001840R
JK13		9965 000 01479	TERMINAL FM ANT (75 OHM)	*YT001830R
JW12		nsp	WIRE ASS'Y	nsp
TP11		nsp	WIRE COPPER	nsp
TP12		nsp	WIRE COPPER	nsp
TP13		nsp	WIRE COPPER	nsp
T101		9965 000 01485	IFT FM1	*LI000110R
T102		9965 000 01486	IFT FM2	*LI000120R
T201		9965 000 01487	IFT AM1	*LI000090R
T202		9965 000 01488	IFT AM2	*LI000100R
T203	F	nsp	IFT AM	*LI000080R
X201		4822 242 82242	RESONATOR LZU450C4N	*FF100190R
X202	F	nsp	RESONATOR CSA3.60MGF103	FQ03604020
X301		4822 242 11061	RESONATOR ZTB456F11	*FQ000390R
X601		4822 242 72333	CRYSTAL 7.2 MHz	JX07001261
X801	N	4822 242 11042	CRYSTAL 4.332 MHz	*JX000540R