

SERVICE
MANUAL

ST-64/ST64L



marantz

model ST-64 / ST-64L

Stereophonic Tuner

MARANTZ DESIGN AND SERVICE

Using superior design and selected high grade components, MARANTZ company has created the ultimate in stereo sound.

Only **original MARANTZ parts** can insure that your MARANTZ product will continue to perform to the specifications for which it is famous.

Parts for your MARANTZ equipment are generally available to our National Marantz Subsidiary or Agent.

ORDERING PARTS:

Parts can be ordered either by mail or by telex. In both cases, correct part number has to be specified. If you order by mail, fulfil MARANTZ order forms.

The following information must be supplied to eliminate delays in processing your order:

1. Complete address
2. Complete part numbers and quantities required
3. Description of parts
4. Model number for which part is required
5. Way of shipment
6. Signature: any order form or telex must be signed otherwise such part order will be considered as null and void.

PARTS ORDERING

Parts may be ordered at the following addresses:

AUSTRIA
HORNYPHON
Vertriebsgesellschaft GmbH
Wienerbergstrasse 1
A 1101 Wien
Austria
Telex: 132.332

AUSTRALIA
MARANTZ AUSTRALIA
PTY., Ltd.
19 Chard Road
Brookvale, NSW 2100
Australia
Telex: 24121

BELGIUM
SVD DIVISION MARANTZ
Industrialaan 1
1720 Groot-Bijgaarden
Belgium
Telex: 24466

CANADA
MARANTZ
DIVISION OF PHILIPS S.A.
AV. Santa Maria, 0760
Casilla 2687
Santiago
Telex: 240.239

DENMARK
MARANTZ
DIVISION OF PHILIPS
SERVICE A/S
Prags Boulevard 80
Postbox 1919
DK-2300 København S
Denmark
Telex: 31201

EIRE
MARANTZ IRELAND Ltd.
Newstead
Glonkeagh
Dublin 4
Telex: 25200

FINLAND
MARANTZ
DIVISION OF OY PHILIPS Ab
Kaivokatu 8
00100 Helsinki
Finland
Telex: 124811

FRANCE
MARANTZ FRANCE
4 Rue Bernard Palissy
92600 Asnières
France
Telex: 611651

GERMANY
MARANTZ GERMANY GmbH
Max-Planck-Strasse 22
6072 Dreieich 1
Germany
Telex: 529821

THE NETHERLANDS
MARANTZ
De Limiet 3
4131 NR Vianen
The Netherlands
Telex: 47679

NORWAY
MARANTZ
DIVISION OF PHILIPS A/S
Sandstuveien 40
Oslo 6
Norway
Telex: 72640

GREAT BRITAIN
MARANTZ AUDIO U.K. Ltd
Unit 15/16
Saxon Way Industrial Estate
Moor Lane
Harmondsworth UB7 OLW
Great Britain
Telex: 935196

GREECE
ADAMCO S.A.
P.O.Box 21025
Hippocratus Street 188
Athens 11410
Greece
Telex: 216.795

ITALY
MARANTZ ITALIANA S.p.A.
Via Monte Napoleone 10
20121 Milano
Italia

JAPAN
MARANTZ JAPAN, Inc.
35-1, 7-chome, Sagamiono
Sagamihara-shi, Kanagawa
Japan

KUWAIT
AL ALAMIAH ELECTRONICS
Ussama Building
Fahd al Saleem Street
P.O.Box 23781
Safat-Kuwait
Telex: 22694

SAUDI ARABIA
AL ALAMIAH ELECTRONICS
P.O.Box 5954
University Street
Riyadh 11432
Saudi Arabia
Telex: 201530

SOUTH AFRICA
MARANTZ
DIVISION OF PHILIPS S.A.
Rainer House
Ove Street, 10
Doomfontein
Johannesburg
Telex: 483.456

SPAIN
PHONO S.A.
Ignacio Iglesias 10
Badalona (Barcelona)
Spain
Telex: 59355

SWEDEN
MARANTZ
DIVISION OF PHILIPS
Försäljning AB
Tegeluddsvägen 1
S-115 84 Stockholm
Sweden
Telex: 14060

SWITZERLAND
DYNAVOX ELECTRONICS
Route de Villars 105
1701 Fribourg
Switzerland
Telex: 942377

TURKEY
DOGRUOL Ltd.
I.M.C.
6 Blok N°6310
Unkapani
Istanbul
Turkey
Telex: 22085

MALTA
CACHIA & GALEA
Republic Street, 68D
Valetta
Telex: 1682

U.S.A.
MARANTZ COMPANY, Inc.
National Service Department
P.O.Box 577
Chatsworth, CA 91311
U.S.A.

TECHNICAL ASSISTANCE

Should you require any other technical support, do not hesitate to contact the Technical Department of MARANTZ EUROPE & Co.

Avenue Louise 326 - Bte. 32

B-1050 Brussels

Belgium

Telephone: (02) 6407830 (10 l)

Telex: 26602

Fax.: (02) 649.29.20

All of the above locations are fully equipped to take care of your total service needs. Because various countries have differing configuration requirements, it is necessary that you contact the service facility in your particular country. In the event that there is no service location listed for your country, please, contact the nearest facility for the necessary assistance.

In case of difficulties, do not hesitate to contact the Technical Department at abovementioned address.

marantz®

TABLE OF CONTENTS

SECTION	PAGE
INTRODUCTION	1
1. P.W. BOARDS	1
2. TEST EQUIPMENT REQUIRED FOR SERVICING	2
3. TUNER ALIGNMENT PROCEDURES	2
4. TEST POINT AND ALIGNMENT POINTS	4
5. CIRCUIT DESCRIPTION	5
5.1 μ PD1704C-552 (Q501)	5
5.2 OUTLINE OF FUNCTIONS	7
5.3 CONFIGURATION OF KEY MATRIX	7
5.4 DESCRIPTION OF KEY MATRIX	8
5.5 DIODE MATRIX INITIAL SETTINGS	8
5.6 INDICATORS	9
6. VOLTAGE CONVERSION	10
7. BLOCK DIAGRAM	11
8. SCHEMATIC DIAGRAM AND COMPONENT LOCATIONS	12
8.1 Preset Switch Assembly (PT00) Schematic Diagram and Component Locations	12
8.2 Display Assembly (P900) Schematic Diagram and Component Locations	13
8.3 Mode Lamp Assembly (PR00) Schematic Diagram and Component Locations	13
8.4 Power/Mode Assembly (PS00) Schematic Diagram and Component Locations	13
8.5 Tuner Assembly (P100) Schematic Diagram and Component Locations	14
8.6 IF Band Assembly (PU00) Schematic Diagram and Component Locations	15
9. EXPLODED VIEW AND PARTS LIST	20
10. ELECTRICAL PARTS LIST	23
11. TECHNICAL SPECIFICATIONS	29
12. SCHEMATIC DIAGRAM	30

MODEL ST-64/ST-64L STEREOPHONIC TUNER

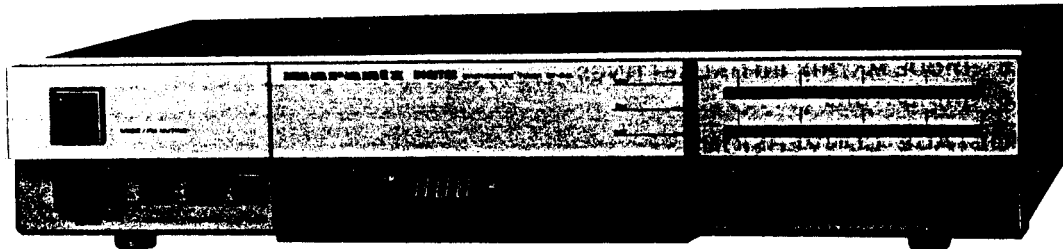
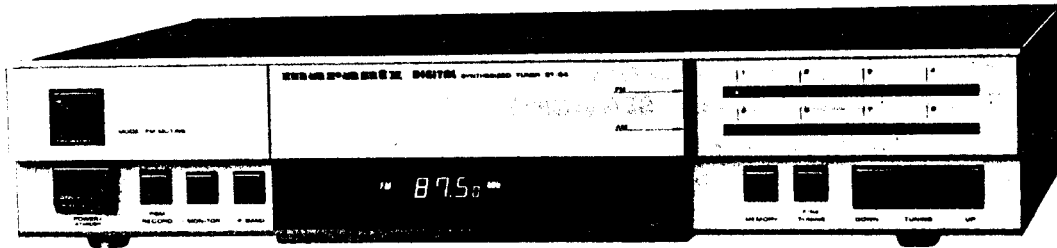

INTRODUCTION

This service manual was prepared for use by Authorized Warranty Stations and contains service information for Marantz Model ST-64/ST-64L Stereophonic Tuner.

Servicing information and voltage data included in this manual are intended for use by the knowledgeable and experienced technician only. All instructions should be read carefully. No attempt should be made to proceed without a good understanding of the operation of the Tuner.

The parts list furnishes information by which replacement parts may be ordered from the Marantz Company. A simple description is included for parts which can usually be obtained through local suppliers.

1. P.W. BOARDS

As can be seen from the circuit diagram the chassis of Model ST-64/ST-64L consists of the following units. Each unit mounted on a printed circuit board is described within the square enclosed by a bold dotted line on the circuit diagram.

1. Tuner mounted on P.W. Board P100
2. Display mounted on P.W. Board P900
3. Mode Lamp mounted on P.W. Board PR00
4. Power/Mode mounted on P.W. Board PS00
5. Preset Switch mounted on P.W. Board PT00
6. IF Band mounted on P.W. Board PU00

2. TEST EQUIPMENT REQUIRED FOR SERVICING

Item	Use
AM Signal Generator	Signal source for AM alignment
Test Loop	Use with AM signal generator
FM Signal Generator	Signal source for FM alignment
MPX Signal Generator	Stereo separation alignment and trouble shooting
Distortion Analyzer	Distortion measurements
Audio Oscillator	Sinewave and squarewave signal source
AC VTVM	Voltage measurements (AC)
Oscilloscope	Waveform analysis and trouble shooting and ASO alignment
Frequency Counter	MPX oscillator adjustment (VCO)
Circuit Tester	Trouble shooting
DC VTVM	Voltage measurements (DC)
AC Wattmeter	Monitors primary power to tuner
Line Voltmeter	Monitors potential of primary power to tuner
Variable Autotransformer (0 ~ 140V AC, 10A)	Adjusts level of primary power to tuner

3. TUNER ALIGNMENT PROCEDURES

A dummy resistor of 47 kohms must be connected across the tuner output terminals before alignment.

FM Alignment Procedures

(Function switch in the "FM" position, MODE/FM MUTING Switch in the MONAURAL/MUTING OFF position.)

1. FM RF Alignment (IF BAND switch in the "WIDE" position.)

Step	Signal Source Connection	Signal Frequency	Indicator Connection	Set the Digital Readout Frequency	Adjust:
1	FM signal generator to FM antenna terminal (300 ohm) through matching network Set the SG RF output level so that some noise can be observed on the upper and lower side of the output waveform.	98.00 MHz	VTVM to L or R channel output (J102)	98.00 MHz	FRONT END IFT (L9) for maximum output and minimum distortion.
2	FM signal generator 1 mV output to FM antenna terminal (300 ohm) through matching network Modulation Level IHF 75 kHz DEV. DIN 40 kHz DEV.	98.00 MHz	"O" center meter or DC current meter in 100 μ A range between (J100 1, 2)	98.00 MHz	L202 core so that the meter indicates its center or may read "O".
3	FM signal generator 1 mV output to FM antenna terminal (300 ohm) through matching network Modulation Level IHF 75 kHz DEV. DIN 40 kHz DEV.	98.00 MHz	"O" center meter or DC current meter in 100 μ A range between (J200 1, 2)	98.00 MHz	L203 (Primary) core so that the meter indicates its center or may read "O".
4	FM signal generator 1 mV output to FM antenna terminal (300 ohm) through matching network.	98.00 MHz	Distortion meter to L or R channel output (J102)	98.00 MHz	L203 (Secondary) core for minimum distortion.

2. FM IF Alignment Procedures

(Function switch in the "FM" position, MODE/FM MUTING switch in the AUTO STEREO/MUTING ON position.)

IF BAND switch in the "WIDE" position.

Step	Signal Source Connection	Signal Frequency	Indicator Connection	Set the Digital Readout Frequency	Adjust:
1	FM signal generator 1 mV output modulated by MPX signal generator to FM antenna terminal (300 ohm) through matching network Modulation Level IHF 67.5kHz+9%Pilot DEV. DIN 40kHz +8% Pilot DEV.	No modulation	Frequency counter to (J300 1, 2)	98.00 MHz	R334 so that Frequency may precisely read 76,000 kHz (V.C.O)
2		Stereo left (1,000 Hz)	VTVM to left channel output (J102 L ch)		FRONT END IFT (L9) for minimum distortion
3		Stereo right (1,000 Hz)	VTVM to right channel output (J102 R ch)		

IF BAND switch in the "NARROW" position.

Step	Signal Source Connection	Signal Frequency	Indicator Connection	Set the Digital Readout Frequency	Adjust:
1	FM signal generator 1 mV output modulated by MPX signal generator to FM antenna terminal (300 ohm) through matching network Modulation Level IHF 67.5kHz+9%Pilot DEV. DIN 40kHz +8% Pilot DEV.	Stereo left (1,000 Hz)	VTVM to left channel output (J102 L ch)	98.00 MHz	L201 for minimum distortion
2		Stereo right (1,000 Hz)	VTVM to right channel output (J102 R ch)		
3	RF generator to FM antenna terminals through matching network (300 ohms, balanced) with the RF signal level set so that the signal strength LED may light 4 points at IF band switch "Wide"	98.00 MHz		98.00 MHz	IF Band switch "Narrow" R216 so that signal strength LED may light 4 points. (DT12)

3. Muting Level Alignment

(Function switch in the "FM" position, MODE/FM MUTING switch in the AUTO STEREO/MUTING ON position.)

IF BAND switch in the "WIDE" position.

Step	Signal Source Connection	Signal Frequency	Indicator Connection	Set the Digital Readout Frequency	Adjust:
1	FM signal generator 12.5 μV output to FM antenna terminal through matching network (300 ohm, balanced)	98.00 MHz	VTVM to L or R channel output (J102)	98.00 MHz	Adjust R233 until output is developed.

4. Multiplex Alignment Procedures

(Function switch in the "FM" position, MODE/FM MUTING switch in the AUTO STEREO/MUTING ON position.)

Step	Signal Source Connection	Signal Frequency	Indicator Connection	Set the Digital Readout Frequency	Adjust:
1	FM signal generator 1 mV output modulated by MPX signal generator to FM antenna terminal (300 ohm) through matching network Modulation Level IHF 67.5kHz+9%Pilot DEV. DIN 40kHz +8% Pilot DEV.	Stereo left (1,000 Hz)	VTVM to right channel output (J102 R ch)	98.00 MHz	IF BAND WIDE R326 NARROW R325 for same separation in both channels.
2		Stereo right (1,000 Hz)	VTVM to left channel output (J102 L ch)		
3	Repeat steps 1 and 2.				
4	RF generator to FM antenna terminals through matching network (300 ohms, balanced) with 1 mV FM stereo signal.	Pilot only	VTVM to right and left channel output (J102)		R330 so that minimum output should be the same in both channels

AM Alignment Procedures (Function switch in the "AM" position.)

1. AM IF Alignment

Step	Signal Source Connection	Signal Frequency	Indicator Connection	Set the Digital Readout Frequency	Adjust:
1	Sweep generator to AM Antenna Terminal.	450 kHz marker	Oscilloscope to J300 (2, 3)	—	LA05 for maximum and symmetric response.

2. AM RF Alignment

Step	Signal Source Connection	Signal Frequency	Indicator Connection	Set the Digital Readout Frequency	Adjust:
1	Apply the signal to the AM loop antenna from the AM signal generator using the test loop.	600 kHz	VTVM to L or R channel output (J102)	600 kHz	LA01 for maximum output.
2		1,400 kHz		1,400 kHz	CA02-1 for maximum output.
3	Repeat steps 1 and 2.				

3. LW RF Alignment (Function in the "LW" position)

Step	Signal Source Connection	Signal Frequency	Indicator Connection	Set the Digital Readout Frequency	Adjust:
1	Apply the signal to the AM loop antenna from the RF generator using the test loop.	173 kHz	VTVM to L or R channel output (J102)	173 kHz	LA02 for maximum output.
2		272 kHz		272 kHz	CA02-2 for maximum output.
3	Repeat steps 1 and 2 as necessary to obtain maximum sensitivity.				

4. AM Signal Alignment (Function switch in the "AM" position)

Step	Signal Source Connection	Signal Frequency	Indicator Connection	Set the Digital Readout Frequency	Adjust:
1	Apply a signal to the AM loop antenna from the RF generator via the test test loop. (5 mV/m)	1,000 kHz	—	1,000 kHz	Adjust RA23 so that 5 signal LEDs light. (DT13)

4. TEST POINT AND ALIGNMENT POINTS

PI00
YK459HI6I-0

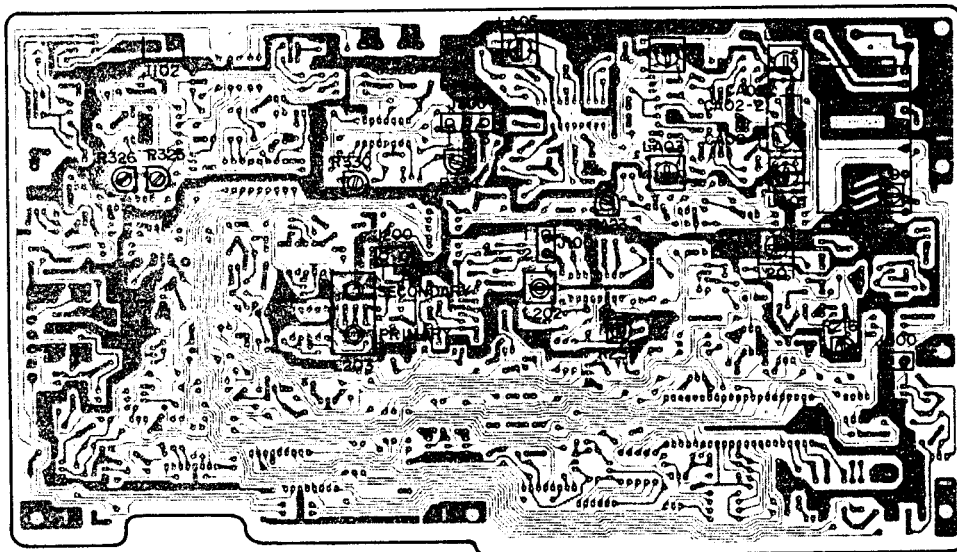

AM Alignment Procedures (Function switch in the "AM" position.)

1. AM IF Alignment

Step	Signal Source Connection	Signal Frequency	Indicator Connection	Set the Digital Readout Frequency	Adjust:
1	Sweep generator to AM Antenna Terminal.	450 kHz marker	Oscilloscope to J300 (2, 3)	—	LA05 for maximum and symmetric response.

2. AM RF Alignment

Step	Signal Source Connection	Signal Frequency	Indicator Connection	Set the Digital Readout Frequency	Adjust:
1	Apply the signal to the AM loop antenna from the AM signal generator using the test loop.	600 kHz	VTVM to L or R channel output (J102)	600 kHz	LA01 for maximum output.
2		1,400 kHz		1,400 kHz	CA02-1 for maximum output.
3	Repeat steps 1 and 2.				

3. LW RF Alignment (Function in the "LW" position)

Step	Signal Source Connection	Signal Frequency	Indicator Connection	Set the Digital Readout Frequency	Adjust:
1	Apply the signal to the AM loop antenna from the RF generator using the test loop.	173 kHz	VTVM to L or R channel output (J102)	173 kHz	LA02 for maximum output.
2		272 kHz		272 kHz	CA02-2 for maximum output.
3	Repeat steps 1 and 2 as necessary to obtain maximum sensitivity.				

4. AM Signal Alignment (Function switch in the "AM" position)

Step	Signal Source Connection	Signal Frequency	Indicator Connection	Set the Digital Readout Frequency	Adjust:
1	Apply a signal to the AM loop antenna from the RF generator via the test loop. (5 mV/m)	1,000 kHz	—	1,000 kHz	Adjust RA23 so that 5 signal LEDs light. (DT13)

4. TEST POINT AND ALIGNMENT POINTS

P100

YK459HI61-0

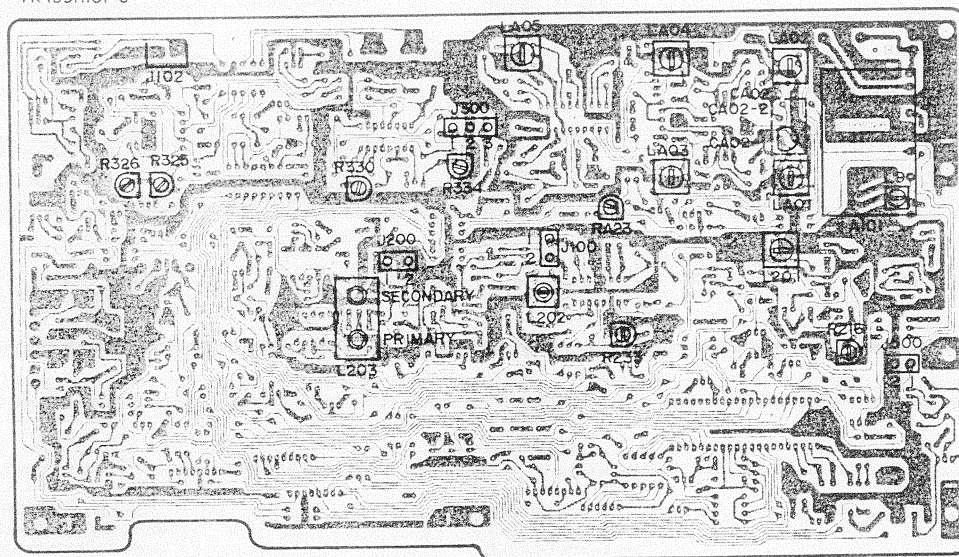

5. CIRCUIT DESCRIPTION

5.1 μ PD1704C-552 (Q501)

1. SINGLE-CHIP MICROPROCESSOR CONTAINING PLL FREQUENCY SYNTHESIZER FOR μ PD1704C-552 (Q501) AM/FM TUNER

● Absolute Maximum Ratings

Item	Symbol	Ratings	Unit
Supply voltage	V_{DD}	-0.3 ~ +6.0	V
Input voltage	V_I	-0.3 ~ + V_{DD}	V
Output voltage	V_O	-0.3 ~ + V_{DD}	V
Output absorption current	I_O	10	mA
Operating temperature	T_{opt}	-35 ~ +75	°C
Storage temperature	T_{stg}	-55 ~ +125	°C
Output withstand voltage	V_{BDS}	Across Sa and Sg terminals (voltage across drain and source)	V

● Recommended Operation Range

Item	Symbol	Condition	Min.	Typ.	Max.	Unit
Supply voltage	V_{DD}		4.5	5.0	5.5	V
Data (RAM) holding voltage	V_{RAM}	CE=0, CLOCK STOP instruction execution	3.0		5.5	V
Oscillation stop supply voltage	V_{DDS}			3.2	3.8	V
Output withstand voltage	V_{BDS}	Across Sa and Sg terminals (voltage across drain and source) $I_{OH} = -5 \mu A$			-30	V
Rise time of supply voltage	T_{rise}	$V_{DD} = 0 \rightarrow 4.5V$			500	ms

● Electrical Characteristics ($V_{DD} = +4.5 \sim +5.5V$, $T_a = -35 \sim +75^\circ C$)

Item	Symbol	Condition	Min.	Typ.	Max.	Unit
High-level input voltage	V_{IH1}	SD, INT terminal	$0.8V_{DD}$		V_{DD}	V
High-level input voltage	V_{IH2}	I/O port, CE terminal	$0.7V_{DD}$		V_{DD}	V
High-level input voltage	V_{IH3}	$K_0 \sim K_3$ terminal	$0.6V_{DD}$		V_{DD}	V
Low-level input voltage	V_{IL1}	I/O port, CE terminal	0		$0.3V_{DD}$	V
Low-level input voltage	V_{IL2}	$K_0 \sim K_3$, SD, INT terminal	0		$0.2V_{DD}$	V
High-level output voltage	V_{OH1}	EO_1, EO_2 terminal $I_{OH} = -0.5mA$	4.0			V
High-level output voltage	V_{OH2}	$D_1 \sim D_6, MT/D_7$, I/O port $I_{OH} = -0.2mA$	4.0			V
High-level output voltage	V_{OH3}	PSC terminal $I_{OH} = -0.1mA$	4.0			V
High-level output voltage	V_{OH4}	Sa ~ Sg terminal $I_{OH} = -0.5mA$	3.0			V
Low-level output voltage	V_{OL1}	EO_1, ED_2 terminal, I/O port $I_{OL} = 0.5mA$			0.5	V
Low-level output voltage	V_{OL2}	$D_1 \sim D_6, MT/D_7$, PSC terminal $I_{OL} = 0.2mA$			0.5	V
High-level input current	$+I_{IH1}$	$K_0 \sim K_3$ terminal $V_{IN} = V_{DD} = 5.0V$	25	50	100	μA
High-level input current	$+I_{IH2}$	X_1 terminal (in pull down) $V_{IN} = V_{DD} = 5.0V$		300		μA
Low-level input current	$-I_{IL1}$	AM, FM terminal (in pull up) $V_{IN} = 0, V_{DD} = 5.0V$		300		μA
Output leak current	I_L	EO_1, EO_2 terminal, $T_a = 25^\circ C$		10^{-3}	1	μA
Response frequency	f_{AM}	AM terminal, $V_{in} = 1.0 V_{p-p}$ (MIN.), DC cut	0.5		2.5	MHz
Response frequency	f_{FM}	FM terminal, $V_{in} = 0.8 V_{p-p}$ (MIN.), DC cut	0.5		8.8	MHz
Operating current	I_{DD1}	Excluding I/O current from I/O terminals		3		mA
Data (RAM) holding current	I_{DD2}	CE=0, CKSTP instruction execution, $T_a = 25^\circ C, V_{DD} = 5.0V$			10	μA

● Pin Connections

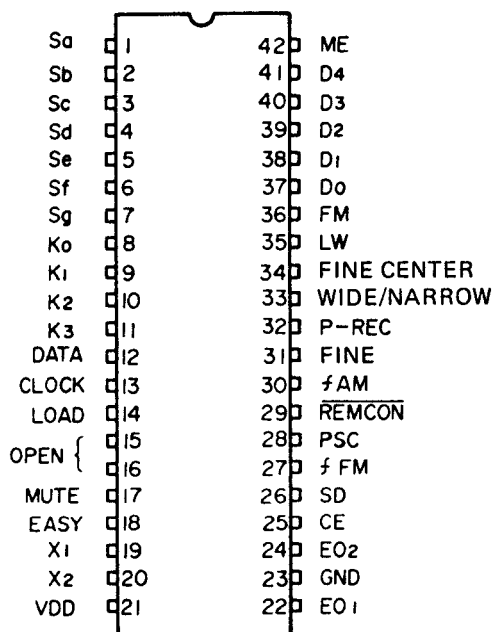

● Functions of Terminal

Pin No.	Symbol	Name	Function
1 ~ 7	Sa to Sg	Segment output	Key return signal source terminal, active at the high level.
8 ~ 11	K ₀ ~ K ₃	Key return signal input	Key return signal input terminal from the remote key matrix.
12 ~ 14	DATA CLOCK LOAD		Display data output terminals connected to static display driver QR01.
17	MUTE	Mute	Muting output terminal to kill shocks and noise that are caused when PLL is out of lock.
18	EASY		The high level is outputted for about 100 ms when the band, up/down and preset memory keys are depressed (output terminal for easy operation).
19, 20	X ₁ , X ₂	X'tal	Quartz crystal oscillator connection terminal (4.5 MHz).
21	V _{DD}	V _{DD}	Device power terminal.
22	EO ₁	Error output	Phase detector charge pump output.
23	GND	Ground	Connected to the system ground.
25	CE	Chip enable	Low level in back-up, high level with the device operated in standard form.
26	SD	Station detector	Inputs auto tuning stop signal.
27	f _{FM}	FM local oscillator signal inputs	Inputs output (1/16, 1/17) into which FM local oscillator output is divided by prescaler Q502.
28	PSC	Prescaler control	Outputs division ratio change-over signal to the prescaler when the pulse swarrow method is used for division.
29	REMCON		Remote-control input terminal, active at the low level.
30	f _{AM}	AM local oscillator signal inputs	Inputs MW/LW local oscillator output.
31	FINE		HIGH level when Fine Tuning can be adjusted.
32	P-REC		High level in preset record enable mode.
33	WIDE/ NARROW		This indicates whether the FM IF band is WIDE or NARROW. HIGH level at WIDE setting.
34	FINE CENTER		HIGH level when the frequency is at the center. LOW level when the frequency has been shifted by fine tuning control.
35	LW		Outputs the high level when the LW band is currently received.
36	FM		Outputs the high level when the FM band is currently received.
37 ~ 41	D ₀ ~ D ₄		Display data output terminal to dot display driver UPD6322C.
42	ME		Outputs the high level in memory enable mode.

5.2 OUTLINE OF FUNCTIONS

● Receiving Band

Three bands of FM, MW and LW can be received in Europe, and two bands of FM and AM in Japan and the U.S.A.

Destination	Type of Band	Receiving Frequency Range	Channel Space	Reference Frequency	Intermediate Frequency
Europe	MW	531 ~ 1602 kHz	9 kHz	9 kHz	450 kHz
	LW	153 ~ 281 kHz	1 kHz	1 kHz	450 kHz
	FM	87.50 ~ 108.00 MHz	50 kHz	10 kHz	10.7 MHz
U.S.A.	AM	520 ~ 1610 kHz	10 kHz	10 kHz	450 kHz
	FM	87.5 ~ 108.0 MHz	100 kHz	10 kHz	10.7 MHz
Japan	AM	531 ~ 1602 kHz	9 kHz	9 kHz	450 kHz
	FM	76.0 ~ 90.0 MHz	100 kHz	10 kHz	10.7 MHz

● Channel Selecting Function

- (1) Automatic Up/Down Tuning (sawtooth wave mode)
A channel is selected at a speed of approx. 60 ms/step until high-level input is developed at pin (26) of the SD terminal.
- (2) Manual Up/Down Tuning (sawtooth wave mode)
Single-finger depression of the momentary switch allows stepwise forward, and continuous depression for 0.5 second or longer runs the tape fast forward at approx. 60 ms/step.
- (3) Preset Memory Access
FM 8 channels, M1 ~ M8
LW/MW . . . 8 channels, M1 ~ M8 in random access

● Preset Memory Write

A frequency being currently received is written by depressing the preset key while the ME lamp is lit.

● Programmable Preset Recording Function

Programs can be reserved up to six channels in FM, MW and LW bands by the memory and preset keys while the PRG-REC lamp is lit.



Whenever the chip enable signal changes from high to low level during operation of the PRG-REC lamp, a channel is accessed in the order of reservation. Reserved channels are displayed every second when the MONITOR key is depressed in that state.

● Remote Control Function

The following actions are allowed by remote control.

- (1) Preset memory access
- (2) Band change-over
- (3) Manual/automatic up/down channel selection

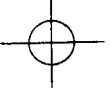
5.3 CONFIGURATION OF KEY MATRIX

	K ₃	K ₂	K ₁	K ₀	Type of Key
S _a	M1	M2	M3	M4	Momentary switch 
S _b	M5	M6	M7	M8	
S _c	UP	DOWN	MEMO		
S _d	P-REC	FINE	MONI		
S _e	MW (AM)	FM	LW	WIDE/NARROW	Initialize diode matrix 
S _f	BAND 2	BAND 1		N/N + 2	
S _g				LW	

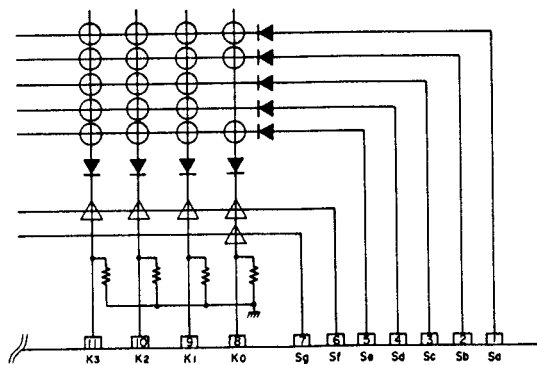

5.4 DESCRIPTION OF KEY MATRIX

● Momentary Key

(1) M1 ~ M8

These function as the preset memory data write-in keys, preset call-out keys, and unattended recording reservation keys.

(a) Data Write (Excluding P-REC mode)

Press any one of the M1 ~ M8 keys within approximately 5 seconds after the MEMO key is pressed (while the ME indicator is lit up). The frequency presently being received, the WIDE/NARROW data (FM only), and the FINE mode (FM only) will be written into the memory area corresponding to the key depressed.

(b) Preset Call

When any one of the M1 ~ M8 keys is pressed, the memory contents (frequency, WIDE/NARROW, FINE) corresponding to the key pressed will be called out. Up to 8 FM presets can be programmed and called out, and 8 MW/LW presets can be programmed and called at random.

(c) Preset recording program reservation

A program can be reserved by depressing any one of the M1 ~ M8 keys within about 5 seconds after depression of the MEMO key in P-REC mode. Programs can be reserved up to six channels in FM, MW and LW bands at random. An ordinary access to the memory is taken unless the ME lamp is lit even in P-REC mode.

(2) MEMO

The key shows preset memory write mode or preset recording program reservation enable mode. When the key is depressed, the ME lamp is lit for about 5 seconds and enable mode is set.

(3) UP/DOWN

Automatic/manual channel selection key (sawtooth wave mode).

(a) Manual

Frequency is stepped up or down (channel step) whenever the key is depressed. Continuous depression of these keys for about 0.5 second or longer allows continuous forward of the tape at about 60 ms/step.

(b) Automatic

When the key is released with continuous forward run in manual mode, frequency is automatically stepped up or down. Scanning is stopped when the high level is inputted to the SD (station detector) terminal or when these keys are redepressed.

(c) FINE TUNING

Pressing either key when the FINE mode is activated, will shift the frequency up or down in 10 kHz steps (display will not change).

Fine tuning range: Japan, America -40 kHz ~ +50kHz
Europe ±20 kHz

The mute output will not function when the above limits are exceeded.

(4) FINE (FM only)

Pressing this key will cause the FINE indicator to light up, indicating that fine tuning can be carried out.

The FINE mode can be cancelled by pressing the FINE key once again, pressing the UP or DOWN keys or pressing any other key excluding the ME keys.

(5) P-REC

The P-REC lamp comes on with the key depressed to display preset record enable mode. Redepression of the key clears the same mode. The UP/DOWN key does not function in P-REC mode.

(6) MONITOR

The key operates only in P-REC mode. When the key is depressed, the contents of reserved programs are displayed every second and the tape stops in the last.

(7) FM, MW (AM) and LW

When any one of these keys is depressed, a last channel of a band corresponding to the depressed key is accessed. However, the LW key is ignored if LW null is selected on the diode matrix.

(8) WIDE/NARROW (FM only)

WIDE or NARROW will be selected alternately each time this key is pressed.

The WIDE/NARROW mode can be entered into the preset memory (for FM only).

5.5 DIODE MATRIX INITIAL SETTINGS

(1) BAND 1, BAND 2

Determine the region of use.

	U.S.A.	Europe	Japan
BAND 1	0	0	1
BAND 2	0	1	1

1: Diode installed
0: Open

(2) LW

Install a diode when the LW band is received.

(3) N/N+2

Determines the frequencies which can be received when SD checks are performed at 9 kHz intervals.

1: (9 x N) 153, 162, 171, , 270, 279 (kHz)
0: (9 x N+2) 155, 164, 171, , 272, 281 (kHz)

5.6 INDICATORS

(1) Indicators are static displays using the μ PD6320G.

Output order	1	2 ~ 12	13 ~ 16	17 ~ 20	21 ~ 24	25 ~ 28	29 ~ 32
Display contents	Internal flag	Flags D11 to D1	BCD 10 MHz or 100 kHz	BCD 1 MHz or 10 kHz	BCD 100 kHz or 1 kHz	BCD Preset station	BCD Preset station

The internal flag is always "1" (High).

D11	' 0) FM station interval in Europe: 50 kHz
D10	S Common to S and D.	
D9	- 5	
D8	D.P.		
D7	kHz		
D6	MHz		
D5	ME		
D4	MW		
D3	FM		
D2	LW		
D1	/ Most significant digit displayed	

The data, clock, load signals are output from pins 12, 13, and 14, respectively.

V901 (Fluorescent display tube)

Pin assignments

Pin number		1	2	3	4	5	6	7	8	9	10	11	12	13	14	15	16	17	18
Electrode connected	HQ30903060	F	b ₅ c ₅	a ₄	f ₄	e ₄	d ₄	c ₄		g ₄	b ₄	a ₃	f ₃	e ₃	d ₃	c ₃	g ₃	b ₃	a ₂
	HQ31002060	F	b ₅ c ₅	a ₄	f ₄	e ₄	d ₄	c ₄		g ₄	b ₄	a ₃	f ₃	e ₃	d ₃	c ₃	g ₃	b ₃	a ₂

Pin number		19	20	21	22	23	24	25	26	27	28	29	30	31	32	33	34	35
Electrode connected	HQ30903060		f ₂	e ₂	d ₂	c ₂	g ₂	b ₂	b ₁ e ₁	g ₁	kHz	MHz	FM Dp	AM	a ₁ d ₁ c ₁ f ₁	G	G	F
	HQ31002060		f ₂	e ₂	d ₂	c ₂	g ₂	b ₂	b ₁ e ₁	g ₁	kHz	MHz	FM Dp a ₁ c ₁ d ₁ f ₁	MW	LW	G	G	F

V901
HQ30903060
(ST-64)

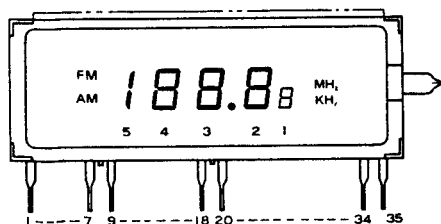

V901
HQ31002060
(ST-64L)

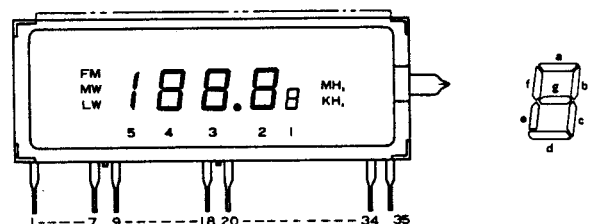

6. VOLTAGE CONVERSION

• EUROPEAN MODEL ONLY

To convert the unit to a different power source voltage, change the position as illustrated in the drawing below.

CAUTION
DISCONNECT POWER SUPPLY CORD FROM AC
OUTLET BEFORE CONVERTING VOLTAGE.

Voltage Conversion Chart

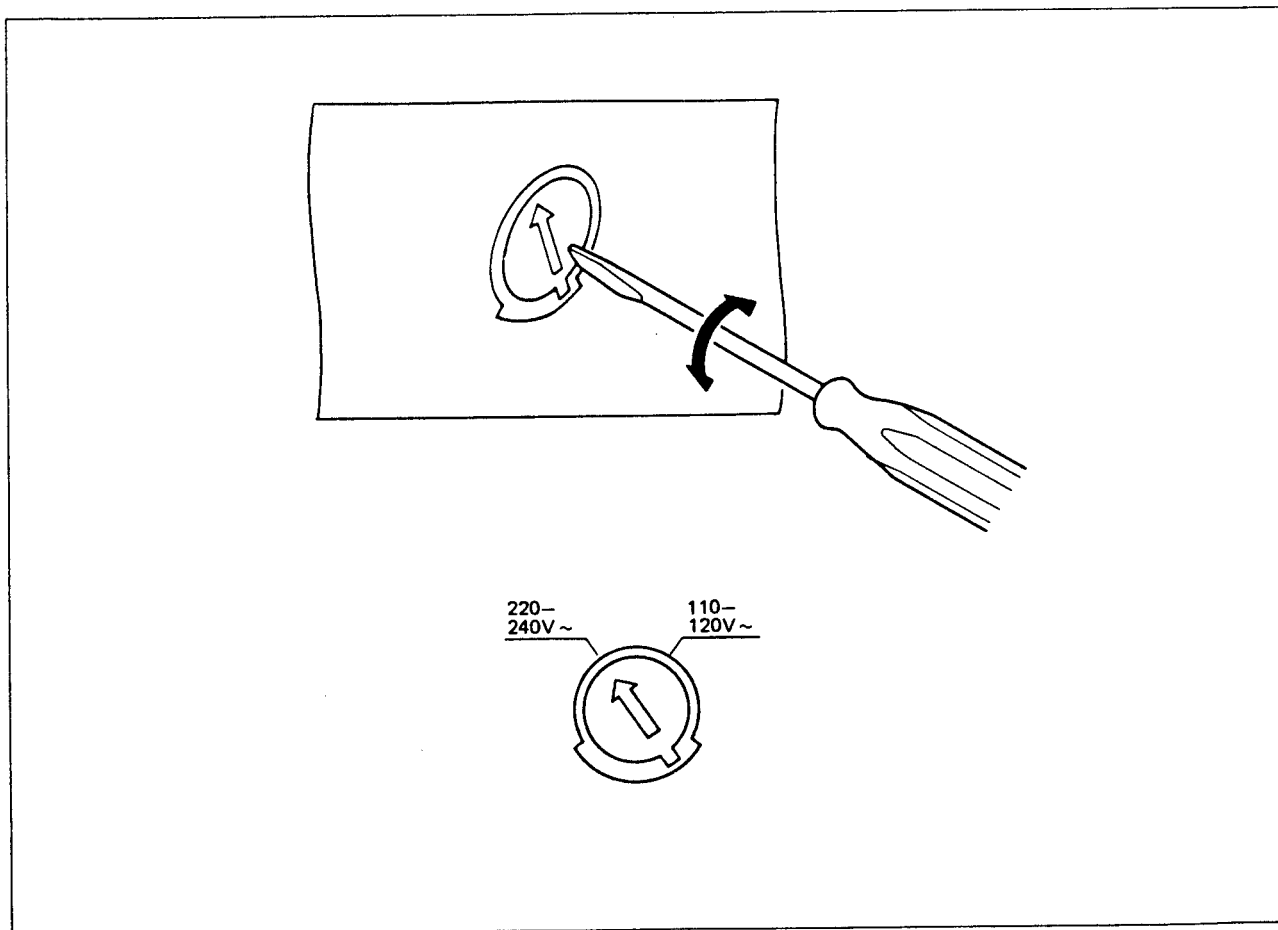

Note on safety: Symbol \triangle Fire or electrical shock hazard. Only original parts should be used to replace any part marked with symbol \triangle . Any other component substitution (other than original type), may increase risk of fire or electrical shock hazard.

7. BLOCK DIAGRAM

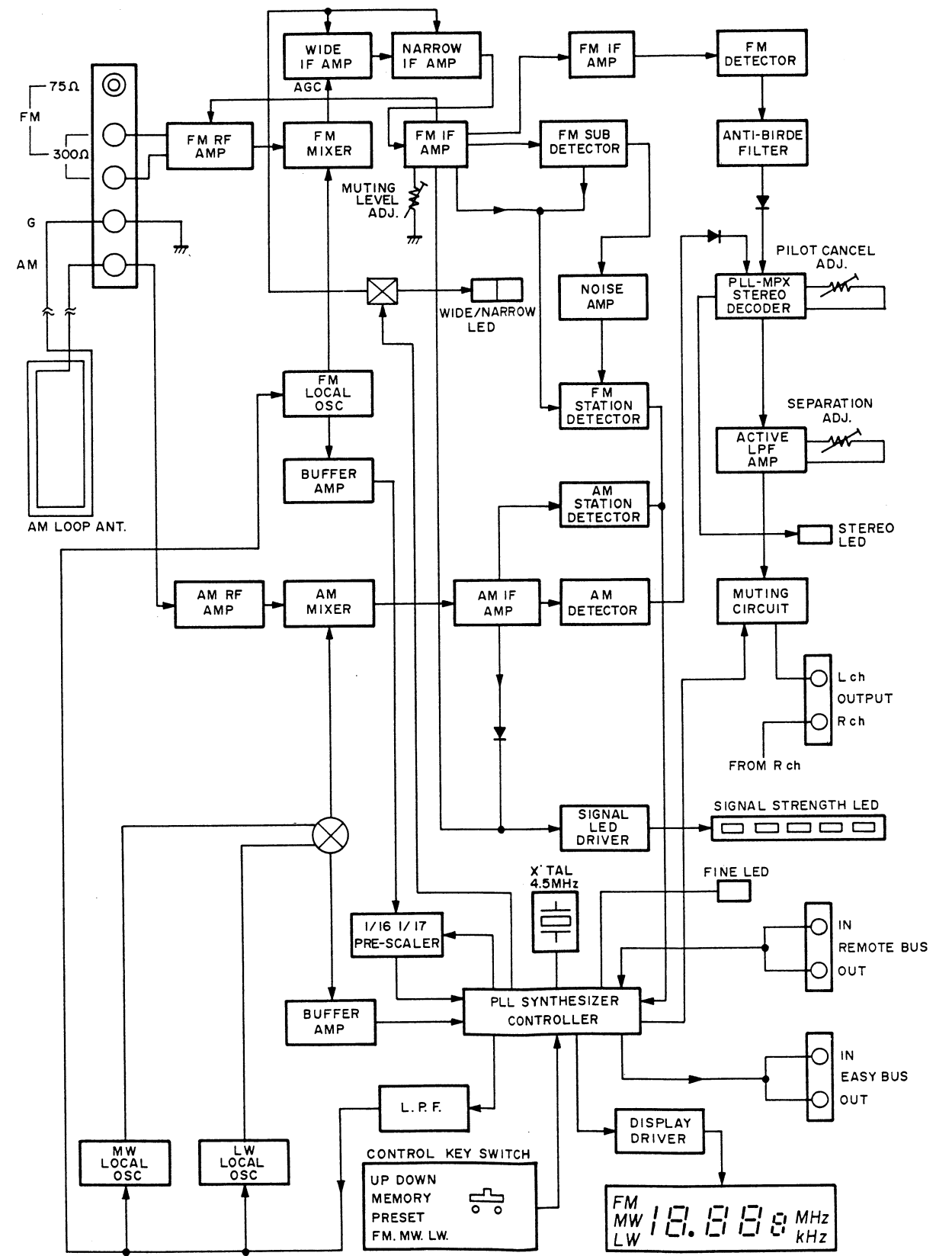

8. SCHEMATIC DIAGRAM AND COMPONENT LOCATIONS

8.1 Preset Switch Assembly (PT00) Schematic Diagram and Component Locations (Model ST-64)

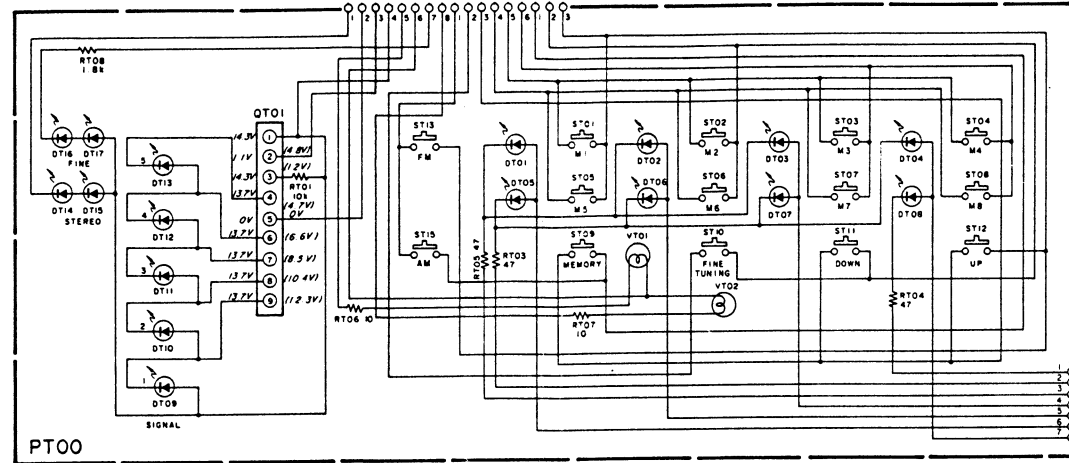

(Model ST-64L)

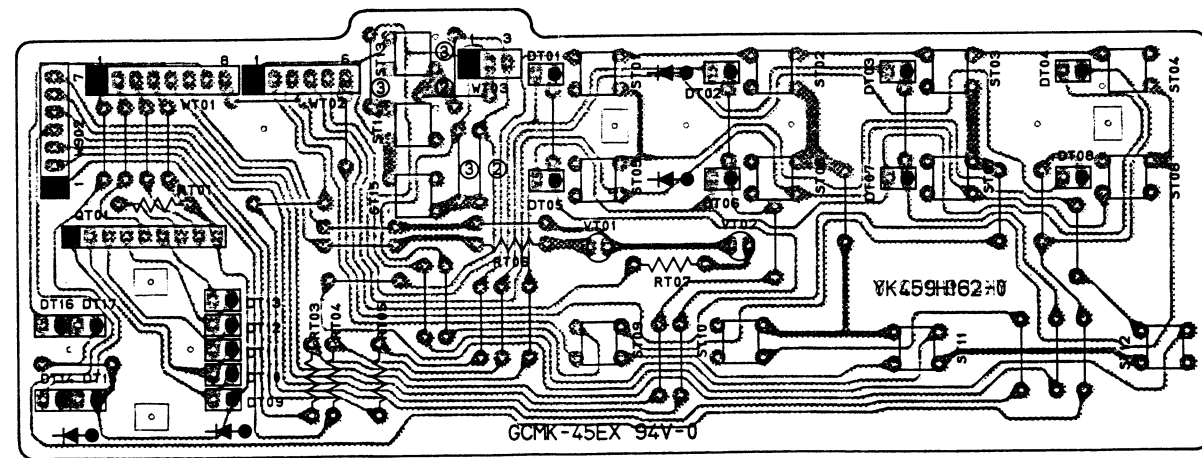
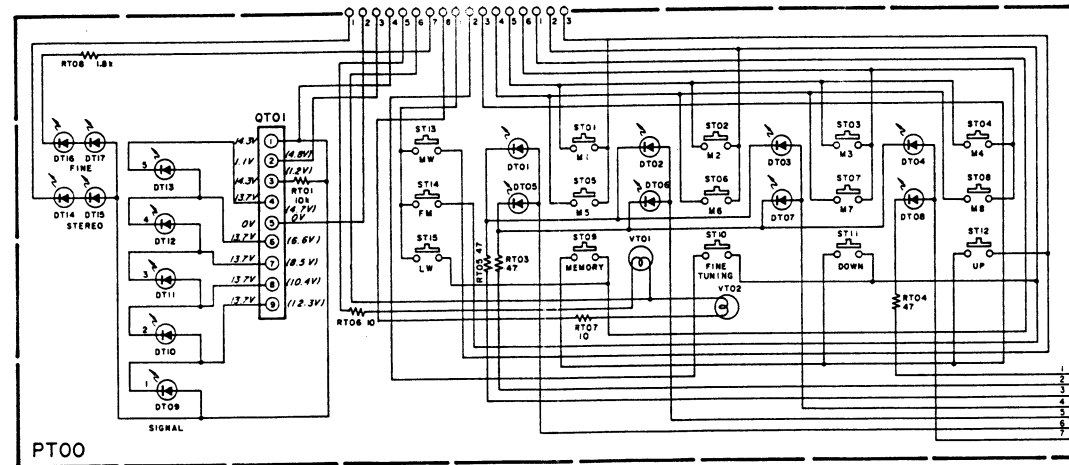

8.2 Display Assembly (P900) Schematic Diagram and Component Locations (Model ST-64)

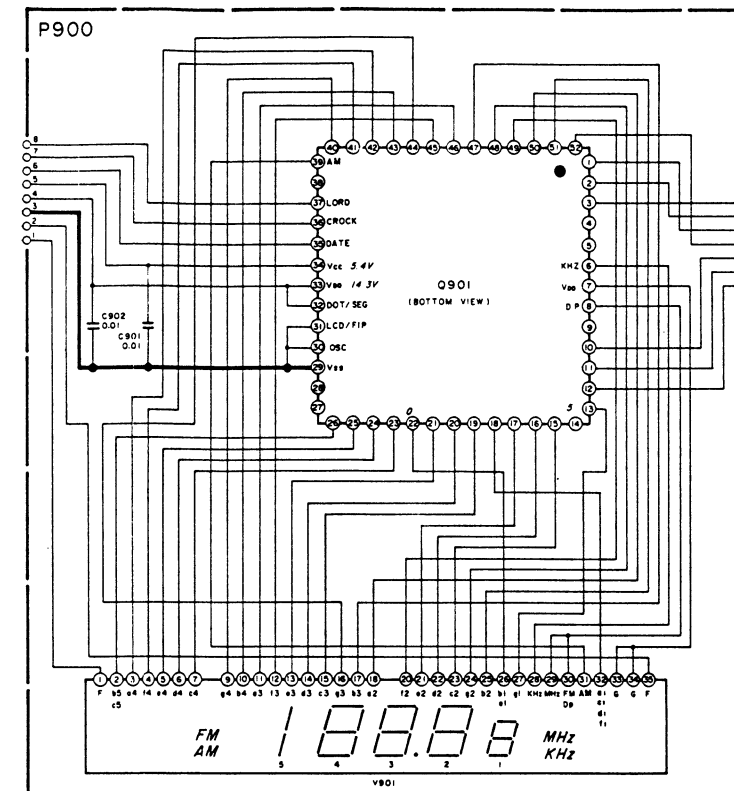

(Model ST-64L)

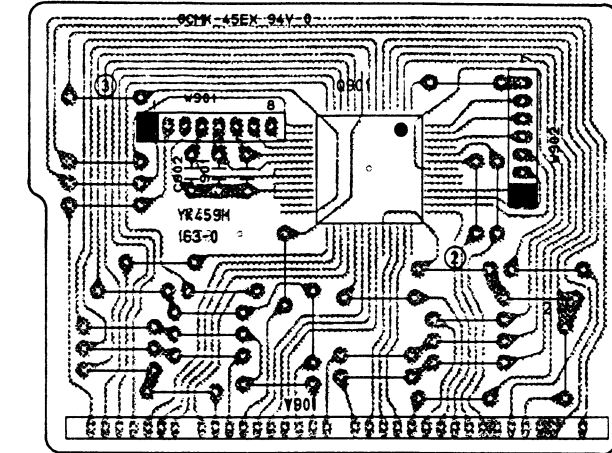
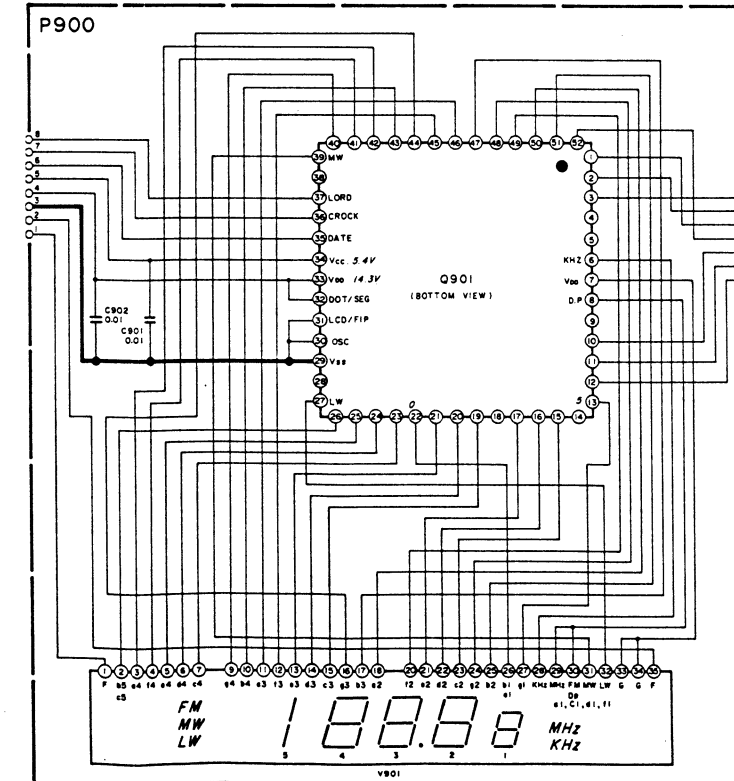

8.3 Mode Lamp Assembly (PR00) Schematic Diagram and Component Locations



8.4 Power/Mode Assembly (PS00) Schematic Diagram and Component Locations

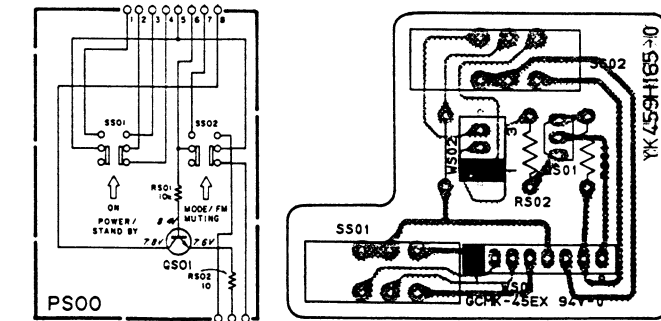

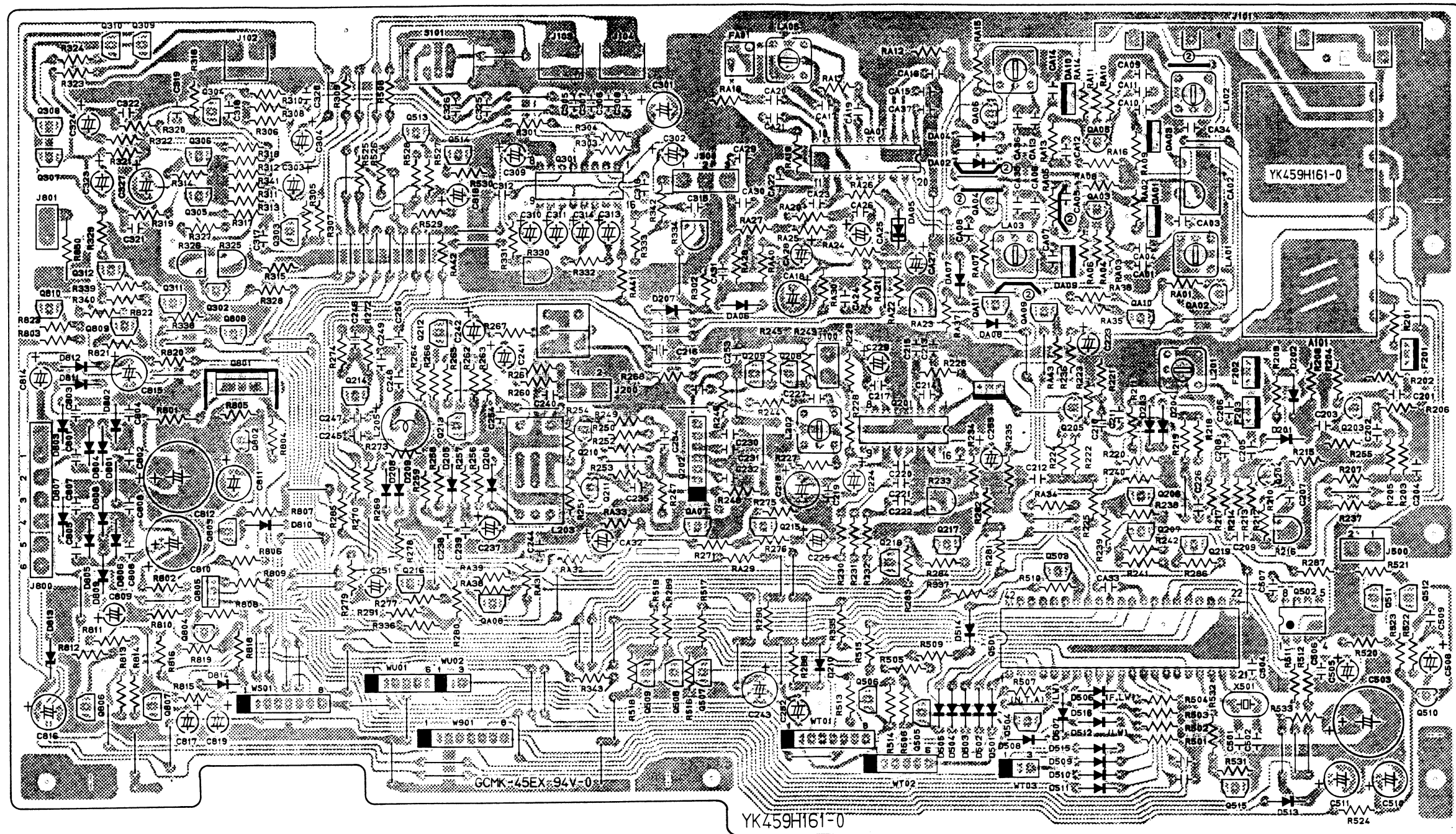

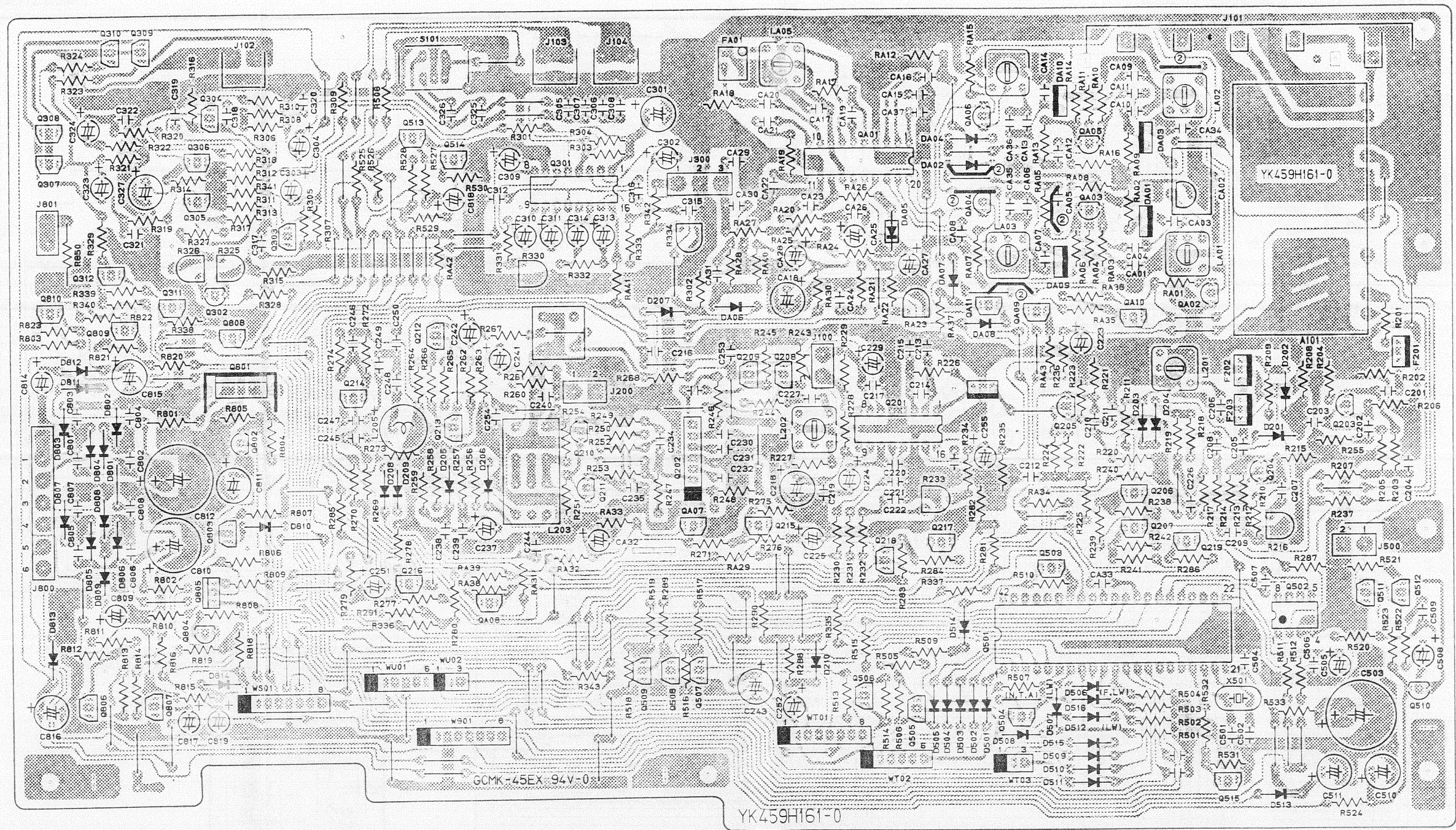

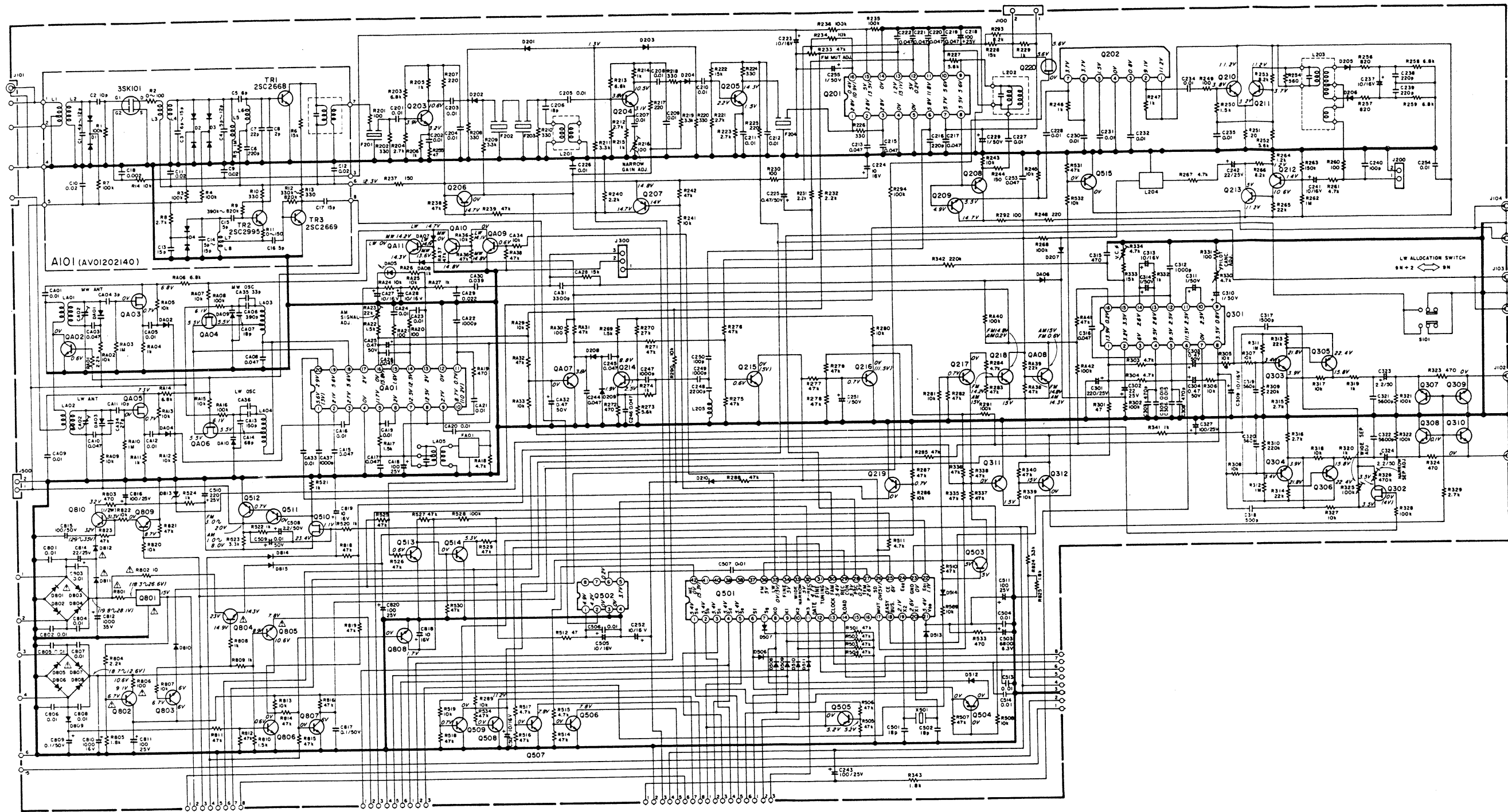

9. EXPLODED VIEW AND PARTS LIST

● [P01-99] Front Panel and Chassis

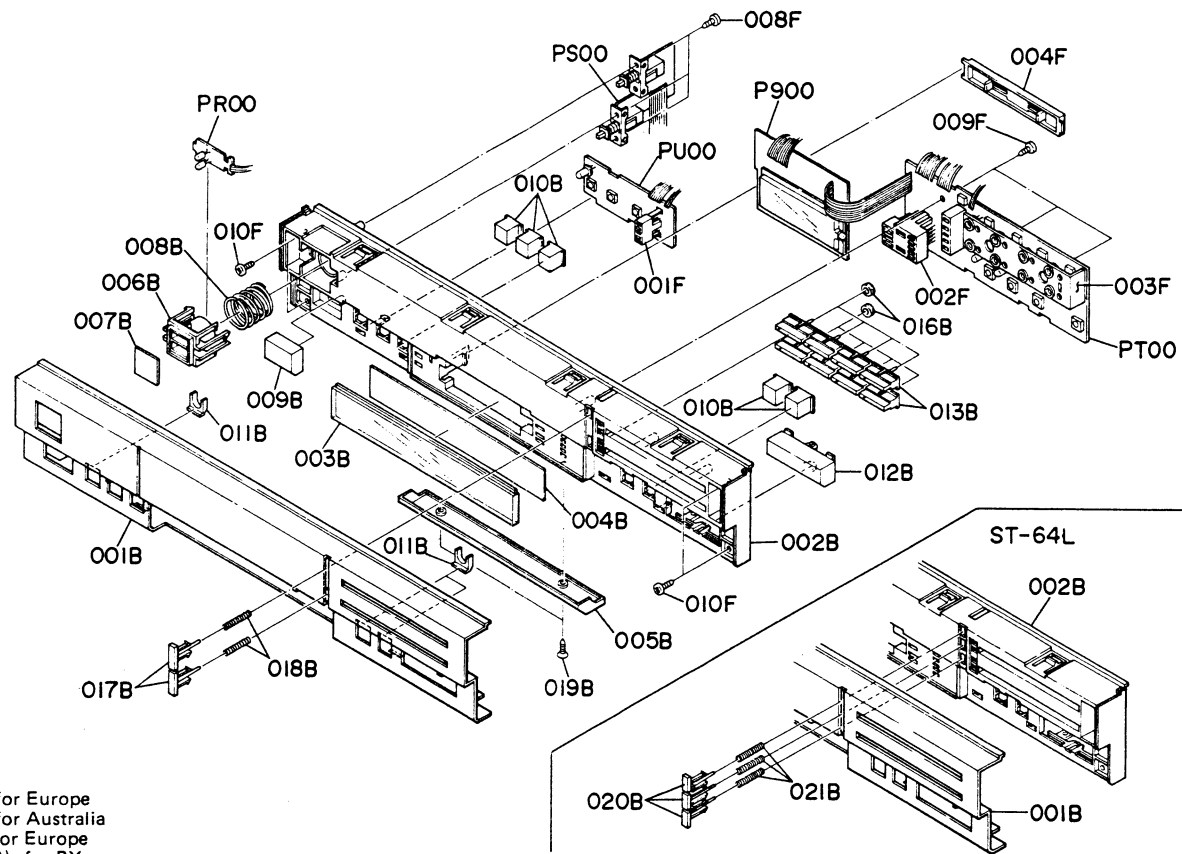

●(N): for Europe
 ●(A): for Australia
 ●(E): for Europe
 ●(P/PG): for PX
 ●(F): for Japan

REF.	Q'TY				PART NO.	DESCRIPTION
	N	A	E	P/PG		
001B	1	1	1	1	459H248010	Panel, Front; Gold (ST-64)
001B	1		1		459H248110	Panel, Front; Black (ST-64)
001B	1				460H248010	Panel, Front; Gold (ST-64L)
001B	1				460H248110	Panel, Front; Black (ST-64L)
001B	1			1	459H248120	Panel, Front; Black
002B	1	1	1	1	459H105010	Chassis, Front; Gold (ST-64)
002B	1		1		459H105110	Chassis, Front; Black (ST-64)
002B	1				460H105010	Chassis, Front; Gold (ST-64L)
002B	1				460H105110	Chassis, Front; Black (ST-64L)
003B	1	1	1	1	459H158010	Window
004B	1	1	1	1	459H303010	Mask, Digitron
005B	1	1	1	1	459H053010	Cover, Gold
005B	1		1		459H053110	Cover, Black
006B	1	1	1	1	459H270010	Button, Mode; Gold
006B	1		1		459H270110	Button, Mode; Black
007B	1	1	1	1	459H151010	Introducer, Mode; Gold
007B	1		1		459H151110	Introducer, Mode; Black
008B	1	1	1	1	444H115110	Spring, Mode Switch
009B	1	1	1	1	242H270010	Button, Power; Gold
009B	1		1		242H270110	Button, Power; Black

REF.	Q'TY				PART NO.	DESCRIPTION
	N	A	E	P/PG		
010B	5	5	5	5	448H270010	Button, Gold
010B	5		5		448H270110	Button, Black
011B	3	3	3	3	459H355010	Lens
012B	1	1	1	1	459H270020	Button, Tuning; Gold
012B	1		1		459H270120	Button, Tuning; Black
013B	8	8	8	8	459H270510	Button Assembly, Preset; Gold
013B	8		8		459H270530	Button Assembly, Preset; Black
016B	8	8	8	8	459H056010	Buffer, Preset Button
017B	2	2	2	2	459H270040	Button, FM/AM
018B	2	2	2	2	459H115010	Spring, FM/AM Button
019B	2	2	2	2	51500310B0	F.H. Taptite Screw F3 x 10
019B	2		2		51500310U0	F.H. Taptite Screw F3 x 10
020B	3				460H270010	Button, MW/LW; Gold (ST-64L)
020B	3				460H270010	Button, MW/LW; Black (ST-64L)
021B	3				460H115010	Spring (ST-64L)
001F	1	1	1	1	459H271010	Holder, LED
002F	1	1	1	1	459H271020	Holder, LED
003F	1	1	1	1	459H271030	Holder, LED
004F	1	1	1	1	431H258010	Hook, Digitron
008F	2	2	2	2	51280308B0	B.H. Tapped Screw B3 x 8
009F	3	3	3	3	51280308B0	B.H. Tapped Screw B3 x 8
010F	4	4	4	4	51280308B0	B.H. Tapped Screw B3 x 8

● [P03-99] Top Cover and Packing Materials

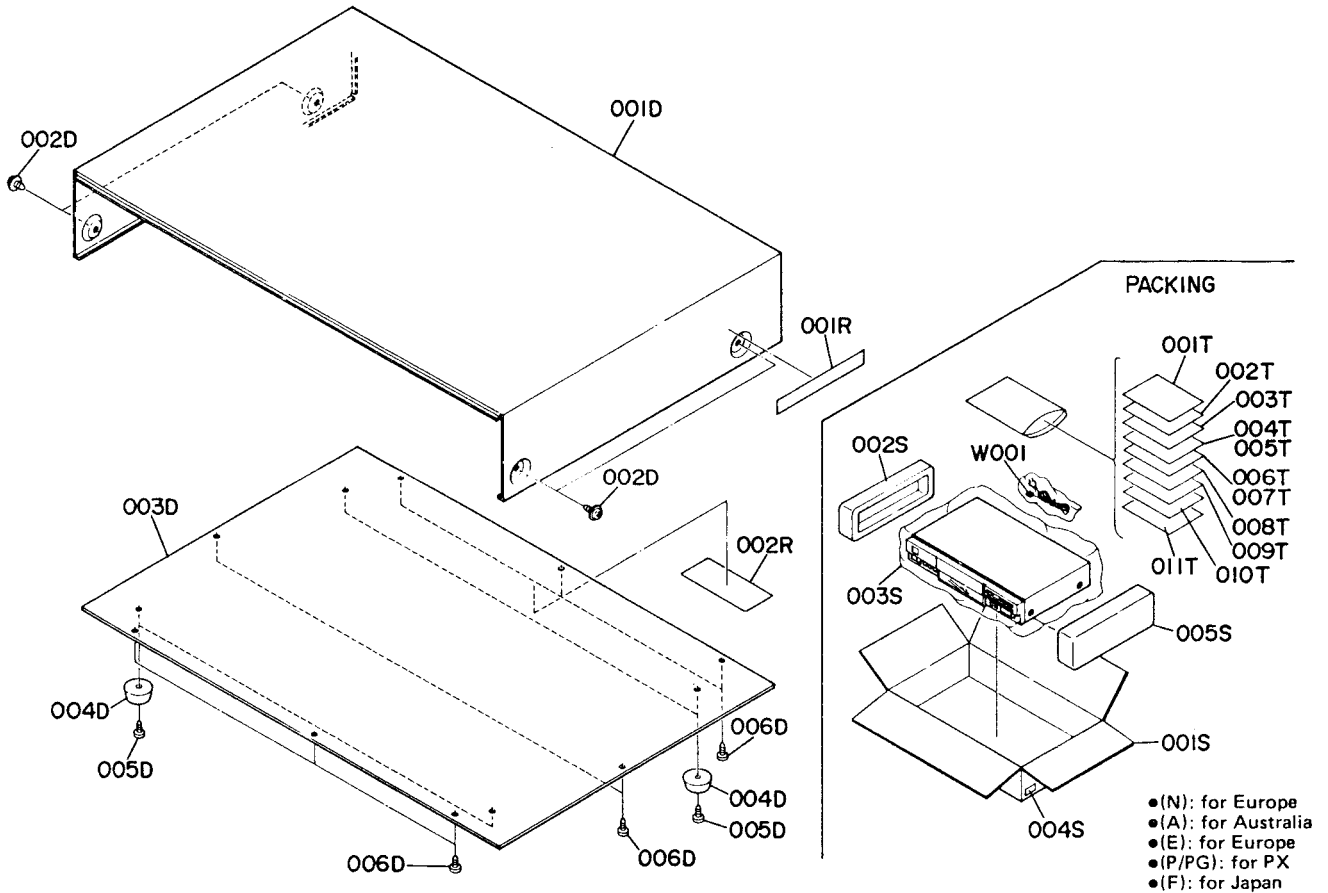

- (N): for Europe
- (A): for Australia
- (E): for Europe
- (P/PG): for PX
- (F): for Japan

REF. DESIG.	Q'TY				PART NO.	DESCRIPTION
	N	A	E	F		
001D	1	1	1	1	228H257210	Lid, Top Cover; Gold
001D	1	1	1	1	228H257310	Lid, Top Cover; Black
002D	4	4	4	4	51260408U0	B.T. Screw B4 x 8
003D	1	1	1	1	459H257010	Lid, Bottom Cover
004D	4	4	4	4	415H057010	Leg
005D	4	4	4	4	51570408B0	P. Taptite Screw P4 x 8
006D	8	8	8	8	51280308B0	B.H. Tapped Screw B3 x 8
001R	1	1	1	1	2911861020	Label, Top Cover
002R	1	1	1	1	2911861110	Label, Bottom Cover

REF. DESIG.	Q'TY				PART NO.	DESCRIPTION
	N	A	E	F		
001S	1	1		1	459H801020	Packing Case
001S			1	1	459H801010	Packing Case
001S	1				460H801010	Packing Case (ST-64L)
002S	1	1	1	1	459H809010	Cushion
003S	1	1	1	1	9090808030	Polyethylene Sheet
004S	4		4		9526019060	Serial No. Card
004S		4			9526019030	Serial No. Card
004S			3		9526019050	Serial No. Card
004S			4		9526019040	Serial No. Card
005S	1	1	1	1	459H809020	Cushion
001T	1	1	1	1	459H851310	User Manual
002T	1	1	1	1	459H851320	User Manual Spec
003T	1		1		459H856010	Circuit Diagram (ST-64)
003T	1				460H856010	Circuit Diagram (ST-64L)
004T		1			9631000090	Warranty Card
005T			1		416H854010	Warranty Card
006T			1		3435851210	User Manual
007T			1		459H851110	User Manual
008T	1				9631000130	Warranty Card
009T	1				128T854010	Warranty Card
010T			1		9611000050	User's Card
011T			1		9540000010	License
△W001	1				ZC01805010	A.C. Power Cord
△W001		1			ZC02006020	A.C. Power Cord

10. ELECTRICAL PARTS LIST

- (N): for Europe
- (A): for Australia
- (E): for Europe
- (P/PG): for PX
- (F): for Japan

REF. DESIG.	Q'TY					PART NO.	DESCRIPTION
	N	A	E	P/PG	F		
P100	1	1	1	1	1	YK459H1610	P100-TUNER P.W. Board, Tuner
	1	1				ZZ459H8610	P.W. Board Assembly (ST-64)
			1	1		ZZ459H7610	P.W. Board Assembly (ST-64)
	1					ZZ460H8610	P.W. Board Assembly(ST-64L)
P100-CAPACITORS							
CA01	1	1	1	1	1	DK18103310	Ceramic 0.01μF
CA02	1	1	1	1	1	CT12000090	Trimming 16pF (ST-64)
CA02	1					CT21400010	Trimming 14pFx2(ST-64L)
CA03	1	1	1	1	1	DF15473310	Film 0.047μF ±5%
CA04	1	1	1	1	1	DD10030370	Ceramic 3pF ±0.25pF
CA05	1	1	1	1	1	DK18103310	Ceramic 0.01μF (ST-64L)
CA06	1	1	1	1	1	DF15391550	Film 390pF ±5%
CA07	1	1	1	1	1	DD15180370	Ceramic 18pF ±5%
CA08	1	1	1	1	1	DK18473310	Ceramic 0.047μF
CA09	1					DK18103310	Ceramic 0.01μF (ST-64L)
CA10	1					DF15473310	Film 0.047μF ±5% (ST-64L)
CA11	1					DD11100370	Ceramic 10pF ±0.5pF (ST-64L)
CA12	1					DK18103310	Ceramic 0.01μF (ST-64L)
CA13	1					DD15151300	Ceramic 150pF ±5% (ST-64L)
CA15	1	1	1	1	1	DK18473310	Ceramic 0.047μF
CA16	1	1	1	1	1	DK18103310	Ceramic 0.01μF
CA17	1	1	1	1	1	DK18473310	Ceramic 0.047μF
CA18	1	1	1	1	1	EA10702510	Elect 100μF 25V
CA19	1	1	1	1	1	DK18103310	Ceramic 0.01μF
CA20	1	1	1	1	1	DK18103310	Ceramic 0.01μF
CA21	1	1	1	1	1	DK18103310	Ceramic 0.01μF
CA22	1	1	1	1	1	DK18102300	Ceramic 1000pF
CA23	1	1	1	1	1	DK18103310	Ceramic 0.01μF
CA24	1	1	1	1	1	DK18103310	Ceramic 0.01μF
CA25	1	1	1	1	1	EA47405010	Elect 0.47μF 50V
CA26	1	1	1	1	1	DK18473310	Ceramic 0.047μF
CA27	1	1	1	1	1	EA10601610	Elect 10μF 16V
CA28	1	1	1	1	1	EA10601610	Elect 10μF 16V
CA29	1	1	1	1	1	DF15223310	Film 0.022μF ±5%
CA30	1	1	1	1	1	DF15393310	Film 0.039μF ±5%
CA31	1	1	1	1	1	DF15332310	Film 3300pF ±5%
CA32	1	1	1	1	1	EA47405010	Elect 0.47μF 50V
CA33	1	1	1	1	1	DK18103310	Ceramic 0.01μF
CA34	1					DD15270370	Ceramic 27pF ±5% (ST-64L)
CA35	1	1	1	1	1	DD15330300	Ceramic 33pF ±5%
CA37	1	1	1	1	1	DK18102300	Ceramic 1000pF
C201	1	1	1	1	1	DK18103310	Ceramic 0.01μF
C202	1	1	1	1	1	DK18103310	Ceramic 0.01μF
C203	1	1	1	1	1	DK18103310	Ceramic 0.01μF
C204	1	1	1	1	1	DK18103310	Ceramic 0.01μF
C205	1	1	1	1	1	DK18103310	Ceramic 0.01μF
C206	1	1	1	1	1	DD15180370	Ceramic 18pF ±5%
C207	1	1	1	1	1	DK18103310	Ceramic 0.01μF
C208	1	1	1	1	1	DK18103310	Ceramic 0.01μF
C209	1	1	1	1	1	DK18103310	Ceramic 0.01μF
C210	1	1	1	1	1	DK18103310	Ceramic 0.01μF

REF. DESIG.	Q'TY					PART NO.	DESCRIPTION
	N	A	E	P/PG	F		
C211	1	1	1	1	1	DK18103310	Ceramic 0.01μF
C212	1	1	1	1	1	DK18103310	Ceramic 0.01μF
C213	1	1	1	1	1	DK18473310	Ceramic 0.047μF
C214	1	1	1	1	1	DK18473310	Ceramic 0.047μF
C215	1	1	1	1	1	DK18473310	Ceramic 0.047μF
C216	1	1	1	1	1	DD15221370	Ceramic 220pF ±5%
C217	1	1	1	1	1	DK18473310	Ceramic 0.047μF
C218	1	1	1	1	1	EA10701610	Elect 100μF 16V
C219	1	1	1	1	1	DK18473310	Ceramic 0.047μF
C220	1	1	1	1	1	DK18473310	Ceramic 0.047μF
C221	1	1	1	1	1	DK18473310	Ceramic 0.047μF
C222	1	1	1	1	1	DK18473310	Ceramic 0.047μF
C223	1	1	1	1	1	EA47505010	Elect 47μF 50V
C224	1	1	1	1	1	EA10602510	Elect 10μF 25V
C225	1	1	1	1	1	EA47405010	Elect 0.47μF 50V
C226	1	1	1	1	1	DK18103310	Ceramic 0.01μF
C227	1	1	1	1	1	DK18103310	Ceramic 0.01μF
C228	1	1	1	1	1	DK18103310	Ceramic 0.01μF
C229	1	1	1	1	1	EA10505010	Elect 1μF 50V
C230	1	1	1	1	1	DK18103310	Ceramic 0.01μF
C231	1	1	1	1	1	DK18103310	Ceramic 0.01μF
C232	1	1	1	1	1	DK18103310	Ceramic 0.01μF
C234	1	1	1	1	1	DK18103310	Ceramic 0.01μF
C235	1	1	1	1	1	DK18103310	Ceramic 0.01μF
C237	1	1	1	1	1	EA10601610	Elect 10μF 16V
C238	1	1	1	1	1	DD15221370	Ceramic 220pF ±5%
C239	1	1	1	1	1	DD15221370	Ceramic 220pF ±5%
C240	1	1	1	1	1	DD15101370	Ceramic 100pF ±5%
C241	1	1	1	1	1	EA10601610	Elect 10μF 16V
C242	1	1	1	1	1	EA22602510	Elect 22μF 25V
C243	1	1	1	1	1	EA10702510	Elect 100μF 25V
C244	1	1	1	1	1	DK18473310	Ceramic 0.047μF
C245	1	1	1	1	1	DK18473310	Ceramic 0.047μF
C246	1	1	1	1	1	DK18473310	Ceramic 0.047μF
C247	1	1	1	1	1	DK18102300	Ceramic 100pF
C248	1	1	1	1	1	DK18222300	Ceramic 2200pF
C249	1	1	1	1	1	DK18102300	Ceramic 1000pF
C250	1	1	1	1	1	DD15101370	Ceramic 100pF ±5%
C251	1	1	1	1	1	EA10505010	Elect 1μF 50V
C252	1	1	1	1	1	EA10602510	Elect 10μF 25V
C253	1	1	1	1	1	DK18473310	Ceramic 0.047μF
C254	1	1	1	1	1	DK18103310	Ceramic 0.01μF
C255	1	1	1	1	1	EA10505010	Elect 1μF 50V (ST-64)
C301	1	1	1	1	1	EA22702510	Elect 220μF 25V
C302	1	1	1	1	1	EA22602510	Elect 22μF 25V
C303	1	1	1	1	1	EA47405010	Elect 0.47μF 50V
C304	1	1	1	1	1	EA47405010	Elect 0.47μF 50V
C305	1	1	1	1	1	DF15103310	Film 0.01μF ±5%
C306	1	1	1	1	1	DF15103310	Film 0.01μF ±5%
C307	1	1	1	1	1	DF15471350	Film 470pF ±5%
C308	1	1	1	1	1	DF15471350	Film 470pF ±5%
C309	1	1	1	1	1	EA10605010	Elect 10μF 50V
C310	1	1	1	1	1	EA10605010	Elect 10μF 50V
C311	1	1	1	1	1	EA10605010	Elect 10μF 50V
C312	1	1	1	1	1	DK16102300	Ceramic 1000pF ±10%
C313	1	1	1	1	1	EA10601610	Elect 10μF 16V
C314	1	1	1	1	1	EA10505010	Elect 1μF 50V
C315	1	1	1	1	1	DF15471550	Film 470pF ±5%
C316	1	1	1	1	1	DF15473310	Film 0.047μF ±5%

- (N): for Europe
- (A): for Australia
- (E): for Europe
- (P/PG): for PX
- (F): for Japan

REF. DESIG.	Q'TY					PART NO.	DESCRIPTION
	N	A	E	P/PG	F		
C317	1	1	1	1	1	DF15152310	Film 1500pF ±5%
C318	1	1	1	1	1	DF15152310	Film 1500pF ±5%
C319	1	1	1	1	1	DD15561370	Ceramic 560pF ±5%
C320	1	1	1	1	1	DD15561370	Ceramic 560pF ±5%
C321	1	1	1	1	1	DF15562310	Film 5600pF ±5%
C322	1	1	1	1	1	DF15562310	Film 5600pF ±5%
C323	1	1	1	1	1	EA22505010	Elect 2.2μF 50V
C324	1	1	1	1	1	EA22505010	Elect 2.2μF 50V
C325			1	1		DF15562310	Film 5600pF ±5% (ST-64)
C326			1	1		DF15562310	Film 5600pF ±5% (ST-64)
C327	1	1	1	1	1	EA10702510	Elect 100μF 25V
C501	1	1	1	1	1	DD15180300	Ceramic 18pF ±5%
C502	1	1	1	1	1	DD15180300	Ceramic 18pF ±5%
C503	1	1	1	1	1	EA68800610	Elect 6800pF 6.3V
C504	1	1	1	1	1	DK18103310	Ceramic 0.01μF
C505	1	1	1	1	1	EA10601610	Elect 10μF 16V
C506	1	1	1	1	1	DK18103310	Ceramic 0.01μF
C507	1	1	1	1	1	DK18103310	Ceramic 0.01μF
C508	1	1	1	1	1	EA22505010	Elect 2.2μF 50V
C509	1	1	1	1	1	DF15104310	Film 0.1μF ±5%
C510	1	1	1	1	1	EA22702510	Elect 220μF 25V
C511	1	1	1	1	1	EA10702510	Elect 100μF 25V
C512	1	1	1	1	1	EA10601610	Elect 10μF 16V
C513	1	1	1	1	1	DK18103310	Ceramic 0.01μF
C514	1	1	1	1	1	DK18103310	Ceramic 0.01μF
C801	1	1	1	1	1	DK18103310	Ceramic 0.01μF
C802	1	1	1	1	1	DK18103310	Ceramic 0.01μF
C803	1	1	1	1	1	DK18103310	Ceramic 0.01μF
C804	1	1	1	1	1	DK18103310	Ceramic 0.01μF
C805	1	1	1	1	1	DK18103310	Ceramic 0.01μF
C806	1	1	1	1	1	DK18103310	Ceramic 0.01μF
C807	1	1	1	1	1	DK18103310	Ceramic 0.01μF
C808	1	1	1	1	1	DK18103310	Ceramic 0.01μF
C809	1	1	1	1	1	EA10405010	Elect 0.1μF 50V
C810	1	1	1	1	1	EA10801610	Elect 1000μF 16V
C811	1	1	1	1	1	EA10702510	Elect 100μF 25V
C812	1	1	1	1	1	EA10803510	Elect 1000μF 35V
C814	1	1	1	1	1	EA22602510	Elect 22μF 25V
C815	1	1	1	1	1	EA10705010	Elect 100μF 50V
C816	1	1	1	1	1	EA10702510	Elect 100μF 25V
C817	1	1	1	1	1	EA10405010	Elect 0.1μF 50V
C818	1	1	1	1	1	EA10602510	Elect 10μF 25V
C819	1	1	1	1	1	EA10601610	Elect 10μF 16V
C820	1	1	1	1	1	EA10702510	Elect 100μF 25V
RA01	1					GD05222140	2.2kΩ (ST-64L)
RA02	1	1	1	1	1	GD05103140	10kΩ
RA03	1	1	1	1	1	GD05105140	1MΩ
RA04	1	1	1	1	1	GD05102140	1kΩ
RA05	1					GD05103140	10kΩ (ST-64L)
RA06	1	1	1	1	1	GD05682140	6.8kΩ
RA07	1					GD05103140	10kΩ (ST-64L)
RA08	1	1	1	1	1	GD05104140	100kΩ
RA09	1					GD05103140	10kΩ (ST-64L)
RA10	1					GD05105140	1MΩ (ST-64L)

P100-RESISTORS
(All Resistors are ±5% & ¼W)

REF. DESIG.	Q'TY					PART NO.	DESCRIPTION
	N	A	E	P/PG	F		
RA11	1					GD05102140	1KΩ (ST-64L)
RA12	1					GD05103140	10KΩ (ST-64L)
RA13	1					GD05103140	10KΩ (ST-64L)
RA14	1					GD05682140	6.8KΩ (ST-64L)
RA15	1					GD05103140	10KΩ (ST-64L)
RA16	1					GD05104140	100KΩ (ST-64L)
RA17	1	1	1	1	1	GD05152140	1.5KΩ
RA18	1	1	1	1	1	GD05472140	4.7KΩ
RA19	1	1	1	1	1	GD05471140	470Ω
RA20	1	1	1	1	1	GD05101140	100Ω
RA21	1	1	1	1	1	GD05101140	100Ω
RA22	1	1	1	1	1	GD05152140	1.5KΩ
RA23	1	1	1	1	1	RA02230600	22KΩ, Trimming
RA24	1	1	1	1	1	GD05103140	10KΩ
RA25	1	1	1	1	1	GD05103140	10KΩ
RA26	1	1	1	1	1	GD05102140	1KΩ
RA27	1	1	1	1	1	GD05102140	1KΩ
RA28	1	1	1	1	1	GD05153140	15KΩ
RA29	1	1	1	1	1	GD05103140	10KΩ
RA30	1	1	1	1	1	GD05101140	100Ω
RA31	1	1	1	1	1	GD05473140	47KΩ
RA32	1	1	1	1	1	GD05103140	10KΩ
RA33	1	1	1	1	1	GD05103140	10KΩ
RA34	1					GD05103140	10KΩ (ST-64L)
RA35	1					GD05103140	10KΩ (ST-64L)
RA36	1					GD05473140	47KΩ (ST-64L)
RA37	1					GD05473140	47KΩ (ST-64L)
RA38	1	1	1	1	1	GD05473140	47KΩ
RA39	1	1	1	1	1	GD05223140	22KΩ
RA40	1	1	1	1	1	GD05104140	100KΩ
RA41	1	1	1	1	1	GD05473140	47KΩ
RA42	1	1	1	1	1	GD05104140	100KΩ
R201	1	1	1	1	1	GD05101140	100Ω
R202	1	1	1	1	1	GD05331140	330Ω
R203	1	1	1	1	1	GD05682140	6.8KΩ
R204	1	1	1	1	1	GD05272140	2.7KΩ
R205	1	1	1	1	1	GD05102140	1KΩ
R206	1	1	1	1	1	GD05102140	1KΩ
R207	1	1	1	1	1	GD05221140	220Ω
R208	1	1	1	1	1	GD05331140	330Ω
R209	1	1	1	1	1	GD05332140	3.3KΩ
R210	1	1	1	1	1	GD05331140	330Ω
R211	1	1	1	1	1	GD05332140	3.3KΩ
R212	1	1	1	1	1	GD05272140	2.7KΩ
R213	1	1	1	1	1	GD05682140	6.8KΩ
R214	1	1	1	1	1	GD05102140	1KΩ
R215	1	1	1	1	1	GD05102140	1KΩ
R216	1	1	1	1	1	RA01010600	100Ω, Trimming
R217	1	1	1	1	1	GD05221140	220Ω
R218	1	1	1	1	1	GD05331140	330Ω
R219	1	1	1	1	1	GD05332140	3.3KΩ
R220	1	1	1	1	1	GD05331140	330Ω
R221	1	1	1	1	1	GD05272140	2.7KΩ
R222	1	1	1	1	1	GD05153140	15KΩ
R223	1	1	1	1	1	GD05272140	2.7KΩ
R224	1	1	1	1	1	GD05331140	330Ω
R225	1	1	1	1	1	GD05221140	220Ω
R226	1	1	1	1	1	GD05331140	330Ω
R227	1	1	1	1	1	GD05562140	5.6KΩ
R228	1	1	1	1	1	GD05153140	15KΩ
R229	1	1	1	1	1	GD05102140	1KΩ
R230	1	1	1	1	1	GD05101140	100Ω

- (N): for Europe
- (A): for Australia
- (E): for Europe
- (P/PG): for PX
- (F): for Japan

REF. DESIG.	Q'TY					PART NO.	DESCRIPTION
	N	A	E	P/PG	F		
R231	1	1	1	1	1	GD05222140	2.2K Ω
R232	1	1	1	1	1	GD05222140	2.2K Ω
R233	1	1	1	1	1	RA04730600	47K Ω , Trimming
R234	1	1	1	1	1	GD05103140	10K Ω
R235	1	1	1	1	1	GD05104140	100K Ω
R236	1	1	1	1	1	GD05104140	100K Ω
R237	1	1	1	1	1	GD05151140	150 Ω
R238	1	1	1	1	1	GD05473140	47K Ω
R239	1	1	1	1	1	GD05473140	47K Ω
R240	1	1	1	1	1	GD05222140	2.2K Ω
R241	1	1	1	1	1	GD05103140	10K Ω
R242	1	1	1	1	1	GD05473140	47K Ω
R243	1	1	1	1	1	GD05103140	10K Ω
R244	1	1	1	1	1	GD05151140	150 Ω
R245	1	1	1	1	1	GD05103140	10K Ω
R246	1	1	1	1	1	GD05102140	1K Ω
R247	1	1	1	1	1	GD05102140	1K Ω
R248	1	1	1	1	1	GD05221140	220 Ω
R249	1	1	1	1	1	GD05101140	100 Ω
R250	1	1	1	1	1	GD05152140	1.5K Ω
R251	1	1	1	1	1	GD05121140	120 Ω
R252	1	1	1	1	1	GD05562140	5.6K Ω
R253	1	1	1	1	1	GD05822140	8.2K Ω
R254	1	1	1	1	1	GD05561140	560 Ω
R255	1	1	1	1	1	GD05470140	47 Ω
R256	1	1	1	1	1	GD05821140	820 Ω
R257	1	1	1	1	1	GD05821140	820 Ω
R258	1	1	1	1	1	GD05682140	6.8K Ω
R259	1	1	1	1	1	GD05682140	6.8K Ω
R260	1	1	1	1	1	GD05101140	100 Ω
R261	1	1	1	1	1	GD05472140	4.7K Ω
R262	1	1	1	1	1	GD05105140	1M Ω
R263	1	1	1	1	1	GD05154140	150K Ω
R264	1	1	1	1	1	GD05122140	1.2K Ω
R265	1	1	1	1	1	GD05223140	22K Ω
R266	1	1	1	1	1	GD05822140	8.2K Ω
R267	1	1	1	1	1	GD05472140	4.7K Ω
R268	1	1	1	1	1	GD05104140	100K Ω
R269	1	1	1	1	1	GD05152140	1.5K Ω
R270	1	1	1	1	1	GD05273140	27K Ω
R271	1	1	1	1	1	GD05473140	47K Ω
R272	1	1	1	1	1	GD05471140	470 Ω
R273	1	1	1	1	1	GD05562140	5.6K Ω
R274	1	1	1	1	1	GD05102140	1K Ω
R275	1	1	1	1	1	GD05473140	47K Ω
R276	1	1	1	1	1	GD05473140	47K Ω
R277	1	1	1	1	1	GD05473140	47K Ω
R278	1	1	1	1	1	GD05473140	47K Ω
R279	1	1	1	1	1	GD05473140	47K Ω
R280	1	1	1	1	1	GD05103140	10K Ω
R281	1	1	1	1	1	GD05103140	10K Ω
R282	1	1	1	1	1	GD05473140	47K Ω
R283	1	1	1	1	1	GD05473140	47K Ω
R284	1	1	1	1	1	GD05472140	4.7K Ω
R285	1	1	1	1	1	GD05473140	47K Ω
R286	1	1	1	1	1	GD05103140	10K Ω
R287	1	1	1	1	1	GD05473140	47K Ω
R288	1	1	1	1	1	GD05473140	47K Ω
R289	1	1	1	1	1	GD05103140	10K Ω
R290	1	1	1	1	1	GD05103140	10K Ω
R291	1	1	1	1	1	GD05104140	100K Ω (ST-64)
R292	1	1	1	1	1	GD05101140	100 Ω
R293	1	1	1	1	1	GD05822140	8.2K Ω
R294	1	1	1	1	1	GD05104140	100K Ω

REF. DESIG.	Q'TY					PART NO.	DESCRIPTION
	N	A	E	P/PG	F		
R301	1	1	1	1	1	GG05470140	47 Ω
R302	1	1	1	1	1	GD05104140	100K Ω
R303	1	1	1	1	1	GD05472140	4.7K Ω
R304	1	1	1	1	1	GD05472140	4.7K Ω
R305	1	1	1	1	1	GD05103140	10K Ω
R306	1	1	1	1	1	GD05103140	10K Ω
R307	1	1	1	1	1	GD05103140	10K Ω
R308	1	1	1	1	1	GD05103140	10K Ω
R309	1	1	1	1	1	GD05224140	220K Ω
R310	1	1	1	1	1	GD05224140	220K Ω
R311	1	1	1	1	1	GD05105140	1M Ω
R312	1	1	1	1	1	GD05105140	1M Ω
R313	1	1	1	1	1	GD05223140	22K Ω
R314	1	1	1	1	1	GD05223140	22K Ω
R315	1	1	1	1	1	GD05272140	2.7K Ω
R316	1	1	1	1	1	GD05272140	2.7K Ω
R317	1	1	1	1	1	GD05103140	10K Ω
R318	1	1	1	1	1	GD05103140	10K Ω
R319	1	1	1	1	1	GD05102140	1K Ω
R320	1	1	1	1	1	GD05102140	1K Ω
R321	1	1	1	1	1	GD05104140	100K Ω
R322	1	1	1	1	1	GD05104140	100K Ω
R323	1	1	1	1	1	GD05471140	470 Ω
R324	1	1	1	1	1	GD05471140	470 Ω
R325	1	1	1	1	1	RA01040600	100K Ω , Trimming
R326	1	1	1	1	1	RA02240600	220K Ω , Trimming
R327	1	1	1	1	1	GD05103140	10K Ω
R328	1	1	1	1	1	GD05104140	100K Ω
R329	1	1	1	1	1	GD05272140	2.7K Ω
R330	1	1	1	1	1	RA04720600	4.7K Ω , Trimming
R331	1	1	1	1	1	GD05101140	100 Ω
R332	1	1	1	1	1	GD05102140	1K Ω
R333	1	1	1	1	1	GD05153140	15K Ω
R334	1	1	1	1	1	RA04720600	4.7K Ω , Trimming
R335	1	1	1	1	1	GD05473140	47K Ω
R336	1	1	1	1	1	GD05473140	47K Ω
R337	1	1	1	1	1	GD05473140	47K Ω
R338	1	1	1	1	1	GD05473140	47K Ω
R339	1	1	1	1	1	GD05103140	10K Ω
R340	1	1	1	1	1	GD05473140	47K Ω
R341	1	1	1	1	1	GD05102140	1K Ω
R342	1	1	1	1	1	GD05224140	220K Ω
R343	1	1	1	1	1	GD05182140	1.8K Ω
R501	1	1	1	1	1	GD05473140	47K Ω
R502	1	1	1	1	1	GD05473140	47K Ω
R503	1	1	1	1	1	GD05473140	47K Ω
R504	1	1	1	1	1	GD05473140	47K Ω
R505	1	1	1	1	1	GD05103140	10K Ω
R506	1	1	1	1	1	GD05473140	47K Ω
R507	1	1	1	1	1	GD05473140	47K Ω (ST-64)
R507	1	1	1	1	1	GD05473140	47K Ω (ST-64L)
R508	1	1	1	1	1	GD05103140	10K Ω (ST-64)
R508	1	1	1	1	1	GD05103140	10K Ω (ST-64L)
R509	1	1	1	1	1	GD05103140	10K Ω
R510	1	1	1	1	1	GD05473140	47K Ω
R511	1	1	1	1	1	GD05472140	4.7K Ω
R512	1	1	1	1	1	GD05470140	47 Ω
R513	1	1	1	1	1	GD05182140	1.8K Ω
R514	1	1	1	1	1	GD05473140	47K Ω
R515	1	1	1	1	1	GD05472140	4.7K Ω
R516	1	1	1	1	1	GD05473140	47K Ω
R517	1	1	1	1	1	GD05472140	4.7K Ω
R518	1	1	1	1	1	GD05473140	47K Ω

- (N): for Europe
- (A): for Australia
- (E): for Europe
- (P/PG): for PX
- (F): for Japan

REF. DESIG.	Q'TY					PART NO.	DESCRIPTION
	N	A	E	P/PG	F		
R519	1	1	1	1	1	GD05103140	10KΩ
R520	1	1	1	1	1	GD05102140	1KΩ
R521	1	1	1	1	1	GD05102140	1KΩ
R522	1	1	1	1	1	GD05102140	1KΩ
R523	1	1	1	1	1	GD05332140	3.3KΩ
R524	1	1	1	1	1	GD05102140	1KΩ
R525	1	1	1	1	1	GD05473140	47KΩ
R526	1	1	1	1	1	GD05473140	47KΩ
R527	1	1	1	1	1	GD05473140	47KΩ
R528	1	1	1	1	1	GD05104140	100KΩ
R529	1	1	1	1	1	GD05473140	47KΩ
R530	1	1	1	1	1	GD05473140	47KΩ
R531	1	1	1	1	1	GD05473140	47KΩ
R532	1	1	1	1	1	GD05103140	10KΩ
R533	1	1	1	1	1	GD05471140	470Ω
R534	1	1	1	1	1	GD05473140	47KΩ
△R801	1	1	1	1	1	NH05100120	10Ω 1/4W, Fusible
△R802	1	1	1	1	1	NH05100140	10Ω, Fusible
R803	1	1	1	1	1	GG05471140	470Ω
R804	1	1	1	1	1	GD05222140	2.2KΩ
R805	1	1	1	1	1	GD05182140	1.8KΩ
△R806	1	1	1	1	1	GG05101140	100Ω
R807	1	1	1	1	1	GD05103140	10KΩ
R808	1	1	1	1	1	GD05102140	1KΩ
R809	1	1	1	1	1	GD05102140	1KΩ
R810	1	1	1	1	1	GD05152140	1.5KΩ
R811	1	1	1	1	1	GD05473140	47KΩ
R812	1	1	1	1	1	GD05473140	47KΩ
R813	1	1	1	1	1	GD05103140	10KΩ
R814	1	1	1	1	1	GD05473140	47KΩ
R815	1	1	1	1	1	GD05473140	47KΩ
R816	1	1	1	1	1	GD05473140	47KΩ
R818	1	1	1	1	1	GD05473140	47KΩ
R819	1	1	1	1	1	GD05473140	47KΩ
R820	1	1	1	1	1	GD05103140	10KΩ
R821	1	1	1	1	1	GD05473140	47KΩ
R822	1	1	1	1	1	GD05103140	10KΩ
R823	1	1	1	1	1	GD05473140	47KΩ
R824	1	1	1	1	1	GD05332140	3.3KΩ
R825	1	1	1	1	1	GD05182140	1.8KΩ
P100-SEMICONDUCTORS							
DA01	1	1	1	1	1	HD40006030	Varicap SVC321SP
DA02	1	1	1	1	1	HD20001000	Diode 1S1555 (ST-64L)
DA03	1	1	1	1	1	HD40006030	Varicap SVC321SP (ST-64L)
DA04	1	1	1	1	1	HD20001000	Diode 1S1555 (ST-64L)
DA05	1	1	1	1	1	H110044320	L.E.D. GL-9PR26
DA06	1	1	1	1	1	HD20001000	Diode 1S1555
DA07	1	1	1	1	1	HD20001000	Diode 1S1555 (ST-64L)
DA08	1	1	1	1	1	HD20001000	Diode 1S1555 (ST-64L)
DA09	1	1	1	1	1	HD40006030	Varicap SVC321SP
DA10	1	1	1	1	1	HD40006030	Varicap SVC321SP (ST-64L)
D201	10	10	10	10	10	HD20001000	Diode 1S1555
∫							
D210							

REF. DESIG.	Q'TY					PART NO.	DESCRIPTION
	N	A	E	P/PG	F		
D501							
∫	5	5	5	5	5	HD20001000	Diode 1S1555
D505							
D506					1	HD20001000	Diode 1S1555 (ST-64)
D507	1					HD20001000	Diode 1S1555 (ST-64L)
D508							
∫	4	4	4	4	4	HD20001000	Diode 1S1555
D511							
D512	1					HD20001000	Diode 1S1555 (ST-64L)
D513	1	1	1	1	1	HD20001000	Diode 1S1555 (ST-64)
D513	1					HD30015020	Zener MA1240(ST-64L)
D514	1	1	1	1	1	HD20001000	Diode 1S1555
D515			1	1		HD20001000	Diode 1S1555 (ST-64)
D516					1	HD20001000	Diode 1S1555 (ST-64)
△D801							
∫	9	9	9	9	9	HD20022030	Diode DSF10C
△D809							
D810	1	1	1	1	1	HD20001000	Diode 1S1555
△D811	1	1	1	1	1	HD20022030	Diode DSF10C
△D812	1	1	1	1	1	HD20022030	Diode DSF10C
D813	1	1	1	1	1	HD30015020	Zener MA1240
D814	1	1	1	1	1	HD20001000	Diode 1S1555
D815	1	1	1	1	1		Diode
QA01	1	1	1	1	1	HC10058030	IC LA1245
QA02	1	1	1	1	1	HT406551E0	Transistor 2SD655(E) (ST-64L)
QA03	1	1	1	1	1	HF200551D0	F.E.T. 2SK55D
QA04	1	1	1	1	1	HF200300B0	F.E.T. 2SK30A(Y) (ST-64L)
QA05	1	1	1	1	1	HF200551D0	F.E.T. 2SK55D(ST-64L)
QA06	1	1	1	1	1	HF200300B0	F.E.T. 2SK30A(Y) (ST-64L)
QA07	1	1	1	1	1	HT317402F0	Transistor 2SC1740S(R,S)
QA08	1	1	1	1	1	HT109332B0	Transistor 2SA933SP(R,S)
QA09	1	1	1	1	1	HT317402F0	Transistor 2SC1740S(R,S) (ST-64L)
QA10	1	1	1	1	1	HT109332B0	Transistor 2SA933SP(R,S) (ST-64L)
QA11	1	1	1	1	1	HT109332B0	Transistor 2SA933SP(R,S) (ST-64L)
Q201	1	1	1	1	1	HC10028030	IC LA1231
Q202	1	1	1	1	1	HC10017060	IC μPC1163H
Q203	1	1	1	1	1	HT310471C0	Transistor 2SC1047C
Q204	1	1	1	1	1	HT310471C0	Transistor 2SC1047C
Q205	1	1	1	1	1	HT310471C0	Transistor 2SC1047C
Q206	1	1	1	1	1	HT109332B0	Transistor 2SA933SP(R,S)
Q207	1	1	1	1	1	HT109332B0	Transistor 2SA933SP(R,S)
Q208	1	1	1	1	1	HT310471C0	Transistor 2SC1047C
Q209	1	1	1	1	1	HT310471C0	Transistor 2SC1047C
Q210	1	1	1	1	1	HT310471C0	Transistor 2SC1047C
Q211	1	1	1	1	1	HT310471C0	Transistor 2SC1047C
Q212	1	1	1	1	1	HT317402F0	Transistor 2SC1740S(R,S)
Q213	1	1	1	1	1	HT109332B0	Transistor 2SA933SP(R,S)
Q214	1	1	1	1	1	HT317402F0	Transistor 2SC1740S(R,S)
Q215	1	1	1	1	1	HT317402F0	Transistor 2SC1740S(R,S)
Q216	1	1	1	1	1	HT317402F0	Transistor 2SC1740S(R,S)
Q217	1	1	1	1	1	HT317402F0	Transistor 2SC1740S(R,S)
Q218	1	1	1	1	1	HT109332B0	Transistor 2SA933SP(R,S)
Q219	1	1	1	1	1	HT317402F0	Transistor 2SC1740S(R,S)

- (N): for Europe
- (A): for Australia
- (E): for Europe
- (P/PG): for PX
- (F): for Japan

REF. DESIG.	Q'TY					PART NO.	DESCRIPTION
	N	A	E	P/PG	F		
Q301	1	1	1	1	1	HC10001420	IC KB4437
Q302	1	1	1	1	1	HF200300B0	F.E.T. 2SK30A(YI)
Q303	1	1	1	1	1	HT317402F0	Transistor 2SC1740S(R,S)
Q304	1	1	1	1	1	HT317402F0	Transistor 2SC1740S(R,S)
Q305	1	1	1	1	1	HT109332B0	Transistor 2SA933P(R,S)
Q306	1	1	1	1	1	HG109332B0	Transistor 2SA933P(R,S)
Q307	1	1	1	1	1	HT317402F0	Transistor 2SC1740S(R,S)
Q308	1	1	1	1	1	HT317402F0	Transistor 2SC1740S(R,S)
Q309	1	1	1	1	1	HT317402F0	Transistor 2SC1740S(R,S)
Q310	1	1	1	1	1	HT317402F0	Transistor 2SC1740S(R,S)
Q311	1	1	1	1	1	HT317402F0	Transistor 2SC1740S(R,S)
Q312	1	1	1	1	1	HT109332B0	Transistor 2SA933P(R,S)
Q501	1	1	1	1	1	HC10103060	IC μ PD1704-552
Q502	1	1	1	1	1	HC10030060	IC μ PB553AC
Q503	1	1	1	1	1	HT109332B0	Transistor 2SA933SP(R,S)
Q504			1	1		HT109332B0	Transistor 2SA933SP(R,S) (ST-64)
Q504	1					HT109332B0	Transistor 2SA933SP(R,S) (ST-64L)
Q505	1	1	1	1	1	HT109332B0	Transistor 2SA933SP(R,S) (ST-64L)
Q506	1	1	1	1	1	HT317402F0	Transistor 2SC1740S(R,S)
Q507	1	1	1	1	1	HT317402F0	Transistor 2SC1740S(R,S)
Q508	1	1	1	1	1	HT317402F0	Transistor 2SC1740S(R,S)
Q509	1	1	1	1	1	HT317402F0	Transistor 2SC1740S(R,S)
Q510	1	1	1	1	1	HF200300B0	F.E.T. 2SK30A(Y)
Q511	1	1	1	1	1	HT317402F0	Transistor 2SC1740S(R,S)
Q512	1	1	1	1	1	HT317402F0	Transistor 2SC1740S(R,S)
Q513	1	1	1	1	1	HT317402F0	Transistor 2SC1740S(R,S)
Q514	1	1	1	1	1	HT317402F0	Transistor 2SC1740S(R,S)
Q515	1	1	1	1	1	HT317402F0	Transistor 2SC1740S(R,S)
Q801	1	1	1	1	1	HC10077030	IC L78M15
Q802	1	1	1	1	1	HT408631B0	Transistor 2SD863(E)
Q803	1	1	1	1	1	HT317402F0	Transistor 2SC1740S(R,S)
Q804	1	1	1	1	1	HT408631B0	Transistor 2SD863(E)
Q805	1	1	1	1	1	HT409852B0	Transistor 2SD985(L,K)
Q806	1	1	1	1	1	HT317402F0	Transistor 2SC1740S(R,S)
Q807	1	1	1	1	1	HT317402F0	Transistor 2SC1740S(R,S)
Q808	1	1	1	1	1	HT317402F0	Transistor 2SC1740S(R,S)
Q809	1	1	1	1	1	HT317402F0	Transistor 2SC1740S(R,S)
Q810	1	1	1	1	1	HT109332B0	Transistor 2SA933SP(R,S)
P100-MISCELLANEOUS							
A101	1	1	1	1	1	AV01202140	V.H.F. Tuner, FE407-A12
A101					1	AV01201060	V.H.F. Tuner, FE407-J12
FA01	1	1	1	1	1	FF10045310	Ceramic Filter, SFP450H
F201	1	1	1	1	1	FF11070570	Ceramic Filter, SFE10.7MS3G
F201			1	1	1	FF11070610	Ceramic Filter, SFE10.7MA8-A
F202	1	1	1	1	1	FF11070610	Ceramic Filter, SFE10.7MA8-A
F203	1	1	1	1	1	FF11070610	Ceramic Filter, SFE10.7MA8-A
F204	1	1	1	1	1	FF11070570	Ceramic Filter, SFE10.7MS3G
F204			1	1	1	FF11070610	Ceramic Filter, SFE10.7MA8-A

REF. DESIG.	Q'TY					PART NO.	DESCRIPTION
	N	A	E	P/PG	F		
J101	1	1	1	1		YT01050040	Terminal, FM Antenna; (5P)
J101					1	YT01040290	Terminal, FM Antenna; (4P)
J102	1	1	1	1	1	YT02020380	Terminal, Output; (2P)
J103	1	1	1	1	1	YT02020390	Terminal, Remote Cont. BUS.; (2P)
J104	1	1	1	1	1	YT02020400	Terminal, Easy BUS.; (2P)
LA01	1	1	1	1	1	LA10295140	Ant. Coil, AM
LA02	1					LA10295150	Ant. Coil, LW (ST-64L)
LA03	1	1	1	1	1	LO10013170	OSC Coil, MW
LA04	1					LO10013180	OSC Coil, LW (ST-64L)
LA05	1	1	1	1	1	LI10013270	I.F.T. Coil, AM
L201	1	1	1	1	1	LI10016010	I.F.T. Coil, FM
L202	1	1	1	1	1	LI10159010	I.F.T. Coil, FM DET Sub
L203	1	1	1	1	1	LI14030030	I.F.T. Coil, FM DET
L204	1	1				LS10295030	M.P.X. Coil, Anti Birde Filter
L205	1	1	1	1	1	LC24750600	Choke Coil, 4.7mH
S101			1	1		SS02020730	Slide Switch, Scan/Stop (ST-64)
X501	1	1	1	1	1	XB108001L2	Crystal, 4.5MHz
P900-DISPLAY CIRCUIT BOARD							
P900	1	1	1	1	1	YK459H1630	P.W. Board, Display
	1	1	1	1		ZZ459H8630	P.W. Board Assembly (ST-64)
	1					ZZ460H8630	P.W. Board Assembly (ST-64L)
C901	1	1	1	1	1	DK18103310	Ceramic Cap. 0.01 μ F
C902	1	1	1	1	1	DK18103310	Ceramic Cap. 0.01 μ F
Q901	1	1	1	1	1	HC10077060	IC μ PD6320G
V901	1	1	1	1	1	HQ30903060	Display Unit, FIP7B8AS (ST-64)
V901	1					HQ31002060	Display Unit, FIP7A8AS (ST-64L)
W901	1	1	1	1	1	YU08200260	Jumper Lead, 8P
W902	1	1	1	1	1	YU07080260	Jumper Lead, 7P
PR00-MODE LAMP CIRCUIT BOARD							
PR00	1	1	1	1	1	YK459H1660	P.W. Board, Mode Lamp
	1	1	1	1		ZZ459H8660	P.W. Board Assembly
VR01	1	1	1	1	1	IN10080610	Lamp 50mA 8V
VR02	1	1	1	1	1	IN10080610	Lamp 50mA 8V

- (N): for Europe
- (A): for Australia
- (E): for Europe
- (P/PG): for PX
- (F): for Japan

REF. DESIG.	Q'TY					PART NO.	DESCRIPTION
	N	A	E	P _{PG}	F		
PS00	1	1	1	1	1	YK459H1650	PS00-POWER/MODE CIRCUIT BOARD P.W. Board, Power/Mode
	1	1	1	1	1	ZZ459H8650	P.W. Board Assembly
RS01	1	1	1	1	1	GD05103140	Resistor 10KΩ ±5% ¼W
RS02	1	1	1	1	1	GD05100140	Resistor 10Ω ±5% ¼W
QS01	1	1	1	1	1	HT317402F0	Transistor 2SC1740S(R,S)
SS01	1	1	1	1	1	SP02011000	Push Switch, Power
SS02	1	1	1	1	1	SP02011230	Push Switch, Mode
WS01	1	1	1	1	1	YU08200260	Jumper Lead, 8P
WS02	1	1	1	1	1	YU03080260	Jumper Lead, 3P
PT00	1	1	1	1	1	YK459H1620	PT00-PRESET SWITCH CIRCUIT BOARD P.W. Board, Preset Switch
	1	1	1	1	1	ZZ459H8620	P.W. Board Assembly (ST-64)
	1	1	1	1	1	ZZ460H8620	P.W. Board Assembly(ST-64L)
	1	1	1	1	1		
RT01	1	1	1	1	1	GD05103140	PT00-RESISTORS (All Resistors are ±5% & ¼W) 10KΩ
	1	1	1	1	1	GD05470140	47Ω
	1	1	1	1	1	GD05470140	47Ω
	1	1	1	1	1	GD05470140	47Ω
	1	1	1	1	1	GD05100140	10Ω
	1	1	1	1	1	GD05100140	10Ω
	1	1	1	1	1	GD05182140	1.8KΩ
	1	1	1	1	1		PT00-SEMICONDUCTORS
	1	1	1	1	1	HI10038030	L.E.D. SLP-981C-50
DT08	9	9	9	9	9	HI10044320	L.E.D. GL-9PR26
DT09	9	9	9	9	9	HI10044320	L.E.D. GL-9PR26
DT17	9	9	9	9	9	HI10044320	L.E.D. GL-9PR26
QT01	1	1	1	1	1	HC10062020	IC AN6876
ST01	1	1	1	1	1	SP01010570	PT00-MISCELLANEOUS Push Switch
	1	1	1	1	1	SP01010570	Push Switch, FM (ST-64)
	1	1	1	1	1	SP01010570	Push Switch, MW (ST-64L)
	1	1	1	1	1	SP01010570	Push Switch, FM (ST-64L)
	1	1	1	1	1	SP01010570	Push Switch, AM (ST-64)
	1	1	1	1	1	SP01010570	Push Switch, LW (ST-64L)
	1	1	1	1	1	SP01010570	Push Switch, LW (ST-64L)
VT01	1	1	1	1	1	IN10080620	Lamp 50mA 8V, Memory
VT02	1	1	1	1	1	IN10080620	Lamp 50mA 8V, Fine
WT01	1	1	1	1	1	YU08200260	Jumper Lead, 8P
WT02	1	1	1	1	1	YU06200260	Jumper Lead, 6P
WT03	1	1	1	1	1	YU03200260	Jumper Lead, 3P

REF. DESIG.	Q'TY					PART NO.	DESCRIPTION
	N	A	E	P _{PG}	F		
PU00	1	1	1	1	1	YK459H1640	PU00-IF BAND CIRCUIT BOARD P.W. Board, IF Band
	1	1	1	1	1	ZZ459H8640	P.W. Board Assembly
CU01	1	1	1	1	1	EA22505010	Elect Cap. 22μF 50V
RU01	1	1	1	1	1	GD05473140	Resistor 47KΩ ±5% ¼W
RU02	1	1	1	1	1	GD05472140	Resistor 4.7KΩ ±5% ¼W
RU03	1	1	1	1	1	GD05222140	Resistor 2.2KΩ ±5% ¼W
RU04	1	1	1	1	1	GD05222140	Resistor 2.2KΩ ±5% ¼W
RU05	1	1	1	1	1	GD05100140	Resistor 10Ω ±5% ¼W
DU01	1	1	1	1	1	HI10044310	L.E.D. GL-9PR26, Wide
DU02	1	1	1	1	1	HI10044320	L.E.D. GL-9PR26, Nallow
QU01	1	1	1	1	1	HT317402F0	Transistor 2SC1740S(R,S)
SU01	1	1	1	1	1	SP01010570	Push Switch, PGM. Record
SU02	1	1	1	1	1	SP01010570	Push Switch, Monitor
SU03	1	1	1	1	1	SP01010570	Push Switch, IF Band
VU01	1	1	1	1	1	IN10080620	Lamp 50mA 8V, PGM. Record
WU01	1	1	1	1	1	YU06200260	Jumper Lead, 6P
WU02	1	1	1	1	1	YU03200260	Jumper Lead, 3P

(W01-99)	Assembly and Wiring
(T01-99)	Adjustment
(X01-00)	Correction

NOTE ON SAFETY:

Symbol Δ Fire or electrical shock hazard. Only original parts should be used to replace any part marked with symbol Δ . Any other component substitution (other than original type), may increase risk of fire or electrical shock hazard.

11. TECHNICAL SPECIFICATIONS

FM TUNER SECTION

Frequency Range	87.5 ~ 108 MHz
Usable Sensitivity	
Mono (S/N 26 dB, 75 ohms)	0.7 μ V
Stereo (S/N 46 dB, 75 ohms)	20 μ V
Alternate Channel Selectivity 98 MHz (W/N)	40/75 dB
Image Response Rejection	80 dB
IF Rejection	110 dB
Spurious Response Rejection	95 dB
AM Suppression	60 dB
Signal-to-Noise Ratio	
Unweighted Mono	78 dB
Stereo	73 dB
Weighted Mono	85 dB
Stereo	76 dB
Pilot Signal & Subcarrier Rejection	
19 kHz	60 dB
38 kHz	65 dB
Total Harmonic Distortion	
Mono (W/N)	0.05/0.15%
Stereo (W/N)	0.08/0.3%
Frequency Response	
30 Hz ~ 15 kHz	+0.5 dB, -1.5 dB
Separation	
Stereo (W/N)	55/50 dB
Channel Balance	0.2 dB

MW TUNER SECTION

Frequency Range	531 ~ 1602 kHz
Usable Sensitivity 20 dB S/N 30% Mod., 999 kHz	350 μ V/m
Selectivity 999 kHz, \pm 9 kHz	60 dB
Image Rejection, 999 kHz	45 dB
IF Rejection, 999 kHz	70 dB
Signal-to-Noise Ratio, 999 kHz	54 dB
Total Harmonic Distortion, 999 kHz	0.3%

LW TUNER SECTION

Frequency Range	153 ~ 281 kHz
Usable Sensitivity 20 dB S/N 30% Mod., 250 kHz	800 μ V
Image Rejection, 250 kHz	50 dB
IF Rejection, 250 kHz	65 dB
Signal-to-Noise Ratio, 250 kHz	50 dB

GENERAL

Power Requirements (ST-64)	110/120/220/240V AC, 50/60 Hz
(ST-64L)	220/240V AC, 50/60 Hz
Power Consumption at Rated Output, Both Channels Operating	12W
Dimensions	
Panel Width	416 mm
Panel Height	73 mm
Depth	295 mm
Weight	
Unit Alone	3.4 kg

Specifications and appearance are subject to change for modification without notice.

12. SCHEMATIC DIAGRAM

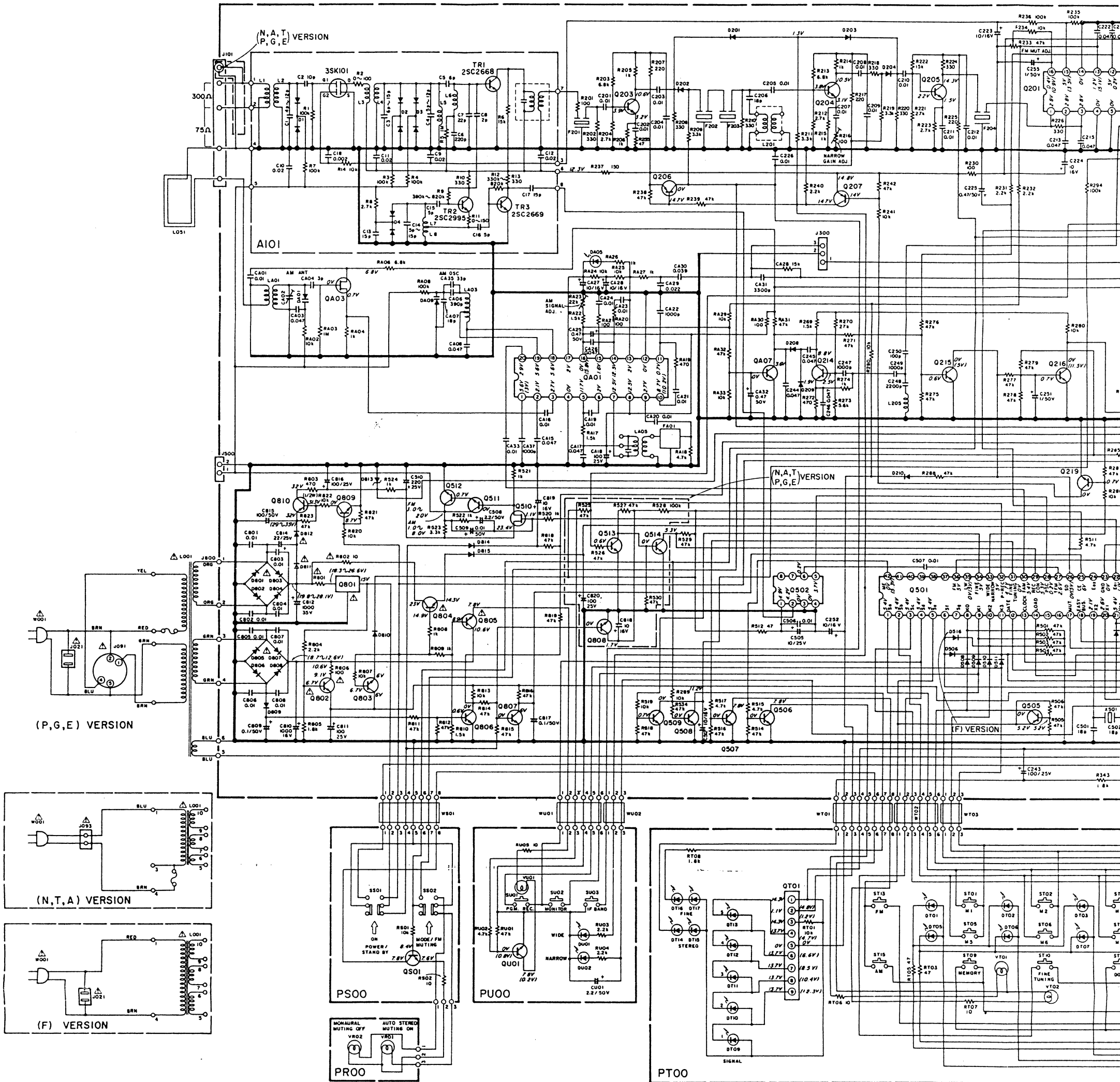

NOTE ON SAFETY :
 Symbol \triangle Fire or electrical shock hazard. Only original parts should be used to replace any part marked with symbol \triangle . Any other component substitution (other than original type), may increase risk of fire or electrical shock hazard.

Model ST-64

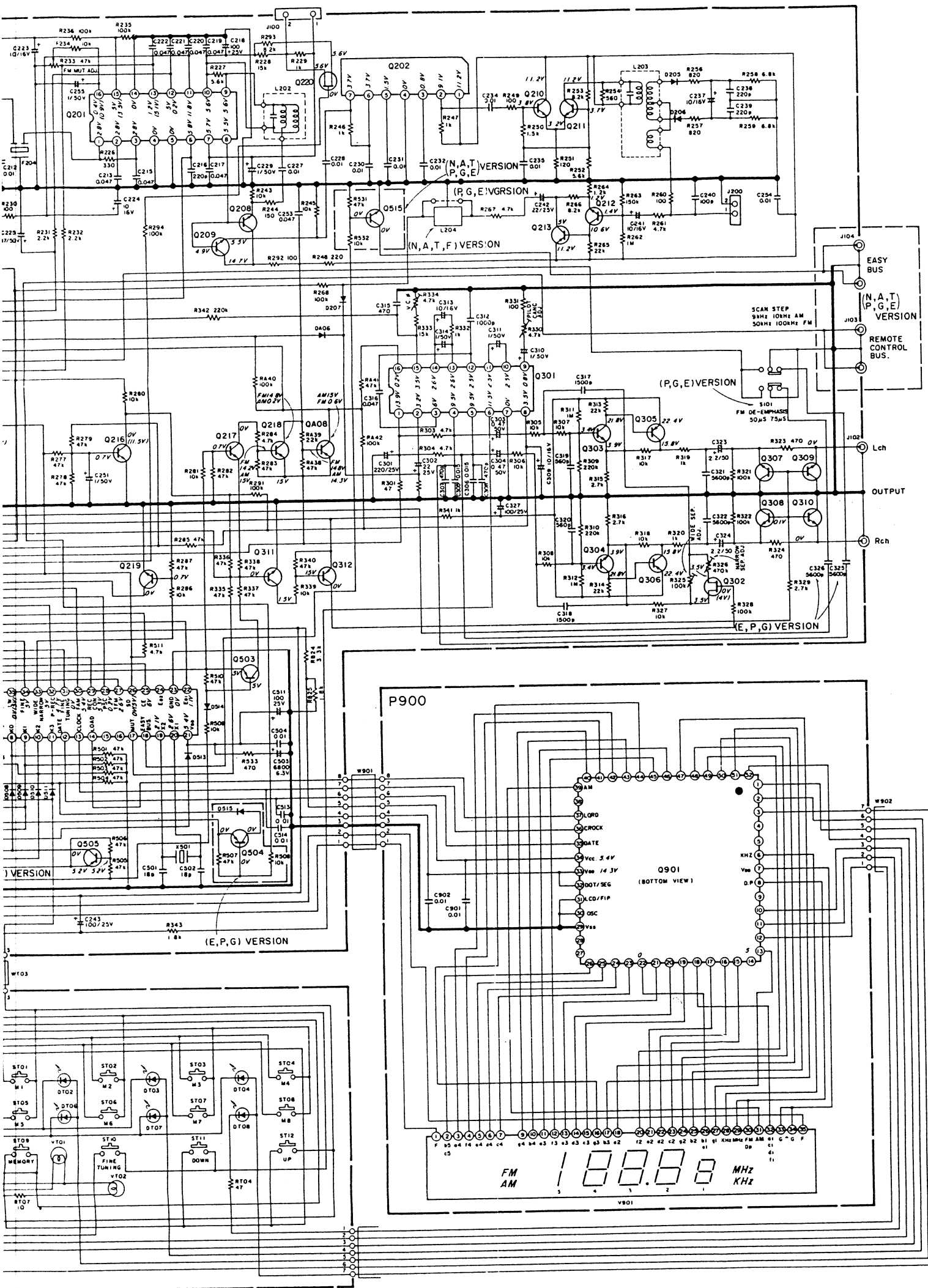

- Q401
HC10058030
LA1245
- Q701
HC10062020
AN6876
- Q201
HC10028030
LA1231
- Q202
HC10017060
μPC1163H
- Q301
HC10001420
KB4437
- Q501
HC10013060
μPC1704C-552
- Q502
HC10030060
μPB553AC
- Q801
HC10077030
L78M15
- Q901
HC10077060
μPD6320G
- Q403
HF200551D0
25K550
- Q302, Q510, Q220
HF20030080
25K30A (Y1)
- Q407, Q501, Q401, Q212
Q214 ~ Q217, Q219, Q303
Q304, Q307 ~ Q311, Q506
Q507 ~ Q509, Q511 ~ Q515
Q803, Q806 ~ Q809
HT31740270
25C17405 (R or S)
- Q408, Q206
Q207, Q213, Q218, Q305
Q306, Q312, Q503, Q504
Q505, Q810
HT10933280
25A9333P (R or S)
- Q802, Q804
HT40863180
250863 (E)
- Q805
HT40985280
250985 (L, K)
- DA02
DA06, D201, D202, D203
D204, D205, D206, D207
D208, D209, D210, D501
D502, D503, D504, D505
D506, D508
D510, D511, D512, D513
D514, D515, D516,
D810, D814
HD20001000
IS1555, IS2473, DS448
MA150, ETC.
- DT01 ~ DT08
HT10038030
SLP-981C-50
- DT09 ~ DT17, DU01, DU02
DA05
HT10044320
GL-9PR26
- D801 ~ D809, D811, D812
HD20022030
DSF10C
- DA01
HD40006030
SVC321SP
- D813
HD30015020
MA1240
- Q203 ~ Q205, Q208 ~ Q211
HT310471C0
25C1047C

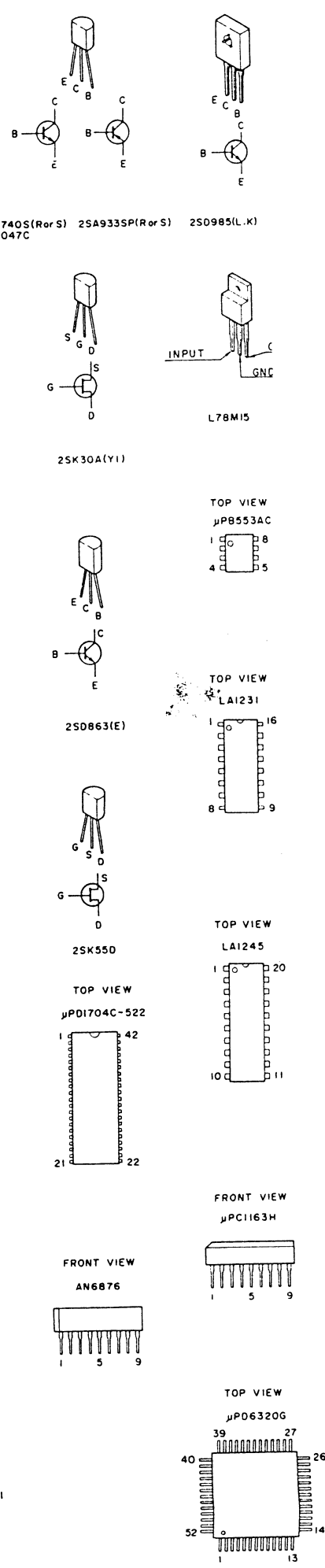

Components and wiring are subject to change for modification without notice.

Model ST-64L

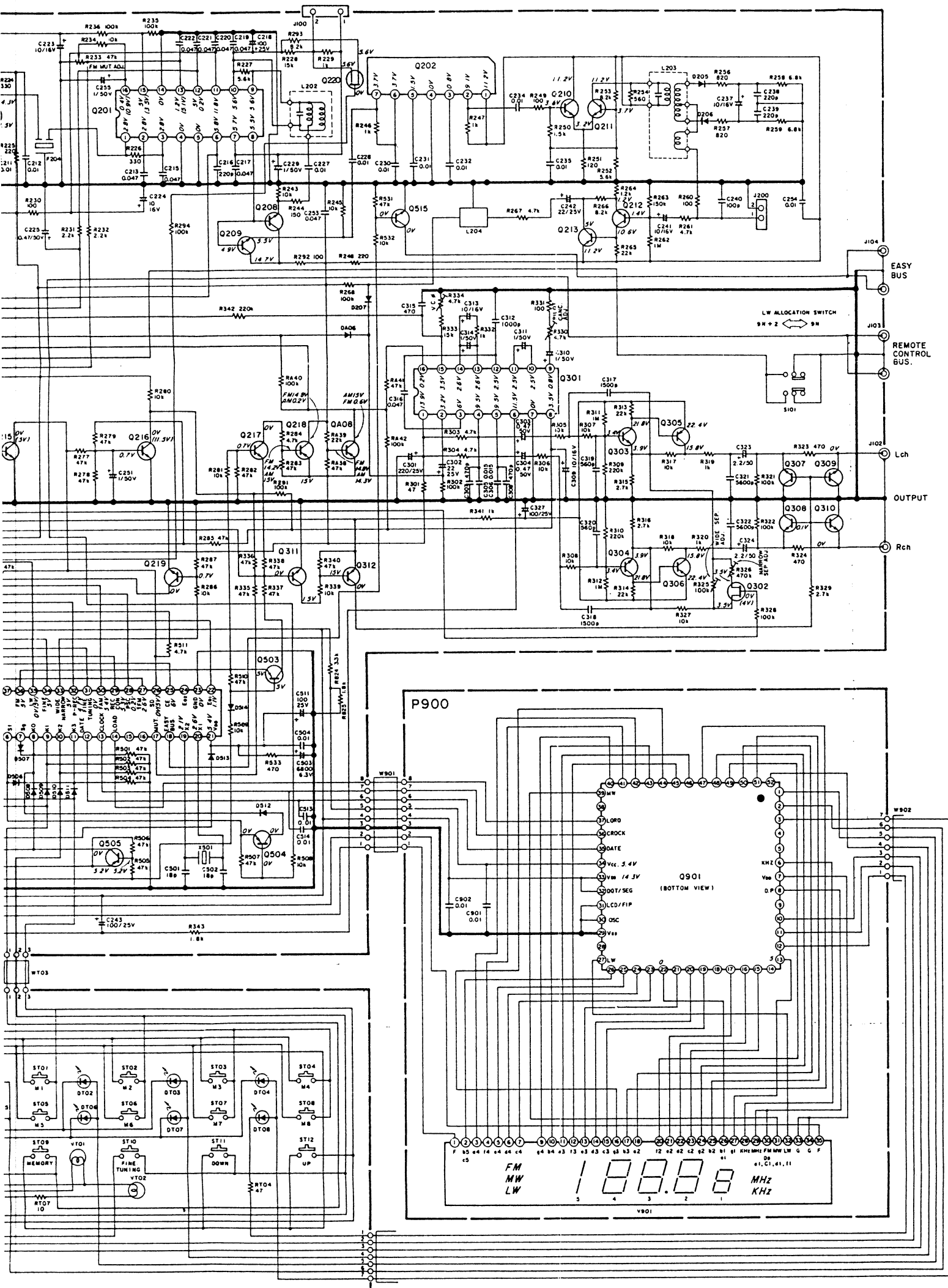

- QA01
HC10058030
LA1245
- Q201
HC10028030
LA1231
- Q202
HC10017060
μPC1163H
- Q301
HC10001420
KB4437
- Q501
HC10103060
μPC1704C-552
- Q502
HC10030060
μP8553AC
- Q801
HC10077030
L78M15
- Q901
HC10077060
μP6320G
- QA03, QA05
HF20055100
2SK35D
- QA02
HT406551E0
2SD655(E)
- QA04, QA06, Q302, Q510
Q220 HF20030080
2SK30A (Y1)
- QA07, Q501, Q212
Q214 ~ Q217, Q219, Q303
Q304, Q307 ~ Q311, Q506
Q507 ~ Q509, Q511 ~ Q515
Q803, Q806 ~ Q809, QA09
HT317402F0
2SC1740S (R or S)
- QA08, QA10, QA11, Q206
Q207, Q213, Q218, Q305
Q306, Q312, Q503, Q504
Q505, Q810
HT10933280
2SA933SP (R or S)
- Q802, Q804
HT40863180
2SD863 (E)
- Q805
HT40985280
2SD985(L, K)
- DA02, DA04, DA06, DA07
DA08, D201, D202, D203
D204, D205, D206, D207
D208, D209, D210, D501
D502, D503, D504, D505
D506, D507, D508,
D510, D511, D512, D513
D514, D515, D516,
D810, D814
HD20001000
IS1555, IS2473, DS448
MA150, ETC.
- DT01 ~ DT08
HT10038030
SLP-981C-50
- DT09 ~ DT17, DU01, DU02
DA05
HI10044320
GL-9PR26
- DB01 ~ DB09, DB11, DB12
HD20022030
DSF10C
- DA01, DA03, DA09, DA10
HD40006030
SVC321SP
- DB13
HD30015020
MA1240
- Q203 ~ Q205, Q208 ~ Q211
HT310471C0
2SC1047C

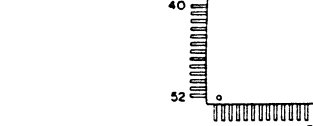
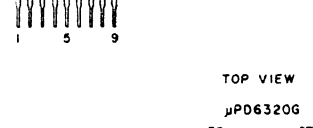
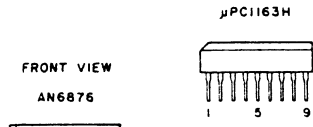
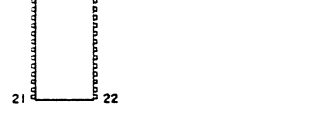
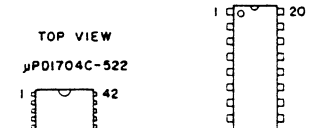
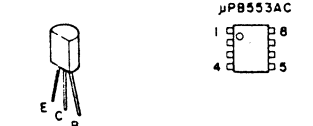
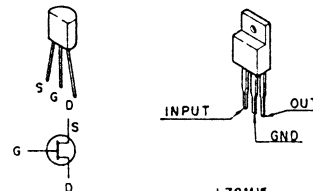
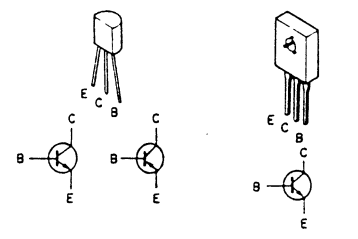

Components and wiring are subject to change for modification without notice.