

SERVICE
MANUAL



TT530

marantz®

Model *TT530*

Turntable

MARANTZ DESIGN AND SERVICE

Using superior design and selected high grade components, MARANTZ company has created the ultimate in stereo sound. Only **original MARANTZ parts** can insure that your MARANTZ product will continue to perform to the specifications for which it is famous.

Parts for your MARANTZ equipment are generally available to our National Marantz Subsidiary or Agent.

ORDERING PARTS:

Parts can be ordered either by mail or by telex. In both cases, MARANTZ part number has to be specified. If you order by mail, fulfil MARANTZ order forms.

MARANTZ S.A.
EUROPEAN PARTS DEPARTMENT
2, Avenue Léopold III
B-7120 PERONNES-lez-BINCHE
BELGIUM
TWX: 57589 SEPLT B

SUPERSCOPE NATIONAL PARTS DEPARTMENT
20525 Nordhoff Street
Chatsworth, California 91311
Phone: 1-800-423-5108
Phone: 1-213-998-9333

The following information must be supplied to eliminate delays in processing your order:

1. Complete address
2. Complete part numbers and quantities required
3. Description of parts
4. Model number for which part is required
5. Way of shipment
6. Signature: any order form or telex must be signed otherwise such part order will be considered as null and void.

PARTS ORDERING:

Parts may be ordered from the following addresses:

EUROPE

MARANTZ S.A.
European Parts Department
2, Avenue Léopold III
B-7120 Péronnes-lez-Binche
Belgium
Telex: 57589

MARANTZ GERMANY GMBH
Max Planckstrasse, 22
6072 DREIEICH 1
West Germany
Telex: 4185316

MARANTZ FRANCE
4 Rue Bernard Palissy
92600 Asnières
France
Telex: 611651

MARANTZ DENMARK
Bregnerødvej 132b
3460 Birkerød
Denmark
Telex: 39137

MARANTZ GMBH AUSTRIA
Wiedner Hauptstrasse 98
1050 Wien
Austria
Telex: 113583

MARANTZ S.A.
326 Avenue Louise Bte 32
1050 Brussels
Belgium
Telex: 26602

MARANTZ NORSKE A.S.
Refstadalleen 13
Oslo 5
Norway
Telex: 19659

MARANTZ AUDIO U.K. LTD.
Unit 15/16
Saxon Way Industrial Estate
Moor Lane
Harmondsworth UB7 OLW
Great Britain
Telex: 935196

MARANTZ BELGIUM
45 Rue Auguste Van Zande
1080 Brussels
Belgium

MARANTZ SVENSKA A.B.
Svartviksvangen 56
Traneberg - Box 12016
16112 Bromma
Sweden
Telex: 13449

AUSTRALIA

MARANTZ AUSTRALIA PTY., LTD.
32 Cross Street
Brookvale, N.S.W. 2100
Australia
Telex: 24121

U.S.A.

MARANTZ COMPANY, INC.
National Service Dept.
P.O. Box 577
Chatsworth, CA 91311
U.S.A.
Telex: 4720284

CANADA

SUPERSCOPE CANADA, LTD.
3710 Nashua Drive
Mississauga
Ontario, Canada L4V1M5

JAPAN

MARANTZ JAPAN, INC.
35-1, 7-chome, Sagami-cho
Sagamihara-shi, Kanagawa
Japan
Telex: 22878

All of the above locations are fully equipped to take care of your total service needs. Because various countries have differing configuration requirements, it is necessary that you contact the service facility in your particular country. In the event that there is no service location listed for your country, please, contact the nearest facility for the necessary assistance.

In case of difficulties, do not hesitate to contact the Technical Department at abovementioned address.

NOTE—FOR U.S.A. ONLY

Parts for your MARANTZ stereo are generally available within 72 hours throughout the nation via a toll-free line to our National Parts Depot in California. The sales professionals who take your call immediately refer to their own desk top computer terminal and can quickly determine the availability and price information you require. If, for some reason, your order should exceed our available stock, we usually can instantly provide an alternate replacement part or current delivery information. When the order is placed and confirmed, the computer simultaneously generates "hard copy" orders at the distribution center. As hard copies come directly from the computer to the national parts depot, your requested stock is assembled and prepared for shipment and placed on the first available carrier for delivery to you.

Phone orders will eliminate mail delays, and we encourage the use of this method. If you order by mail, use MARANTZ parts order forms which are available from SUPERSCOPE NATIONAL PARTS DEPARTMENT.

marantz®

TABLE OF CONTENTS

	Page
DESIGNATION OF PARTS	2
1. SHOCK, FIRE HAZARD SERVICE TEST	2
2. MECHANISM OPERATING PRINCIPLES	2
3. DISASSEMBLY INSTRUCTIONS	3
4. REPLACING AND REASSEMBLY INSTRUCTIONS	4
5. ADJUSTMENTS	6
6. TROUBLESHOOTING	7
7. SCHEMATIC DIAGRAM	9
8. WIRING DIAGRAMS	10
9. CONTROLLER CIRCUIT DIAGRAMS	12
10. PRINTED WIRING BOARDS	14
11. EXPLODED VIEW	16
12. PACKING MATERIALS	17
13. PARTS LIST	18

FEATURES

Linear Tracking Direct Drive Turntable

SPECIFICATIONS (Limit)

TURNTABLE		Output voltage	3 mV \pm 3dB at 1 KHz 3.54 cm/sec.
Motor	20-pole 30-slot 3-phase brushless type DC servo controlled direct-drive motor	Channel balance	Within 2dB at 1 KHz
Speeds	33-1/3 and 45 r.p.m.	Channel separation	More than 18dB at 1 KHz
Speed calibration	Pitch control \pm 3%	Load resistance	47 K Ω
Wow & Flutter	\pm 0.15% (DIN45507)	Weight	6 g
Rumble	36dB DIN45539A (unweighted) 62dB DIN45539B (weighted)	OPERATION	Microcomputer-controlled fully automatic: Automatic start, return, repeat and record size selector by beam sensor
Turntable platter	296mm aluminum alloy die-cast with strobe outside rim (for 33-1/3 r.p.m.)	Cueing	DC motor controlled
TONARM		Muting	Reed relay method avoiding shock noise
Effective length	130 mm	Speed selector	Automatic selection by beam sensor (switchable for manual operation)
Tracking error	Within 0.1°	GENERAL	
Usable cartridge	Universal, P-mount type	Power consumption	12 watts
CARTRIDGE		Dimensions	416(w) \times 94(h) \times 346(d) mm
Type	P-mount system, with 0.6 mil stylus Induced Magnet type	Weight	4.5 Kg(net)
Frequency response	20–20,000 Hz		

NOTE: Nominal Specs represent the design specs; all units should be able to approximate these—some will exceed and some may drop slightly below these specs. Limit Specs represent the absolute worst condition which still might be considered acceptable; in no case should a unit perform to less than within any Limit Spec.

Lubrication of the mechanism is not required. However, whenever a unit is brought in for adjustment or repair, always use good common sense ... clean any dust or dirt from mechanical parts and if moving parts do seem to bind, check for dirt. If necessary, add a very fine film of light-weight specially formulated lubricant.

DESIGNATION OF PARTS

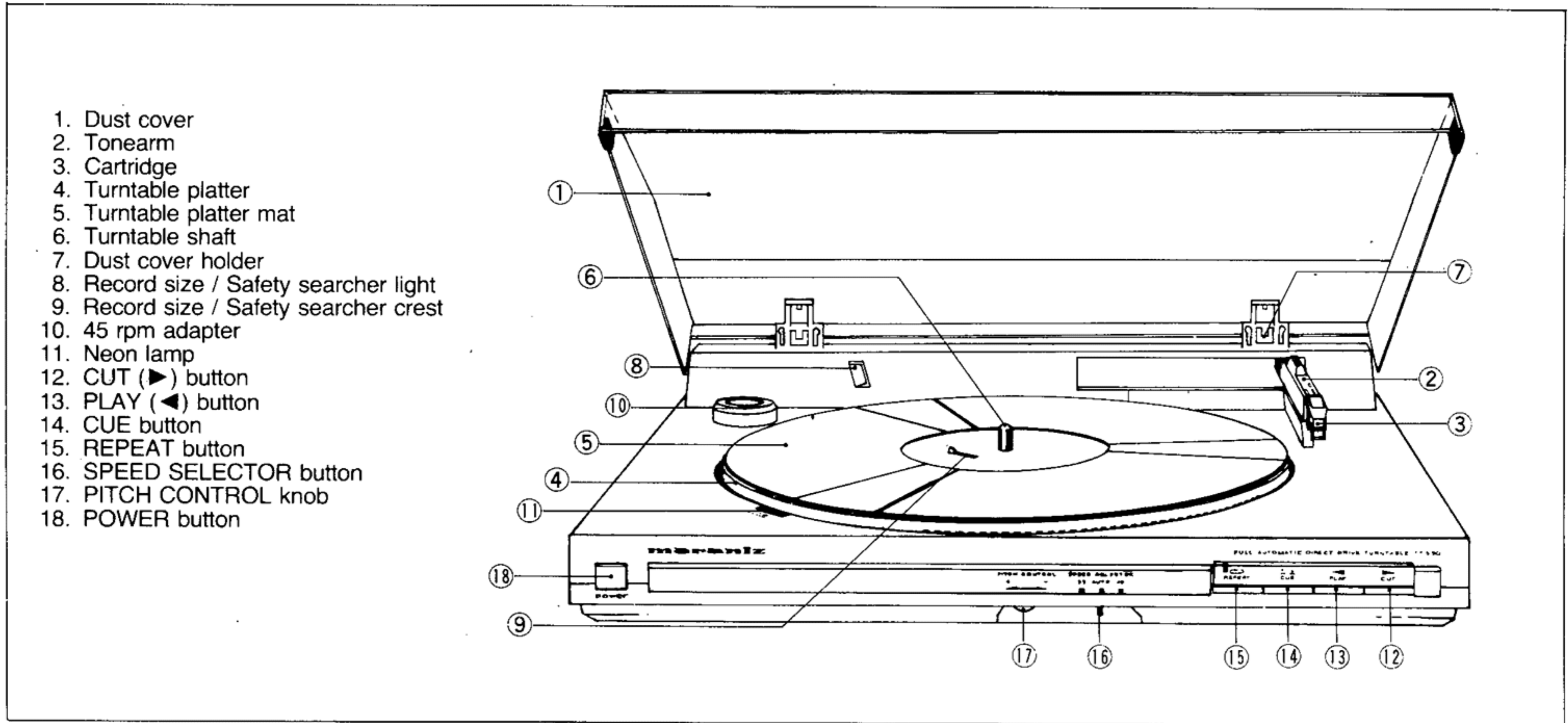

1. SHOCK, FIRE HAZARD SERVICE TEST

CAUTION: After servicing this appliance and prior to returning to customer, measure the resistance between either primary AC cord connector pins (with unit NOT connected to AC mains and its Power switch ON), and the face or front Panel of product and controls and chassis bottom.

Any resistance measurement less than 1 Megohms should cause unit to be repaired or corrected before AC power is applied, and verified before return to user/customer.

Ref. UL Standard No. 1270. Para. 66. 3. D (Mandatory Test after servicing Electrical Appliances, effective 7-1-83).

2. MECHANISM OPERATING PRINCIPLES

(A) RECORD SIZE SEARCHER MECHANISM

An optical sensor equipped with this unit automatically searches the size of record and the existence of record as well. The sensor system consists of the lamp, photo transistor and the slits on turntable platter.

One of the two slits on turntable platter has the crest which works as a shutter. When no record is placed on the platter, the Photo transistor receives light from the lamp twice a turn through the two slits; when a 17 cm record is placed, the photo transistor receives light once a turn through the slit without crest.

The pulse of light which photo transistor gets is transmitted to the microcomputer, and the pulse of light is sensed as the size or the non-existence of record by the Microcomputer (IC03). Then the microcomputer transmits the command-signal of speed to the motor: for 30 cm record 33-1/3 rpm, for 17 cm record 45 rpm, for no record no rotation.

(B) TRACKING ERROR CORRECTION MECHANISM

The tonearm tracking error is searched by the Sensor (PC201) on Phono PWB (67-1) and the shutter plate mounted to the tonearm. The sensitivity of the sensor has been adjusted by (VR01). No tracking error point has been settled by the correct positioning of phono PWB with (VR02). The tracking error, if occurs, will be corrected as follows:

When the tracking error angle is created, the intensity of light which the sensor gets will be varied. The variety of intensity of light will be converted to the current which flows the sensor. The degree of tracking angle is almost in direct proportion to the current near 0 degree with correct adjustment of positioning.

The current will be converted to the voltage and will be then amplified so that the signal amplified starts rotating the Servo-controlled Motor (76). The rotation of the motor will be transmitted to the Worm Gear (31) by the Belt (34). The Worm Wheel Gear (35) bit the worm gear will roll the wire so that the Bracket K (47) on which the tonearm stands will be moved.

When the tonearm is moved to the position where the tracking error angle is disappeared, the shutter plate will obstruct the light to the sensor. The current will become lower, the voltage will become lower too, and then servo-controlled motor will stop rotation.

3. DISASSEMBLY INSTRUCTIONS

(A) TOOLS REQUIRED FOR DISASSEMBLY

Phillips-head screwdrivers: for M2 and M3
 Slotted-head screwdrivers: for the width 2.5~4 and 5~7.5 mm

(B) REMOVE CASE TOP (1) AS FOLLOWS:

1. In case that the tonearm starts moving normally,

- 1-1. Press the POWER Button (5) so that the power will be switched off, and remove the turntable platter and mat (Fig. 1).

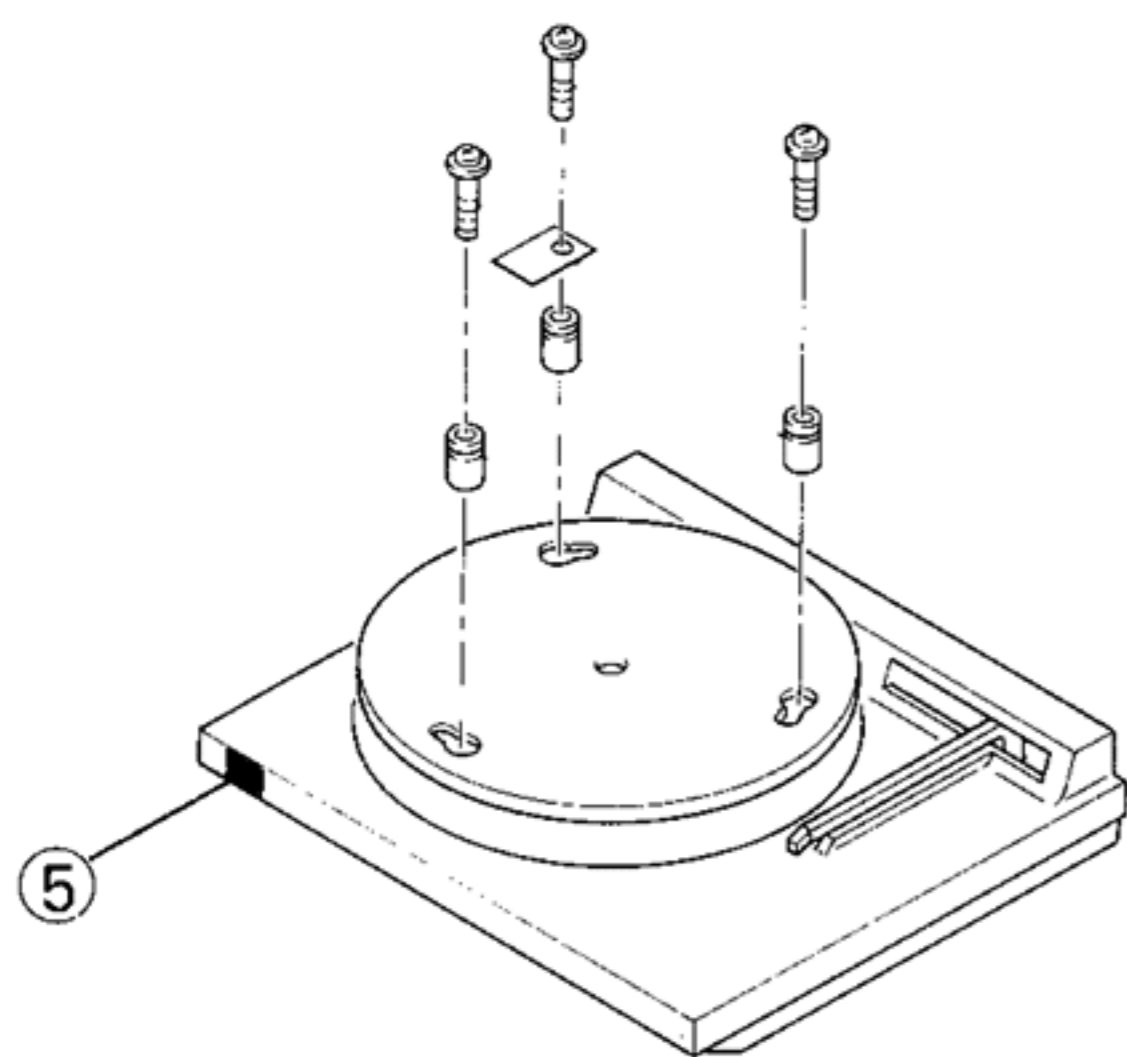

Figure 1

- 1-2. Place the turntable upside down on a suitable bench.
- 1-3. Remove the seven Screws (207) which mount the Case bottom (15) (Fig. 2).

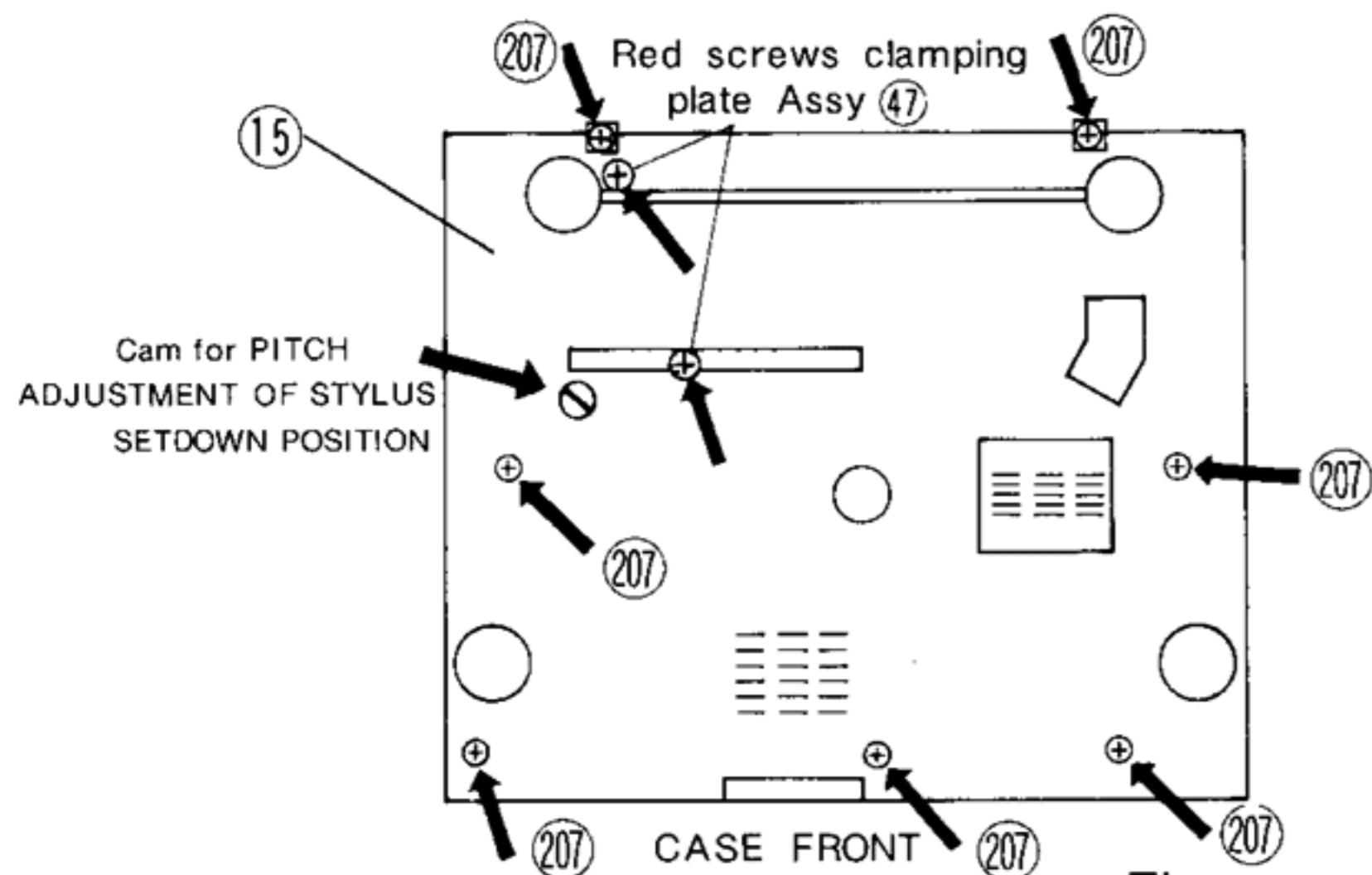

Figure 2

- 1-4. Reverse the turntable.
- 1-5. Remove the screw (206) which mounts the Cover (10) to the Case top (1).
- 1-6. Remove the Cover (10) from the case top by drawing it (Fig. 3).
- 1-7. Press the POWER button so that the power will be switched on and remove the tonearm to the position

where the Cover (10) was mounted, pressing the PLAY button.

- 1-8. Press the POWER button to switch the unit off.
- 1-9. Remove the three Screws (207) which mount the case top (Fig. 4) and lift the case top.

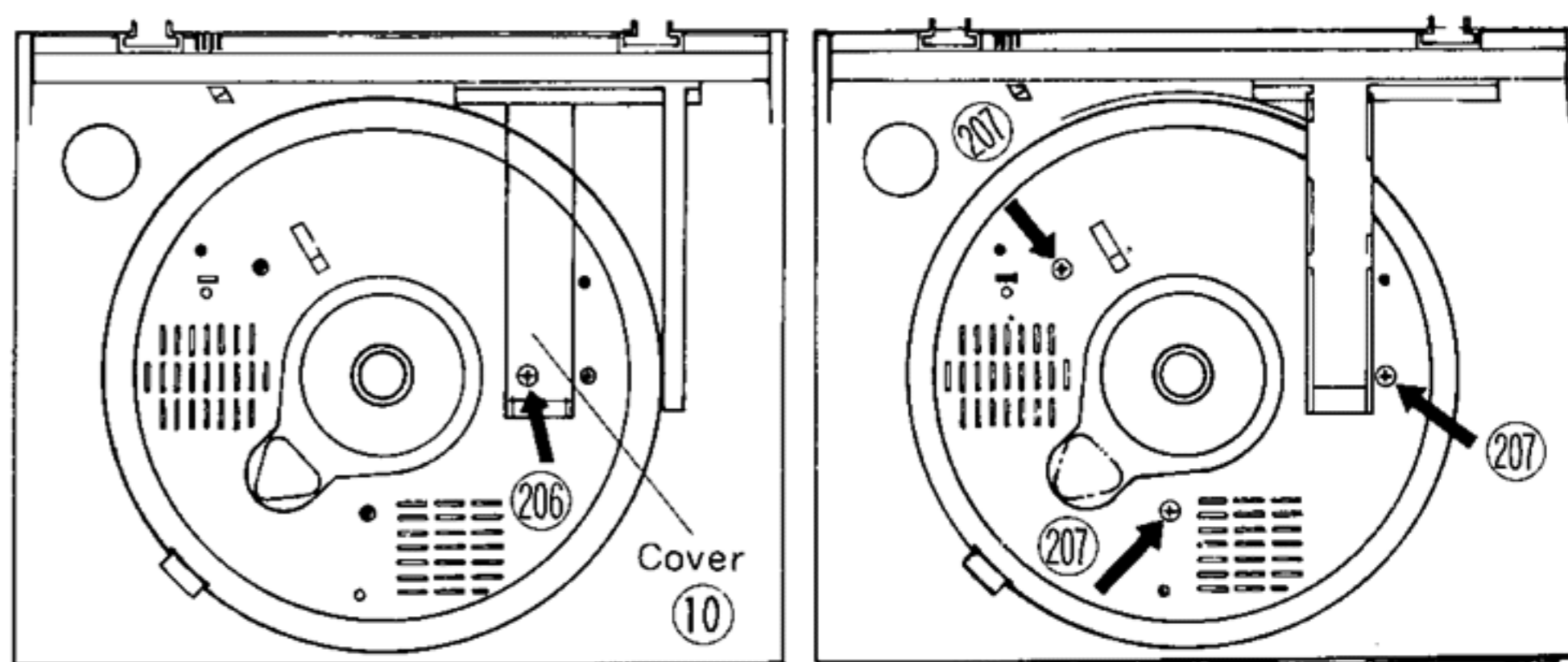

Figure 3

Figure 4

2. In case that the tonearm does not start moving with trouble,

- 2-1. If the tonearm is above or on the turntable platter, turn the Pulley (33) counterclockwise through the hole referring to Fig. 5 with the slotted-head screwdriver (width 2.5 ~ 4 mm) until tonearm moves to its rest position.
- 2-2. Remove the turntable platter and mat.
- 2-3. Follow the same steps as described above 1-2, 1-3, 1-4, 1-5 and 1-6.
- 2-4. Move the tonearm to the position where the Cover (10) was mounted, turning the Pulley (33) clockwise (Fig. 5).
- 2-5. Follow the same step as above 1-9.

NOTE: If the tonearm does not move by turning the Pulley (33) (Fig. 5), an additional force by finger should be added to the bended part of tonearm in the desired direction.

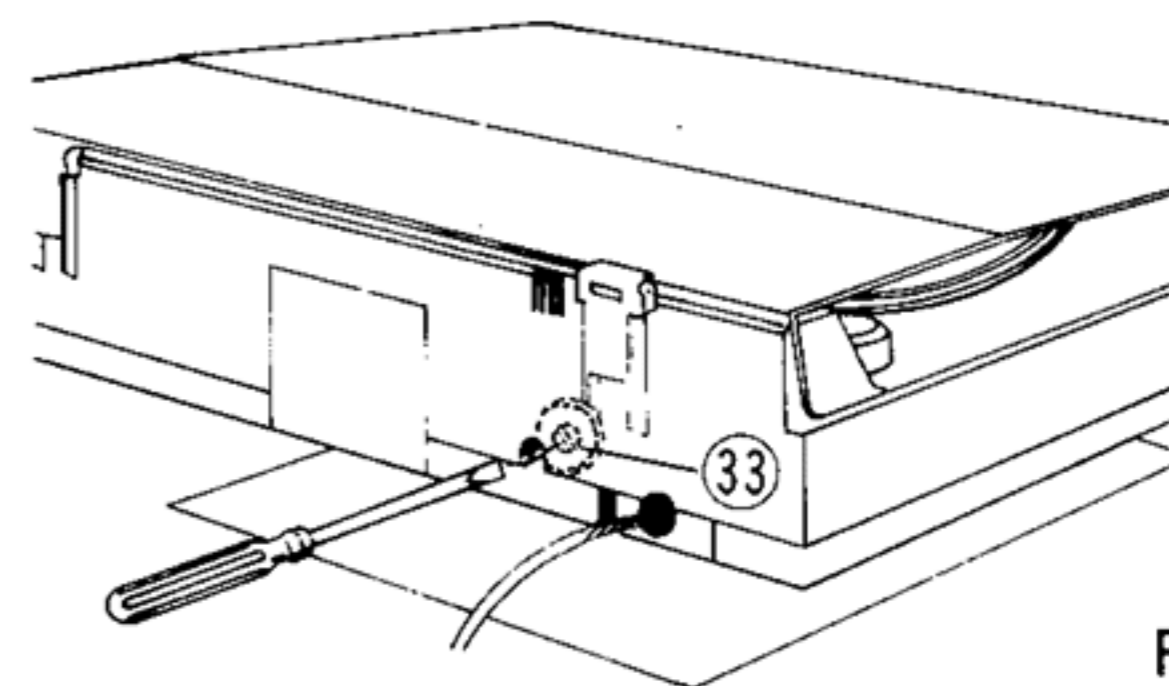

Figure 5

(C) REMOVE THE BRACKET K (47) AS FOLLOWS:

1. After removing the case top, remove Position PWB Assy (69) referring to Fig. 6.
2. Remove the Belt (34) between Servo-controlled Motor (76) and Pulley (33).
3. Remove the Sustainer K (30) referring to Fig. 7.

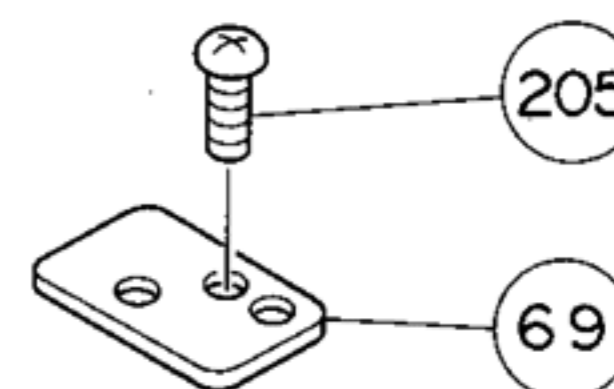

Figure 6

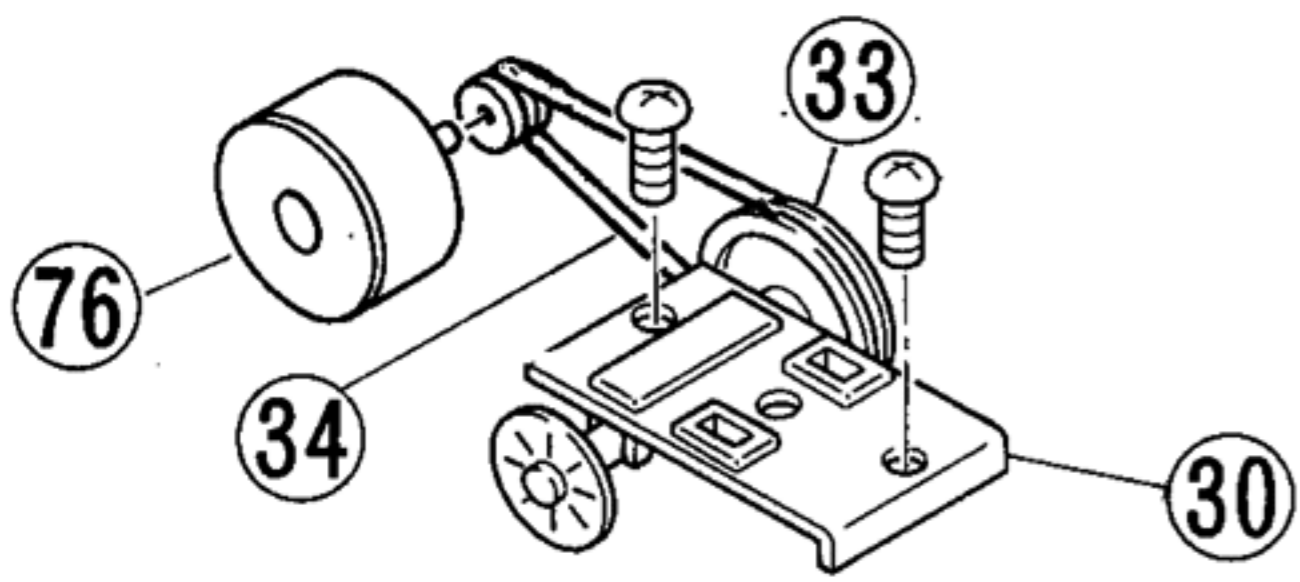

Figure 7

4. After removing the Screw (202) described in Fig. 8, remove the Bracket K (47) by lifting the left end of the Guide (42).

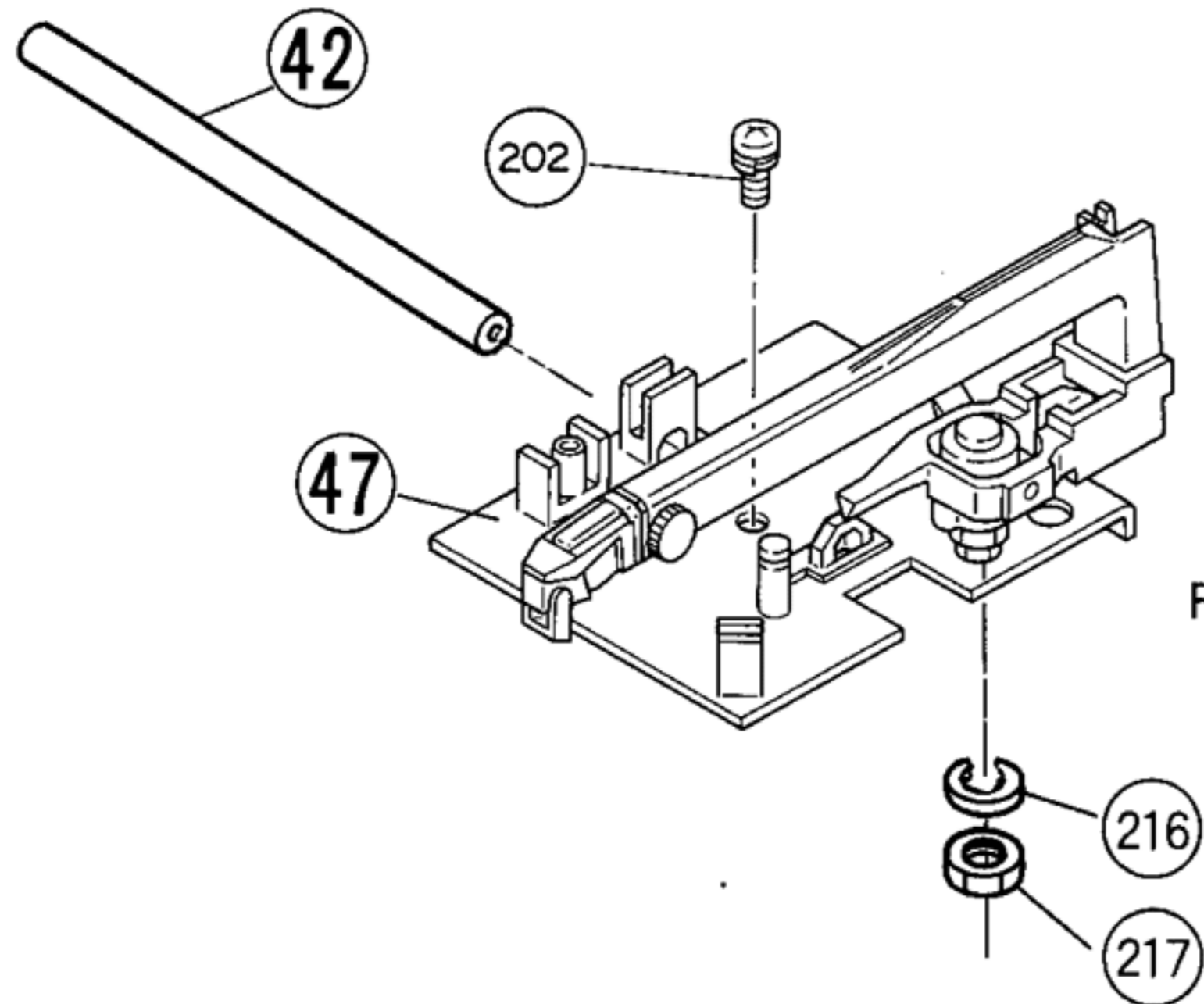

Figure 8

(D) REMOVE THE TONEARM ASSY (63) AS FOLLOWS:

1. Unsolder the five lead-wires on Phono PWB Assy (67) coming from tonearm.
2. Remove the Phono PWB Assy which is mounted to the Bracket K (47) by two Screws, (203) and (205) (Fig. 9).
3. Remove the Hexagon Nut (217) and Spring Washer (216) to remove the tonearm assy (Fig. 8).

NOTE: When the Phono PWB Assy (67) is mounted, make sure to refer to "NO TRACKING ERROR" adjustment (ADJUSTMENT D, page 6).

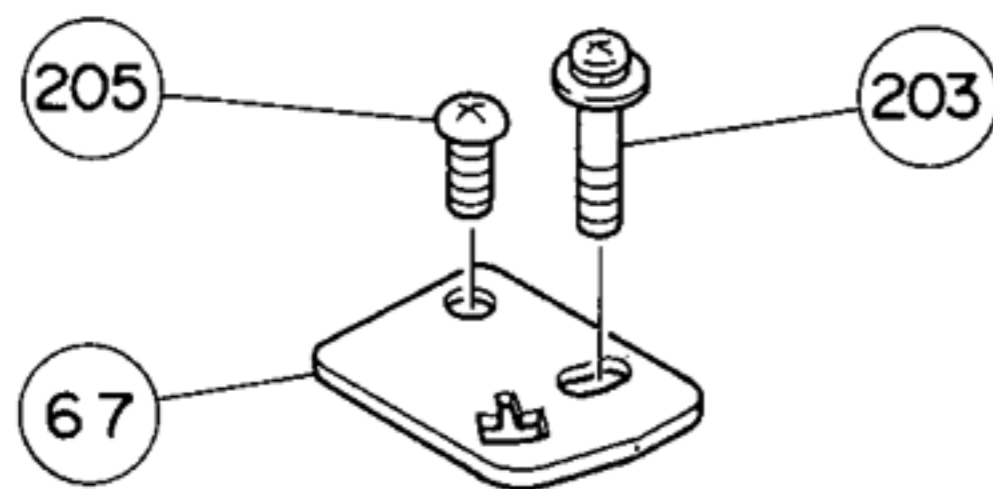

Figure 9

(E) REMOVE THE SWITCH (79) ON THE BRACKET K (47) AS FOLLOWS:

1. Remove the E type Washer (220) 2φ on Bracket K (47).
2. Remove the Washer (218) and Spring (59).
3. Remove the Bracket (48).
4. Remove the Screw (200) (Fig. 10).

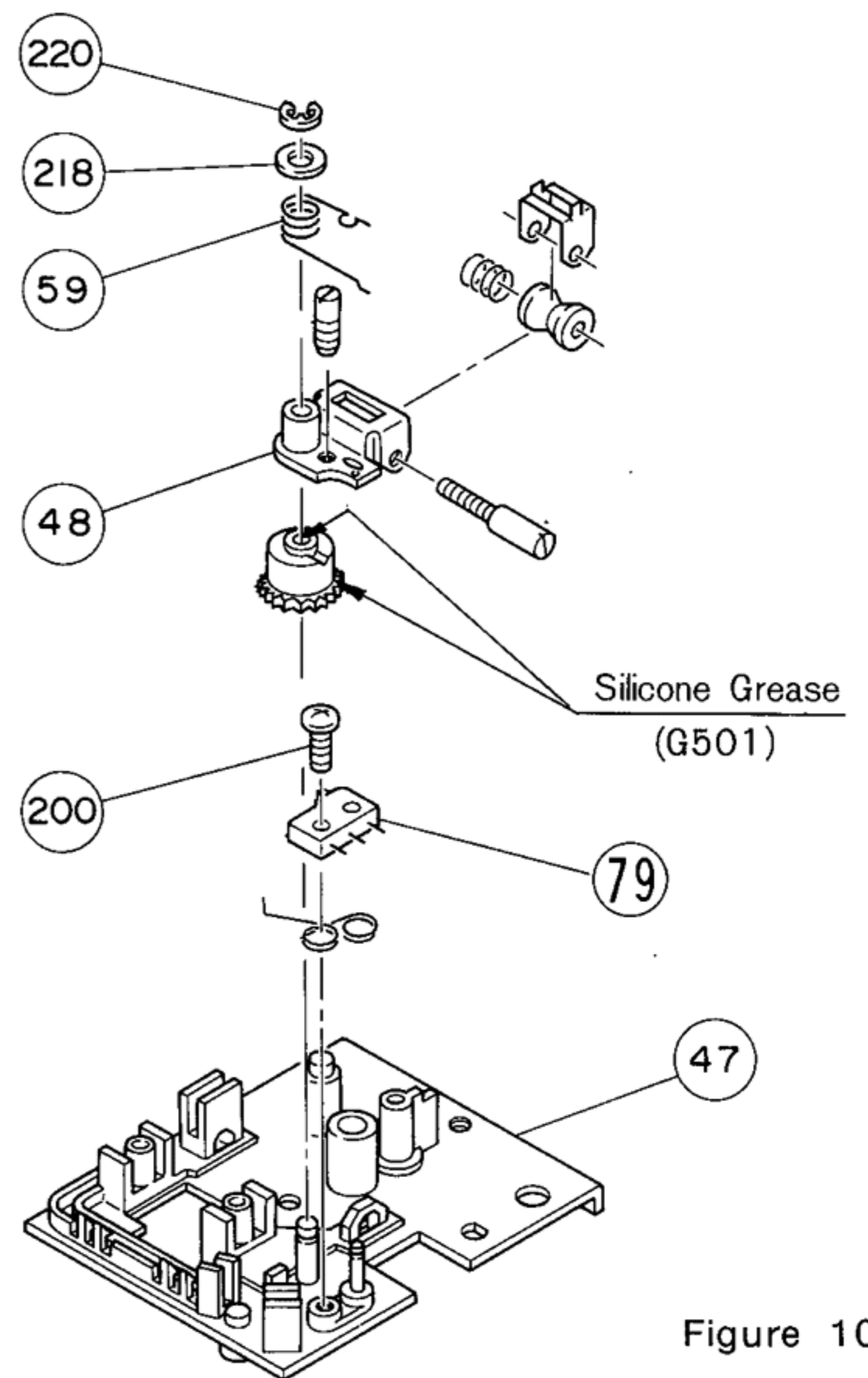

Figure 10

(F) REMOVE THE WORM GEARS, (31) AND (54), AS FOLLOWS:

1. Worm gears have been press-insert mounted. When worm gears are lifted, make sure to apply an equal force to each connecting parts (Fig. 11).
2. To lift the Worm Gear (54) remove the two Screws (222).

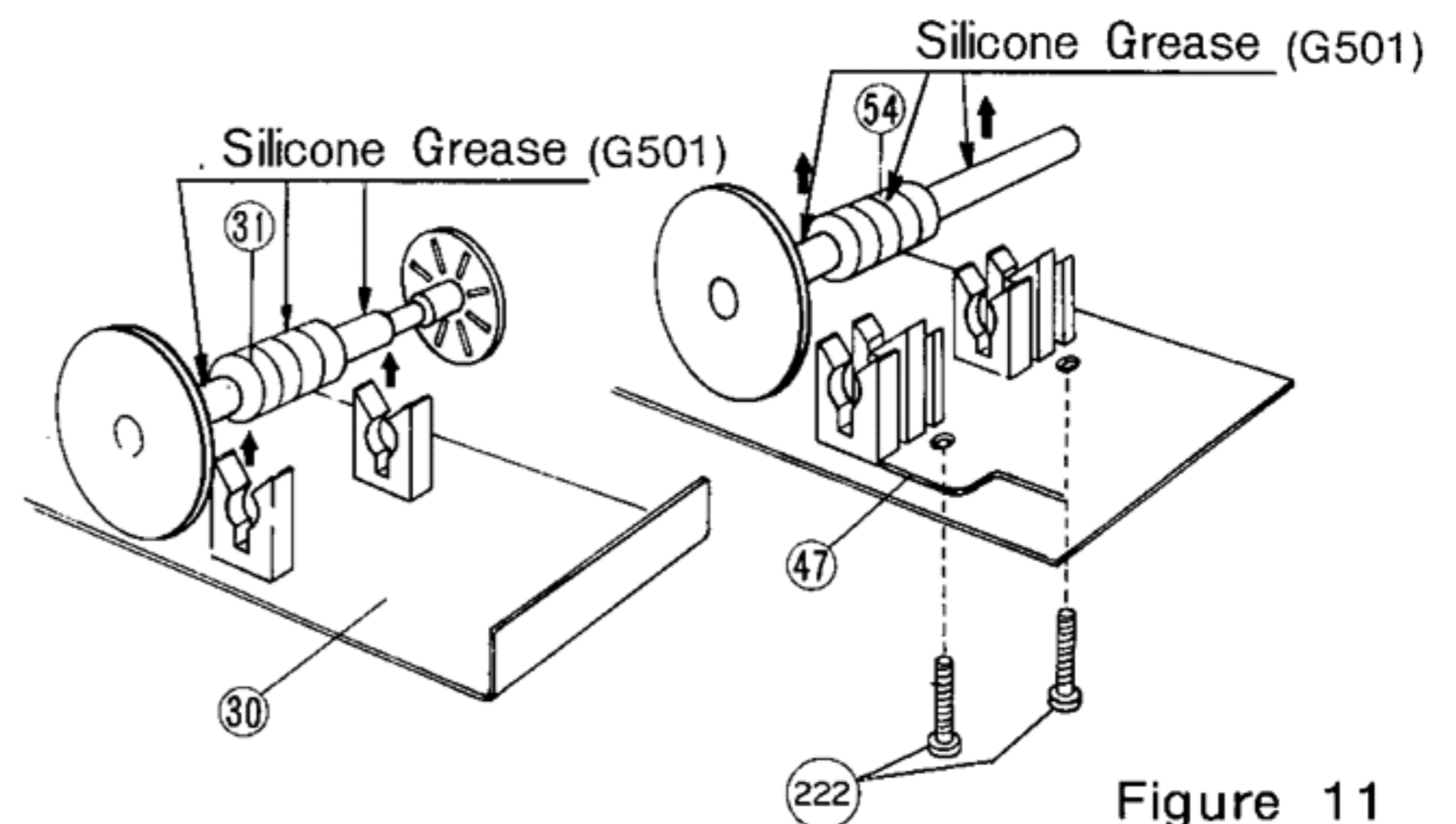

Figure 11

4. REPLACING AND REASSEMBLY INSTRUCTIONS

(A) REPLACE THE WIRE ASSY (38) AS FOLLOWS:

1. Prior to mounting, String K (38) should be rolled two turns by Wheel (35) (Fig. 12).
2. Place the Wheel (35) to the Shaft (36), and rotate the wheel clockwise until the starting point of the wire (slit on pulley) comes to the Point A (Fig. 13).
3. Rotate the wheel then counterclockwise until the point A

comes to the point B. This position will correspond to the most left possible location of Bracket K (47).

- Place the Guide (38-2) to the depressed part on case bottom (Fig. 12).

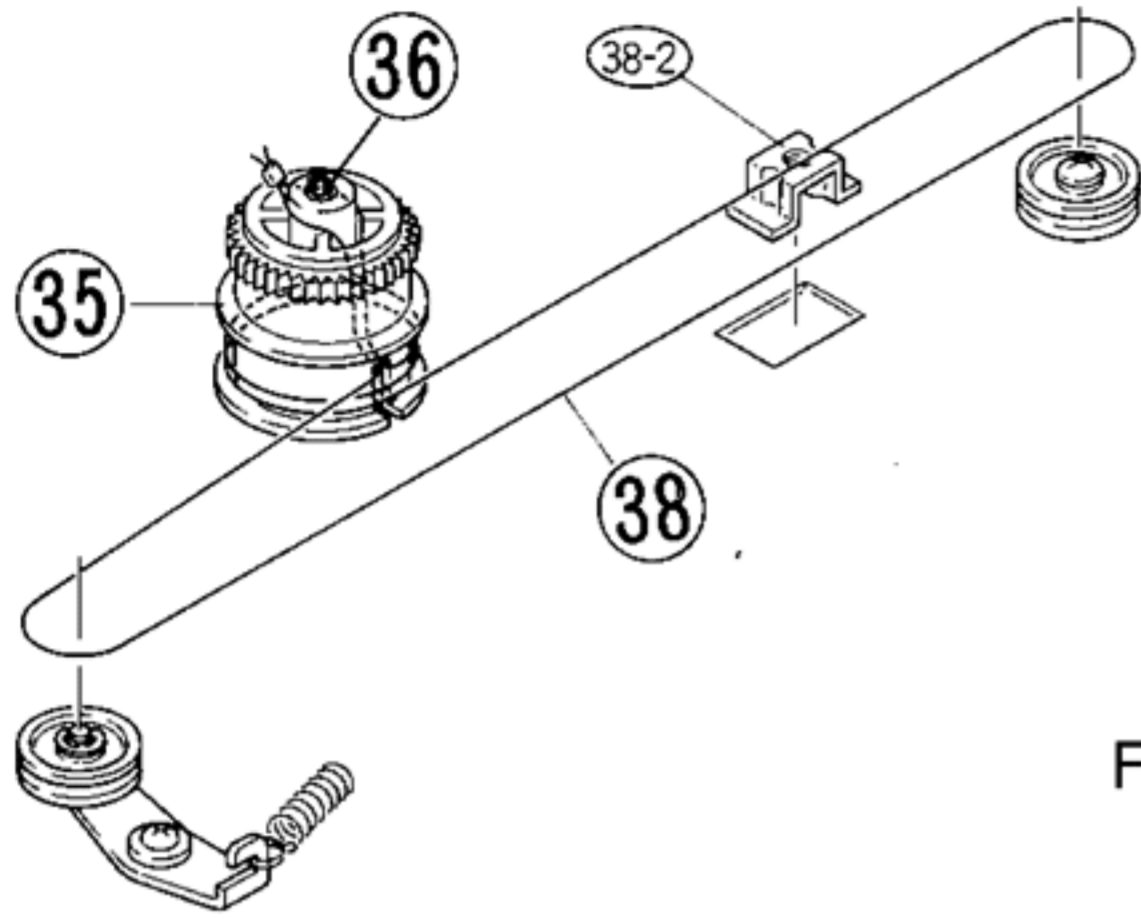

Figure 12

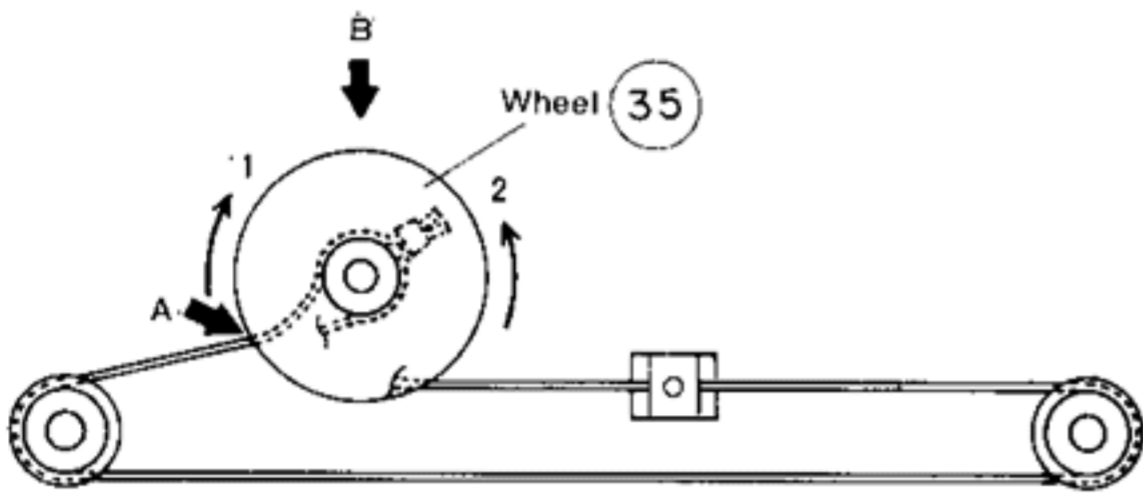

Figure 13

(B) REPLACE THE CAM (60) WITH FOLLOWING CAUTION:

When Cam (60) is replaced, make sure that the depressed part on the cam should be mounted facing with the tonearm (Fig. 14).

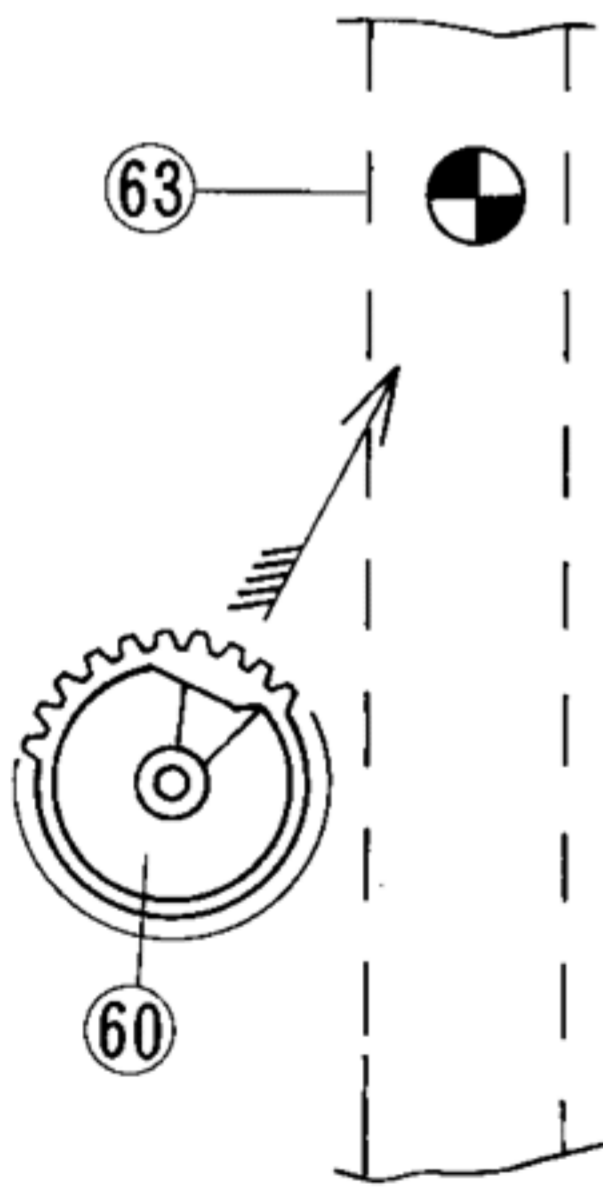

Figure 14

(C) REASSEMBLY THE WORM GEAR ASSYS, (31) AND (54), WITH FOLLOWING CAUTIONS:

1. Worm gear (54) Assy

Pressing insert the Pulley (55) to the Worm Gear (54) so that the left end of the worm gear will be on the same level as the face of the smaller circle in the pulley (Fig. 15).

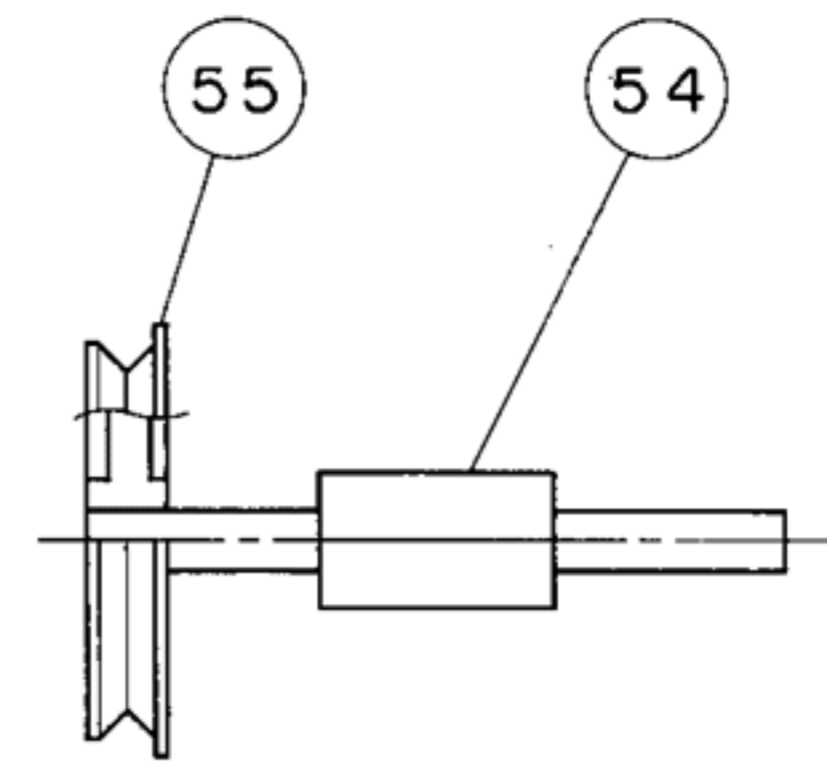

Figure 15

2. Worm gear (31) Assy

As described in Fig. 16 pressing insert the Shifter (32) and pulley to the long and short bars of Worm Gear (31) respectively. When the Shifter (32) is assembled, make sure that the left end of the bar is on the same level as the face of the shorter boss of shifter. When the Pulley (33) is assembled, press the pulley as long as it goes.

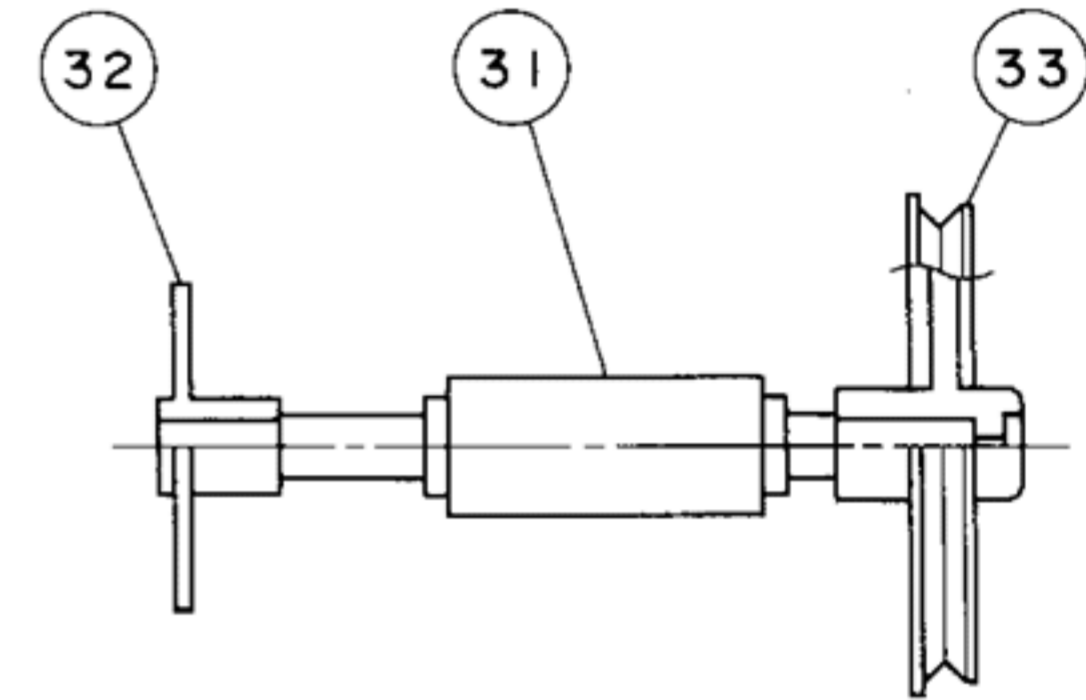

Figure 16

(D) REASSEMBLY THE MOTORS, (75) AND (76), WITH THE FOLLOWING CAUTIONS:

- When the Pulley (61 or 62) is mounted to the Motor (75 or 76), make sure to have the specified clearance between the pulley and the motor referring to Fig. 17 and Fig. 18.
- After mounting the pulley, apply quick-dry adhesive agent. We recommend "NEJI-LOCK SUPER, 1324B" for this assembly.

(E) To REASSEMBLE, use DISASSEMBLY INSTRUCTIONS in reverse.

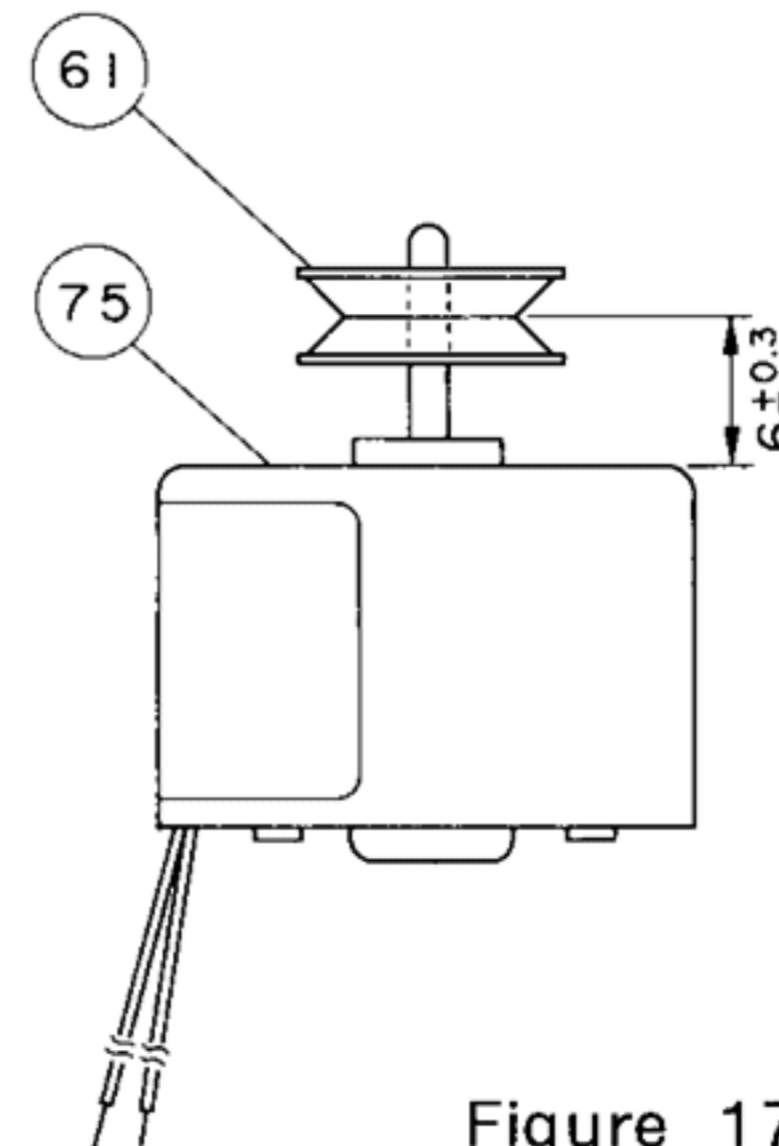

Figure 17

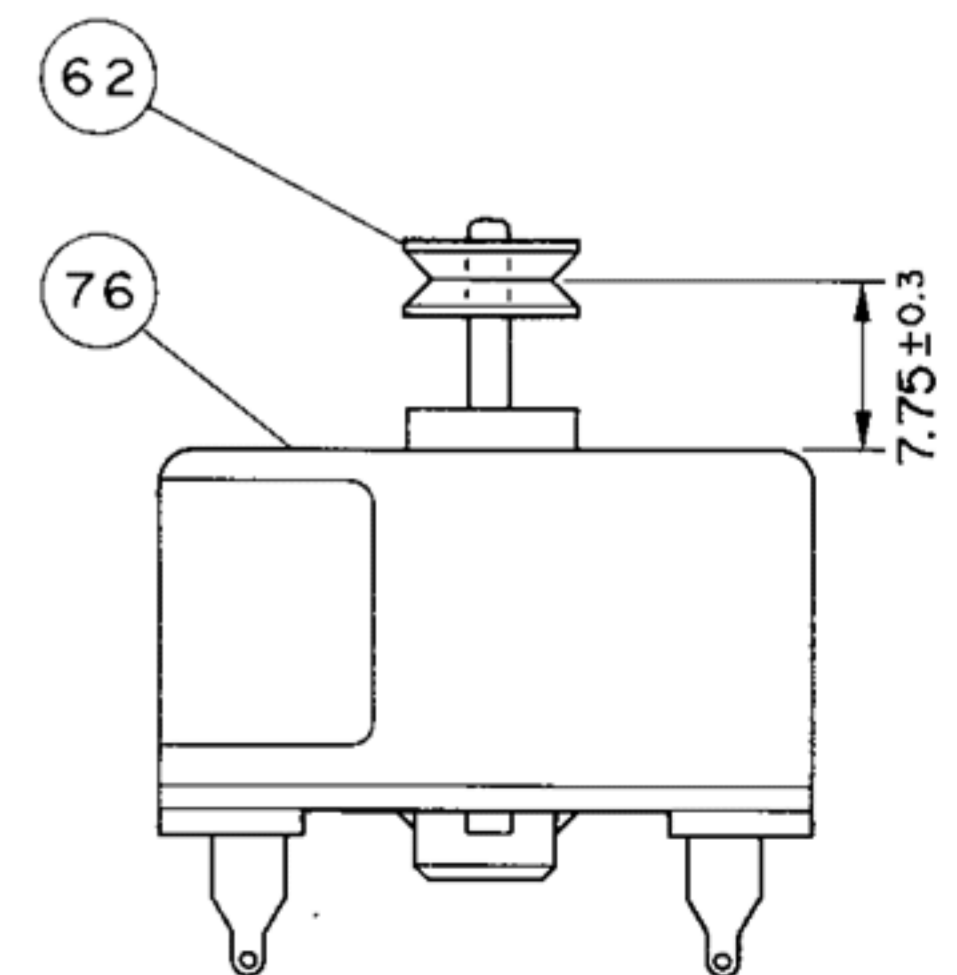

Figure 18

5. ADJUSTMENTS

(A) STYLUS POINT HEIGHT

1. Remove the case top according to DISASSEMBLY INSTRUCTIONS (B) (page 3).
2. Turn the Screw (53) described in Fig. 19 so that the clearance between stylus and turntable platter will be within 8 ~ 10 mm when the tonearm is in up position (Fig. 20).

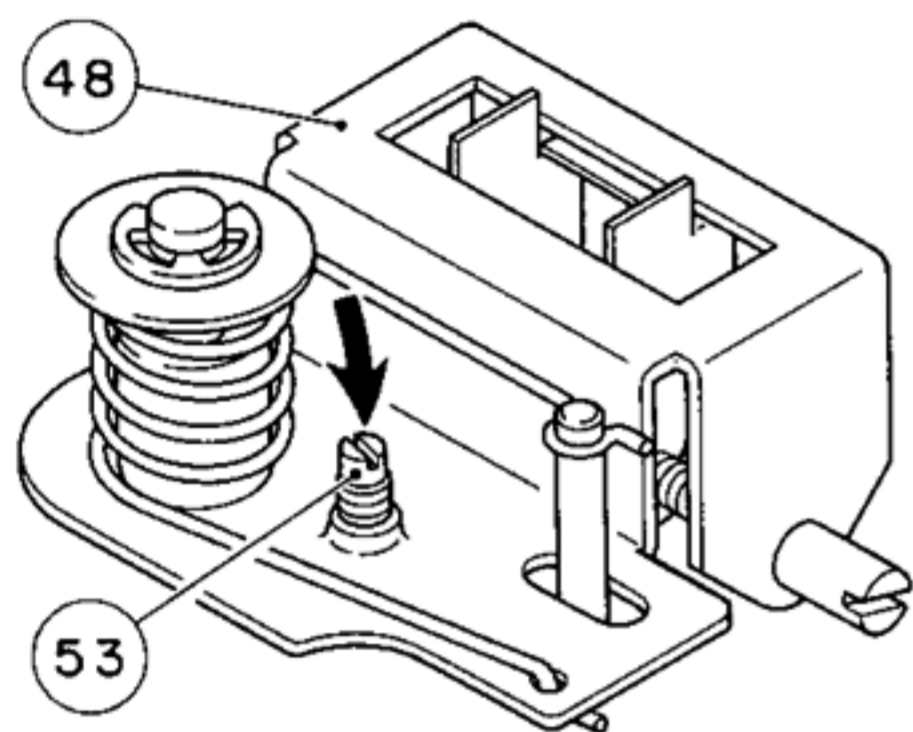

Figure 19

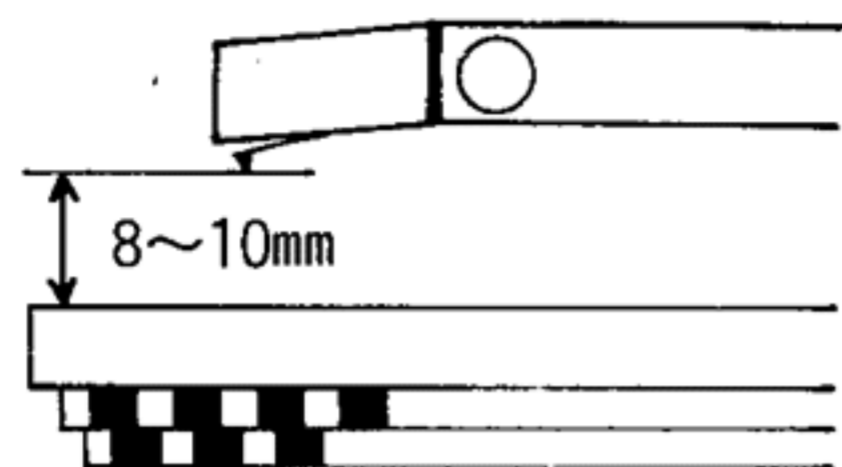

Figure 20

(B) TONEARM SETUP POSITION

1. Remove the case top according to DISASSEMBLY INSTRUCTIONS (B) (page 3).
2. Turn the Adjuster (50) described in Fig. 21 so that the tonearm will be mounted at right angles with its moving direction (Fig. 22).
3. After this adjustment, make sure to apply "NO TRACKING ERROR" adjustment (ADJUSTMENT D, page 6).

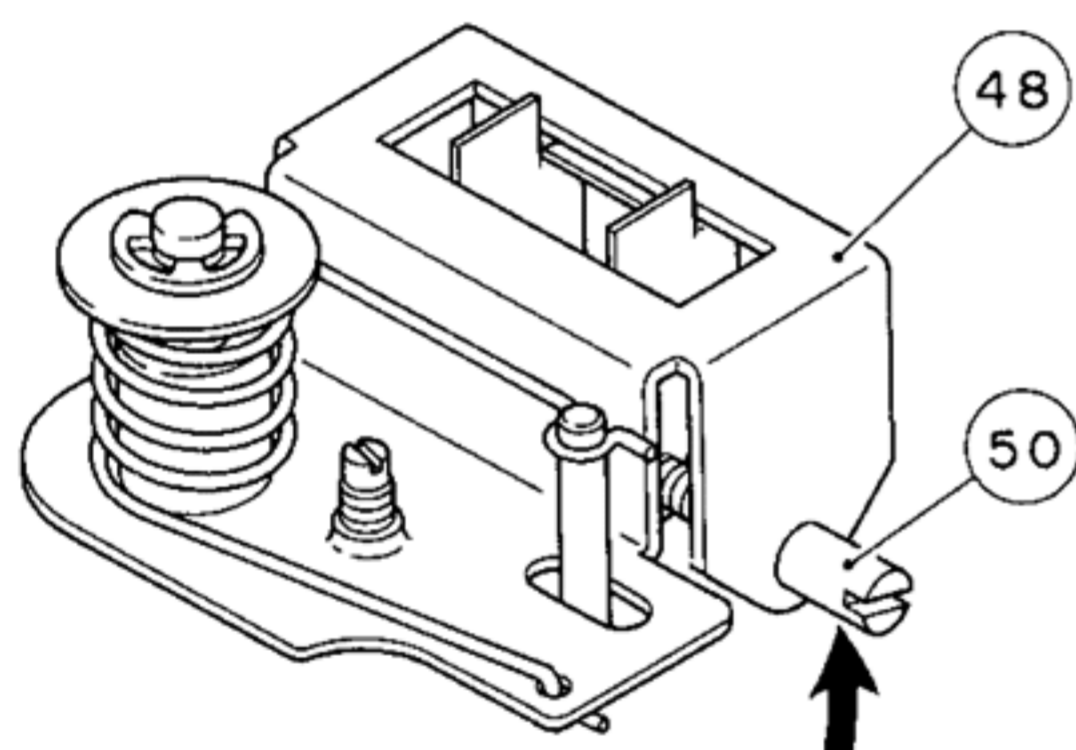

Figure 21

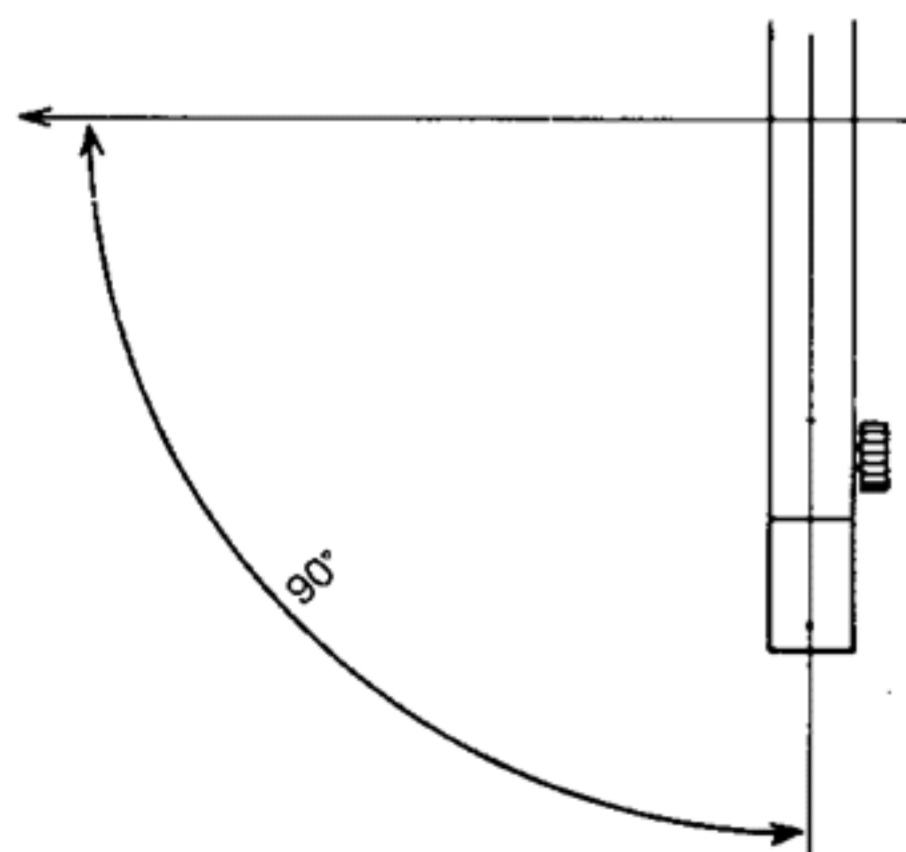

Figure 22

(C) TRACKING SENSOR SENSITIVITY

This adjustment is subject to rectifying the uneven sensitivity of Photo Interrupter (PC201) on the Phono PWB Assy (67).

NOTE: This adjustment has to be done without any direct sun shine nor any strong light.

1. Remove the case top according to DISASSEMBLY INSTRUCTIONS (B) (page 3).

2. Press the POWER button so that the unit will be switched on.
3. Connect the D.C. voltmeter between TP1 and GND terminals on Control PWB Assy (65) (Fig. 23).

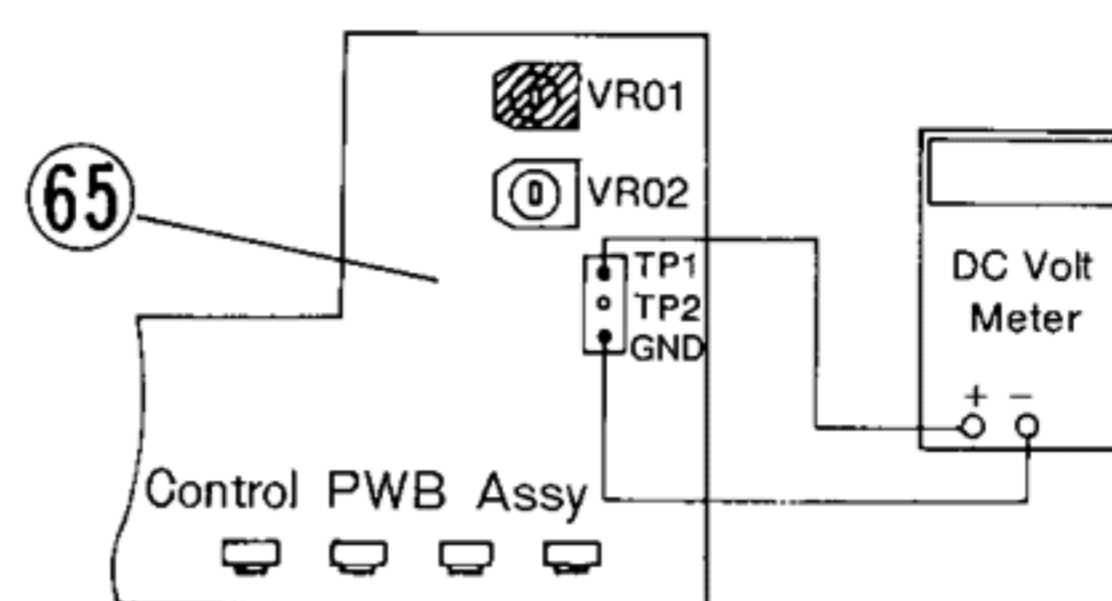

Figure 23

4. Slightly loosen the two Screws, (203) and (205), which fasten the Phono PWB Assy (67). (Fig. 24).
5. Turn the adjusting boss counterclockwise with the screwdriver (Fig. 24).

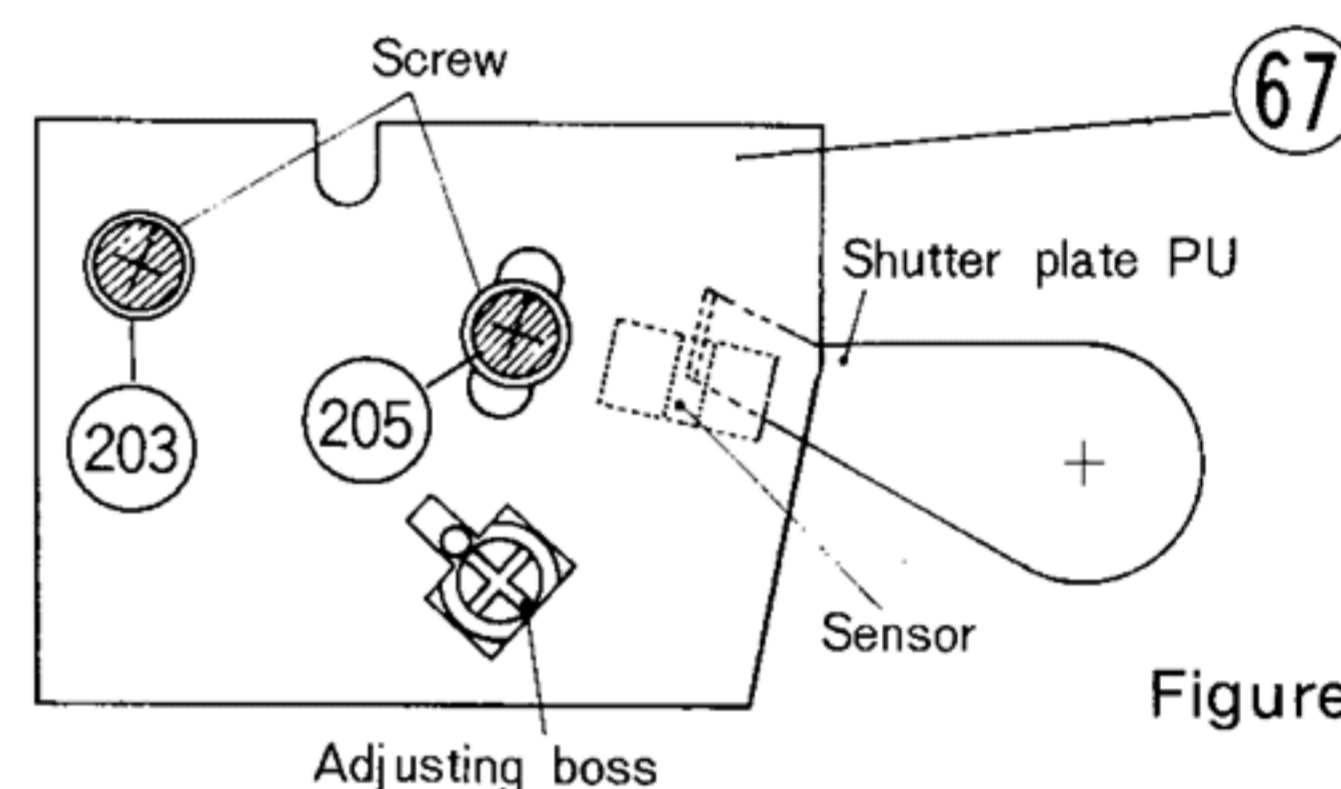

Figure 24

6. Turn the Phono PWB Assy clockwise by approximately 5° with the screw A as a center (Fig. 25).

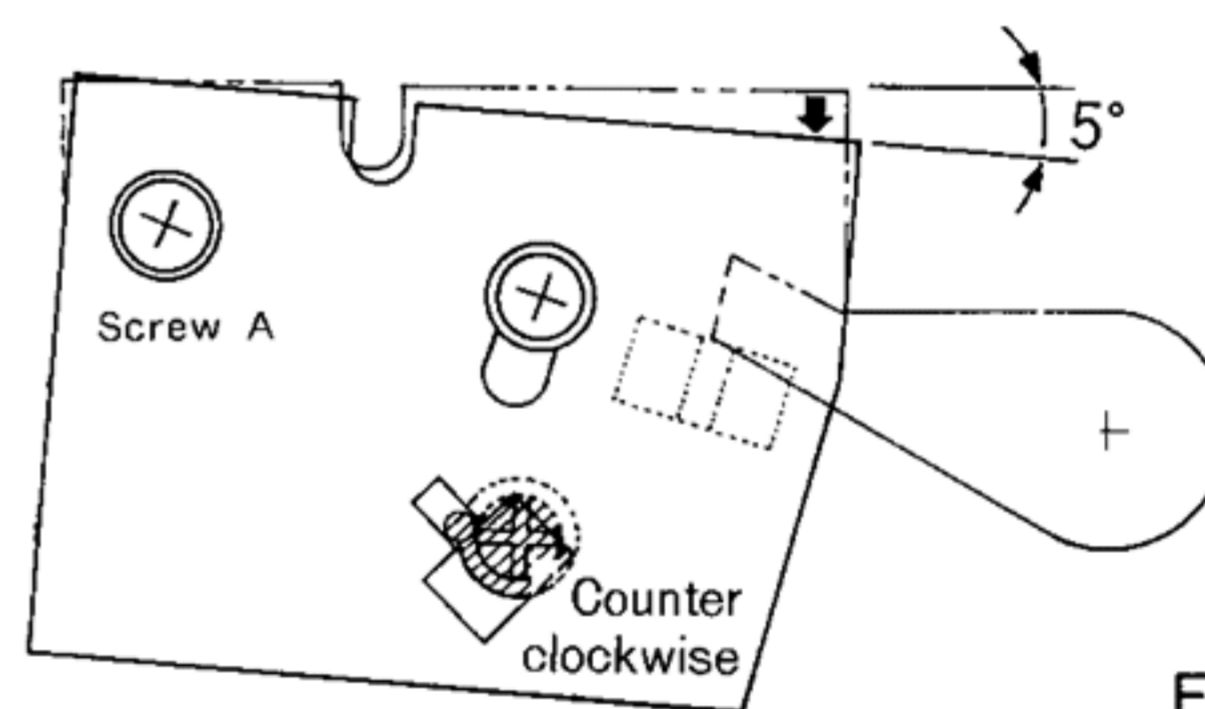

Figure 25

7. Make sure that the sensor gets enough light not being obstructed by shutter plate.
8. Turn the Variable Resistor (VR01) with a small size slotted-head screwdriver so that the voltmeter shows -3.9 ~ -4.1 volts.
9. After the above adjustment, make sure to apply "NO TRACKING ERROR" and "STYLUS SET-DOWN POSITION" adjustments (ADJUSTMENTS D AND E, page 6 and 7).

(D) NO TRACKING ERROR

NOTE: This adjustment has to be done without any direct sun shine nor any strong light.

1. Remove the case top according to DISASSEMBLY INSTRUCTIONS (B) (page 3).
2. Press the POWER button so that the unit will be switched on.

3. Connect the D.C. voltmeter between TP1 and GND terminals on Control PWB Assy (65) (Fig. 23).
4. Slightly loosen the two Screws, (203) and (205), which fasten the Phono PWB Assy (Fig. 24).
5. Turn the adjusting boss with a screwdriver so that the voltmeter shows $-1.6 \sim -2.0$ volts.
6. Disconnect the D.C. voltmeter and re-connect it between TP2 and GND terminals on Control PWB Assy (Fig. 26).

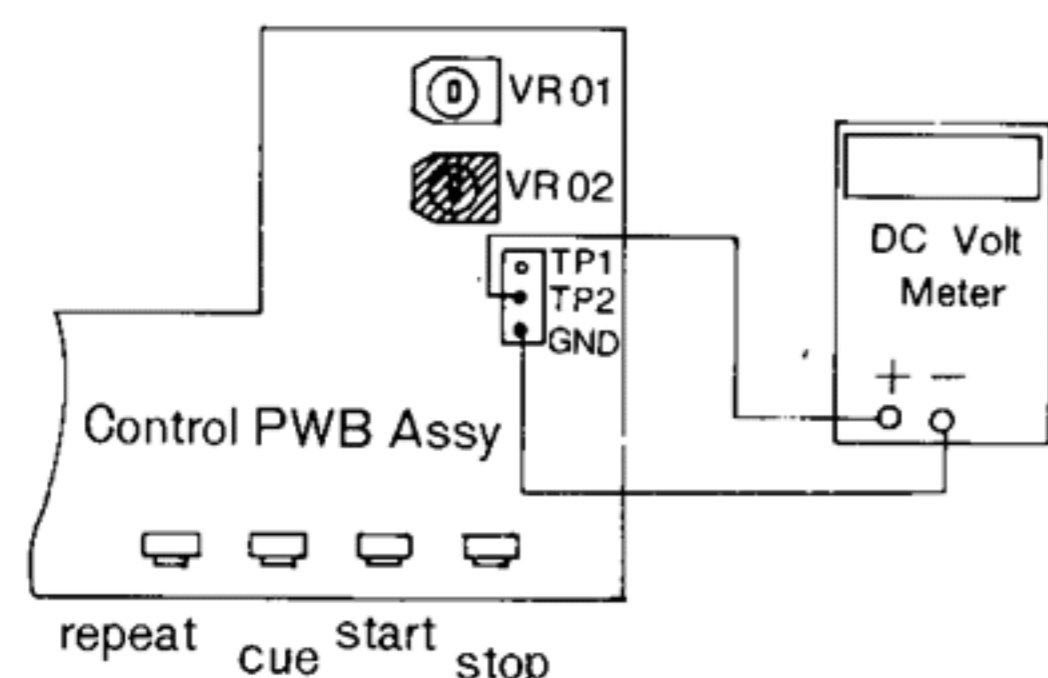

Figure 26

7. Without placing the turntable platter, press the START button so that the tonearm starts moving.
8. Press the CUE button so that the tonearm lifts after stylus set-down.
9. Turn the Variable Resistor (VR02) with a screwdriver so that the voltmeter shows $-1.9 \sim -2.1$ volts.
10. Press the CUE button so that the tonearm descends and press the CUT button for tonearm return to its rest.
11. After above adjustment, make sure to apply "STYLUS SET-DOWN" adjustment (ADJUSTMENT E, page 7).

(E) STYLUS SET-DOWN POSITION

1. Remove the case top according to DISASSEMBLY INSTRUCTIONS (B) (page 3).
2. Press the POWER button so that the unit will be switched on.
3. Place the turntable platter and mat.
4. Use the first face of NEC test record ES-1008 for this adjustment. Press the PLAY button; turntable starts rotation, the tonearm will move and descend onto a record.
5. Turn the adjusting pin described in Fig. 27 so that the stylus set-down position will be counted between 15 and 17 points.
6. Using the second face of the test record ES-1008 make sure that the automatic return position will be counted between 19 and 22 points.

NOTE: After the above steps, no adjustment for 17 cm records is required. However, to settle the specified counting position by the first time adjustment may be difficult. Apply several times adjustments to confirm the above specified position.

(F) PITCH ADJUSTMENT OF STYLUS SET-DOWN POSITION

After fundamental adjustment mentioned above (E), pitch adjustment of stylus set-down position is available without removing the case top.

1. Place the unit upside down on a suitable bench.
2. Stylus set-down position can be adjusted by rotating the cam through the hole which is marked in Fig. 2 with a slotted-head screwdriver.
3. Counterclockwise turn moves the set-down position inward; clockwise turn moves the set-down position outward.

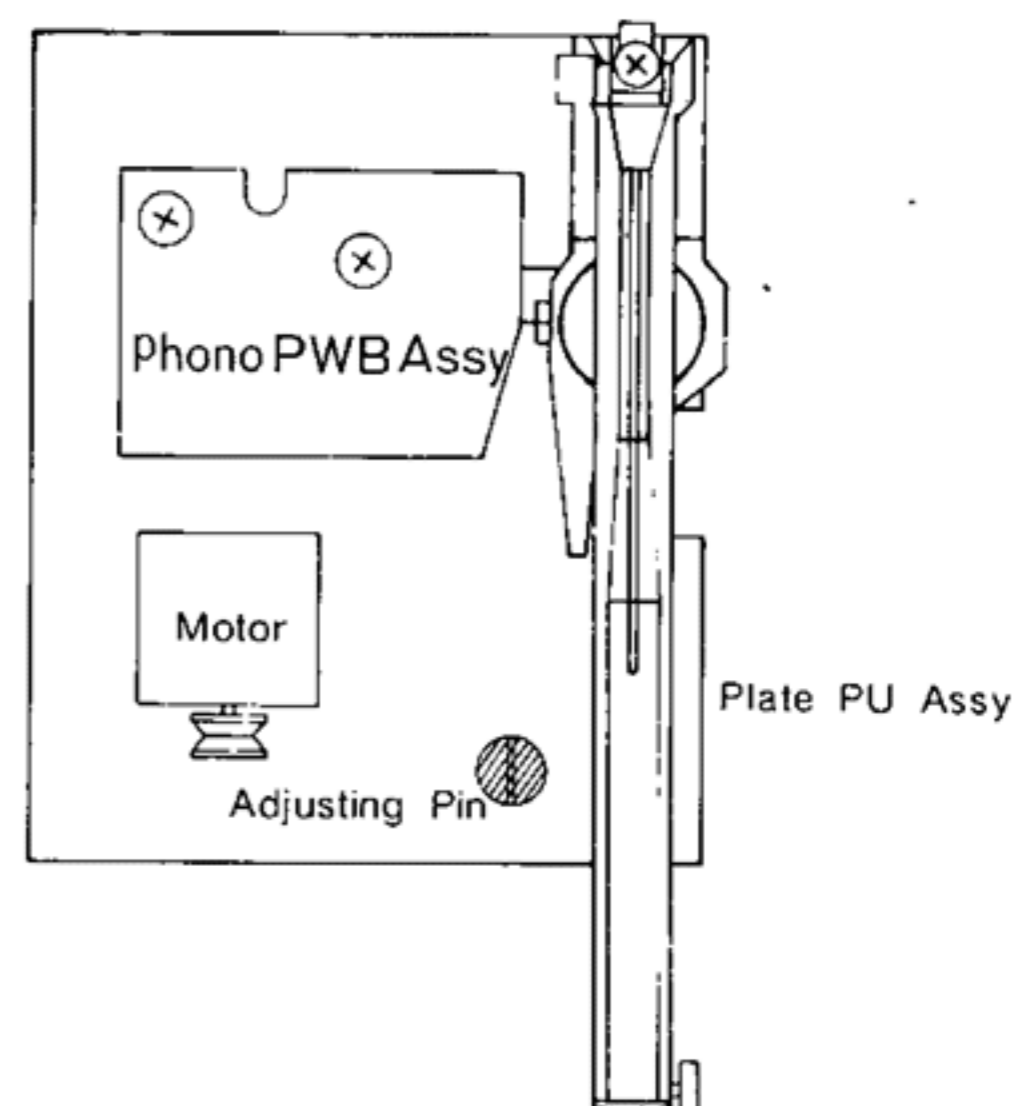

Figure 27

6. TROUBLESHOOTING

(A) THE STROBE LIGHT DOES NOT TURN ON

Measure the voltage between 4 and 5 terminals on Power PWB Assy (70) with A.C. voltmeter.

- * Local voltage is supplied: (R501), Neon Lamp (71-2) or Lead-wire is defective.
- * Different voltage from local one or no voltage is supplied: Power Supply Cord (73), Power Switch (SW501) or Fuse (70-2) is defective.

(B) THE RECORD SIZE SEARCHER LIGHT DOES NOT TURN ON

Measure the voltage between GND and each ± 9 volts terminals, (J10) and (J12), on Control PWB Assy (65) with D.C. voltmeter.

- * Approx. $\pm 9V$ is supplied: Measure the voltage between 1 and 2 terminals on Position PWB (69-1) with D.C. voltmeter.
 - * Approx. 18V is supplied: Lamp (78) or Lead-wire is defective.
 - * Too short voltage is supplied: Cord Assy 6P (69-2) or connector is defective.
- * Quite different voltage from +9V is supplied: (Q01), (Q02) or (Q03) is defective.
- * Quite different voltage from -9V is supplied: (Q04), (Q05) or (Q06) is defective.

(C) THE TURNTABLE DOES NOT START ROTATION AFTER PLACING THE RECORD

Check to see that the base-voltage at (Q19) is approx. +9V when tonearm returns to its rest upon STOP button being pressed, and the voltage is lowered by approx. 0.6V upon PLAY button being pressed.

- * Yes: (Q33), Cord Assy 7P (65-3) or Direct-drive Motor (77) is defective.
- * No: (IC03) or (R44) is defective.

**(D) STYLUS SET-DOWN POSITION IS NOT
CORRESPONDING TO THE RECORD SIZE**

Check to see that the collector voltage at (Q24) against GND will be changed from approx. +9V to approx. 0V when the light through the slit on the turntable platter reaches to the Photo Transistor (Q301) on Record PWB Assy (68).

NOTE: Make sure that no outside light will be reached to photo transistor during the measurement. Use D.C. voltmeter or oscilloscope for the measurement.

- * No change: Photo Transistor (Q301), Cord Assy 6P (69-2) or (Q24) is defective.
- * Changing: (IC03) is defective.

NOTE: After replacement the part, the adjustment according to ADJUSTMENT (E) on page 7 should be applied.

**(E) TONEARM MOVES TOO INSIDE UPON PLAY
BUTTON BEING PRESSED**

Check to see that the collector voltage at (PC401) against GND with the oscilloscope will be changed by 8 pulses per one turn (from approx. +9V to approx. 0V) according to the turn of Shifter (32) which has 8 slits.

- * No change or small number of pulse: (PC401), Cord Assy 6P (69-2), (Q21), (Q22) or (Q23) is defective.
- * Changing: (IC03) is defective.

INFORMATION: The (IC03) acknowledges that the tonearm moves to the stylus set-down and/or return position when the number of the pulse from the start point corresponds to

the number programmed beforehand. After the acknowledgement, (IC03) will supply the necessary signal for various movement according to the position of tonearm.

(F) NO SOUND FROM THE LOUD SPEAKER

Measure the value of resistor between Output Shield Wire (74) and its shielded part.

- * 0 ohm: The Circuit (65) or (67) is shortage or muting relay is defective.
- * Approx. ∞ ohm: The dead circuit or defective cartridge.

(G) NO MUTING WORKS UPON STYLUS UP ACTION

Check to see that the base-voltage at (Q17) against GND is approx. +9V when tonearm is in up position upon CUE button being pressed, and the voltage is lowered by approx. 0.6V upon CUE button being pressed again.

- * Yes: (Q17), (Q32) or muting relay is defective.
- * No: (IC03) is defective.

**(H) THE TONEARM MOVES LEFT-WARD UPON UP
AND DOWN ACTIONS**

Apply ADJUSTMENTS (C), (D) and (E) (page 6 and 7).

**(I) THE STYLUS KICKS THE RECORD UPON ITS UP
ACTION**

Apply ADJUSTMENTS (C), (D) and (E) (page 6 and 7).

NOTE: The extent up to 0.2 mm fall within the specification settled. If the pitch of the record groove increases, this figure tends to increase.

7. SCHEMATIC DIAGRAM (Phono Motor)

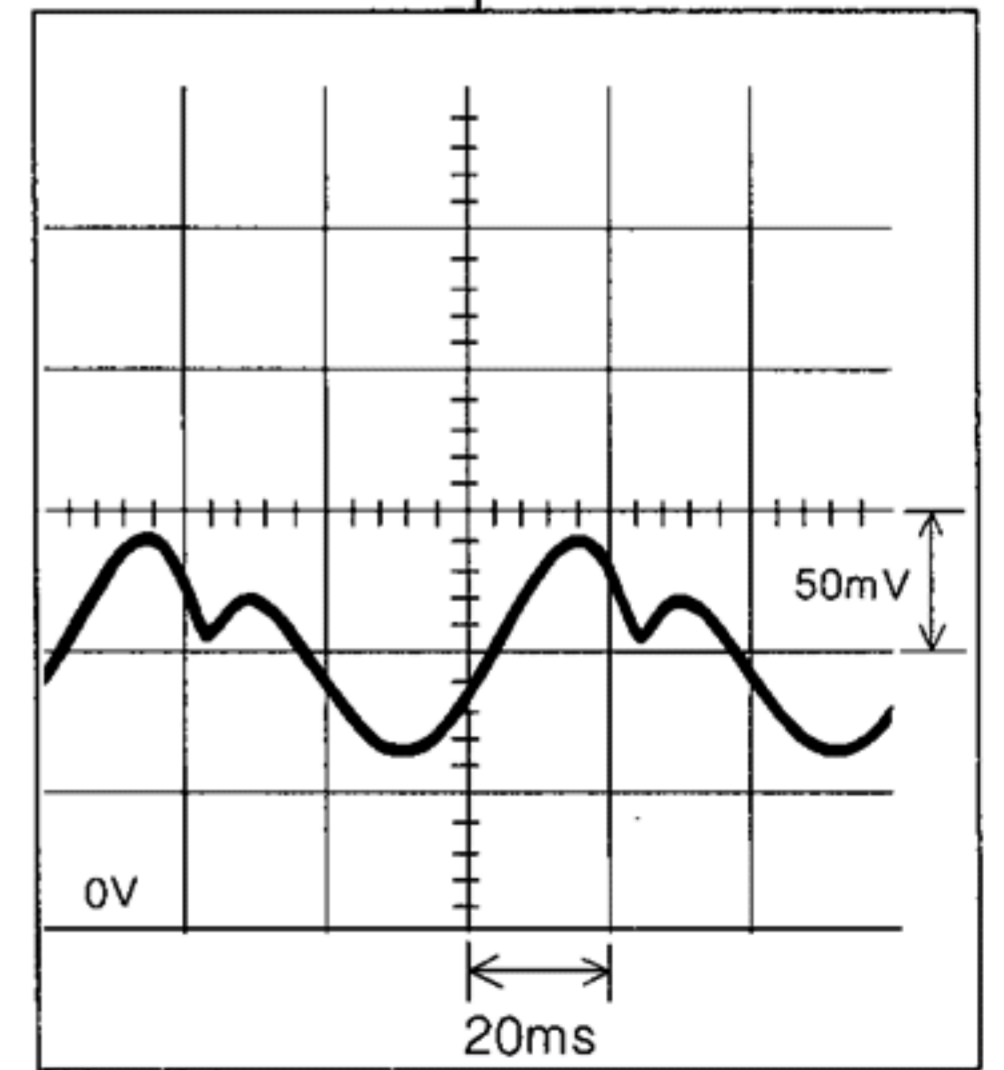
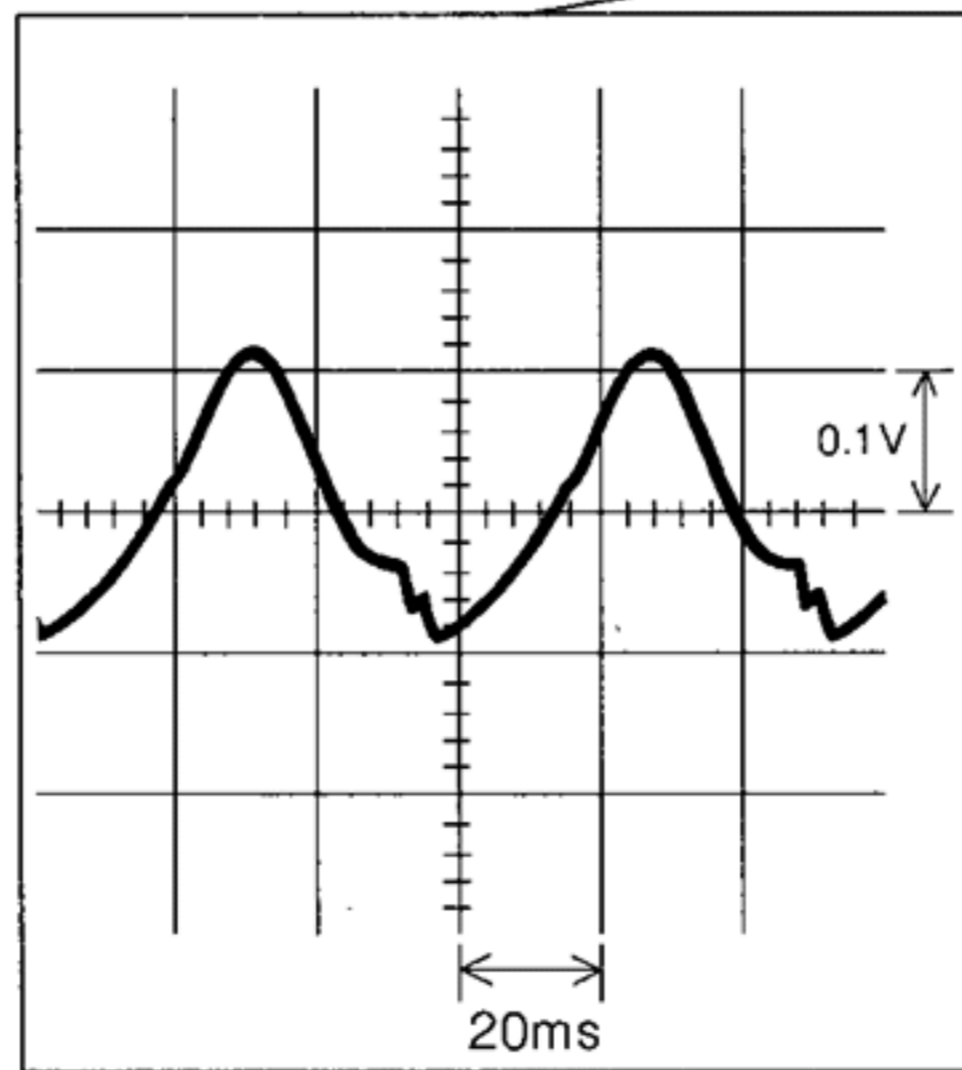
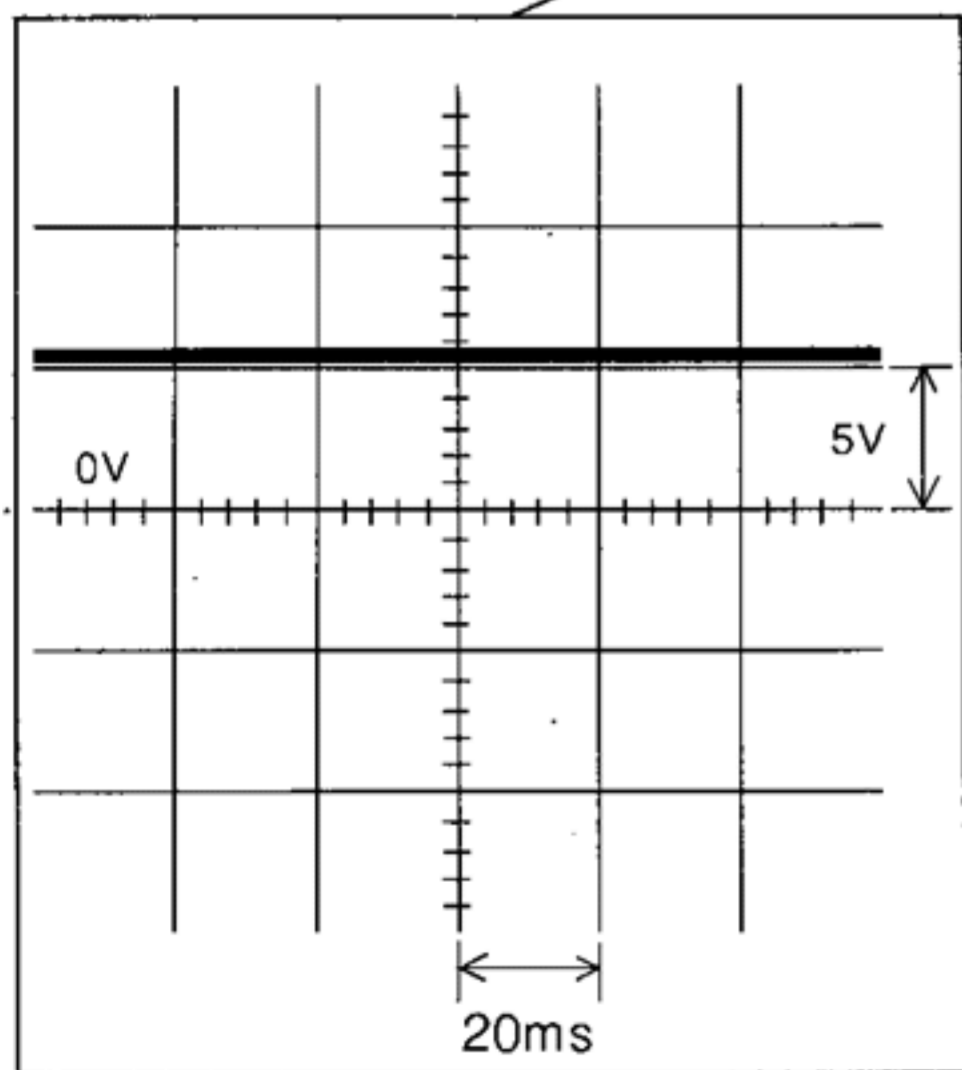
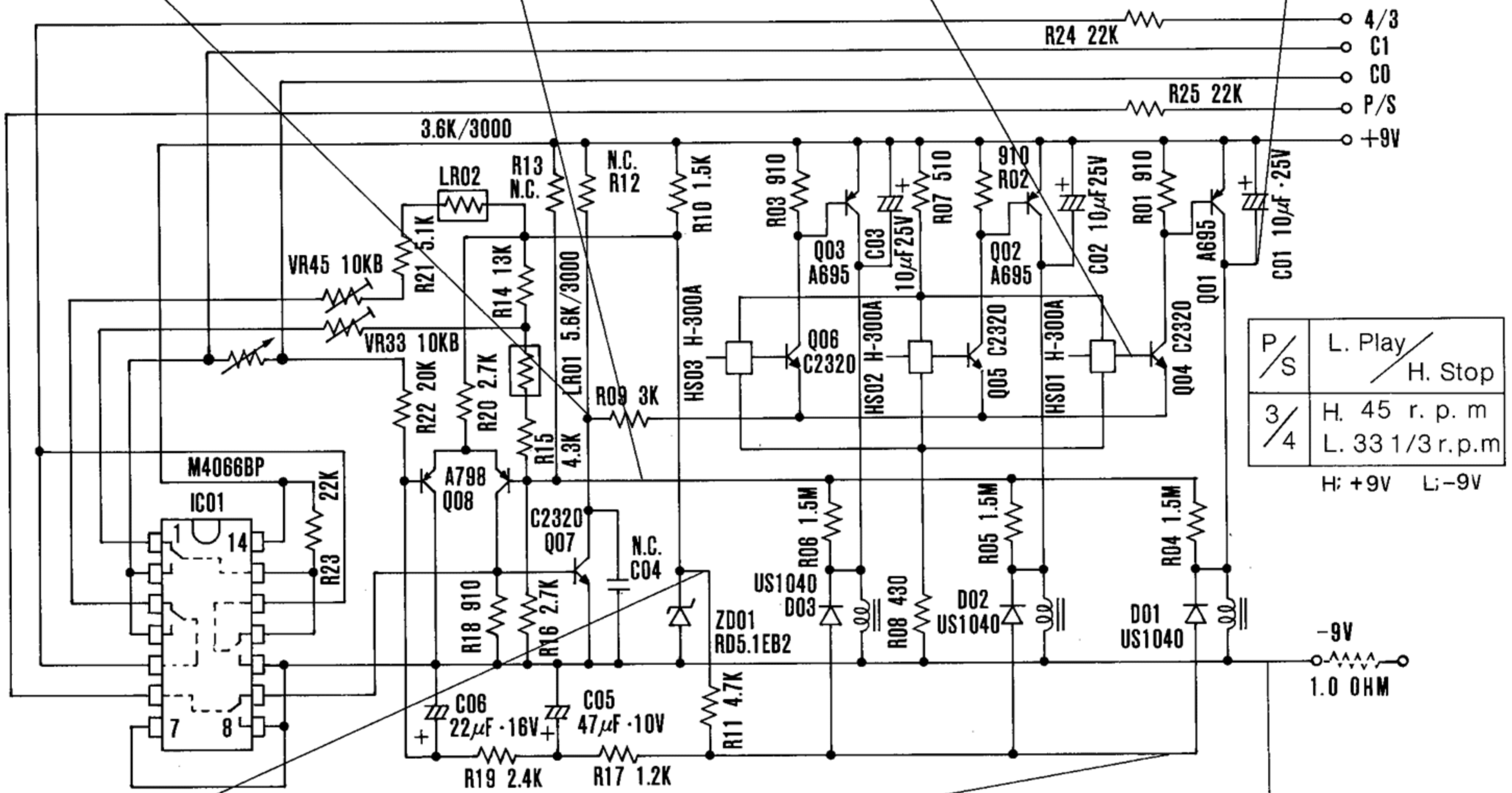
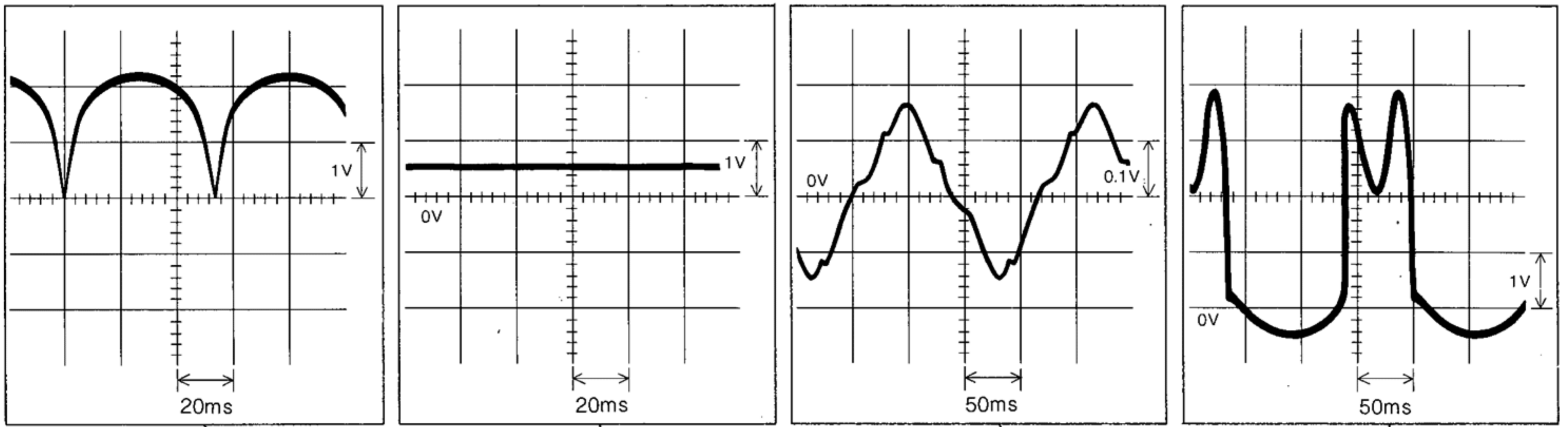

8. WIRING DIAGRAMS

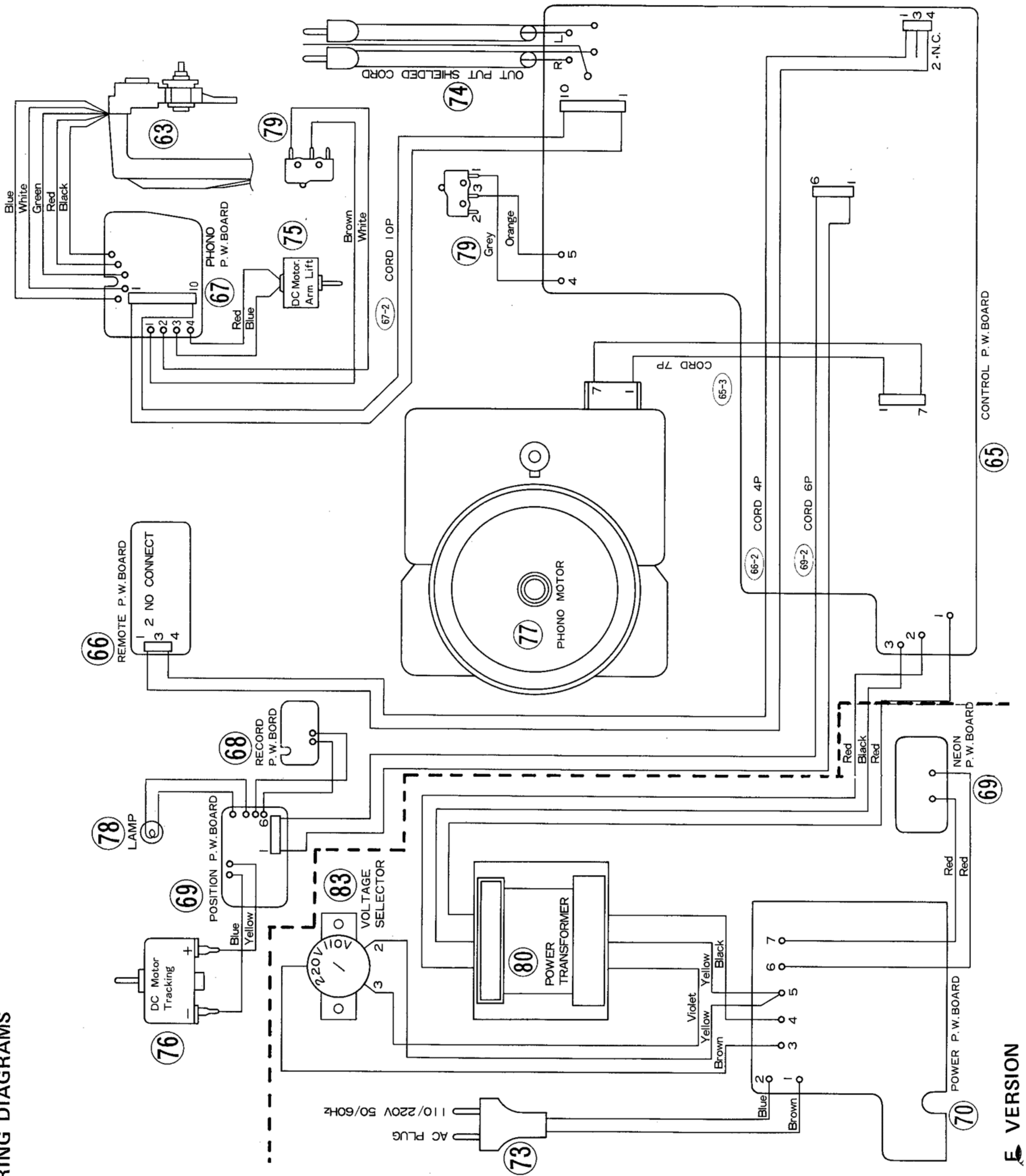

E VERSION

N VERSION

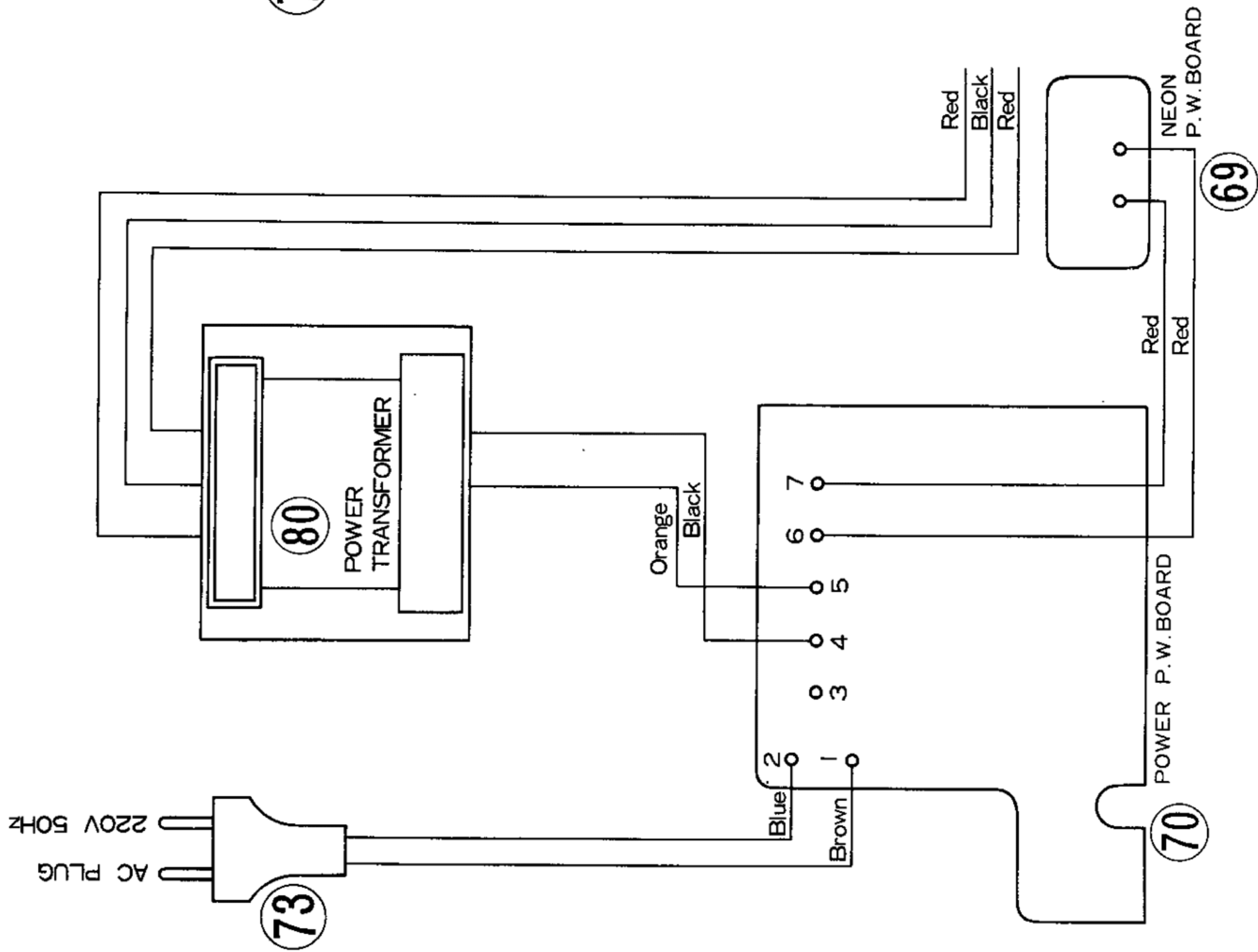

T/A VERSION

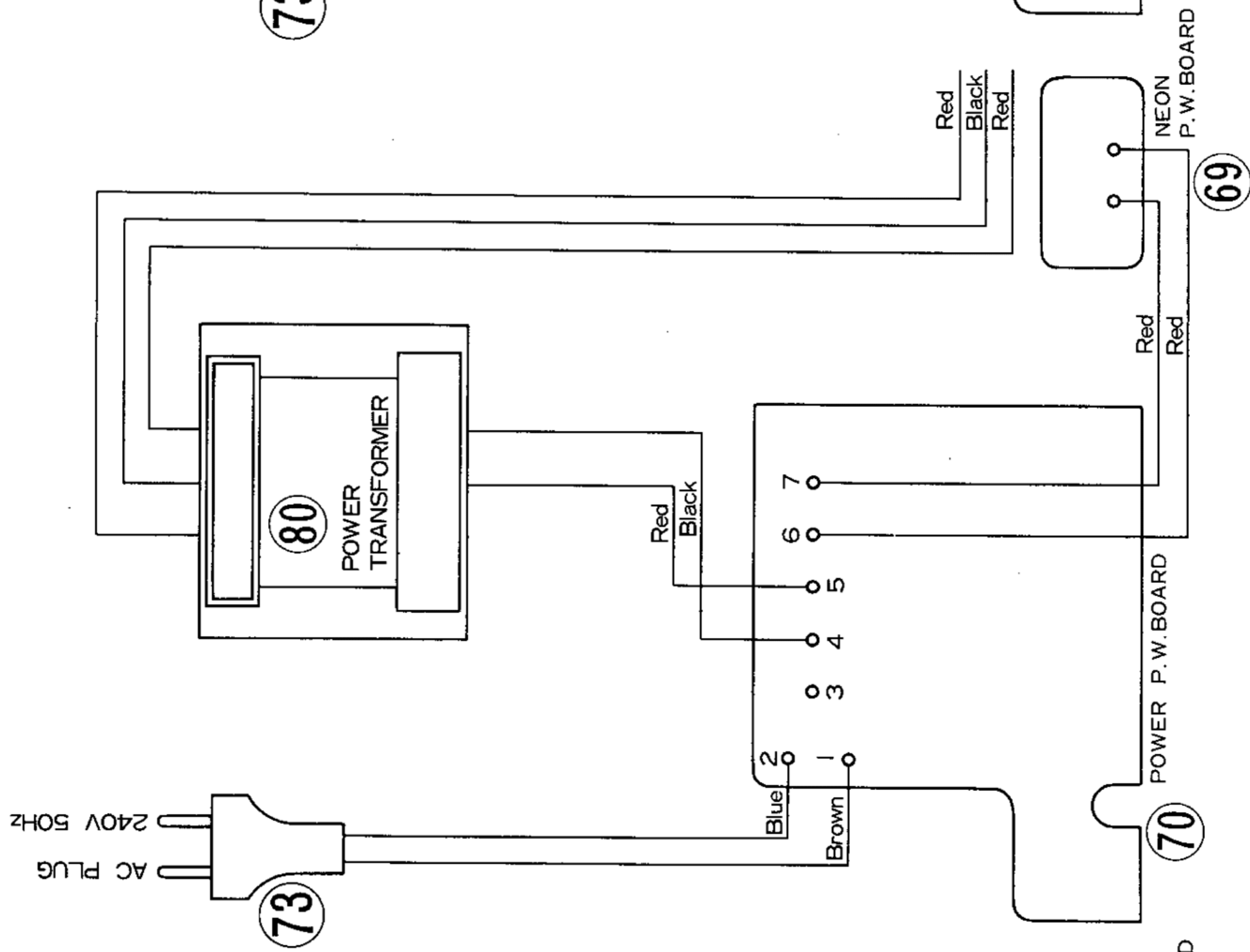

U/C VERSION

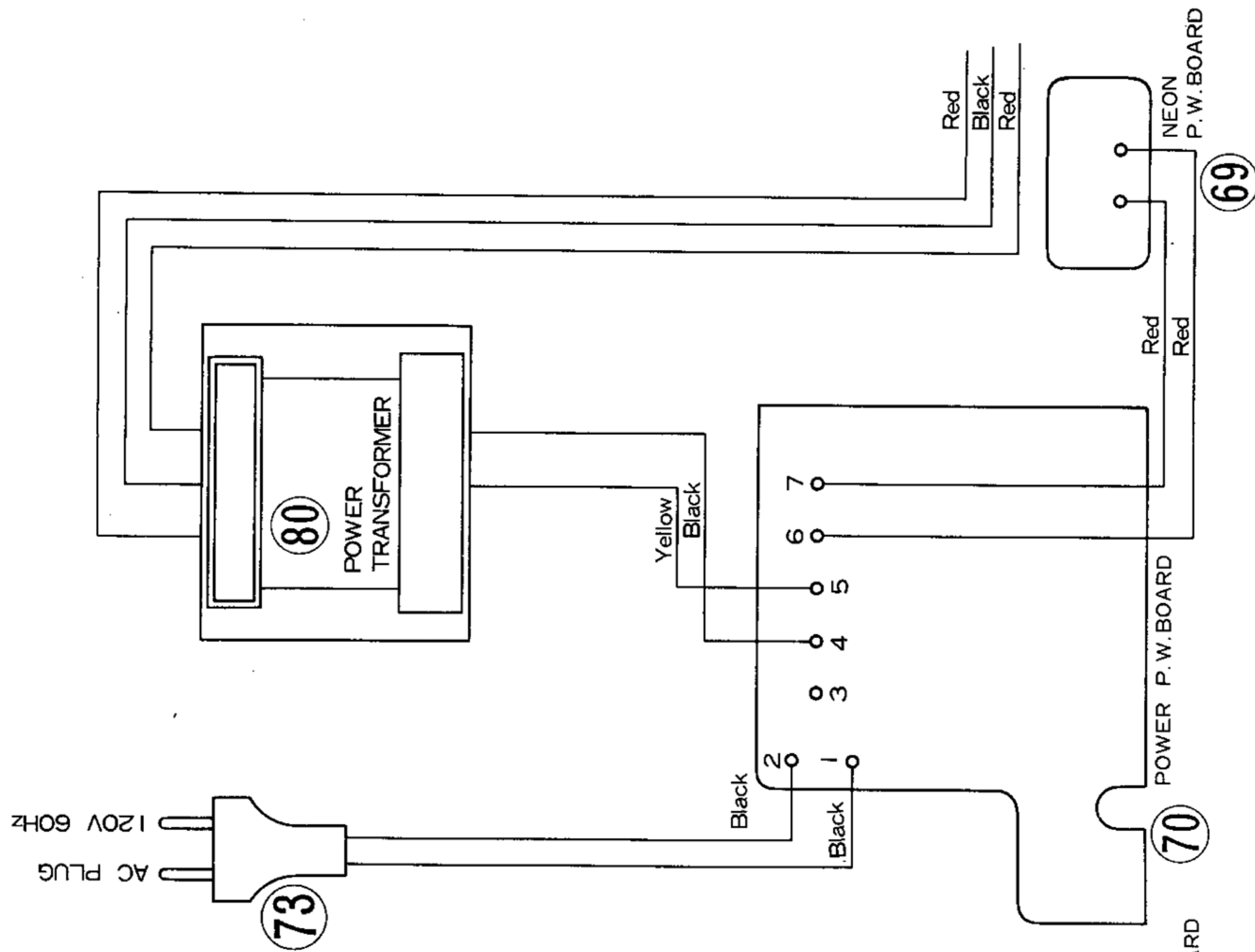

9. CONTROLLER CIRCUIT DIAGRAMS



N VERSION

T VERSION

A VERSION

U/C VERSION

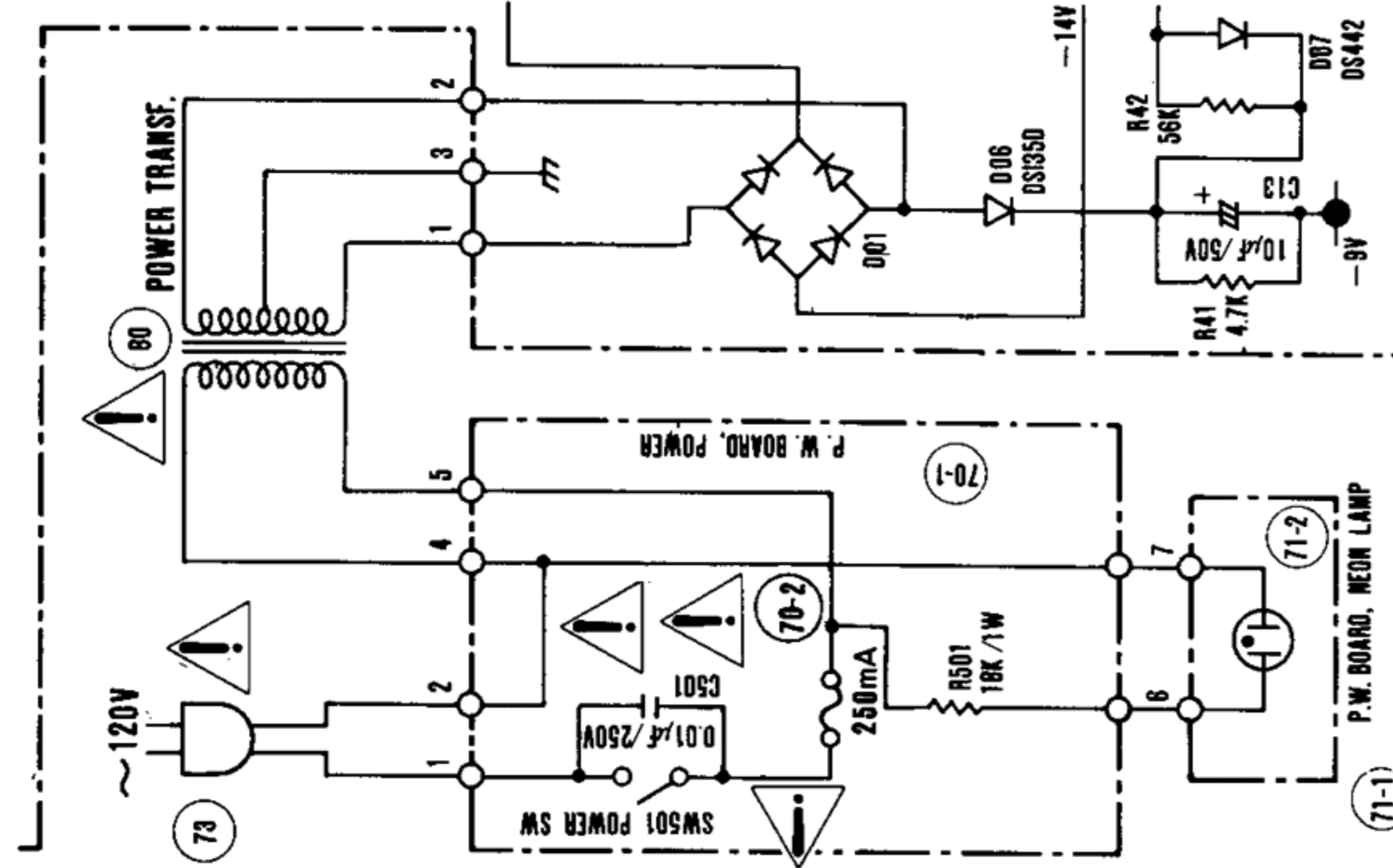
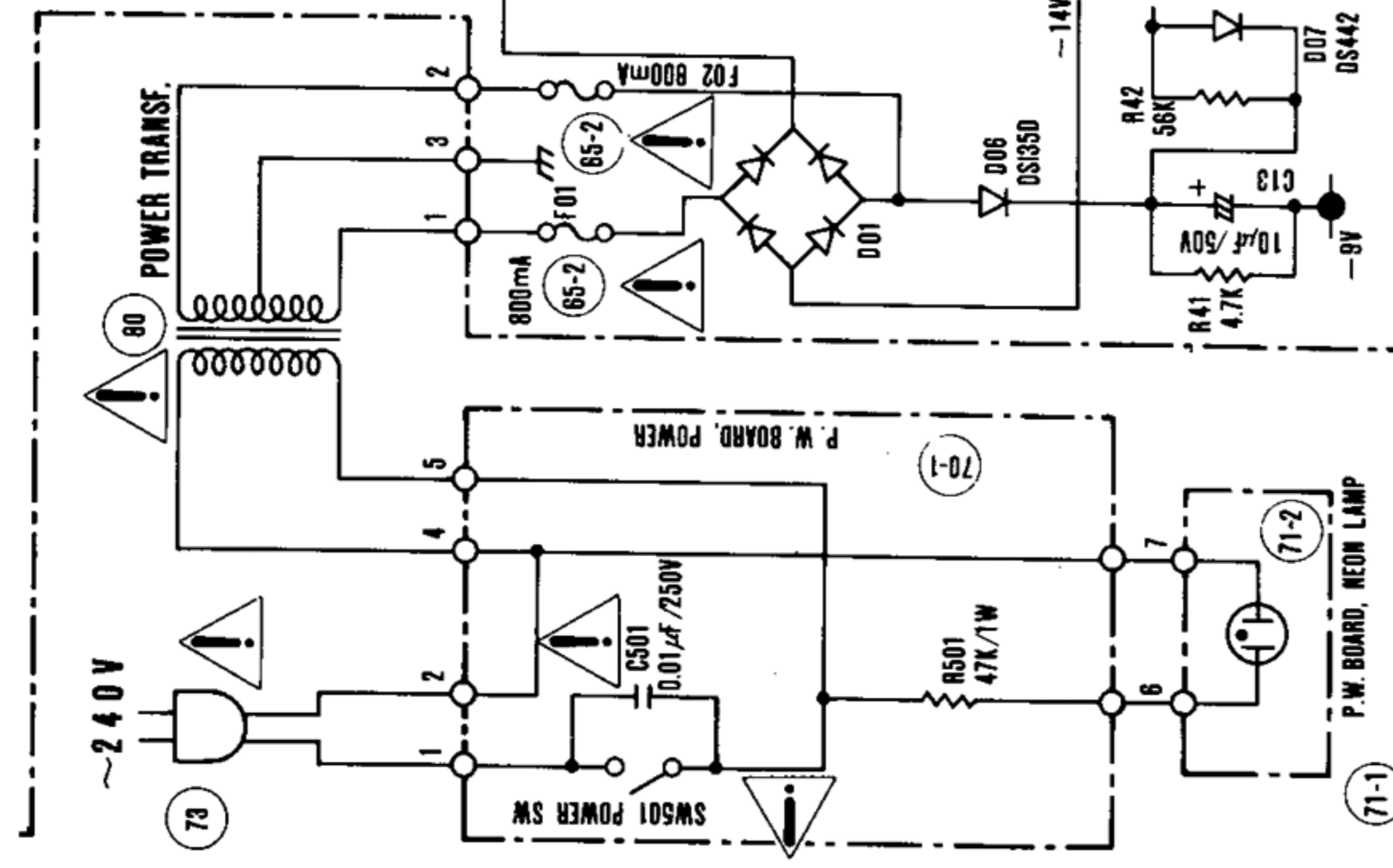
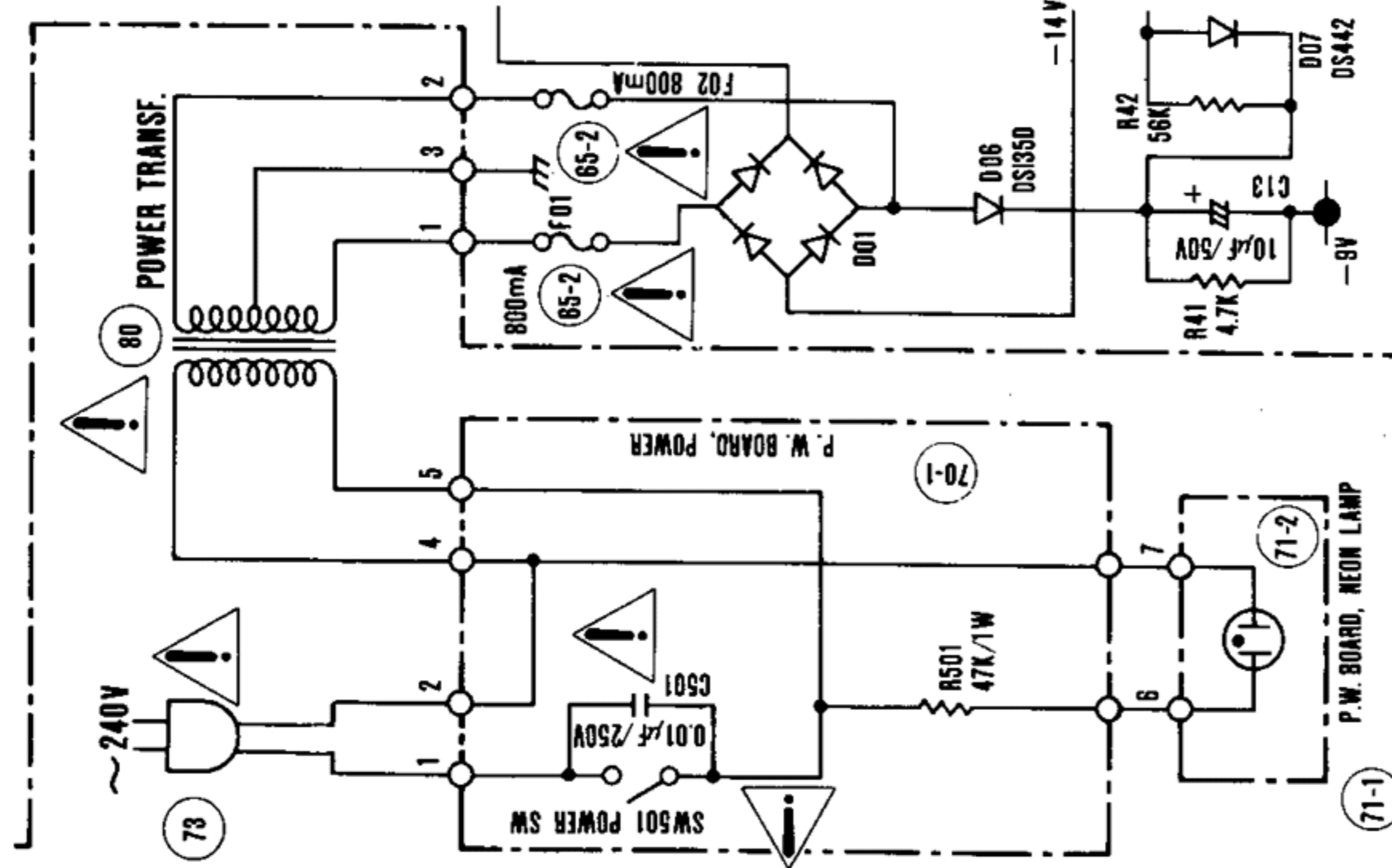
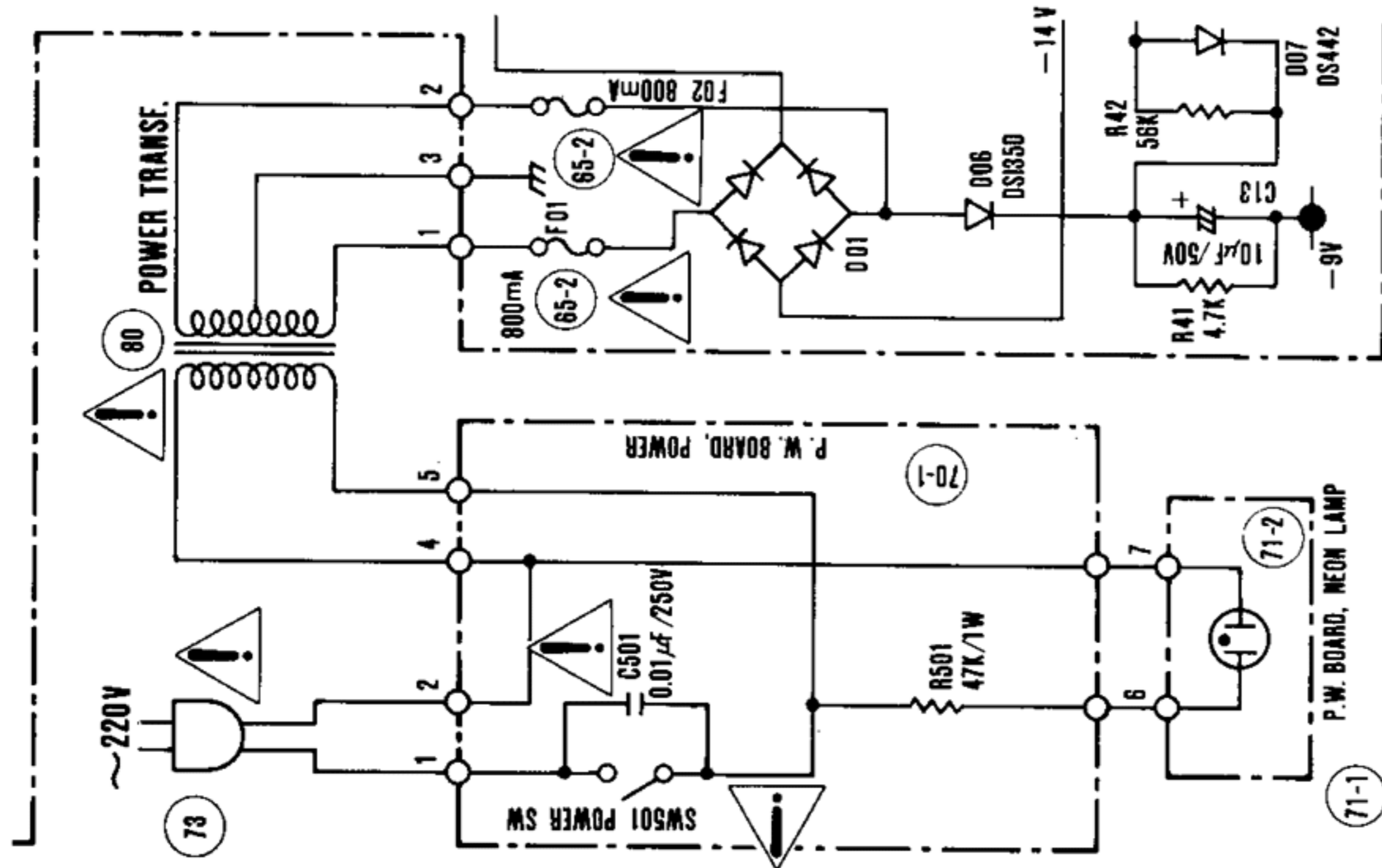

A	33rpm -9V
B	45rpm +9V
C	PU TO RIGHT +6V
D	PU TO LEFT -6V
E	PU AT REST -9V
F	PU AT REST +9V
G	PU AT REST 0V
H	PU AT REST 8.4V
	PU AT REST 0V
	PU AT REST 8.4V

I	30cm RECORD +9V
J	17cm RECORD +8V
K	SW ON 0V
L	SW OFF 9V
M	PU MOVE +9V
N	PU TO RIGHT +9V
O	PU SLOW MOVE +9V
P	PU TO LEFT +9V
	PU AT PLAY +9V
	PU AT PLAY +9V
	PU AT PLAY 8.4V
	PU AT PLAY 8.4V
	+5V 0V 400KHz

To service personnel
 Make sure that only replacement parts recommended by the manufacturer should be used when the parts marked "!" in schematic diagram are exchanged.
 Never fail to make leakage-current or resistance measurements before returning the appliance to the customer so as to make sure that exposed parts are acceptably insulated from the supply circuit.

N/T/A VERSION

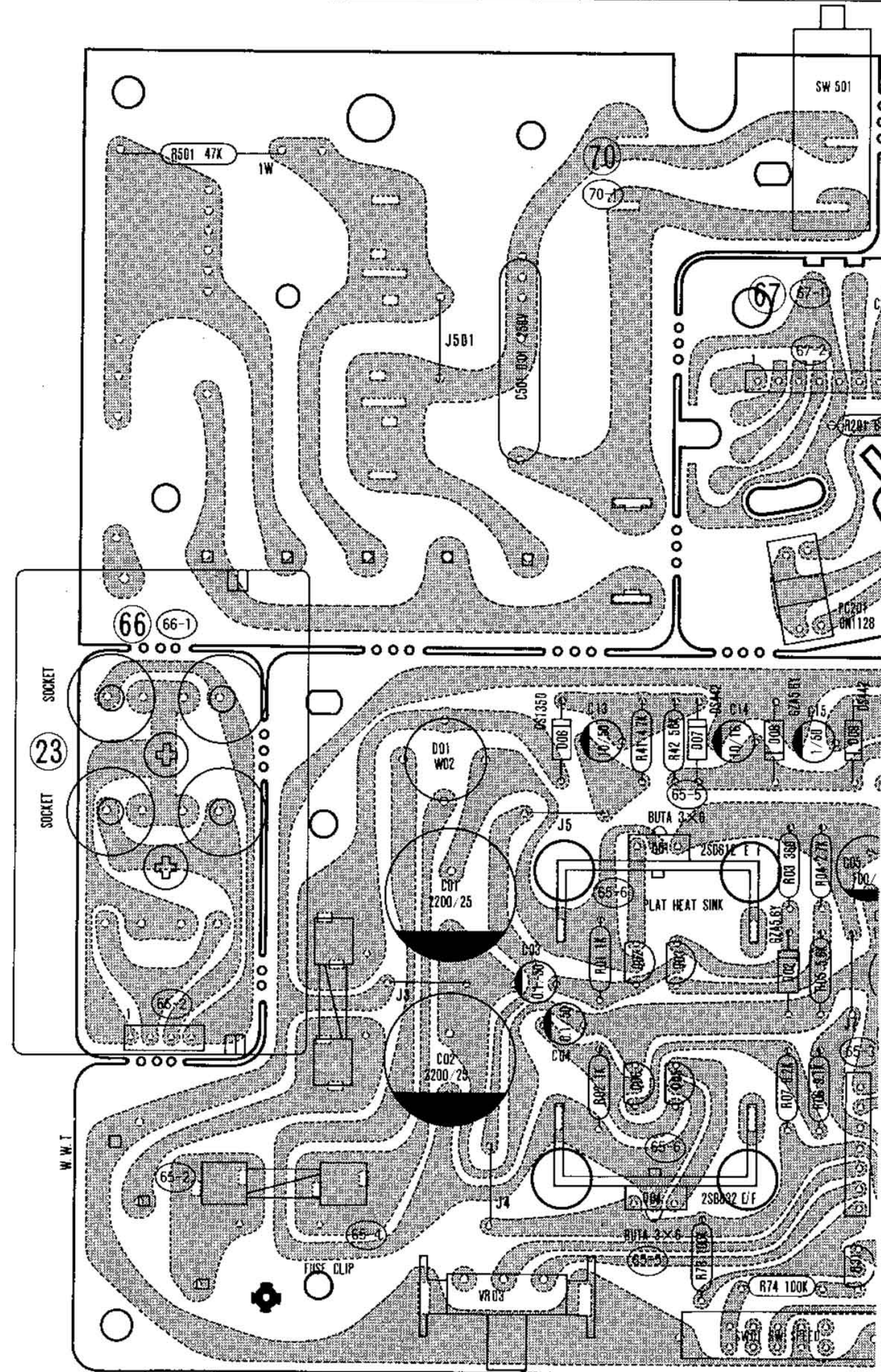

U/C VERSION

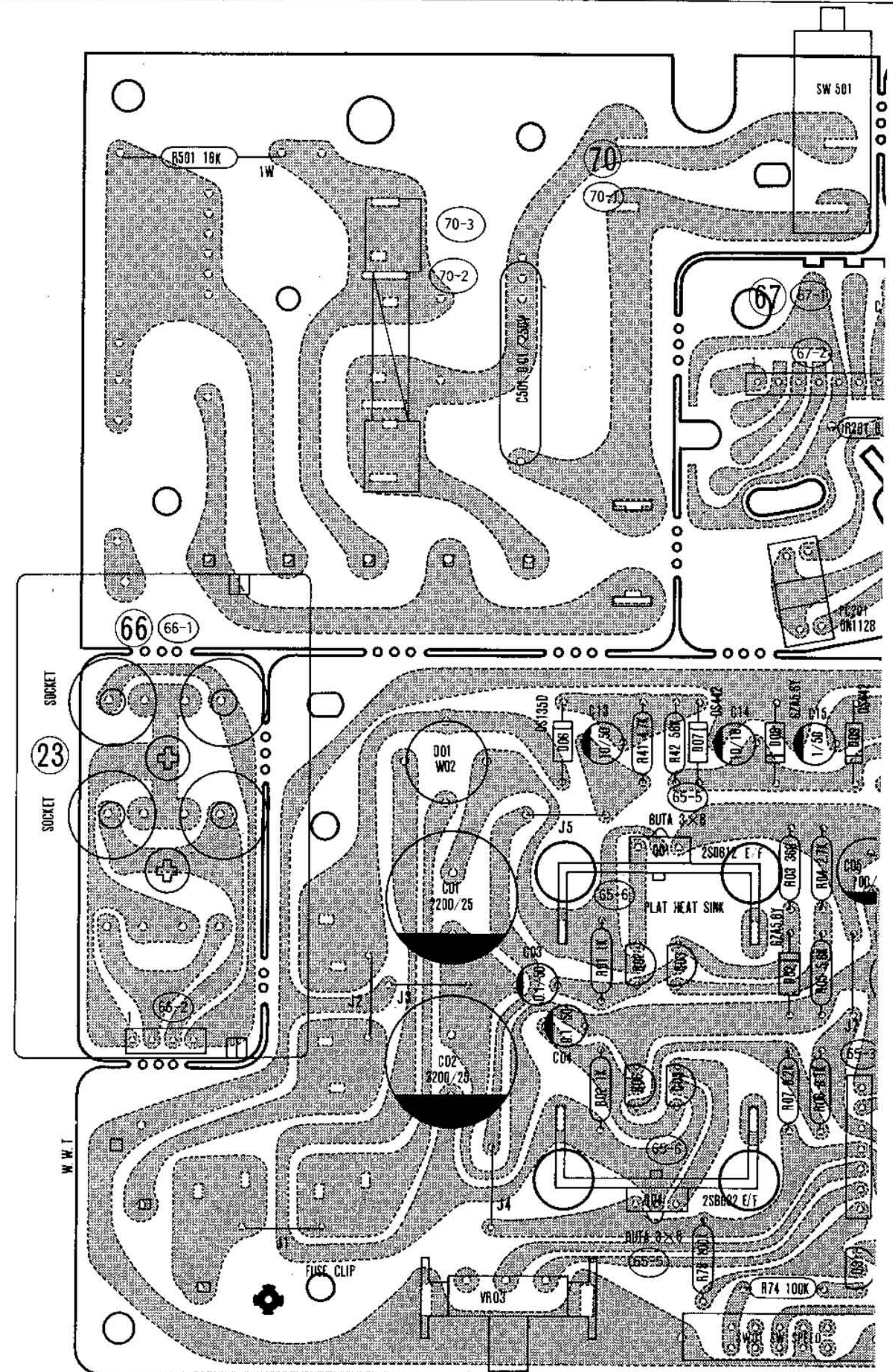

11. (C01-99) EXPLODED VIEW

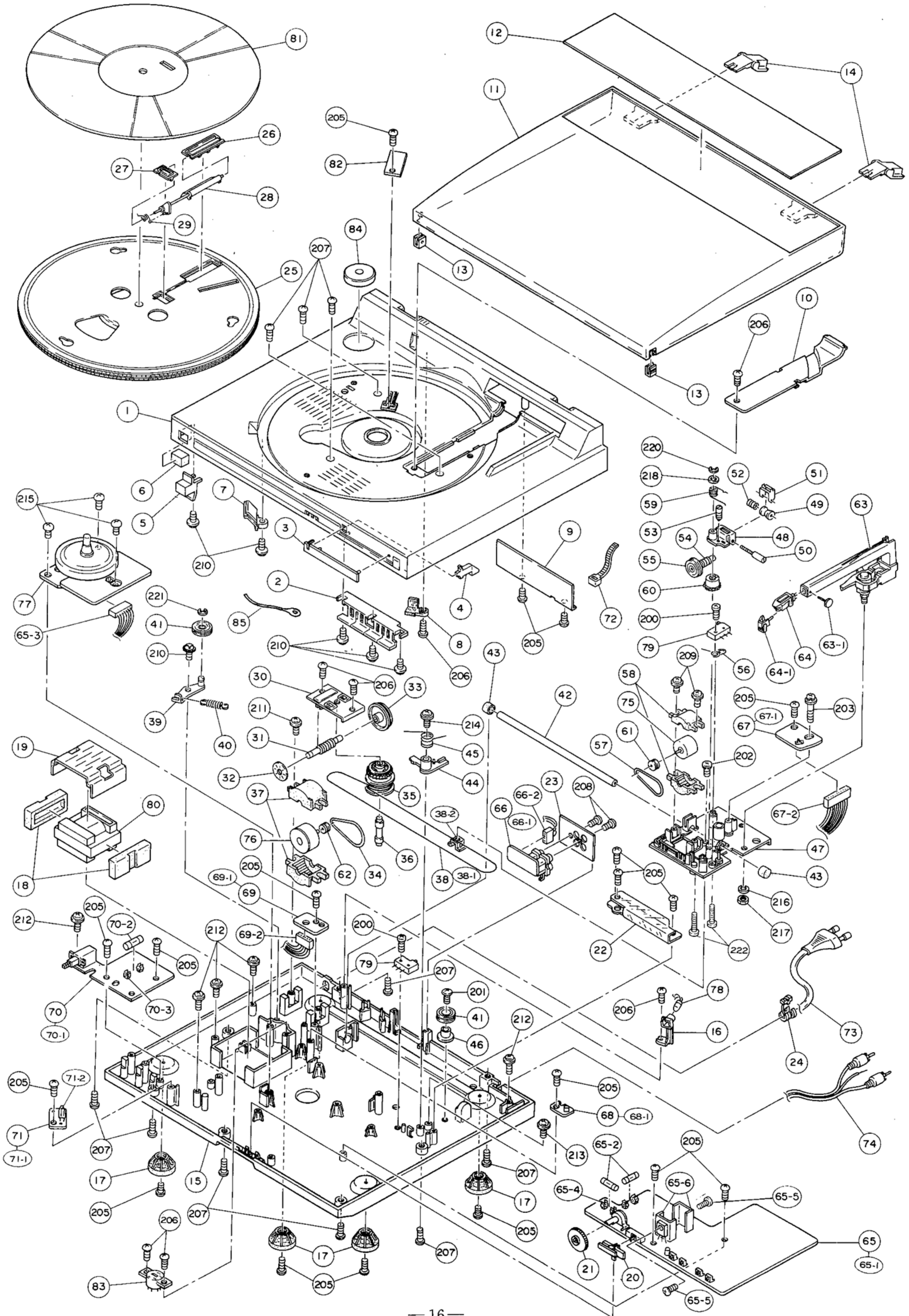

12. (H01-99) PACKING MATERIALS

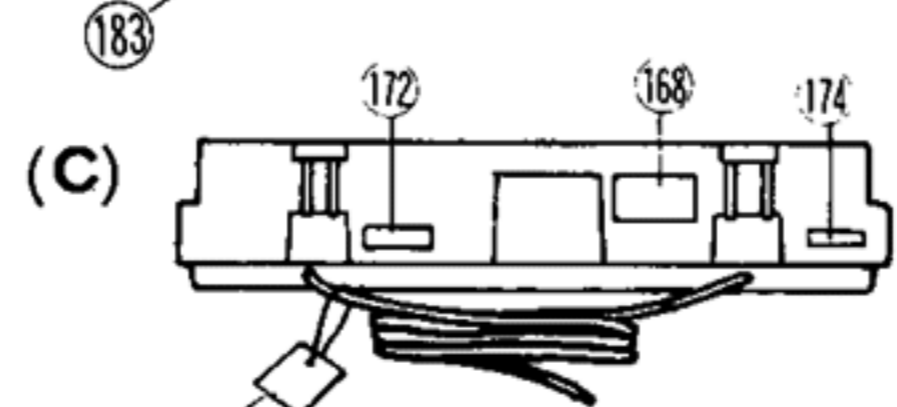
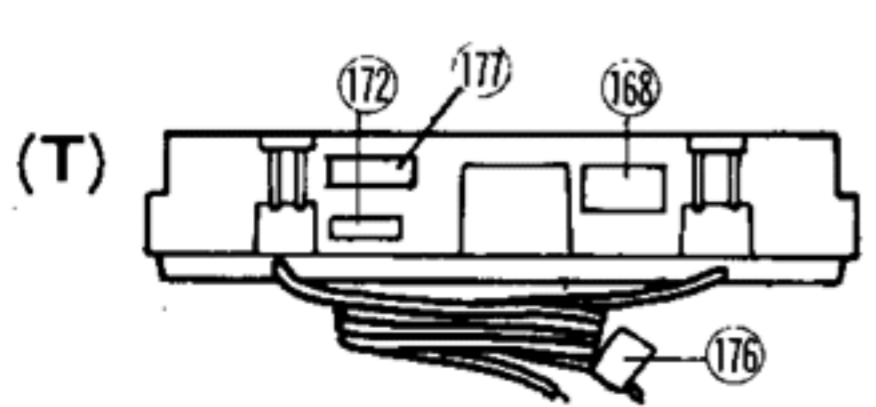
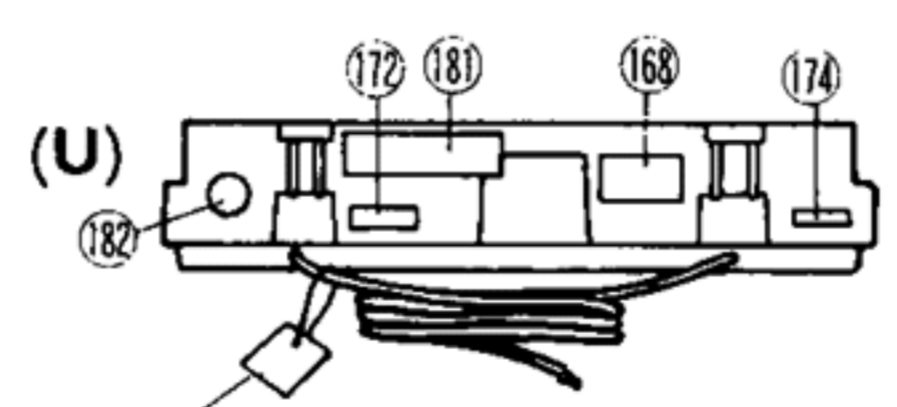
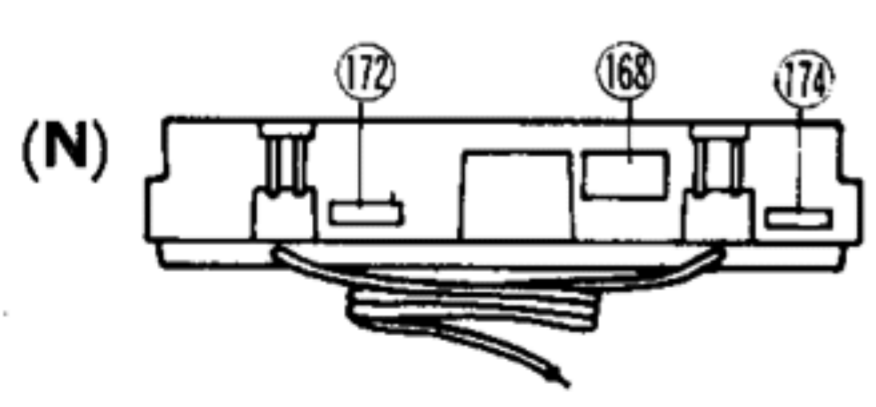
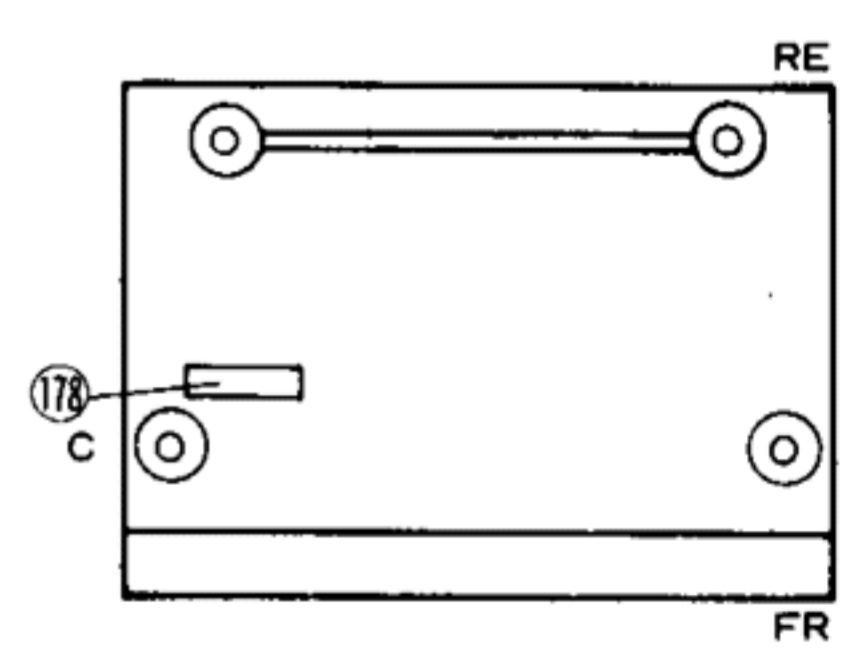
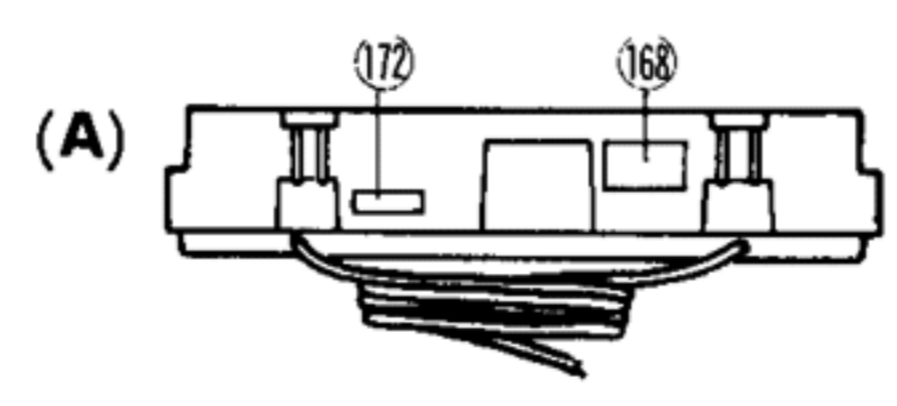
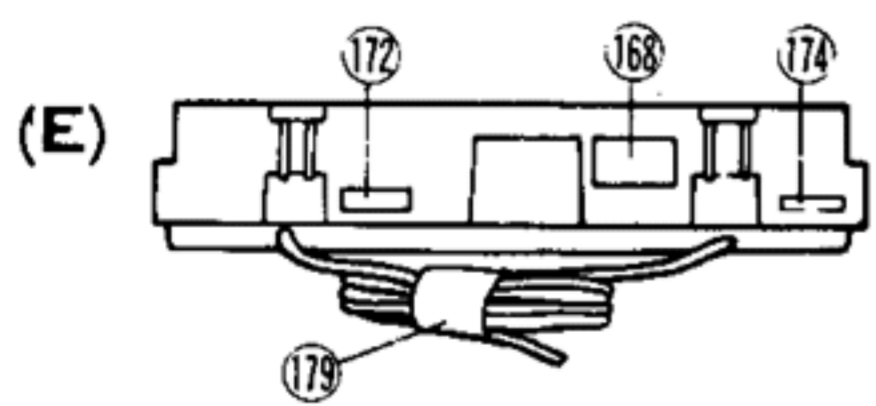
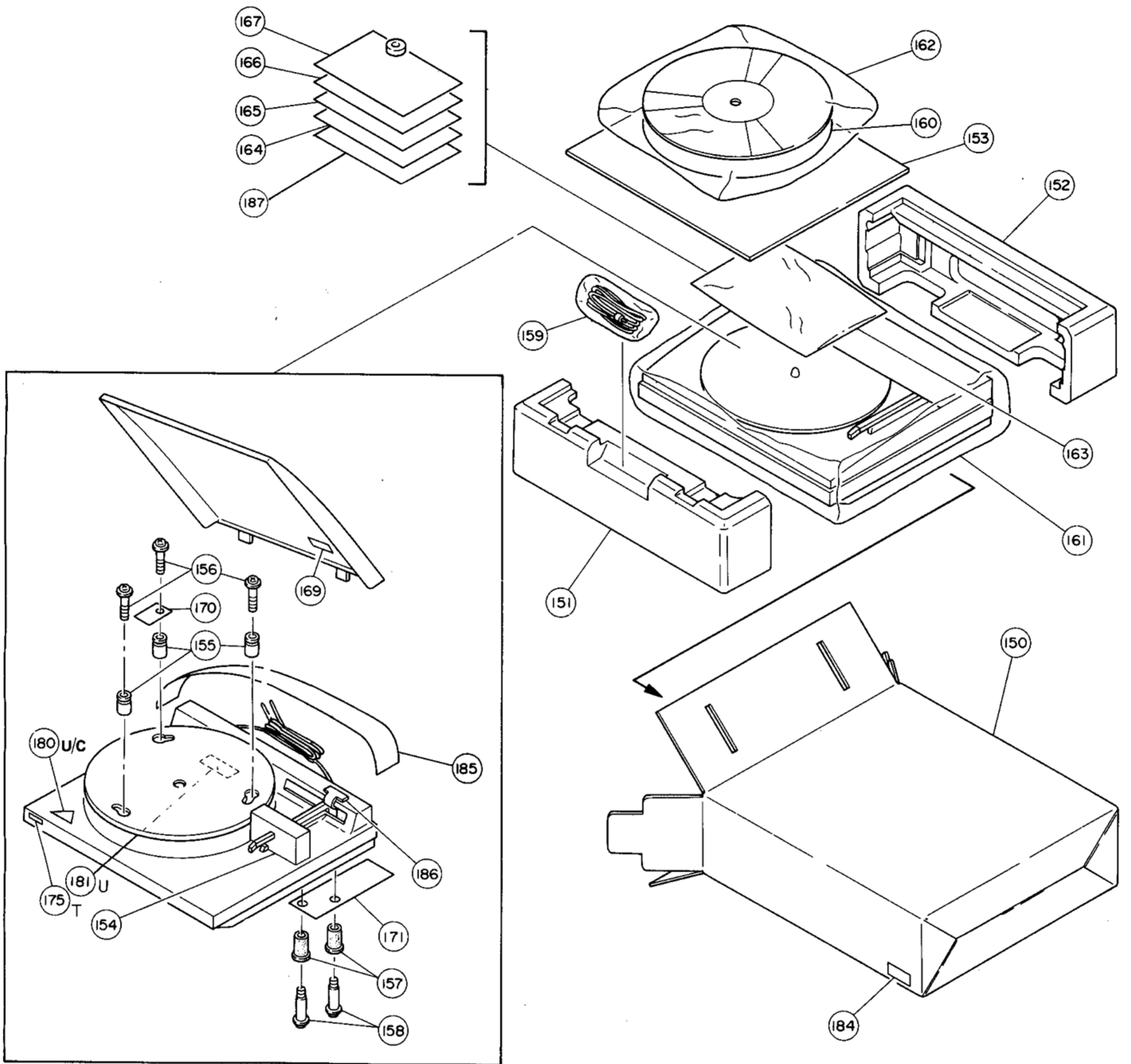

13. PARTS LIST

(E): for Europe
 (N): for Europe
 (T): for England
 (A): for Australia
 (U): for U.S.A.
 (C): for Canada

REF. DESIG.	Q'TY						PART NO.	DESCRIPTION	REF. DESIG.	Q'TY						PART NO.	DESCRIPTION
	E	N	T	A	U	C				E	N	T	A	U	C		
1	1	1	1	1	1	1	427Z064010	Case Top	57	1	1	1	1	1	1	427Z264020	Belt
2	1	1	1	1	1	1	427Z270010	Button, Rep/Cue/Play/Cut	58	2	2	2	2	2	2	427Z053070	Cover (Small), PU up/down Motor
3	1	1	1	1	1	1	427Z063010	Escutcheon	59	1	1	1	1	1	1	427Z115060	Spring
4	1	1	1	1	1	1	427Z265010	Indicator	60	1	1	1	1	1	1	427Z054010	Cam
5	1	1	1	1	1	1	427Z270020	Button, Power	61	1	1	1	1	1	1	427Z262040	Pulley, PU Motor
6	1	1	1	1	1	1	427Z809010	Cushion	62	1	1	1	1	1	1	427Z262050	Pulley, Servo Motor
7	1	1	1	1	1	1	427Z053020	Cover, Strobe	63	1	1	1	1			PA220001AR	Tonearm
8	1	1	1	1	1	1	427Z053030	Cover, Rec. Size	63					1	1	PA220002AR	Tonearm
9	1	1	1	1	1	1	427Z053040	Cover	63-1	1	1	1	1	1	1	427Z010020	Screw, Cartridge
10	1	1	1	1	1	1	427Z053050	Cover, Case	64	1	1	1	1	1	1	PC221005AR	Cartridge
11	1	1	1	1	1	1	427Z053010	Cover, Dust cover	64-1	1	1	1	1	1	1	PS221005AR	Stylus
12	1	1	1	1	1	1	427Z063020	Escutcheon, Dust cover									
13	2	2	2	2	2	2	427Z252010	Pad, Dust cover		1	1	1	1	1	1	YH427Z1700	P.W.B Kit
14	2	2	2	2	2	2	427Z153010	Hinge			1	1	1			ZZ427Z1700	P.W.B Kit Ass'y
15	1	1	1	1	1	1	427Z064020	Case, Bottom		1						ZZ427Z2700	P.W.B Kit Ass'y
15						1	427Z064030	Case, Bottom						1	1	ZZ427Z3700	P.W.B Kit Ass'y
16	1	1	1	1	1	1	427Z271010	Holder									
17	4	4	4	4	4	4	427Z057010	Leg	65-1	1	1	1	1	1	1	YH427Z1710	P.W.Board, Control
18	2	2	2	2	2	2	427Z809010	Cushion	65		1	1	1			ZZ427Z1710	P.W.B Ass'y, Control
19	1	1	1	1	1	1	427Z271020	Holder	65	1						ZZ427Z2710	P.W.B Ass'y, Control
									65					1	1	ZZ427Z3710	P.W.B Ass'y, Control
20	1	1	1	1	1	1	427Z154010	Knob, Speed Change	66-1	1	1	1	1	1	1	YH427Z1720	P.W.Board, Remote
21	1	1	1	1	1	1	427Z154020	Knob, Pitch Control	66		1	1	1			ZZ427Z1720	P.W.B Ass'y, Remote
22	1	1	1	1	1	1	427Z051010	Guide, Tonearm Wire	66	1						ZZ427Z2720	P.W.B Ass'y, Remote
23	1	1	1	1	1	1	427Z265020	Indicator	66					1	1	ZZ427Z3720	P.W.B Ass'y, Remote
24	1	1	1	1	1	1	427Z259010	Bush									
24						1	427Z259020	Bush	67-1	1	1	1	1	1	1	YH427Z1730	P.W.Board, Phono
25	1	1	1	1	1	1	427Z165010	Turntable	67		1	1	1			ZZ427Z1730	P.W.B Ass'y, Phono
26	1	1	1	1	1	1	427Z271030	Holder, Rec. Size	67	1						ZZ427Z2730	P.W.B Ass'y, Phono
27	1	1	1	1	1	1	427Z271040	Holder, Rec. Size	67					1	1	ZZ427Z3730	P.W.B Ass'y, Phono
28	1	1	1	1	1	1	427Z354500	Lever K, Rec. Size									
29	1	1	1	1	1	1	427Z115010	Spring, Rec. Size	68-1	1	1	1	1	1	1	YH427Z1740	P.W.Board, Record
30	1	1	1	1	1	1	427Z106500	Sustainer K, Worm	68		1	1	1			ZZ427Z1740	P.W.B Ass'y, Record
31	1	1	1	1	1	1	427Z058010	Gear (1), Worm	68	1						ZZ427Z2740	P.W.B Ass'y, Record
32	1	1	1	1	1	1	427Z110010	Shifter	68					1	1	ZZ427Z3740	P.W.B Ass'y, Record
33	1	1	1	1	1	1	427Z262010	Pulley, Servo Cont.									
34	1	1	1	1	1	1	427Z264010	Belt, Servo Cont.	69-1	1	1	1	1	1	1	YH427Z1750	P.W.Board, Position
35	1	1	1	1	1	1	427Z266010	Wheel, Steel Wire	69		1	1	1			ZZ427Z1750	P.W.B Ass'y, Position
36	1	1	1	1	1	1	427Z112010	Shaft	69	1						ZZ427Z2750	P.W.B Ass'y, Position
37	2	2	2	2	2	2	427Z053060	Cover, (Large), Servo Cont. Motor	69					1	1	ZZ427Z3750	P.W.B Ass'y, Position
38	1	1	1	1	1	1	427Z006500	String K, Steel Wire	70-1	1	1	1	1	1	1	YH427Z1760	P.W.Board, Power
38-1	1	1	1	1	1	1	427Z006010	String, Steel Wire	70		1	1	1			ZZ427Z1760	P.W.B Ass'y, Power
38-2	1	1	1	1	1	1	427Z051040	Guide, Steel Wire	70	1						ZZ427Z2760	P.W.B Ass'y, Power
39	1	1	1	1	1	1	427Z354510	Lever K, Steel Wire	70					1	1	ZZ427Z3760	P.W.B Ass'y, Power
40	1	1	1	1	1	1	427Z115020	Spring, Wire Pulley	71-1	1	1	1	1	1	1	YH427Z1770	P.W.Board, Neon Lamp
41	2	2	2	2	2	2	427Z262020	Pulley, Steel Wire	71		1	1	1			ZZ427Z1770	P.W.B Ass'y, Neon Lamp
42	1	1	1	1	1	1	427Z051020	Guide, Tonearm Block	71	1						ZZ427Z2770	P.W.B Ass'y, Neon Lamp
43	2	2	2	2	2	2	427Z809020	Cushion, Tonearm Guide	71					1	1	ZZ427Z3770	P.W.B Ass'y, Neon Lamp
44	1	1	1	1	1	1	427Z002010	Arm, Tonearm Slide SW.									
45	1	1	1	1	1	1	427Z115030	Spring									
46	1	1	1	1	1	1	427Z118010	Spacer, Wire Pulley									
47	1	1	1	1	1	1	427Z160500	Bracket K, Tonearm									CONTROL CIRCUIT BOARD
48	1	1	1	1	1	1	427Z160010	Bracket, Tonearm up/down	65-1	1	1	1	1	1	1	YH427Z1710	P.W.Board, Control
49	1	1	1	1	1	1	427Z051030	Guide, Tonearm	65		1	1	1			ZZ427Z1710	P.W.B Ass'y, Control
50	1	1	1	1	1	1	427Z164010	Adjuster	65	1						ZZ427Z2710	P.W.B Ass'y, Control
51	1	1	1	1	1	1	427Z269010	Protector	65					1	1	ZZ427Z3710	P.W.B Ass'y, Control
52	1	1	1	1	1	1	427Z115040	Spring									
53	1	1	1	1	1	1	427Z010010	Screw	△ 65-2		2	2	2			FS10080800	Fuse, 800mAT
54	1	1	1	1	1	1	427Z058020	Gear (2), Worm	△ 65-2	2						FS10063800	Fuse, 630mAT
55	1	1	1	1	1	1	427Z262030	Pulley	65-3	1	1	1	1	1	1	YB001006AR	Connective Cord, 7P
56	1	1	1	1	1	1	427Z115050	Spring, Cam	65-4	4	4	4	4			YJ080003AR	Jack, Fuse Holder
									65-5	2	2	2	2	2	2	427Z010180	Screw, φ3 x 6
									65-6	2	2	2	2	2	2	427Z267010	Heat-Sink

PARTS LIST

(E): for Europe
 (N): for Europe
 (T): for England
 (A): for Australia
 (U): for U.S.A.
 (C): for Canada

REF. DESIG.	Q'TY						PART NO.	DESCRIPTION	REF. DESIG.	Q'TY						PART NO.	DESCRIPTION
	E	N	T	A	U	C				E	N	T	A	U	C		
CAPACITORS																	
C01	1	1	1	1	1	1	EA2280251R	Elect. 2200μF 25V	R46	1	1	1	1	1	1	GD05102140	1KΩ
C02	1	1	1	1	1	1	EA2280251R	Elect. 2200μF 25V	R47	1	1	1	1	1	1	GD05153140	15KΩ
C03	1	1	1	1	1	1	EA10405030	Elect. 0.1μF 50V	R48	1	1	1	1	1	1	GD05103140	10KΩ
C04	1	1	1	1	1	1	EA10405030	Elect. 0.1μF 50V	R49	1	1	1	1	1	1	GD05103140	10KΩ
C05	1	1	1	1	1	1	EA10701630	Elect. 100μF 16V	R50	1	1	1	1	1	1	GD05471140	470Ω
C06	1	1	1	1	1	1	EA10701630	Elect. 100μF 16V	R51	1	1	1	1	1	1	GD05472140	4.7KΩ
C07	1	1	1	1	1	1	DK18103320	Ceramic 0.01μF +80, -20%	R52	1	1	1	1	1	1	GD05222140	2.2KΩ
C08	1	1	1	1	1	1	DK18103320	Ceramic 0.01μF +80, -20%	R53	1	1	1	1	1	1	GD05103140	10KΩ
C09	1	1	1	1	1	1	DK16221300	Ceramic 220pF ±10%	R54	1	1	1	1	1	1	GD05103140	10KΩ
C10	1	1	1	1	1	1	DK16221300	Ceramic 220pF ±10%	R55	1	1	1	1	1	1	GD05821140	820Ω
C13	1	1	1	1	1	1	EA10605030	Elect. 10μF 50V	R56	1	1	1	1	1	1	GD05473140	47KΩ
C14	1	1	1	1	1	1	EA10601630	Elect. 10μF 16V	R57	1	1	1	1	1	1	GD05822140	8.2KΩ
C15	1	1	1	1	1	1	EA10505030	Elect. 1μF 50V	R58	1	1	1	1	1	1	GD05473140	47KΩ
C17	1	1	1	1	1	1	DK18103320	Ceramic 0.01μF +80, -20%	R59	1	1	1	1	1	1	GD05104140	100KΩ
C18	1	1	1	1	1	1	DK18473320	Ceramic 0.047μF +80, -20%	R60	1	1	1	1	1	1	GD05183140	18KΩ
C19	1	1	1	1	1	1	DK18473320	Ceramic 0.047μF +80, -20%	R61	1	1	1	1	1	1	GD05104140	100KΩ
C20	1	1	1	1	1	1	DK18473320	Ceramic 0.047μF +80, -20%	R62	1	1	1	1	1	1	GD05104140	100KΩ
C21	1	1	1	1	1	1	DK18473320	Ceramic 0.047μF +80, -20%	R63	1	1	1	1	1	1	GD05104140	100KΩ
C22	1	1	1	1	1	1	DK18473320	Ceramic 0.047μF +80, -20%	R64	1	1	1	1	1	1	GD05104140	100KΩ
RESISTORS																	
(All Resistors are ±5% and 1/4W)																	
R01	1	1	1	1	1	1	GD05102140	1KΩ	R66	1	1	1	1	1	1	GD05104140	100KΩ
R02	1	1	1	1	1	1	GD05102140	1KΩ	R67	1	1	1	1	1	1	GD05104140	100KΩ
R03	1	1	1	1	1	1	GD05361140	360Ω	R68	1	1	1	1	1	1	GD05104140	100KΩ
R04	1	1	1	1	1	1	GD05272140	2.7KΩ	R69	1	1	1	1	1	1	GD05104140	100KΩ
R05	1	1	1	1	1	1	GD05562140	5.6KΩ	R70	1	1	1	1	1	1	GD05104140	100KΩ
R06	1	1	1	1	1	1	GD05912140	9.1KΩ	R71	1	1	1	1	1	1	GD05104140	100KΩ
R07	1	1	1	1	1	1	GD05822140	8.2KΩ	R72	1	1	1	1	1	1	GD05102140	1KΩ
R08	1	1	1	1	1	1	GD05561140	560Ω	R73	1	1	1	1	1	1	GD05102140	1KΩ
R09	1	1	1	1	1	1	GD05752140	7.5KΩ	R74	1	1	1	1	1	1	GD05104140	100KΩ
R10	1	1	1	1	1	1	GD05122140	1.2KΩ	R75	1	1	1	1	1	1	GD05183140	18KΩ
R11	1	1	1	1	1	1	GD05103140	10KΩ	R76	1	1	1	1	1	1	GD05221140	220Ω
R12	1	1	1	1	1	1	GD05103140	10KΩ	R77	1	1	1	1	1	1	GD05104140	100KΩ
R13	1	1	1	1	1	1	GD05104140	100KΩ	R78	1	1	1	1	1	1	GD05104140	100KΩ
R14	1	1	1	1	1	1	GD05203140	20KΩ	R79	1	1	1	1	1	1	GD05104140	100KΩ
R15	1	1	1	1	1	1	GD05103140	10KΩ	R80	1	1	1	1	1	1	GD05183140	18KΩ
R16	1	1	1	1	1	1	GD05103140	10KΩ	R81	1	1	1	1	1	1	GD05680140	68Ω
R17	1	1	1	1	1	1	GD05103140	10KΩ	R82	1	1	1	1	1	1	GD05680140	68Ω
R18	1	1	1	1	1	1	GD05183140	18KΩ	R83	1	1	1	1	1	1	GD05680140	68Ω
R19	1	1	1	1	1	1	GD05183140	18KΩ	R84	1	1	1	1	1	1	GD05680140	68Ω
R20	1	1	1	1	1	1	GD05183140	18KΩ	VR01	1	1	1	1	1	1	RA03030800	Trimming 30KΩ
R21	1	1	1	1	1	1	GD05183140	18KΩ	VR02	1	1	1	1	1	1	RA02020800	Trimming 2KΩ
R22	1	1	1	1	1	1	GD05104140	100KΩ	VR03	1	1	1	1	1	1	RK050202AR	Variable 5KΩ (B)
R23	1	1	1	1	1	1	GD05104140	100KΩ	SEMICONDUCTORS								
R24	1	1	1	1	1	1	GD05104140	100KΩ	IC01	1	1	1	1	1	1	HC10135030	IC, LA6324
R25	1	1	1	1	1	1	GD05104140	100KΩ	IC02	1	1	1	1	1	1	HC406603C0	IC, LC4066BH
R26	1	1	1	1	1	1	GD05104140	100KΩ	IC03	1	1	1	1	1	1	HC100021AR	IC, LM6416E-205
R27	1	1	1	1	1	1	GD05104140	100KΩ	IC04	1	1	1	1	1	1	HC10102030	IC, LM6416E-156
R28	1	1	1	1	1	1	GD05104140	100KΩ	Q01	1	1	1	1	1	1	HT406122AR	Transistor, 2SD612(E, F)
R29	1	1	1	1	1	1	GD05105140	1MΩ	Q02	1	1	1	1	1	1	HT305362B0	Transistor, 2SC536NP (E, F)
R30	1	1	1	1	1	1	GD05103140	10KΩ	Q03	1	1	1	1	1	1	HT305362B0	Transistor, 2SC536NP (E, F)
R31	1	1	1	1	1	1	GD05103140	10KΩ	Q04	1	1	1	1	1	1	HT206322AR	Transistor, 2SB632 (E, F)
R32	1	1	1	1	1	1	GD05472140	4.7KΩ	Q05	1	1	1	1	1	1	HT106082AR	Transistor, 2SA608NP (E, F)
R33	1	1	1	1	1	1	GD05104140	100KΩ	Q06	1	1	1	1	1	1	HT106082AR	Transistor, 2SA608NP (E, F)
R37	1	1	1	1	1	1	GD05104140	100KΩ	Q07	1	1	1	1	1	1	HT408632B0	Transistor, 2SD863 (E, F)
R38	1	1	1	1	1	1	GD05103140	10KΩ	Q08	1	1	1	1	1	1	HT207642B0	Transistor, 2SB764 (E, F)
R41	1	1	1	1	1	1	GD05472140	4.7KΩ	Q09	1	1	1	1	1	1	HT106082AR	Transistor, 2SA608NP (E, F)
R42	1	1	1	1	1	1	GD05563140	56KΩ	Q10	1	1	1	1	1	1	HT106082AR	Transistor, 2SA608NP (E, F)
R43	1	1	1	1	1	1	GD05103140	10KΩ									
R44	1	1	1	1	1	1	GD05104140	100KΩ									
R45	1	1	1	1	1	1	GD05183140	18KΩ									

(E): for Europe
 (N): for Europe
 (T): for England
 (A): for Australia
 (U): for U.S.A.
 (C): for Canada

PARTS LIST

REF. DESIG.	Q'TY						PART NO.	DESCRIPTION	REF. DESIG.	Q'TY						PART NO.	DESCRIPTION	
	E	N	T	A	U	C				E	N	T	A	U	C			
Q11	1	1	1	1	1	1	HT106082AR	Transistor, 2SA608NP (E, F)	C201	1	1	1	1	1	1	DK18103320	Ceramic 0.01μF+80, -20%	
Q12	1	1	1	1	1	1	HT106082AR	Transistor, 2SA608NP (E, F)	R201	1	1	1	1	1	1	GD05681140	680 Ω 1/4W ±5%	
Q13	1	1	1	1	1	1	HT106082AR	Transistor, 2SA608NP (E, F)	PC201	1	1	1	1	1	1	HW100001AR	Photo Unit, ON1128	
Q14	1	1	1	1	1	1	HT305362B0	Transistor, 2SC536NP (E, F)	67-2	1	1	1	1	1	1	YB004003AR	Connective Cord, 10P	
Q15	1	1	1	1	1	1	HT408632B0	Transistor, 2SD863 (E, F)									RECORD CIRCUIT BOARD	
Q16	1	1	1	1	1	1	HT207642B0	Transistor, 2SB764 (E, F)	68-1	1	1	1	1	1	1	YH427Z1740	P.W.Board, Record	
Q17	1	1	1	1	1	1	HT106082AR	Transistor, 2SA608NP (E, F)	68		1	1				ZZ427Z1740	P.W.B Ass'y, Record	
Q19	1	1	1	1	1	1	HT106082AR	Transistor, 2SA608NP (E, F)	68	1						ZZ427Z2740	P.W.B Ass'y, Record	
Q20	1	1	1	1	1	1	HT408632B0	Transistor, 2SD863 (E, F)	68				1	1		ZZ427Z3740	P.W.B Ass'y, Record	
Q21	1	1	1	1	1	1	HT305362B0	Transistor, 2SC536NP (E, F)	Q301	1	1	1	1	1	1	HF0000001R	Photo Transistor, PN150	
Q22	1	1	1	1	1	1	HT106082AR	Transistor, 2SA608NP (E, F)									POSITION CIRCUIT BOARD	
Q23	1	1	1	1	1	1	HT305362B0	Transistor, 2SC536NP (E, F)	69-1	1	1	1	1	1	1	YH427Z1750	P.W.Board, Position	
Q24	1	1	1	1	1	1	HT305362B0	Transistor, 2SC536NP (E, F)	69		1	1				ZZ427Z1750	P.W.B Ass'y, Position	
Q25	1	1	1	1	1	1	HT305362B0	Transistor, 2SC536NP (E, F)	69	1						ZZ427Z2750	P.W.B Ass'y, Position	
Q26	1	1	1	1	1	1	HT305362B0	Transistor, 2SC536NP (E, F)	69				1	1		ZZ427Z3750	P.W.B Ass'y, Position	
Q27	1	1	1	1	1	1	HT305362B0	Transistor, 2SC536NP (E, F)	C401	1	1	1	1	1	1	DK18103320	Ceramic 0.01μF+80, -20%	
Q28	1	1	1	1	1	1	HT305362B0	Transistor, 2SC536NP (E, F)	R401	1	1	1	1	1	1	GD05162140	1.6KΩ 1/4W ±5%	
Q29	1	1	1	1	1	1	HT305362B0	Transistor, 2SC536NP (E, F)	PC401	1	1	1	1	1	1	HW100001AR	Photo Unit, ON1128	
Q30	1	1	1	1	1	1	HT305362B0	Transistor, 2SC536NP (E, F)	69-2	1	1	1	1	1	1	YB003007AR	Connective Cord, 6P	
Q31	1	1	1	1	1	1	HT106082AR	Transistor, 2SA608NP (E, F)									POWER CIRCUIT BOARD	
Q32	1	1	1	1	1	1	HT207642B0	Transistor, 2SB764 (E, F)	70-1	1	1	1	1	1	1	YH427Z1760	P.W. Board, Power	
Q33	1	1	1	1	1	1	HT106082AR	Transistor, 2SA608NP (E, F)	70		1	1				ZZ427Z1760	P.W.B Ass'y, Power	
Q34	1	1	1	1	1	1	HT106082AR	Transistor, 2SA608NP (E, F)	70	1						ZZ427Z2760	P.W.B Ass'y, Power	
D01	1	1	1	1	1	1	HE200003AR	Diode, W02	70				1	1		ZZ427Z3760	P.W.B Ass'y, Power	
D02	1	1	1	1	1	1	HD300006AR	Zener, GZA5.6Y	Δ C501	1	1	1				DF7610301R	Film 0.01μF 250V	
D04	1	1	1	1	1	1	HD20015030	Diode, DS135D	Δ C501					1	1	DF7610302R	Film 0.01μF 125V	
D06	1	1	1	1	1	1	HD20015030	Diode, DS135D	R501		1	1				GA05473010	47KΩ 1W ±5%	
D07	1	1	1	1	1	1	HD2001703R	Diode, DS-442	R501	1						GA05183010	18KΩ 1W ±5%	
D08	1	1	1	1	1	1	HD300006AR	Zener, GZA5.6Y	Δ SW501	1	1	1	1	1	1	SP01010660	Push SW. Power	
D09	1	1	1	1	1	1	HD2001703R	Diode, DS-442	Δ 70-2				1	1		FS100251AR	Fuse, 250mA	
D11	1	1	1	1	1	1	HD300006AR	Zener, GZA5.6Y	70-3					2	2	YJ080004AR	JACK, Fuse Holder	
D12	1	1	1	1	1	1	HD2001703R	Diode, DS-442									NEON LAMP CIRCUIT BOARD	
D13	1	1	1	1	1	1	HD2001703R	Diode, DS-442	71-1	1	1	1	1	1	1	YH427Z1770	P.W.Board, Neon Lamp	
D14	1	1	1	1	1	1	HD2001703R	Diode, DS-442	71		1	1				ZZ427Z1770	P.W.B Ass'y, Neon Lamp	
LED	1	1	1	1	1	1	HI100017AR	L.E.D LN21RCPHL	71	1						ZZ427Z2770	P.W.B Ass'y, Neon Lamp	
								MISCELLANEOUS										
REL	1	1	1	1	1	1	LY212001AR	Relay, 12V	71				1	1		ZZ427Z3770	P.W.B Ass'y, Neon Lamp	
SW01	1	1	1	1	1	1	SS020302AR	Slide SW. Speed	71-2	1	1	1	1	1	1	IN210101AR	Lamp, Neon	
SW02	4	4	4	4	4	4	SP01010700	Push SW. Repeat / Cue Start/Stop	72	5	5	5	5	5	5	427Z005010	Clamper	
XTAL	1	1	1	1	1	1	FQ04003010	Ceramic Vi, CSB400P	Δ 73	1	1					YC022001AR	AC Power Cord	
								REMOTE CIRCUIT BOARD										
66-1	1	1	1	1	1	1	YH427Z1720	P.W.Board, Remote	Δ 73			1				YC024002AR	AC Power Cord	
66		1	1	1			ZZ427Z1720	P.W.B Ass'y, Remote	Δ 73				1			YC024003AR	AC Power Cord	
66	1						ZZ427Z2720	P.W.B Ass'y, Remote	Δ 73					1		YC022002AR	AC Power Cord	
66					1	1	ZZ427Z3720	P.W.B Ass'y, Remote	74	1	1	1				YB012002AR	Connective Cord	
66-2	1	1	1	1	1	1	YB005003AR	Connective Cord, 4P	74				1	1		YB012003AR	Connective Cord	
								PHONO CIRCUIT BOARD										
67-1	1	1	1	1	1	1	YH427Z1730	P.W.Board, Phono	75	1	1	1	1	1	1	MM005002AR	DC Motor, Arm Lift	
67		1	1	1			ZZ427Z1730	P.W.B Ass'y, Phono	76	1	1	1	1	1	1	MM005003AR	DC Motor, Tracking	
67	1						ZZ427Z2730	P.W.B Ass'y, Phono										
67					1	1	ZZ427Z3730	P.W.B Ass'y, Phono										

PARTS LIST

(E): for Europe
 (N): for Europe
 (T): for England
 (A): for Australia
 (U): for U.S.A.
 (C): for Canada

REF. DESIG.	Q'TY						PART NO.	DESCRIPTION	REF. DESIG.	Q'TY						PART NO.	DESCRIPTION
	E	N	T	A	U	C				E	N	T	A	U	C		
77	1	1	1	1	1	1	PM233008AR	Phono Motor	171	1	1	1	1	1	1	427Z861030	Label
IC01	1	1	1	1	1	1	HC406620B0	IC, M4066BP	172	1	1	1	1	1	1	2112265010	Indicator, Factory No.
Q01	1	1	1	1	1	1	HT106951ER	2SA695 (E)	174	1	1				1	427Z861050	Label
Q02	1	1	1	1	1	1	HT106951ER	2SA695 (E)	174						1	427Z861060	Label
Q03	1	1	1	1	1	1	HT106951ER	2SA695 (E)	175		1					427Z861070	Label
Q04	1	1	1	1	1	1	HT323201F0	2SC2320 (F)	176		1					427Z861080	Label
Q05	1	1	1	1	1	1	HT323201F0	2SC2320 (F)	177		1					427Z861090	Label, Caution
Q06	1	1	1	1	1	1	HT323201F0	2SC2320 (F)	178					1		427Z861110	Label
Q07	1	1	1	1	1	1	HT323201F0	2SC2320 (F)	179	1						427Z861120	Label
Q08	1	1	1	1	1	1	HT107981G0	2SA798 (G)	180					1	1	427Z861130	Label
D01	1	1	1	1	1	1	HD200001AR	Diode, US1040	181						2	427Z861140	Label
D02	1	1	1	1	1	1	HD200001AR	Diode, US1040	182						1	427Z861150	Label
D03	1	1	1	1	1	1	HD200001AR	Diode, US1040	183					1	1	427Z956010	Hang Tag
ZD01	1	1	1	1	1	1	HD30021060	Zener, RD5.1EB2	184	1		1				9526019060	Serial No. Label
VR33	1	1	1	1	1	1	RA01030800	Trimming, 10KΩ	184		1		1			9526019030	Serial No. Label
VR45	1	1	1	1	1	1	RA01030800	Trimming, 10KΩ	184					1		9526019010	Serial No. Label
LR01	1	1	1	1	1	1	NB5562230R	Resistor, 5.6KΩ 1/4W	184					1		9526019020	Serial No. Label
LR02	1	1	1	1	1	1	NB5362230R	Resistor, 3.6KΩ 1/4W	185	1	1	1	1	1	1	427Z252030	Pad
78	1	1	1	1	1	1	IN128001AR	Lamp	186	1	1	1	1	1	1	427Z252040	Pad
79	2	2	2	2	2	2	SM010205AR	Mini Switch	187	1	1	1	1	1	1	427Z851020	Instructions, Spec Fly Sheet
△80		1					TS100014AR	Power Transf.	200	2	2	2	2	2	2	427Z010030	Screw φ2 x 10
△80			1	1			TS100015AR	Power Transf.	201	1	1	1	1	1	1	427Z010040	Screw φ3 x 10
△80					1		TS100016AR	Power Transf.	202	1	1	1	1	1	1	51440306A9	L. Washer Screw P3 x 6
△80	1						TS100017AR	Power Transf.	203	1	1	1	1	1	1	427Z010050	Screw M3 x 25
△80						1	TS100018AR	Power Transf.	205	18	18	18	18	18	18	427Z010070	Screw φ3 x 8
81	1	1	1	1			427Z107010	Sheet, Turntable	206	7	5	5	5	5	5	427Z010080	Screw φ3 x 10
81					1	1	427Z107020	Sheet, Turntable	207	10	10	10	10	10	10	427Z010090	Screw φ3 x 12
82	1	1	1	1	1	1	427Z053080	Cover, Rec. Size	208	2	2	2	2	2	2	427Z010100	Screw φ3 x 8
△83	1						BY050501AR	Voltage Selector	209	2	2	2	2	2	2	427Z010110	Screw φ3 x 8
84	1	1	1	1	1	1	427Z362010	Rec. Adaptor	210	6	6	6	6	6	6	427Z010120	Screw φ3 x 8
85	1	1	1	1	1	1	427Z129500	Terminal K	211	1	1	1	1	1	1	427Z010130	Screw φ3 x 10
150	1	1	1	1			427Z801010	Packing Case	212	5	5	5	5	5	5	427Z010140	Screw φ3 x 10
150					1	1	427Z801020	Packing Case	213	1	1	1	1	1	1	427Z010150	Screw φ3 x 12
151	1	1	1	1	1	1	427Z809030	Cushion, Front	214	1	1	1	1	1	1	427Z010160	Screw φ3 x 16
152	1	1	1	1	1	1	427Z809040	Cushion, Rear	215	3	3	3	3	3	3	427Z010170	Screw φ4 x 10
153	1	1	1	1	1	1	427Z807010	Reinforcement	216	1	1	1	1	1	1	54040402A0	Spring Washer 4φ
154	1	1	1	1	1	1	427Z252020	Pad, Tonearm	217	1	1	1	1	1	1	53110403A9	Hexagon Nut M4
155	3	3	3	3	3	3	427Z118020	Spacer	218	1	1	1	1	1	1	54020301A0	Flat Washer P φ3
156	3	3	3	3	3	3	427Z010190	Screw, Transit	220	1	1	1	1	1	1	64000200R0	RG Ring, E Type φ2
157	2	2	2	2	2	2	427Z055010	Collar	221	1	1	1	1	1	1	64000300R0	RG Ring, E Type φ3
158	2	2	2	2	2	2	427Z010200	Screw, Transit	222	2	2	2	2	2	2	427Z010210	Screw φ2 x 12
159	1	1	1	1	1	1	ZD010002AR	Connective Cord									
160	1	1	1	1	1	1	427Z107030	Sheet									
161	1	1	1	1	1	1	427Z811010	Polyethy Bag									
162	1	1	1	1	1	1	427Z811020	Polyethy Bag									
163	1	1	1	1	1	1	427Z811030	Polyethy Bag									
164	1	1	1	1			427Z851310	Instructions									
164					1	1	427Z851210	Instructions									
165					1		427Z851010	Instructions, (Safety Inst.)									
166					1		427Z854010	Guarantee Card (U.S.A.)									
167					1		427Z854020	Guarantee Card (CANADA)									
168		1					427Z203010	Name Plate									
168					1		427Z203040	Name Plate									
168			1	1			427Z203020	Name Plate									
168	1						427Z203030	Name Plate									
168					1		427Z203050	Name Plate									
169	1	1	1	1	1	1	427Z861010	Label									
170	1	1	1	1	1	1	427Z861020	Label									

(W01-99)	Assembly and Wiring
(T01-99)	Adjustment
(X01-00)	Correction

To service personnel
 Make sure that only replacement parts recommended by the manufacturer should be used when the parts marked "⚠" in schematic diagram are exchanged.
 Never fail to make leakage-current or resistance measurements before returning the appliance to the customer so as to make sure that exposed parts are acceptably insulated from the supply circuit.



marantz®