

# Service Manual

UD8004 /K1B/S1B/N1B/U1B/R1B  
SUPER AUDIO CD/  
BLU-RAY DISC PLAYER

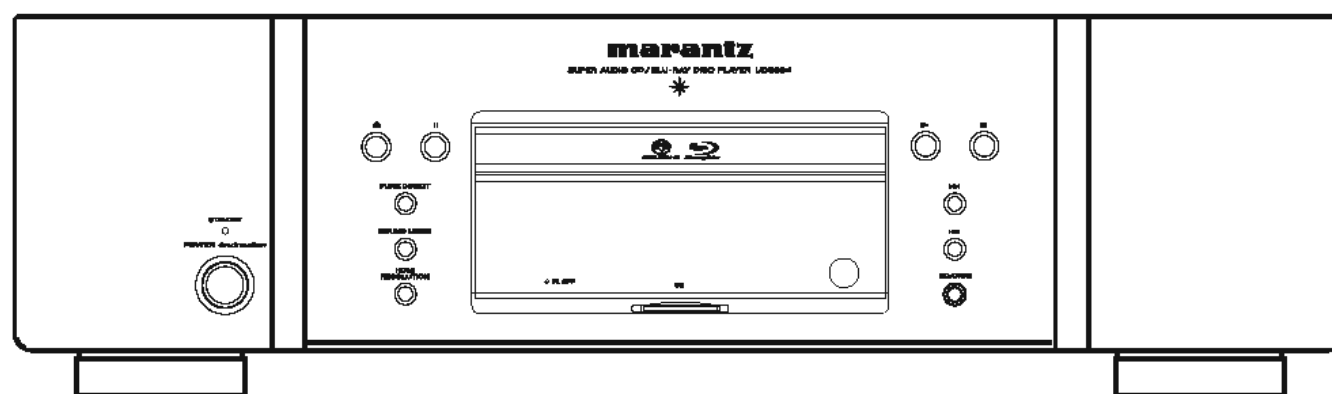

## TABLE OF CONTENTS

SECTION	PAGE
SERVICE HINTS AND TOOLS.....	ii
WARNING AND LASER SAFETY INSTRUCTIONS.....	iii
SPECIFICATIONS.....	1
WIRE ARRANGEMENT.....	2
DISASSEMBLY.....	3
DIAGNOSTICS OF OPTICAL PICKUP AND REPLACING FE MAIN P.W.B AND BD MECHANISM UNIT ASSY.....	12
SERVICE MODE.....	14
VERSION UPGRADE PROCEDURE OF FIRMWARE.....	25
TROUBLE SHOOTING.....	26
SEMICONDUCTORS.....	38
BLOCK DIAGRAM.....	51
PRINTED WIRING BOARDS.....	52
NOTE FOR PARTS LIST.....	59
PARTS LIST OF P.W.B. UNIT.....	60
WIRING DIAGRAM.....	97
EXPLODED VIEW.....	98
PARTS LIST OF EXPLODED VIEW.....	99
PACKING VIEW.....	101
PARTS LIST OF PACKING & ACCESSORIES.....	102
MEASURING METHOD AND WAVEFORMS.....	103
NOTE FOR SCHEMATIC DIAGRAM.....	108
SCHEMATIC DIAGRAMS.....	109

Please use this service manual with referring to the user guide ( D.F.U. ) without fail.  
修理の際は、必ず取扱説明書を準備し操作方法を確認の上作業を行ってください。

# marantz®

## UD8004

## MARANTZ DESIGN AND SERVICE

Using superior design and selected high grade components, **MARANTZ** company has created the ultimate in stereo sound. Only original **MARANTZ** parts can insure that your **MARANTZ** product will continue to perform to the specifications for which it is famous.

Parts for your **MARANTZ** equipment are generally available to our National Marantz Subsidiary or Agent.

### ORDERING PARTS :

Parts can be ordered either by mail or by Fax.. In both cases, the correct part number has to be specified.

The following information must be supplied to eliminate delays in processing your order :

1. Complete address
2. Complete part numbers and quantities required
3. Description of parts
4. Model number for which part is required
5. Way of shipment
6. Signature : any order form or Fax. must be signed, otherwise such part order will be considered as null and void.

#### USA

**MARANTZ AMERICA, INC**  
100 CORPORATE DRIVE  
MAHWAH, NEW JERSEY 07430  
USA

#### EUROPE / TRADING

**D&M EUROPE B. V.**  
P. O. BOX 8744, BUILDING SILVERPOINT  
BEEMDSTRAAT 11, 5653 MA EINDHOVEN  
THE NETHERLANDS  
PHONE : +31 - 40 - 2507844  
FAX : +31 - 40 - 2507860

#### CANADA

**D&M Canada Inc.**  
5-505 APPLE CREEK BLVD.  
MARKHAM, ONTARIO L3R 5B1  
CANADA  
PHONE : 905 - 415 - 9292  
FAX : 905 - 475 - 4159

#### JAPAN

**D&M Holdings Inc.**  
D&M BUILDING, 2-1 NISSHIN-CHO,  
KAWASAKI-KU, KAWASAKI-SHI,  
KANAGAWA, 210-8569 JAPAN

株式会社 ディーアンドエムホールディングス

本社 〒210-8569  
神奈川県川崎市川崎区日進町2-1 D&Mビル



#### KOREA

**D&M SALES AND MARKETING KOREA LTD.**  
CHUNG JIN B/D., #1001,  
53-5, WONHYORO 3 GA, YONGSAN-GU,  
SEOUL, 140-719, KOREA  
PHONE : +82 - 2 - 323 - 2155  
FAX : +82 - 2 - 323 - 2154

#### CHINA

**D&M SALES AND MARKETING SHANGHAI LTD.**  
ROOM.808 SHANGHAI AIRPORT CITY TERMINAL  
NO.1600 NANJING (WEST) ROAD, SHANGHAI,  
CHINA. 200040  
TEL : 021 - 6248 - 5151  
FAX : 021 - 6248 - 4434

### NOTE ON SAFETY :

Symbol  Fire or electrical shock hazard. Only original parts should be used to replaced any part marked with symbol . Any other component substitution (other than original type), may increase risk of fire or electrical shock hazard.

### 安全上の注意 :

がついている部品は、安全上重要な部品です。必ず指定されている部品番号のものを使用して下さい。

### SHOCK, FIRE HAZARD SERVICE TEST :

**CAUTION :** After servicing this appliance and prior to returning to customer, measure the resistance between either primary AC cord connector pins (with unit NOT connected to AC mains and its Power switch ON), and the face or Front Panel of product and controls and chassis bottom.

Any resistance measurement less than 1 Megohms should cause unit to be repaired or corrected before AC power is applied, and verified before it is return to the user/customer.

Ref. UL Standard No. 60065.

In case of difficulties, do not hesitate to contact the Technical Department at above mentioned address.

# SERVICE HINTS AND TOOLS

## 2. SERVICE HINTS AND TOOLS

### SERVICE HINTS

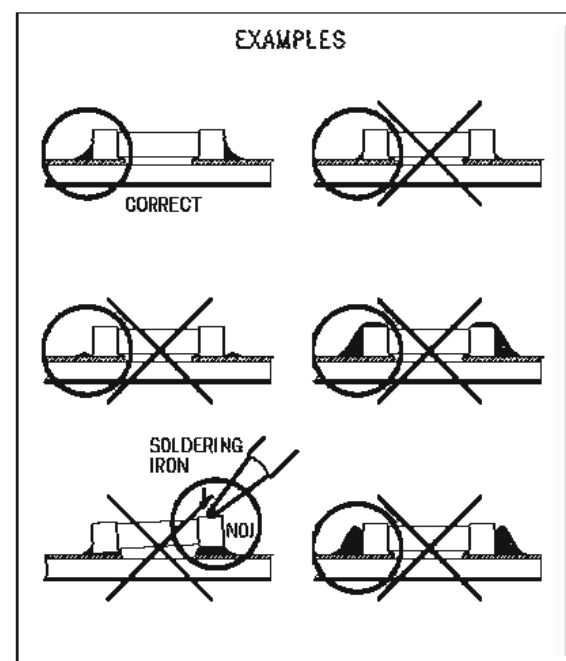
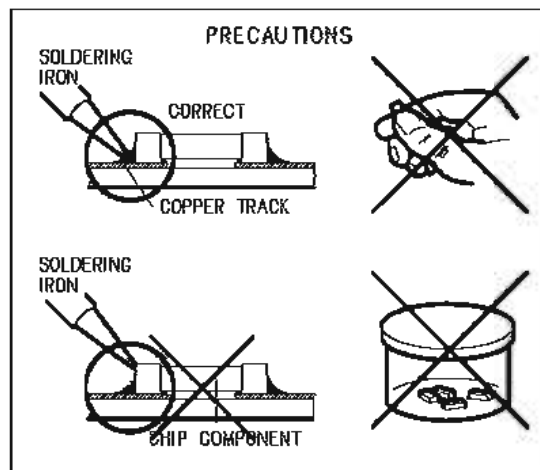
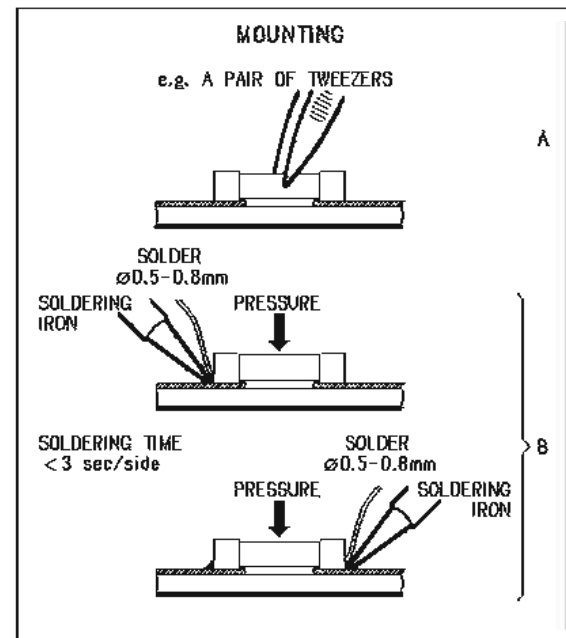
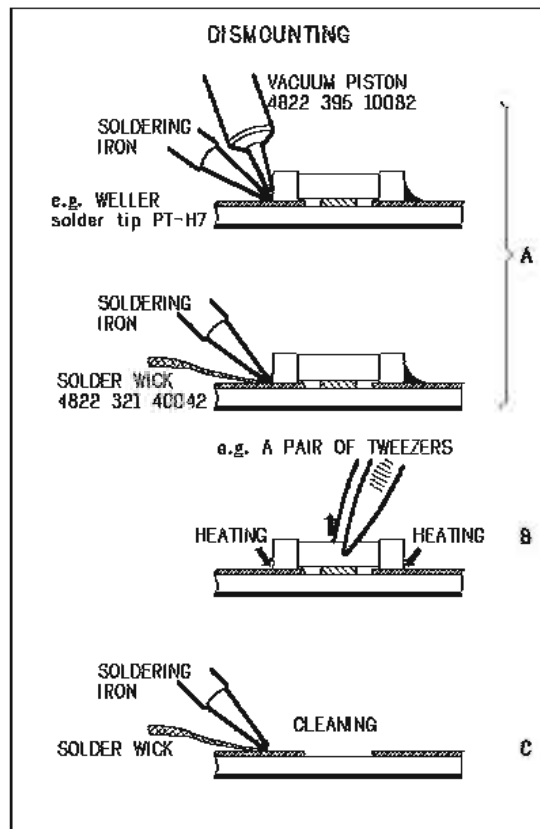
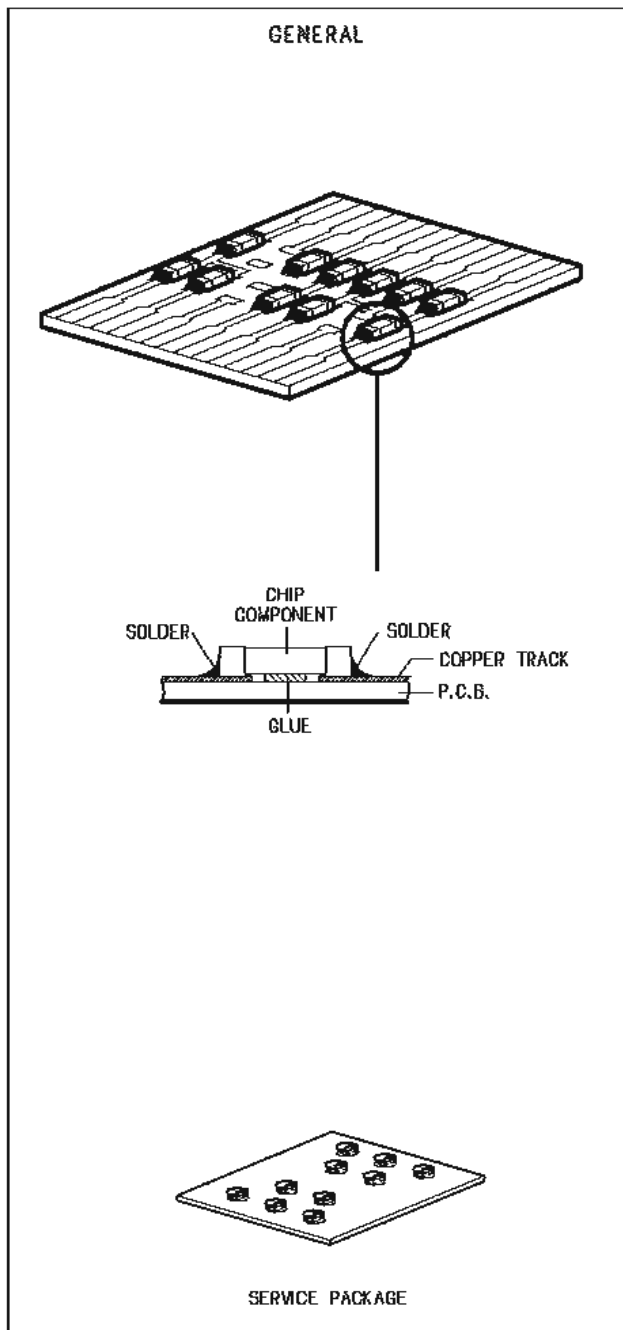

### SERVICE TOOLS

Audio signals disc	4822 397 30184 or TCD-784
Disc without errors +	
Disc with DO errors, black spots and fingerprints	4822 397 30245 (SBC444A) or TCD-726
Disc (65 min 1kHz) without no pause	4822 397 30155
Max. diameter disc (58.0 mm)	4822 397 60141
Torx screwdrivers	
Set (straight)	4822 395 50145
Set (square)	4822 395 50132
13th order filter	4822 395 30204
DVD test disc (PAL)	4822 397 10131
DVD test disc (NTSC) ALMEDIO	TDV-540

# WARNING AND LASER SAFETY INSTRUCTIONS

## **(GB)** WARNING

All ICs and many other semi-conductors are susceptible to electrostatic discharges (ESD). Careless handling during repair can reduce life drastically. When repairing, make sure that you are connected with the same potential as the mass of the set via a wrist wrap with resistance. Keep components and tools also at this potential.

ESD



## **(NL)** WAARSCHUWING

Alle IC's en vele andere halfgeleiders zijn gevoelig voor elektrostatische ontladingen (ESD). Onzorgvuldig behandelen tijdens reparatie kan de levensduur drastisch doen verminderen. Zorg ervoor dat u tijdens reparatie via een polsband met weerstand verbonden bent met hetzelfde potentiaal als de massa van het apparaat. Houd componenten en hulpmiddelen ook op ditzelfde potentiaal.

## **(F)** ATTENTION

Tous les IC et beaucoup d'autres semi-conducteurs sont sensibles aux décharges statiques (ESD). Leur longévité pourrait être considérablement écourtée par le fait qu'aucune précaution n'est prise à leur manipulation. Lors de réparations, s'assurer de bien être relié au même potentiel que la masse de l'appareil et enfilier le bracelet senti d'une résistance de sécurité. Veiller à ce que les composants ainsi que les outils que l'on utilise soient également à ce potentiel.

## **(D)** WARNUNG

Alle IC und viele andere Halbleiter sind empfindlich gegen elektrostatische Entladungen (ESD). Unvorsichtige Behandlung bei der Reparatur kann die Lebensdauer drastisch vermindern. Sorgen sie dafür, das Sie im Reparaturfall über ein Pulsarmband mit Widerstand mit dem Massepotential des Gerätes verbunden sind. Halten Sie Bauteile und Hilfsmittel ebenfalls auf diesem Potential.

## **(I)** AVVERTIMENTO

Tutti IC e parecchi semi-conduttori sono sensibili alle scariche statiche (ESD). La loro longevità potrebbe essere fortemente ridotta in caso di non osservazione della più grande cautela alla loro manipolazione. Durante le riparazioni occorre quindi essere collegato allo stesso potenziale che quello della massa dell'apparecchio tramite un braccialetto a resistenza. Assicurarsi che i componenti e anche gli utensili con quali si lavora siano anche a questo potenziale.

## **(GB)**

Safety regulations require that the set be restored to its original condition and that parts which are identical with those specified be used.

## **(D)**

Bei jeder Reparatur sind die geltenden Sicherheitsvorschriften zu beachten. Der Originalzustand des Gerats darf nicht verändert werden. Für Reparaturen sind Original-Ersatzteile zu verwenden.

## **(NL)**

Veiligheidsbepalingen vereisen, dat het apparaat in zijn oorspronkelijke toestand wordt terug gebracht en dat onderdelen, identiek aan de gespecificeerde worden toegepast.

## **(I)**

Le norme di sicurezza esigono che l'apparecchio venga rimesso nelle condizioni originali e che siano utilizzati pezzi di ricambio identici a quelli specificati.

## **(F)**

"Pour votre sécurité, ces documents doivent être utilisés par des spécialistes agréés, seuls habilités à réparer votre appareil en panne."

Les normes de sécurité exigent que l'appareil soit remis à l'état d'origine et que soient utilisées les pièces de rechange identiques à celles spécifiées.

## LASER SAFETY

This unit employs a laser. Only a qualified service person should remove the cover or attempt to service this device, due to possible eye injury.



USE OF CONTROLS OR ADJUSTMENTS OR PERFORMANCE OF PROCEDURE OTHER THAN THOSE SPECIFIED HEREIN MAY RESULT IN HAZARDOUS RADIATION EXPOSURE.

AVOID DIRECT EXPOSURE TO BEAM

## WARNING

The use of optical instruments with this product will increase eye hazard. Repair handling should take place as much as possible with a disc loaded inside the player

## WARNING LOCATION: INSIDE ON LASER COVERSHEILD

CAUTION VISIBLE AND INVISIBLE LASER RADIATION WHEN OPEN AVOID EXPOSURE TO BEAM  
ADVARSEL SYNLIG OG USYNLIG LASERSTRÅLING VED ÅBNING UNDGÅ UDSÆTTELSE FOR STRÅLING  
ADVARSEL SYNLIG OG USYNLIG LASERSTRÅLING NÅR DEKSEL Å PNES UNNGÅ EKSPONERING FOR STRÅLEN  
VARNING SYNLIG OCH OSYNLIG LASERSTRÅLNING NÅR DENNA DEL ÄR ÖPPNAD BETRakta EJ STRÅLEN  
VARO! AVATT AESSA OLET ALTTIINA NÄKYVÄLLE JA NÄKYMÄTTÖMÄLLE LASER SÄTEILYLLE ÄLÄ KATSO SÄTEESEEN  
VORSICHT SICHTBARE UND UNSICHTBARE LASERSTRÄHLUNG WENN ABDECKUNG GEÖFFNET NICHT DEM STRAHL AUSSETZEN  
DANGER VISIBLE AND INVISIBLE LASER RADIATION WHEN OPEN AVOID DIRECT EXPOSURE TO BEAM  
ATTENTION RAYONNEMENT LASER VISIBLE ET INVISIBLE EN CAS D'OUVERTURE EXPOSITION DANGEREUSE AU FAISCEAU

# SPECIFICATIONS

## □ Audio performance

Signal format : NTSC, PAL

Applicable discs /memory cards :

- (1) BD-Video discs :  
12 cm 1 side 1 layer, 12 cm 1 side 2 layers
- (2) DVD-Video / DVD-Audio discs :  
12 cm 1 side 1 layer, 12 cm 1 side 2 layers /  
12 cm 2 sides 2 layers (1 side 1 layer)  
8 cm 1 side 1 layer, 8 cm 1 side 2 layers /  
8 cm 2 sides 2 layers (1 side 1 layer)
- (3) Super Audio CDs :  
12 cm 1 layer / 12 cm 2 layer / 12 cm Hybrid
- (4) Compact Discs (CD-DA) :  
12 cm / 8 cm discs
- (5) Memory cards :  
SD Memory Card / SDHC Memory Card / miniSD Card /  
microSD Card

S-Video output :

Y output level : 1 Vp-p (75 Ω/ohms)  
C output level : 0.300 Vp-p  
Output terminal : S-Video, 1 set

Video output :

Output level : 1 Vp-p (75 Ω/ohms)  
Output terminal : Pin-jack, 1 set

Component video output :

Y output level : 1 Vp-p (75 Ω/ohms)  
Pb/Cb output level / Pr/Cr output level : 0.7 Vp-p (75 Ω/ohms)  
Output terminal : Pin-jack, 1 set

HDMI output :

Output terminal : 19-pin HDMI terminals, 1 set  
HDMI ver. 1.3a  
(Deep Colour, Dolby Digital Plus, Dolby TrueHD, DTS-HD)

Analog audio output :

Output level : 2.3 Vrms (10 kΩ/kohms)  
2 channels output terminal : Pin-jack, 1 set  
7.1 channels output terminal : Pin-jack, 1 set

Audio output characteristics :

- (1) Frequency response :
  - ①BD (Multi linear PCM): 2 Hz ~ 22 kHz (48 kHz sampling)  
: 2 Hz ~ 44 kHz (96 kHz sampling)  
: 2 Hz ~ 88 kHz (192 kHz sampling)
  - ②DVD (Multi linear PCM): 2 Hz ~ 22 kHz (48 kHz sampling)  
: 2 Hz ~ 44 kHz (96 kHz sampling)  
: 2 Hz ~ 88 kHz (192 kHz sampling)
  - ③Super Audio CD : 2 Hz ~ 100 kHz
  - ④Super Audio CD : 2 Hz ~ 20 kHz
- (2) S/N ratio : 120 dB
- (3) Total harmonic distortion : 1kHz 0.0015 %
- (4) Dynamic range : 110 dB
- (5) Channel separation : 110 dB

Digital audio output :

Optical digital output: Optical connector, 1 set  
Coaxial digital output: Pin jack, 1 set

## □ General

Power supply : AC 230 V, 50/60 Hz

Power consumption : 55W

- When in Power Saving Standby : 0.3 W
- When in Normal Standby : 0.8 W
- When in Quick Start Mode :  
20 ~ 35 W (Changes according to connection status, etc.)

## □ Dimensions

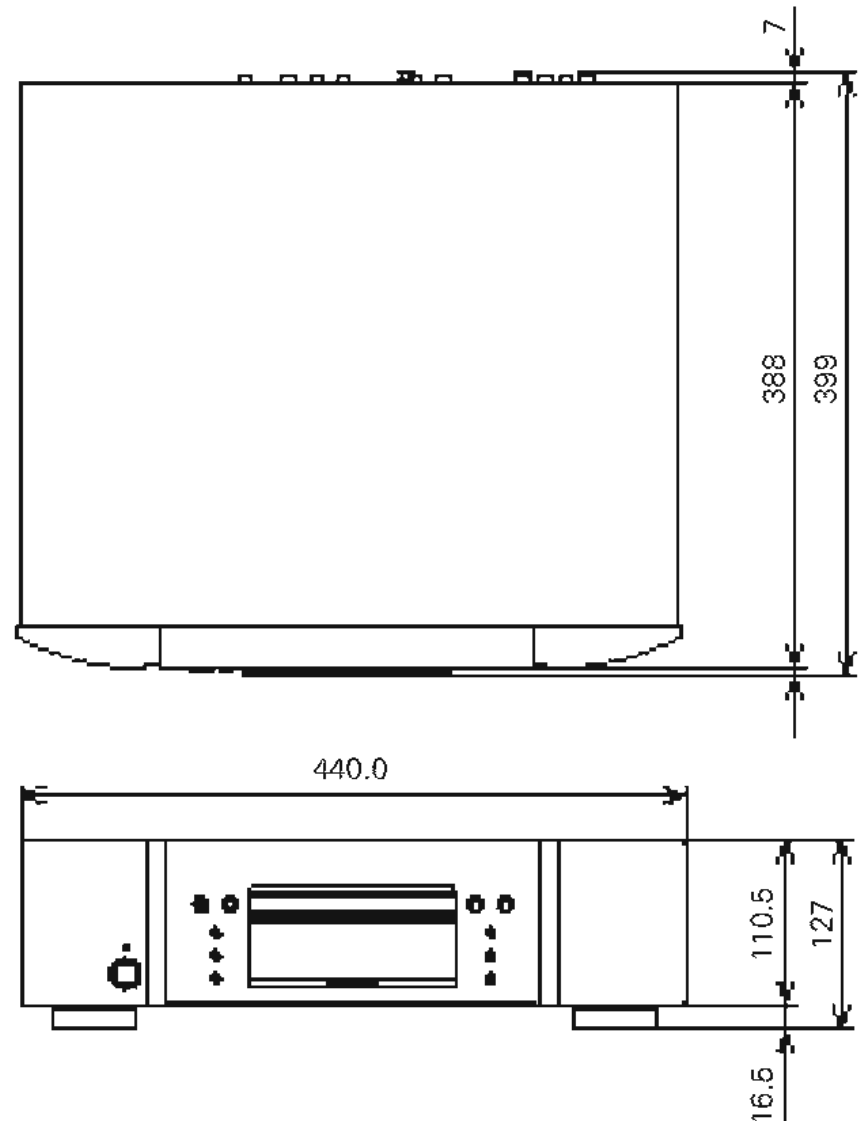

## □ Weight : 8.5 kg

\* For purposes of improvement, specifications and design are subject to change without notice.

## WIRE ARRANGEMENT

If wire bundles are untied or moved to perform an adjustment or parts replacement etc., be sure to rearrange them neatly as they were originally bundled or placed afterward. Otherwise, incorrect arrangement can be a cause of noise generation.

### Wire arrangement viewed from the top

Front Panel side



Back Panel side

# DISASSEMBLY

- Disassemble in order of the arrow of the figure of following flow.
- In the case of the re-assembling, assemble it in order of the reverse of the following flow.
- In the case of the re-assembling, observe "attention of assembling" it.

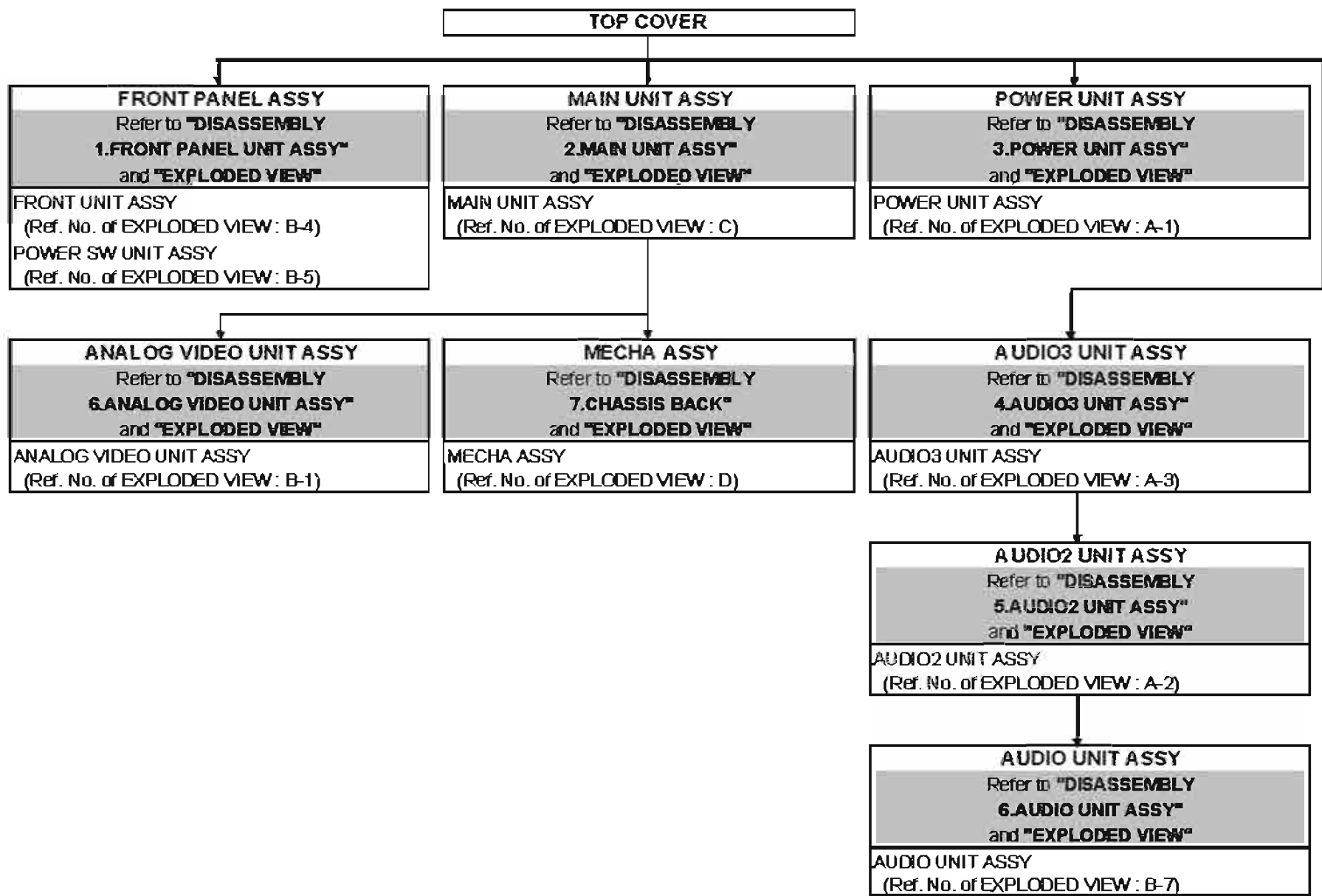

## About the photos used for descriptions in the "DISASSEMBLY" section.

- The direction from which the photographs used herein were photographed is indicated at "Direction of photograph: \*\*\*" at the left of the respective photographs.
- Refer to the table below for a description of the direction in which the photos were taken.
- Photographs for which no direction is indicated were taken from above the product.
- The photograph is UD8004.

The viewpoint of each photograph  
(Photography direction)

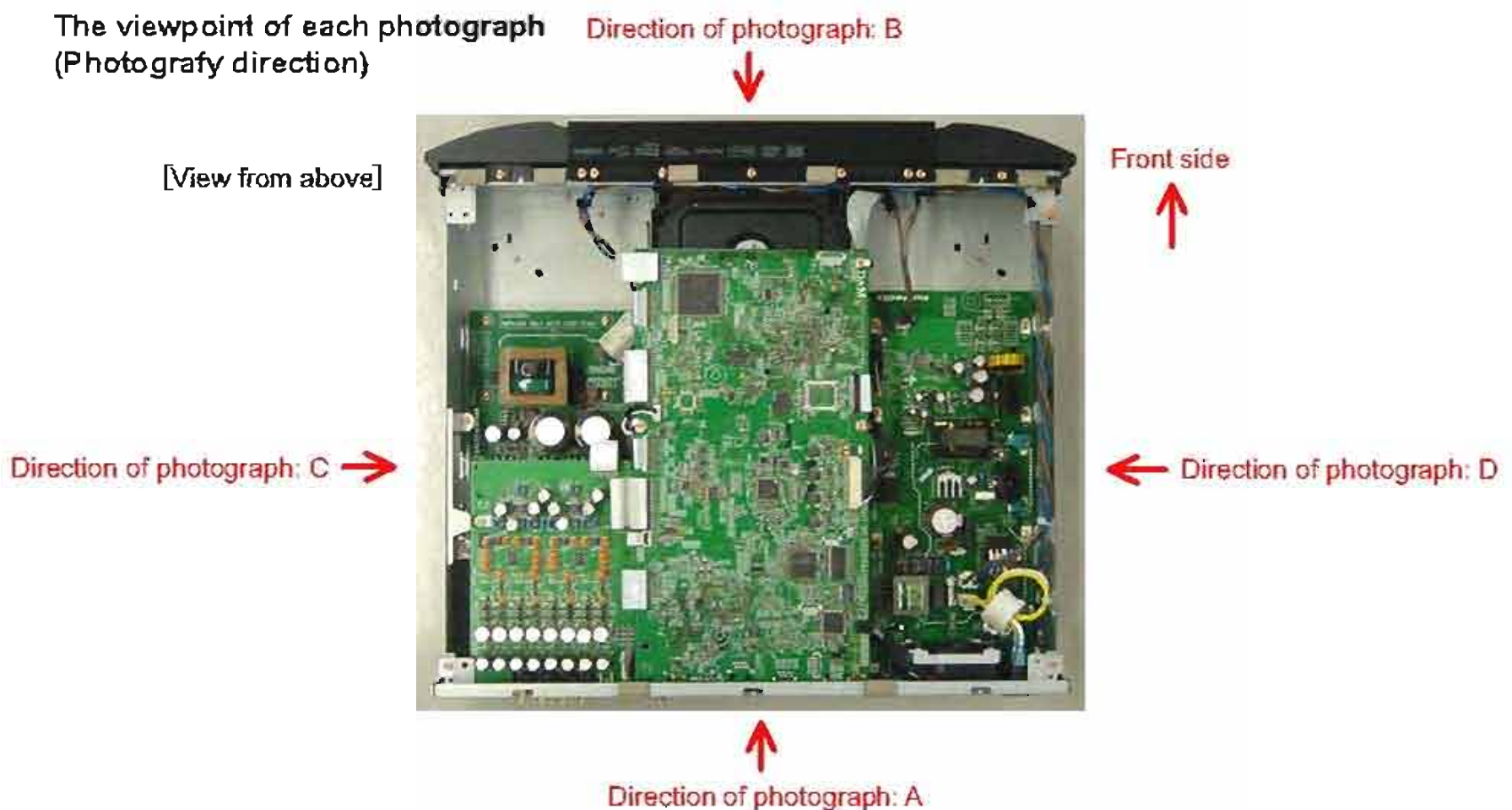

# 1. FRONT PANEL ASSY

Proceeding : **TOP COVER** → **LOADER PANEL** → **FRONT PANEL ASSY**

(1) Remove the Loader Panel.



(2) Remove the screws.



(3) Cut the wire clampers. Disconnect the connector wire and FFC Cable.

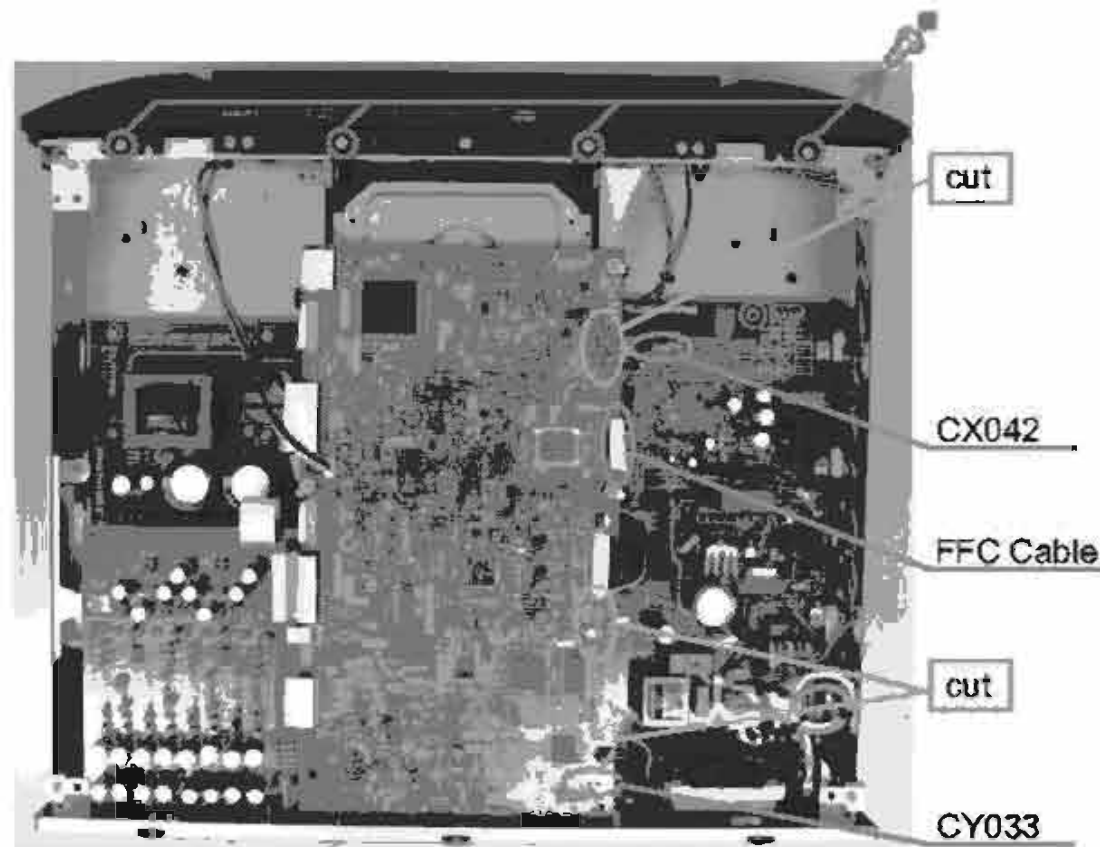

Please refer to "EXPLODED VIEW" for the disassembly method of each P.W.B included in FRONT PANEL ASSY.



## 2. MAIN UNIT SUB ASSY

Proceeding : **TOP COVER** → **MAIN UNIT ASSY**

(1) Remove the screws.

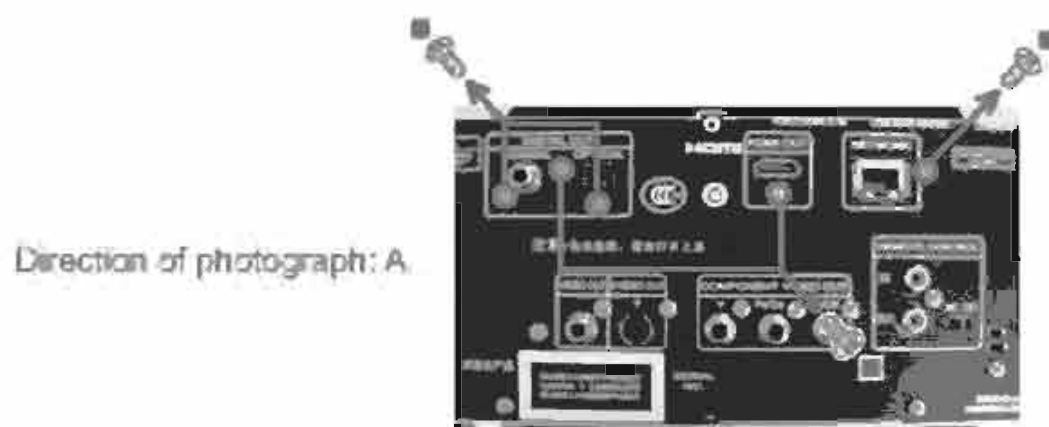

(2) Remove the screws. Disconnect the connector wires and FFC cables.

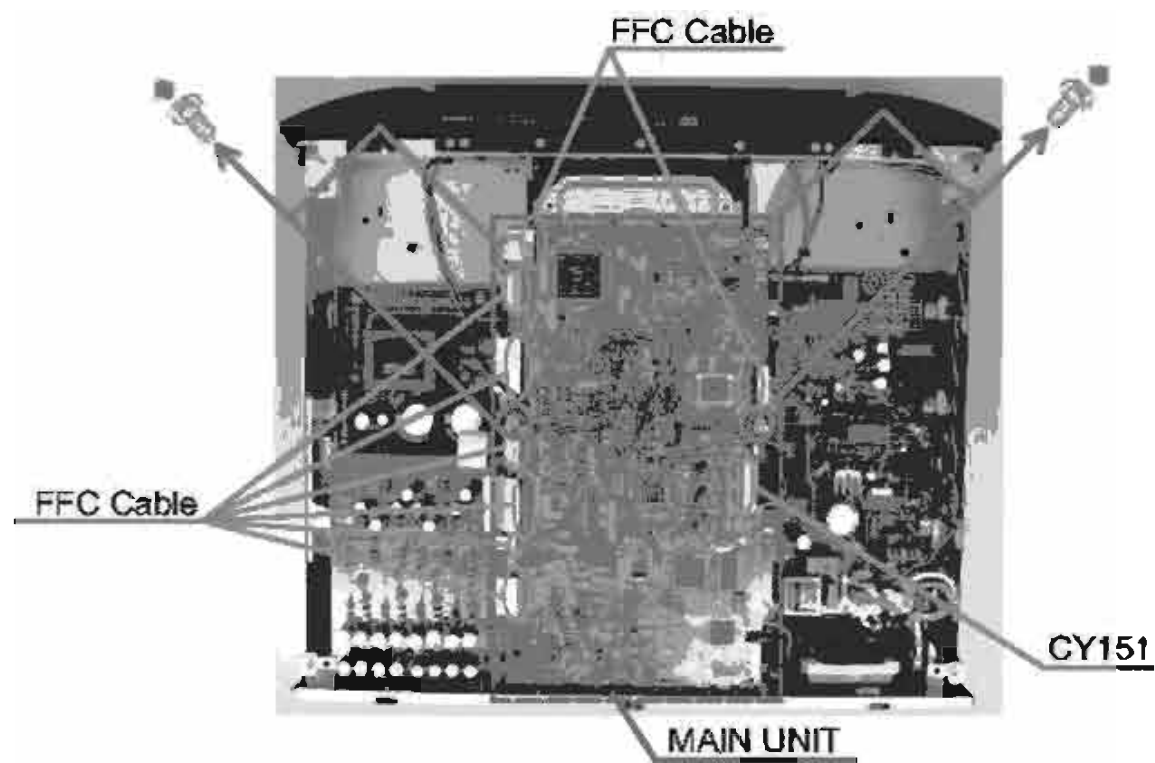

### 3. POWER UNIT ASSY

Proceeding : **TOP COVER** → **POWER UNIT ASSY**

(1) Remove the screws.

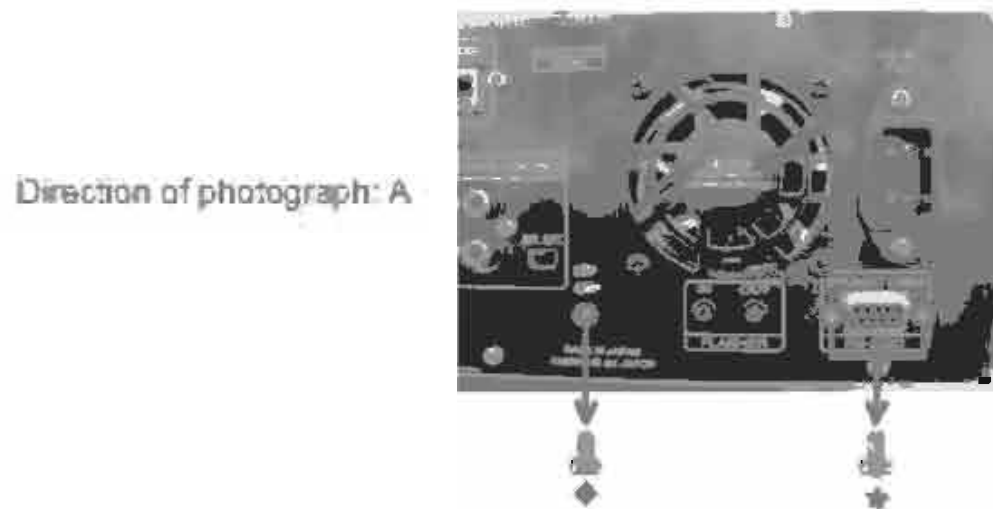

(2) Remove the screws. Disconnect the connector wire.

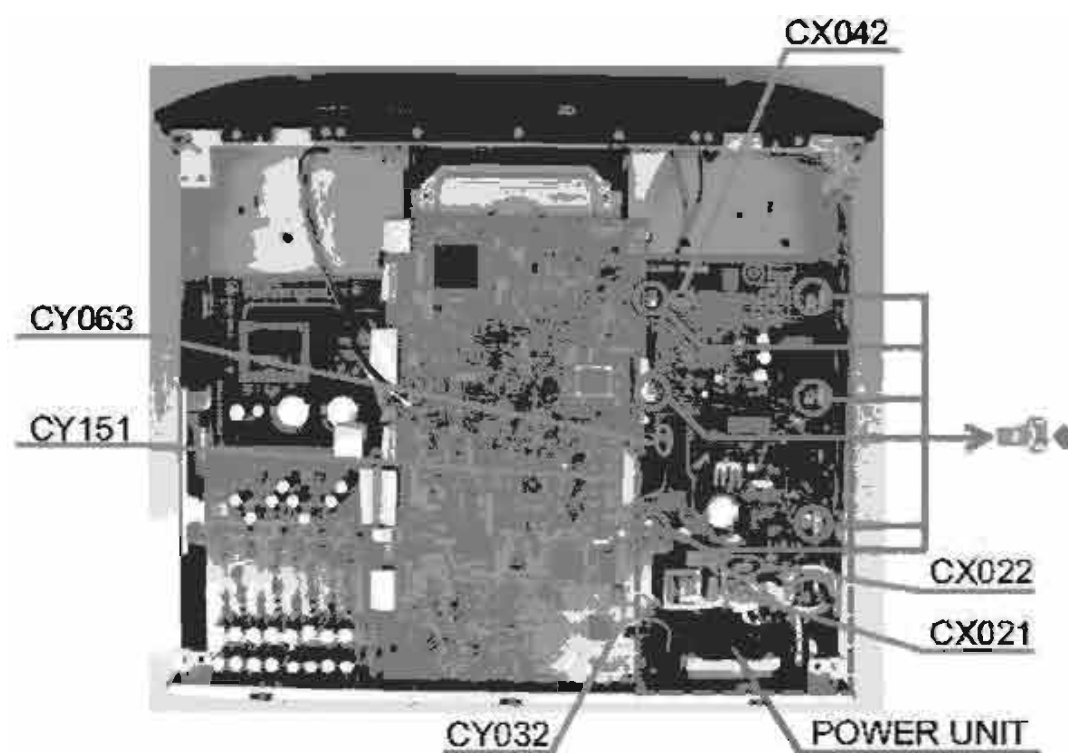

#### 4. AUDIO3 UNIT ASSY

Proceeding : **TOP COVER** → **AUDIO3 UNIT ASSY**

(1) Remove the screws.



(2) Remove the screws. Disconnect the HOCK, connector wire and FFC Cable.

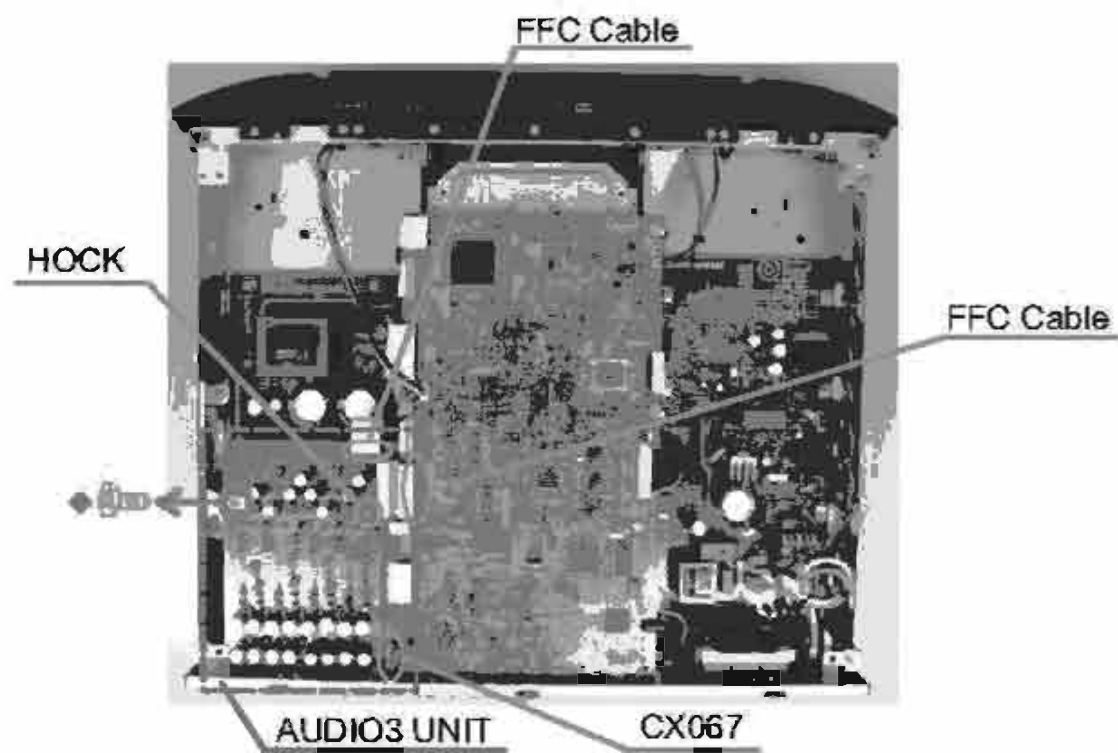

## 5. AUDIO2 UNIT ASSY

Proceeding : **TOP COVER** → **AUDIO3 UNIT ASSY** → **AUDIO2 UNIT ASSY**

(1) Remove the screws.



(2) Remove the screws. Disconnect the HOCK, connector wire and FFC Cable.

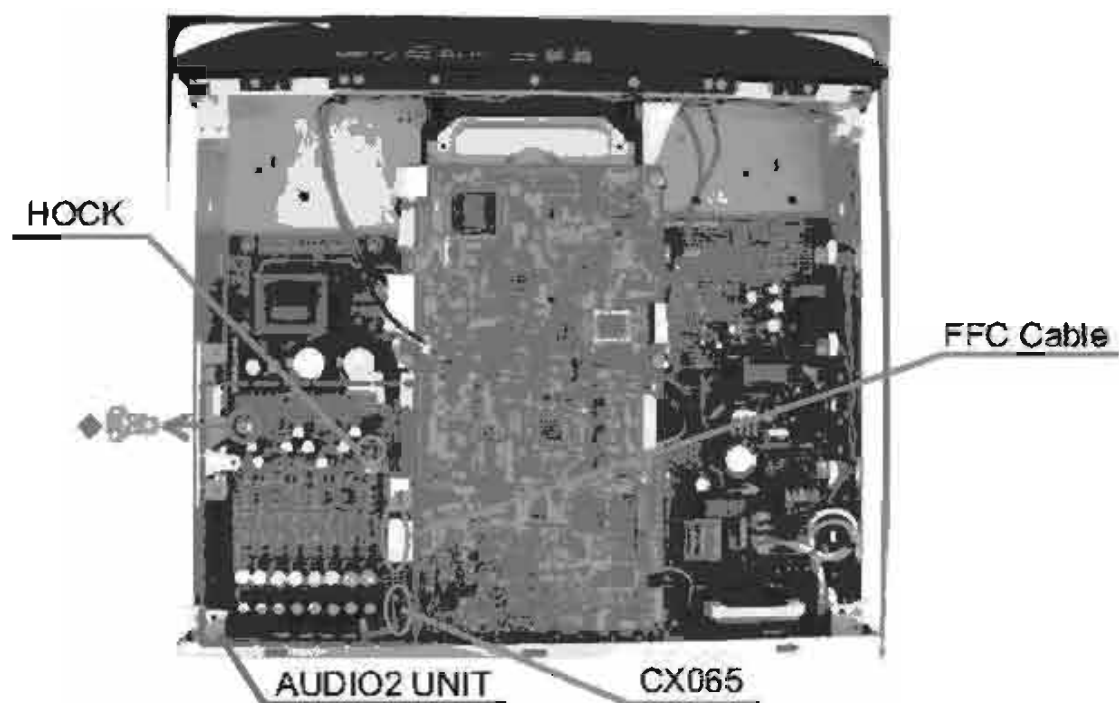

## 6. AUDIO UNIT ASSY

Proceeding : **TOP COVER** → **AUDIO3 UNIT ASSY** → **AUDIO2 UNIT ASSY**  
→ **AUDIO UNIT ASSY**

(1) Remove the screws.

Direction of photograph: A



(2) Remove the screws.

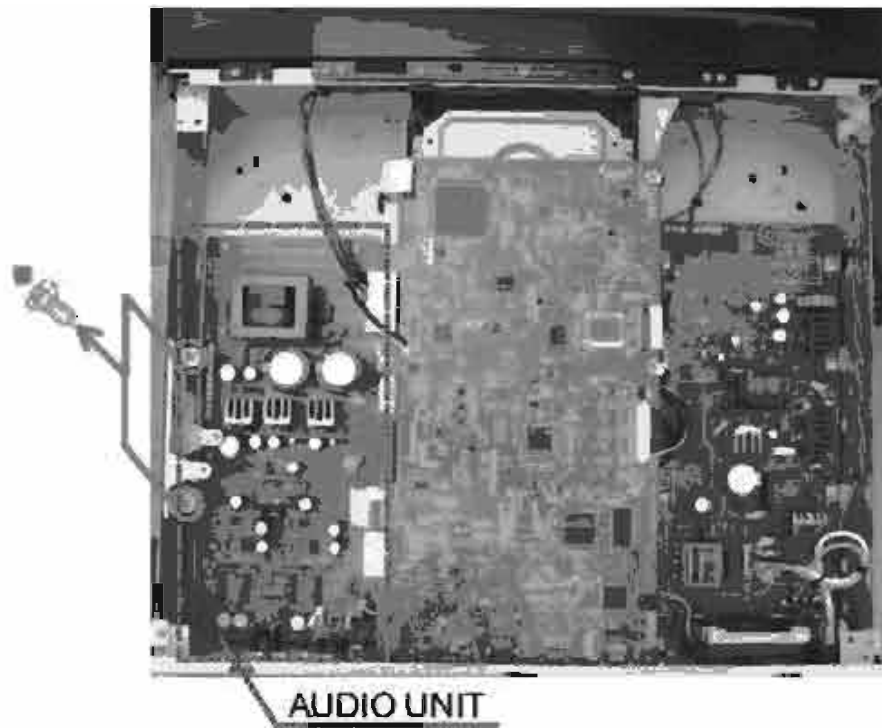

(3) Remove the screws.



## 7. ANALOG VIDEO UNIT ASSY

Proceeding : **TOP COVER** → **MAIN UNIT ASSY** → **ANALOG VIDEO UNIT ASSY**

(1) Remove the screws.

Direction of photograph: A



(2) Remove the screws.

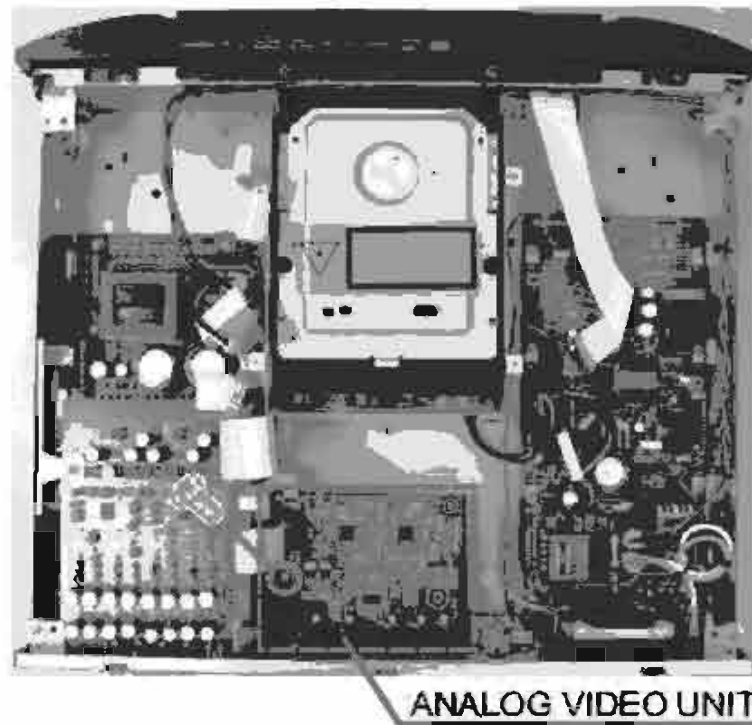

## 8. MECHA ASSY

Proceeding : **TOP COVER** → **MAIN UNIT ASSY** → **MECHA ASSY**

(1) Remove the screws. Disconnect the connector wire.



## Removing discs

Proceeding : **INSIDE PLATE** → **SLIDE CAM**

(1) Remove the screws and FOOTs.

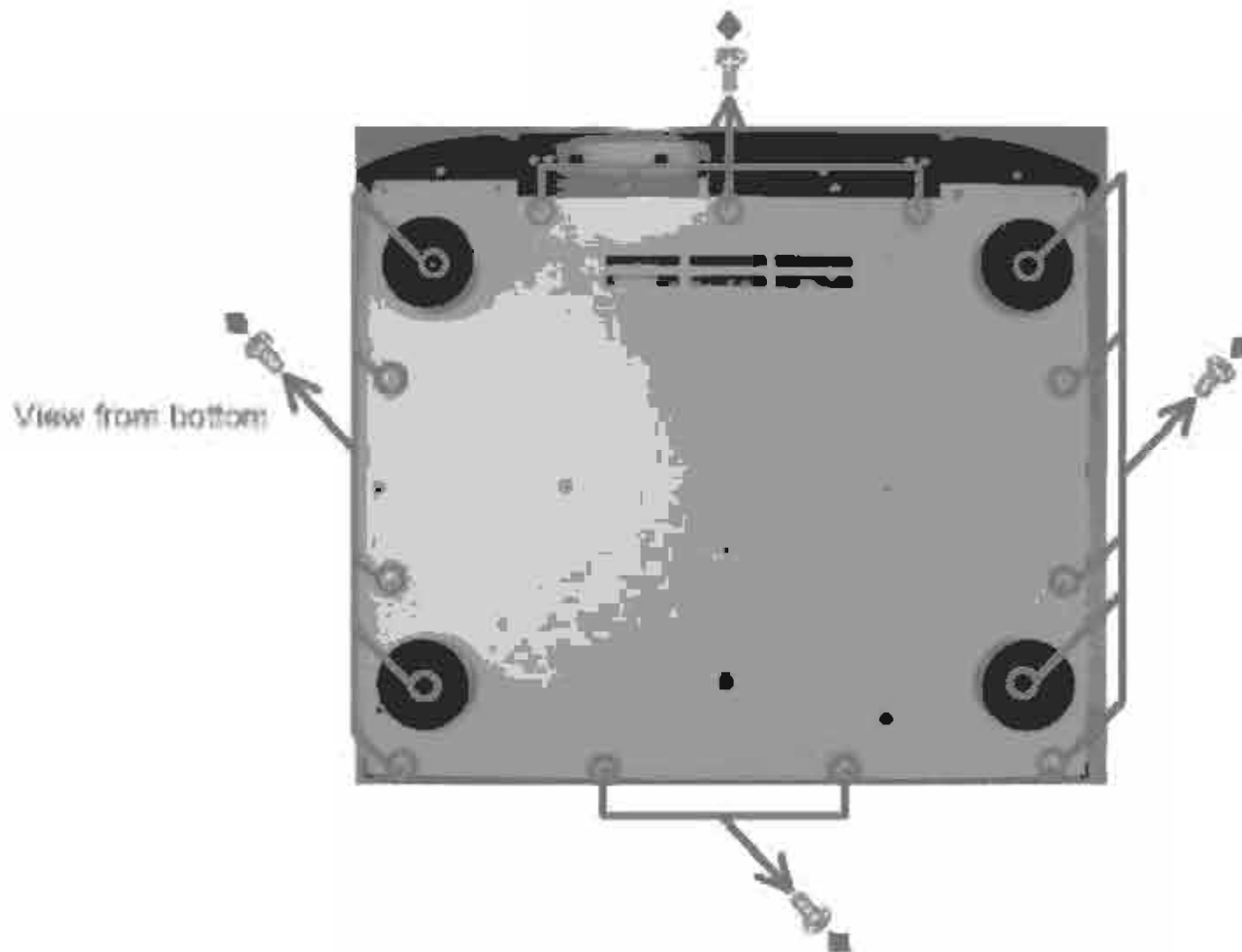

(2) Slide the SLIDE CAM in the direction of the arrow.



(3) Draw out the LOADER TRAY, then remove the disc.

# DIAGNOSTICS OF OPTICAL PICKUP AND REPLACING FE MAIN P.W.B AND BD MECHANISM UNIT ASSY

Make failure diagnostics of the Optical Pickup as follows.

If the laser drive current (Iop) becomes more than  $\pm 12$ [mA] of the initial value, the Optical Pickup should be replaced.

The laser drive current initial value is checked by "Iop checked Method" of next page.

In case of replacing the Pickup, change the whole part of the FE Main P.W.B and BD Mechanism Unit Assy.

No mechanical adjustment is necessary after the replacement.

## Laser drive current initial value:

**CD:**

FL Display (The display part of 13 digits)												
1	2	3	4	5	6	7	8	9	10	11	12	13
T	2	1	-	m	m	m	m	-	n	n	n	n

**DVD:**

FL Display (The display part of 13 digits)												
1	2	3	4	5	6	7	8	9	10	11	12	13
T	2	2	-	m	m	m	m	-	n	n	n	n

**BD(SL):**

FL Display (The display part of 13 digits)												
1	2	3	4	5	6	7	8	9	10	11	12	13
T	2	3	-	m	m	m	m	-	n	n	n	n

**BD(DL):**

FL Display (The display part of 13 digits)												
1	2	3	4	5	6	7	8	9	10	11	12	13
T	2	4	-	m	m	m	m	-	n	n	n	n

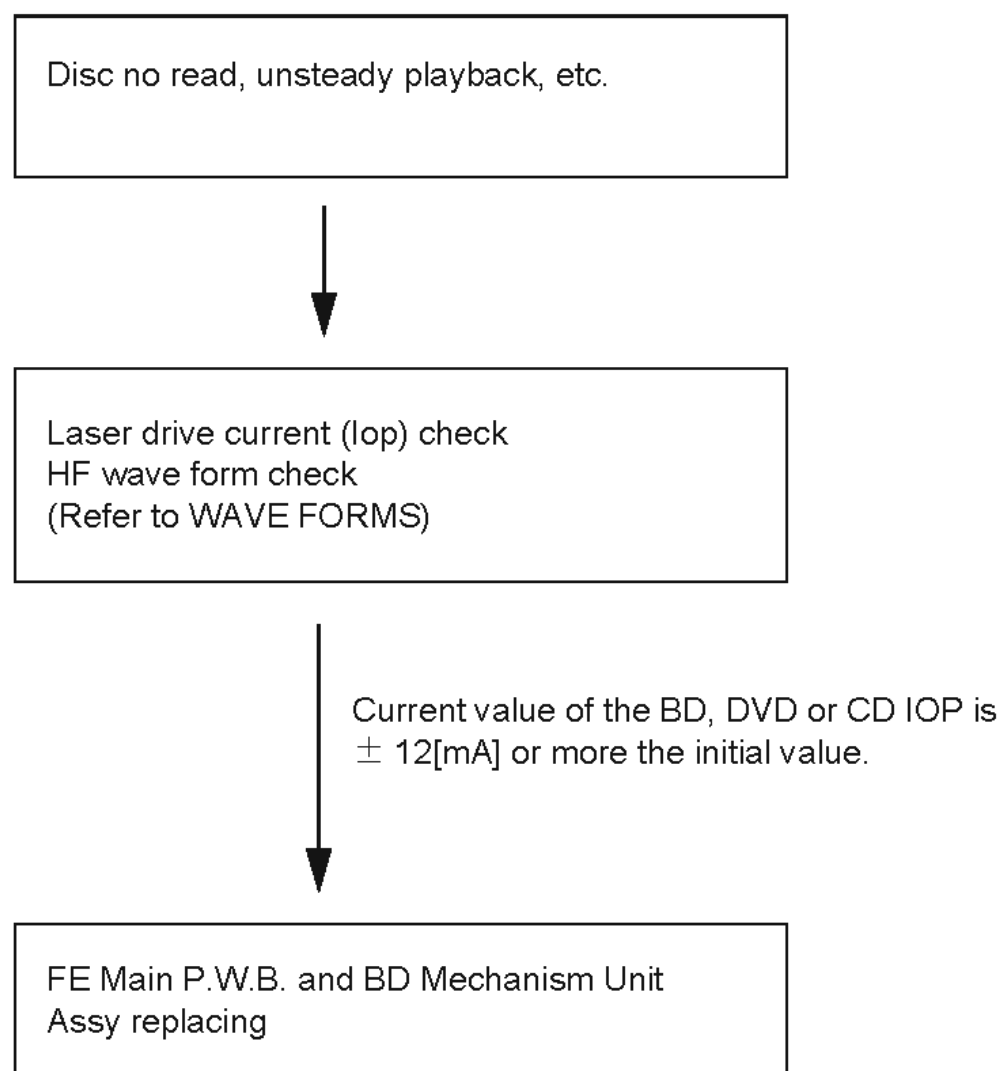



## 1. IOP checked Method

Select the laser ON/OFF(CD/DVD/BD)mode of the test mode, and check the IOP value of CD laser, DVD laser or BD laser.

(See page 19 for test mode.)

FL Display (The display part of 13 digits)												
1	2	3	4	5	6	7	8	9	10	11	12	13
T	2		L	a	s	e	r	O	n	O	f	f

### DVD laser current check

Press the **◀◀** or **▶▶** button to display the laser current value, and then select [X].

Check the current value of IOP (nnnn)

FL Display (The display part of 13 digits)												
1	2	3	4	5	6	7	8	9	10	11	12	13
T	2	X	---	n	n	n	n	---	n	n	n	n

(X=1 : CD laser mode, 2 : DVD laser mode, 3 : BD(SL) laser mode, 4 : BD(DL) laser mode)  
(nn.nn[mA] : Current value)

## 2. To clear the accumulated laser on time

Press the **▶** button while the accumulated laser on time is displayed ("TC1", "TC2", "TC3") until "\*" appears at the fourth position. Press the **◀◀** or **▶▶** button to select "TC4". If the **▶** button is pressed while "TC1" is displayed, the accumulated laser on time of CD, DVD and BD is cleared

FL Display (The display part of 13 digits)												
1	2	3	4	5	6	7	8	9	10	11	12	13
T	C	4	*	---	---	---	---	---	---	---	---	---

When "TC1", "TC2" or "TC3" is selected with the **◀◀** or **▶▶** button, "mmmmmm" is displayed as "0" so you can check.

FL Display (The display part of 13 digits)												
1	2	3	4	5	6	7	8	9	10	11	12	13
T	C	Y	---	---	---	n	n	n	n	n	n	n

(Y=1 : CD, 2 : DVD, 3 : BD, mmmmmm : Time(Fractions of hours are counted up one hour on the display.)

# SERVICE MODE

## 1. Heat run mode

### 1.1. preparation

- (1) Equipment used : Heat run disc (This operation may not work with any discs other than the heat run discs listed below.)  
CD : CD TEST DISC (TCD-HR01)  
DVD : DVD TEST DISC (TDV-HR01)  
BD : BD TEST DISC (TBD-HR01)
- (2) Unit setting : No spec other than the following procedure.

### 1.2. procedure

#### <Playback mode>

- (1) Pressing the ▲ and ► buttons simultaneously, plug the AC cord into a power outlet.  
When the heat run mode is set, the "►" and "■" indicators light.
- (2) Press the ▲ button and open a tray.
- (3) Set a disc to the tray and press the ► button once. The "►" and "■" indicators blink at the same time and heat run operation starts.  
DVD : After playback title-1 and title-10 of the disc, the tray opens and closes automatically, then playback the title-1 and title-10 again.  
CD/BD : The disc is played through once from title 1 through the last title, the tray opens and closes automatically, then the disc is played through again from title 1 through the last title.
- (4) This heat run operation continues automatically or it stops caused by an error. In case of some error, the following error messages are displayed on the FL tube.

#### <Tray open/close mode>

- (1) Pressing the ▲ and ► buttons simultaneously, plug the AC cord into a power outlet.  
When the heat run mode is set, the "►" and "■" indicators light.
- (2) Press the ▲ button and open a tray.
- (3) Set a disc to the tray and press the ► button twice. The "►" and "■" indicators blinks alternately and heat run operation starts.  
CD/DVD/BD : After disc loading is complete, the tray opens and closes automatically, and disc loading is carried out again.
- (4) This heat run operation continues automatically or it stops caused by an error. In case of some error, the following error messages are displayed on the FL tube.
- ※ If the PURE DIRECT button is pressed during heat run, the repeat count of heat run operations is displayed as (Cnt \*\*\*\*\*). Press the PURE DIRECT button once more and the display returns to its original state.

No.	Error contents	FL display
1	Tray Error	ERROR 01
2	Bad Disc	ERROR 02
3	Search Error	ERROR 03
4	Read Error	ERROR 04
5	Communications error	ERROR 05
6	Other (Front end error)	ERROR 06

## 2. Initial setting mode

### 2.1. preparation

- (1) Equipment used: None
- (2) Unit setting: No spec other than the following procedure.

### 2.2. procedure

- ※ Initialize the BD player when  $\mu$ com, peripheral parts of  $\mu$ com, or MAIN P.W.B. unit has been replaced in servicing.
  - ※ All user setting will be lost and its factory setting will be restored when this initialization is made. Be sure to memorize your setting for restoring again after the initialization.
- (1) Turn on the UD8004's power. "NO DISC" is displayed on the fluorescent tube.
  - (2) Press the UD8004's PLAY, EJECT and SOUND MODE buttons simultaneously. "INITIALIZING" is displayed on the fluorescent tube.
  - (3) The display on the fluorescent tube switches to "INITIALIZED", the "NO DISC" display reappears and initialization is completed.

## 3. $\mu$ com firm, H/W version, and Sereal number mode

### 3.1. preparation

- (1) Equipment used: None
- (2) Unit setting: No spec other than the following procedure.

### 3.2. procedure

- ※ System  $\mu$ com and other  $\mu$ com firm check mode.  
This mode is for displaying the status of each  $\mu$ com employed.
- (1) Pressing the  $\blacktriangle$  and  $\blacktriangleright$  buttons simultaneously, plug the AC cord into a power outlet.
  - (2) "NO DISC" is displayed on the fluorescent tube.
  - (3) Press remote contraller "3265".
  - (4) Each time the POP UP MENU button or Cursor buttons( $\blacktriangle$  or  $\blacktriangledown$ ) on the remote control unit is pressed, version information of  $\mu$ com firm, version of H/W and serial number is displayed one after another.  
Ex.: [Sys Ver000103, Sys Day090219, Sys GEN100000....., H/W Ver000000, S/N \*\*\*\*\*]

## 4. Tray lock mode

### 4.1. preparation

- (1) Equipment used: None
- (2) Unit setting: No spec other than the following procedure.

### 4.2. procedure

#### [Setting]

- (1) Pressing the  $\blacktriangleright$  and  $\blacksquare$  buttons for simultaneously, plug the AC cord into a power outlet.
- (2) "TRAY LOCK" is displayed on the fluorescent tube and tray opening/closing is invalidated.

#### [Cancel]

- (1) Unplug the UD8004's AC cord from the power outlet.
  - (2) Pressing the  $\blacktriangleright$  and  $\blacksquare$  buttons simultaneously, plug the AC cord into a power outlet.
  - (3) "PLEASE WAIT" is displayed on the fluorescent tube and tray opening/closing is enabled.
- ※ The tray lock mode is also canceled when the product is initialized.

## 5. All Lit / All Off mode for the FL tube

### 5.1. preparation

- (1) Equipment used: None
- (2) Unit setting: No spec other than the following procedure.

### 5.2. procedure

#### [Setting]

- (1) Pressing the HDMI RESOLUTION and ► buttons for simultaneously, plug the AC cord into a power outlet.  
If All Lit / All Off mode is set for the FL tube, the FL tube's display area is fully lit.
- (2) Press the Pure Direct button to switch between 'all lit' and 'all off' display.

#### [Cancel]

- (1) Remove the power cable for 5 seconds or more to cancel All Lit / All Off mode for the FL tube.

## 6. Forced Tray Open mode.

### 7.1. preparation

- (1) Equipment used: None
- (2) Unit setting: No spec other than the following procedure.

※ Operation cannot be guaranteed after executing Forced Tray Open mode.

### 6.2. procedure

#### [Setting]

- (1) To forcibly open the tray, press the ▲ for 5 seconds or more.

#### [Cancel]

- (1) Remove the power cable for 5 seconds or more to cancel Forced Tray Open mode.

## 7. Test mode

### 7.1. Entering the test mode

The test mode is entered by pressing the ▲ and ■ buttons simultaneously, plug the AC cord into a power outlet. When the test mode is set, the "▶" and "■" indicators light.

FL tube display when test mode entered

FL Display (The display part of 13 digits)												
1	2	3	4	5	6	7	8	9	10	11	12	13
		T	E	S	T		M	O	D	E		

When the test mode is set, a color bar appears on the monitor.

### 7.2. Selecting the mode

• The following modes are available.

- (1) Laser on/off (CD/DVD/BD) mode : T2
- (2) Servo adjustment value display mode : T3
- (3) Error rate (skew) measurement mode : T7
- (4) Accumulated laser on time display mode : TC
- (5) Track buffer output mode : TE
- (6) Picking up No. display mode : TG
- (7) Error log display mode : TH
- (8) Test mode cancel : TI

① When the ▶▶ button is pressed after entering the test mode, the display switches in the order: "T2, T3, T7, TC, TE, TG, TH, TI, T2 ..."

FL Display (The display part of 13 digits)												
1	2	3	4	5	6	7	8	9	10	11	12	13
T	2		L	a	s	e	r	O	n	O	f	f

FL Display (The display part of 13 digits)												
1	2	3	4	5	6	7	8	9	10	11	12	13
T	3		S	e	r	v	o		A	d	J	.

FL Display (The display part of 13 digits)												
1	2	3	4	5	6	7	8	9	10	11	12	13
T	7		E	r	r	o	r		R	a	t	e

FL Display (The display part of 13 digits)												
1	2	3	4	5	6	7	8	9	10	11	12	13
T	C		L	a	s	e	r	O	n	T	i	m

FL Display (The display part of 13 digits)												
1	2	3	4	5	6	7	8	9	10	11	12	13
T	E		T	r	a	c	k		B	u	f	

FL Display (The display part of 13 digits)												
1	2	3	4	5	6	7	8	9	10	11	12	13
T	G		O	P	U		N	U	n	b	e	r

FL Display (The display part of 13 digits)												
1	2	3	4	5	6	7	8	9	10	11	12	13
T	H		E	r	r	o	r		L	o	g	

FL Display (The display part of 13 digits)												
1	2	3	4	5	6	7	8	9	10	11	12	13
T	I		T	e	s	t		E	x	i	t	

② When the ◀◀ button is pressed, the display switches in the opposite order fromq above, starting from the current position (for example, if currently at "TA", it switches as follows: "T2, T3, T7, TC, TE, TG, TH, TI, T2 ...").

### 7.3. About each mode

- With the mode selected, press the ► button to set that mode.

#### (1) Laser on/off (CD/DVD/BD) mode

Press the ◀◀ or ▶▶ button to select [X] and press the 1 button to set it. Laser on/off control is executed and the laser current is displayed.

FL Display (The display part of 13 digits)												
1	2	3	4	5	6	7	8	9	10	11	12	13
T	2	X		m	m	m	m		n	n	n	n

(X=1 : CD laser mode, 2 : DVD laser mode, 3 : BD(SL) laser mode, 4 : BD(DL) laser mode)  
(mm.mm[mA] : Stored data, nn.nn[mA] : Current value)

- ※ When the current value is more that ± 12.00[mA] of saved data, it becomes the pickup transducer's target. In this case, replace the mechanism unit.

If stored value is not

FL Display (The display part of 13 digits)												
1	2	3	4	5	6	7	8	9	10	11	12	13
T	2	X	—	—	—	—	—	—	n	n	n	n

(X=1 : CD laser mode, 2 : DVD laser mode, 3 : BD(SL) laser mode, 4 : BD(DL) laser mode)  
(nn.nn[mA] : Current value)

When the ■ button is pressed, the layer above the current layer is displayed. See "7.4 Stopping the mode" (page 21).

#### (2) Servo adjustment value display mode

Press the ◀◀ or ▶▶ button to select [XXX]. Refer to [Table 1 - Servo adjustment value display mode details] (page 21).

FL Display (The display part of 13 digits)												
1	2	3	4	5	6	7	8	9	10	11	12	13
T	X	X	X									

(XXX : Servo adjustment value)

Press the ► button to set. The contents indicated on "Table 1: Details of the servo adjustment value display mode" (page 21) are displayed.

FL Display (The display part of 13 digits)												
1	2	3	4	5	6	7	8	9	10	11	12	13
T	X	X	X	m	m	m	m	m	m		n	n

(XXX : Selection mode, mmmmmm : Address(HEX), nn:Data(HEX))

The first time, the address specification position is the uppermost position (5th place). The address specification position moves downwards each time the ► button is pressed.

The address specification position flashes (at an interval of about 0.5 seconds). If the 1 button is pressed after moving to the lowermost position (10th place), the position moves to the uppermost position

Use the ◀◀ or ▶▶ button to change the display at the address specification position.

When the ■ button is pressed, the layer above the current layer is displayed. See "7.4 Stopping the mode" (page 21).

(3) Error rate measurement mode

Press the **◀◀** or **▶▶** button to select [YY] .  
 Refer to [Table 2 - Error rate details]. (page 22)

FL Display (The display part of 13 digits)												
1	2	3	4	5	6	7	8	9	10	11	12	13
T	Y	Y	F	F	F	F	F	F	F	F	F	F

(X : measurement mode, F : Address and error rate (When not set, "F" is displayed.)

Press the **▶** button to begin error rate measurement. The address and error rate are displayed.  
 For a description of the displayed measurement results, see "Table 2: Error rate details" (page 22).

FL Display (The display part of 13 digits)												
1	2	3	4	5	6	7	8	9	10	11	12	13
T	Y	Y	m	m	m	m	m	m				

(YY : selection mode [71 to 94], m : address [PBA][HEX], | : error rate [COUNT/SEC] [HEX])

- (Note) CD (4x-speed) : Renewal of data is carried out for every 300 frame.  
 Error rate of 75 frames is displayed.
- DVD (2x-speed) : Renewal of data is carried out for every 80ECC block.  
 Error rate of 8ECC block is displayed.
- BD (2x-speed) : Renewal of data is carried out for every 136LDC clusters block.  
 Error rate of 8LDC clusters block is displayed.

The mode chosen when selection mode was changed into the trace execution and the **▶** button was pushed is performed from the beginning.

When the **▶** button is pushed without changing selection mode, the mode under selection is performed from the beginning.

(If the **▶** button is pushed, the address corresponding to the chosen mode will be searched again.)

The pause mode is set after tracing is completed.

When the **■** button is pressed, the layer above the current layer is displayed. See "7.4 Stopping the mode" (page 21).

(4) Accumulated laser on time display mode

Press the **◀◀** or **▶▶** button to select [Y] and press the **▶** button to set it.  
 The accumulated laser on time is displayed.

FL Display (The display part of 13 digits)												
1	2	3	4	5	6	7	8	9	10	11	12	13
T	C	Y				m	m	m	m	m	m	h

(Y=1 : CD, 2 : DVD , 3 : BD, mmmmmm : Time(Fractions of hours are counted up one hour on the display.)

When the **■** button is pressed, the layer above the current layer is displayed. See "7.4 Stopping the mode" (page 21)

---To clear the accumulated laser on time---

Press the **▶** button while the accumulated laser on time is displayed ("TC1, "TC2", "TC3" ) until " \* " appears at the fourth position.

FL Display (The display part of 13 digits)												
1	2	3	4	5	6	7	8	9	10	11	12	13
T	C	Y	*				m	m	m	m	m	m

Press the **◀◀** or **▶▶** button to select "TC4"

FL Display (The display part of 13 digits)												
1	2	3	4	5	6	7	8	9	10	11	12	13
T	C	4	*									

If the **▶** button is pressed while "TC4" is displayed, the accumulated laser on time of CD, DVD and BD is cleared.

FL Display (The display part of 13 digits)												
1	2	3	4	5	6	7	8	9	10	11	12	13
T	C	1				0	0	0	0	0	0	h

When "TC1", "TC2" or "TC3" is selected with the **◀◀** or **▶▶** button, "mmmmmm" is displayed as "0" so you can check.

(5) Track buffer output mode

Press the ◀◀ or ▶▶ button to select "Y" and switch the track buffer output.

FL Display (The display part of 13 digits)												
1	2	3	4	5	6	7	8	9	10	11	12	13
T	E	Y	T	r	a	c	k		B	u	f	f

(Y=1 : Track buffer being output, 0 : Track buffer output off)

When the ■ button is pressed, the layer above the current layer is displayed. See "7.4 Stopping the mode" (page 21).

(6) Picking up No. display mode

Press the ◀◀ or ▶▶ button to switch to the pickup number display.  
The pickup number is a 14-digit number, so it is displayed in two sections.

FL Display (The display part of 13 digits)												
1	2	3	4	5	6	7	8	9	10	11	12	13
T	G	X		Y	Y	Y	Y	Y	Y	Y		

(X (display position) = 1 : Lower digits, 2 : Upper digits. YYYYYYYY: Pickup number)

When the ■ button is pressed, the layer above the current layer is displayed. See "7.4 Stopping the mode" (page 21).

(7) Error log display mode

Press the ◀◀ or ▶▶ button to switch to the error log display.  
For Error log No. and description of the displayed measurement results, see "Table 3: Error log details" (page 24).

FL Display (The display part of 13 digits)												
1	2	3	4	5	6	7	8	9	10	11	12	13
n	T	H	X									

(n : Error information No.(1 ~ 5), X : Error log No.)

Display when there is no error

FL Display (The display part of 13 digits)												
1	2	3	4	5	6	7	8	9	10	11	12	13
n	T	H	I		N	O		E	R	R	O	R

When the ■ button is pressed, the layer above the current layer is displayed. See "7.4 Stopping the mode" (page 21).

(8) Test mode cancel

A confirmation message is displayed. Press the ▶ button to set, canceling the test mode.

FL Display (The display part of 13 digits)												
1	2	3	4	5	6	7	8	9	10	11	12	13
T	I	I		R	e	a	I	I	Y	?		

When the ■ button is pressed, the layer above the current layer is displayed. See "7.4 Stopping the mode" (page 21).



## 7.4. Stopping the mode

When the ■ button is pressed, the layer above the current layer is displayed. The relationship between the different modes and the display of the different layers is shown on the table below.

Mode	1 layer	2 layer	3 layer
Laser on/off (CD/DVD/BD) mode	T2 LaserOnOff	T2X mmmm nnnn	Non
Servo adjustment value display mode	T3 Servo Adj.	TXXX	TXXXmmmmmm nn
Error rate (skew) measurement mode	T7 Error Rate	TYYYYYYYYY	TYmmmmmmllll
Accumulated laser on time display mode	TC LaserOnTim	TCY mmmmmmh	TCY* mmmmmmh TC4*
Track buffer output mode	TE Track Buf	TEYTrack Buff	Non
Picking up No. display mode	TG OPU Number	TGX YYYYYYY	Non
Error log display mode	TH Error Log	nTHX nTH1 No Error	nTHX ddddd nTHAyyy dddd
Test mode cancel	TI Test Exit	TI1 Really?	Non

## 7.5. About the OPEN/CLOSE (5)button

Even during the test mode, the tray is opened and closed when the ▲ button is pressed.

## 7.6. Test mode detailed table

Table 1: Servo adjustment value display mode details

No	XXX	Name	Address range	Meaning
0	T30	BUF_ID_SDRAM	0x000000 ~ 0x3FFFFFF	SDRAM
1	T31	BUF_ID_MPU_ALL	0x000000 ~ 0xBEFF3F	MPU(Abs Access)
2	T32	BUF_ID_MPU_RMCR	0x000000 ~ 0x00FFFF	ROMCOR
3	T33	BUF_ID_MPU_SYSCFG	0x000000 ~ 0x000FFF	SystemConfiguration
4	T34	BUF_ID_MPU_DMACH	0x000000 ~ 0x0004FF	DMACH
5	T35A	BUF_ID_MPU_ITIM0	0x000000 ~ 0x0000FF	ITIM 0
6	T35B	BUF_ID_MPU_ITIM1	0x000000 ~ 0x0000FF	ITIM 1
7	T35C	BUF_ID_MPU_ITIM2	0x000000 ~ 0x0000FF	ITIM 2
8	T35D	BUF_ID_MPU_ITIM3	0x000000 ~ 0x0000FF	ITIM 3
9	T35E	BUF_ID_MPU_ITIM4	0x000000 ~ 0x0000FF	ITIM 4
10	T35F	BUF_ID_MPU_ITIM5	0x000000 ~ 0x0000FF	ITIM 5
11	T36	BUF_ID_MPU_RSV2	0x000000 ~ 0x0079FF	Reserved
12	T37	BUF_ID_MPU_WDT	0x000000 ~ 0x000FFF	WDT
13	T38	BUF_ID_MPU_UART0	0x000000 ~ 0x0000FF	UART 0
14	T39	BUF_ID_MPU_UART1	0x000000 ~ 0x0000FF	UART 1
15	T40	BUF_ID_MPU_CSIO0	0x000000 ~ 0x0000FF	CSIO 0
16	T41	BUF_ID_MPU_CSIO1	0x000000 ~ 0x0000FF	CSIO 1
17	T42	BUF_ID_MPU_GPIO0	0x000000 ~ 0x0000FF	GPIO 0
18	T43	BUF_ID_MPU_GPIO1	0x000000 ~ 0x0000FF	GPIO 1
19	T44	BUF_ID_MPU_GPIO2	0x000000 ~ 0x0000FF	GPIO 2
20	T45	BUF_ID_MPU_RSV5	0x000000 ~ 0x00BCFF	Reserved
21	T46	BUF_ID_MPU_HEXBIU	0x000000 ~ 0x000FFF	HEXBIU
22	T47	BUF_ID_MPU_HCSC	0x000000 ~ 0x000FFF	HCSC
23	T48	BUF_ID_MPU_RSV6	0x000000 ~ 0x7DDFFF	Reserved
24	T49	BUF_ID_MPU_RSV7	0x000000 ~ 0x3DFEFF	Reserved
25	T50	BUF_ID_MPU_INT	0x000000 ~ 0x00003F	INT
26	T51	BUF_ID_IRAM	0x000000 ~ 0x003FFF	IRAM(internal SRAM))
27	T52	BUF_ID_DSP	0x000000 ~ 0x001FFF	DSP Register
28	T53	BUF_ID_AFE	0x000000 ~ 0x0000FF	AFE Register
29	T54	BUF_ID_SVO_ALL	0x000000 ~ 0x001FFF	SVO REG ABS ACCESS
30	T55	BUF_ID_SVO_REG	0x000000 ~ 0x0007FF	SVERVO REG

No	XXX	Name	Address range	Meaning
31	T56	BUF_ID_SVO_SVRAM	0x000000 ~ 0x0005FF	SVRAM
32	T57A	BUF_ID_SVO_CRAM0	0x000000 ~ 0x0001FF	CRAM0
33	T57B	BUF_ID_SVO_CRAM1	0x000000 ~ 0x0001FF	CRAM1
34	T57C	BUF_ID_SVO_CRAM2	0x000000 ~ 0x0001FF	CRAM2
35	T57D	BUF_ID_SVO_CRAM3	0x000000 ~ 0x0001FF	CRAM3
36	T58A	BUF_ID_SVO_ZRAM0	0x000000 ~ 0x0001FF	ZRAM0
37	T58B	BUF_ID_SVO_ZRAM1	0x000000 ~ 0x0001FF	ZRAM1
38	T58C	BUF_ID_SVO_ZRAM2	0x000000 ~ 0x0001FF	ZRAM2
39	T58D	BUF_ID_SVO_ZRAM3	0x000000 ~ 0x0001FF	ZRAM3
40	T59	BUF_ID_EPRM	0x000000 ~ 0x000FFF	EEPROM
41	T60	BUF_ID_PUCONT_LDD	0x000000 ~ 0x000007	LDD
42	T61	BUF_ID_SVRESULT	0x000000 ~ 0x0002C3	SvResult
43	T62	BUF_ID_LD_TIME	0x000000 ~ 0x00000D	LD ON Time Integrated value
44	T63	BUF_ID_IOP	0x000000 ~ 0x000007	IOP(Stored value)

Table 2: Error rate details

YY	Measurement position	Error rate display details for each media type			Remarks
		BD	DVD	CD	
71	The inner circumference of 1-layer	BIS error detection signed number	It is invalid.	It is invalid.	When this is selected for DVD or CD, it shifts to YY=73.
72	The inner circumference of 1-layer	BIS error uncorrectable signed numbe	It is invalid.	It is invalid.	When this is selected for DVD or CD, it shifts to YY=73.
73	The inner circumference of 1-layer	LDC error detection signed number	PI error detection number	C1 error detection number	
74	The inner circumference of 1-layer	LDC error uncorrectable signed numbe	PO uncorrectable error number	C2 uncorrectable error number	
75	The central circumference of 1-layer	BIS error detection signed number	It is invalid.	It is invalid.	When this is selected for DVD or CD, it shifts to YY=77.
76	The central circumference of 1-layer	BIS error uncorrectable signed numbe	It is invalid.	It is invalid.	When this is selected for DVD or CD, it shifts to YY=77.
77	The central circumference of 1-layer	LDC error detection signed number	PI error detection number	C1 error detection number	
78	The central circumference of 1-layer	LDC error uncorrectable signed numbe	PO uncorrectable error number	C2 uncorrectable error number	
79	The outer circumference of 1-layer	BIS error detection signed number	It is invalid.	It is invalid.	When this is selected for DVD or CD, it shifts to YY=81.
80	The outer circumference of 1-layer	BIS error uncorrectable signed numbe	It is invalid.	It is invalid.	When this is selected for DVD or CD, it shifts to YY=81.
81	The outer circumference of 1-layer	LDC error detection signed number	PI error detection number	C1 error detection number	
82	The outer circumference of 1-layer	LDC error uncorrectable signed numbe	PO uncorrectable error number	C2 uncorrectable error number	

YY	Measurement position	Error rate display details for each media type			Remarks
		BD	DVD	CD	
83	The inner circumference of 2-layer	BIS error detection signed number	It is invalid.	It is invalid.	When this is selected for 2-layer DVD, it shifts to YY=85. When this is selected for 1-layer DVD or CD, it shifts to YY=73.
84	The inner circumference of 2-layer	BIS error uncorrectable signed number	It is invalid.	It is invalid.	When this is selected for DVD 2-layer, it shifts to YY=85. When this is selected for DVD 1-layer or CD, it shifts to YY=73.
85	The inner circumference of 2-layer	LDC error detection signed number	PI error detection number	It is invalid.	When this is selected for 1-layer DVD or CD, it shifts to YY=73.
86	The inner circumference of 2-layer	LDC error uncorrectable signed number	PO uncorrectable error number	It is invalid.	When this is selected for 1-layer DVD or CD, it shifts to YY=73.
87	The central circumference of 2-layer	BIS error detection signed number	It is invalid.	It is invalid.	When this is selected for DVD 2-layer, it shifts to YY=89. When this is selected for DVD 1-layer or CD, it shifts to YY=77.
88	The central circumference of 2-layer	BIS error uncorrectable signed number	It is invalid.	It is invalid.	When this is selected for DVD 2-layer, it shifts to YY=89. When this is selected for DVD 1-layer or CD, it shifts to YY=77.
89	The central circumference of 2-layer	LDC error detection signed number	PI error detection number	It is invalid.	When this is selected for DVD 1-layer or CD, it shifts to YY=77.
90	The central circumference of 2-layer	LDC error uncorrectable signed number	PO uncorrectable error number	It is invalid.	When this is selected for DVD 1-layer or CD, it shifts to YY=77.
91	The outer circumference of 1-layer	BIS error detection signed number	It is invalid.	It is invalid.	When this is selected for DVD 2-layer, it shifts to YY=93. When this is selected for DVD 1-layer or CD, it shifts to YY=81.
92	The outer circumference of 1-layer	BIS error uncorrectable signed number	It is invalid.	It is invalid.	When this is selected for DVD 2-layer, it shifts to YY=93. When this is selected for DVD 1-layer or CD, it shifts to YY=81.
93	The outer circumference of 1-layer	LDC error detection signed number	PI error detection number	It is invalid.	When this is selected for DVD 1-layer or CD, it shifts to YY=81.
94	The outer circumference of 1-layer	LDC error uncorrectable signed number	PO uncorrectable error number	It is invalid.	When this is selected for DVD 1-layer or CD, it shifts to YY=81.

\* The inner circumference of the layer refers to the physical inner circumference for DVD parallel, the physical outer circumference for the opposite case.

\* The inner circumference of the layer refers to the physical outer circumference for DVD parallel, the physical inner circumference for the opposite case.

Table 3: Error log details

Error log No.	Contents (Error log overall layout)	Remarks
1	LD On Time (4Byte)	
2	Error type (2Byte)	See "Table 3-1: Error type details"
3 (31 to 34 displayed in 4-byte units)	Reserve (16Byte)	
4	Media type (2Byte)	See "Table 3-2: Media type details"
5	Reserve (4Byte)	
6	Reserve (4Byte)	
7	Reserve (2Byte)	
8	HyBrid SOUND MODE (2Byte)	See "Table 3-3: HyBrid Disc current layer details"
9 (91 to 92 displayed in 7-digit units) (Matched to TG pickup number display)	PU# (16Byte)	
A (A000 to A161 displayed in 2-digit units)	Reserve (708Byte)	
B (B1 to B3 displayed in 4-digit units)	Reserve (11Byte)	
C	Reserve (1Byte)	
D (D1 to D3 displayed in 4-digit units)	Reserve (12Byte)	

Table 3-1: Error type details

Error type	Error code
NoError	0x0000
Focus does not turn on.	0x0001
Tracking does not turn on.	0x0002
CLV does not turn on.	0x0003
ID cannot be read.	0x0004
Loader error	0x0005
Thread error	0x0006
Expander error	0x0007
Other error	0x0008
Error disc (Failure to recognition of disc)	0x0009
Seek error	0x0010
Lead error	0x0020
Other	Reserved

Table 3-2: Media type details

Media type	Media code
DVD-ROM	0x0001
DVD-R	0x0002
DVD-RW	0x0003
DVD-PLUS-R	0x0004
DVD-PLUS-RW	0x0005
DVD-ROM DL	0x0006
DVD+R DL	0x0007
DVD-R DL	0x0008
DVD+RW DL	0x0009
DVD-RW DL	0x000A
CD-ROM	0x000B
CD-R	0x000C
CD-RW	0x000D
BD-RE SL	0x000E
BD-RE DL	0x000F
BD-R SL	0x0010
BD-R DL	0x0011
BD-R SL LTH	0x0012
BD-ROM SL	0x0013
BD-ROM DL	0x0014
BD-Hybrid	0x0015
SACD-Hybrid	0x0016
SACD DL	0x0017
SACD SL	0x0018
DVD-Hybrid	0x0019
Unknown	0xFFFF
Other	Reserved

Table 3-3: HyBrid Disc current layer details

HyBrid Disc current layer	Current layer code
SACD layer	0x0000
CD layer	0x0001
DVD layer	0x0002
BD layer	0x0003
Other	Reserved

# VERSION UPGRADE PROCEDURE OF FIRMWARE

You can update by downloading the latest firmware from the Internet.  
To update the IP ROM, refer to "Updating the IP ROM" on page 30.

## 1. Update from the Internet

### 1.1. Connecting to the Network

#### (1) System Requirement

- Internet Connection by Broadband Circuit
- Modem
- Router
- Ethernet cable (CAT-5 or greater recommended)

#### (2) Setting

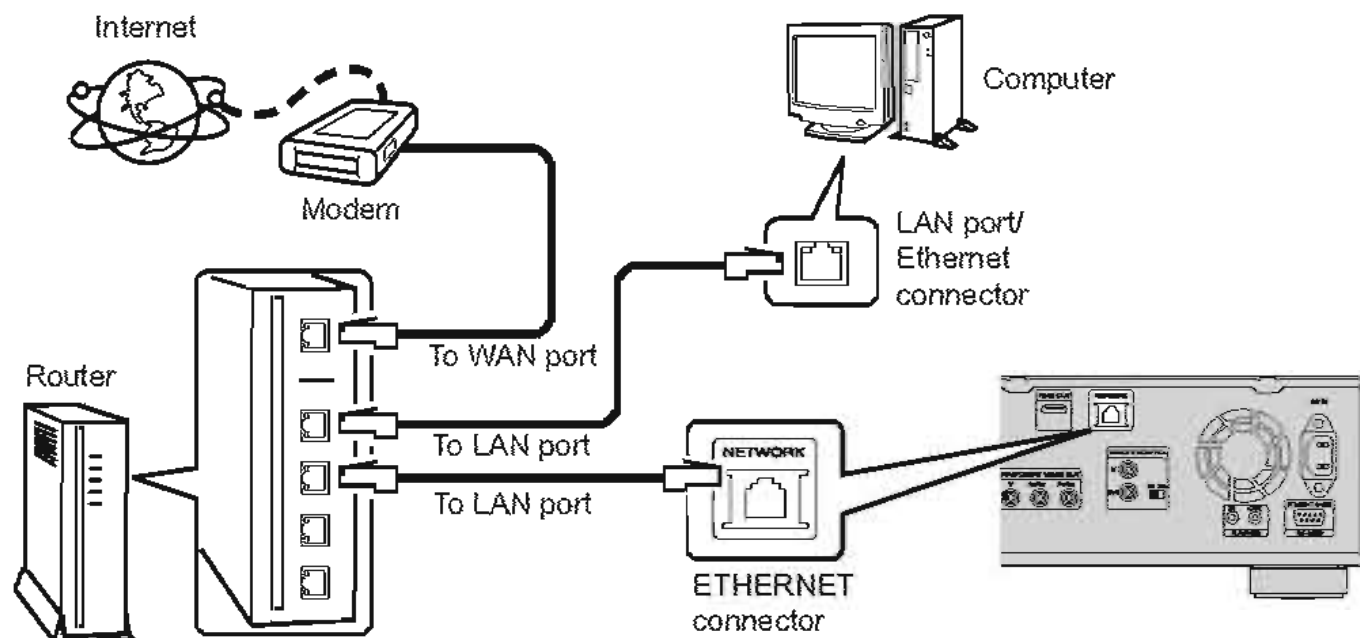

### 1.2. Check for Update and Update

Check if the latest firmware exists. You can also check approximately how long it will take to complete an update.

- (1) Press the SETUP button on the remote control to display the GUI menu.
- (2) Use the cursor buttons to select "Other settings" → "Firmware update" → "Update check".
- (3) Press the ENTER button.
  - The latest version of the firmware uploaded to the web is displayed.
  - If the latest firmware version is on the web, proceed to (4).
  - If the latest firmware is already installed, press the SETUP button to close the menu.
- (4) Use the cursor buttons to select "Update", then press the ENTER button.
  - During update, the power indicator lights red and the GUI screen is shut down. And a rough remaining time is indicated on the display.
  - When updating is complete the power indicator lights green and normal status is resumed.
- (5) Press the SETUP button to close the menu.

#### --- Cautions on Firmware Update ---

- In order to use these functions, you must have the correct system requirements and settings for a broadband Internet connection.
- Do not turn off the power until updating is completed.

Even with a broadband connection to the Internet, approximately about 1 hour is required for the updating procedure to be completed.

Once updating starts, normal operations on the UD8004 cannot be performed until updating is completed. Also, setting items of the GUI menu of DVD-A1UD or setting items of the image adjustment may be initialized.

Make a note of the settings before updating, and set them again after updating.

# TROUBLE SHOOTING

## 1. 8U-210095-7 (AUDIO UNIT)/ 8U-210094-2 (AUDIO2 UNIT)/ 8U-210094-3 (AUDIO3 UNIT)

Check connection B/E PWB UNIT  
8U-310041(B/E UNIT)  
•[CX331] input signal.  
•[CX332] input signal.

→ N.G. →

Check Soldering, FFC cable  
•[CX331]:8U-310041  
•[CX332]:8U-310041  
•Check FFC cable insertion

↓ O.K. ↓

Check DATA Signal  
8U-210095-7(AUDIO UNIT)  
•[IC301](DAC for 2ch(Mix) L/R)  
1,2,4,6,7pin(WCK=16/8/4fs,  
BCK=512/256/128fs,  
DATA,MCK=512/256/128fs)  
  
8U-210094-2(AUDIO2 UNIT)  
•[IC601](DAC for FL/FR)  
•[IC701](DAC for C/SW)  
1,2,4,6,7pin(WCK=16/8/4fs,  
BCK=512/256/128fs,  
DATA,MCK=512/256/128fs)  
  
8U-210094-3(AUDIO3 UNIT)  
•[IC801](DAC for SL/SR)  
•[IC901](DAC for SBR/SBL)  
1,2,4,6,7pin(WCK=16/8/4fs,  
BCK=512/256/128fs,  
DATA,MCK=512/256/128fs)

→ N.G. →

Check Soldering, FFC cable  
•[CY331][CX211]:8U-210095-7  
•[CY211][CY178]:8U-210094-2  
•[CY332][CX178]:8U-210094-3  
•Check FFC cable insertion

↓ O.K. ↓

Check DAC output  
8U-210095-7(AUDIO UNIT)  
•[IC301]:output  
  
8U-210094-2(AUDIO2 UNIT)  
•[IC601][IC701]:output  
  
8U-210094-3(AUDIO3 UNIT)  
•[IC801][IC901]:output

→ N.G. →

Check Soldering  
•[IC301][IC601][IC701]  
10,11,12pin(control line)  
•[IC801][IC901]  
10,11,12pin(control line)  
  
Check Power Supply Voltage  
•[CX061][CX062]:8U-210095-7  
1pin:about+11V/ 3pin:about-11V,  
5pin:about+5V/ 6pin:about+3.3V  
•[CY062]:8U-210094-2  
1pin:about+11V/ 3pin:about-9V,  
5pin:about+5V/ 6pin:about+3.3V  
•[CY061]:8U-210094-3  
1pin:about+11V/ 3pin:about-9V,  
5pin:about+5V/ 6pin:about+3.3V  
  
•Check cable insertion, and soldering  
  
•Check Fuse  
F301-F304

↓ O.K. ↓

Check AMP•OP AMP output  
 8U-210095-7(AUDIO UNIT)  
 •[IC302][IC306][IC303][IC307]  
 •Connections of [R415] and [R417]  
 •Connections of [R364] and [R366]

8U-210094-2(AUDIO2 UNIT)  
 •[IC605][IC604][IC606]  
 •Connections of [R679] and [R681]  
 •Connections of [R680] and [R682]  
 •[IC602][IC603][IC607]  
 •Connections of [R783] and [R785]  
 •Connections of [R778] and [R780]

8U-210094-3(AUDIO3 UNIT)  
 •[IC802][IC803][IC804]  
 •Connections of [R891] and [R893]  
 •Connections of [R892] and [R894]  
 •[IC902][IC903][IC904]  
 •Connections of [R967] and [R969]  
 •Connections of [R966] and [R968]

→ N.G. →

Check Soldering  
 •[IC302][IC306][IC303][IC307]  
 •[IC605][IC604][IC606]  
 •[IC602][IC603][IC607]  
 •[IC802][IC803][IC804]  
 •[IC902][IC903][IC904]

POWER C,R, TR

↓ O.K.

Check OUTPUT terminal  
 8U-210095-7(AUDIO UNIT)  
 •Check output signal from OUTPUT terminal  
 (Each channels)

8U-210094-2(AUDIO2 UNIT)  
 •Check output signal from OUTPUT terminal  
 (Each channels)

8U-210094-3(AUDIO3 UNIT)  
 •Check output signal from OUTPUT terminal  
 (Each channels)

→ N.G. →

Check Soldering  
 MUTE circuit:MUTE TR  
 8U-210095-7(AUDIO UNIT)  
 •TR325~TR328

8U-210094-2(AUDIO2 UNIT)  
 •TR628~TR631  
 •TR730,TR732,TR733,TR735,

8U-210094-3(AUDIO3 UNIT)  
 •TR829~TR832,TR925~TR928

TR-BASE terminal:about-12V(at MUTE off)  
 •Check Soldering, Output terminal

↓ O.K.

END

## 2. 8U-210094-1 (POWER UNIT)

### 2.1. The power cannot be turned on.

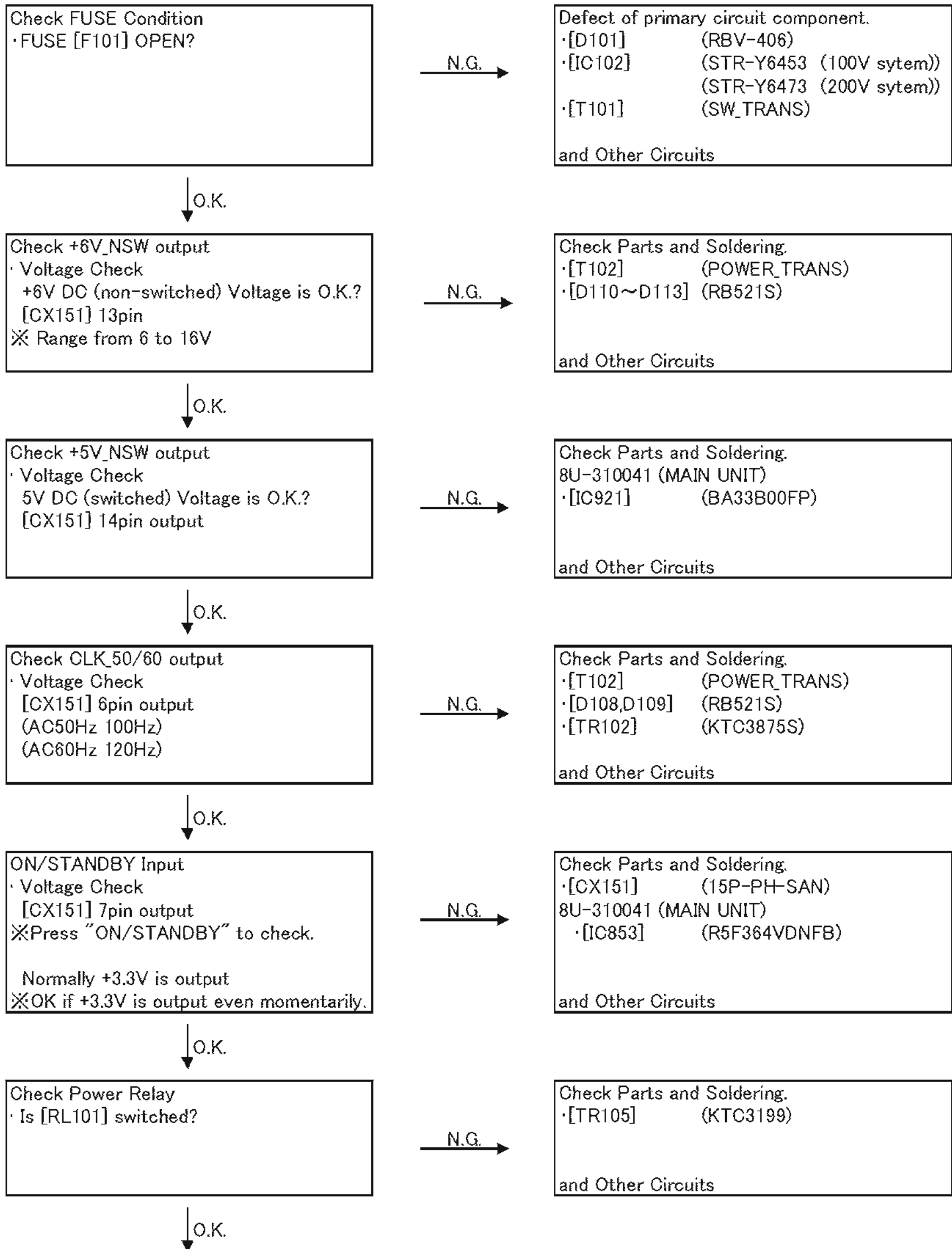



Check +5V output  
· Voltage Check  
+5V DC (switched) Voltage is O.K.?  
[L103] IC105 other side output

→ N.G. →

Check Parts and Soldering.  
· [IC105] (SI-8005Q-TL)  
and Other Circuits

↓ O.K. ↓

Is the rear side fan turning?

→ N.G. →

Check Parts and Soldering.  
· [TR304] (2SD1858)  
· [ZD302] (MTZJ9.1B)  
8U-310041 (MAIN UNIT)  
· [IC853] (R5F364VDNFB)  
and Other Circuits

↓ O.K. ↓

END

### 3. 8U-210095-4 (FRONT UNIT)

#### 3.1. FL TUBE dosen't light

Check  $\pm$  F output (5V)  
· [CY042] 3-4pin

↓ O.K.

Check -32V output  
· Voltage Check  
-32V DC (non-switched) Voltage is O.K.?  
[CY042] 2pin output

↓ O.K.

Check +3.3V output  
· Voltage Check  
3.3V DC (switched) Voltage is O.K.?  
[CY241] 18pin output

↓ O.K.

Check Parts and Soldering.  
· [IC101] (PT6302-SSOP)  
· [FL101]  
  
8U-210095-4 (FRONT UNIT)  
· [CY241] (24P-FMN)  
· FFC cable  
  
· [CY241] (24P FMN)  
(FL-TUBE(15-BT-114GNK))  
  
8U-310041 (MAIN UNIT)  
· [IC853] (R5F364VDNFB)  
  
and Other Circuits

↓ O.K.

END

→ N.G. →

Check Parts and Soldering.  
· [FL101]  
(FL-TUBE(15-BT-114GNK))  
  
8U-210094-1 (POWER UNIT)  
· [T101] (SW\_TRANS)  
· [D104] (AL01Z)  
· [ZD105] (MTZJ3.6B)  
  
and Other Circuits

→ N.G. →

Check Parts and Soldering.  
· [IC101] (PT6302-SSOP)  
  
8U-210094-1 (POWER UNIT)  
· [T101] (SW\_TRANS)  
· [TR103] (2SB562)  
· [ZD104, ZD107] (MTZJ16B)  
· [D106] (AL01Z)  
  
and Other Circuits

→ N.G. →

Check Parts and Soldering.  
· [IC101] (PT6302-SSOP)  
· [CY241] (24P-FMN)  
· FFC cable  
  
and Other Circuits

## 4. 8U-310041 (MAIN UNIT)

### 4.1. No System Power up or Loading

#### No Video or Audio Output

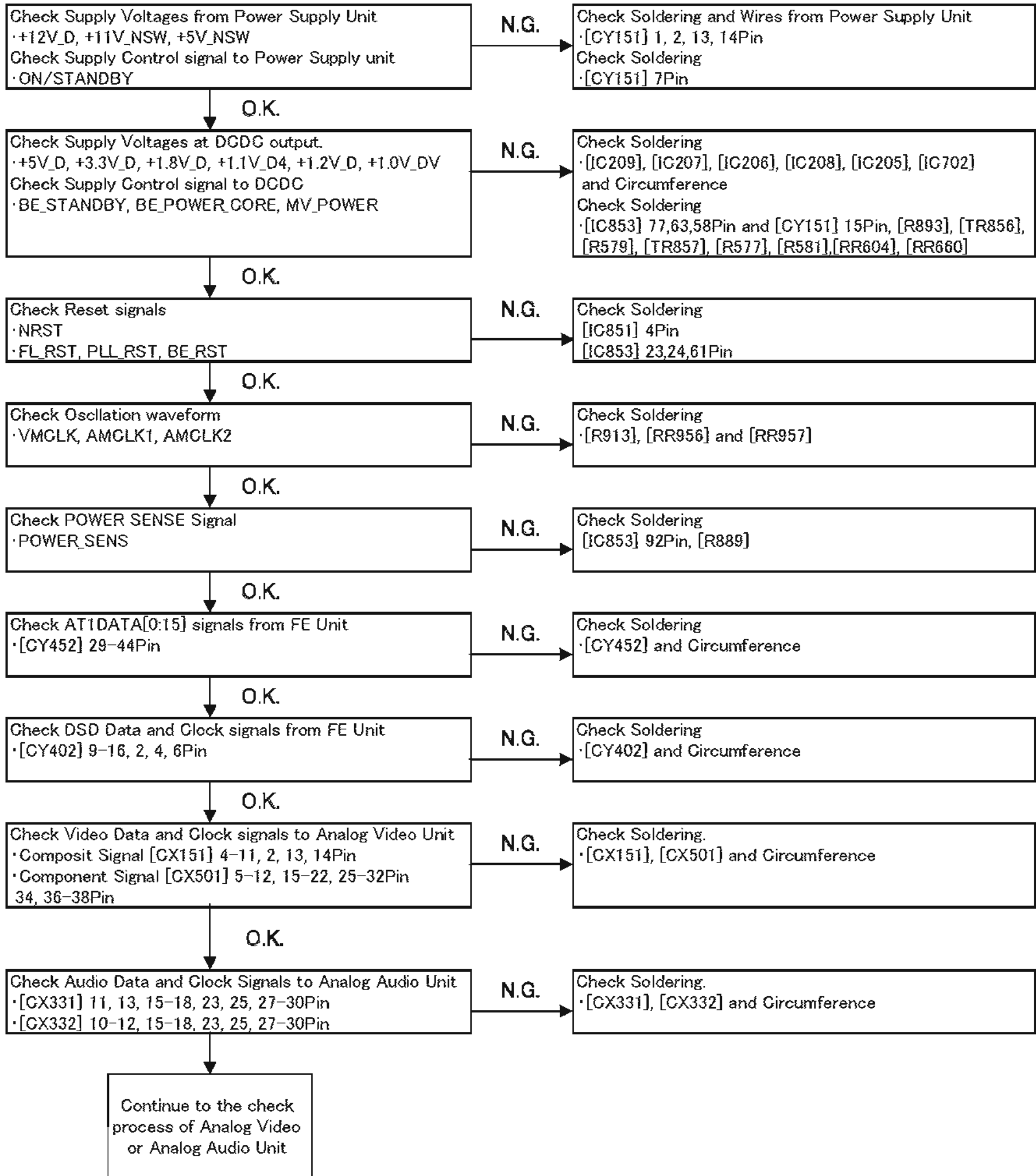

#### 4.2. No Ether-net Operation

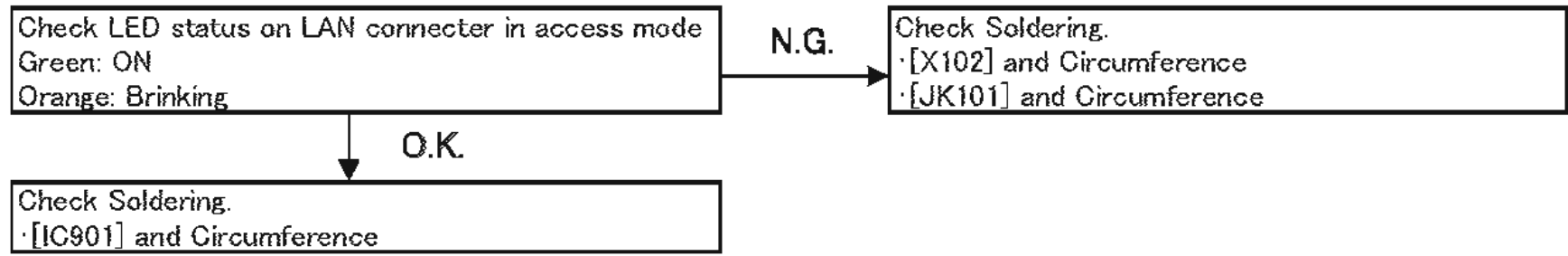

#### 4.3. No SD Card Operation

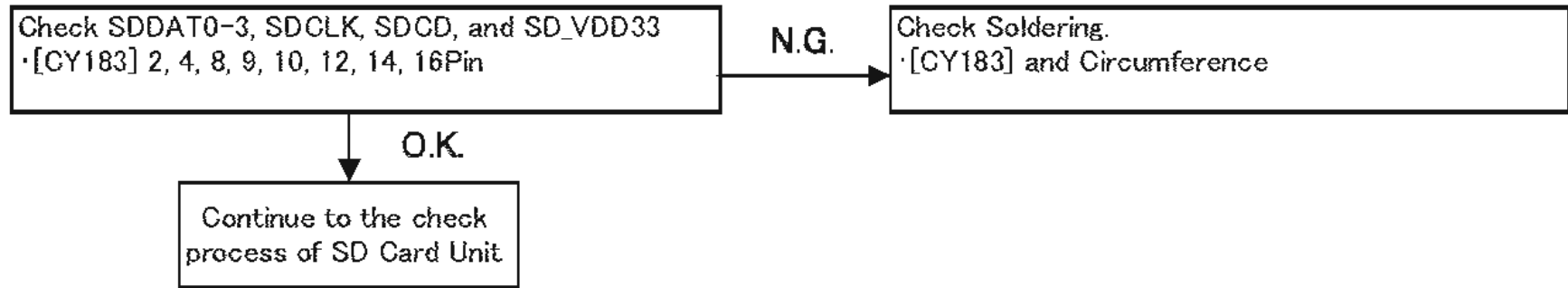

## 5. 8U-210095-1 (ANALOG VIDEO UNIT)

### 5.1. Video/S-Video Out does not be outputted.

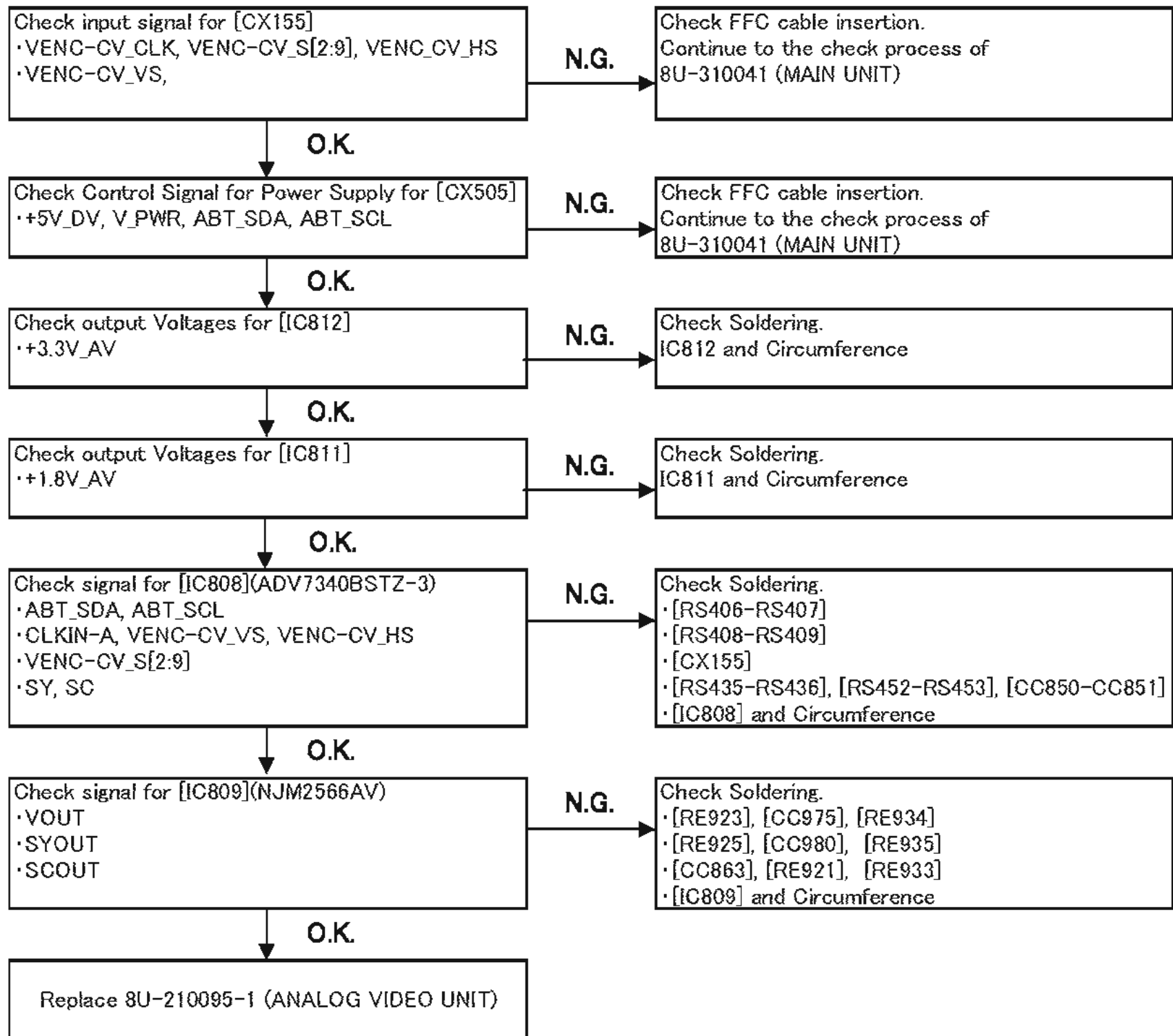

## 5.2. Component Out does not be outputted

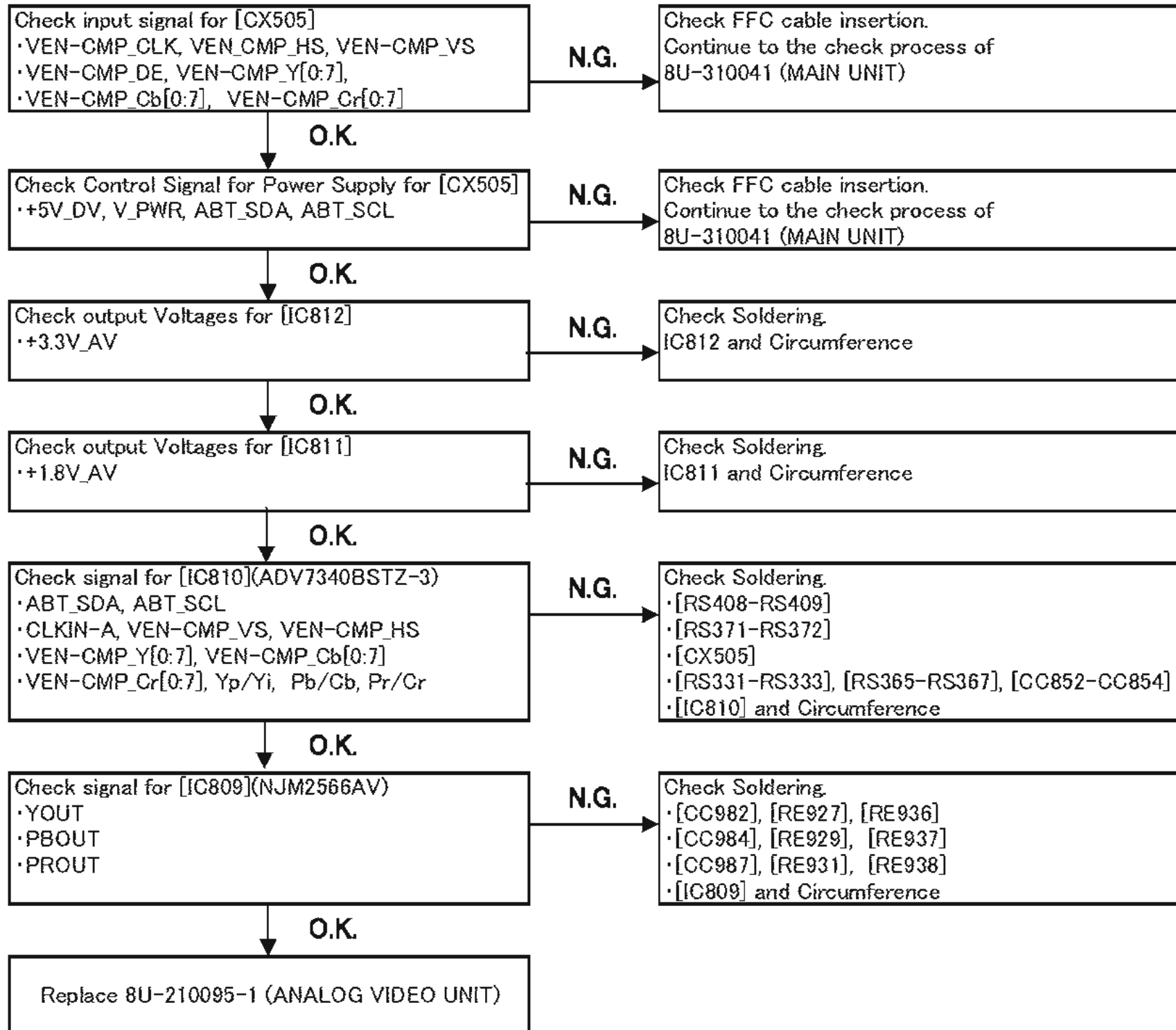

## 6. 8U-310037 (FE/SACD UNIT)

### 6.1. BD or DVD or CD or SACD check

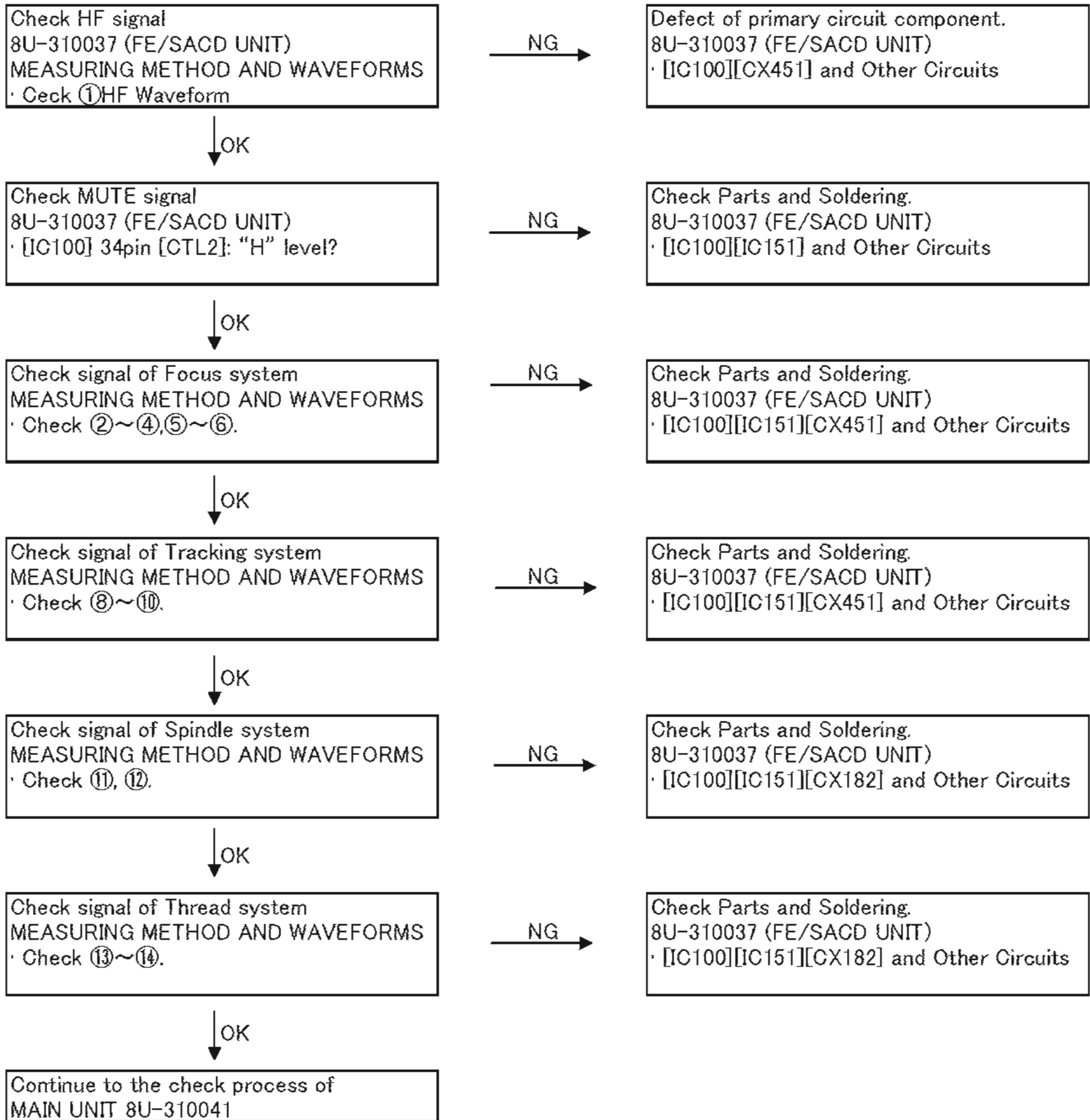

# SEMICONDUCTORS

Only major semiconductors are shown, general semiconductors etc. are omitted to list.  
 The semiconductor which described a detailed drawing in a schematic diagram are omitted to list.

## 1. IC's

### SII9134CTU (8U-310041 : IC502)

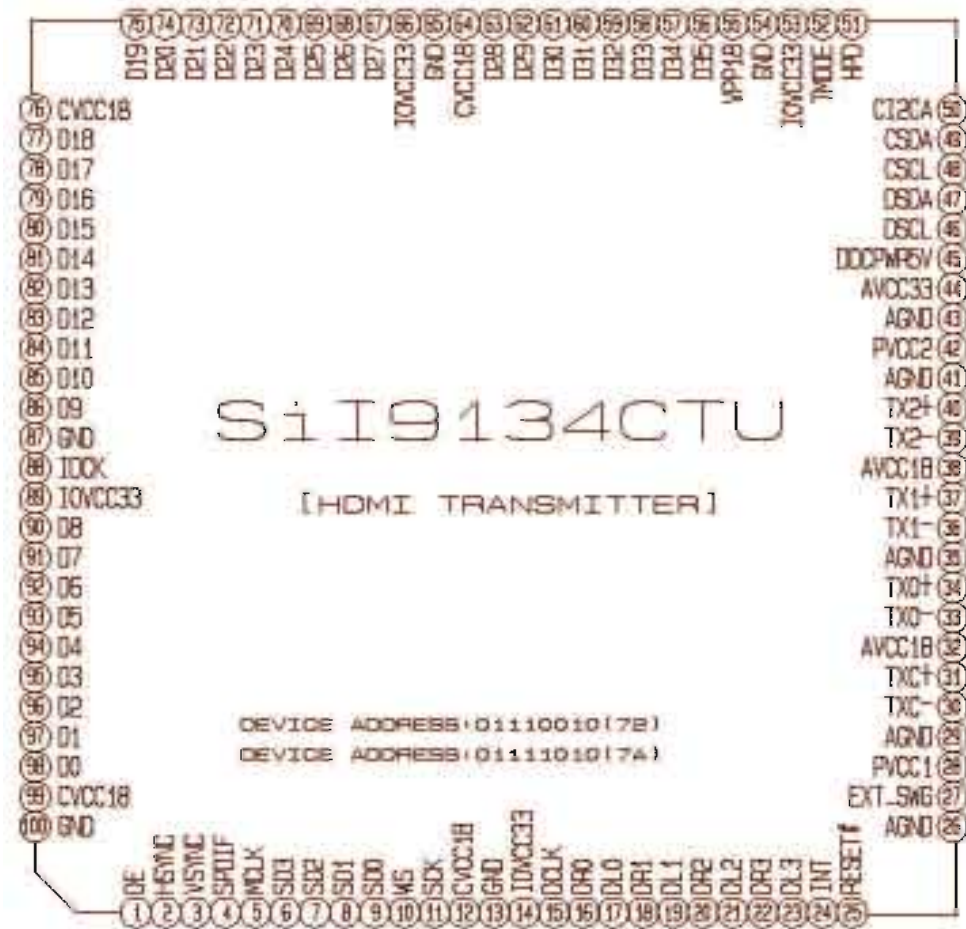

### SII9134CTU Block Diagram

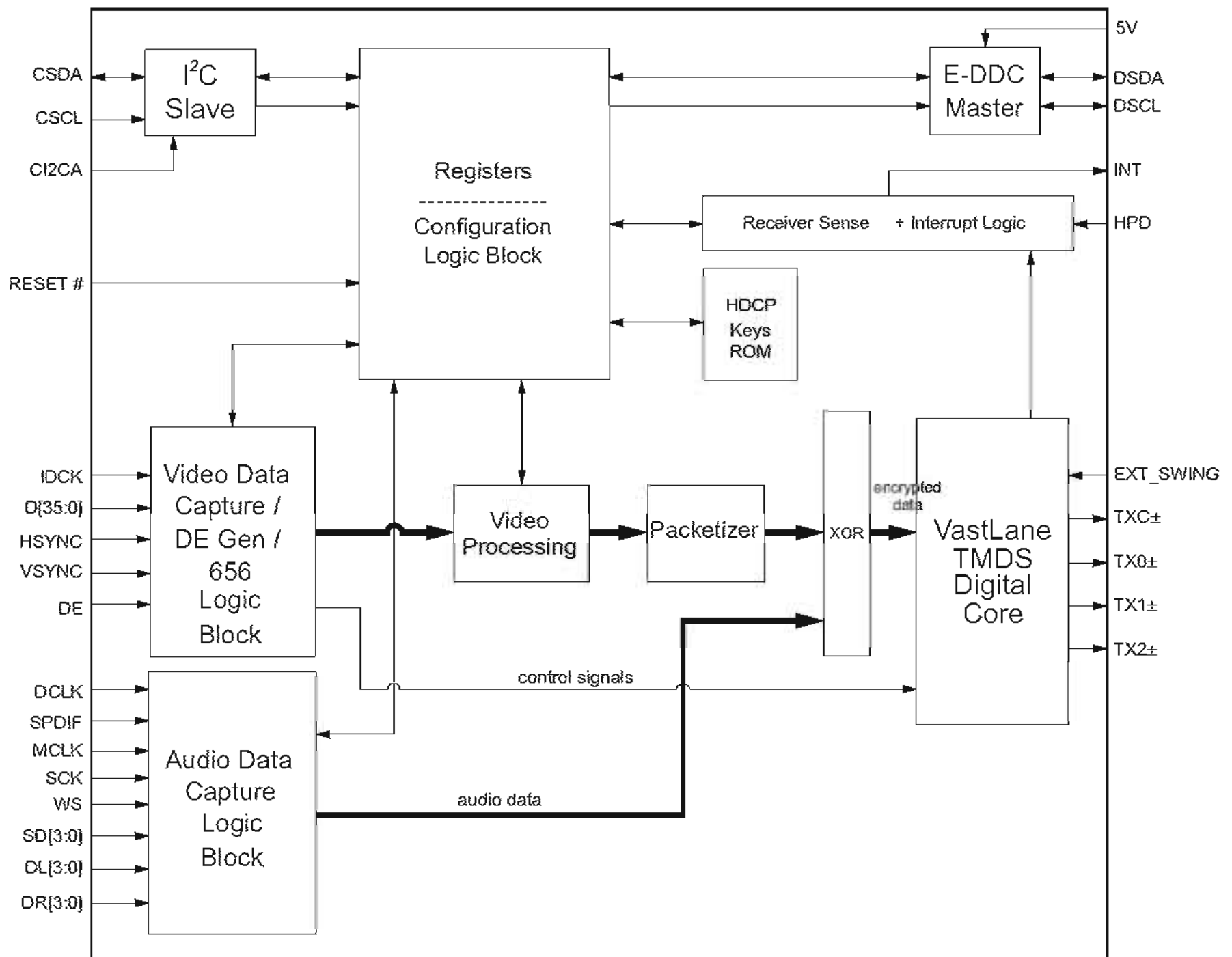



## SI9134CTU Pin Function

Pin Name	Pin #	Type	Dir	Description
D0	98	LVTTL	Input	These are the lower 12 bits of the 36-bit pixel bus. These pins are highly configurable and support multiple RGB and YCbCr formats. See Data Bus Mappings on page 30 for complete information.
D1	97	LVTTL	Input	
D2	96	LVTTL	Input	
D3	95	LVTTL	Input	
D4	94	LVTTL	Input	
D5	93	LVTTL	Input	
D6	92	LVTTL	Input	
D7	91	LVTTL	Input	
D8	90	LVTTL	Input	
D9	86	LVTTL	Input	
D10	85	LVTTL	Input	
D11	84	LVTTL	Input	
D12	83	LVTTL	Input	These are the middle 12 bits of the 36-bit pixel bus.
D13	82	LVTTL	input	
D14	81	LVTTL	Input	
D15	80	LVTTL	input	
D16	79	LVTTL	Input	
D17	78	LVTTL	Input	
D18	77	LVTTL	Input	
D19	75	LVTTL	Input	
D20	74	LVTTL	Input	
D21	73	LVTTL	input	
D22	72	LVTTL	Input	
D23	71	LVTTL	input	
D24	70	LVTTL	Input	
D25	69	LVTTL	input	
D26	68	LVTTL	Input	
D27	67	LVTTL	Input	
D28	63	LVTTL	input	
D29	62	LVTTL	Input	
D30	61	LVTTL	Input	
D31	60	LVTTL	Input	
D32	59	LVTTL	input	
D33	58	LVTTL	Input	
D34	57	LVTTL	input	
D35	56	LVTTL	Input	
IDCK	88	LVTTL	Input	Input Data Clock
DE	1	LVTTL	Input	Data enable
HSYNC	2	LVTTL	Input	Horizontal Sync input control signal
VSYNC	3	LVTTL	Input	Vertical Sync input control signal
SCK	11	LVTTL	Input	I2S Serial Clock
WS	10	LVTTL	Input	I2S Word Select
SD0	9	LVTTL	Input	I2S Serial Data
SD1	8	LVTTL	Input	I2S Serial Data
SD2	7	LVTTL	input	I2S Serial Data
SD3	6	LVTTL	Input	I2S Serial Data
DL0	17	LVTTL	Input	One-bit Audio Data Left 0
DR0	16	LVTTL	Input	One-bit Audio Data Right 0
DL1	19	LVTTL	Input	One-bit Audio Data Left 1
DR1	18	LVTTL	input	One-bit Audio Data Right 1
DL2	21	LVTTL	Input	One-bit Audio Data Left 2
DR2	20	LVTTL	input	One-bit Audio Data Right 2
DL3	23	LVTTL	Input	One-bit Audio Data Left 3
DR3	22	LVTTL	input	One-bit Audio Data Right 3
DCLK	15	LVTTL	Input	One-bit Audio Clock Input
MCLK	5	LVTTL	Input	Audio Input Master Clock
SPDIF	4	LVTTL	Input	S/PDIF Audio Input

# R5F364VDNFB (8U-310041 : IC853)

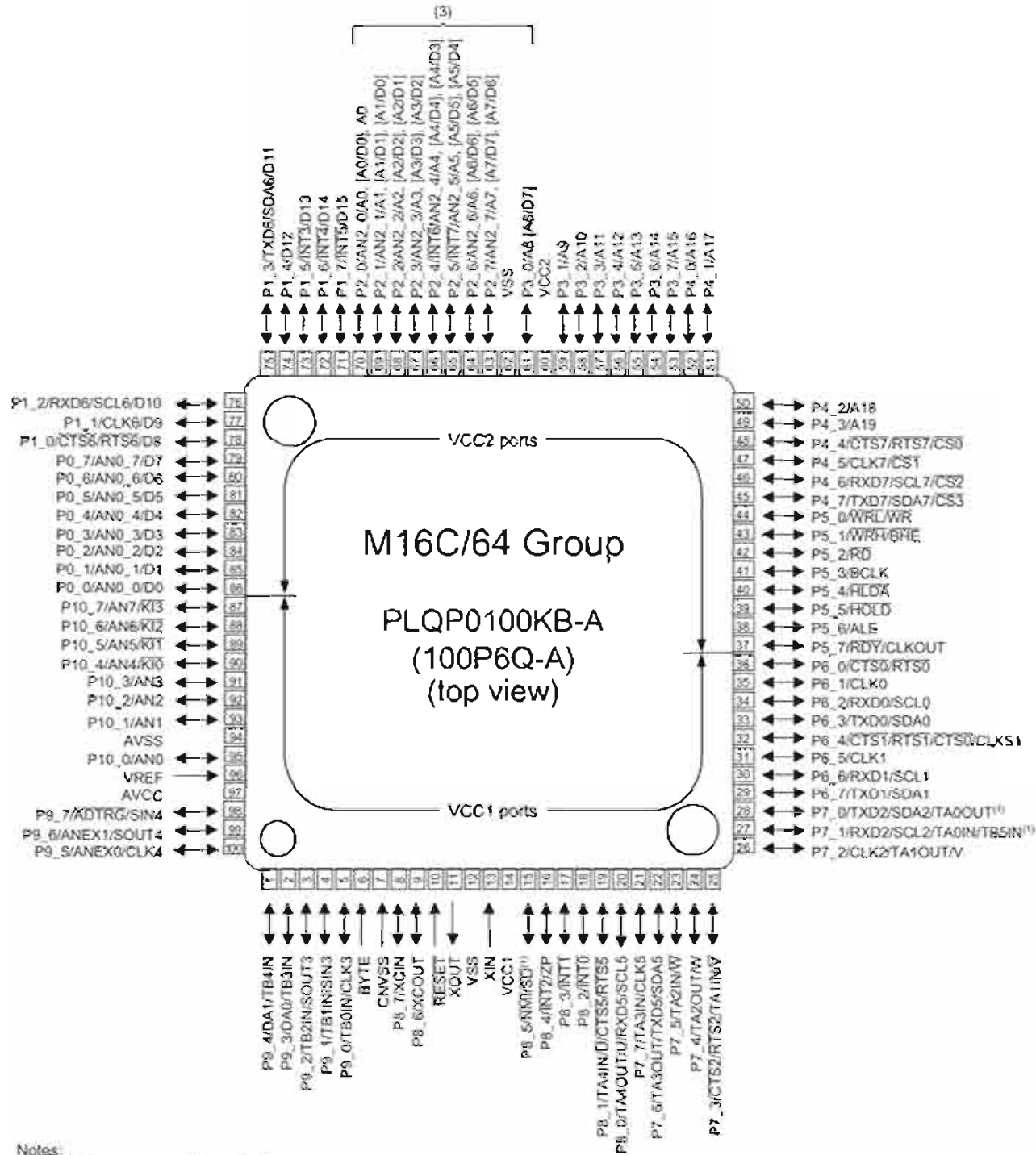

- Notes:
1. N-channel open-drain output.
  2. Check the position of Pin 1 by referring to appendix 1, Package Dimensions.
  3. Symbols in brackets [ ] represent a functional signal as a whole.

## R5F364VDNFB Block Diagram

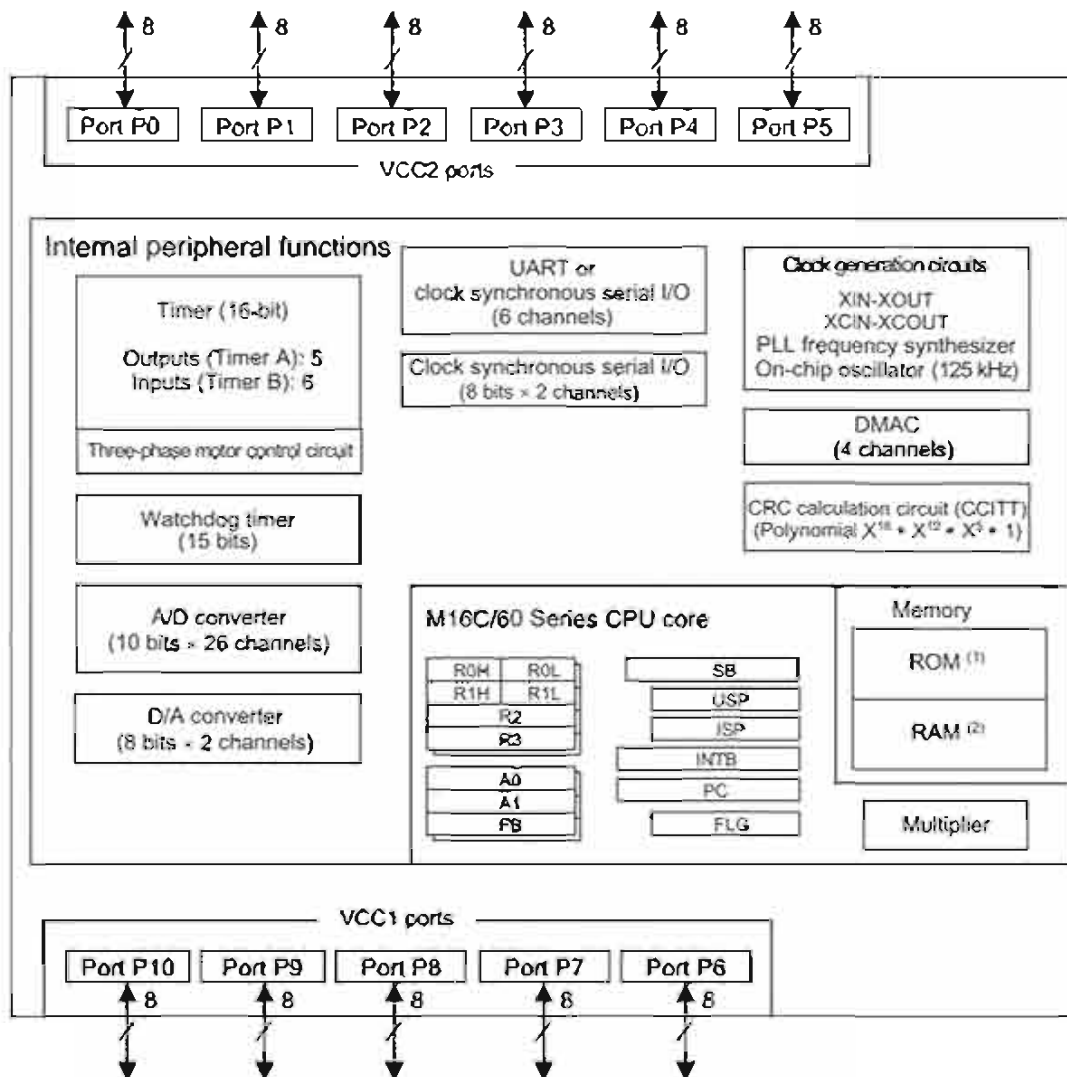

- Notes :
1. ROM size depends on MCU type.
  2. RAM size depends on MCU type.

R5F364VDNFB Pin Function

Pin No.		Control Pin	Port	I/O Pin Functions for of Peripheral Modules				Bus Control Pin
FA	FB			Interrupt	Timer	Serial interface	A/D converter D/A converter	
1	99		P9_6			SOUT4	ANEX1	
2	100		P9_5			CLK4	ANEX0	
3	1		P9_4		TB4IN		DA1	
4	2		P9_3		TB3IN		DA0	
5	3		P9_2		TB2IN	SOUT3		
6	4		P9_1		TB1IN	SIN3		
7	5		P9_0		TB0IN	CLK3		
8	6	BYTE						
9	7	CNVSS						
10	8	XCIN	P8_7					
11	9	XCOU	P8_6					
12	10	RESET						
13	11	XOUT						
14	12	VSS						
15	13	XIN						
16	14	VCC1						
17	15		P8_5	NMI	SD			
18	16		P8_4	INT2	ZP			
19	17		P8_3	INT1				
20	18		P8_2	INT0				
21	19		P8_1		TA4IN/U	CTS5/RTS5		
22	20		P8_0		TA4OUT/U	RXD5/SCL5		
23	21		P7_7		TA3IN	CLK5		
24	22		P7_6		TA3OUT	TXD5/SDA5		
25	23		P7_5		TA2IN/W			
26	24		P7_4		TA2OUT/W			
27	25		P7_3		TA1IN/V	CTS2/RTS2		
28	26		P7_2		TA1OUT/V	CLK2		
29	27		P7_1		TA0IN/TB5IN	RXD2/SCL2		
30	28		P7_0		TA0OUT	TXD2/SDA2		
31	29		P6_7			TXD1/SDA1		
32	30		P6_6			RXD1/SCL1		
33	31		P6_5			CLK1		
34	32		P6_4			CTS1/RTS1/CTS0/CLKS1		
35	33		P6_3			TXD0/SDA0		
36	34		P6_2			RXD0/SCL0		
37	35		P6_1			CLK0		
38	36		P6_0			CTS0/RTS0		
39	37		P5_7					RDY/CLKOUT
40	38		P5_6					ALE
41	39		P5_5					HOLD
42	40		P5_4					HLDA
43	41		P5_3					BCLK
44	42		P5_2					RD
45	43		P5_1					WRH/BHE
46	44		P5_0					WRL/WR
47	45		P4_7			TXD7/SDA7		CS3
48	46		P4_6			RXD7/SCL7		CS2
49	47		P4_5			CLK7		CS1
50	48		P4_4			CTS7/RTS7		CS0

Pin No.		Control Pin	Port	I/O Pin Functions for of Peripheral Modules				Bus Control Pin
FA	FB			Interrupt	Timer	Serial interface	A/D converter D/A converter	
51	49		P4_3					A19
52	50		P4_2					A18
53	51		P4_1					A17
54	52		P4_0					A16
55	53		P3_7					A15
56	54		P3_6					A14
57	55		P3_5					A13
58	56		P3_4					A12
59	57		P3_3					A11
60	58		P3_2					A10
61	59		P3_1					A9
62	60	VCC2						
63	61		P3_0					A8, [A8/D7]
64	62	VSS						
65	63		P2_7				AN2_7	A7, [A7/D7], [A7/D6]
66	64		P2_6				AN2_6	A6, [A6/D6], [A6/D5]
67	65		P2_5	$\overline{\text{INT7}}$			AN2_5	A5, [A5/D5], [A5/D4]
68	66		P2_4	$\overline{\text{INT6}}$			AN2_4	A4, [A4/D4], [A4/D3]
69	67		P2_3				AN2_3	A3, [A3/D3], [A3/D2]
70	68		P2_2				AN2_2	A2, [A2/D2], [A2/D1]
71	69		P2_1				AN2_1	A1, [A1/D1], [A1/D0]
72	70		P2_0				AN2_0	A0, [A0/D0], A0
73	71		P1_7	$\overline{\text{INT5}}$				D15
74	72		P1_6	$\overline{\text{INT4}}$				D14
75	73		P1_5	$\overline{\text{INT3}}$				D13
76	74		P1_4					D12
77	75		P1_3			TXD6/SDA6		D11
78	76		P1_2			RXD6/SCL6		D10
79	77		P1_1			CLK6		D9
80	78		P1_0			$\overline{\text{CTS6/RTS6}}$		D8
81	79		P0_7				AN0_7	D7
82	80		P0_6				AN0_6	D6
83	81		P0_5				AN0_5	D5
84	82		P0_4				AN0_4	D4
85	83		P0_3				AN0_3	D3
86	84		P0_2				AN0_2	D2
87	85		P0_1				AN0_1	D1
88	86		P0_0				AN0_0	D0
89	87		P10_7	$\overline{\text{KI3}}$			AN7	
90	88		P10_6	$\overline{\text{KI2}}$			AN6	
91	89		P10_5	$\overline{\text{KI1}}$			AN5	
92	90		P10_4	$\overline{\text{KI0}}$			AN4	
93	91		P10_3				AN3	
94	92		P10_2				AN2	
95	93		P10_1				AN1	
96	94	AVSS						
97	95		P10_0				AN0	
98	96	VREF						
99	97	AVCC						
100	98		P9_7			SIN4	$\overline{\text{ADTRG}}$	

ADV7340BSTZ-3 (8U-210095-1 : IC808, IC810)

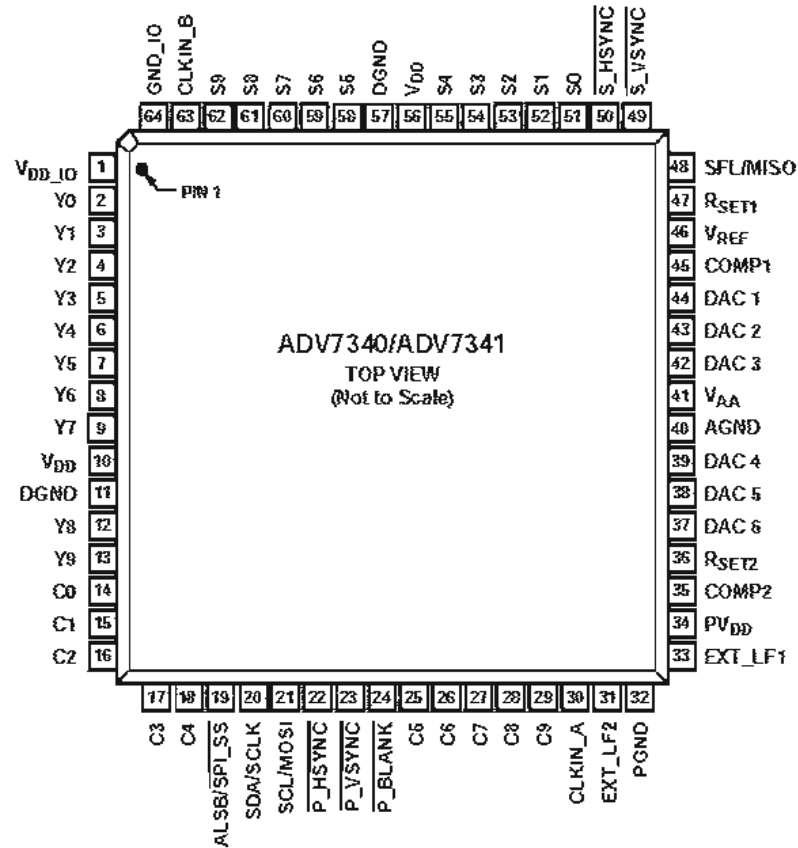

ADV7340BSTZ-3 Block Diagram

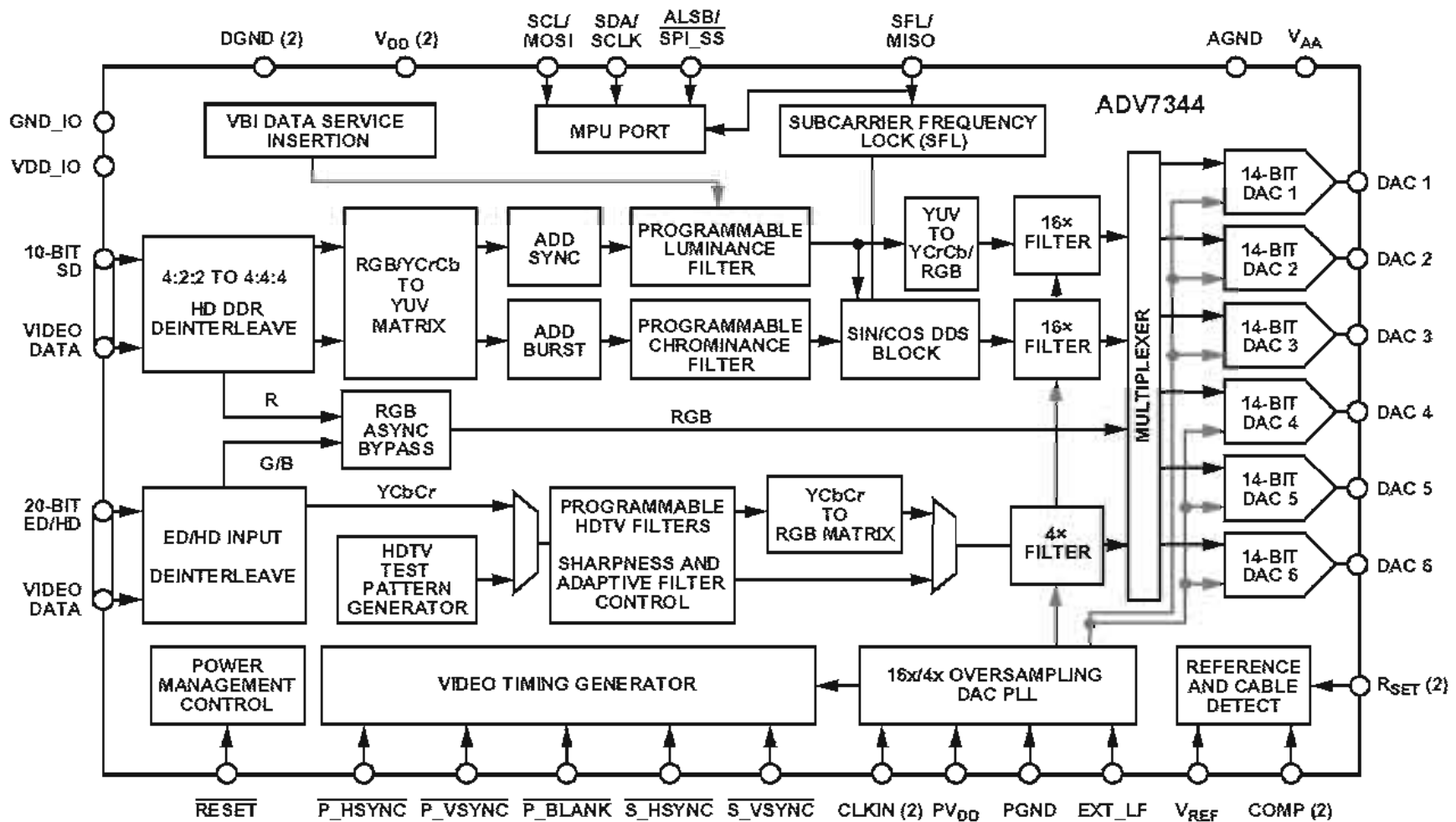

## ADV7340BSTZ-3 Pin Function

Pin No.	Mnemonic	Input/ Output	Description
13, 12, 9 to 2	Y9 to Y0	I	10-Bit Pixel Port (Y9 to Y0). Y0 is the LSB. Refer to Table 31 for input modes.
29 to 25, 18 to 14	C9 to C0	I	10-Bit Pixel Port (C9 to C0). C0 is the LSB. Refer to Table 31 for input modes.
62 to 58, 55 to 51	S9 to S0	I	10-Bit Pixel Port (S9 to S0). S0 is the LSB. Refer to Table 31 for input modes.
30	CLKIN_A	I	Pixel Clock Input for HD Only (74.25 MHz), ED <sup>1</sup> Only (27 MHz or 54 MHz), or SD Only (27 MHz).
63	CLKIN_B	I	Pixel Clock Input for Dual Modes Only. Requires a 27 MHz reference clock for ED operation or a 74.25 MHz reference clock for HD operation.
50	$\overline{S\_HSYNC}$	I/O	SD Horizontal Synchronization Signal. This pin can also be configured to output an SD, ED, or HD horizontal synchronization signal. See the External Horizontal and Vertical Synchronization Control section.
49	$\overline{S\_VSYNC}$	I/O	SD Vertical Synchronization Signal. This pin can also be configured to output an SD, ED, or HD vertical synchronization signal. See the External Horizontal and Vertical Synchronization Control section.
22	$\overline{P\_HSYNC}$	I	ED/HD Horizontal Synchronization Signal. See the External Horizontal and Vertical Synchronization Control section.
23	$\overline{P\_VSYNC}$	I	ED/HD Vertical Synchronization Signal. See the External Horizontal and Vertical Synchronization Control section.
24	$\overline{P\_BLANK}$	I	ED/HD Blanking Signal. See the External Horizontal and Vertical Synchronization Control section.
48	SFL/MISO	I/O	Multifunctional Pin: Subcarrier Frequency Lock (SFL) Input/SPI Data Output. The SFL input is used to drive the color subcarrier DDS system, timing reset, or subcarrier reset.
47	R <sub>SET1</sub>	I	This pin is used to control the amplitudes of the DAC 1, DAC 2, and DAC 3 outputs. For full-drive operation (for example, into a 37.5 $\Omega$ load), a 510 $\Omega$ resistor must be connected from R <sub>SET1</sub> to AGND. For low drive operation (for example, into a 300 $\Omega$ load), a 4.12 k $\Omega$ resistor must be connected from R <sub>SET1</sub> to AGND.
36	R <sub>SET2</sub>	I	This pin is used to control the amplitudes of the DAC 4, DAC 5, and DAC 6 outputs. A 4.12 k $\Omega$ resistor must be connected from R <sub>SET2</sub> to AGND.

Pin No.	Mnemonic	Input/ Output	Description
44, 43, 42	DAC 1, DAC 2, DAC 3	O	DAC Outputs. Full and low drive capable DACs.
39, 38, 37	DAC 4, DAC 5, DAC 6	O	DAC Outputs. Low drive only capable DACs.
21	SCL/MOSI	I	Multifunctional Pin: PC Clock Input/SPI Data Input.
20	SDA/SCLK	I/O	Multifunctional Pin: PC Data Input/Output. Also, SPI clock input.
19	$\overline{ALS\overline{B}/S\overline{PI\_SS}}$	I	Multifunctional Pin: This signal sets up the LSB <sup>2</sup> of the MPU PC address. Also, SPI slave select.
46	V <sub>REF</sub>		Optional External Voltage Reference Input for DACs or Voltage Reference Output.
41	V <sub>AA</sub>	P	Analog Power Supply (3.3 V).
10, 56	V <sub>DD</sub>	P	Digital Power Supply (1.8 V). For dual-supply configurations, V <sub>DD</sub> can be connected to other 1.8 V supplies through a ferrite bead or suitable filtering.
1	V <sub>DD_IO</sub>	P	Input/Output Digital Power Supply (3.3 V).
34	PV <sub>DD</sub>	P	PLL Power Supply (1.8 V). For dual-supply configurations, PV <sub>DD</sub> can be connected to other 1.8 V supplies through a ferrite bead or suitable filtering.
33	EXT_LF1	I	External Loop Filter for On-Chip PLL 1.
31	EXT_LF2	I	External Loop Filter for On-Chip PLL 2.
32	PGND	G	PLL Ground Pin.
40	AGND	G	Analog Ground Pin.
11, 57	DGND	G	Digital Ground Pin.
64	GND_IO	G	Input/Output Supply Ground Pin.

<sup>1</sup> ED = enhanced definition = 525p and 625p.

<sup>2</sup> LSB = least significant bit. In the ADV7344, setting the LSB to 0 sets the PC address to 0xD4. Setting it to 1 sets the PC address to 0xD6.

PT6302-R-001(L) (8U-210095-4 : IC101)

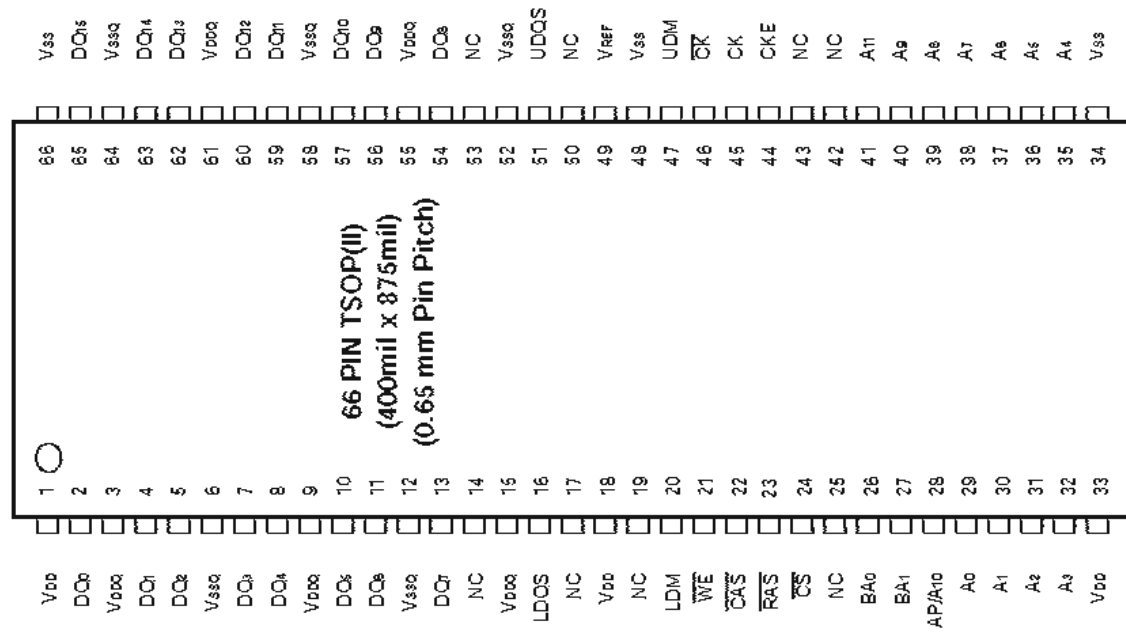

PT6302-R-001(L) Block Diagram

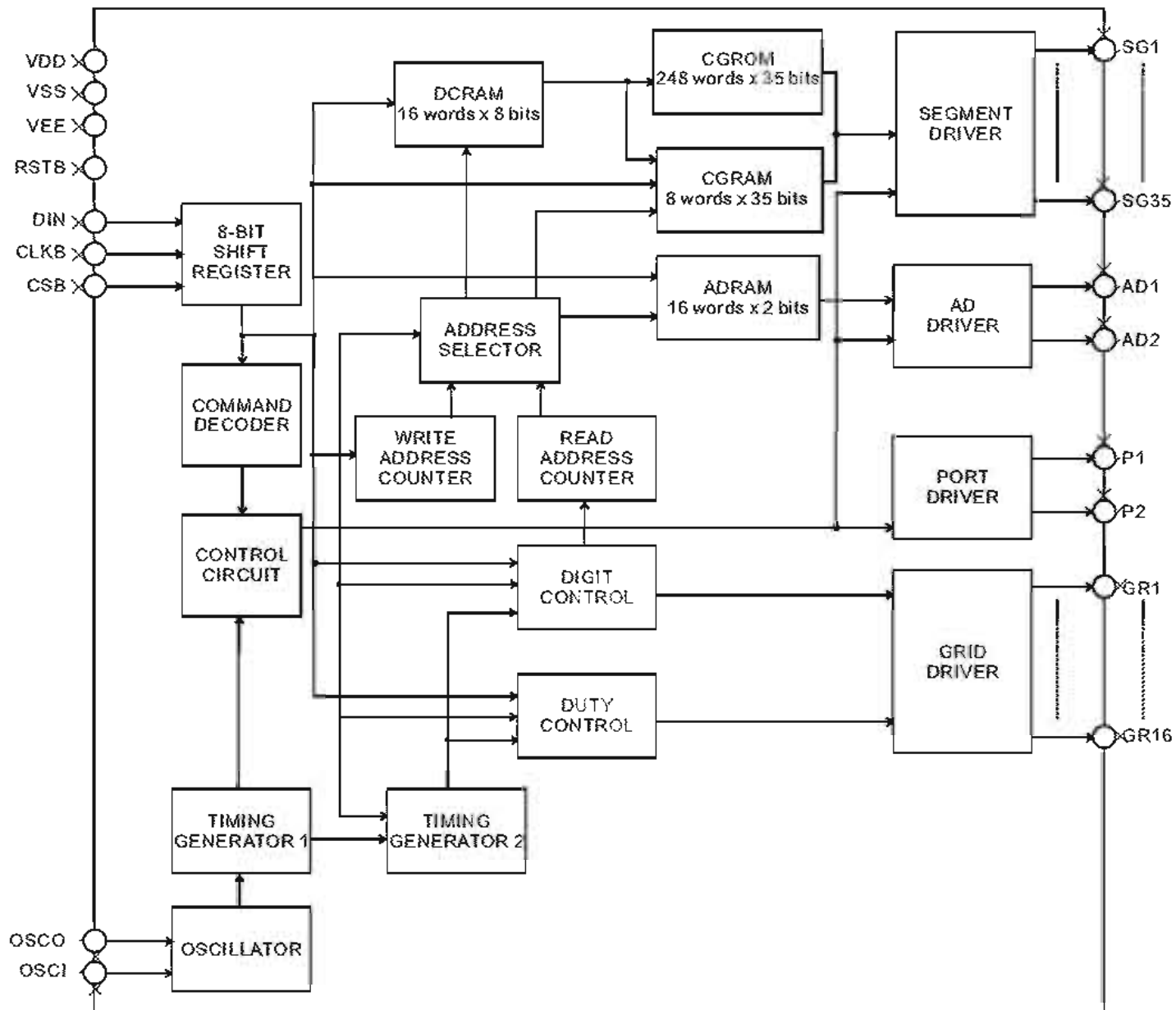

PT6302-R-001(L) Pin Function

Pin Name	I/O	Description	Pin No.	
			LQFP	SSOP
SG5 to SG35 SG4 to SG1	O	Segment driver output pin	1 ~ 31 64 ~ 61	9 ~ 39 8 ~ 5
GR1 to GR16	O	Grid driver output pin	32 ~ 47	40 ~ 55
VEE	-	Power supply	48	56
VSS	-	Ground pin	49	57
OSCI	I	Oscillator input pin	50	58
OSCO	O	Oscillator output pin	51	59
RSTB	I	Reset input pin When this pin is set to "LOW", all functions are initialized.	52	60
CSB	I	Chip select input pin When this pin is set to "High" Level, the serial data transfer is disabled.	53	61
CLKB	I	Shift clock input pin The serial data is shifted at the rising edge of CLKB.	54	62
DIN	I	Serial data input pin	55	63
VDD	-	Positive power supply	56	64
P1 to P2	O	General purpose output pin	57 ~ 58	1 ~ 2
AD2 to AD1	O	Segment driver output pin	59 ~ 60	3 ~ 4



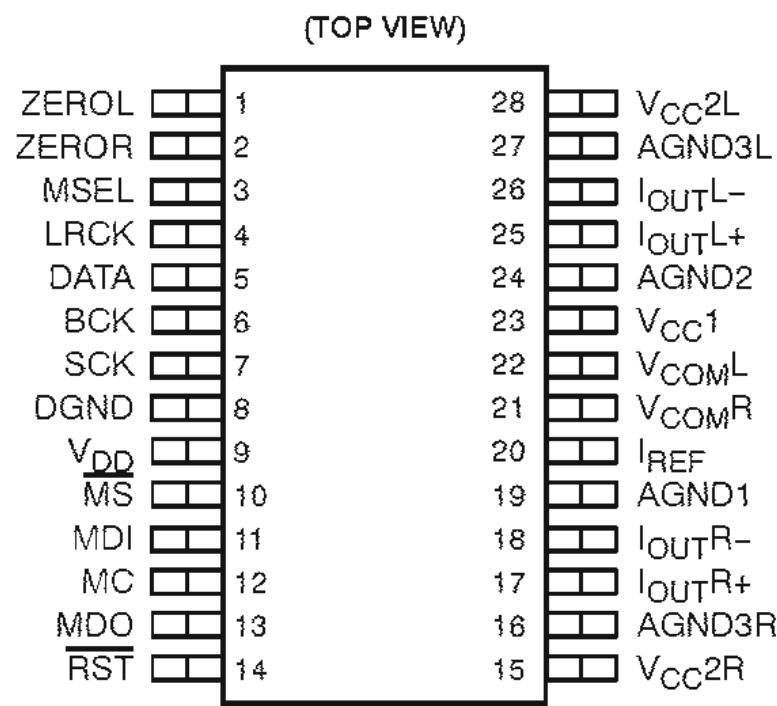

PCM1796DBR Block Diagram

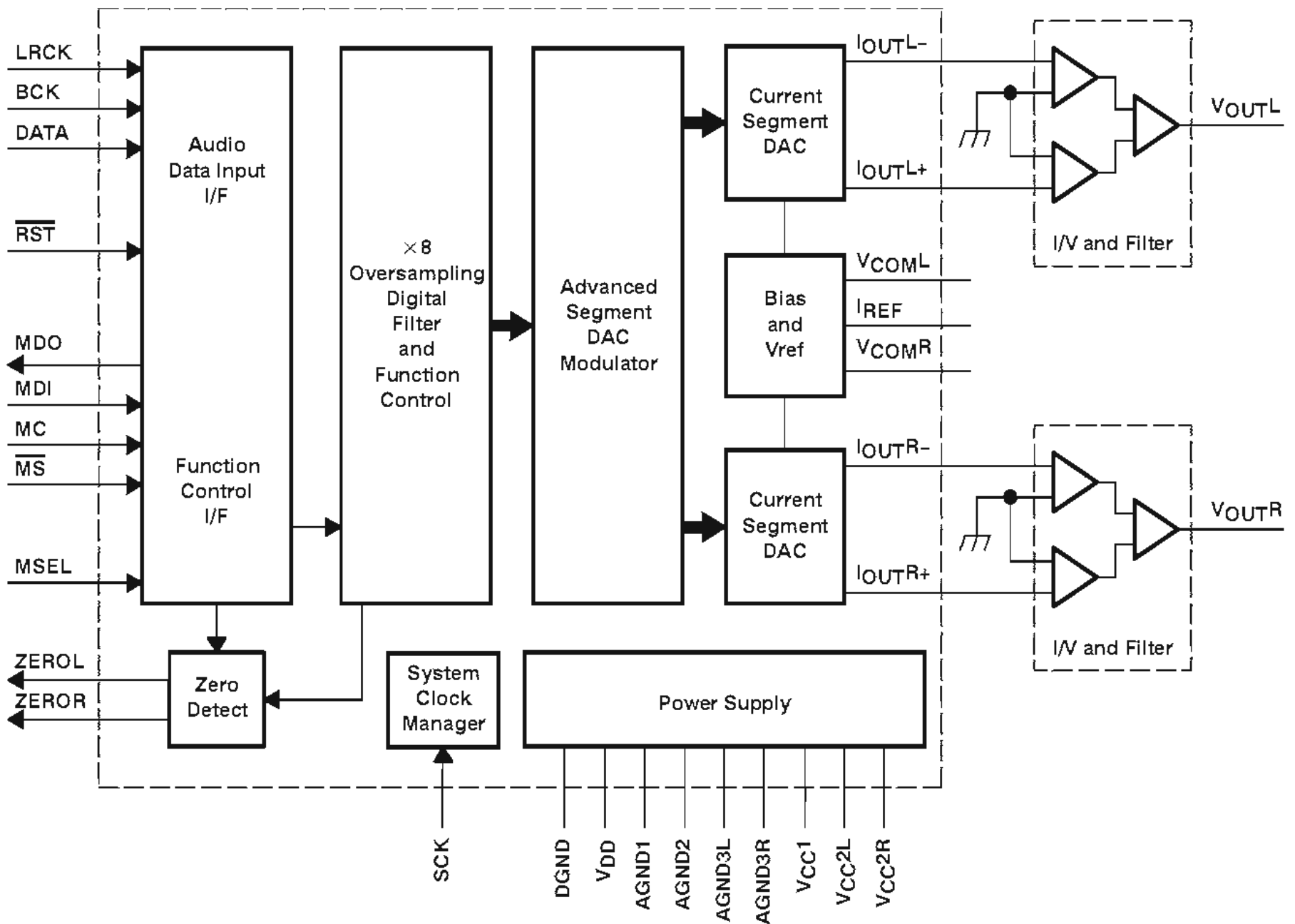

## PCM1796DBR Pin Function

TERMINAL NAME	PIN	I/O	DESCRIPTIONS
AGND1	19	–	Analog ground (internal bias)
AGND2	24	–	Analog ground (internal bias)
AGND3L	27	–	Analog ground (L-channel DACFF)
AGND3R	16	–	Analog ground (R-channel DACFF)
BCK	6	I	Bit clock input <sup>(1)</sup>
DATA	5	I	Serial audio data input <sup>(1)</sup>
DGND	8	–	Digital ground
IOUTL+	25	O	L-channel analog current output+
IOUTL–	26	O	L-channel analog current output–
IOUTR+	17	O	R-channel analog current output+
IOUTR–	18	O	R-channel analog current output–
IREF	20	–	Output current reference bias pin
LRCK	4	I	Left and right clock (f <sub>S</sub> ) input <sup>(1)</sup>
MC	12	I	Mode control clock input <sup>(1)</sup>
MDI	11	I	Mode control data input <sup>(1)</sup>
MDO	13	I/O	Mode control readback data output <sup>(3)</sup>
$\overline{MS}$	10	I/O	Mode control chip-select input <sup>(2)</sup>
MSEL	3	I	I <sup>2</sup> C/SPI select <sup>(1)</sup>
$\overline{RST}$	14	I	Reset <sup>(1)</sup>
SCK	7	I	System clock input <sup>(1)</sup>
VCC1	23	–	Analog power supply, 5 V
VCC2L	28	–	Analog power supply (L-channel DACFF), 5 V
VCC2R	15	–	Analog power supply (R-channel DACFF), 5 V
VCOML	22	–	L-channel internal bias decoupling pin
VCOMR	21	–	R-channel internal bias decoupling pin
VDD	9	–	Digital power supply, 3.3 V
ZEROL	1	I/O	Zero flag for L-channel <sup>(2)</sup>
ZEROR	2	I/O	Zero flag for R-channel <sup>(2)</sup>

(1) Schmitt-trigger input, 5-V tolerant

(2) Schmitt-trigger input and output. 5-V tolerant input and CMOS output

(3) Schmitt-trigger input and output. 5-V tolerant input. In I<sup>2</sup>C mode, this pin becomes an open-drain 3-state output; otherwise, this pin is a CMOS output.

PCA9539PW,188 (8U-310041 : IC601)

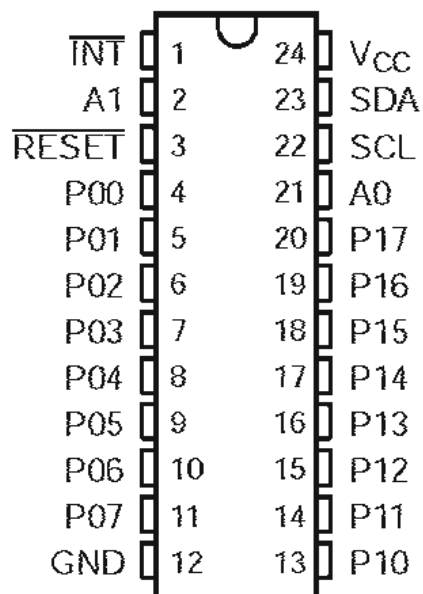

PCA9539PW,188 Pin Function

NO.		NAME	DESCRIPTION
SOIC (DWW), SSOP (DB), QSOP (DBQ), TSSOP (PW), AND TVSOP (DGV)	QFN (RGE)		
1	22	INT	Interrupt output. Connect to V <sub>CC</sub> through a pullup resistor.
2	23	A1	Address input. Connect directly to V <sub>CC</sub> or ground.
3	24	RESET	Active-low reset input. Connect to V <sub>CC</sub> through a pullup resistor if no active connection is used.
4	1	P00	P-port input/output. Push-pull design structure.
5	2	P01	P-port input/output. Push-pull design structure.
6	3	P02	P-port input/output. Push-pull design structure.
7	4	P03	P-port input/output. Push-pull design structure.
8	5	P04	P-port input/output. Push-pull design structure.
9	6	P05	P-port input/output. Push-pull design structure.
10	7	P06	P-port input/output. Push-pull design structure.
11	8	P07	P-port input/output. Push-pull design structure.
12	9	GND	Ground
13	10	P10	P-port input/output. Push-pull design structure.
14	11	P11	P-port input/output. Push-pull design structure.
15	12	P12	P-port input/output. Push-pull design structure.
16	13	P13	P-port input/output. Push-pull design structure.
17	14	P14	P-port input/output. Push-pull design structure.
18	15	P15	P-port input/output. Push-pull design structure.
19	16	P16	P-port input/output. Push-pull design structure.
20	17	P17	P-port input/output. Push-pull design structure.
21	18	A0	Address input. Connect directly to V <sub>CC</sub> or ground.
22	19	SCL	Serial clock bus. Connect to V <sub>CC</sub> through a pullup resistor.
23	20	SDA	Serial data bus. Connect to V <sub>CC</sub> through a pullup resistor.
24	21	V <sub>CC</sub>	Supply voltage

## HIN202EIBNZ-T (8U-210094-1 : IC403)

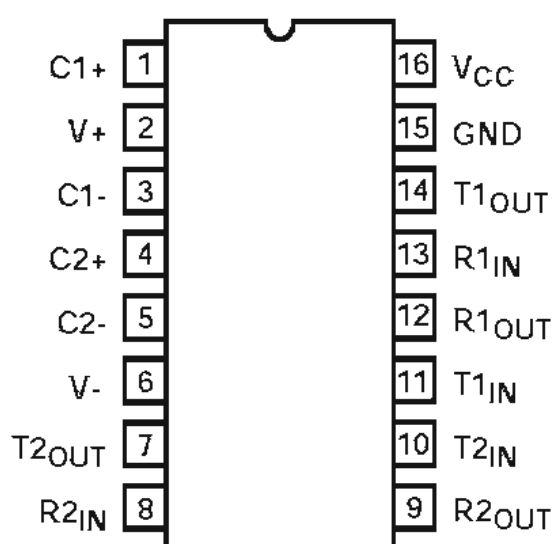

### HIN202EIBNZ-T Pin Function

PIN	FUNCTION
V <sub>CC</sub>	Power Supply Input 5V ±10%, (5V ±5% HIN207E).
V+	Internally generated positive supply (+10V nominal).
V-	Internally generated negative supply (-10V nominal).
GND	Ground Lead. Connect to 0V.
C1+	External capacitor (+ terminal) is connected to this lead.
C1-	External capacitor (- terminal) is connected to this lead.
C2+	External capacitor (+ terminal) is connected to this lead.
C2-	External capacitor (- terminal) is connected to this lead.
T <sub>IN</sub>	Transmitter Inputs. These leads accept TTL/CMOS levels. An internal 400k pull-up resistor to V <sub>CC</sub> is connected to each lead.
T <sub>OUT</sub>	Transmitter Outputs. These are RS-232 levels (nominally ±10V).
R <sub>IN</sub>	Receiver Inputs. These inputs accept RS-232 input levels. An internal 5k pull-down resistor to GND is connected to each input.
R <sub>OUT</sub>	Receiver Outputs. These are TTL/CMOS levels.
$\overline{EN}$ , EN	Receiver Enable Input. With $\overline{EN} = 5V$ (HIN213E EN=0V), the receiver outputs are placed in a high impedance state.
SD, $\overline{SD}$	Shutdown Input. With SD = 5V (HIN213E $\overline{SD} = 0V$ ), the charge pump is disabled, the receiver outputs are in a high impedance state (except R4 and R5 of HIN213E) and the transmitters are shut off.
NC	No Connect. No connections are made to these leads.



--MEMO--

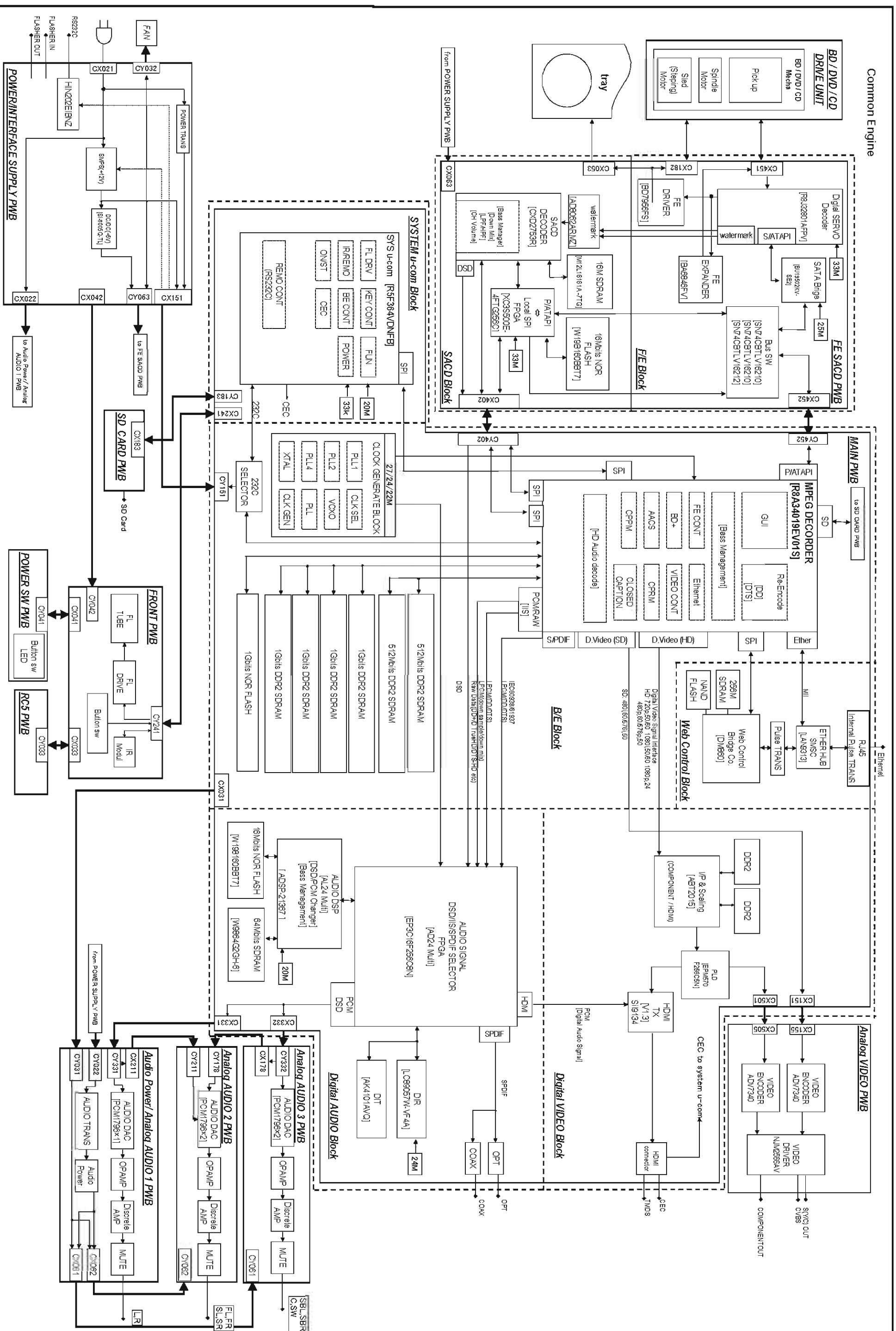

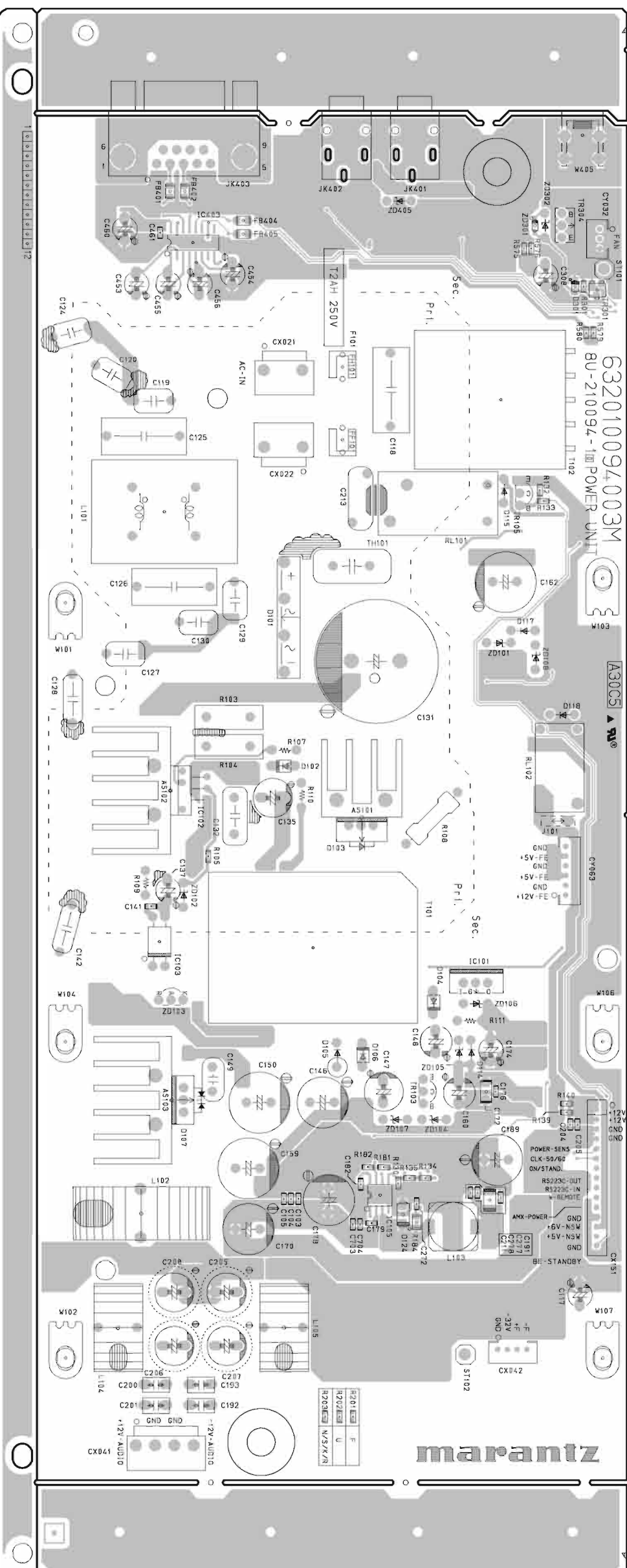
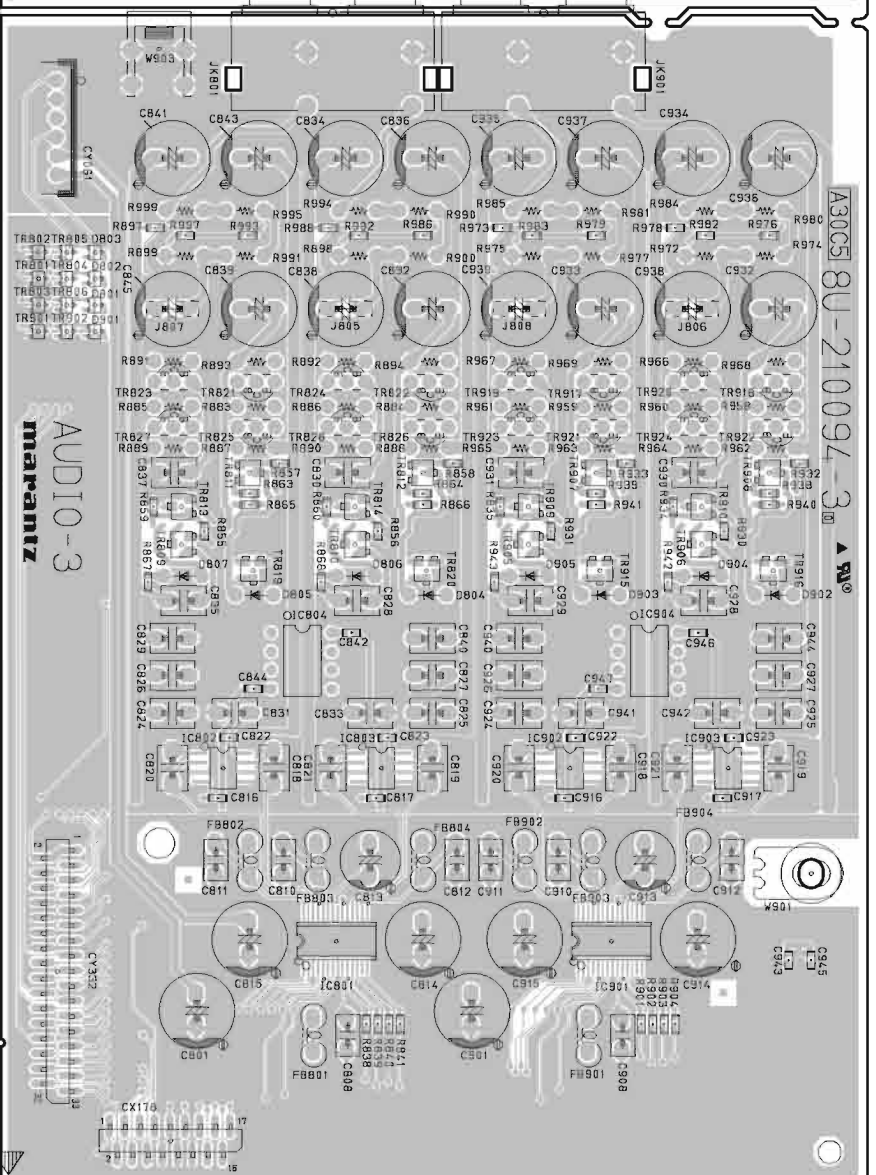
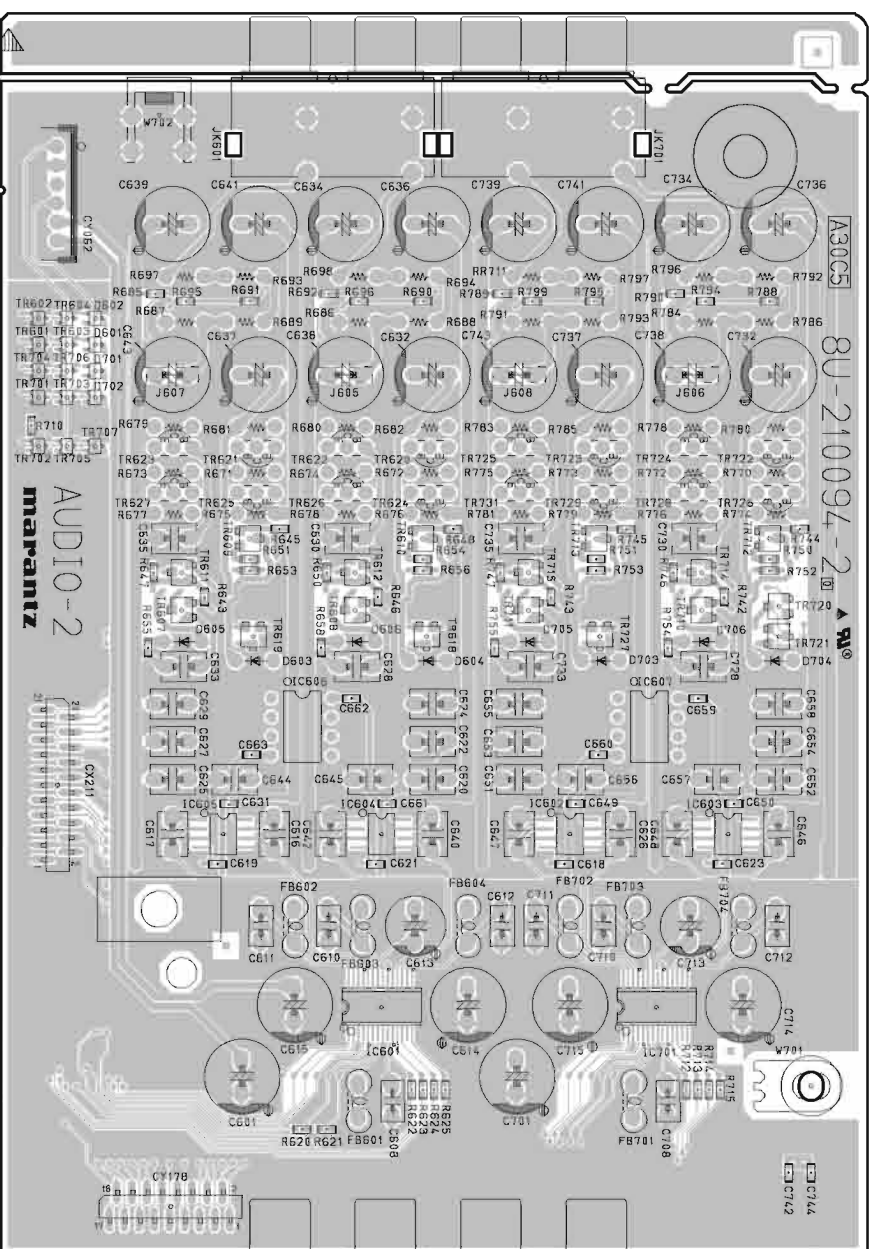



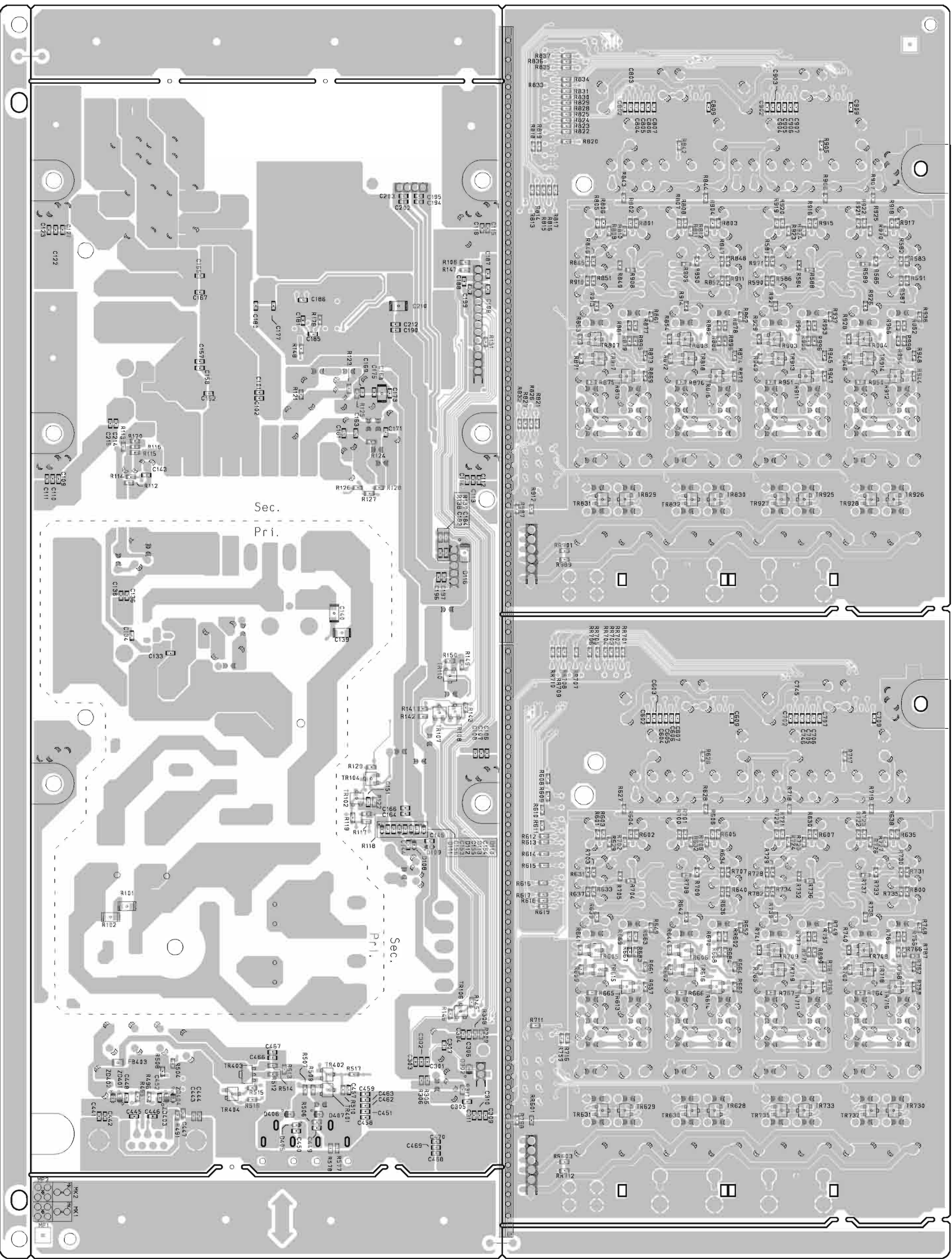

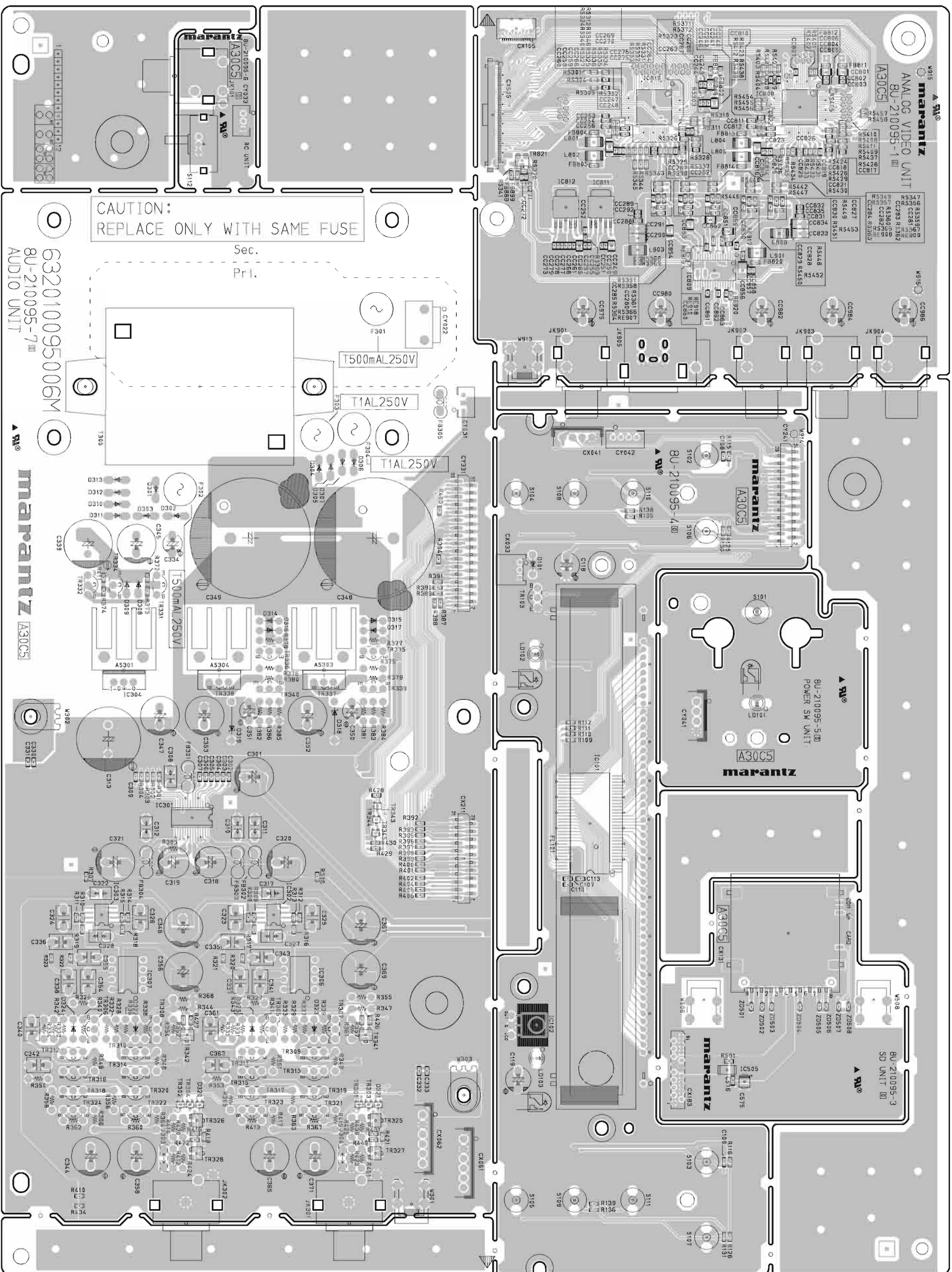

CAUTION:  
REPLACE ONLY WITH SAME FUSE

Sec.  
Pri.

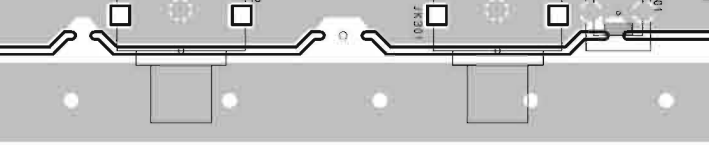
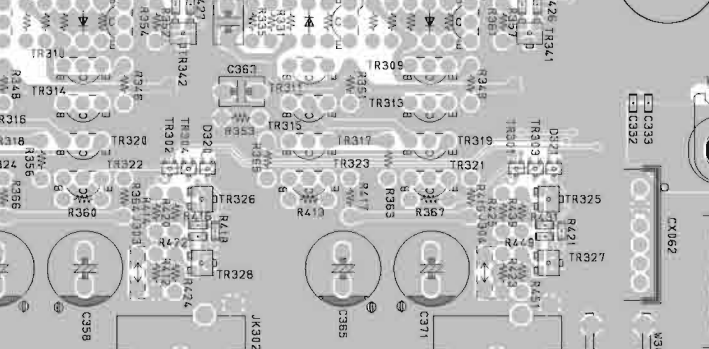
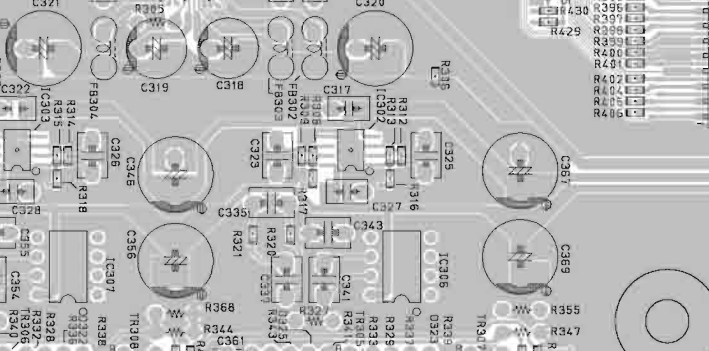
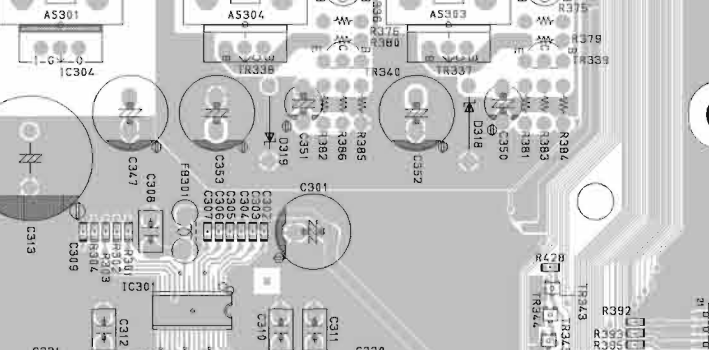
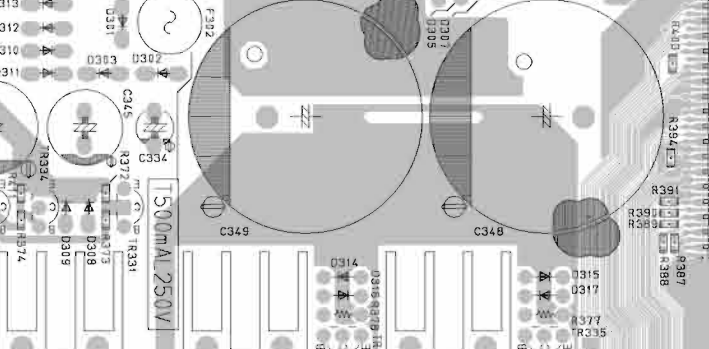
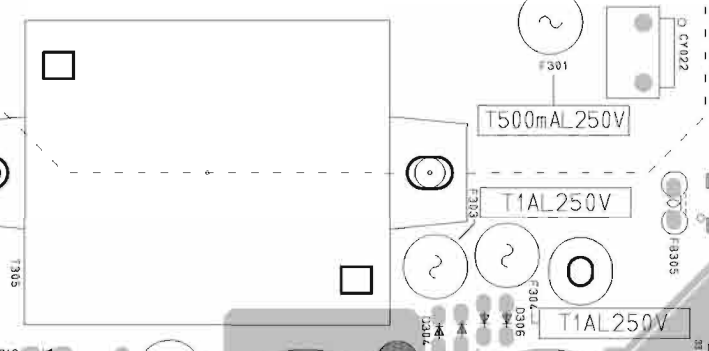

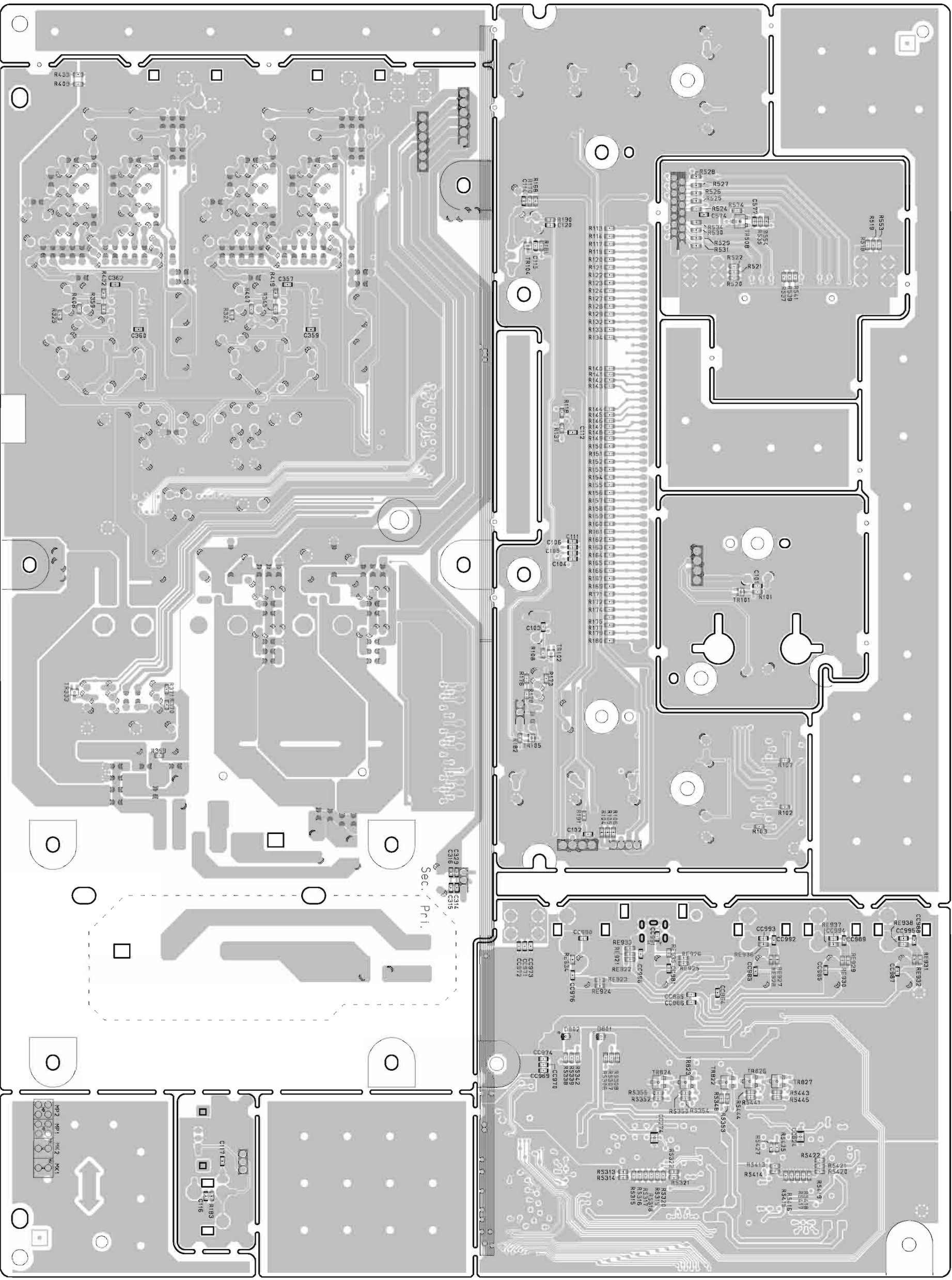

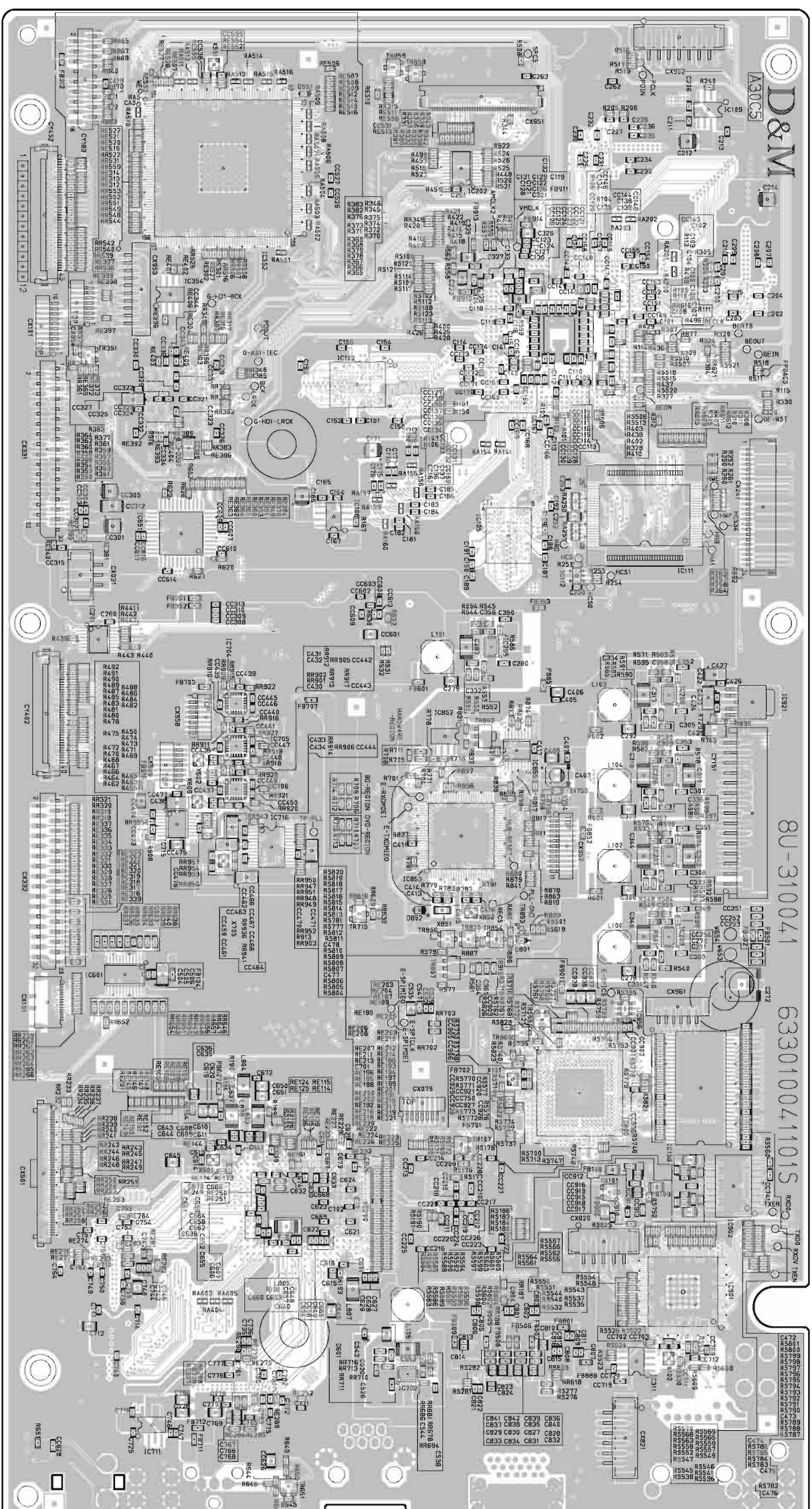

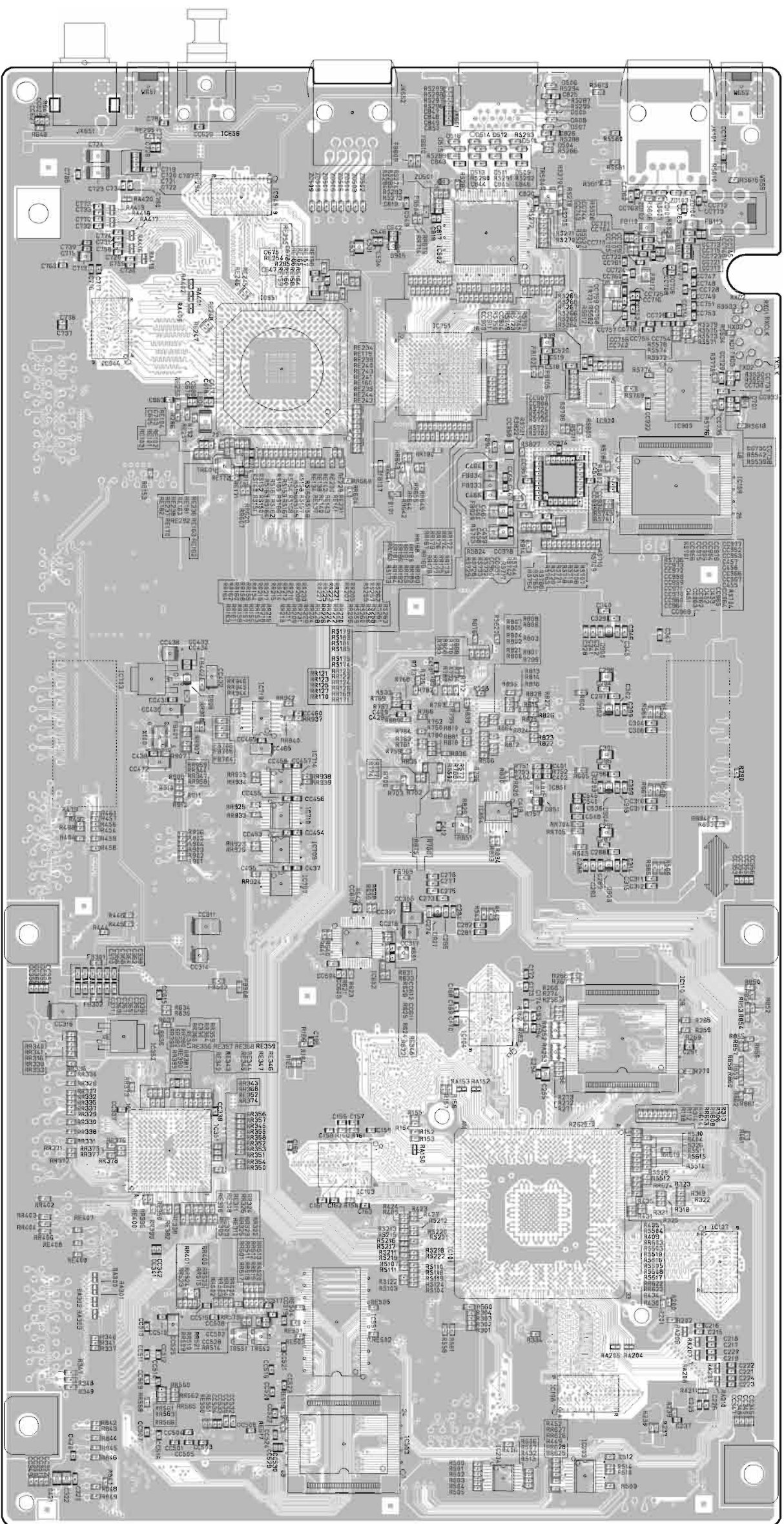

FOIL SIDE

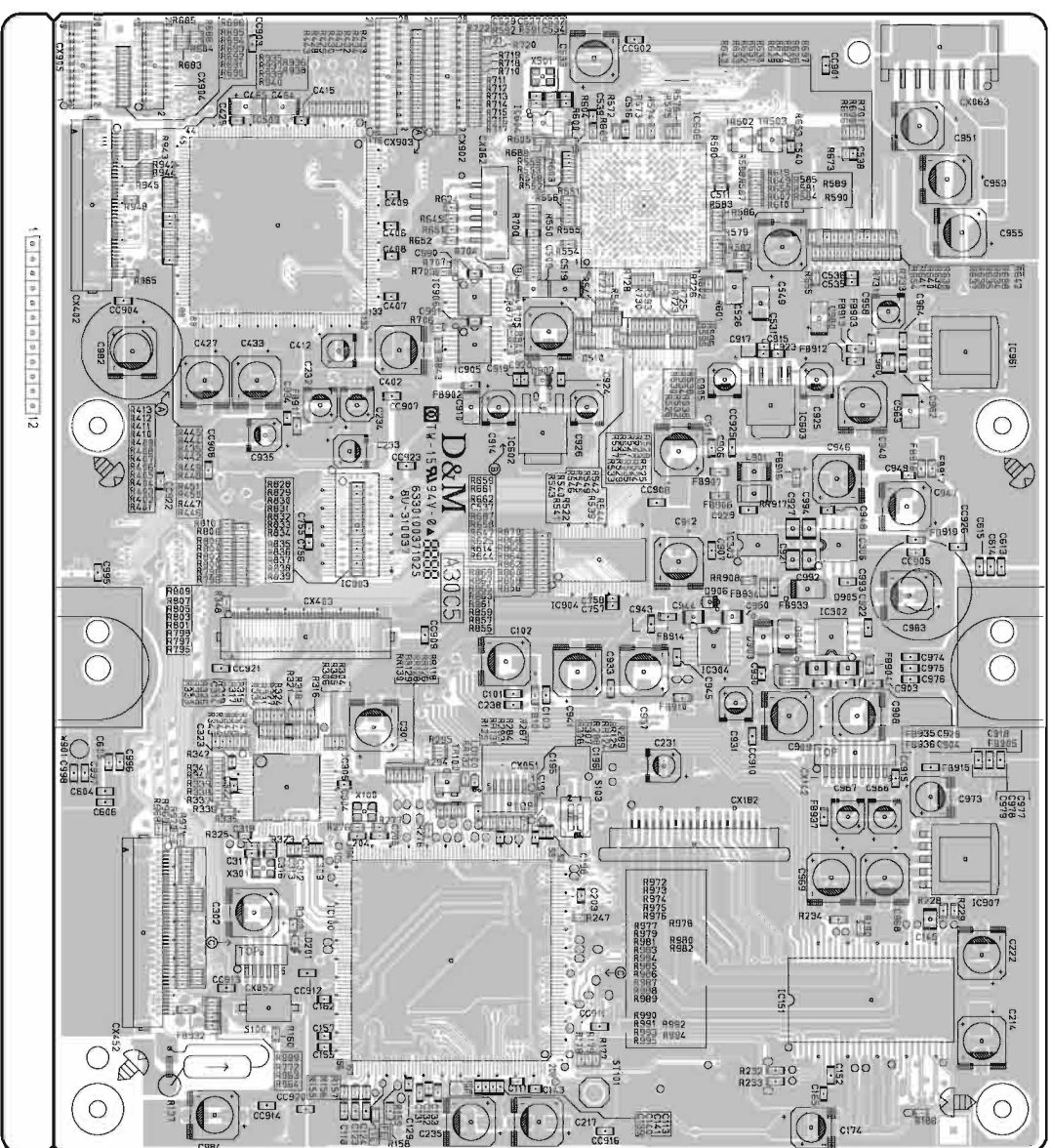

COMPONENT SIDE

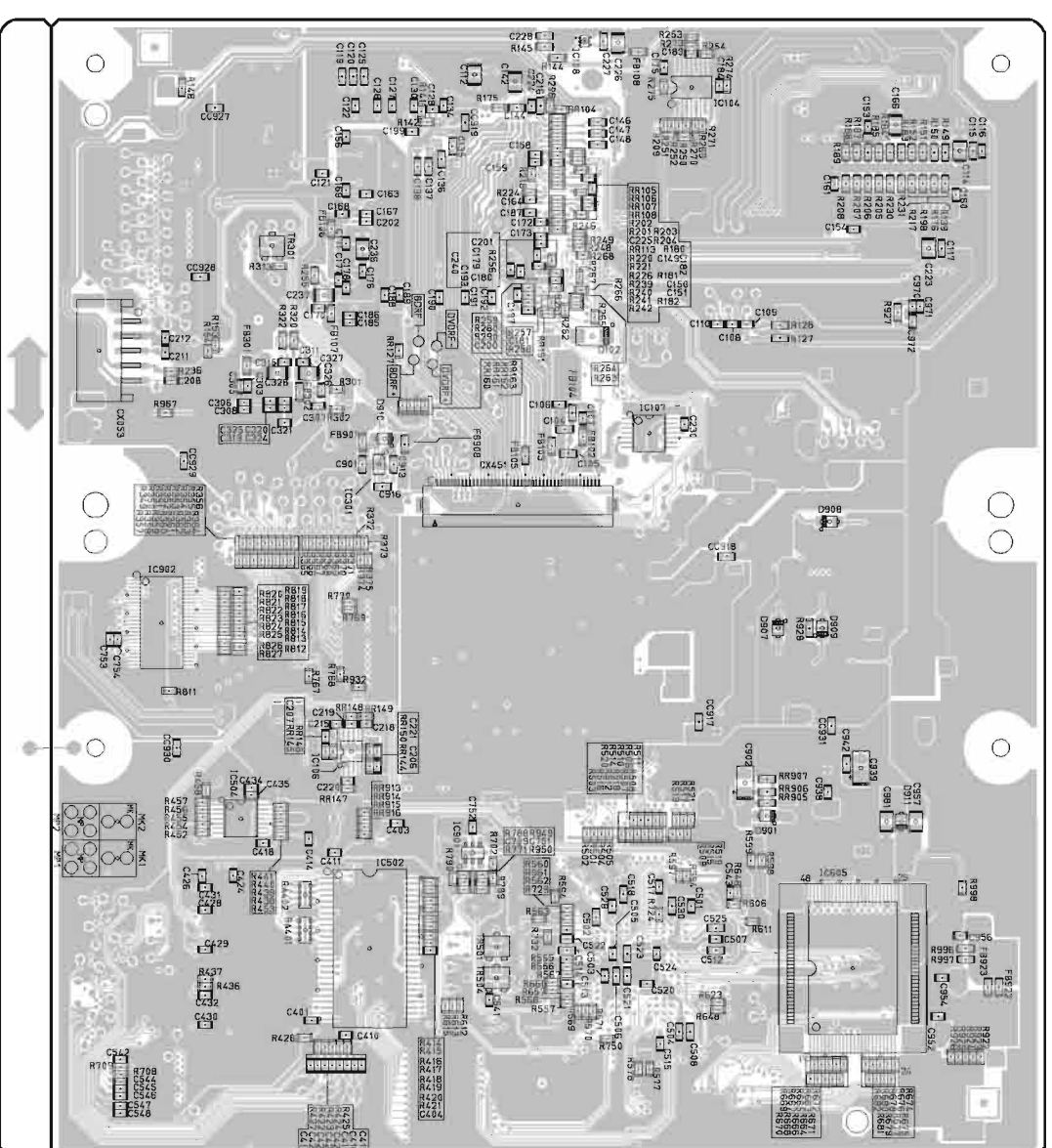

FOIL SIDE

# NOTE FOR PARTS LIST

1. Parts for which "nsp" is indicated on this table cannot be supplied.
2. When ordering of part, clearly indicate "I" and "I" (i) to avoid mis-supplying.
3. Ordering part without stating its part number can not be supplied.
4. Part indicated with the mark "★" is not illustrated in the exploded view.
5. Not including General-purpose Carbon Film Resistor in the P.W.Board parts list. (Refer to the Schematic Diagram for those parts.)
6. Not including General-purpose Carbon Chip Resistor in the P.W.Board parts list. (Refer to the Schematic Diagram for those parts.)

**WARNING:**

Parts marked with this symbol  $\triangle$  have critical characteristics.  
Use ONLY replacement parts recommended by the manufacturer.

● Resistors

Ex.:      RN      14K      2E      182      G      FR

Type      Shape and performance      Power      Resistance      Allowable error      Others

RD : Carbon	2B : 1/8 W	F : ±1%	P : Pulse-resistant type
RC : Composition	2E : 1/4 W	G : ±2%	NL : Low noise type
RS : Metal oxide film	2H : 1/2 W	J : ±5%	NB : Non-burning type
RW : winding	3A : 1 W	K : ±10%	FR : Fuse-resistor
RN : Metal film	3D : 2 W	M : ±20%	F : Lead wire forming
RK : Metal mixture	3F : 3 W		
	3H : 5 W		

\* Resistance

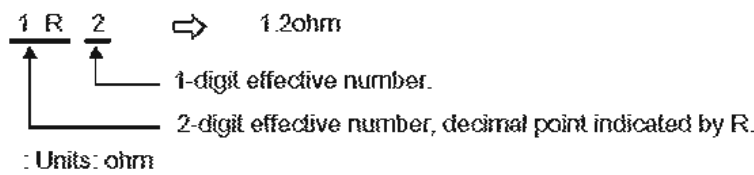
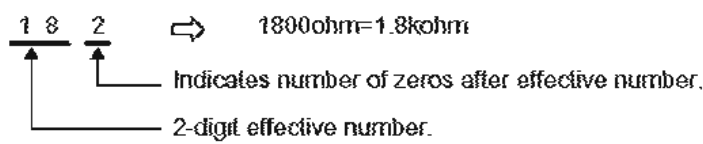

● Capacitors

Ex.:      CE      04W      1H      3R2      M      BP

Type      Shape and performance      Dielectric strength      Capacity      Allowable error      Others

CE : Aluminum foil electrolytic	0J : 6.3 V	F : ±1%	HS : High stability type
CA : Aluminium solid electrolytic	1A : 10 V	G : ±2%	BP : Non-polar type
CS : Tantatum electrolytic	1C : 16 V	J : ±5%	HR : Ripple-resistant type
CQ : Film	1E : 25 V	K : ±10%	DL : For charge and discharge
CK : Ceramic	1V : 35 V	M : ±20%	HF : For assuring high requency
CC : Ceramic	1H : 50 V	Z : ±80%	U : UL part
CP : Oil	2A : 100 V	: -20%	C : CSA part
CM : Mica	2B : 125 V	P : +100%	W : UL-CSA part
CF : Metallized	2C : 160 V	C : ±0.25pF	F : Lead wire forming
CH : Metallized	2D : 200 V	D : ±0.5pF	
	2E : 250 V	= : Others	
	2H : 500 V		
	2J : 630 V		

\* Capacity (electrolyte only)

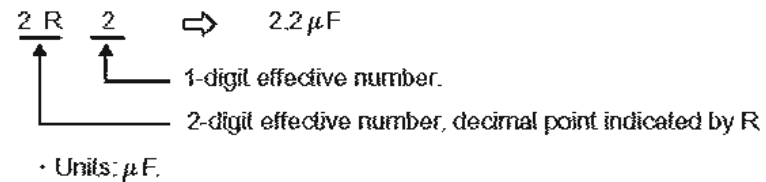
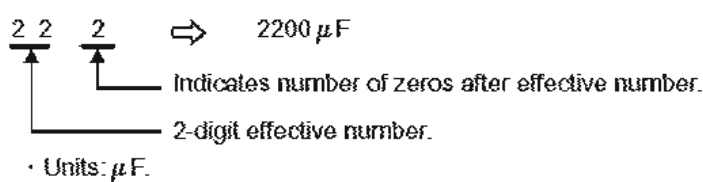

\* Capacity (except electrolyte)

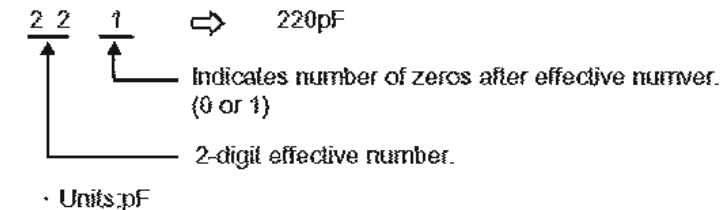
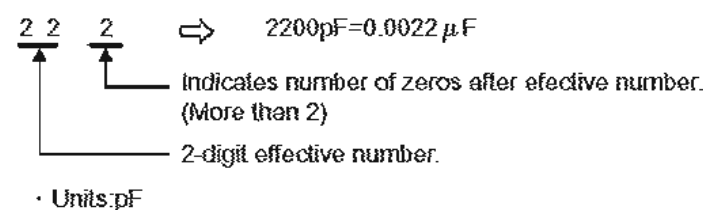

When the dielectric strength is indicated in AC, "AC" is included after the dielectric strength value.

# PARTS LIST OF P.W.B. UNIT

\* Parts for which "nsp" is indicated on this table cannot be supplied.

\* The parts listed below are for maintenance only, might differ from the parts used in the unit in appearances or dimensions.

Note: The symbols in the column "Remarks" indicate the following destinations.

U : North America model

N : Europe model

R : Russia model

S : Singapore model

K : Chaina model

## 8U-210094A AUDIO/POWER PWB UNIT ASSY(U model)

## 8U-210094C AUDIO/POWER PWB UNIT ASSY(N, R, S, K model)

Ref. No.	Part No.	Part Name	Remarks	Q'ty	New
<b>SEMICONDUCTORS GROUP</b>					
△	IC102	231010077702S	STR-Y6453	U	
△	IC102	231010077719S	STR-Y6473	N, R, S, K	
	IC103	00D2623047008	PC123Y22		
	IC105	231810041507S	SI-8005Q-TL		
	IC403	00D2623571901	HIN202EIBNZ-T		
	IC601	00D2623362903	PCM1796DBR		
	IC602-605	00D2630896909	NJM2068MD-TE1 +C		
	IC606,607	00D2630609002	NJM2068DDC +T		
	IC701	00D2623362903	PCM1796DBR		
	IC801	00D2623362903	PCM1796DBR		
	IC802,803	00D2630896909	NJM2068MD-TE1 +C		
	IC804	00D2630609002	NJM2068DDC +T		
	IC901	00D2623362903	PCM1796DBR		
	IC902,903	00D2630896909	NJM2068MD-TE1 +C		
	IC904	00D2630609002	NJM2068DDC +T		
	TR102	00D2730464901	KTC3875S-GR-RTK/P		
	TR103	00D2720025907	2SB562(C)TF		
	TR104	00D2690082902	DTC114EKT96 +C	U	
	TR105	00D2730468907	KTC3199-GR-AT/P		
	TR106	00D2690192902	KRC102S-RTK/P (10K-10K)		
	TR110	00D2730464901	KTC3875S-GR-RTK/P		
	TR304	00D2740188905	2SD1858TV2(Q/R)		
	TR401	00D2730464901	KTC3875S-GR-RTK/P		
	TR402	00D2690191903	KRA104S-RTK/P (47K-47K)		
	TR403	00D2720160901	2SB1132T100Q +C		
	TR404	00D2690054901	DTC144EKT96 +C		
	TR601,602	00MBA20035210	DTC114EU		
	TR603,604	00MBA10026210	DTA114EU		
	TR605,606	00D2710259903	2SA1162-GR(TE85L)		
	TR607-610	00D2730403904	2SC2712-Y/GR(TE85L) +C		
	TR611-614	00D2710259903	2SA1162-GR(TE85L)		
	TR615,616	00D2730403904	2SC2712-Y/GR(TE85L) +C		
	TR620,621	00MHT600121A0	KTA1268 PNP TRANSISTOR RANK=GR		
	TR622-625	00MHT800931A0	KTC3200 NPN TRANSISTOR RANK=GR		
	TR626,627	00MHT600121A0	KTA1268 PNP TRANSISTOR RANK=GR		
	TR628-631	00D2730460905	KTC2875-B-RTK/P		
	TR701,702	00MBA20035210	DTC114EU		
	TR703	00MBA10026210	DTA114EU		
	TR704,705	00MBA20035210	DTC114EU		
	TR706,707	00MBA10026210	DTA114EU		
	TR708,709	00D2710259903	2SA1162-GR(TE85L)		
	TR710-713	00D2730403904	2SC2712-Y/GR(TE85L) +C		
	TR714-717	00D2710259903	2SA1162-GR(TE85L)		
	TR718,719	00D2730403904	2SC2712-Y/GR(TE85L) +C		
	TR721	00D2730460905	KTC2875-B-RTK/P		
	TR722,723	00MHT600121A0	KTA1268 PNP TRANSISTOR RANK=GR		
	TR724-726	00MHT800931A0	KTC3200 NPN TRANSISTOR RANK=GR		
	TR728	00MHT600121A0	KTA1268 PNP TRANSISTOR RANK=GR		
	TR729	00MHT800931A0	KTC3200 NPN TRANSISTOR RANK=GR		
	TR730	00D2730460905	KTC2875-B-RTK/P		



	Ref. No.	Part No.	Part Name	Remarks	Q'ty	New
	TR731 TR732,733 TR735	00MHT600121A0 00D2730460905 00D2730460905	KTA1268 PNP TRANSISTOR RANK=GR KTC2875-B-RTK/P KTC2875-B-RTK/P			
	TR801-803 TR804-806 TR807,808 TR809-812 TR813-816	00MBA20035210 00MBA10026210 00D2710259903 00D2730403904 00D2710259903	DTC114EU DTA114EU 2SA1162-GR(TE85L) 2SC2712-Y/GR(TE85L) +C 2SA1162-GR(TE85L)			
	TR817,818 TR821,822 TR823-826 TR827,828 TR829-832	00D2730403904 00MHT600121A0 00MHT800931A0 00MHT600121A0 00D2730460905	2SC2712-Y/GR(TE85L) +C KTA1268 PNP TRANSISTOR RANK=GR KTC3200 NPN TRANSISTOR RANK=GR KTA1268 PNP TRANSISTOR RANK=GR KTC2875-B-RTK/P			
	TR901 TR902 TR903,904 TR905-908 TR909-912	00MBA20035210 00MBA10026210 00D2710259903 00D2730403904 00D2710259903	DTC114EU DTA114EU 2SA1162-GR(TE85L) 2SC2712-Y/GR(TE85L) +C 2SA1162-GR(TE85L)			
	TR913,914 TR917,918 TR919-922 TR923,924 TR925-928	00D2730403904 00MHT600121A0 00MHT800931A0 00MHT600121A0 00D2730460905	2SC2712-Y/GR(TE85L) +C KTA1268 PNP TRANSISTOR RANK=GR KTC3200 NPN TRANSISTOR RANK=GR KTA1268 PNP TRANSISTOR RANK=GR KTC2875-B-RTK/P			
△	D101 D102 D103 D104	00D2760767005 00D2760727919 00D2760758001 00D2760727919	RBV-406 AL01ZT (WK) SARS03 AL01ZT (WK)			
△	D106 D107 D108-113 D115 D117	00D2760727919 204050011708S 00D2760750902 00D2760401905 00MHD20002710	AL01ZT (WK) FME-210B RB521S-30TE61 +REF 1SS133T77 (TAPE) 1D3 1A/200V			
	D118 D124 D302 D405 D406,407	00D2760401905 203850012502S 00D2760794900 00D2760750902 00D2760794900	1SS133T77 (TAPE) SJPB-L4 KDS160-RTK/P RB521S-30TE61 +REF KDS160-RTK/P			
	D601,602 D603-606 D701,702 D703-706 D801-803	00MHZ21005000 00D2760401905 00MHZ21005000 00D2760401905 00MHZ21005000	1SS301 DAN202U UMT TYPE 1SS133T77 (TAPE) 1SS301 DAN202U UMT TYPE 1SS133T77 (TAPE) 1SS301 DAN202U UMT TYPE			
	D804-807 D901 D902-905  ZD101	00D2760401905 00MHZ21005000 00D2760401905  00D2760761959	1SS133T77 (TAPE) 1SS301 DAN202U UMT TYPE 1SS133T77 (TAPE)  MTZJ15B T77			U
△	ZD102 ZD103 ZD104 ZD105 ZD107	00D2760636903 00D2631185907 00D2760665903 00D2760760905 00D2760665903	MTZJ8.2BT77 TL431ACLP MTZJ16B T77 MTZJ3.6B T77 MTZJ16B T77			
	ZD302 ZD405	00D2760761904 00D2760760963	MTZJ9.1B T77 MTZJ6.2B T77			
△	TH101	00D2790044002	NTH11D8R0LA			

Ref. No.	Part No.	Part Name	Remarks	Q'ty	New
<b>RESISTORS GROUP</b>					
R101	129550003504S	RM73B2E115JT(HV732B)			
R102	129550003504S	RM73B2E115JT(HV732B)			
R104	00D2432094064	RW99=3DR33JF	U		
R104	00D2432094077	RW99=3DR47JF	N, R, S, K		
R108	00D2442675716	RS14B3D683JNBF (ERG)			
R115	00D2472035986	RM73B-332DT(1608)			
R116	00D2472042911	RM73B-123DT(1608)			
R120	00D2472034916	RM73B-561DT(1608)			
R130	00D2472041925	RM73B-472DT(1608)			
R134	00D2472035986	RM73B-332DT(1608)			
R135	00D2472036985	RM73B-393DT(1608)			
R142	00D2472036930	RM73B-243DT(1608)			
R143	00D2472041925	RM73B-472DT(1608)			
R202	00D2472018903	RM73B-0R0KT +1608/	U		
R203	00D2472018903	RM73B-0R0KT +1608/	N, R, S, K		
<b>CAPACITORS GROUP</b>					
C106	nsp	CK73B1H103KT (1608) +1608			
C107	nsp	CK73B1H102KT +1608			
C108	nsp	CC73CH1H101JT +1608			
C109	nsp	CK73B1H103KT (1608) +1608			
C110	nsp	CK73B1H102KT +1608			
C111	nsp	CC73CH1H101JT +1608			
C112	nsp	CK73B1H103KT (1608) +1608			
C113	nsp	CK73B1H102KT +1608			
C114	nsp	CC73CH1H101JT +1608			
C115	nsp	RM73B-0R0KT +1608			
C116	nsp	RM73B-0R0KT +1608			
C117	00D2544722949	CE04W1H010MT(GR)			
△ C118	00D2568039029	CF99--2EAC334K(LEMX)			
△ C119	00D2538035710	CK45E2EAC222MC(KY)			
△ C120	00D2538035710	CK45E2EAC222MC(KY)			
C121	nsp	CK73B1H103KT (1608) +1608			
C122	nsp	CC73CH1H101JT +1608			
C123	nsp	CK73B1H102KT +1608			
△ C124	00D2538035710	CK45E2EAC222MC(KY)	U		
△ C126	00D2568039029	CF99--2EAC334K(LEMX)			
△ C128	00D2538029713	CK45F2EAC471KC(KX)			
C131	134010168202S	CE68W2D331M Q25(KMM)	U		
C131	134010168226S	CE68W2G121M Q25(KMM)	N, R, S, K		
C132	132050024205S	CK45B3D102KC(DEHR)	U		
C132	132050023202S	CK45B3D471KC(DEHR)	N, R, S, K		
C134	nsp	CK73B1A224KT +1608			
C135	134050069402S	CE04W2A270MT HB5(KY)			
C137	00D2544524972	CE04W1H4R7MT SMG/RE3			
C139	132510036571S	CK73B2J153KT(3216)			
C140	132510036571S	CK73B2J153KT(3216)			
C141	nsp	CK73B1H472KT +1608			
C142	00D2538029700	CK45F2EAC222MC (KX)			
C143	nsp	CK73F1E104ZT +1608			
C144	nsp	CK73B1E223KT +1608			
C145	nsp	CK73B1E223KT +1608			
C147	134050069402S	CE04W2A270MT HB5(KY)			
C148	00D2544711918	CE04W1A221MT F11(KY)			
C149	00D2534548706	CC45R3A102KC			
C150	00D2544806700	CE04W1C222MC K25(KY)			
C151	00D2570517908	CK73B1C473KT +1608			
C152	132350030504S	CK73B1C225KT 1608			
C153	nsp	CK73B1H103KT (1608) +1608			
C154	nsp	CK73B1H103KT (1608) +1608			

Ref. No.	Part No.	Part Name	Remarks	Q'ty	New
C155	nsp	CK73B1H103KT (1608) +1608			
C156	nsp	CK73B1H103KT (1608) +1608			
C157	132350030504S	CK73B1C225KT 1608			
C158	nsp	CK73B1H102KT +1608			
C159	00D2544806700	CE04W1C222MC K25(KY)			
C160	00D2544755903	CE04W1H560MT(KY)			
C161	132350030504S	CK73B1C225KT 1608			
C162	00D2544806700	CE04W1C222MC K25(KY)			
C163	132350030504S	CK73B1C225KT 1608			
C164	nsp	CK73F1E104ZT +1608			
C165	132350030504S	CK73B1C225KT 1608			
C166	nsp	CK73B1H102KT +1608			
C167	nsp	CK73B1H102KT +1608			
C169	nsp	CK73B1H102KT +1608			
C170	134050090208S	CE04W1C102MC J20(KY)			
C171	132350030504S	CK73B1C225KT 1608			
C173	nsp	CK73B1H102KT +1608			
C174	00D2544717925	CE04W1A101MT(GR)			
C175	132350036502S	CK73R1H104KT (1608)			
C176	132350036502S	CK73R1H104KT (1608)			
C177	nsp	CK73B1H102KT +1608			
C178	134050090208S	CE04W1C102MC J20(KY)			
C179	132350030504S	CK73B1C225KT 1608			
C180	nsp	CK73F1E104ZT +1608			
C182	132350036502S	CK73R1H104KT (1608)			
C183	nsp	CK73B1H103KT (1608) +1608			
C184	nsp	CK73B1H102KT +1608			
C185	nsp	CK73B1H102KT +1608			
C186	nsp	CK73B1H103KT (1608) +1608			
C187	nsp	CK73B1H103KT (1608) +1608			
C188	nsp	CK73B1H102KT +1608			
C190	nsp	CK73F1E104ZT +1608			
C191	nsp	CK73B1H102KT +1608			
C194	nsp	CK73B1H103KT (1608) +1608			
C195	nsp	CK73B1H102KT +1608			
C196	nsp	CK73B1H103KT (1608) +1608			
C197	nsp	CK73B1H102KT +1608			
C198	nsp	CK73B1H103KT (1608) +1608			
C199	nsp	CK73B1H102KT +1608			
C202	nsp	CK73B1H103KT (1608) +1608			
C203	nsp	CK73B1H102KT +1608			
C204	nsp	CK73B1H103KT (1608) +1608			
C205	nsp	CK73B1H102KT +1608			
C211	132350030504S	CK73B1C225KT 1608			
C213	00D2538026703	CK45E2EAC472MC			
C272	nsp	CK73B1H222KT +1608			
C277	00MDK26476010	GRM32EB31C476KE15L			
C278	132350030504S	CK73B1C225KT 1608			
C301	nsp	CK73F1E104ZT +1608			
C302	nsp	CK73B1H103KT (1608) +1608			
C303	nsp	CK73F1E104ZT +1608			
C304	nsp	CK73F1E104ZT +1608			
C305	nsp	CK73F1E104ZT +1608			
C308	00D2544718937	CE04W1C470MT(GR)			
C309	nsp	CK73B1H103KT (1608) +1608			
C310	nsp	CK73B1H102KT +1608			
C311	nsp	CC73CH1H101JT +1608			
C443	nsp	RM73B--0R0KT +1608			
C444	nsp	RM73B--0R0KT +1608			
C445	nsp	CC73CH1H101JT +1608			
C446	nsp	CC73CH1H101JT +1608			

Ref. No.	Part No.	Part Name	Remarks	Q'ty	New
C447	nsp	RM73B--0R0KT +1608			
C449	nsp	CK73B1H102KT +1608			
C450	nsp	CK73F1E104ZT +1608			
C451	nsp	CK73F1E104ZT +1608			
C453	00D2544722907	CE04W1H0R1MT(GR)			
C454	00D2544722907	CE04W1H0R1MT(GR)			
C455	00D2544722907	CE04W1H0R1MT(GR)			
C456	00D2544722907	CE04W1H0R1MT(GR)			
C458	nsp	CC73CH1H221JT +1608			
C460	00D2544718937	CE04W1C470MT(GR)			
C461	nsp	CK73F1E104ZT +1608			
C462	nsp	CC73CH1H221JT +1608			
C463	nsp	CK73F1E104ZT +1608			
C466	nsp	CK73B1H103KT (1608) +1608			
C468	nsp	CC73CH1H101JT +1608			
C469	nsp	CK73B1H102KT +1608			
C470	nsp	CK73B1H103KT (1608) +1608			
C601	00MOA107025R0	ROA-25V 101M -H4#PE - T2 (100UF 25V)			
C608	nsp	0.1UF 50V +- 5% MTFVA0050J104			
C609	nsp	CK73F1E104ZT +1608			
C610	nsp	0.1UF 50V +- 5% MTFVA0050J104			
C611	nsp	0.1UF 50V +- 5% MTFVA0050J104			
C612	nsp	0.1UF 50V +- 5% MTFVA0050J104			
C613	00MOA476016Z0	ROS-16V 470M - G3#PE - T2 (47UF 16V)			
C614	00MOA107025R0	ROA-25V 101M -H4#PE - T2 (100UF 25V)			
C615	00MOA107025R0	ROA-25V 101M -H4#PE - T2 (100UF 25V)			
C616	nsp	1000PF J 100V APSV			
C617	nsp	1000PF J 100V APSV			
C618	nsp	CK73F1E104ZT +1608			
C619	nsp	CK73F1E104ZT +1608			
C620	nsp	100PF J 100V APSV			
C621	nsp	CK73F1E104ZT +1608			
C622	nsp	1000PF J 100V APSV			
C623	nsp	CK73F1E104ZT +1608			
C624	nsp	APSV 221J,220PF(TP) 100V PP			
C625	nsp	100PF J 100V APSV			
C626	nsp	1000PF J 100V APSV			
C627	nsp	1000PF J 100V APSV			
C628	nsp	100PF J 100V APSV			
C629	nsp	APSV 221J,220PF(TP) 100V PP			
C630	nsp	APSV 471J,470PF(TP) 100V PP			
C631	nsp	CK73F1E104ZT +1608			
C632	00MOA227016Z0	ROS-16V 221M - H5#PE - T2 (220UF 16V)			
C633	nsp	100PF J 100V APSV			
C634	00MOA227025R0	ROA-25V 221M -H5#PE - T2 (220UF 25V)			
C635	nsp	APSV 471J,470PF(TP) 100V PP			
C636	00MOA227025R0	ROA-25V 221M -H5#PE - T2 (220UF 25V)			
C637	00MOA227016Z0	ROS-16V 221M - H5#PE - T2 (220UF 16V)			
C638	00MOA227016Z0	ROS-16V 221M - H5#PE - T2 (220UF 16V)			
C639	00MOA227025R0	ROA-25V 221M -H5#PE - T2 (220UF 25V)			
C640	nsp	1000PF J 100V APSV			
C641	00MOA227025R0	ROA-25V 221M -H5#PE - T2 (220UF 25V)			
C642	nsp	1000PF J 100V APSV			
C643	00MOA227016Z0	ROS-16V 221M - H5#PE - T2 (220UF 16V)			
C644	nsp	APSV 221J,220PF(TP) 100V PP			
C645	nsp	APSV 221J,220PF(TP) 100V PP			
C646	nsp	1000PF J 100V APSV			
C647	nsp	1000PF J 100V APSV			
C648	nsp	1000PF J 100V APSV			
C649	nsp	CK73F1E104ZT +1608			
C650	nsp	CK73F1E104ZT +1608			

Ref. No.	Part No.	Part Name	Remarks	Q'ty	New
C651	nsp	100PF J 100V APSV			
C652	nsp	100PF J 100V APSV			
C653	nsp	1000PF J 100V APSV			
C654	nsp	1000PF J 100V APSV			
C655	nsp	APSV 221J,220PF(TP) 100V PP			
C656	nsp	APSV 221J,220PF(TP) 100V PP			
C657	nsp	APSV 221J,220PF(TP) 100V PP			
C658	nsp	APSV 221J,220PF(TP) 100V PP			
C659	nsp	CK73F1E104ZT +1608			
C660	nsp	CK73F1E104ZT +1608			
C661	nsp	CK73F1E104ZT +1608			
C662	nsp	CK73F1E104ZT +1608			
C663	nsp	CK73F1E104ZT +1608			
C701	00MOA107025R0	ROA-25V 101M -H4#PE - T2 (100UF 25V)			
C703	132350030504S	CK73B1C225KT 1608			
C704	132350030504S	CK73B1C225KT 1608			
C708	nsp	0.1UF 50V +- 5% MTFVA0050J104			
C709	nsp	CK73F1E104ZT +1608			
C710	nsp	0.1UF 50V +- 5% MTFVA0050J104			
C711	nsp	0.1UF 50V +- 5% MTFVA0050J104			
C712	nsp	0.1UF 50V +- 5% MTFVA0050J104			
C713	00MOA476016Z0	ROS-16V 470M - G3#PE - T2 (47UF 16V)			
C714	00MOA107025R0	ROA-25V 101M -H4#PE - T2 (100UF 25V)			
C715	00MOA107025R0	ROA-25V 101M -H4#PE - T2 (100UF 25V)			
C728	nsp	100PF J 100V APSV			
C730	nsp	APSV 471J,470PF(TP) 100V PP			
C732	00MOA227016Z0	ROS-16V 221M - H5#PE - T2 (220UF 16V)			
C733	nsp	100PF J 100V APSV			
C734	00MOA227025R0	ROA-25V 221M -H5#PE - T2 (220UF 25V)			
C735	nsp	APSV 471J,470PF(TP) 100V PP			
C736	00MOA227025R0	ROA-25V 221M -H5#PE - T2 (220UF 25V)			
C737	00MOA227016Z0	ROS-16V 221M - H5#PE - T2 (220UF 16V)			
C738	00MOA227016Z0	ROS-16V 221M - H5#PE - T2 (220UF 16V)			
C739	00MOA227025R0	ROA-25V 221M -H5#PE - T2 (220UF 25V)			
C741	00MOA227025R0	ROA-25V 221M -H5#PE - T2 (220UF 25V)			
C742	nsp	CK73F1E104ZT +1608			
C743	00MOA227016Z0	ROS-16V 221M - H5#PE - T2 (220UF 16V)			
C744	nsp	CK73F1H103ZT +1608			
C801	00MOA107025R0	ROA-25V 101M -H4#PE - T2 (100UF 25V)			
C808	nsp	0.1UF 50V +- 5% MTFVA0050J104			
C809	nsp	CK73F1E104ZT +1608			
C810	nsp	0.1UF 50V +- 5% MTFVA0050J104			
C811	nsp	0.1UF 50V +- 5% MTFVA0050J104			
C812	nsp	0.1UF 50V +- 5% MTFVA0050J104			
C813	00MOA476016Z0	ROS-16V 470M - G3#PE - T2 (47UF 16V)			
C814	00MOA107025R0	ROA-25V 101M -H4#PE - T2 (100UF 25V)			
C815	00MOA107025R0	ROA-25V 101M -H4#PE - T2 (100UF 25V)			
C816	nsp	CK73F1E104ZT +1608			
C817	nsp	CK73F1E104ZT +1608			
C818	nsp	1000PF J 100V APSV			
C819	nsp	1000PF J 100V APSV			
C820	nsp	1000PF J 100V APSV			
C821	nsp	1000PF J 100V APSV			
C822	nsp	CK73F1E104ZT +1608			
C823	nsp	CK73F1E104ZT +1608			
C824	nsp	100PF J 100V APSV			
C825	nsp	100PF J 100V APSV			
C826	nsp	1000PF J 100V APSV			
C827	nsp	1000PF J 100V APSV			
C828	nsp	100PF J 100V APSV			
C829	nsp	APSV 221J,220PF(TP) 100V PP			

Ref. No.	Part No.	Part Name	Remarks	Q'ty	New
C830	nsp	APSV 471J,470PF(TP) 100V PP			
C831	nsp	APSV 221J,220PF(TP) 100V PP			
C832	00MOA227016Z0	ROS-16V 221M - H5#PE - T2 (220UF 16V)			
C833	nsp	APSV 221J,220PF(TP) 100V PP			
C834	00MOA227025R0	ROA-25V 221M -H5#PE - T2 (220UF 25V)			
C835	nsp	100PF J 100V APSV			
C836	00MOA227025R0	ROA-25V 221M -H5#PE - T2 (220UF 25V)			
C837	nsp	APSV 471J,470PF(TP) 100V PP			
C838	00MOA227016Z0	ROS-16V 221M - H5#PE - T2 (220UF 16V)			
C839	00MOA227016Z0	ROS-16V 221M - H5#PE - T2 (220UF 16V)			
C840	nsp	APSV 221J,220PF(TP) 100V PP			
C841	00MOA227025R0	ROA-25V 221M -H5#PE - T2 (220UF 25V)			
C842	nsp	CK73F1E104ZT +1608			
C843	00MOA227025R0	ROA-25V 221M -H5#PE - T2 (220UF 25V)			
C844	nsp	CK73F1E104ZT +1608			
C845	00MOA227016Z0	ROS-16V 221M - H5#PE - T2 (220UF 16V)			
C901	00MOA107025R0	ROA-25V 101M -H4#PE - T2 (100UF 25V)			
C908	nsp	0.1UF 50V +- 5% MTFVA0050J104			
C909	nsp	CK73F1E104ZT +1608			
C910	nsp	0.1UF 50V +- 5% MTFVA0050J104			
C911	nsp	0.1UF 50V +- 5% MTFVA0050J104			
C912	nsp	0.1UF 50V +- 5% MTFVA0050J104			
C913	00MOA476016Z0	ROS-16V 470M - G3#PE - T2 (47UF 16V)			
C914	00MOA107025R0	ROA-25V 101M -H4#PE - T2 (100UF 25V)			
C915	00MOA107025R0	ROA-25V 101M -H4#PE - T2 (100UF 25V)			
C916	nsp	CK73F1E104ZT +1608			
C917	nsp	CK73F1E104ZT +1608			
C918	nsp	1000PF J 100V APSV			
C919	nsp	1000PF J 100V APSV			
C920	nsp	1000PF J 100V APSV			
C921	nsp	1000PF J 100V APSV			
C922	nsp	CK73F1E104ZT +1608			
C923	nsp	CK73F1E104ZT +1608			
C924	nsp	100PF J 100V APSV			
C925	nsp	100PF J 100V APSV			
C926	nsp	1000PF J 100V APSV			
C927	nsp	1000PF J 100V APSV			
C928	nsp	100PF J 100V APSV			
C929	nsp	100PF J 100V APSV			
C930	nsp	APSV 471J,470PF(TP) 100V PP			
C931	nsp	APSV 471J,470PF(TP) 100V PP			
C932	00MOA227016Z0	ROS-16V 221M - H5#PE - T2 (220UF 16V)			
C933	00MOA227016Z0	ROS-16V 221M - H5#PE - T2 (220UF 16V)			
C934	00MOA227025R0	ROA-25V 221M -H5#PE - T2 (220UF 25V)			
C935	00MOA227025R0	ROA-25V 221M -H5#PE - T2 (220UF 25V)			
C936	00MOA227025R0	ROA-25V 221M -H5#PE - T2 (220UF 25V)			
C937	00MOA227025R0	ROA-25V 221M -H5#PE - T2 (220UF 25V)			
C938	00MOA227016Z0	ROS-16V 221M - H5#PE - T2 (220UF 16V)			
C939	00MOA227016Z0	ROS-16V 221M - H5#PE - T2 (220UF 16V)			
C940	nsp	APSV 221J,220PF(TP) 100V PP			
C941	nsp	APSV 221J,220PF(TP) 100V PP			
C942	nsp	APSV 221J,220PF(TP) 100V PP			
C943	nsp	CK73F1E104ZT +1608			
C944	nsp	APSV 221J,220PF(TP) 100V PP			
C945	nsp	CK73F1H103ZT +1608			
C946	nsp	CK73F1E104ZT +1608			
C947	nsp	CK73F1E104ZT +1608			

Ref. No.	Part No.	Part Name	Remarks	Q'ty	New
OTHERS PARTS GROUP					
AS101	00D4170476007	RADIATOR			
AS102	447310014008S	RADIATOR(PUE26-25)			
AS103	447310014015S	RADIATOR(PUE26-30)			
CX021	nsp	2P VH CON BASE (White)			
CX022	nsp	2P VH CON BASE (White)			
CX042	nsp	4P CONN.BASE(KR-PH)			
CX151	nsp	15P 160mm PH-SAN			
CX178	nsp	17FMN-BMTTN-TFT			
CX211	nsp	21FMN-BMTTN-A-TFT			
CY032	nsp	3P CONN.BASE(KR-PH)			
CY061	nsp	B6B-EH-TS (LF)(SN) 6P RADIAL TAPING JST			
CY062	nsp	B6B-EH-TS (LF)(SN) 6P RADIAL TAPING JST			
CY063	nsp	6P CONN.BASE(KR-PH)			
CY178	nsp	17FMN-BMTTN-TFT			
CY332	nsp	33P FFC BASE(FMNBMTT +C			
△ F101	00D2061099032	FUSE(0215002.MXP/250V)			
FB401	nsp	E.FIL(BLM21PG221SN1)+2125			
FB402	nsp	E.FIL(BLM21PG221SN1)+2125			
FB403	nsp	E.FIL(BLM21PG221SN1)+2125			
FB404	nsp	E.FIL(BLM21PG221SN1)+2125			
FB405	nsp	E.FIL(BLM21PG221SN1)+2125			
FB601	nsp	BL02RN2-R62T2 FERRITE BEAD			
FB602	nsp	BL02RN2-R62T2 FERRITE BEAD			
FB603	nsp	BL02RN2-R62T2 FERRITE BEAD			
FB604	nsp	BL02RN2-R62T2 FERRITE BEAD			
FB701	nsp	BL02RN2-R62T2 FERRITE BEAD			
FB702	nsp	BL02RN2-R62T2 FERRITE BEAD			
FB703	nsp	BL02RN2-R62T2 FERRITE BEAD			
FB704	nsp	BL02RN2-R62T2 FERRITE BEAD			
FB801	nsp	BL02RN2-R62T2 FERRITE BEAD			
FB802	nsp	BL02RN2-R62T2 FERRITE BEAD			
FB803	nsp	BL02RN2-R62T2 FERRITE BEAD			
FB804	nsp	BL02RN2-R62T2 FERRITE BEAD			
FB901	nsp	BL02RN2-R62T2 FERRITE BEAD			
FB902	nsp	BL02RN2-R62T2 FERRITE BEAD			
FB903	nsp	BL02RN2-R62T2 FERRITE BEAD			
FB904	nsp	BL02RN2-R62T2 FERRITE BEAD			
FF101	nsp	FUSE CLIP(TAPE)			
FH101	nsp	FUSE CLIP(TAPE)			
JK401	00D2048260004	MINI JACK			
JK402	00D2048260004	MINI JACK			
JK403	00D2051305008	9P D-SUB CONNECTOR			
JK601	00MYT02021540	YKC21-4013V RCA 2P AU(BL) FRONT SHIELDED			
JK701	00MYT02021540	YKC21-4013V RCA 2P AU(BL) FRONT SHIELDED			
JK801	00MYT02021540	YKC21-4013V RCA 2P AU(BL) FRONT SHIELDED			
JK901	00MYT02021540	YKC21-4013V RCA 2P AU(BL) FRONT SHIELDED			
L101	00D2390040011	L.FILTER(HR28R-E183)			U
L101	00D2390038078	L.FILTER(HR28R-E333)			N, R, S, K
L102	00D2320201008	COIL(C3B-A0577)			
L103	111810025502S	CHR1048-120M-R			
RL101	00D2140242014	RELAY(DLS5D1-O_M)			

	Ref. No.	Part No.	Part Name	Remarks	Q'ty	New
	RL102	682010007608S	RELAY(DQ12D1-0(M))			
	ST102	nsp	STYLE PIN			
△	T101	102010016007S	SW_TRANS(E3/J ST4282)	U		
△	T101	102010016014S	SW_TRANS(E2 ST4283)	N, R, S, K		
△	T102	101010072004S	POWER TRANS(MINI/E3)	U		
△	T102	101010072011S	POWER TRANS(MINI/E2)	N, R, S, K		
	W101	nsp	GND TERMINAL FOR PCB			
	W102	nsp	GND TERMINAL FOR PCB			
	W103	nsp	GND TERMINAL FOR PCB			
	W104	nsp	GND TERMINAL FOR PCB			
	W106	nsp	GND TERMINAL FOR PCB			
	W107	nsp	GND TERMINAL FOR PCB			
	W405	nsp	M1698-A NEJI TERMINAL			
	W701	nsp	GND TERMINAL FOR PCB			
	W702	nsp	M1698-A NEJI TERMINAL			
	W901	nsp	GND TERMINAL FOR PCB			
	W903	nsp	M1698-A NEJI TERMINAL			
		ORD4700012022	3X12 CPS SW W			
		ORD4700051009	3X8 CPS(SW,W) ZNP			



**8U-210095A AUDIO POWER/VIDEO/Front PWB UNIT ASSY(U model)**  
**8U-210095C AUDIO POWER/VIDEO/Front PWB UNIT ASSY(N, R, S, K model)**

	Ref. No.	Part No.	Part Name	Remarks	Q'ty	New
<b>SEMICONDUCTORS GROUP</b>						
	IC101	00D2623606902	PT6302-R-001(L)			
	IC102	00MHW10004210	RPM6936-V4 (IR SENSOR)			
	IC301	00D2623362903	PCM1796DBR			
	IC302,303	00D2630896909	NJM2068MD-TE1 +C			
△	IC304	00D2631227001	BA50BC0T			
	IC306	00D2630609002	NJM2068DDC +T			
	IC307	00D2630609002	NJM2068DDC +T			
	IC808	236810058609S	ADV7340BSTZ-3			
	IC809	00D2631273903	NJM2566AV			
	IC810	236810058609S	ADV7340BSTZ-3			
	IC811	00D2631282907	BD7820FP-E2			
	IC812	00D2631282907	BD7820FP-E2			
	TR101	00MBA20035210	DTC114EU			
	TR102	00MBA20035210	DTC114EU			
	TR103	00MHT30001000	C2458,C1740S,C3199,ETC.			
	TR104	00MBA10026210	DTA114EU			
	TR105	00MBA10026210	DTA114EU			
	TR301	00MBA20035210	DTC114EU			
	TR302	00MBA20035210	DTC114EU			
	TR303	00MBA10026210	DTA114EU			
	TR304	00MBA10026210	DTA114EU			
	TR305	00MHT600121A0	KTA1268 PNP TRANSISTOR RANK=GR			
	TR306	00MHT600121A0	KTA1268 PNP TRANSISTOR RANK=GR			
	TR307	00MHT800931A0	KTC3200 NPN TRANSISTOR RANK=GR			
	TR308	00MHT800931A0	KTC3200 NPN TRANSISTOR RANK=GR			
	TR309	00MHT800931A0	KTC3200 NPN TRANSISTOR RANK=GR			
	TR310	00MHT800931A0	KTC3200 NPN TRANSISTOR RANK=GR			
	TR311	00MHT600121A0	KTA1268 PNP TRANSISTOR RANK=GR			
	TR312	00MHT600121A0	KTA1268 PNP TRANSISTOR RANK=GR			
	TR313	00MHT600121A0	KTA1268 PNP TRANSISTOR RANK=GR			
	TR314	00MHT600121A0	KTA1268 PNP TRANSISTOR RANK=GR			
	TR315	00MHT800931A0	KTC3200 NPN TRANSISTOR RANK=GR			
	TR316	00MHT800931A0	KTC3200 NPN TRANSISTOR RANK=GR			
	TR317	00MHT600121A0	KTA1268 PNP TRANSISTOR RANK=GR			
	TR318	00MHT600121A0	KTA1268 PNP TRANSISTOR RANK=GR			
	TR319	00MHT800931A0	KTC3200 NPN TRANSISTOR RANK=GR			
	TR320	00MHT800931A0	KTC3200 NPN TRANSISTOR RANK=GR			
	TR321	00MHT800931A0	KTC3200 NPN TRANSISTOR RANK=GR			
	TR322	00MHT800931A0	KTC3200 NPN TRANSISTOR RANK=GR			
	TR323	00MHT600121A0	KTA1268 PNP TRANSISTOR RANK=GR			
	TR324	00MHT600121A0	KTA1268 PNP TRANSISTOR RANK=GR			
	TR325	00D2730460905	KTC2875-B-RTK/P			
	TR326	00D2730460905	KTC2875-B-RTK/P			
	TR327	00D2730460905	KTC2875-B-RTK/P			
	TR328	00D2730460905	KTC2875-B-RTK/P			
	TR331	00MHT30001000	C2458,C1740S,C3199,ETC.			
	TR332	00MHT30001000	C2458,C1740S,C3199,ETC.			
	TR333	00MBA20035210	DTC114EU			
	TR334	00MHT110482B0	2SA1048 Y OR GR TOSHIBA			
	TR335	00MHT600121A0	KTA1268 PNP TRANSISTOR RANK=GR			
	TR336	00MHT800931A0	KTC3200 NPN TRANSISTOR RANK=GR			
△	TR337	00MHT41415100	TRANSISTOR 2SD1415			
△	TR338	00MHT21020100	2SB1020			
	TR339	00MHT800931A0	KTC3200 NPN TRANSISTOR RANK=GR			
	TR340	00MHT600121A0	KTA1268 PNP TRANSISTOR RANK=GR			
	TR822	00D2710293901	2SA1022-B +C			

Ref. No.	Part No.	Part Name	Remarks	Q'ty	New
TR823	00D2710293901	2SA1022-B +C			
TR824	00D2710293901	2SA1022-B +C			
TR826	00D2710293901	2SA1022-B +C			
TR827	00D2710293901	2SA1022-B +C			
D101	00D2760401905	1SS133T77 (TAPE)			
D301	00MHD20002710	1D3 1A/200V			
D302	00MHD20002710	1D3 1A/200V			
D303	00MHD20002710	1D3 1A/200V			
D304	00MHD20003710	! SCHOTTKY 1S100 1A 100V RECTRON			
D305	00MHD20003710	! SCHOTTKY 1S100 1A 100V RECTRON			
D306	00MHD20003710	! SCHOTTKY 1S100 1A 100V RECTRON			
D307	00MHD20003710	! SCHOTTKY 1S100 1A 100V RECTRON			
D308	00MHD20002710	1D3 1A/200V			
D309	00MHD20002710	1D3 1A/200V			
D310	00MHD20003710	! SCHOTTKY 1S100 1A 100V RECTRON			
D311	00MHD20003710	! SCHOTTKY 1S100 1A 100V RECTRON			
D312	00MHD20003710	! SCHOTTKY 1S100 1A 100V RECTRON			
D313	00MHD20003710	! SCHOTTKY 1S100 1A 100V RECTRON			
D314	00D2760401905	1SS133T77 (TAPE)			
D315	00D2760401905	1SS133T77 (TAPE)			
D316	00D2760401905	1SS133T77 (TAPE)			
D317	00D2760401905	1SS133T77 (TAPE)			
D318	00MHD30021010	ZENER HZ6A3L(HITACHI)			
D319	00MHD30021010	ZENER HZ6A3L(HITACHI)			
D320	00MHZ21005000	1SS301 DAN202U UMT TYPE			
D321	00MHZ21005000	1SS301 DAN202U UMT TYPE			
D322	00D2760401905	1SS133T77 (TAPE)			
D323	00D2760401905	1SS133T77 (TAPE)			
D324	00D2760401905	1SS133T77 (TAPE)			
D325	00D2760401905	1SS133T77 (TAPE)			
D801	00D2760794900	KDS160-RTK/P			
D802	00D2760794900	KDS160-RTK/P			
LD101	00MHI10115210	SLR-342VRTB7 RED TAPING			
LD102	00MHI10115210	SLR-342VRTB7 RED TAPING			
LD103	263010032409S	SIR-341STA49			
FL101	00D3938098000	FL TUBE(15-BT-114GNK)			
<b>RESISTORS GROUP</b>					
RE921	00D2472032905	RM73B-750DT(1608)			
RE923	00D2472032905	RM73B-750DT(1608)			
RE925	00D2472032905	RM73B-750DT(1608)			
RE927	00D2472032905	RM73B-750DT(1608)			
RE929	00D2472032905	RM73B-750DT(1608)			
RE931	00D2472032905	RM73B-750DT(1608)			
<b>CAPACITORS GROUP</b>					
C102	nsp	CK73F1H103ZT +1608			
C104	nsp	CC73CH1H101JT +1608			
C105	nsp	CC73CH1H101JT +1608			
C106	nsp	CC73CH1H101JT +1608			
C107	nsp	CK73F1H103ZT +1608			
C108	nsp	CK73F1H103ZT +1608			
C109	nsp	CK73F1H103ZT +1608			
C110	nsp	CK73F1E104ZT +1608			
C111	nsp	CK73F1E104ZT +1608			
C112	nsp	CC73CH1H390JT +1608			

Ref. No.	Part No.	Part Name	Remarks	Q'ty	New
C113	nsp	CK73F1H103ZT +1608			
C114	nsp	CK73F1E104ZT +1608			
C115	nsp	CC73CH1H331JT +1608			
C116	nsp	CK73F1E104ZT +1608			
C117	nsp	CK73F1E104ZT +1608			
C118	nsp	100UF/6.3V			
C119	nsp	100UF/6.3V			
C120	nsp	CK73F1H103ZT +1608			
C301	00MOA107025R0	ROA-25V 101M -H4#PE - T2 (100UF 25V)			
C308	nsp	0.1UF 50V +- 5% MTFVA0050J104			
C309	nsp	CK73F1E104ZT +1608			
C310	nsp	0.1UF 50V +- 5% MTFVA0050J104			
C311	nsp	0.1UF 50V +- 5% MTFVA0050J104			
C312	nsp	0.1UF 50V +- 5% MTFVA0050J104			
△ C313	00MOA33801620	3300UF 16V RA2 TYPE			
C314	nsp	CK73B1H102KT +1608			
C315	nsp	CK73F1E104ZT +1608			
C316	nsp	CK73F1E104ZT +1608			
C317	nsp	0.1UF 50V +- 5% MTFVA0050J104			
C318	00MOA476016Z0	ROS-16V 470M - G3#PE - T2 (47UF 16V)			
C319	00MOA476016Z0	ROS-16V 470M - G3#PE - T2 (47UF 16V)			
C320	00MOA107025R0	ROA-25V 101M -H4#PE - T2 (100UF 25V)			
C321	00MOA107025R0	ROA-25V 101M -H4#PE - T2 (100UF 25V)			
C322	nsp	0.1UF 50V +- 5% MTFVA0050J104			
C323	nsp	1000PF J 100V APSV			
C324	nsp	1000PF J 100V APSV			
C325	nsp	1000PF J 100V APSV			
C326	nsp	1000PF J 100V APSV			
C327	nsp	0.1UF 50V +- 5% MTFVA0050J104			
C328	nsp	0.1UF 50V +- 5% MTFVA0050J104			
C329	nsp	CK73B1H102KT +1608			
C330	nsp	RM73B-0R0KT +1608			
C331	nsp	RM73B-0R0KT +1608			
C335	nsp	100PF J 100V APSV			
C336	nsp	100PF J 100V APSV			
C337	nsp	1000PF J 100V APSV			
C338	nsp	1000PF J 100V APSV			
C339	00MOA22801620	2200UF 16V			
C340	nsp	100PF J 100V APSV			
C341	nsp	APSV 221J,220PF(TP) 100V PP			
C342	nsp	APSV 471J,470PF(TP) 100V PP			
C343	nsp	APSV 221J,220PF(TP) 100V PP			
C344	00MOA227016Z0	ROS-16V 221M - H5#PE - T2 (220UF 16V)			
C345	nsp	470UF 16V M RA-2			
C346	00MOA227025R0	ROA-25V 221M -H5#PE - T2 (220UF 25V)			
C347	00MOA227016R0	ROA-16V 221M -H4#PE - T2 (220UF 16V)			
△ C348	00MOB33802570	3300U 25V(ALP) (LF)-BLOCK CAP			
△ C349	00MOB33802570	3300U 25V(ALP) (LF)-BLOCK CAP			
C350	00MOA106025R0	ROA-25V 100M - E3#PE - T2 (10UF 25V)			
C351	00MOA106025R0	ROA-25V 100M - E3#PE - T2 (10UF 25V)			
C352	00MOA227016R0	ROA-16V 221M -H4#PE - T2 (220UF 16V)			
C353	00MOA227016R0	ROA-16V 221M -H4#PE - T2 (220UF 16V)			
C354	nsp	APSV 221J,220PF(TP) 100V PP			
C355	nsp	APSV 221J,220PF(TP) 100V PP			
C356	00MOA227025R0	ROA-25V 221M -H5#PE - T2 (220UF 25V)			
C357	nsp	CK73F1E104ZT +1608			
C358	00MOA227016Z0	ROS-16V 221M - H5#PE - T2 (220UF 16V)			
C359	nsp	CK73F1E104ZT +1608			
C360	nsp	CK73F1E104ZT +1608			
C361	nsp	100PF J 100V APSV			
C362	nsp	CK73F1E104ZT +1608			

Ref. No.	Part No.	Part Name	Remarks	Q'ty	New
C363	nsp	APSV 471J,470PF(TP) 100V PP			
C365	00MOA227016Z0	ROS-16V 221M - H5#PE - T2 (220UF 16V)			
C367	00MOA227025R0	ROA-25V 221M -H5#PE - T2 (220UF 25V)			
C369	00MOA227025R0	ROA-25V 221M -H5#PE - T2 (220UF 25V)			
C371	00MOA227016Z0	ROS-16V 221M - H5#PE - T2 (220UF 16V)			
C574	nsp	CK73F1E104ZT +1608			
C575	00D2572019909	CS77B0J470MT(NOJ)			
C576	nsp	CK73F1E104ZT +1608			
CC240	00D2570038908	CK73B1A106KT +2125			
CC241	nsp	CK73B1E103KT(1005)			
CC242	nsp	CK73B1H102KT +1005			
CC243	nsp	CK73B1H102KT +1005			
CC244	nsp	CK73B1A104KT +1005			
CC245	00D2570038908	CK73B1A106KT +2125			
CC246	nsp	CK73B1E103KT(1005)			
CC249	00D2570038908	CK73B1A106KT +2125			
CC250	nsp	CK73B1H102KT +1005			
CC251	nsp	CK73B1A104KT +1005			
CC252	nsp	CK73B1A104KT +1005			
CC254	nsp	CK73B1H123KT +1608			
CC255	nsp	CK73B1A104KT +1005			
CC256	nsp	CK73B1A154KT +1608			
CC257	nsp	CK73B1H102KT +1005			
CC258	nsp	CK73B1A104KT +1005			
CC259	nsp	CK73B1H102KT +1005			
CC260	00D2570038908	CK73B1A106KT +2125			
CC261	nsp	CK73B1A104KT +1005			
CC262	nsp	CK73B1E103KT(1005)			
CC263	nsp	CK73B1E103KT(1005)			
CC264	nsp	CK73B1E103KT(1005)			
CC265	00D2570038908	CK73B1A106KT +2125			
CC266	nsp	CK73B1E103KT(1005)			
CC267	nsp	CK73B1A104KT +1005			
CC268	nsp	CK73B1H102KT +1005			
CC269	nsp	CK73B1H123KT +1608			
CC270	nsp	CK73B1A154KT +1608			
CC271	nsp	CK73B1H102KT +1005			
CC272	nsp	CK73B1A104KT +1005			
CC273	nsp	CK73B1A104KT +1005			
CC274	00D2570038908	CK73B1A106KT +2125			
CC275	nsp	CK73B1A104KT +1005			
CC276	nsp	CK73B1H102KT +1005			
CC277	nsp	CK73B1H102KT +1005			
CC278	nsp	CK73B1A104KT +1005			
CC279	nsp	CK73B1E103KT(1005)			
CC283	nsp	CK73B1A104KT +1005			
CC284	nsp	CK73B1A104KT +1005			
CC285	nsp	CK73B1A104KT +1005			
CC288	00D2570525903	CK73B0J475KT(P) +1608			
CC289	nsp	CK73B1H102KT +1005			
CC290	00D2572018900	CS77B1A100MT(NOJ)			
CC291	00D2572018900	CS77B1A100MT(NOJ)			
CC292	nsp	CK73B1A104KT +1005			
CC801	00D2570038908	CK73B1A106KT +2125			
CC802	nsp	CK73B1E103KT(1005)			
CC803	nsp	CK73B1H102KT +1005			
CC804	nsp	CK73B1H102KT +1005			
CC805	nsp	CK73B1A104KT +1005			
CC806	00D2570038908	CK73B1A106KT +2125			
CC807	nsp	CK73B1E103KT(1005)			

Ref. No.	Part No.	Part Name	Remarks	Q'ty	New
CC811	nsp	CK73B1H123KT +1608			
CC812	nsp	CK73B1A154KT +1608			
CC814	nsp	CK73B1A104KT +1005			
CC815	nsp	CK73B1H102KT +1005			
CC816	00D2570038908	CK73B1A106KT +2125			
CC817	nsp	CK73B1E103KT(1005)			
CC818	nsp	CK73B1E103KT(1005)			
CC819	nsp	CK73B1E103KT(1005)			
CC820	nsp	CK73B1E103KT(1005)			
CC821	nsp	CK73B1A104KT +1005			
CC822	nsp	CK73B1H123KT +1608			
CC823	nsp	CK73B1A154KT +1608			
CC824	00D2570038908	CK73B1A106KT +2125			
CC825	nsp	CK73B1A104KT +1005			
CC826	nsp	CK73B1H102KT +1005			
CC829	nsp	CK73B1A104KT +1005			
CC830	nsp	CK73B1A104KT +1005			
CC831	00D2570525903	CK73B0J475KT(P) +1608			
CC832	nsp	CK73B1A104KT +1005			
CC833	00D2572018900	CS77B1A100MT(NOJ)			
CC834	00D2572018900	CS77B1A100MT(NOJ)			
CC835	nsp	CK73B1A104KT +1005			
CC850	nsp	CK73B1A104KT +1005			
CC851	00D2570038908	CK73B1A106KT +2125			
CC852	00D2570038908	CK73B1A106KT +2125			
CC853	00D2570038908	CK73B1A106KT +2125			
CC854	00D2570038908	CK73B1A106KT +2125			
CC856	00D2572018900	CS77B1A100MT(NOJ)			
CC857	nsp	CK73B1A104KT +1005			
CC858	nsp	CK73B1E103KT(1005)			
CC859	nsp	CK73B1A104KT +1005			
CC860	nsp	CK73B1A104KT +1005			
CC861	nsp	CK73B1A104KT +1005			
CC862	nsp	CK73B1A104KT +1005			
CC863	nsp	CK73B1A104KT +1005			
CC975	00D2544533950	CE04W0J471MT SMG/RE3			
CC980	00D2544533950	CE04W0J471MT SMG/RE3			
CC982	00D2544533950	CE04W0J471MT SMG/RE3			
CC984	00D2544533950	CE04W0J471MT SMG/RE3			
CC986	00D2544533950	CE04W0J471MT SMG/RE3			
<b>OTHERS PARTS GROUP</b>					
AS301	nsp	HEAT SINK			
AS302	nsp	SCREW			
AS303	nsp	HEAT SINK			
AS304	nsp	HEAT SINK			
AS305	nsp	SCREW			
AS306	nsp	SCREW			
CX033	nsp	S3B-PH-K-S (LF)(SN)			
CX041	nsp	B4B-EH-TS (LF)(SN) 4P RADIAL TAPING			
CX061	nsp	B6B-EH-TS (LF)(SN) 6P RADIAL TAPING JST			
CX062	nsp	B6B-EH-TS (LF)(SN) 6P RADIAL TAPING JST			
CX131	644810105502S	SD CARD SLOT DM1AA SF PEJ(82)			
CX155	nsp	15P FFC BASE SIDE(P=0.5MM)			
CX183	nsp	18FMN-BTK			
CX211	nsp	21FMN-BMTTN-A-TFT			
CX505	nsp	50FY-BMT-TB(LF)(SN)			
CY022	nsp	CONNECTOR 2P B3P-VH			

	Ref. No.	Part No.	Part Name	Remarks	Q'ty	New
	CY031	nsp	B3B-PH-K-S (LF)(SN)			
	CY033	nsp	B3B-PH-K-S (LF)(SN)			
	CY041	nsp	B4B-EH-TS (LF)(SN) 4P RADIAL TAPING			
	CY042	nsp	4P CONN.BASE(KR-PH)			
	CY241	nsp	24FMN-BMTTN-A-TFT			
	CY331	nsp	33P FFC BASE(FMNBMTT +C			
△	F301	00MFS20050200	# T500MA/250V TR5 NO.19372(TP)			
△	F302	00MFS20050200	# T500MA/250V TR5 NO.19372(TP)			
△	F303	00MFS20100200	# FUSE 1A 250V SEMKO VDE			
△	F304	00MFS20100200	# FUSE 1A 250V SEMKO VDE			
	FB301	nsp	BL02RN2-R62T2 FERRITE BEAD			
	FB302	nsp	BL02RN2-R62T2 FERRITE BEAD			
	FB303	nsp	BL02RN2-R62T2 FERRITE BEAD			
	FB304	nsp	BL02RN2-R62T2 FERRITE BEAD			
	FB305	nsp	BL02RN2-R62T2 FERRITE BEAD			
	FB802	nsp	FBMJ1608HS280NT +1608			
	FB803	nsp	FBMJ1608HS280NT +1608			
	FB804	nsp	FBMJ1608HS280NT +1608			
	FB805	nsp	FBMJ1608HS280NT +1608			
	FB811	nsp	FBMJ1608HS280NT +1608			
	FB812	nsp	FBMJ1608HS280NT +1608			
	FB813	nsp	FBMJ1608HS280NT +1608			
	FB814	nsp	FBMJ1608HS280NT +1608			
	FB889	nsp	FBMJ1608HS280NT +1608			
	FB899	nsp	FBMJ1608HS280NT +1608			
	JK101	00MYT02020890	YKC21-3046V 2P RCA PIN JACK			
	JK301	00MYT02011000	1P RCA PIN JACK T6782-AAAB			
	JK302	00MYT02011000	1P RCA PIN JACK T6782-AAAB			
	JK901	00D2048728009	1P PIN JACK(BK)-LF			
	JK902	00D2048728009	1P PIN JACK(BK)-LF			
	JK903	00D2048728009	1P PIN JACK(BK)-LF			
	JK904	00D2048728009	1P PIN JACK(BK)-LF			
	JK905	00D2051395005	1P S-TERMINAL-LF			
	L803	00D2350125905	INDUCTOR(FLC32C220K)+3216			
	L806	00D2350125905	INDUCTOR(FLC32C220K)+3216			
	L901	00D2350125905	INDUCTOR(FLC32C220K)+3216			
	S101	00MSP01013370	EVQ11L05R H/5MM 160GF			
	S102	00MSP01013370	EVQ11L05R H/5MM 160GF			
	S103	00MSP01013370	EVQ11L05R H/5MM 160GF			
	S104	00MSP01013370	EVQ11L05R H/5MM 160GF			
	S105	00MSP01013370	EVQ11L05R H/5MM 160GF			
	S106	00MSP01013370	EVQ11L05R H/5MM 160GF			
	S107	00MSP01013370	EVQ11L05R H/5MM 160GF			
	S108	00MSP01013370	EVQ11L05R H/5MM 160GF			
	S109	00MSP01013370	EVQ11L05R H/5MM 160GF			
	S110	00MSP01013370	EVQ11L05R H/5MM 160GF			
	S111	00MSP01013370	EVQ11L05R H/5MM 160GF			
	S112	00MSS01020930	SSSF112-S06N1			
△	T305	101010077009M	# POWER TRANSFORMER AC120V EI48-23	U		*
△	T305	101010075003M	# POWER TRANSFORMER AC230V EI48-23	N, S, K, R		*
	W301	nsp	M1698-A NEJI TERMINAL			
	W302	nsp	GND TERMINAL FOR PCB			
	W506	nsp	M3 SCREW TERMINAL			
	W508	nsp	M3 SCREW TERMINAL			

Ref. No.	Part No.	Part Name	Remarks	Q'ty	New
W913	nsp	M1698-A NEJI TERMINAL			
100-B 202-L	471510027005M nsp	BUFFER IR UD9004 37AK RUBBER SHEET			
RS301	00D2473010900	RM73B--472JT+1005			
RS303	00D2473001906	RM73B--0R0KT+1005			
RS304	00D2473001906	RM73B--0R0KT+1005			
RS305	00D2473001906	RM73B--0R0KT+1005			
RS306	00D2472042937	RM73B--153DT(1608)			
RS307	00D2472036943	RM73B--273DT(1608)			
RS308	00D2472036956	RM73B--303DT(1608)			
RS309	00D2473010984	RM73B--103JT +1005			
RS312	00D2473007926	RM73B--331JT			
RS313	nsp	RM73B--0R0KT +1608			
RS314	nsp	RM73B--0R0KT +1608			
RS315	nsp	RM73B--0R0KT +1608			
RS316	nsp	RM73B--0R0KT +1608			
RS317	nsp	RM73B--0R0KT +1608			
RS318	nsp	RM73B--0R0KT +1608			
RS319	nsp	RM73B--0R0KT +1608			
RS320	nsp	RM73B--0R0KT +1608			
RS321	nsp	RM73B--0R0KT +1608			
RS322	nsp	RM73B--0R0KT +1608			
RS324	00D2473007926	RM73B--331JT			
RS326	nsp	RM73B--0R0KT +1608			
RS327	00D2473010900	RM73B--472JT+1005			
RS328	00D2472034903	RM73B--511DT(1608)			
RS331	00D2473001906	RM73B--0R0KT+1005			
RS332	00D2473001906	RM73B--0R0KT+1005			
RS333	00D2473001906	RM73B--0R0KT+1005			
RS334	00D2473001906	RM73B--0R0KT+1005			
RS335	00D2473001906	RM73B--0R0KT+1005			
RS336	00D2473001906	RM73B--0R0KT+1005			
RS338	00D2472036914	RM73B--203DT(1608)			
RS339	00D2472037968	RM73B--823DT(1608)			
RS340	00D2473007926	RM73B--331JT			
RS342	00D2472036956	RM73B--303DT(1608)			
RS343	00D2472005987	RM73B--221JT +1608			
RS344	00D2472005987	RM73B--221JT +1608			
RS345	00D2472005987	RM73B--221JT +1608			
RS346	00D2473007926	RM73B--331JT			
RS347	nsp	RM73B--0R0KT +1608			
RS348	00D2472032905	RM73B--750DT(1608)			
RS349	nsp	RM73B--0R0KT +1608			
RS350	00D2472032905	RM73B--750DT(1608)			
RS351	nsp	RM73B--0R0KT +1608			
RS352	00D2472032905	RM73B--750DT(1608)			
RS353	00D2472032905	RM73B--750DT(1608)			
RS354	00D2472032905	RM73B--750DT(1608)			
RS355	00D2472032905	RM73B--750DT(1608)			
RS356	00D2472003989	RM73B--330JT +1608			
RS357	00D2472003989	RM73B--330JT +1608			
RS358	00D2472003989	RM73B--330JT +1608			
RS359	00D2472007985	RM73B--152JT +1608			
RS360	00D2472007985	RM73B--152JT +1608			
RS361	00D2472007985	RM73B--152JT +1608			
RS365	nsp	RM73B--0R0KT +1608			
RS366	nsp	RM73B--0R0KT +1608			
RS367	nsp	RM73B--0R0KT +1608			
RS370	00D2473001906	RM73B--0R0KT+1005			

Ref. No.	Part No.	Part Name	Remarks	Q'ty	New
RS371	00D2473001906	RM73B-0R0KT+1005			
RS372	00D2473001906	RM73B-0R0KT+1005			
RS401	00D2473001906	RM73B-0R0KT+1005			
RS402	00D2473001906	RM73B-0R0KT+1005			
RS404	00D2473010900	RM73B-472JT+1005			
RS406	00D2473001906	RM73B-0R0KT+1005			
RS407	00D2473001906	RM73B-0R0KT+1005			
RS408	00D2473001906	RM73B-0R0KT+1005			
RS409	00D2473001906	RM73B-0R0KT+1005			
RS412	00D2473007926	RM73B-331JT			
RS413	nsp	RM73B-0R0KT +1608			
RS414	nsp	RM73B-0R0KT +1608			
RS415	nsp	RM73B-0R0KT +1608			
RS416	nsp	RM73B-0R0KT +1608			
RS417	nsp	RM73B-0R0KT +1608			
RS418	nsp	RM73B-0R0KT +1608			
RS419	nsp	RM73B-0R0KT +1608			
RS420	nsp	RM73B-0R0KT +1608			
RS421	nsp	RM73B-0R0KT +1608			
RS422	nsp	RM73B-0R0KT +1608			
RS423	00D2473007926	RM73B-331JT			
RS425	00D2472041925	RM73B-472DT(1608)			
RS426	nsp	RM73B-0R0KT +1608			
RS427	00D2472036969	RM73B-333DT(1608)			
RS428	00D2472006973	RM73B-511JT +1608			
RS431	00D2473006985	RM73B-221JT +1005			
RS432	00D2473006985	RM73B-221JT +1005			
RS433	00D2473006985	RM73B-221JT +1005			
RS434	00D2472005987	RM73B-221JT +1608			
RS435	00D2473001906	RM73B-0R0KT+1005			
RS436	00D2473001906	RM73B-0R0KT+1005			
RS438	00D2473007926	RM73B-331JT			
RS439	00D2473007926	RM73B-331JT			
RS440	nsp	RM73B-0R0KT +1608			
RS441	00D2472033946	RM73B-301DT(1608)			
RS442	nsp	RM73B-0R0KT +1608			
RS443	00D2472033946	RM73B-301DT(1608)			
RS446	00D2472003989	RM73B-330JT +1608			
RS447	00D2472003989	RM73B-330JT +1608			
RS448	00D2472007985	RM73B-152JT +1608			
RS449	00D2472007985	RM73B-152JT +1608			
RS452	nsp	RM73B-0R0KT +1608			
RS453	nsp	RM73B-0R0KT +1608			
RS457	00D2473001906	RM73B-0R0KT+1005			
RS458	00D2473001906	RM73B-0R0KT+1005			



**8U-310041AY MAIN PWB UNIT ASSY(U model)**  
**8U-310041CY MAIN PWB UNIT ASSY(N model)**  
**8U-310041DY MAIN PWB UNIT ASSY(R model)**  
**8U-310041EY MAIN PWB UNIT ASSY(S model)**  
**8U-310041FY MAIN PWB UNIT ASSY(K model)**

Ref. No.	Part No.	Part Name	Remarks	Q'ty	New
<b>SEMICONDUCTORS GROUP</b>					
IC101	nsp	R8A34019BG			
IC102-105	nsp	K4T1G084QQ-HCE6			
IC106	231810080502S	BD3531F-FE2			
IC107,108	nsp	K4T51163QG-HCE6			
IC109	231810080502S	BD3531F-FE2			
IC110	nsp	BE ROM SUB ASSY(UD8004) (S29GL01GP11TFCR20#)			*
IC112	00D2623272909	SN74LVC1G08DBV +C			
IC158	246810031601S	W9825G6EH-6J			
IC159	nsp	WEB CONTROL ROM ASSY(UD8004) (NAND01GW3B2CN6E)			*
IC201	00D2623595903	SN74LV594APWR			
IC202,203	00D2623436907	TC74VHC244FT			
IC204	00D2623595903	SN74LV594APWR			
IC205	231810079502S	MP2209DL-LF-Z			
IC206-208	231810078509S	MP2208DL-LF-Z			
IC209	231810079502S	MP2209DL-LF-Z			
IC351	nsp	EP3C16F256C8N			
IC352	00D2622977917	BA25BC0FP-E2			
IC354	00D2623326907	EPCS4SI8			
IC502	00D2623719006	SII9134CTU			
IC551	246810009604S	W9864G2GH-6			
IC552	245010023605S	ADSP21367KSWZ2A1179			
IC553	nsp	DSP ROM SUB ASSY (W19B160BBT7H)			
IC601	233810001505S	PCA9539PW,188			
IC652	00D2623449004	LC89057W-VF4A			
IC656	0RD2690244009	GP1FAV55TK0F			
IC702	231810079502S	MP2209DL-LF-Z			
IC703	231810050501D	BD18KA5FP-E2			
IC704-706	nsp	BU7331EKN-E2			
IC707	236810028509S	SN74LVC04APW-EL2			
IC709,710	00D2623277904	SN74LVC157APW-EL2 +C			
IC711	231810080502S	BD3531F-FE2			
IC714	236010048501D	SN74LVC74APWR			
IC715	239010021505S	SM8707HV-G-E2			
IC718	239010019502D	BU2365FV-E2			
IC719	239010020502D	SM5158AM-G-E2			
IC751	nsp	EPM570F256C5N			
IC800	nsp	DM860			
IC851	00D2623082924	BD4730G-TR			
IC852	nsp	S-24CS08AFJ-TB +C			
IC853	8R2411002800M	SYSTEM ROM SUB ASSY(UD8004) (R5F364VDNFB)			*
IC854,855	00D2623277904	SN74LVC157APW-EL2 +C			
IC901	nsp	LAN9313-NZW			
IC902	103810002508S	PULSE-TRANS(S558-5999-U-7-F)			
IC905	103810002508S	PULSE-TRANS(S558-5999-U-7-F)			
IC920	nsp	LAN8700-AEZG-TR			
IC921	00D2631240907	BA33B00FP-E2			
IC944,945	nsp	K4T51163QG-HCE7			
IC951	nsp	ABT2015			

**NOTE :**  
 When update Firmware, please confirm a last version in SDI. Use the service board after updating it.

Ref. No.	Part No.	Part Name	Remarks	Q'ty	New
TR551	00D2690192902	KRC102S-RTK/P (10K-10K)			
TR552	00D2690184907	KRA102S-RTK/P (10K-10K)			
TR555	00D2690192902	KRC102S-RTK/P (10K-10K)			
TR651	00D2730487904	2SC2412K_T146R			
TR851	00D2690054901	DTC144EKT96 +C			
TR852	00D2720160901	2SB1132T100Q +C			
TR853	00D2750109903	2SK3019-TL			
TR854,855	00D2690082902	DTC114EKT96 +C			
TR856	00D2690054901	DTC144EKT96 +C			
TR857	00D2720160901	2SB1132T100Q +C			
TR858	00D2690184907	KRA102S-RTK/P (10K-10K)			
TR859	00D2690192902	KRC102S-RTK/P (10K-10K)			
TR860	00D2690184907	KRA102S-RTK/P (10K-10K)			
D504-508	00D2760833900	ESD PROTECTOR(6802)			
D509-516	251210003505S	AVRL161A1R1NTB			
D701	00D2760717903	1SS355 TE-17 +C			
D801	00D2760750902	RB521S-30TE61 +REF			
D851,852	00D2760717903	1SS355 TE-17 +C			
D906	00D2760717903	1SS355 TE-17 +C			
ZD501	00D2760683930	UDZS5.1B-TE17 +C			
<b>RESISTORS GROUP</b>					
R104-107	129250013504S	RM73B-820FT(1005)			
R160-163	129250013504S	RM73B-820FT(1005)			
R203-206	129250013504S	RM73B-820FT(1005)			
R540	129350038519S	RM73B-9532FT(1608)			
R546	129350038502S	RM73B-4993FT(1608)			
R550	129350038502S	RM73B-4993FT(1608)			
R552	00D2472040926	RM73B-105DT(1608)			
R583	129350038502S	RM73B-4993FT(1608)			
R587	129350038502S	RM73B-4993FT(1608)			
R588	129350038540S	RM73B-1583FT(1608)			
R590	129350038526S	RM73B-4023FT(1608)			
R593	129350038502S	RM73B-4993FT(1608)			
R597	129350038533S	RM73B-1334FT(1608)			
R765	129250020502S	RM73B-823FT(1005)			
R783	129250018509S	RM73B-274FT(1005)			
R914	00D2472028906	RM73B-302FT +1608			
RE165	00D2472035957	RM73B-222DT(1608)			
RE166	00D2472031977	RM73B-510DT(1608)			
RE250	00D2472033959	RM73B-331DT(1608)			
RE251	00D2472035960	RM73B-272DT(1608)			
RE254-257	00D2472019902	RM73B-102FT +1608			
RE281,282	00D2472019902	RM73B-102FT +1608			
RE285,286	00D2472019902	RM73B-102FT +1608			
RR165	119210004529S	MMZ1005D121C			
RR189	119210004529S	MMZ1005D121C			
RR334	119210004529S	MMZ1005D121C			
RR336	119210004529S	MMZ1005D121C			
RR711	129350038564S	RM73B-2004FT(1608)			
RR713	129350038502S	RM73B-4993FT(1608)			
RA150-154	126210001597S	MNR04=220(1005X4)			

Ref. No.	Part No.	Part Name	Remarks	Q'ty	New
RA155-160	126210003524S	MNR04=750(1005X4)			
RA200-205	126210001597S	MNR04=220(1005X4)			
RA206-211	126210003524S	MNR04=750(1005X4)			
RA250-253	00D2479007917	MNR14=103JE0 +C			
RA300-303	126210009515S	MNR04=223(1005X4)			
RA400-405	126210001504S	MNR04=000(1005X4)			
RA415-420	126210003593S	MNR04=151(1005X4)			
RA501-509	126210003593S	MNR04=151(1005X4)			
RA510-516	00D2479009902	MNR04=330(1005x4)			
R706	00D2472018903	RM73B--0R0KT +1608/	U, S		
R707	00D2472018903	RM73B--0R0KT +1608/	U		
R709	00D2472006902	RM73B--331JT (1608) +1608/	N		
R709	00D2472006915	RM73B--271JT +1608/	K, R		
R710	00D2472005945	RM73B--151JT +1608/	N		
R710	00D2472004962	RM73B--680JT +1608/	R		
R710	00D2472006902	RM73B--331JT (1608) +1608/	S		
R710	00D2472005961	RM73B--181JT +1608/	K		
R712	00D2472018903	RM73B--0R0KT +1608/	N, K, R		
R713	00D2472018903	RM73B--0R0KT +1608/	N, K, R, S		
R714	00D2472018903	RM73B--0R0KT +1608/	N		
R714	00D2472006902	RM73B--331JT (1608) +1608/	K, R		
R716	00D2472018903	RM73B--0R0KT +1608/	N		
R716	00D2472006915	RM73B--271JT +1608/	S		
R716	00D2472007998	RM73B--162JT +1608/	R		
R716	00D2472008942	RM73B--272JT +1608/	K		
<b>CAPACITORS GROUP</b>					
C101-122	00D2575009974	CK73F1C104ZT +1005			
C123	nsp	CK73B1E103KT(1005)			
C124	00D2575009974	CK73F1C104ZT +1005			
C125-127	nsp	CK73B1E103KT(1005)			
C128-130	00D2575009974	CK73F1C104ZT +1005			
C131-133	nsp	CK73B1E103KT(1005)			
C134-141	00D2575009974	CK73F1C104ZT +1005			
C150-165	00D2575009974	CK73F1C104ZT +1005			
C166	00D2572019909	CS77B0J470MT(NOJ)			
C167-170	00D2575009974	CK73F1C104ZT +1005			
C171	00D2572019909	CS77B0J470MT(NOJ)			
C172-194	00D2575009974	CK73F1C104ZT +1005			
C200-211	00D2575009974	CK73F1C104ZT +1005			
C212	00D2572019909	CS77B0J470MT(NOJ)			
C213	00D2575009974	CK73F1C104ZT +1005			
C214	00D2572019909	CS77B0J470MT(NOJ)			
C215-236	00D2575009974	CK73F1C104ZT +1005			
C250	00D2575009974	CK73F1C104ZT +1005			
C252	00D2570039910	CK73B0J226MT			
C253,254	00D2575009974	CK73F1C104ZT +1005			
C255	00D2570039910	CK73B0J226MT			
C260-263	00D2575009974	CK73F1C104ZT +1005			
C270	nsp	CK73F1E104ZT +1608			
C271	nsp	CK73F1H103ZT +1608			
C272	00D2574012933	CE67C1C101MT (RV2) +REF			
C273,274	00D2570525903	CK73B0J475KT(P) +1608			
C275	nsp	CK73F1E104ZT +1608			
C276	nsp	CK73F1H103ZT +1608			
C277	nsp	CK73B1H102KT +1608			

Ref. No.	Part No.	Part Name	Remarks	Q'ty	New
C278,279	00D2570039910	CK73B0J226MT			
C280	nsp	CK73F1H103ZT +1608			
C281	132350030504S	CK73B1C225KT 1608			
C282	nsp	CK73F1E104ZT +1608			
C283	nsp	GRM32EB31C476KE15L			
C284	nsp	CK73F1H103ZT +1608			
C285	nsp	CK73B1H102KT +1608			
C286,287	00D2570525903	CK73B0J475KT(P) +1608			
C288	nsp	CK73F1E104ZT +1608			
C289	nsp	CK73F1H103ZT +1608			
C290	nsp	CK73B1H102KT +1608			
C291,292	00D2570039910	CK73B0J226MT			
C293,294	nsp	CK73F1H103ZT +1608			
C295	nsp	CK73B1H102KT +1608			
C296,297	nsp	CK73F1E104ZT +1608			
C298	00D2570039910	CK73B0J226MT			
C299	nsp	CK73F1H103ZT +1608			
C300,301	00D2570039910	CK73B0J226MT			
C302	nsp	CK73F1E104ZT +1608			
C303	00D2570039910	CK73B0J226MT			
C304	132350030504S	CK73B1C225KT 1608			
C305	nsp	CK73B1H103KT (1608) +1608			
C306	132350030504S	CK73B1C225KT 1608			
C307	nsp	CK73F1H103ZT +1608			
C308	nsp	CK73B1E223KT +1608			
C309	132350030504S	CK73B1C225KT 1608			
C310	nsp	GRM32EB31C476KE15L			
C311	132350030504S	CK73B1C225KT 1608			
C312	nsp	CK73F1E104ZT +1608			
C313	nsp	GRM32EB31C476KE15L			
C314	nsp	CK73F1H103ZT +1608			
C315,316	nsp	CK73B1H102KT +1608			
C317	nsp	CK73F1H103ZT +1608			
C318	nsp	CK73F1E104ZT +1608			
C319	nsp	GRM32EB31C476KE15L			
C320	nsp	CK73F1E104ZT +1608			
C321-323	00D2570039910	CK73B0J226MT			
C324	nsp	CK73F1E104ZT +1608			
C325,326	00D2570039910	CK73B0J226MT			
C327	nsp	CK73F1E104ZT +1608			
C328,329	00D2570525903	CK73B0J475KT(P) +1608			
C330	nsp	CK73B1E103KT(1005)			
C338-340	nsp	CK73F1E104ZT +1608			
C341	nsp	CK73F1H103ZT +1608			
C342	nsp	CK73B1H102KT +1608			
C343,344	nsp	GRM32EB31C476KE15L			
C345	nsp	CK73F1H103ZT +1608			
C346	nsp	CK73F1E104ZT +1608			
C347	nsp	CK73F1H103ZT +1608			
C348	nsp	GRM32EB31C476KE15L			
C349-354	nsp	CK73F1E104ZT +1608			
C355-359	00D2570513902	CK73F1A105ZT +1608			
C360,361	nsp	CK73F1H103ZT +1608			
C362,363	nsp	CK73F1E104ZT +1608			
C364,365	132350030504S	CK73B1C225KT 1608			
C366-369	nsp	CK73F1E104ZT +1608			
C370,371	132350030504S	CK73B1C225KT 1608			
C402	00D2575009974	CK73F1C104ZT +1005			

Ref. No.	Part No.	Part Name	Remarks	Q'ty	New
C403	00D2544655906	CE67C0J220MT (RV2) +REF			
C405	00D2575009974	CK73F1C104ZT +1005			
C406	00D2570039910	CK73B0J226MT			
C407	00D2575009974	CK73F1C104ZT +1005			
C408	00D2570039910	CK73B0J226MT			
C409	00D2575009974	CK73F1C104ZT +1005			
C411,412	00D2575009974	CK73F1C104ZT +1005			
C413,414	00D2575003909	CC73CH1H220JT +1005			
C415,416	00D2575002900	CC73CH1H8R0DT +1005			
C417,418	00D2575009974	CK73F1C104ZT +1005			
C420	00D2575009974	CK73F1C104ZT +1005			
C421	00D2570039910	CK73B0J226MT			
C422	00D2575009974	CK73F1C104ZT +1005			
C423	00D2571020915	CK73B1H225KT			
C424	00D2575009974	CK73F1C104ZT +1005			
C425	00D2572018900	CS77B1A100MT(NOJ)			
C426	00D2575009974	CK73F1C104ZT +1005			
C427	00D2572018900	CS77B1A100MT(NOJ)			
C429	nsp	CC73CH1H101JT +1005			
C431,432	00D2575002926	CC73CH1H100DT +1005			
C433,434	00D2575002900	CC73CH1H8R0DT +1005			
C435	00D2575009974	CK73F1C104ZT +1005			
C436	00D2572018900	CS77B1A100MT(NOJ)			
C437	nsp	CK73B1H102KT +1005			
C451-457	00D2575006951	CK73B1H471KT +1005			
C458	00D2570038908	CK73B1A106KT +2125			
C459	00D2575006951	CK73B1H471KT +1005			
C460	00D2570038908	CK73B1A106KT +2125			
C461	00D2575006951	CK73B1H471KT +1005			
C464	00D2570038908	CK73B1A106KT +2125			
C465	00D2575006951	CK73B1H471KT +1005			
C466	00D2570038908	CK73B1A106KT +2125			
C467	00D2575006951	CK73B1H471KT +1005			
C472-478	00D2575009974	CK73F1C104ZT +1005			
C503	00D2575009974	CK73F1C104ZT +1005			
C504	nsp	CK73B1H102KT +1005			
C505	00D2575009974	CK73F1C104ZT +1005			
C506	00D2572018900	CS77B1A100MT(NOJ)			
C518	00D2575009974	CK73F1C104ZT +1005			
C519	nsp	CK73B1E103KT(1005)			
C520	00D2570525903	CK73B0J475KT(P) +1608			
C526	nsp	CK73B1H332KT +1608			
C529	nsp	CK73B1E103KT(1005)			
C531	nsp	CK73B1E103KT(1005)			
C532	00D2575009974	CK73F1C104ZT +1005			
C534	00D2575009974	CK73F1C104ZT +1005			
C535-537	00D2570039910	CK73B0J226MT			
C538	00D2575009974	CK73F1C104ZT +1005			
C539	00D2570039910	CK73B0J226MT			
C540	nsp	CK73B1E103KT(1005)			
C542	nsp	CK73B1E103KT(1005)			
C543	00D2570039910	CK73B0J226MT			
C544	00D2570513902	CK73F1A105ZT +1608			
C545,546	00D2575009974	CK73F1C104ZT +1005			
C547,548	00D2570525903	CK73B0J475KT(P) +1608			
C549	132350030504S	CK73B1C225KT 1608			
C552	nsp	GRM32EB31C476KE15L			
C606	00D2575009974	CK73F1C104ZT +1005			

Ref. No.	Part No.	Part Name	Remarks	Q'ty	New
C607	nsp	CK73B1H102KT +1005			
C608	00D2575009974	CK73F1C104ZT +1005			
C609	nsp	CK73B1H102KT +1005			
C610	00D2575009974	CK73F1C104ZT +1005			
C611	nsp	CK73B1H102KT +1005			
C612	00D2575009974	CK73F1C104ZT +1005			
C615	00D2575009974	CK73F1C104ZT +1005			
C616	nsp	CK73B1H102KT +1005			
C617	00D2575009974	CK73F1C104ZT +1005			
C618	nsp	CK73B1H102KT +1005			
C619	00D2570038908	CK73B1A106KT +2125			
C620	00D2570039910	CK73B0J226MT			
C621-641	00D2575009974	CK73F1C104ZT +1005			
C643	nsp	CK73B1E103KT(1005)			
C644	nsp	CK73B1H102KT +1005			
C645	00D2570038908	CK73B1A106KT +2125			
C646	00D2570039910	CK73B0J226MT			
C647-649	00D2575009974	CK73F1C104ZT +1005			
C650	00D2570038908	CK73B1A106KT +2125			
C651	00D2570039910	CK73B0J226MT			
C652-675	00D2575009974	CK73F1C104ZT +1005			
C678-680	00D2575009974	CK73F1C104ZT +1005			
C712,713	00D2570038908	CK73B1A106KT +2125			
C714-722	00D2575009974	CK73F1C104ZT +1005			
C723,724	00D2571500901	CK73D0J476MT(3225)			
C725,726	00D2575009974	CK73F1C104ZT +1005			
C727	nsp	CK73B1E103KT(1005)			
C728	00D2570039910	CK73B0J226MT			
C729-743	00D2575009974	CK73F1C104ZT +1005			
C744	00D2575003983	CC73CH1H470JT			
C745	00D2575009974	CK73F1C104ZT +1005			
C746	nsp	CK73B1E103KT(1005)			
C747	00D2575009974	CK73F1C104ZT +1005			
C748	00D2570038908	CK73B1A106KT +2125			
C749-757	00D2575009974	CK73F1C104ZT +1005			
C758-762	nsp	CK73B1A104KT +1005			
C763-766	00D2575009974	CK73F1C104ZT +1005			
C767	00D2575003983	CC73CH1H470JT			
C768	00D2575009974	CK73F1C104ZT +1005			
C769	00D2570038908	CK73B1A106KT +2125			
C770	nsp	CK73B1A104KT +1005			
C771,772	00D2575009974	CK73F1C104ZT +1005			
C773,774	nsp	CK73B1A104KT +1005			
C775-785	00D2575009974	CK73F1C104ZT +1005			
C786	00D2570039910	CK73B0J226MT			
C801,802	nsp	CK73B1H102KT +1005			
C803-805	00D2575009974	CK73F1C104ZT +1005			
C806-812	nsp	CK73B1H102KT +1005			
C813-817	00D2575009974	CK73F1C104ZT +1005			
C818	nsp	CK73B1H102KT +1005			
C819,820	00D2575009974	CK73F1C104ZT +1005			
C823	nsp	CK73B1H102KT +1005			
C824	00D2575009974	CK73F1C104ZT +1005			
C827-830	nsp	CK73B1H102KT +1005			
C831-834	00D2575009974	CK73F1C104ZT +1005			
C835-842	00D2570525903	CK73B0J475KT(P) +1608			
C847	00D2575009974	CK73F1C104ZT +1005			
C848	nsp	CK73B1H102KT +1005			

Ref. No.	Part No.	Part Name	Remarks	Q'ty	New
C849 C850	00D2575009974 nsp	CK73F1C104ZT +1005 CK73B1H102KT +1005			
CC113-174 CC209	00D2575009974 00D2575009974	CK73F1C104ZT +1005 CK73F1C104ZT +1005			
CC211,212 CC213-220 CC221-228 CC251,252 CC253,254	00D2570525903 00D2575009974 nsp nsp 132350030504S	CK73B0J475KT(P) +1608 CK73F1C104ZT +1005 CK73B1H102KT +1005 CK73F1E104ZT +1608 CK73B1C225KT 1608			
CC301 CC302 CC303 CC304 CC305	00D2572019909 nsp nsp 00D2575009974 00D2572019909	CS77B0J470MT(NOJ) CK73B1E103KT(1005) CK73B1H102KT +1005 CK73F1C104ZT +1005 CS77B0J470MT(NOJ)			
CC306 CC307 CC308-310 CC311 CC313	nsp 00D2575009974 00D2575003983 00D2572021900 00D2575009974	CK73B1H102KT +1005 CK73F1C104ZT +1005 CC73CH1H470JT CS77B0J101MT(NOJ) CK73F1C104ZT +1005			
CC314 CC315 CC316 CC317 CC319,320	00D2572019909 00D2575009974 00D2572021900 00D2572019909 00D2572018900	CS77B0J470MT(NOJ) CK73F1C104ZT +1005 CS77B0J101MT(NOJ) CS77B0J470MT(NOJ) CS77B1A100MT(NOJ)			
CC321,322 CC323,324 CC325,326 CC327,328 CC329,330	nsp nsp nsp nsp nsp	CK73B1H102KT +1005 CK73B1E103KT(1005) CC73CH1H101JT +1005 CK73B1H102KT +1005 CK73B1E103KT(1005)			
CC331,332 CC334 CC336,337 CC338 CC341	nsp nsp nsp nsp nsp	CC73CH1H101JT +1005 CC73CH1H101JT +1005 CK73B1H102KT +1005 CC73CH1H101JT +1005 CC73CH1H101JT +1005			
CC342 CC345-352 CC353,354 CC355,356 CC357,358	nsp 00D2473001906 00D2575009974 nsp 00D2575009974	CK73B1H102KT +1005 RM73B--0R0KT+1005 CK73F1C104ZT +1005 CK73B1E103KT(1005) CK73F1C104ZT +1005			
CC359,360 CC430 CC431 CC432 CC433	nsp 00D2572018900 nsp 00D2572022909 nsp	CK73B1E103KT(1005) CS77B1A100MT(NOJ) CK73B1E103KT(1005) CS77B0J220MT(NOJ) CK73B1H102KT +1005			
CC434-437 CC438 CC439-450 CC453 CC454	00D2575009974 00D2572019909 00D2575009974 nsp nsp	CK73F1C104ZT +1005 CS77B0J470MT(NOJ) CK73F1C104ZT +1005 CK73B1E103KT(1005) CK73B1H102KT +1005			
CC455 CC456 CC457 CC458 CC459	nsp nsp nsp nsp 00D2575001956	CK73B1E103KT(1005) CK73B1H102KT +1005 CK73B1E103KT(1005) CK73B1H102KT +1005 CC73CH1H3R0CT +1005			
CC460 CC461 CC462-465	00D2575007934 00D2575001956 00D2572022909	CK73B1H222KT +1005 CC73CH1H3R0CT +1005 CS77B0J220MT(NOJ)			

Ref. No.	Part No.	Part Name	Remarks	Q'ty	New
CC466-470 CC471	00D2575009974 00D2572022909	CK73F1C104ZT +1005 CS77B0J220MT(NOJ)			
CC473 CC474 CC475 CC476 CC477	00D2575009974 nsp 00D2570038908 00D2575009974 nsp	CK73F1C104ZT +1005 CK73B1E103KT(1005) CK73B1A106KT +2125 CK73F1C104ZT +1005 CK73B1E103KT(1005)			
CC501-508 CC509-516 CC517-524 CC525 CC527,528	nsp nsp 00D2575009974 00D2572018900 00D2575009974	CC73CH1H101JT +1005 CK73B1H102KT +1005 CK73F1C104ZT +1005 CS77B1A100MT(NOJ) CK73F1C104ZT +1005			
CC530,531 CC532 CC534 CC535 CC538,539	00D2575009974 00D2570525903 00D2575009974 00D2570525903 00D2575001998	CK73F1C104ZT +1005 CK73B0J475KT(P) +1608 CK73F1C104ZT +1005 CK73B0J475KT(P) +1608 CC73CH1H7R0DT +1005			
CC601 CC602,603 CC604 CC605 CC606	00D2570039910 00D2575009974 nsp 00D2575009974 nsp	CK73B0J226MT CK73F1C104ZT +1005 CK73B1E223KT +1608 CK73F1C104ZT +1005 CK73B1E103KT(1005)			
CC607 CC608,609 CC610 CC611,612 CC613-615	nsp 00D2575009974 nsp 00D2575001998 00D2575009974	CK73B1H102KT +1005 CK73F1C104ZT +1005 CK73B1H102KT +1005 CC73CH1H7R0DT +1005 CK73F1C104ZT +1005			
CC616 CC617 CC618 CC626 CC628	nsp nsp 00D2575009974 00D2570038908 00D2570513902	CK73B1E103KT(1005) CK73B1H102KT +1005 CK73F1C104ZT +1005 CK73B1A106KT +2125 CK73F1A105ZT +1608			
CC629 CC701 CC702,703 CC704 CC705-708	nsp 00D2570525903 00D2575002942 00D2570525903 00D2575009974	CK73B1E103KT(1005) CK73B0J475KT(P) +1608 CC73CH1H120JT +1005 CK73B0J475KT(P) +1608 CK73F1C104ZT +1005			
CC709 CC710 CC711 CC712 CC713-715	nsp 00D2575009974 00D2570525903 00D2575009974 00D2570525903	CK73B1E103KT(1005) CK73F1C104ZT +1005 CK73B0J475KT(P) +1608 CK73F1C104ZT +1005 CK73B0J475KT(P) +1608			
CC716-718 CC719 CC720-722 CC723-728 CC729	00D2575009974 00D2570525903 00D2575009974 nsp 00D2570525903	CK73F1C104ZT +1005 CK73B0J475KT(P) +1608 CK73F1C104ZT +1005 CK73B1E103KT(1005) CK73B0J475KT(P) +1608			
CC730 CC735 CC736 CC737,738 CC741	nsp 00D2570525903 nsp 00D2575002968 nsp	CK73B1E103KT(1005) CK73B0J475KT(P) +1608 CK73B1E103KT(1005) CC73CH1H150JT +1005 CK73B1E223KT +1608			
CC742 CC743-749 CC750 CC751 CC752-761	00D2570525903 00D2575009974 nsp 00D2575009974 nsp	CK73B0J475KT(P) +1608 CK73F1C104ZT +1005 CK73B1H102KT +1608 CK73F1C104ZT +1005 CK73B1E103KT(1005)			
CC762	00D2570525903	CK73B0J475KT(P) +1608			



Ref. No.	Part No.	Part Name	Remarks	Q'ty	New
CC763 CC768,769 CC772 CC773	nsp 00D2575002968 00D2570525903 nsp	CK73B1E103KT(1005) CC73CH1H150JT +1005 CK73B0J475KT(P) +1608 CK73B1E103KT(1005)			
CC774 CC903 CC904 CC905,906 CC907	nsp nsp nsp 00D2575002942 00D2570525903	CK73B1E223KT +1608 CK73B1H102KT +1005 CK73B1E103KT(1005) CC73CH1H120JT +1005 CK73B0J475KT(P) +1608			
CC908 CC909 CC910,911 CC912,913 CC914	nsp 00D2570525903 nsp 00D2570525903 nsp	CK73B1E103KT(1005) CK73B0J475KT(P) +1608 CK73B1E103KT(1005) CK73B0J475KT(P) +1608 CK73B1E103KT(1005)			
CC915 CC916-919 CC920 CC921 CC926	00D2570525903 nsp 00D2570525903 nsp 00D2570525903	CK73B0J475KT(P) +1608 CK73B1E103KT(1005) CK73B0J475KT(P) +1608 CK73B1E103KT(1005) CK73B0J475KT(P) +1608			
CC927 CC928,929 CC932 CC933 CC934	nsp 00D2575002968 nsp nsp 00D2575009974	CK73B1E103KT(1005) CC73CH1H150JT +1005 CK73B1E223KT +1608 CK73B1H102KT +1608 CK73F1C104ZT +1005			
CC935 CC937-939 CC950,951 CC952-961 CC962-967	nsp 00D2570038908 nsp 00D2575006951 nsp	CK73B1H102KT +1005 CK73B1A106KT +2125 CK73B1E103KT(1005) CK73B1H471KT +1005 CK73B1H102KT +1005			
CC968 CC969-972 CC973-978	00D2570038908 00D2575009974 nsp	CK73B1A106KT +2125 CK73F1C104ZT +1005 CK73B1E103KT(1005)			
<b>OTHERS PARTS GROUP</b>					
CX031 CX079 CX151 CX241	nsp nsp nsp nsp	3P PH CON.BASE(TAPE) +REF 7P FFC BASE(9610SC) 15P FFC BASE SIDE(P=0.5MM) 24FMN-SMT-A-TF (LF)(SN)			
CX331,332 CX501	nsp nsp	33P FFC BASE(FMNBMTT +C 50FY-BMT-TB(LF)(SN)			
CY151 CY183	00MYJ07061430 nsp	CONN. S15B-PH-SM4-TB (LF)(SN)JST 18P/18FMN-BMTTN-TF			
CY402 CY452	645010043506S 645010044509S	40P-FFC-BASE(HF601) 45P-FFC-BASE(HF601)			
FB101,102 FB104,105	00D2350136907 00D2350136907	FBMJ1608HS280NT +1608 FBMJ1608HS280NT +1608			
FB107 FB108-113 FB301,302 FB351-353 FB401,402	00D2350136907 00D2350147909 00D2350136907 00D2350136907 00D2350130903	FBMJ1608HS280NT +1608 E.FIL(BLM21PG221SN1)+2125 FBMJ1608HS280NT +1608 FBMJ1608HS280NT +1608 CHIP EMIFIL(11A121) +1608			
FB502,503 FB504-509 FB601 FB607	00D2350136907 119310005507S 00D2350136907 119310005507S	FBMJ1608HS280NT +1608 MPZ1608S221A FBMJ1608HS280NT +1608 MPZ1608S221A			

Ref. No.	Part No.	Part Name	Remarks	Q'ty	New
FB609	119310005507S	MPZ1608S221A			
FB701,702	00D2350147909	E.FIL(BLM21PG221SN1)+2125			
FB703,704	00D2350130903	CHIP EMIFIL(11A121) +1608			
FB706,707	00D2350130903	CHIP EMIFIL(11A121) +1608			
FB708	119310005507S	MPZ1608S221A			
FB710	119310005507S	MPZ1608S221A			
FB712	00D2350136907	FBMJ1608HS280NT +1608			
FB801	119310005507S	MPZ1608S221A			
FB851,852	00D2350136907	FBMJ1608HS280NT +1608			
FB888	119310005507S	MPZ1608S221A			
FB901	00D2350136907	FBMJ1608HS280NT +1608			
FB906	00D2350147909	E.FIL(BLM21PG221SN1)+2125			
FB907-914	00D2350136907	FBMJ1608HS280NT +1608			
FB916	00D2350147909	E.FIL(BLM21PG221SN1)+2125			
FB929	00D2350147909	E.FIL(BLM21PG221SN1)+2125			
FB933,934	00D2350147909	E.FIL(BLM21PG221SN1)+2125			
JK101	643010069601S	ETHER-JACK(08B01X1T06-F)			
JK601	00D2048719005	19P HDMI CONNECTOR			
JK651	00D2048728009	1P PIN JACK(BK)-LF			
L100-105	111810021500S	INDUCTOR3.3uH(C6K5LGA)			
L803-808	00D2350125905	INDUCTOR(FLC32C220K)+3216			
W651,652	nsp	M3 SCREW TERMINAL			
X101	nsp	FCX-05(24.000MHz) 15ppm			
X102	nsp	FCX-05(25.000MHz) 10ppm			
X551	nsp	FCX-05(20.815MHz) 15ppm			
X602	nsp	FCX-05(22.5792MHz) 10ppm			
X609	nsp	FCX-05(24.576MHz) 10ppm			
X651	nsp	FCX-05(24.576MHz) 10ppm			
X705	nsp	FCX-05(27.000MHz) 10ppm			
X851	nsp	TFX-02(32.768kHz)			
X852	nsp	FCX-05(20.000MHz) 15ppm			
RS101	119210004529S	MMZ1005D121C			
RS102-104	00D2473001906	RM73B--0R0KT+1005			
RS107-114	00D2473001906	RM73B--0R0KT+1005			
RS117-124	00D2473001906	RM73B--0R0KT+1005			
RS149-168	00D2473004945	RM73B--220JT+1005			
RS169-173	00D2473001906	RM73B--0R0KT+1005			
RS174,175	00D2473006901	RM73B--101JT+1005			
RS176	nsp	RM73B--0R0KT +1608			
RS180	00D2473001906	RM73B--0R0KT+1005			
RS182	00D2473001906	RM73B--0R0KT+1005			
RS184	00D2473001906	RM73B--0R0KT+1005			
RS186	00D2473001906	RM73B--0R0KT+1005			
RS211-213	00D2473004945	RM73B--220JT+1005			
RS215-222	00D2473004945	RM73B--220JT+1005			
RS255-272	00D2473001906	RM73B--0R0KT+1005			
RS273	00D2473010900	RM73B--472JT+1005			
RS276	00D2472007972	RM73B--132JT +1608			
RS277	00D2472007985	RM73B--152JT +1608			
RS278	00D2473001906	RM73B--0R0KT+1005			
RS280	00D2473010900	RM73B--472JT+1005			
RS281,282	00D2473001906	RM73B--0R0KT+1005			
RS283	00D2473006901	RM73B--101JT+1005			

Ref. No.	Part No.	Part Name	Remarks	Q'ty	New
RS284	00D2473008941	RM73B--102JT			
RS285	00D2473012940	RM73B--473JT+1005			
RS286	00D2473001906	RM73B--0R0KT+1005			
RS287,288	00D2473009908	RM73B--182JT			
RS293-295	00D2473001906	RM73B--0R0KT+1005			
RS501,502	00D2473001906	RM73B--0R0KT+1005			
RS503-521	00D2473003962	RM73B--100JT			
RS522	00D2473015963	RM73B--105KT +1005			
RS523-525	00D2473010984	RM73B--103JT +1005			
RS526	00D2473004987	RM73B--330JT +1005			
RS527	00D2473010984	RM73B--103JT +1005			
RS529	00D2473001906	RM73B--0R0KT+1005			
RS531	129350038571S	RM73B--1242FT(1608)			
RS532	00D2473004987	RM73B--330JT +1005			
RS534	00D2473010984	RM73B--103JT +1005			
RS536	00D2473003962	RM73B--100JT			
RS537	00D2473010984	RM73B--103JT +1005			
RS538	00D2473003962	RM73B--100JT			
RS539	129250039506S	RM73B--510FT(1005)			
RS540	00D2473010984	RM73B--103JT +1005			
RS541	00D2473003962	RM73B--100JT			
RS542	129250039506S	RM73B--510FT(1005)			
RS543,544	00D2473010984	RM73B--103JT +1005			
RS545-547	00D2473003962	RM73B--100JT			
RS548	00D2473010984	RM73B--103JT +1005			
RS549	00D2473003962	RM73B--100JT			
RS550	129250039506S	RM73B--510FT(1005)			
RS551	00D2473010984	RM73B--103JT +1005			
RS552	00D2473003962	RM73B--100JT			
RS553	129250039506S	RM73B--510FT(1005)			
RS554-565	00D2473003962	RM73B--100JT			
RS567	00D2473001906	RM73B--0R0KT+1005			
RS568-570	00D2473003962	RM73B--100JT			
RS571-575	00D2473008941	RM73B--102JT			
RS576,577	00D2473005973	RM73B--750JT			
RS578,579	00D2473008941	RM73B--102JT			
RS580,581	00D2473010984	RM73B--103JT +1005			
RS583,584	00D2473010984	RM73B--103JT +1005			
RS585,586	00D2473003962	RM73B--100JT			
RS587-591	00D2473008941	RM73B--102JT			
RS593-605	00D2473008941	RM73B--102JT			
RS606-609	129250039506S	RM73B--510FT(1005)			
RS610	00D2473003962	RM73B--100JT			
RS612	00D2473001906	RM73B--0R0KT+1005			
RS613	nsp	RM73B--0R0KT +1608			
RS615	00D2473010984	RM73B--103JT +1005			
RS616,617	00D2473007971	RM73B--511JT			
RS618	00D2473010984	RM73B--103JT +1005			
RS619,620	00D2473001906	RM73B--0R0KT+1005			
RS700	00D2473010984	RM73B--103JT +1005			
RS701	00D2473008983	RM73B--152JT			
RS702	00D2473005931	RM73B--510JT			
RS703	nsp	RM73B--0R0KT +2125			
RS704	00D2473010984	RM73B--103JT +1005			
RS705	00D2473001906	RM73B--0R0KT+1005			
RS707-710	00D2473003962	RM73B--100JT			
RS711	00D2473010900	RM73B--472JT+1005			
RS712	00D2473003962	RM73B--100JT			

Ref. No.	Part No.	Part Name	Remarks	Q'ty	New
RS713,714	00D2473010984	RM73B-103JT +1005			
RS715,716	00D2473001906	RM73B-0R0KT+1005			
RS717	00D2473010984	RM73B-103JT +1005			
RS718-721	00D2473001906	RM73B-0R0KT+1005			
RS722	00D2473008983	RM73B-152JT			
RS723	00D2473010984	RM73B-103JT +1005			
RS725	00D2473010984	RM73B-103JT +1005			
RS727,728	00D2473010984	RM73B-103JT +1005			
RS729	00D2473011912	RM73B-133JT			
RS730	00D2473015963	RM73B-105KT +1005			
RS731	00D2473010984	RM73B-103JT +1005			
RS732	00D2473010939	RM73B-622JT			
RS733	00D2473010984	RM73B-103JT +1005			
RS735	00D2473009940	RM73B-272JT			
RS738	00D2473008941	RM73B-102JT			
RS742	00D2473010984	RM73B-103JT +1005			
RS744	00D2473010984	RM73B-103JT +1005			
RS745	00D2473008983	RM73B-152JT			
RS746	00D2473010900	RM73B-472JT+1005			
RS747	00D2473010984	RM73B-103JT +1005			
RS749	00D2473008983	RM73B-152JT			
RS750-764	00D2473010984	RM73B-103JT +1005			
RS765-768	00D2473004945	RM73B-220JT+1005			
RS769	129350038571S	RM73B-1242FT(1608)			
RS770-773	129250039506S	RM73B-510FT(1005)			
RS774	00D2473003962	RM73B-100JT			
RS775,776	00D2473005973	RM73B-750JT			
RS777	00D2473005931	RM73B-510JT			
RS778-781	00D2473010900	RM73B-472JT+1005			
RS782-801	00D2473005931	RM73B-510JT			
RS802,803	00D2473010900	RM73B-472JT+1005			
RS804-820	00D2473005931	RM73B-510JT			
RS823,824	nsp	RM73B-0R0KT +1608			
RS827	00D2473001906	RM73B-0R0KT+1005			
RS829	00D2473001906	RM73B-0R0KT+1005			

### 8U-310037A FE/SACD PWB UNIT ASSY

Ref. No.	Part No.	Part Name	Remarks	Q'ty	New
<b>SEMICONDUCTORS GROUP</b>					
IC100	nsp	R8J32801AFPV			
IC106	nsp	AD8062ARMZ-R7			
IC107	nsp	BA6846FV-E2			
IC151	nsp	BD7956FS-E2			
IC301	nsp	BH18MA3WHFV-TR			
IC302	nsp	MM1661ZHBE			
IC303	nsp	MM1687CFBE			
IC304	nsp	MM1825YHBE			
IC305	nsp	BU19502KV-SE2			
IC502	nsp	EM636165TS-7G			
IC503	nsp	CXD2753R +C			
IC504	nsp	SN74LVC04APW-EL2			
IC602	nsp	BA25BC0FP-E2			
IC603	nsp	BA00HC5FP			
IC605	nsp	FPGA ROM ASSY (ES29LV160EB-70TG1)			
IC605	nsp	or FPGA ROM ASSY (W19B160BBT7H)			
IC606	nsp	XC3S500E-4FTG256C			
IC901	nsp	SN74LVC2G04DBVR			
IC902	nsp	SN74CBTLV16210GR			
IC903	nsp	SN74CBTLV16212GR			
IC904	nsp	SN74CBTLV16210GR			
IC961	nsp	BA33DD0WHFP			
D901,902	nsp	1SS355 TE-17 +C			
D903-905	nsp	1SR154-400TE25 +REF			
D906-908	nsp	1SS355 TE-17 +C			
D910,911	nsp	1SS355 TE-17 +C			
TR501	nsp	DTC114EKT96 +C			
TR502	nsp	DTA114EKT96 +C			
TR503	nsp	DTC114EKT96 +C			
TR504	nsp	DTA114EKT96 +C			
<b>RESISTORS GROUP</b>					
R148	nsp	RM73B-0R0KT +1608			
R159	nsp	RM73B-123FT +1608			
R175	nsp	RM73B-101JT+1005			
R186	nsp	RM73B-0R0KT+1005			
R190	nsp	RM73B-0R0KT+1005			
R220	nsp	RM73B-152JT			
R226	nsp	RM73B-623JT+1005			
R228,229	nsp	RM73B-0R0KT+1005			
R232	nsp	RM73B-0R0KT +1608			
R233,234	nsp	RM73B-0R0KT +1608			
R239	nsp	RM73B-623JT+1005			
R250	nsp	RM73B-0R0KT+1005			
R255	nsp	RM73B-332DT(1608)			
R258	nsp	RM73B-101JT+1005			
R294,295	nsp	RM73B-0R0KT+1005			
R304	nsp	RM73B-0R0KT+1005			
R307	nsp	RM73B-0R0KT+1005			

Ref. No.	Part No.	Part Name	Remarks	Q'ty	New
R308	nsp	RM73B-0R0KT+1005			
R313	nsp	RM73B-472JT+1005			
R318	nsp	RM73B-220JT+1005			
R320	nsp	RM73B-123FT +1608			
R321	nsp	RM73B-220JT+1005			
R322	nsp	RM73B-224DT(1608)			
R323	nsp	RM73B-152JT			
R327	nsp	RM73B-220JT+1005			
R348-354	nsp	RM73B-0R0KT+1005			
R355-375	nsp	RM73B-0R0KT+1005			
R401-405	nsp	RM73B-220JT+1005			
R406-413	nsp	RM73B-220JT+1005			
R426	nsp	RM73B-0R0KT+1005			
R428,429	nsp	RM73B-0R0KT+1005			
R430-435	nsp	RM73B-0R0KT+1005			
R439,440	nsp	RM73B-0R0KT+1005			
R452-454	nsp	RM73B-0R0KT+1005			
R456	nsp	RM73B-0R0KT+1005			
R458	nsp	RM73B-0R0KT+1005			
R522-524	nsp	RM73B-0R0KT+1005			
R525-533	nsp	RM73B-0R0KT+1005			
R534-549	nsp	RM73B-0R0KT+1005			
R550R	nsp	RM73B-220JT+1005			
R598,599	nsp	RM73B-0R0KT+1005			
R603-604	nsp	RM73B-220JT+1005			
R606	nsp	RM73B-0R0KT+1005			
R607	nsp	RM73B-472JT+1005			
R610,611	nsp	RM73B-472JT+1005			
R612-615	nsp	RM73B-0R0KT+1005			
R623	nsp	RM73B-472JT+1005			
R626-641	nsp	RM73B-0R0KT+1005			
R642,643	nsp	RM73B-101JT+1005			
R644	nsp	RM73B-472JT+1005			
R646,647	nsp	RM73B-472JT+1005			
R649	nsp	RM73B-472JT+1005			
R653	nsp	RM73B-472JT+1005			
R654	nsp	RM73B-0R0KT+1005			
R657-662	nsp	RM73B-220JT+1005			
R663-671	nsp	RM73B-101JT+1005			
R673-682	nsp	RM73B-101JT+1005			
R683-686	nsp	RM73B-473JT+1005			
R687	nsp	RM73B-220JT+1005			
R688-695	nsp	RM73B-0R0KT+1005			
R696-698	nsp	RM73B-101JT+1005			
R702-706	nsp	RM73B-0R0KT+1005			
R718	nsp	RM73B-220JT+1005			
R720	nsp	RM73B-220JT+1005			
R723-730	nsp	RM73B-220JT+1005			
R750	nsp	RM73B-0R0KT+1005			
R790	nsp	RM73B-0R0KT+1005			
R922-924	nsp	RM73B-0R0KT+1005			
R925R,926	nsp	RM73B-0R0KT+1005			
R927,928	nsp	RM73B-0R0KT +1608			
R935-940	nsp	RM73B-0R0KT+1005			
R942-945	nsp	RM73B-0R0KT+1005			
R948	nsp	RM73B-0R0KT+1005			

Ref. No.	Part No.	Part Name	Remarks	Q'ty	New
R965	nsp	RM73B-0R0KT+1005			
R985	nsp	RM73B-220JT+1005			
R988	nsp	RM73B-220JT+1005			
R990	nsp	RM73B-220JT+1005			
R998	nsp	RM73B-0R0KT+1005			
R999	nsp	RM73B-0R0KT+1005			
RA401,402	nsp	MNR14=220JE0AB +C			
RR104	nsp	RM73B-102JT			
RR105	nsp	RM73B-0R0KT+1005			
RR106-108	nsp	RM73B-102JT			
RR144,145	nsp	RM73B-102JT			
RR150	nsp	RM73B-152JT			
RR905-907	nsp	RM73B-102FT +1608			
RR913	nsp	RM73B-0R0KT+1005			
RR914-916	nsp	RM73B-0R0KT+1005			
RR917	nsp	RM73B2B0R0KT +3216			
<b>CAPACITORS GROUP</b>					
C101	nsp	CK73B1A105KT +1608			
C102	nsp	CE67C1C101MT(MVA)(100/16)			
C103-105	nsp	CK73B1A105KT +1608			
C106,107	nsp	CK73F1H103ZT +1005			
C108-110	nsp	CK73B1E103KT(1005)			
C111	nsp	CK73F1H103ZT +1005			
C112	nsp	CK73B1A106KT +2125			
C113	nsp	CK73F1H103ZT +1005			
C114	nsp	CK73B1A106KT +2125			
C115	nsp	CK73B1A105KT +1608			
C116	nsp	CK73F1C104ZT +1005			
C117,118	nsp	CK73B1A105KT +1608			
C119,120	nsp	GRM188B11H223KA01D			
C121,122	nsp	CK73F1C104ZT +1005			
C123,124	nsp	CK73B1A474KT			
C125	nsp	GRM188B11H223KA01D			
C126	nsp	CK73F1H103ZT +1005			
C127	nsp	CK73F1C104ZT +1005			
C129,130	nsp	CK73F1H103ZT +1005			
C131	nsp	CK73B1H222KT +1608			
C132	nsp	CK73B1E103KT(1005)			
C133	nsp	CC73CH1H471JT +1608			
C134	nsp	CK73F1H103ZT +1005			
C135-138	nsp	CK73B1E683KT(1608) +1608			
C139,140	nsp	CK73B1A104KT +1005			
C141	nsp	CK73F1C104ZT +1005			
C142	nsp	CK73B1A106KT +2125			
C143	nsp	CK73F1H103ZT +1005			
C144	nsp	CC73CH1H331JT +1608			
C145	nsp	CK73B1A106KT +2125			
C146-148	nsp	CC73CH1H471JT +1608			
C149	nsp	CK73B1A104KT +1005			
C150,151	nsp	CK73B1H102KT +1005			
C152	nsp	CC73CH1H471JT +1608			
C153	nsp	CK73B1A104KT +1005			

Ref. No.	Part No.	Part Name	Remarks	Q'ty	New
C154	nsp	CK73B1E103KT(1005)			
C155	nsp	CK73F1H103ZT +1005			
C156-158	nsp	CK73F1C104ZT +1005			
C159	nsp	CK73F1H103ZT +1005			
C160,161	nsp	CK73B1E103KT(1005)			
C162	nsp	CK73F1H103ZT +1005			
C163,164	nsp	CK73F1C104ZT +1005			
C165	nsp	CC73CH1H101JT +1005			
C166	nsp	CK73B1A106KT +2125			
C167-170	nsp	CK73F1C104ZT +1005			
C171,172	nsp	CK73F1H103ZT +1005			
C173	nsp	CK73F1C104ZT +1005			
C176	nsp	CK73F1C104ZT +1005			
C177	nsp	CK73F1C104ZT +1005			
C178	nsp	CK73F1H103ZT +1005			
C179	nsp	CK73F1C104ZT +1005			
C180,181	nsp	CK73F1H103ZT +1005			
C182	nsp	CK73B1E103KT(1005)			
C185-187	nsp	CK73F1H103ZT +1005			
C188,189	nsp	CK73F1C104ZT +1005			
C190	nsp	CK73F1H103ZT +1005			
C191,192	nsp	CK73F1C104ZT +1005			
C193-195	nsp	CK73B1A104KT +1005			
C196,197	nsp	CK73F1C104ZT +1005			
C198	nsp	CK73F1C104ZT +1005			
C199,200	nsp	CK73F1H103ZT +1005			
C201-203	nsp	CK73F1C104ZT +1005			
C204,205	nsp	CC73CH1H7R0DT +1608			
C206,207	nsp	CK73B1E103KT(1005)			
C208	nsp	CK73B1A104KT +1005			
C211,212	nsp	CK73B1E103KT(1005)			
C214	nsp	CE67C1C101MT(MVA)(100/16)			
C215	nsp	CK73F1C104ZT +1005			
C216	nsp	CK73B1H103KT (1608) +1608			
C217	nsp	CE67C0J101MT(MV)(100/6.3)			
C218,219	nsp	CK73F1C104ZT +1005			
C222	nsp	CE67C1C101MT(MVA)(100/16)			
C223	nsp	CK73B1A106KT +2125			
C224	nsp	CK73F1C104ZT +1005			
C230	nsp	CK73F1C104ZT +1005			
C231-234	nsp	CE67C1C220MT(MV)(22/16)			
C235	nsp	CE67C0J101MT(MV)(100/6.3)			
C240	nsp	CK73F1C104ZT +1005			
C301,302	nsp	CE67C0J101MT(MV)(100/6.3)			
C303	nsp	CK73F1C104ZT +1005			
C304	nsp	CK73F1H103ZT +1005			
C308	nsp	CK73F1H103ZT +1005			
C309,310	nsp	CK73B1E103KT(1005)			
C311	nsp	CK73F1H103ZT +1005			
C312,313	nsp	CK73B1E103KT(1005)			
C314	nsp	CK73F1C104ZT +1005			
C315	nsp	CK73F1H103ZT +1005			
C316	nsp	CC73CH1H150JT +1005			
C317	nsp	CC73CH1H180JT +1005			
C318	nsp	CK73F1C104ZT +1005			
C319,320	nsp	CK73F1H103ZT +1005			



Ref. No.	Part No.	Part Name	Remarks	Q'ty	New
C321-323	nsp	CK73F1H103ZT +1005			
C324-326	nsp	CK73F1C104ZT +1005			
C401	nsp	CK73F1C104ZT +1005			
C402	nsp	CE67C0J101MT(MV)(100/6.3)			
C403,404	nsp	CK73F1C104ZT +1005			
C406-411	nsp	CK73F1C104ZT +1005			
C412	nsp	CE67C1C220MT(MV)(22/16)			
C413	nsp	CK73B1H102KT +1005			
C414,415	nsp	CK73F1C104ZT +1005			
C418	nsp	CK73F1C104ZT +1005			
C423-426	nsp	CK73F1C104ZT +1005			
C428	nsp	CK73F1C104ZT +1005			
C429-432	nsp	CK73F1C104ZT +1005			
C433	nsp	CE67C0J101MT(MV)(100/6.3)			
C434	nsp	CK73F1H103ZT +1005			
C435	nsp	CK73F1C104ZT +1005			
C501	nsp	CK73F1C104ZT +1005			
C502	nsp	CC73CH1H102JT +1608			
C503	nsp	CK73F1C104ZT +1005			
C504	nsp	CC73CH1H102JT +1608			
C505	nsp	CK73F1C104ZT +1005			
C506	nsp	CC73CH1H102JT +1608			
C507	nsp	CK73F1C104ZT +1005			
C507	nsp	CK73F1C104ZT +1005			
C508	nsp	CC73CH1H102JT +1608			
C509	nsp	CS77B1A100MT(NOJ)			
C511	nsp	CK73F1C104ZT +1005			
C512	nsp	CC73CH1H102JT +1608			
C513	nsp	CK73F1C104ZT +1005			
C514	nsp	CC73CH1H102JT +1608			
C515	nsp	CK73F1C104ZT +1005			
C516	nsp	CC73CH1H102JT +1608			
C517	nsp	CK73F1C104ZT +1005			
C518	nsp	CC73CH1H102JT +1608			
C519	nsp	CS77B1A100MT(NOJ)			
C520	nsp	CK73F1C104ZT +1005			
C521	nsp	CC73CH1H102JT +1608			
C522	nsp	CK73F1C104ZT +1005			
C523	nsp	CC73CH1H102JT +1608			
C524	nsp	CK73F1C104ZT +1005			
C525	nsp	CC73CH1H102JT +1608			
C526	nsp	CS77B1A100MT(NOJ)			
C528	nsp	CK73F1C104ZT +1005			
C530	nsp	CC73CH1H102JT +1608			
C531	nsp	CS77B1A100MT(NOJ)			
C535	nsp	CK73F1H103ZT +1005			
C536	nsp	CK73F1C104ZT +1005			
C538	nsp	CK73B1H102KT +1005			
C751-753	nsp	CK73F1C104ZT +1005			
C754	nsp	CK73F1H103ZT +1005			
C755	nsp	CK73F1C104ZT +1005			
C756	nsp	CK73F1H103ZT +1005			
C757	nsp	CK73F1C104ZT +1005			
C758	nsp	CK73F1H103ZT +1005			
C759	nsp	CK73F1C104ZT +1005			
C901	nsp	CK73B1A105KT +1608			

Ref. No.	Part No.	Part Name	Remarks	Q'ty	New
C902	nsp	CS77B1A100MT(NOJ)			
C903,904	nsp	CK73B1A105KT +1608			
C905	nsp	CE67C1C220MT(MV)(22/16)			
C906,907	nsp	CK73B1A105KT +1608			
C908,909	nsp	CE67C0J101MT(MV)(100/6.3)			
C910	nsp	CS77B1A100MT(NOJ)			
C911,912	nsp	CE67C0J101MT(MV)(100/6.3)			
C913	nsp	CK73B1A105KT +1608			
C914	nsp	CE67C1C220MT(MV)(22/16)			
C915	nsp	CK73F1C104ZT +1005			
C916	nsp	CK73B1H103KT (1608) +1608			
C917	nsp	CK73F1H103ZT +1005			
C918	nsp	CK73B1A106KT +2125			
C919	nsp	CK73F1C104ZT +1005			
C920	nsp	CK73F1H103ZT +1005			
C921	nsp	CK73B1A106KT +2125			
C922	nsp	CC73CH1H471JT +1608			
C923,924	nsp	CK73F1C104ZT +1005			
C925	nsp	CE67C1C220MT(MV)(22/16)			
C926	nsp	CE67C1C220MT(MV)(22/16)			
C927,928	nsp	CK73B1A106KT +2125			
C929	nsp	GRM188B11H223KA01D			
C930	nsp	CK73F1C104ZT +1005			
C931	nsp	CE67C1C220MT(MV)(22/16)			
C933	nsp	CK73B1A105KT +1608			
C934	nsp	CK73F1C104ZT +1005			
C935	nsp	CE67C1C220MT(MV)(22/16)			
C937	nsp	CE67C1C101MT(MVA)(100/16)			
C938	nsp	CK73F1C104ZT +1005			
C939	nsp	CS77B1A100MT(NOJ)			
C940	nsp	CE67C0J101MT(MV)(100/6.3)			
C941	nsp	CE67C1C101MT(MVA)(100/16)			
C943	nsp	CK73B1A105KT +1608			
C944	nsp	CK73B1A106KT +2125			
C945	nsp	CK73B1H103KT (1608) +1608			
C946,947	nsp	CE67C1C101MT(MVA)(100/16)			
C949	nsp	CK73F1C104ZT +1005			
C950	nsp	CK73B1A106KT +2125			
C951	nsp	CE67C1C101MT(MVA)(100/16)			
C952	nsp	CK73F1C104ZT +1005			
C953	nsp	CE67C1C101MT(MVA)(100/16)			
C954	nsp	CK73F1C104ZT +1005			
C955	nsp	CE67C1C101MT(MVA)(100/16)			
C956	nsp	CK73F1C104ZT +1005			
C957	nsp	CK73B1A106KT +2125			
C958	nsp	CE67C1C220MT(MV)(22/16)			
C960	nsp	CK73B1A106KT +2125			
C962	nsp	CK73B1H104KT +1608			
C963	nsp	CS77B1A100MT(NOJ)			
C964	nsp	CK73B1H104KT +1608			
C969	nsp	CE67C0J101MT(MV)(100/6.3)			
C974	nsp	CK73B1H104KT +1608			
C977	nsp	CK73B1H104KT +1608			
C990	nsp	CK73F1C104ZT +1005			
C995	nsp	CK73B1H104KT +1608			
C998	nsp	CK73B1H104KT +1608			

Ref. No.	Part No.	Part Name	Remarks	Q'ty	New
CC904,905	nsp	CK73B1H104KT +1608			
CC907	nsp	CK73B1H104KT +1608			
CC909	nsp	CK73B1H104KT +1608			
CC913	nsp	CK73B1H104KT +1608			
CC916	nsp	CK73B1H104KT +1608			
CC918	nsp	CK73B1H104KT +1608			
CC920	nsp	CK73B1H104KT +1608			
CC925	nsp	CK73B1H104KT +1608			
CC927	nsp	CK73B1H104KT +1608			
<b>OTHERS PARTS GROUP</b>					
CX053	nsp	5P PH CON.BASE(L) +REF			
CX063	nsp	6P PH CON.BASE(L) +REF			
CX182	nsp	18P-FFC-BASE			
CX402	nsp	40P-FFC-BASE			
CX451,452	nsp	45P-FFC-BASE			
FB101-105	nsp	BLM18PG330SN1			
FB106,107	nsp	RM73B-0R0KT +1608			
FB301,302	nsp	RM73B-0R0KT +1608			
FB901,902	nsp	BLM18PG330SN1			
FB904-908	nsp	BLM18PG330SN1			
FB910-913	nsp	BLM18PG330SN1			
FB914-916	nsp	RM73B-0R0KT +1608			
FB917-919	nsp	BLM18PG330SN1			
FB932	nsp	BLM18PG330SN1			
FB933-936	nsp	RM73B-0R0KT +1608			
FB937	nsp	BLM18PG330SN1			
X100	nsp	DSX321G(33.8688MHz)			
X301	nsp	DSX321G(25.0MHz)			
	nsp	BD MECHA UNIT (TB501SO1)			
	nsp	MECHA BRACKET			
	nsp	3X8 CBTS (S)-B			
	nsp	45P FFC			

--MEMO--

# WIRING DIAGRAM

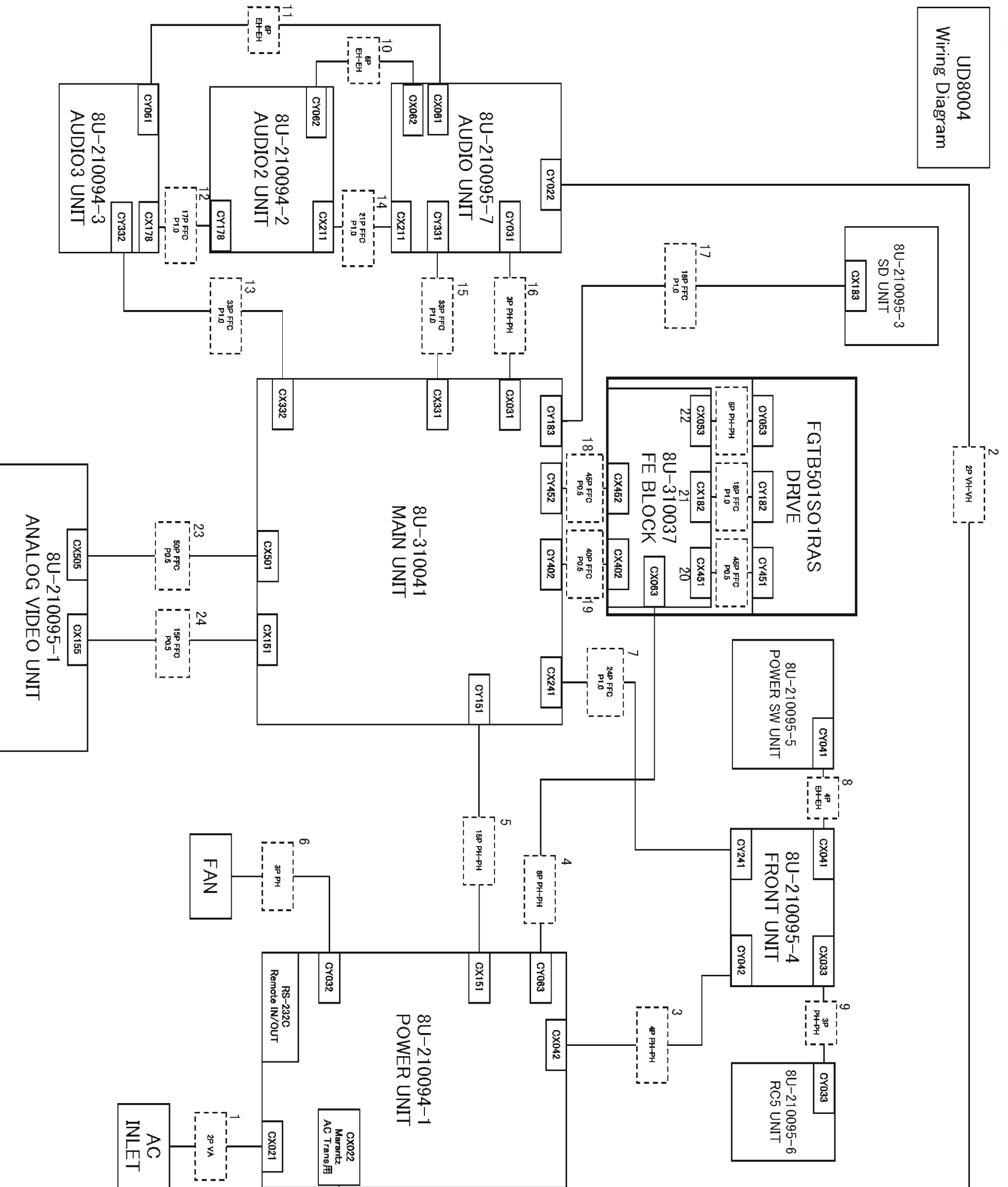

# EXPLODED VIEW

SYMBOL	STYLE	PARTS NAME
⊗	—	+B.H.M.SCREW
⊗	⊗	+B.H.TAP TITE SCREW W/WASHER
⊗	⊗	+PH.TAP TITE SCREW(3 TYPE)
⊗	⊗	+B.H.TAP TITE SCREW(3 TYPE)
⊗	⊗	+B. H. TAP TITE SCREW(W/T. L. WASHER)

MARK	MATERIAL/FINISH
(M)	STEEL/COPPER
(U)	STEEL/BLACK

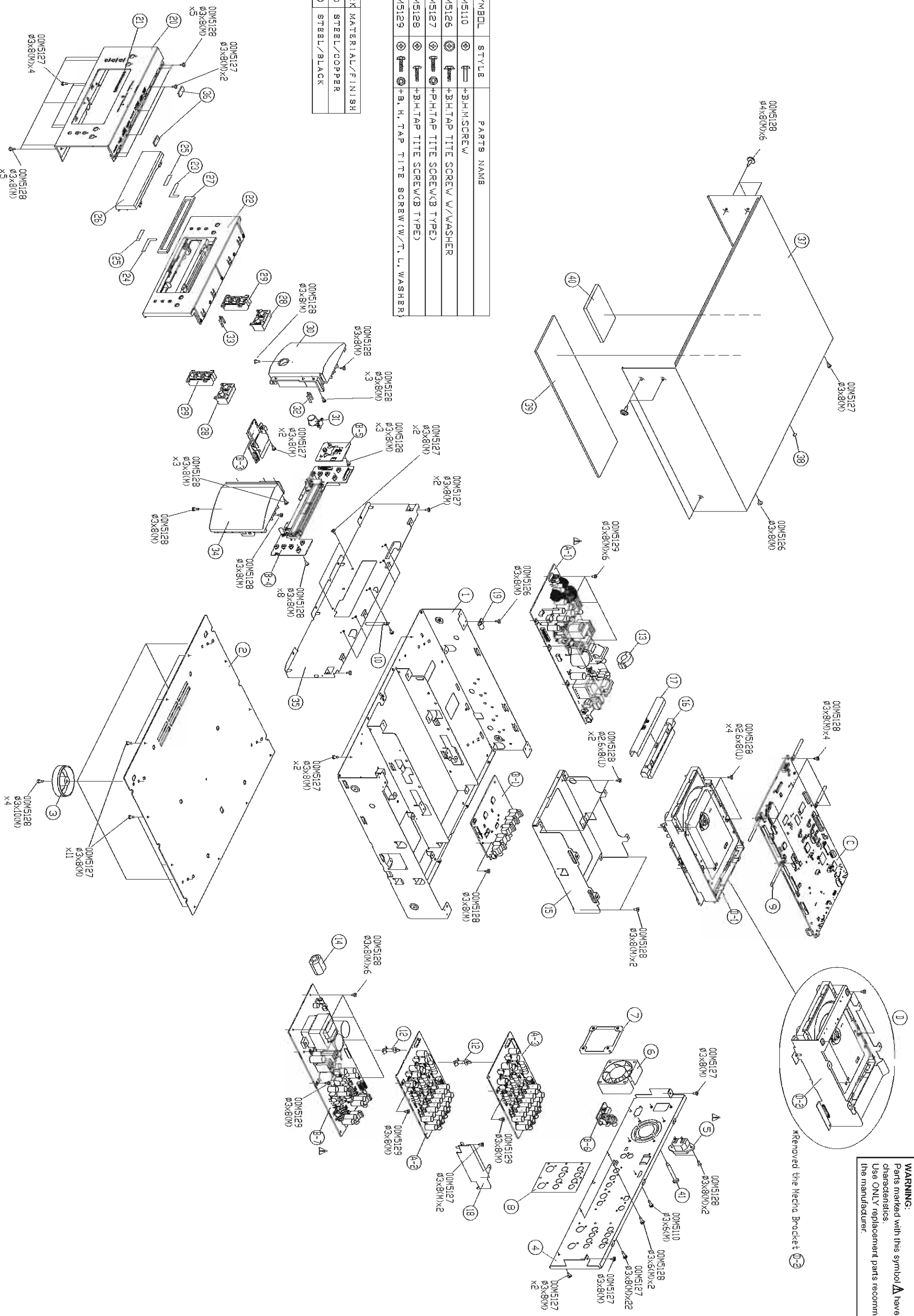

**WARNING:**  
 Parts marked with this symbol **Δ** have critical characteristics.  
 Use **ONLY** replacement parts recommended by the manufacturer.

# PARTS LIST OF EXPLODED VIEW

\* Parts for which "nsp" is indicated on this table cannot be supplied.

\* P.W.B. ASS'Y for which "nsp" is indicated on this table cannot be supplied. When repairing the P.W.B. ASS'Y, check the board parts table and order replacement parts.

\* The parts listed below are for maintenance only, might differ from the parts used in the unit in appearances or dimensions.

Note: The symbols in the column "Remarks" indicate the following destinations.

U : North America model  
S : Singapore model

N : Europe model  
K : China model

R : Russia model

Ref. No.	Part No.	Part Name	Remarks	Q'ty	New																		
△	A	nsp	AUDIO/POWER UNIT		1	*																	
	A-1	-	POWER UNIT																				
	A-2	-	AUDIO-2 PWB UNIT																				
	A-3	-	AUDIO-3 PWB UNIT																				
	B	nsp	AUDIO POWER/VIDEO/FRONT UNIT		1	*																	
	B-1	-	ANALOG VIDEO UNIT																				
	B-3	-	SD UNIT																				
	B-4	-	FRONT UNIT																				
	B-5	-	POWER SW UNIT																				
△	B-6	-	RC UNIT																				
	B-7	-	AUDIO UNIT																				
	C	8U-310041AY	MAIN PWB UNIT(U1B)	U	1	*																	
<p><b>NOTE :</b> We make only 8U-310041AY the service parts. Please change the destination-resistors when changing 8U-310041AY's destination. Please refer to BD REGION and DVD REGION (page 125)</p> <table border="1"> <thead> <tr> <th></th> <th>BD</th> <th>DVD</th> </tr> </thead> <tbody> <tr> <td>U</td> <td>A</td> <td>1</td> </tr> <tr> <td>N</td> <td>B</td> <td>2</td> </tr> <tr> <td>S</td> <td>A</td> <td>3</td> </tr> <tr> <td>K</td> <td>C</td> <td>6</td> </tr> <tr> <td>R</td> <td>C</td> <td>5</td> </tr> </tbody> </table>							BD	DVD	U	A	1	N	B	2	S	A	3	K	C	6	R	C	5
	BD	DVD																					
U	A	1																					
N	B	2																					
S	A	3																					
K	C	6																					
R	C	5																					
	D	FGTB501S01RAS	BD MECHA UNIT(SACD)		1																		
	D-1	-	FE/SACD UNIT (WITH SACD)		1																		
	D-2	-	MECHA BRACKET		1																		
	★ D-3	544010103000D	LASER LABEL(BD)		1																		
	1	nsp	CHASSIS(2930)		1	*																	
	2	nsp	INSIDE PLATE		1																		
	3	00M03AJ057210	LEG		4	*																	
	4	nsp	REAR PANEL UD8004 (U) 38AK	U	1	*																	
△	4	nsp	REAR PANEL UD8004 (K) 38AK	K	1	*																	
	4	nsp	REAR PANEL UD8004 (N) 38AK	N	1	*																	
	4	nsp	REAR PANEL UD8004 (R) 38AK	R	1	*																	
	4	nsp	REAR PANEL UD8004 (S) 38AK	S	1	*																	
	5	00D2033996008	AC INLET (2P)		1																		
	6	nsp	FAN 2410RL04WS19		1																		
	7	nsp	FAN BRACKET		1																		
	8	488410016004M	CONTACTOR REAR PANEL UD8004 38AK		1	*																	
	9	nsp	CORD HOLDER (L50)		4																		
	10	00D4458028009	CORD HOLDER		5																		
	★ 11	nsp	WIRE CLAMPER		5																		
	12	00M194J101010	SUPPORT KGLS-18S		2																		
	13	nsp	FERRITE CORE TFC-23-11-14		1																		
	14	nsp	FERRITE CLAMP(RFC-6W)		1																		
	15	nsp	MECHA BRACKET UD8004 38AK		1	*																	

	Ref. No.	Part No.	Part Name	Remarks	Q'ty	New
	16	418510018000M	TRAY ESCUTCHEON INNER BL UD8004 38AK		1	*
	17	418410017008M	TRAY ESCUTCHEON BL UD8004 38AK		1	*
	18	nsp	BRACKET PWB AUDIO UD8004 38AK		1	*
	19	nsp	CLAMPER		1	
	20	402410097009M	FRONT AL PANEL BL UD8004 38AK		1	*
	21	421410006004M	MARANTZ BADGE (AL) FOR M1 MODEL		1	
	22	nsp	FRONT MOLD CHASSIS BL UD8004 38AK		1	*
	23	nsp	SHEET EMC UD8004 38AK		1	*
	24	nsp	SHEET EMC UD8004 38AK R		1	*
	25	nsp	LABEL MASK UD8004 38AK		2	*
	26	416510041004M	WINDOW UD8004 38AK		1	*
	27	nsp	BUFFER TRAY FRONT UD8004 38AK		1	*
	28	411510112000M	BUTTON PLAY/EJECT BL UD8004 38AK		2	*
	29	411510113003M	BUTTON SCAN/P.DIRECT BL UD8004 38AK		2	*
	30	402510095002M	ESCUTCHEON L BL UD8004 38AK		1	*
	31	411510021005M	BUTTON BL		1	
	32	481510003006M	LENS		1	
	33	481510003006M	LENS		1	
	34	402510096005M	ESCUTCHEON R BL UD8004 38AK		1	*
	35	nsp	FRONT CHASSIS UD8004 38AK		1	*
	36	nsp	BUFFER		2	
	37	403310039014M	TOP COVER BL UD8004 38AK		1	*
	38	nsp	MASK TOP LID REAR		1	
	39	nsp	RUBBER FORM		1	
	40	nsp	DAMPER		1	*
	41	nsp	4X35 CPTS(S)-B		4	
	★ 42	nsp	EMIGASKET RFSG060100		-	
	★ 43	nsp	LABEL LICENCE UD8004 38AK		1	*
<b>WIRES</b>						
	★ 301	nsp	SMCD-17X70-BDX8(BL)-P1.0-S4M		1	
	★ 302	nsp	SMCD-21X70-BDX6(BL)-P1.0-S4-M		1	
	★ 303	nsp	SMCD-33X70-BDX6(BL)-P1.0-S4		1	
	★ 304	606050052015S	FFC 50P 110mm 0.5mm AD		1	
	★ 305	606050054011S	FFC 18P 190mm 1.0mm BD		1	
	★ 306	606050054028S	FFC 24P 250mm 1.0mm BD		1	
	★ 307	606050054035S	FFC 33P 140mm 1.0mm BD		1	
	★ 308	606050098004S	FFC 40P 100mm 0.5mm BD		1	
	★ 309	606050098011S	FFC 45P 100mm 0.5mm BD		1	
△	★ 310	606050100006S	FFC 15P 116mm 0.5mm AD		1	
	★ 311	nsp	2P 170mm VA		1	
	★ 312	nsp	6P 100mm PH-PH		1	
	★ 313	nsp	PHR-3 130MM UL1430 AWG24		1	*
	★ 314	nsp	EHR-4 60MM UL1007 AWG28		1	*
	★ 315	nsp	PHR-3 410MM UL1007 AWG28		1	*
	★ 316	nsp	EHR-6 90MM UL1430 AWG24		1	*
	★ 317	nsp	VAR2 800MM UL1672 AWG18		1	*
	★ 318	nsp	EHR-6 120MM UL1430 AWG24		1	*
	★ 319	nsp	PHR-4 150MM UL1007 AWG28		1	*



# PACKING VIEW

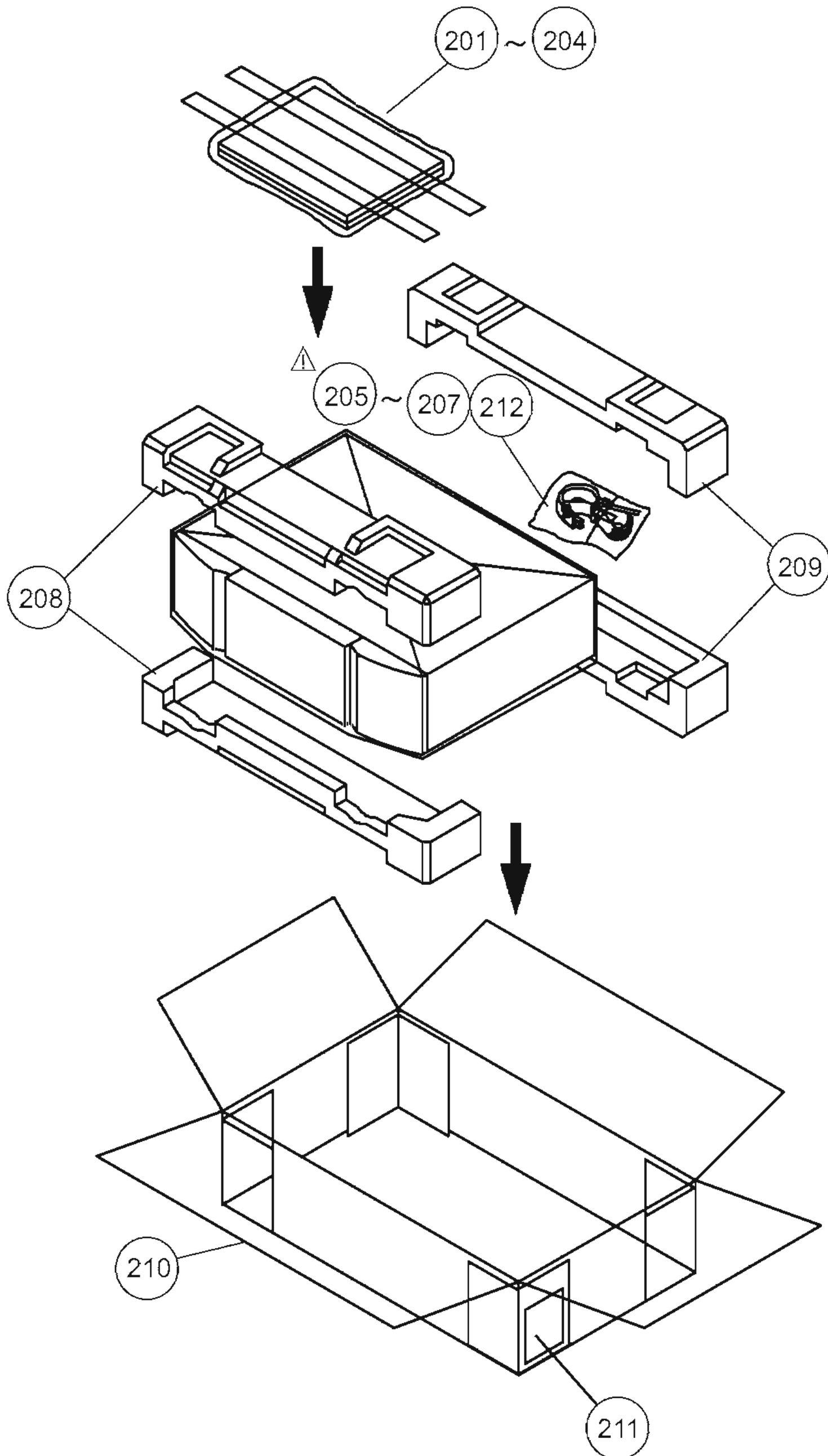

# PARTS LIST OF PACKING & ACCESSORIES

\* Parts for which "nsp" is indicated on this table cannot be supplied.

\* The parts listed below are for maintenance only, might differ from the parts used in the unit in appearances or dimensions.

Note: The symbols in the column "Remarks" indicate the following destinations.

U : North America model

N : Europe model

R : Russia model

S : Singapore model

K : Chaina model

	Ref. No.	Part No.	Part Name	Remarks	Q'ty	New
	201	541110396024M	USER MANUAL UD8004 (U) 38AK	U	1	*
	201	541110396055M	USER MANUAL UD8004 (K) 38AK	K	1	*
	201	541110396031M	USER MANUAL UD8004 (N.S) 38AK	N, R, S	1	*
	202	nsp	WARRANTY USA	U	1	
	202	nsp	WARRANTY CANADA	U	1	
	203	nsp	BATTERY(R03X2)		1	
	★ 203-1	nsp	BATTERY LABEL (E2)	N, S	1	
	204	307010064009M	RC004UD REMOCON UNIT C.G.DEVELOPMENT		1	*
△	205	00MZC01802100	# AC CORDSET 125V13A UL/CSA	U	1	
△	205	00MZC01803080	# 2P AC CORD 10A 250V CLASS2	N, R, S	1	
	205	00D2062249001	AC CORD (E1C)	K	1	
	206	nsp	2P PIN CORD		1	
	207	nsp	1P PIN CORD(VIDEO)		1	
	208	533610045108M	CUSHION F UD9004 37AK		1	
	209	533610046101M	CUSHION R UD9004 37AK		1	
	210	531210127053M	PACKING CASE UD8004 38AK		1	*
	211	nsp	SHIPPING LABEL SEETE		2	
	212	nsp	TWIN SHIELDED WIRE WITH RCA PLUGS		1	
	★ 213	nsp	SHEET (AF+PE)		1	
	★ 214	nsp	POLY COVER		1	
	★ 215	nsp	CLEAR LABEL(66X27 T0.05)	U	1	
	★ 216	nsp	GOST FLY SHEET UD8004 38AK	R	1	
	★ 216	nsp	GOST FLY SHEET UD8004 38AK	R	1	

## MEASURING METHOD AND WAVEFORMS

Measuring Disc: CD/TCD-784  
DVD/VT502 or TDV-520A  
BD/ABD-520 or BLX-108

To check the waveforms on the FE/SACD UNIT, the GND (-) probe to "⑰VC" point.

① - ⑱ points have the certain test points shown below.

- The HF waveform (ATEST) is not normally output. The waveform can be output by setting the test mode. Cancel the test mode to play a disc. For details, see "7. Test mode" (page 21-28).  
Other signals are output.
- When HF waveform (ATEST) is noisy or cannot discriminate the eye-pattern, replace the Travers Unit after measuring the IOP.
  - ※When watching the HF waveform (ATEST), use the extending wire as short as possible.
  - ※It is better to use wires for extending between the probe and test points.
  - ※There is no test point at "⑰VC". Please use the point on the + side of C217.

### 1. MAIN UNIT : TEST POINT AND WAVEFORMS

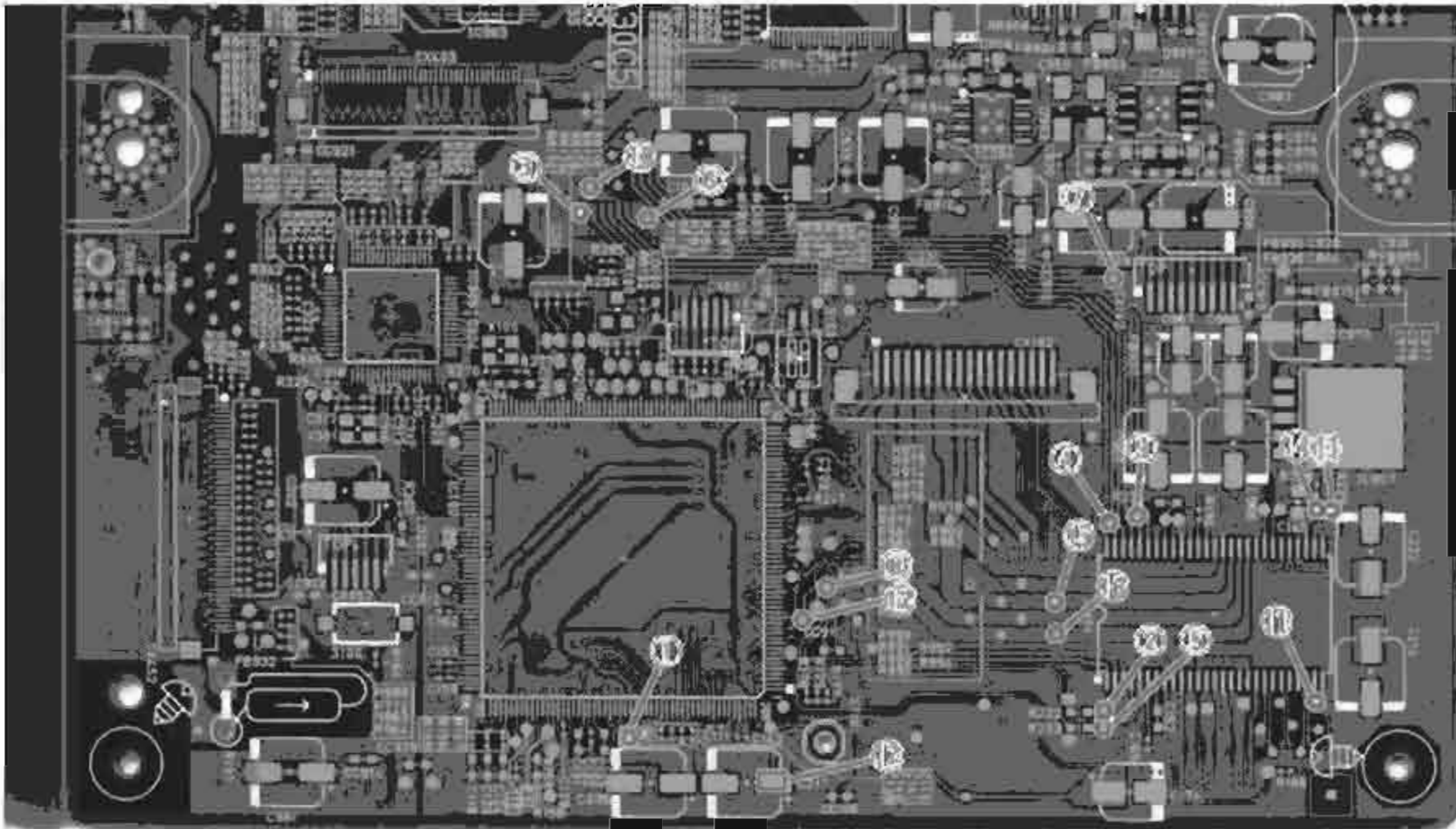

8U-310037 FE/SACE UNIT : Component Side

# BD PLAY Disc : ABD-520

## HF wave form

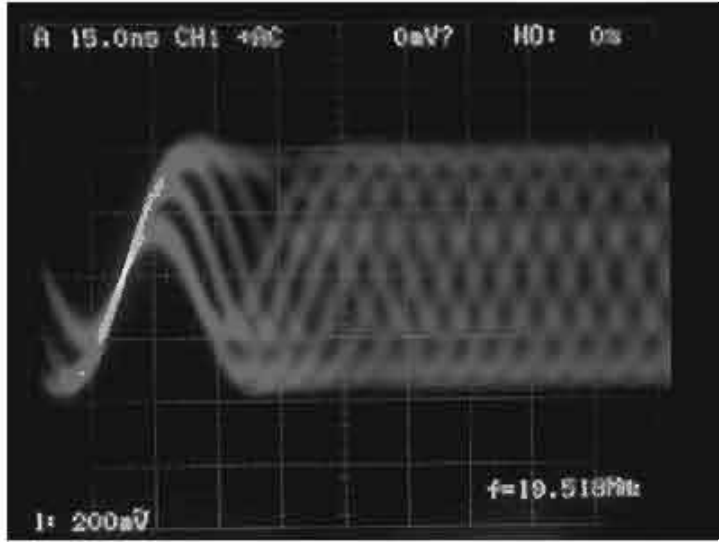

① ATEST

⑪ SPD  
⑫ FG

## BD PLAY (INNER)

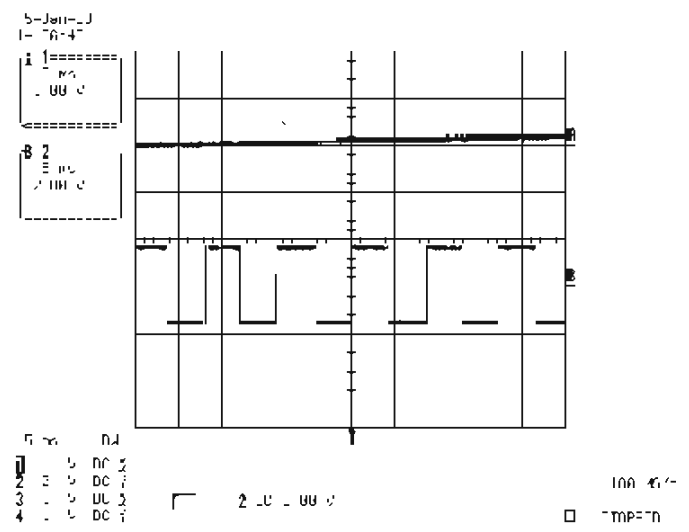

## BD LOADING → PLAY

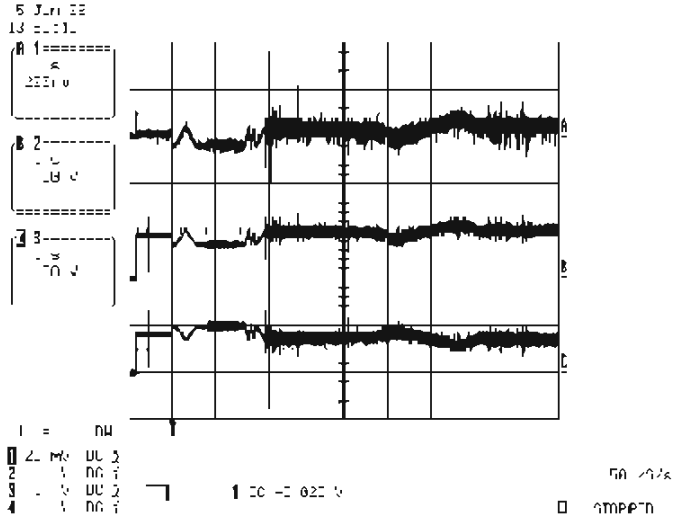

② FODP  
③ FCS1+  
④ FCS1-

⑬ SLED+  
⑭ SLED-  
⑮ SL1+  
⑯ SL2-

## BD SEARCH (INNER → OUTER)

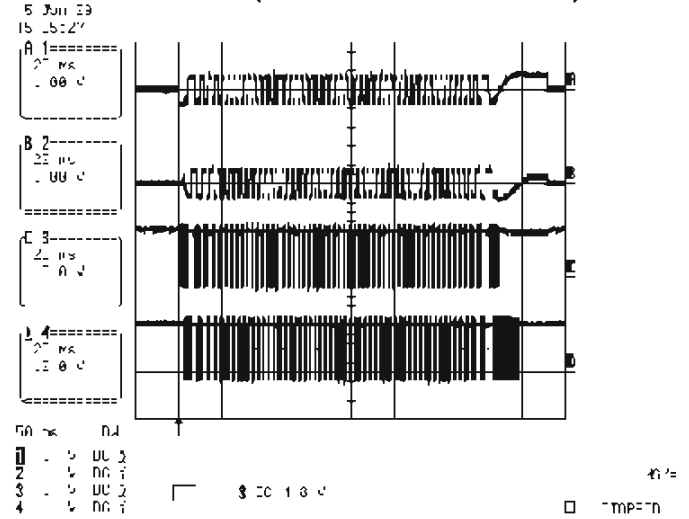

## BD LOADING → PLAY

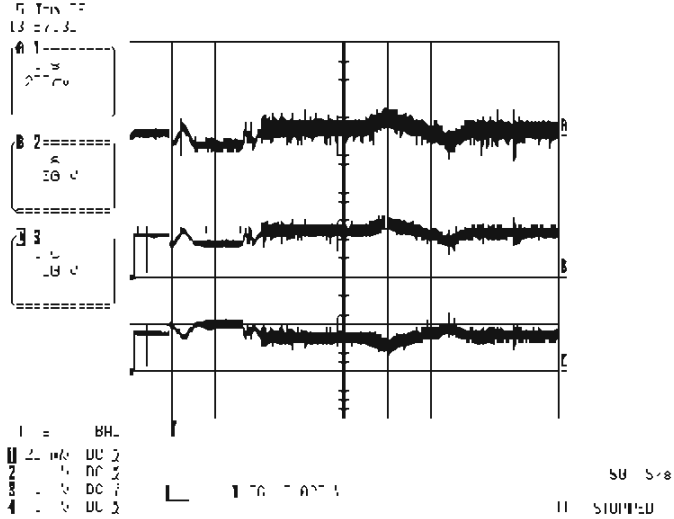

⑤ FODN  
⑥ FCS2+  
⑦ FCS2-

⑬ SLED+  
⑭ SLED-  
⑮ SL1+  
⑯ SL2-

## BD SEARCH (OUTER → INNER)

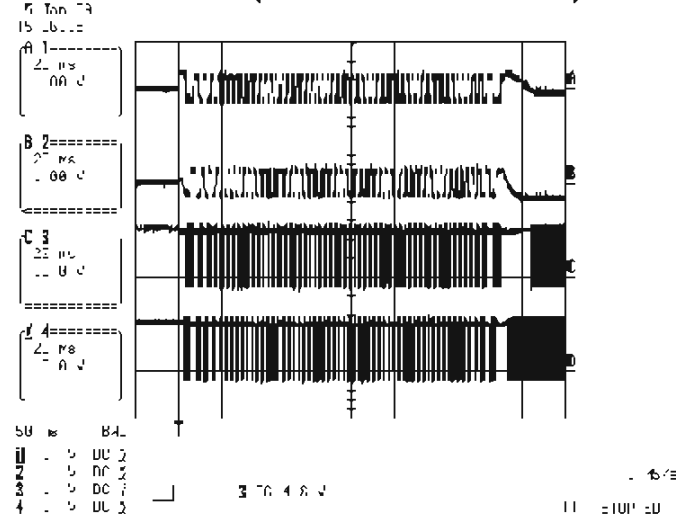

## BD PLAY

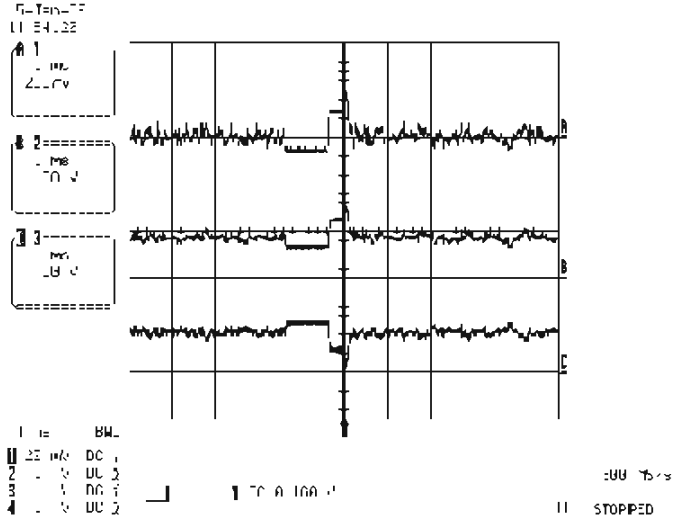

⑧ TRD  
⑨ TRK+  
⑩ TRK-

# DVD PLAY Disc : TDV-520A

## HF wave form

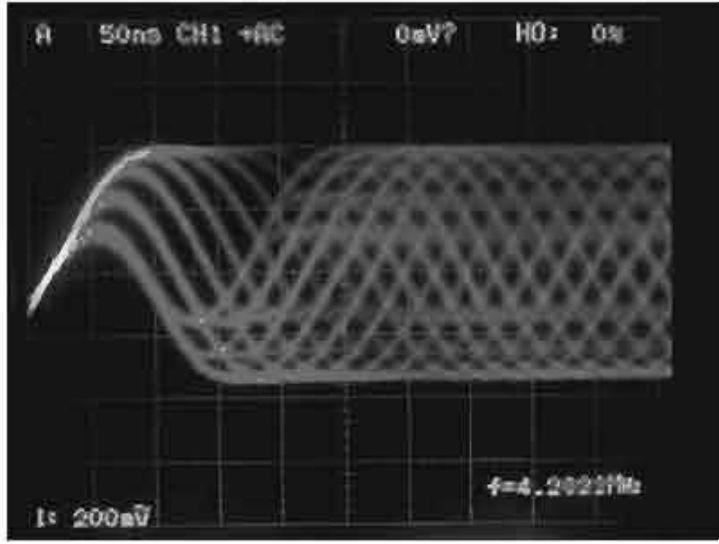

① ATEST

⑪ SPD  
⑫ FG

## DVD PLAY (INNER)

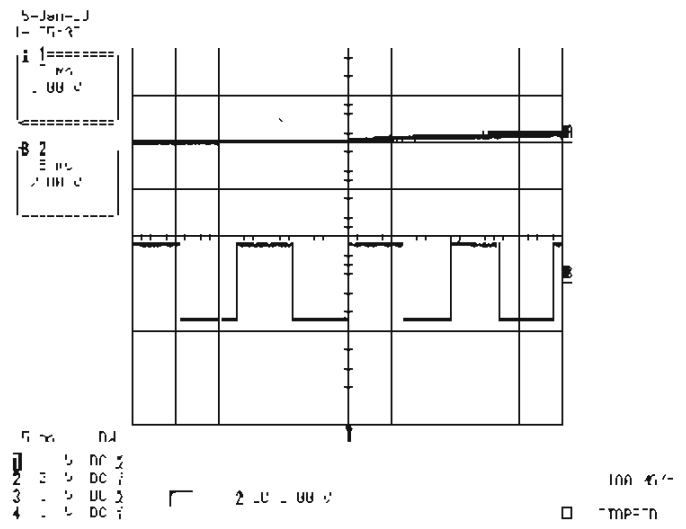

## DVD LOADING → PLAY

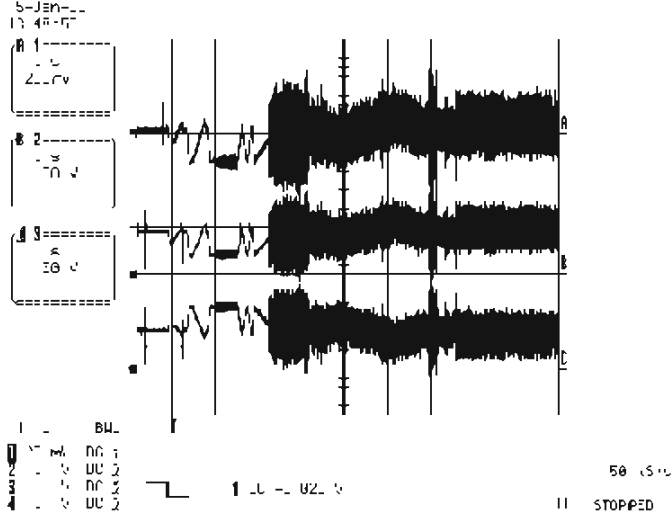

② FODP  
③ FCS1+  
④ FCS1-

⑬ SLED+  
⑭ SLED-  
⑮ SL1+  
⑯ SL2-

## DVD SEARCH (INNER → OUTER)

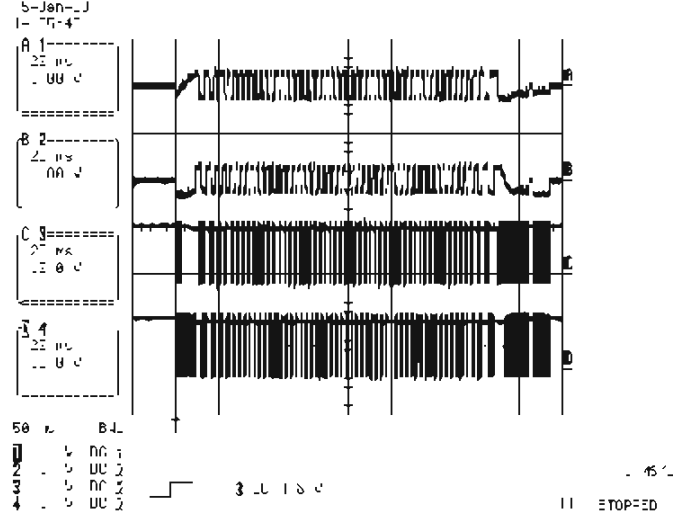

## DVD LOADING → PLAY

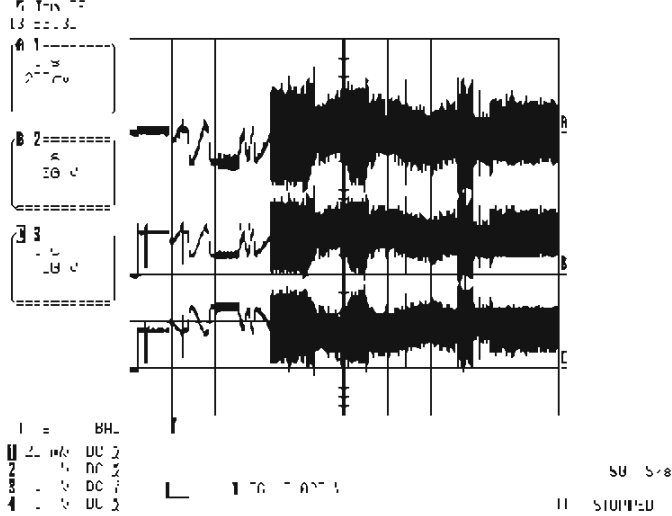

⑤ FODN  
⑥ FCS2+  
⑦ FCS2-

⑬ SLED+  
⑭ SLED-  
⑮ SL1+  
⑯ SL2-

## DVD SEARCH (OUTER → INNER)

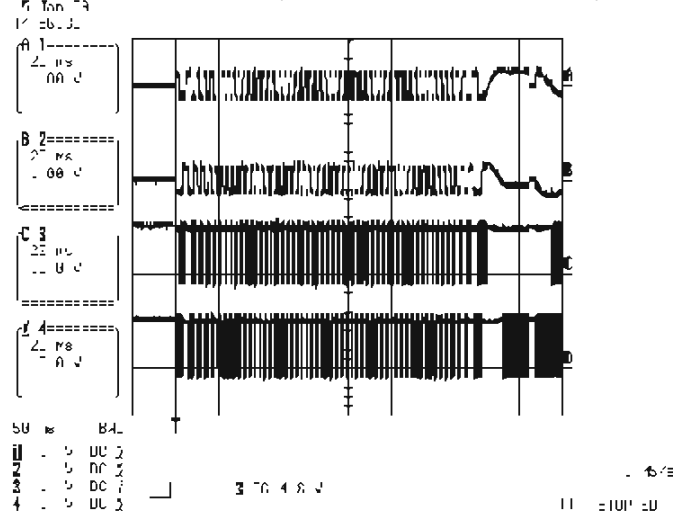

## DVD PLAY

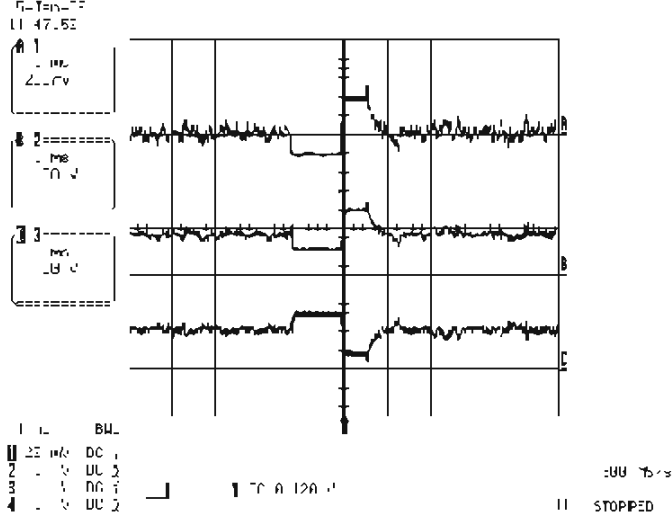

⑧ TRD  
⑨ TRK+  
⑩ TRK-

# CD PLAY Disc: TCD-784

## HF wave form

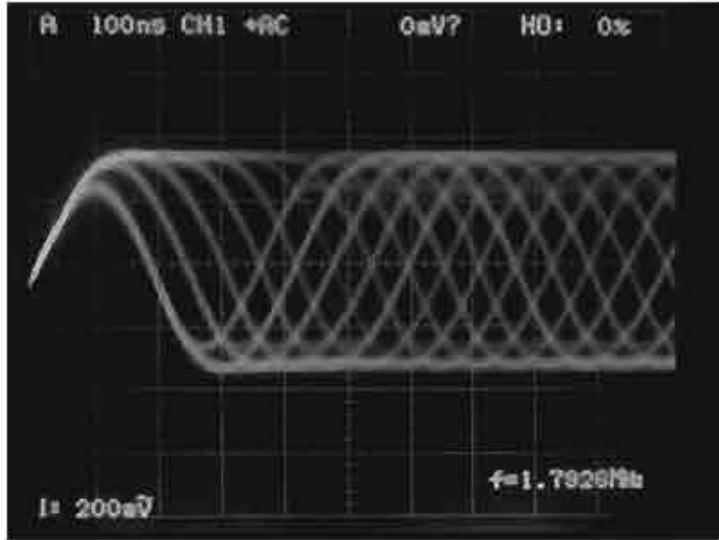

① ATEST

⑪ SPD  
⑫ FG

## CD PLAY (INNER)

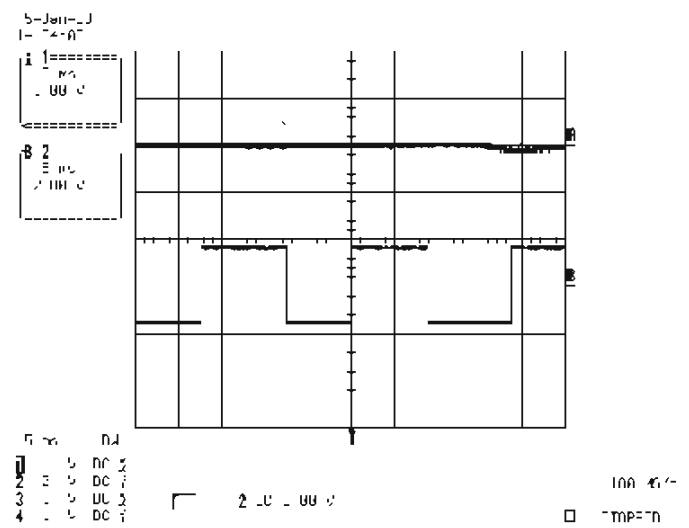

## CD LOADING → PLAY

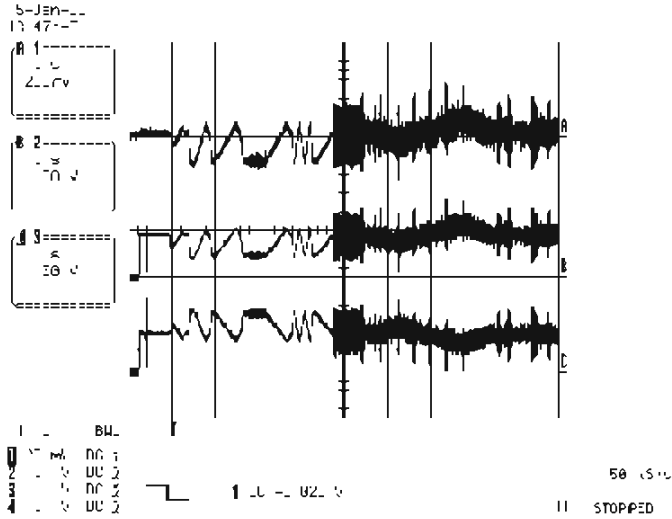

② FODP  
③ FCS1+  
④ FCS1-

⑬ SLED+  
⑭ SLED-  
⑮ SL1+  
⑯ SL2-

## CD SEARCH (INNER → OUTER)

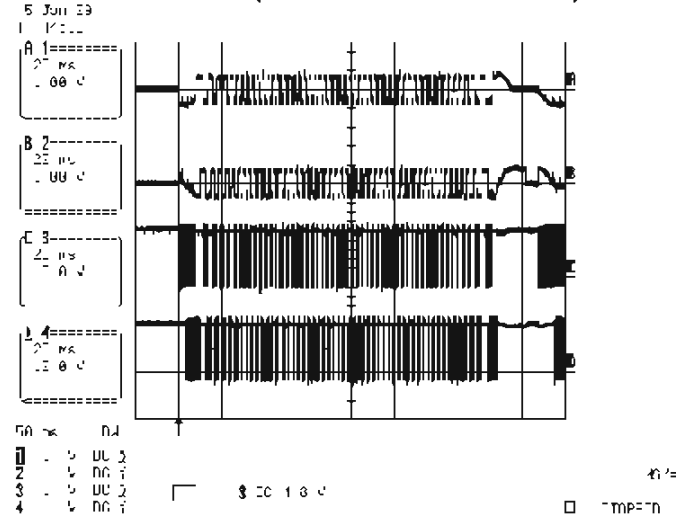

## CD LOADING → PLAY

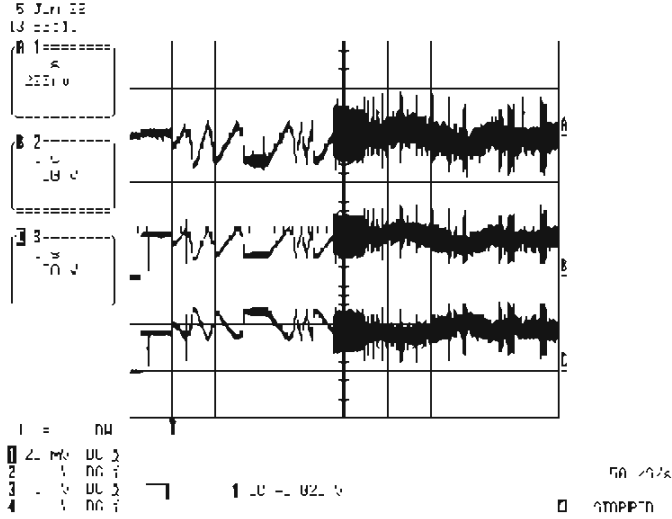

⑤ FODN  
⑥ FCS2+  
⑦ FCS2-

⑬ SLED+  
⑭ SLED-  
⑮ SL1+  
⑯ SL2-

## CD SEARCH (OUTER → INNER)

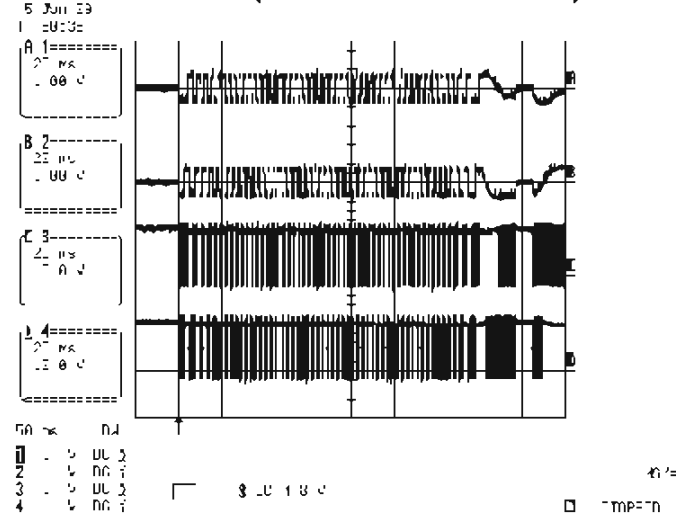

## CD PLAY

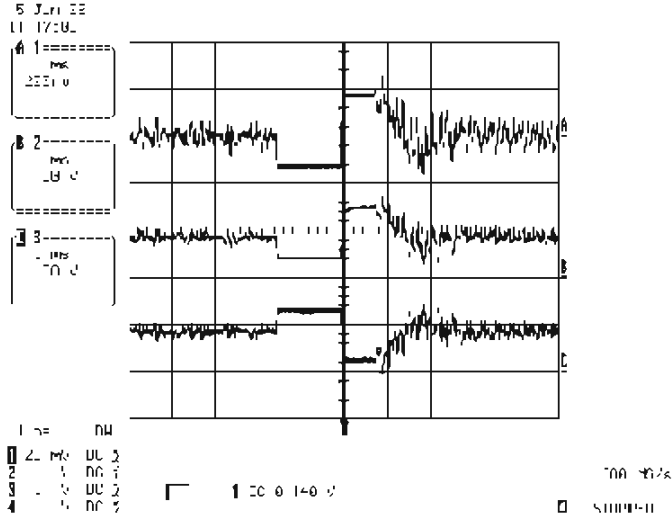

⑧ TRD  
⑨ TRK+  
⑩ TRK-

# ANALOG VIDEO OUTPUT SIGNAL

Signal: Color Bar 100%

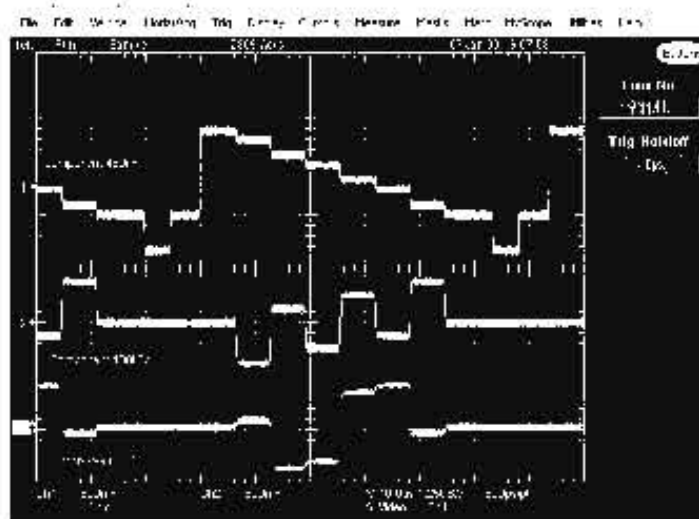
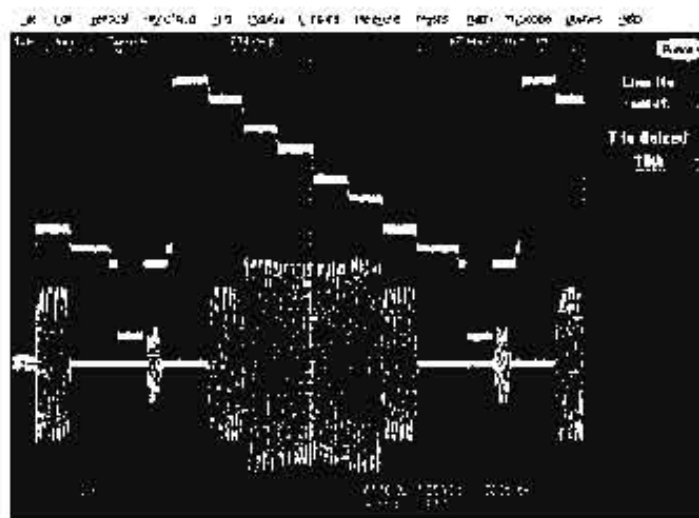
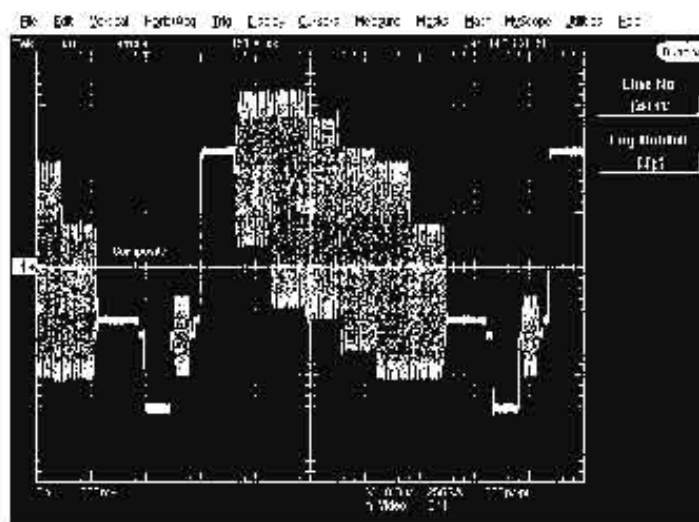
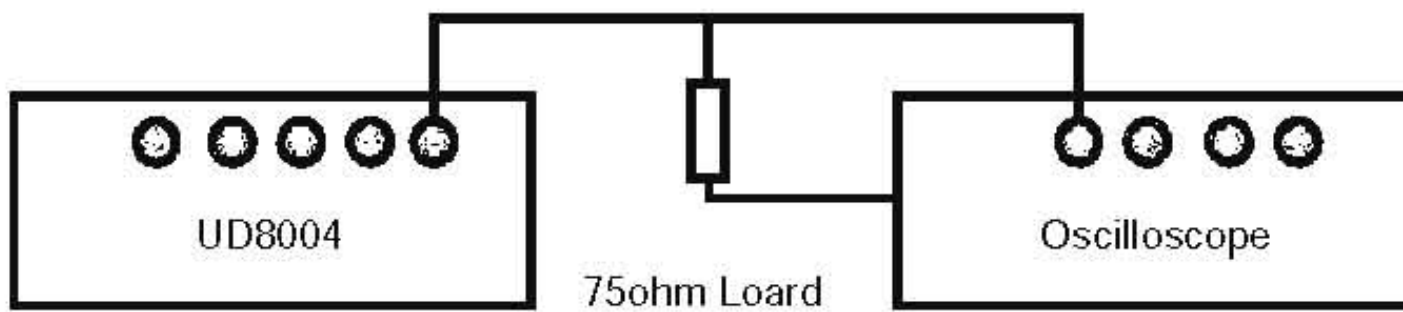

## NOTE FOR SCHEMATIC DIAGRAM

### WARNING:

Parts marked with this symbol  $\triangle$  have critical characteristics.  
Use ONLY replacement parts recommended by the manufacturer.

### CAUTION:

Before returning the unit to the customer, make sure you make either (1) a leakage current check or (2) a line to chassis resistance check. If the leakage current exceeds 0.5 milliamps, or if the resistance from chassis to either side of the power cord is less than 460 kohms, the unit is defective.

### WARNING:

DO NOT return the unit to the customer until the problem is located and corrected.

### NOTICE:

ALL RESISTANCE VALUES IN OHM. k=1,000 OHM  
M=1,000,000 OHM  
ALL CAPACITANCE VALUES IN MICRO FARAD.  
P=MICRO-MICRO FARAD  
EACH VOLTAGE AND CURRENT ARE MEASURED AT  
NO SIGNAL INPUT CONDITION.  
CIRCUIT AND PARTS ARE SUBJECT TO CHANGE  
WITHOUT PRIOR NOTICE.



BD/SACD/DVD/CD PLAY DATA OUTPUT SIGNAL LINE

SACD/DVD/CD PLAY DATA OUTPUT SIGNAL LINE

BD PLAY DATA OUTPUT SIGNAL LINE

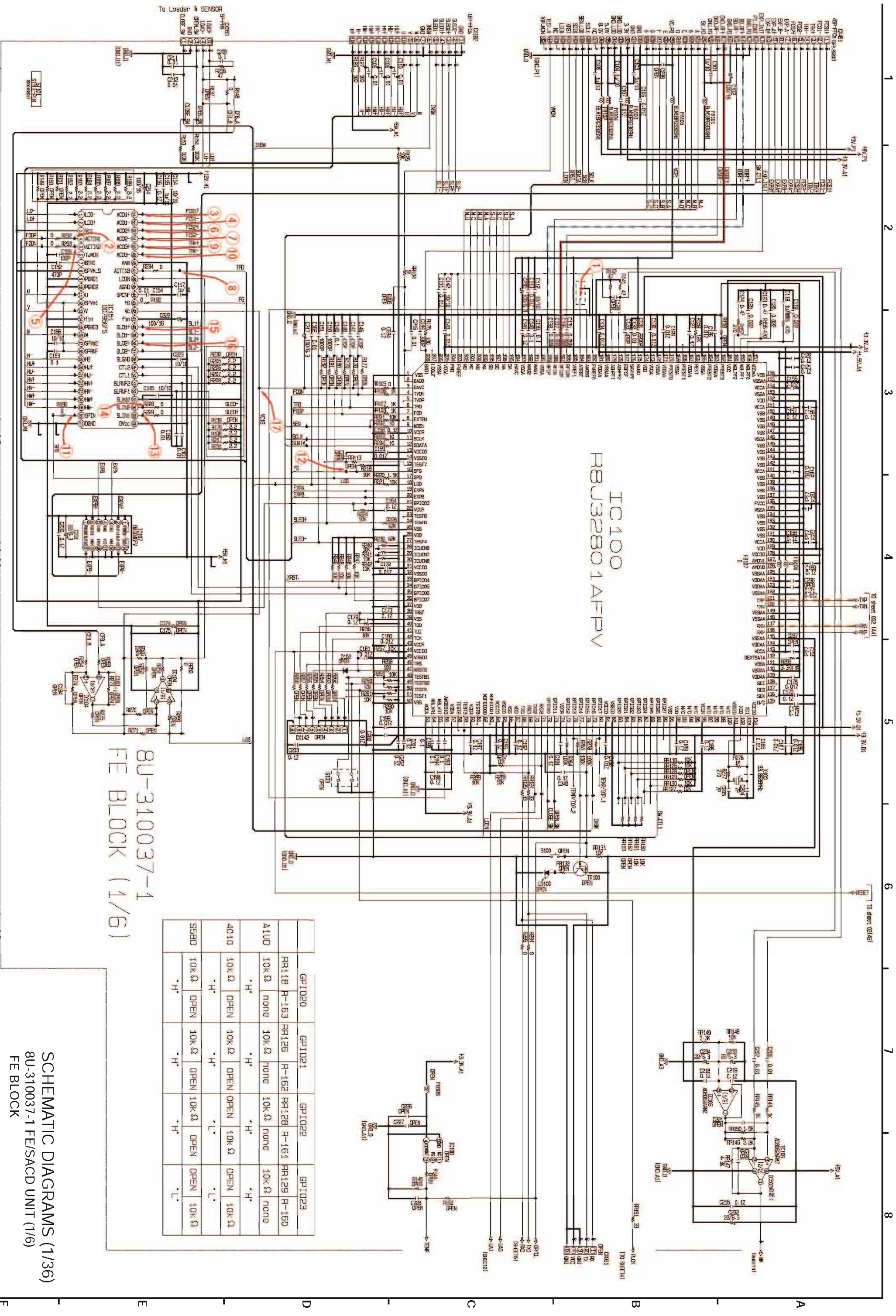

8U-310037-1  
FE BLOCK (1/6)

	GP1020	GP1021	GP1022	GP1023
A1UD	RR118 R-153	RR126 R-152	RR128 R-151	RR129 R-150
4010	10K Ω	none	10K Ω	none
SSBD	10K Ω	OPEN	10K Ω	OPEN
	10K Ω	OPEN	10K Ω	OPEN
	10K Ω	OPEN	10K Ω	OPEN

SCHEMATIC DIAGRAMS (1/36)  
8U-310037-1 FE/SACD UNIT (1/6)  
FE BLOCK

UD8004



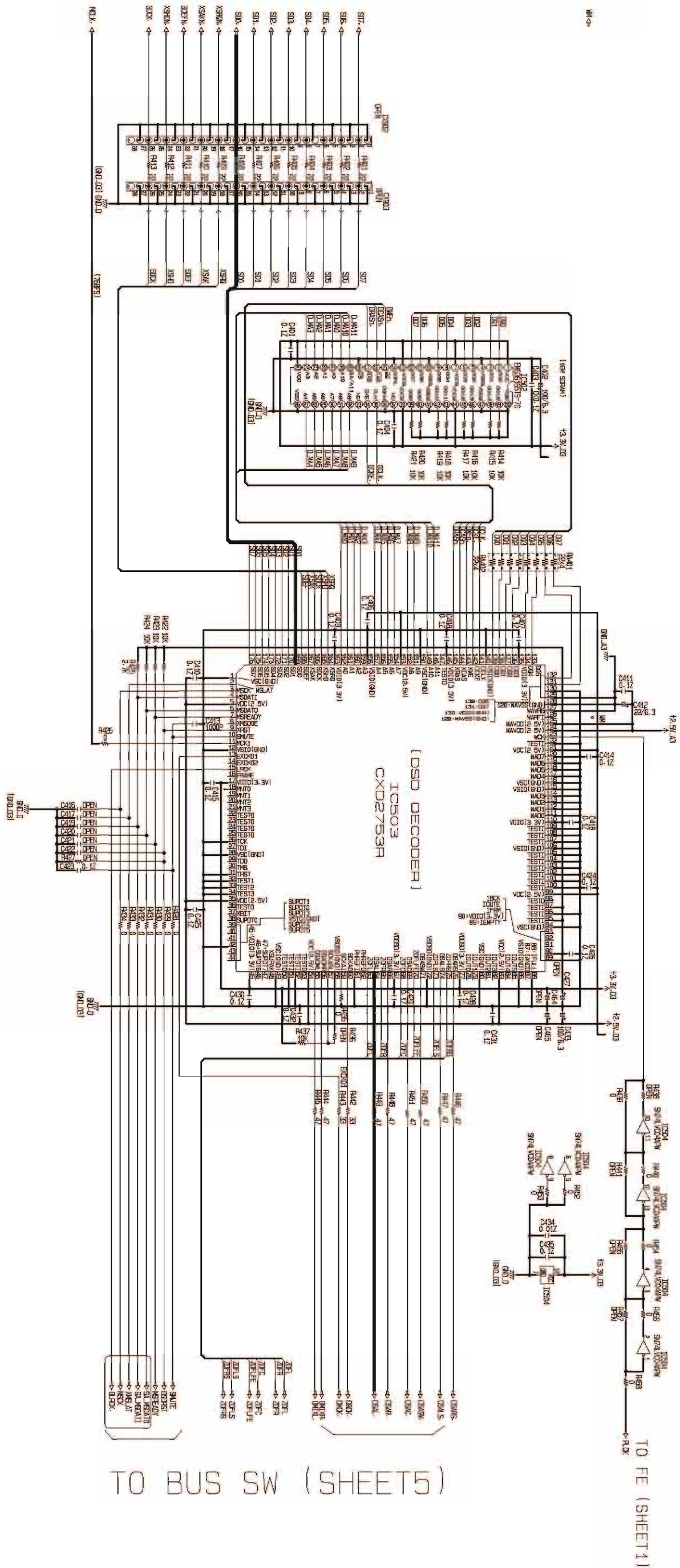

BU-310037-1  
SACD DECODE BLOCK (3/6)

— SACD PLAY DATA OUTPUT SIGNAL LINE

SCHEMATIC DIAGRAMS (3/36)  
8U-310037-1 FE/SACD UNIT (3/6)  
SACD DECODE BLOCK

1 2 3 4 5 6 7 8

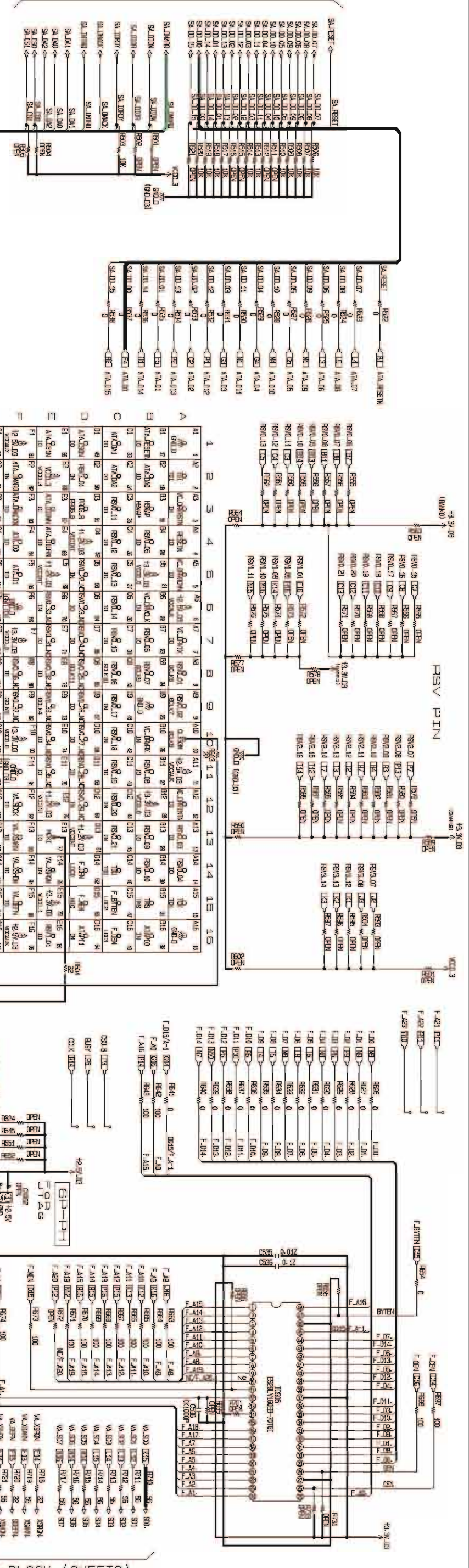

CONFAG SETTING

Model	Setting
BPI UP(O.1.0)	0
HSWAP	Disable
OSI.B	Enable
POWER	Write Enable
DONE	active drive

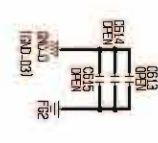
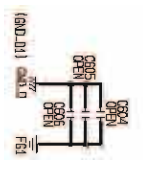

	1	2	3	4	5	7	8	9	10	11	12	13	14	15	16
A	AV1.01	AV1.02	AV1.03	AV1.04	AV1.05	AV1.06	AV1.07	AV1.08	AV1.09	AV1.10	AV1.11	AV1.12	AV1.13	AV1.14	AV1.15
B	AV1.16	AV1.17	AV1.18	AV1.19	AV1.20	AV1.21	AV1.22	AV1.23	AV1.24	AV1.25	AV1.26	AV1.27	AV1.28	AV1.29	AV1.30
C	AV1.31	AV1.32	AV1.33	AV1.34	AV1.35	AV1.36	AV1.37	AV1.38	AV1.39	AV1.40	AV1.41	AV1.42	AV1.43	AV1.44	AV1.45
D	AV1.46	AV1.47	AV1.48	AV1.49	AV1.50	AV1.51	AV1.52	AV1.53	AV1.54	AV1.55	AV1.56	AV1.57	AV1.58	AV1.59	AV1.60
E	AV1.61	AV1.62	AV1.63	AV1.64	AV1.65	AV1.66	AV1.67	AV1.68	AV1.69	AV1.70	AV1.71	AV1.72	AV1.73	AV1.74	AV1.75
F	AV1.76	AV1.77	AV1.78	AV1.79	AV1.80	AV1.81	AV1.82	AV1.83	AV1.84	AV1.85	AV1.86	AV1.87	AV1.88	AV1.89	AV1.90
G	AV1.91	AV1.92	AV1.93	AV1.94	AV1.95	AV1.96	AV1.97	AV1.98	AV1.99	AV1.100	AV1.101	AV1.102	AV1.103	AV1.104	AV1.105
H	AV1.106	AV1.107	AV1.108	AV1.109	AV1.110	AV1.111	AV1.112	AV1.113	AV1.114	AV1.115	AV1.116	AV1.117	AV1.118	AV1.119	AV1.120
I	AV1.121	AV1.122	AV1.123	AV1.124	AV1.125	AV1.126	AV1.127	AV1.128	AV1.129	AV1.130	AV1.131	AV1.132	AV1.133	AV1.134	AV1.135
J	AV1.136	AV1.137	AV1.138	AV1.139	AV1.140	AV1.141	AV1.142	AV1.143	AV1.144	AV1.145	AV1.146	AV1.147	AV1.148	AV1.149	AV1.150
K	AV1.151	AV1.152	AV1.153	AV1.154	AV1.155	AV1.156	AV1.157	AV1.158	AV1.159	AV1.160	AV1.161	AV1.162	AV1.163	AV1.164	AV1.165
L	AV1.166	AV1.167	AV1.168	AV1.169	AV1.170	AV1.171	AV1.172	AV1.173	AV1.174	AV1.175	AV1.176	AV1.177	AV1.178	AV1.179	AV1.180
M	AV1.181	AV1.182	AV1.183	AV1.184	AV1.185	AV1.186	AV1.187	AV1.188	AV1.189	AV1.190	AV1.191	AV1.192	AV1.193	AV1.194	AV1.195
N	AV1.196	AV1.197	AV1.198	AV1.199	AV1.200	AV1.201	AV1.202	AV1.203	AV1.204	AV1.205	AV1.206	AV1.207	AV1.208	AV1.209	AV1.210
P	AV1.211	AV1.212	AV1.213	AV1.214	AV1.215	AV1.216	AV1.217	AV1.218	AV1.219	AV1.220	AV1.221	AV1.222	AV1.223	AV1.224	AV1.225
Q	AV1.226	AV1.227	AV1.228	AV1.229	AV1.230	AV1.231	AV1.232	AV1.233	AV1.234	AV1.235	AV1.236	AV1.237	AV1.238	AV1.239	AV1.240
R	AV1.241	AV1.242	AV1.243	AV1.244	AV1.245	AV1.246	AV1.247	AV1.248	AV1.249	AV1.250	AV1.251	AV1.252	AV1.253	AV1.254	AV1.255
S	AV1.256	AV1.257	AV1.258	AV1.259	AV1.260	AV1.261	AV1.262	AV1.263	AV1.264	AV1.265	AV1.266	AV1.267	AV1.268	AV1.269	AV1.270
T	AV1.271	AV1.272	AV1.273	AV1.274	AV1.275	AV1.276	AV1.277	AV1.278	AV1.279	AV1.280	AV1.281	AV1.282	AV1.283	AV1.284	AV1.285

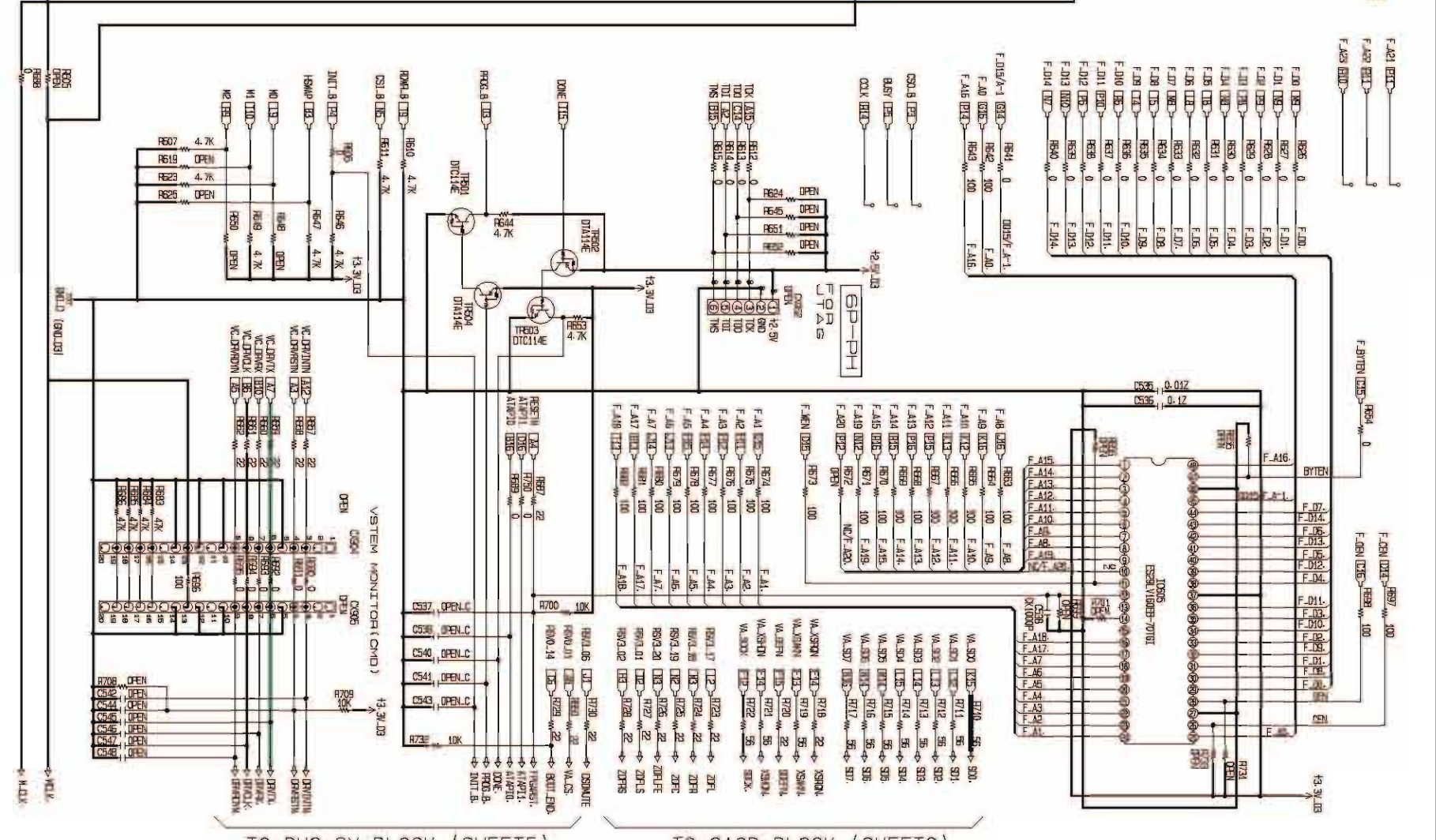
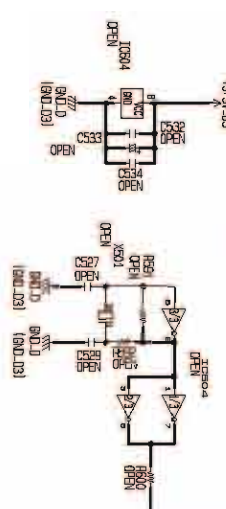
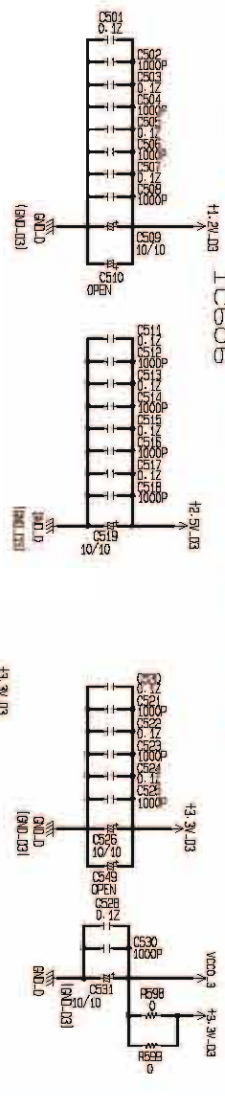

BU-310037-1  
VSTEM-ATAPI BLOCK (4/6)

SACD PLAY DATA OUTPUT SIGNAL LINE  
SACD CONTROL DATA OUTPUT SIGNAL LINE

SCHEMATIC DIAGRAMS (4/36)  
8U-310037-1 FE/SACD UNIT (4/6)  
VSTEM-ATAPI BLOCK

TO FE (SHEET2)

TO SACD FPGA (SHEET4)

TO SACD CXD2753R (SHEET3)

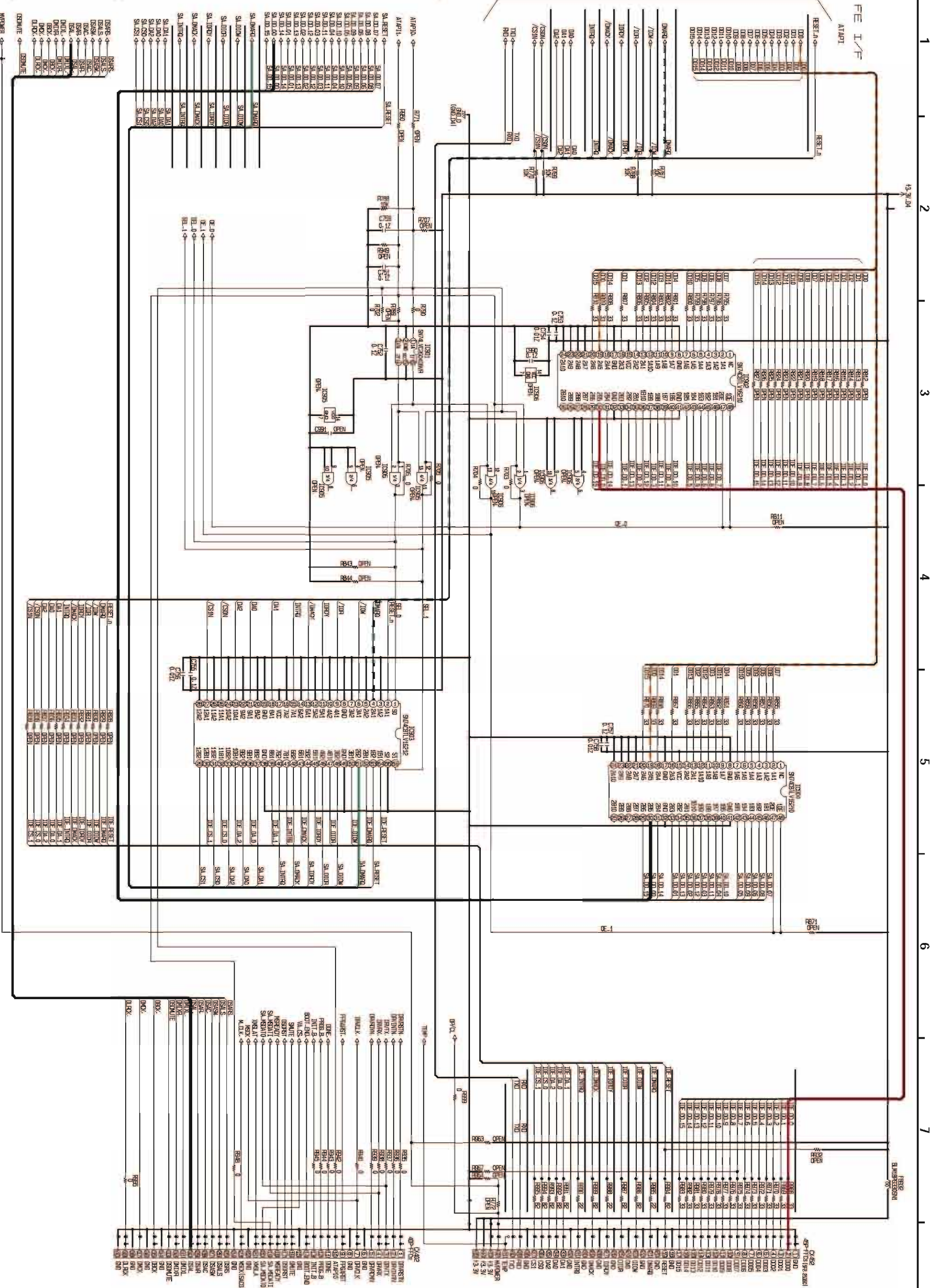

BU-310037-1  
BUS SW BLOCK (5/6)

- BD/SACD/DVD/CD PLAY DATA OUTPUT SIGNAL LINE
- BD/DVD/CD PLAY DATA OUTPUT SIGNAL LINE
- - - BD/SACD/DVD/CD CONTROL DATA OUTPUT SIGNAL LINE
- SACD PLAY DATA OUTPUT SIGNAL LINE
- SACD CONTROL DATA OUTPUT SIGNAL LINE

SCHEMATIC DIAGRAMS (5/36)  
8U-310037-1 FE/SACD UNIT (5/6)  
BUS SW BLOCK

TO BE (8U-310001)

TO BE (8U-310001)

UD8004

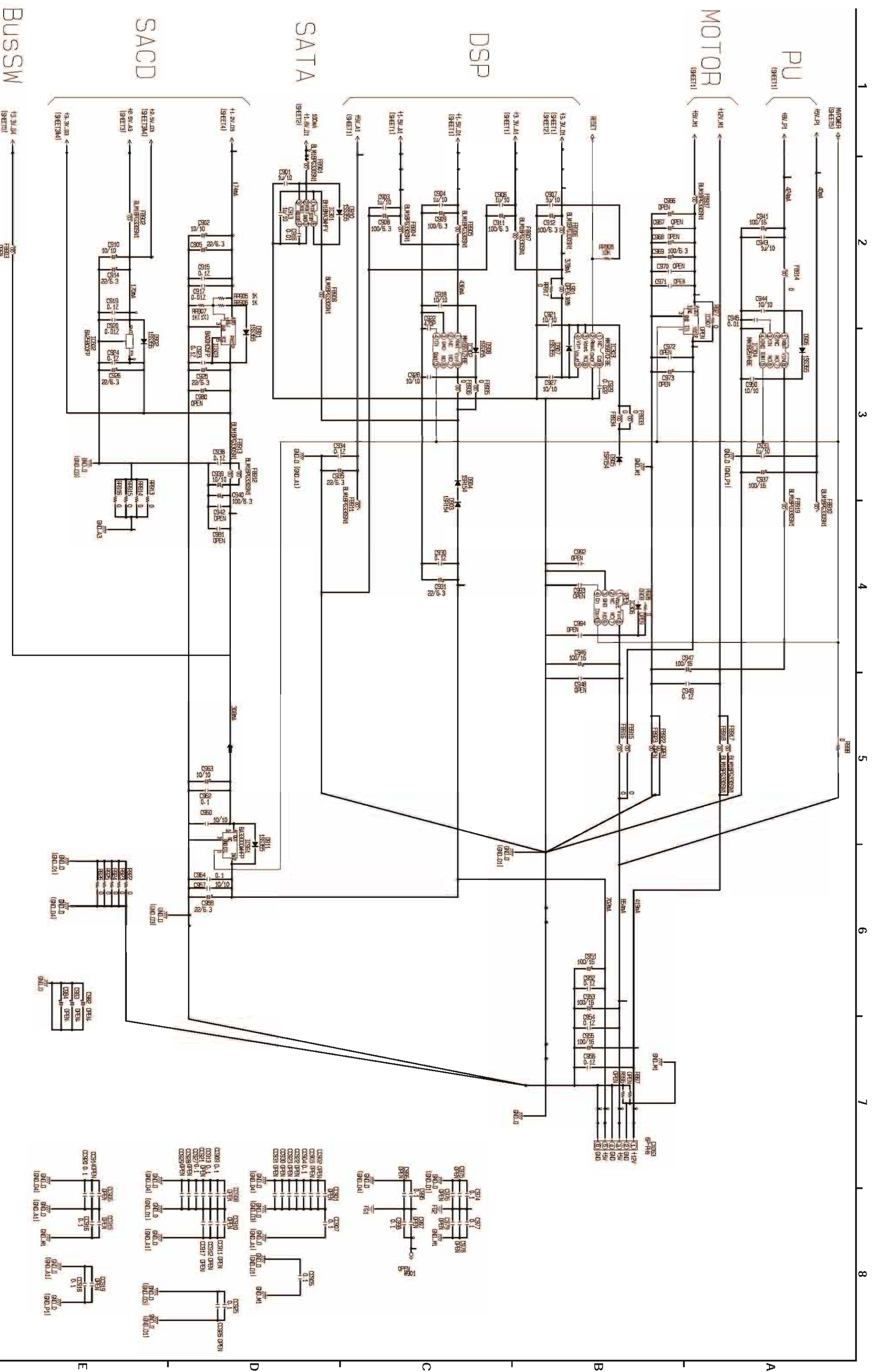

BU-310037-1  
POWER BLOCK (6/6)

SCHEMATIC DIAGRAMS (6/36)  
8U-310037-1 FE/SACD UNIT (6/6)  
POWER BLOCK

UD8004

AN	AI	AL	AK	AJ	AH	AG	AF	AE	AD	AC	AB	AA	Y	W	V	U	T	R	P	N	M	L	K	J	H	G	F	E	D	C	B	A																																																																			
AN01	AN02	AN03	AN04	AN05	AN06	AN07	AN08	AN09	AN10	AN11	AN12	AN13	AN14	AN15	AN16	AN17	AN18	AN19	AN20	AN21	AN22	AN23	AN24	AN25	AN26	AN27	AN28	AN29	AN30	AN31	AN32	AN33	AN34	AN35	AN36	AN37	AN38	AN39	AN40	AN41	AN42	AN43	AN44	AN45	AN46	AN47	AN48	AN49	AN50	AN51	AN52	AN53	AN54	AN55	AN56	AN57	AN58	AN59	AN60	AN61	AN62	AN63	AN64	AN65	AN66	AN67	AN68	AN69	AN70	AN71	AN72	AN73	AN74	AN75	AN76	AN77	AN78	AN79	AN80	AN81	AN82	AN83	AN84	AN85	AN86	AN87	AN88	AN89	AN90	AN91	AN92	AN93	AN94	AN95	AN96	AN97	AN98	AN99	AN100

BD/DVD/CD PLAY AV OUTPUT SIGNAL LINE

UD8004 MAIN BE LSI BLOCK (1/21)

FILE NAME: HD00041.CMP/001.SHT

BD/DVD/CD PLAY AV OUTPUT SIGNAL LINE

BD/DVD/CD PLAY AUDIO OUTPUT SIGNAL LINE

COMPONENT HDMI VIDEO OUTPUT SIGNAL LINE

VIDEO, S-VIDEO OUT VIDEO OUTPUT SIGNAL LINE

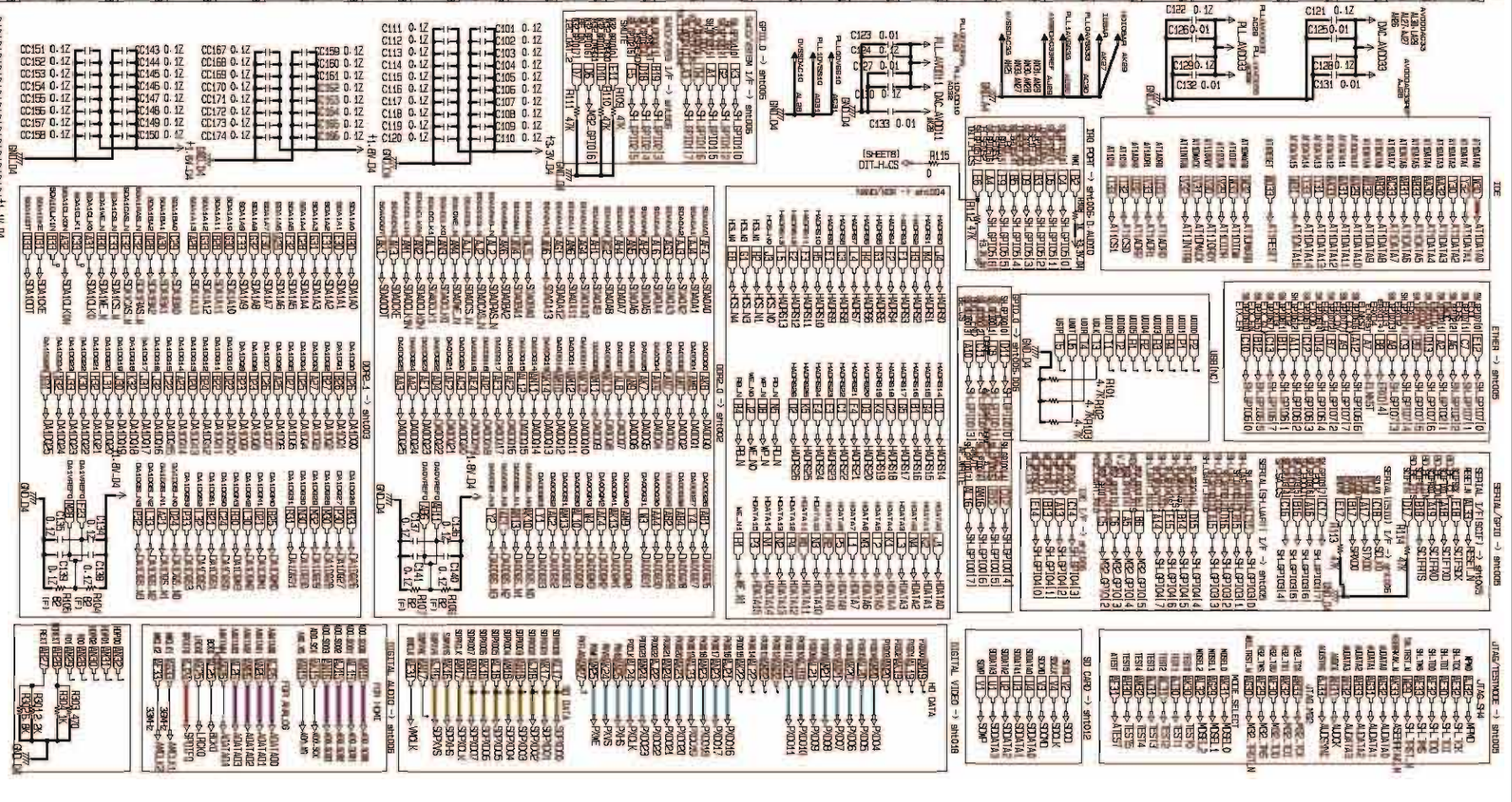

SCHEMATIC DIAGRAMS (7/36)  
8U-310041 MAIN UNIT(1/21)  
BE LSI BLOCK

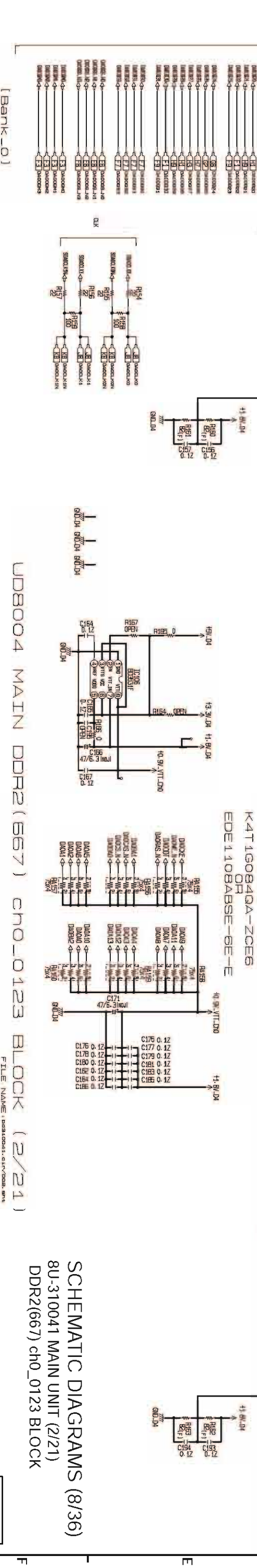
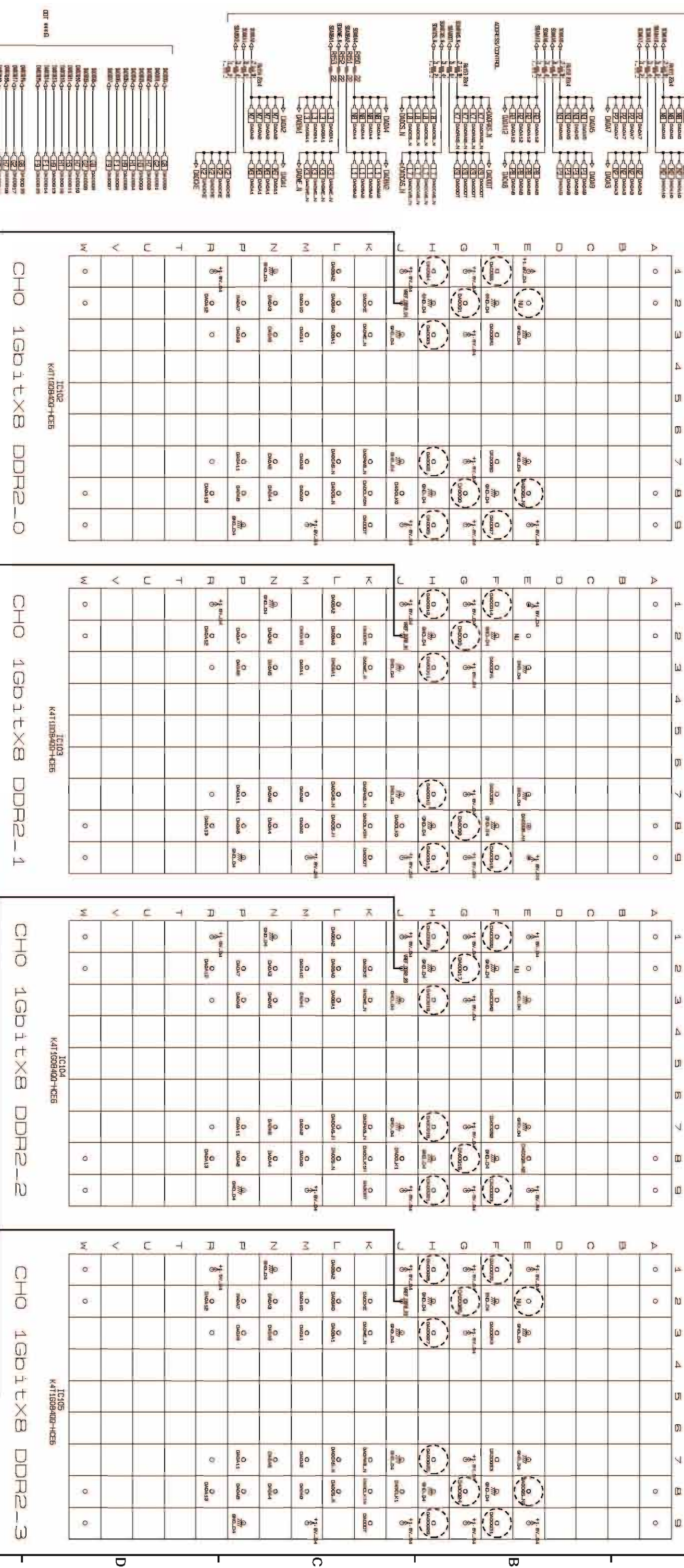
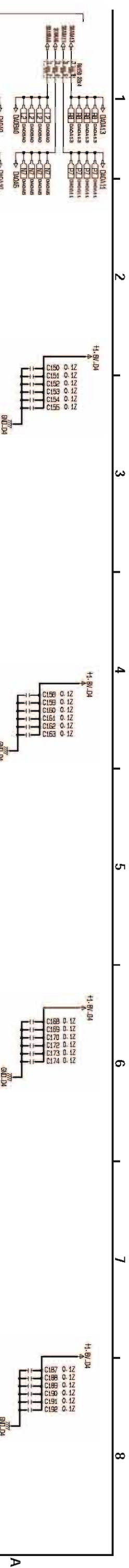

[Bank\_0]

UD8004 MAIN DDR2 (667) CHO\_0123 BLOCK (2/21)

UD8004

SCHEMATIC DIAGRAMS (8/36)  
 8U-310041 MAIN UNIT (2/21)  
 DDR2(667) cho\_0123 BLOCK

FILE NAME : B0310041.CNV.DRAW.001



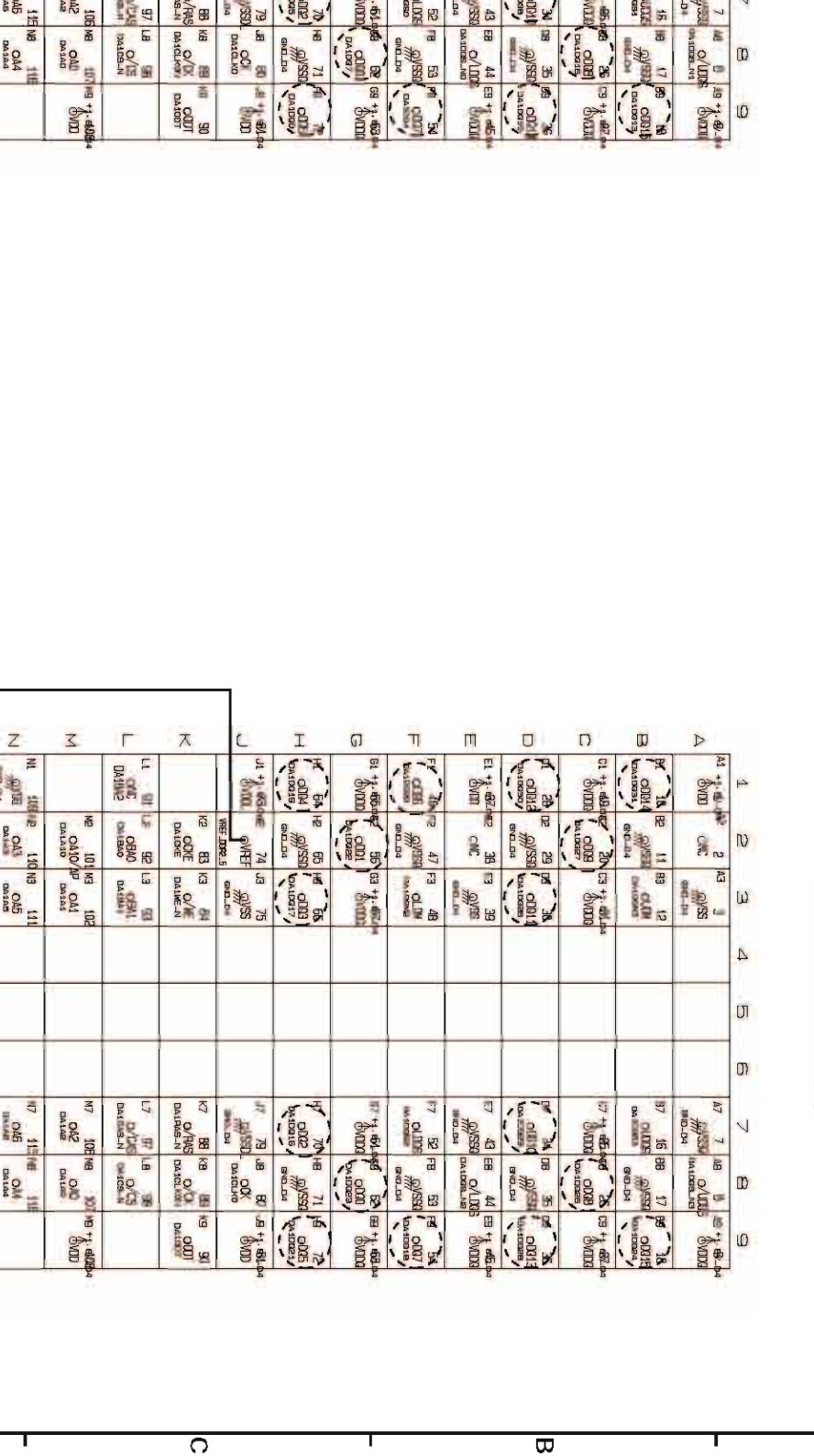
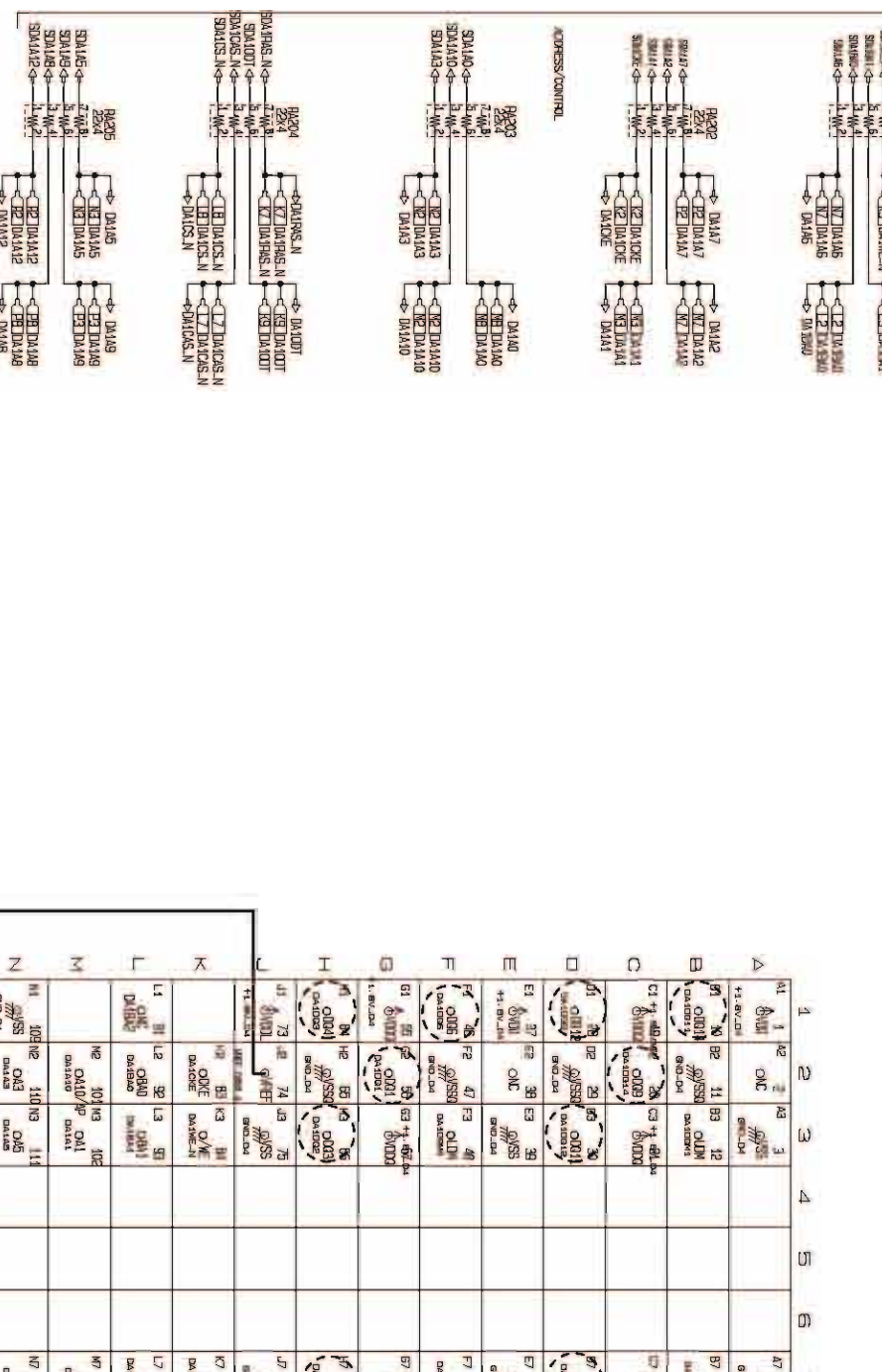
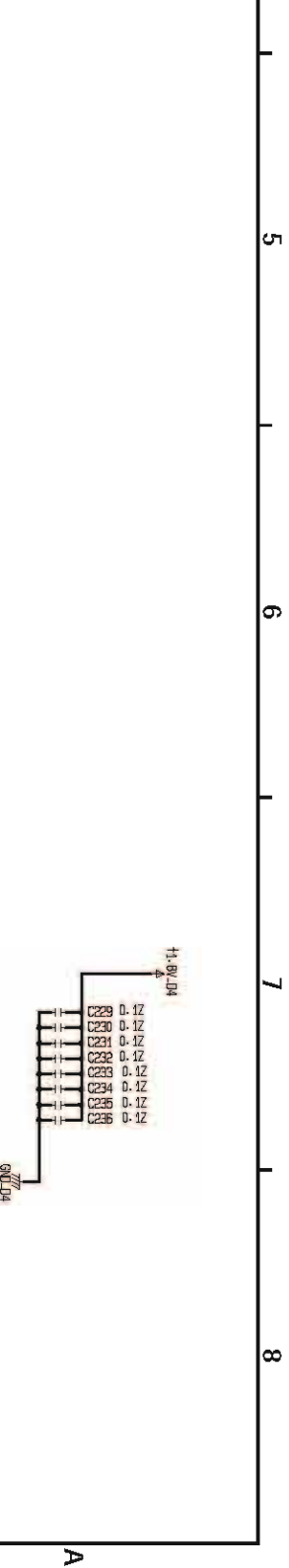
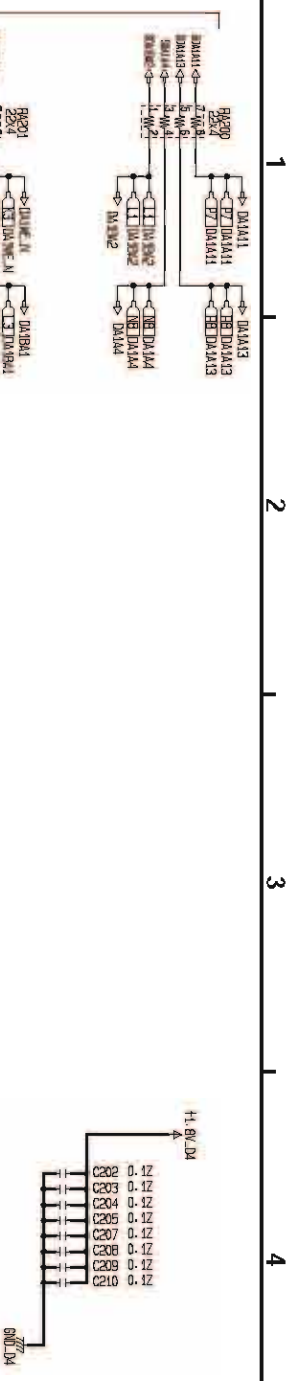

IC107  
KAT511630G-HCE6

Pin	Signal	Value
1	1-8	0000
2	9-16	0000
3	17-24	0000
4	25-32	0000
5	33-40	0000
6	41-48	0000
7	49-56	0000
8	57-64	0000
9	65-72	0000
10	73-80	0000
11	81-88	0000
12	89-96	0000
13	97-104	0000
14	105-112	0000
15	113-120	0000
16	121-128	0000
17	129-136	0000
18	137-144	0000
19	145-152	0000
20	153-160	0000
21	161-168	0000
22	169-176	0000
23	177-184	0000
24	185-192	0000
25	193-200	0000
26	201-208	0000
27	209-216	0000
28	217-224	0000
29	225-232	0000
30	233-240	0000
31	241-248	0000
32	249-256	0000
33	257-264	0000
34	265-272	0000
35	273-280	0000
36	281-288	0000
37	289-296	0000
38	297-304	0000
39	305-312	0000
40	313-320	0000
41	321-328	0000
42	329-336	0000
43	337-344	0000
44	345-352	0000
45	353-360	0000
46	361-368	0000
47	369-376	0000
48	377-384	0000
49	385-392	0000
50	393-400	0000
51	401-408	0000
52	409-416	0000
53	417-424	0000
54	425-432	0000
55	433-440	0000
56	441-448	0000
57	449-456	0000
58	457-464	0000
59	465-472	0000
60	473-480	0000
61	481-488	0000
62	489-496	0000
63	497-504	0000
64	505-512	0000
65	513-520	0000
66	521-528	0000
67	529-536	0000
68	537-544	0000
69	545-552	0000
70	553-560	0000
71	561-568	0000
72	569-576	0000
73	577-584	0000
74	585-592	0000
75	593-600	0000
76	601-608	0000
77	609-616	0000
78	617-624	0000
79	625-632	0000
80	633-640	0000
81	641-648	0000
82	649-656	0000
83	657-664	0000
84	665-672	0000
85	673-680	0000
86	681-688	0000
87	689-696	0000
88	697-704	0000
89	705-712	0000
90	713-720	0000
91	721-728	0000
92	729-736	0000
93	737-744	0000
94	745-752	0000
95	753-760	0000
96	761-768	0000
97	769-776	0000
98	777-784	0000
99	785-792	0000
100	793-800	0000
101	801-808	0000
102	809-816	0000
103	817-824	0000
104	825-832	0000
105	833-840	0000
106	841-848	0000
107	849-856	0000
108	857-864	0000
109	865-872	0000
110	873-880	0000
111	881-888	0000
112	889-896	0000
113	897-904	0000
114	905-912	0000
115	913-920	0000
116	921-928	0000
117	929-936	0000
118	937-944	0000
119	945-952	0000
120	953-960	0000
121	961-968	0000
122	969-976	0000
123	977-984	0000
124	985-992	0000
125	993-1000	0000

CH1 512MB tX16 DDR2-4

CH1 512MB tX16 DDR2-5

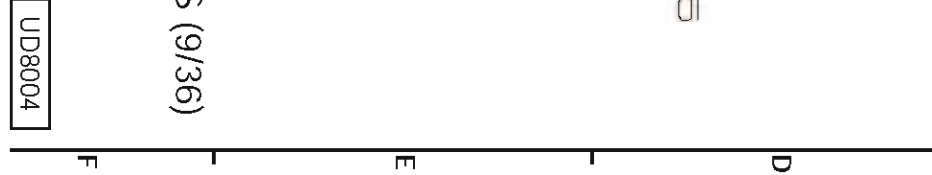
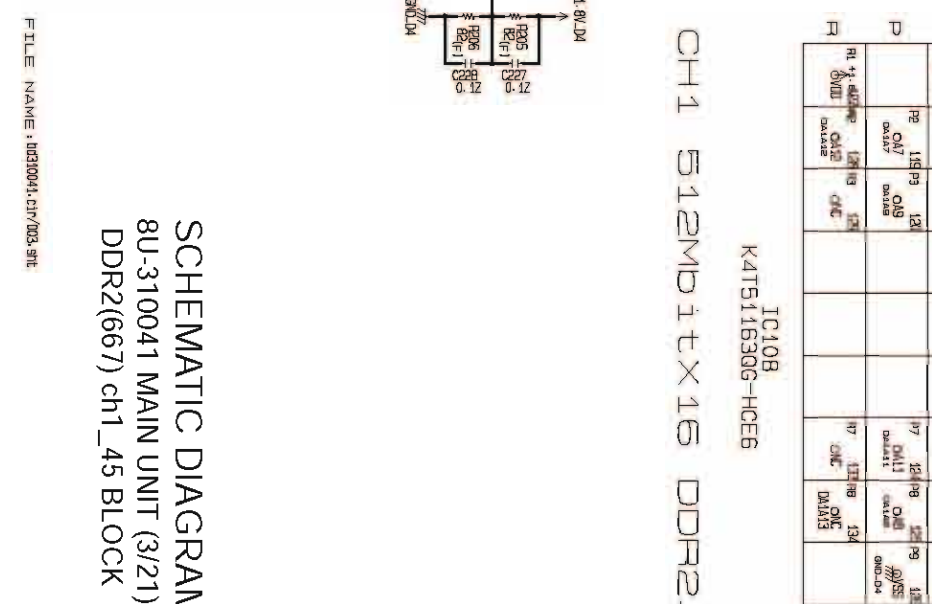
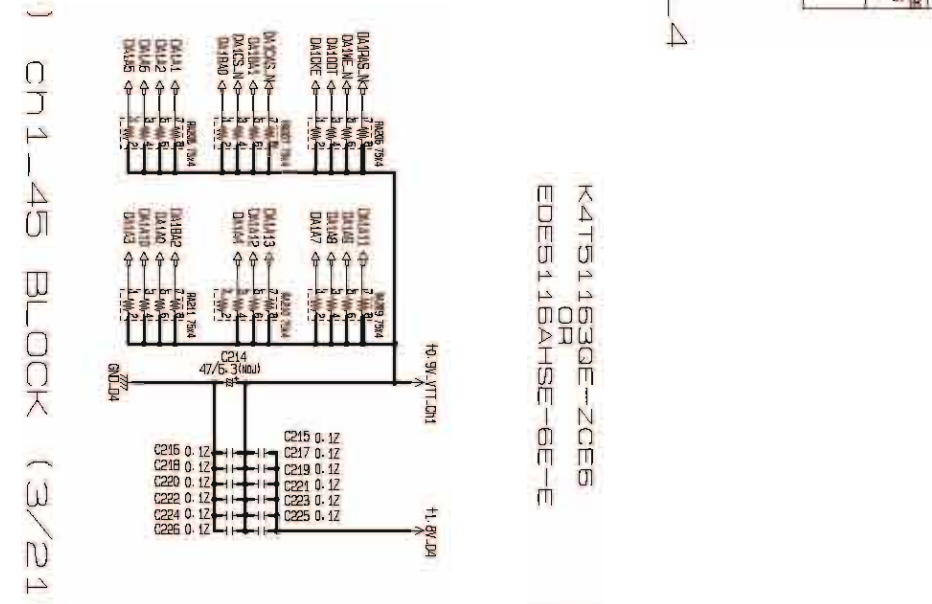
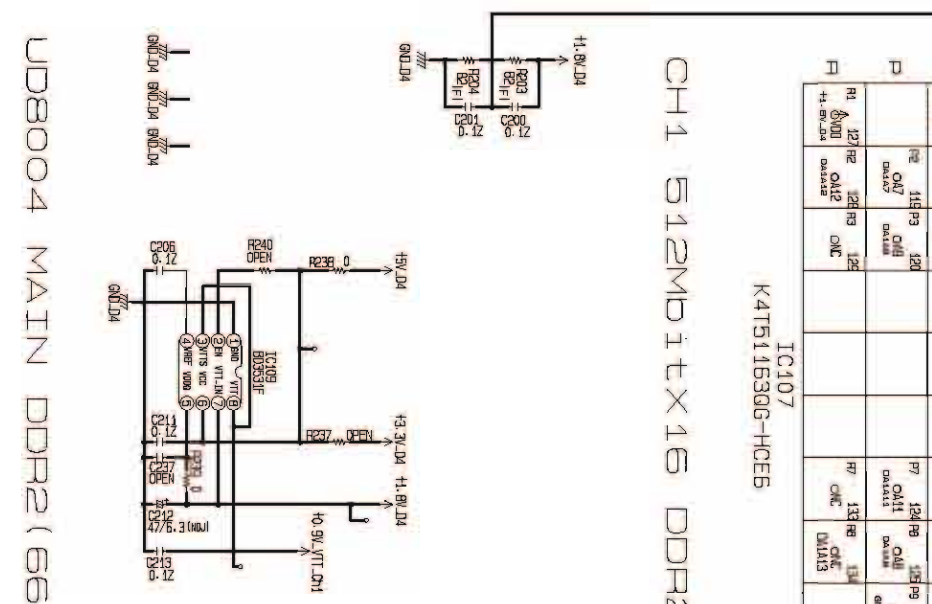
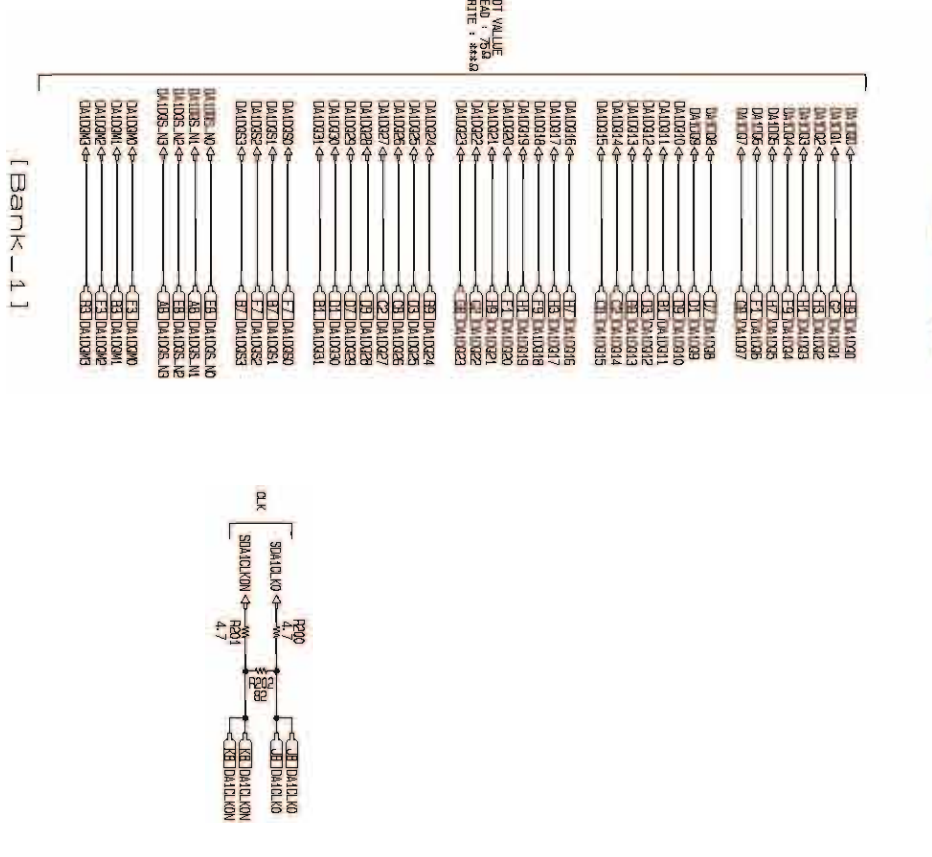
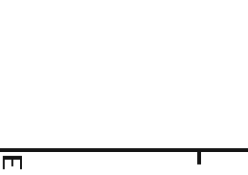
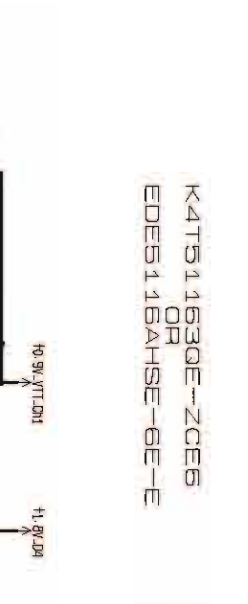
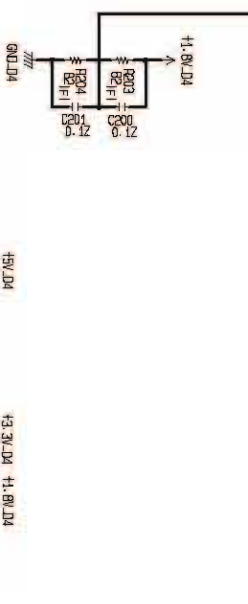

UD8004 MAIN DDR2 (667) CH1-45 BLOCK (3/21)

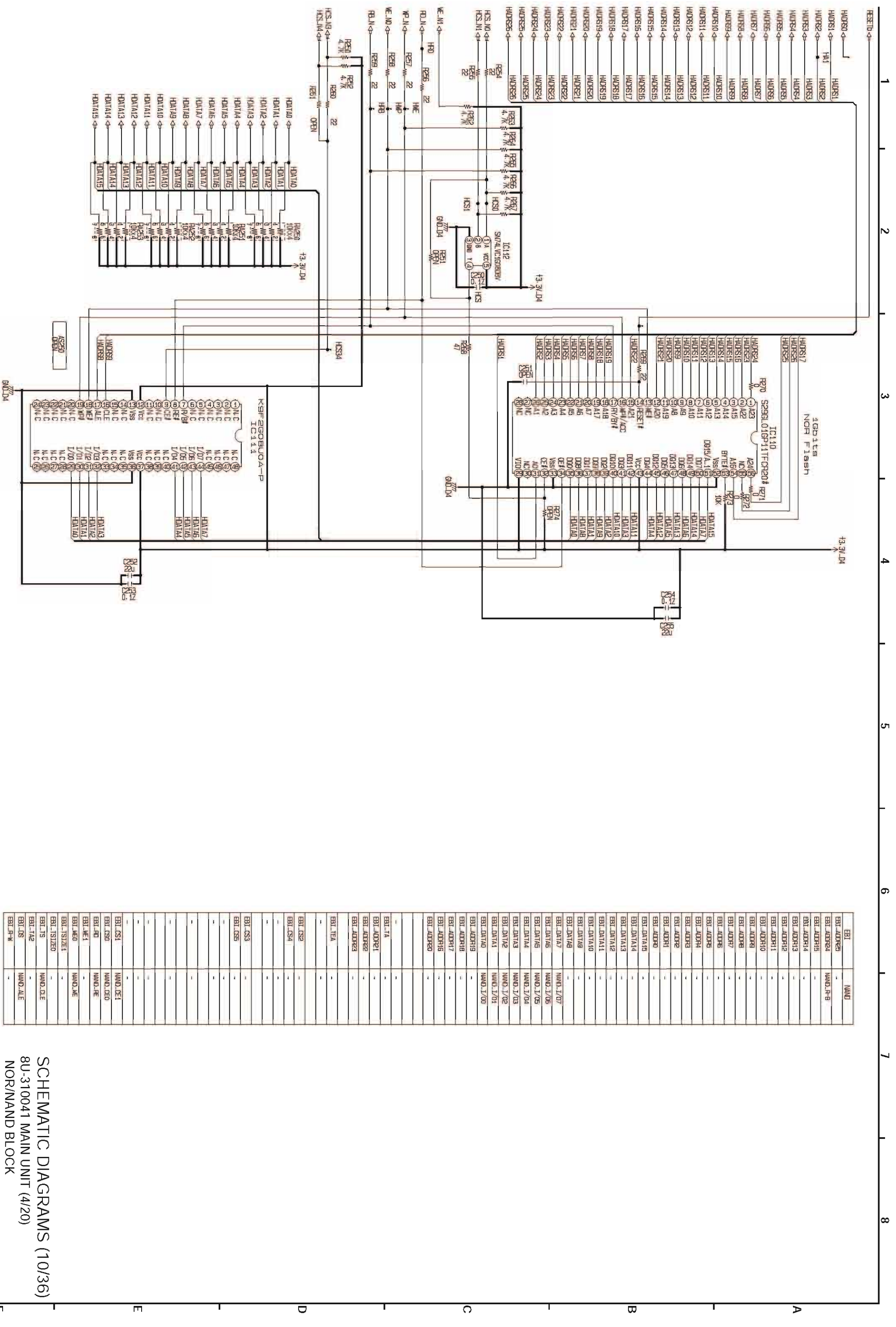

EBI	NAND
EBI_ADDR2	NAND_P-B
EBI_ADDR4	-
EBI_ADDR6	-
EBI_ADDR8	-
EBI_ADDR10	-
EBI_ADDR12	-
EBI_ADDR14	-
EBI_ADDR16	-
EBI_ADDR18	-
EBI_ADDR20	-
EBI_ADDR22	-
EBI_ADDR24	-
EBI_ADDR26	-
EBI_ADDR28	-
EBI_ADDR30	-
EBI_ADDR32	-
EBI_ADDR34	-
EBI_ADDR36	-
EBI_ADDR38	-
EBI_ADDR40	-
EBI_ADDR42	-
EBI_ADDR44	-
EBI_ADDR46	-
EBI_ADDR48	-
EBI_ADDR50	-
EBI_ADDR52	-
EBI_ADDR54	-
EBI_ADDR56	-
EBI_ADDR58	-
EBI_ADDR60	-
EBI_ADDR62	-
EBI_ADDR64	-
EBI_ADDR66	-
EBI_ADDR68	-
EBI_ADDR70	-
EBI_ADDR72	-
EBI_ADDR74	-
EBI_ADDR76	-
EBI_ADDR78	-
EBI_ADDR80	-
EBI_ADDR82	-
EBI_ADDR84	-
EBI_ADDR86	-
EBI_ADDR88	-
EBI_ADDR90	-
EBI_ADDR92	-
EBI_ADDR94	-
EBI_ADDR96	-
EBI_ADDR98	-
EBI_ADDR100	-
EBI_ADDR102	-
EBI_ADDR104	-
EBI_ADDR106	-
EBI_ADDR108	-
EBI_ADDR110	-
EBI_ADDR112	-
EBI_ADDR114	-
EBI_ADDR116	-
EBI_ADDR118	-
EBI_ADDR120	-
EBI_ADDR122	-
EBI_ADDR124	-
EBI_ADDR126	-
EBI_ADDR128	-
EBI_ADDR130	-
EBI_ADDR132	-
EBI_ADDR134	-
EBI_ADDR136	-
EBI_ADDR138	-
EBI_ADDR140	-
EBI_ADDR142	-
EBI_ADDR144	-
EBI_ADDR146	-
EBI_ADDR148	-
EBI_ADDR150	-
EBI_ADDR152	-
EBI_ADDR154	-
EBI_ADDR156	-
EBI_ADDR158	-
EBI_ADDR160	-
EBI_ADDR162	-
EBI_ADDR164	-
EBI_ADDR166	-
EBI_ADDR168	-
EBI_ADDR170	-
EBI_ADDR172	-
EBI_ADDR174	-
EBI_ADDR176	-
EBI_ADDR178	-
EBI_ADDR180	-
EBI_ADDR182	-
EBI_ADDR184	-
EBI_ADDR186	-
EBI_ADDR188	-
EBI_ADDR190	-
EBI_ADDR192	-
EBI_ADDR194	-
EBI_ADDR196	-
EBI_ADDR198	-
EBI_ADDR200	-



MAIN DIGITAL A/V BLOCK (6/21)

UD8004

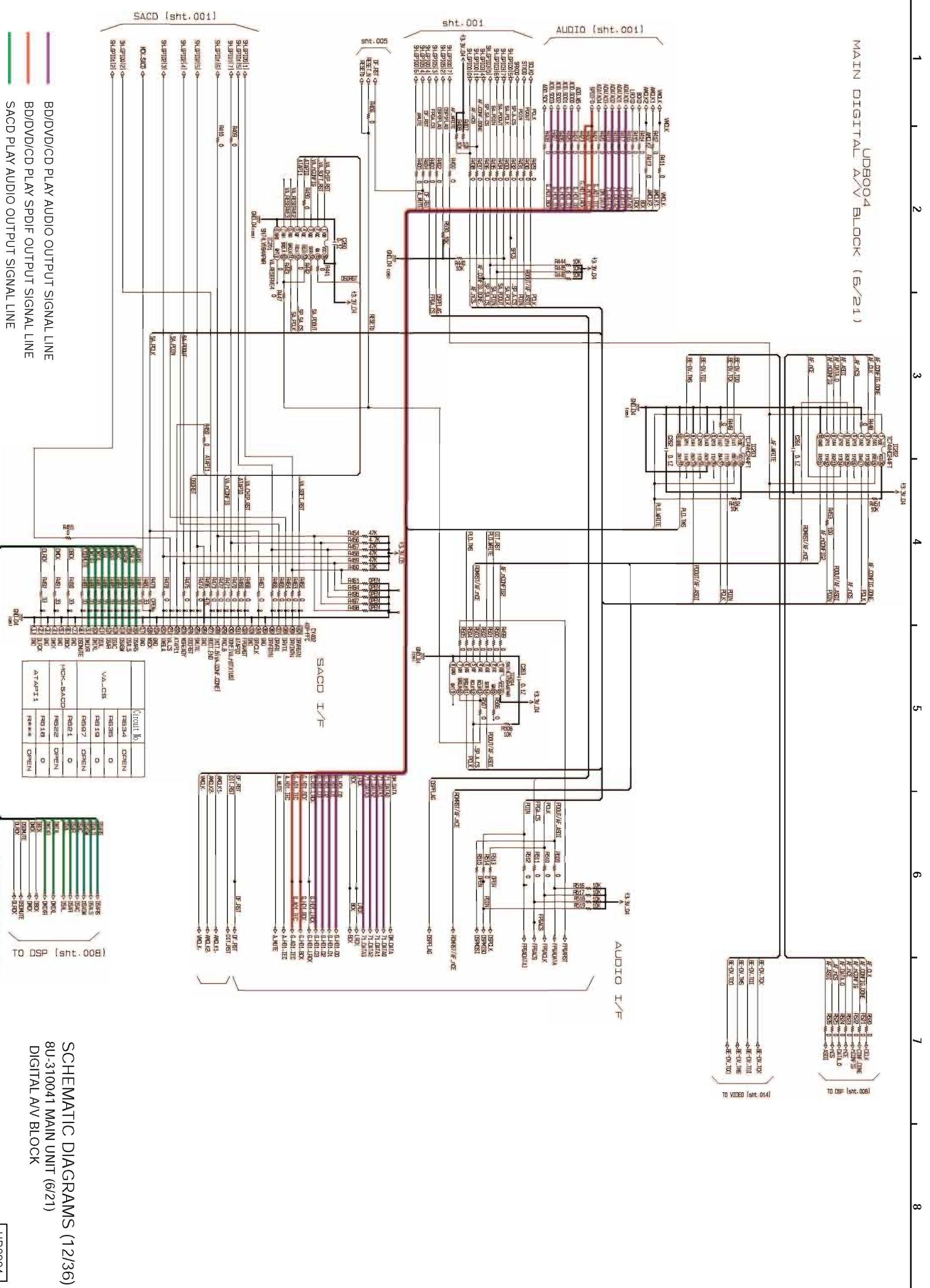

BD/DVD/CD PLAY AUDIO OUTPUT SIGNAL LINE  
 BD/DVD/CD PLAY SPDIF OUTPUT SIGNAL LINE  
 SACD PLAY AUDIO OUTPUT SIGNAL LINE

Circuit No.	State
RB34	OPEN
RB35	0
RB19	0
RB97	OPEN
RB21	0
RB22	OPEN
RB18	0
RB**	OPEN

Component	State
ISNR	0
ISNS	0
ISNSW	0
ISNC	0
ISRA	0
ISRL	0
ISRM	0
ISRN	0
ISRO	0
ISRS	0
ISRT	0
ISRU	0
ISRV	0
ISRW	0
ISRX	0
ISRY	0
ISRZ	0
ISRA1	0
ISRA2	0
ISRA3	0
ISRA4	0
ISRA5	0
ISRA6	0
ISRA7	0
ISRA8	0
ISRA9	0
ISRA10	0
ISRA11	0
ISRA12	0
ISRA13	0
ISRA14	0
ISRA15	0
ISRA16	0
ISRA17	0
ISRA18	0
ISRA19	0
ISRA20	0
ISRA21	0
ISRA22	0
ISRA23	0
ISRA24	0
ISRA25	0
ISRA26	0
ISRA27	0
ISRA28	0
ISRA29	0
ISRA30	0
ISRA31	0
ISRA32	0
ISRA33	0
ISRA34	0
ISRA35	0
ISRA36	0
ISRA37	0
ISRA38	0
ISRA39	0
ISRA40	0
ISRA41	0
ISRA42	0
ISRA43	0
ISRA44	0
ISRA45	0
ISRA46	0
ISRA47	0
ISRA48	0
ISRA49	0
ISRA50	0
ISRA51	0
ISRA52	0
ISRA53	0
ISRA54	0
ISRA55	0
ISRA56	0
ISRA57	0
ISRA58	0
ISRA59	0
ISRA60	0
ISRA61	0
ISRA62	0
ISRA63	0
ISRA64	0
ISRA65	0
ISRA66	0
ISRA67	0
ISRA68	0
ISRA69	0
ISRA70	0
ISRA71	0
ISRA72	0
ISRA73	0
ISRA74	0
ISRA75	0
ISRA76	0
ISRA77	0
ISRA78	0
ISRA79	0
ISRA80	0
ISRA81	0
ISRA82	0
ISRA83	0
ISRA84	0
ISRA85	0
ISRA86	0
ISRA87	0
ISRA88	0
ISRA89	0
ISRA90	0
ISRA91	0
ISRA92	0
ISRA93	0
ISRA94	0
ISRA95	0
ISRA96	0
ISRA97	0
ISRA98	0
ISRA99	0
ISRA100	0

SCHEMATIC DIAGRAMS (12/36)  
 8U-310041 MAIN UNIT (6/21)  
 DIGITAL A/V BLOCK

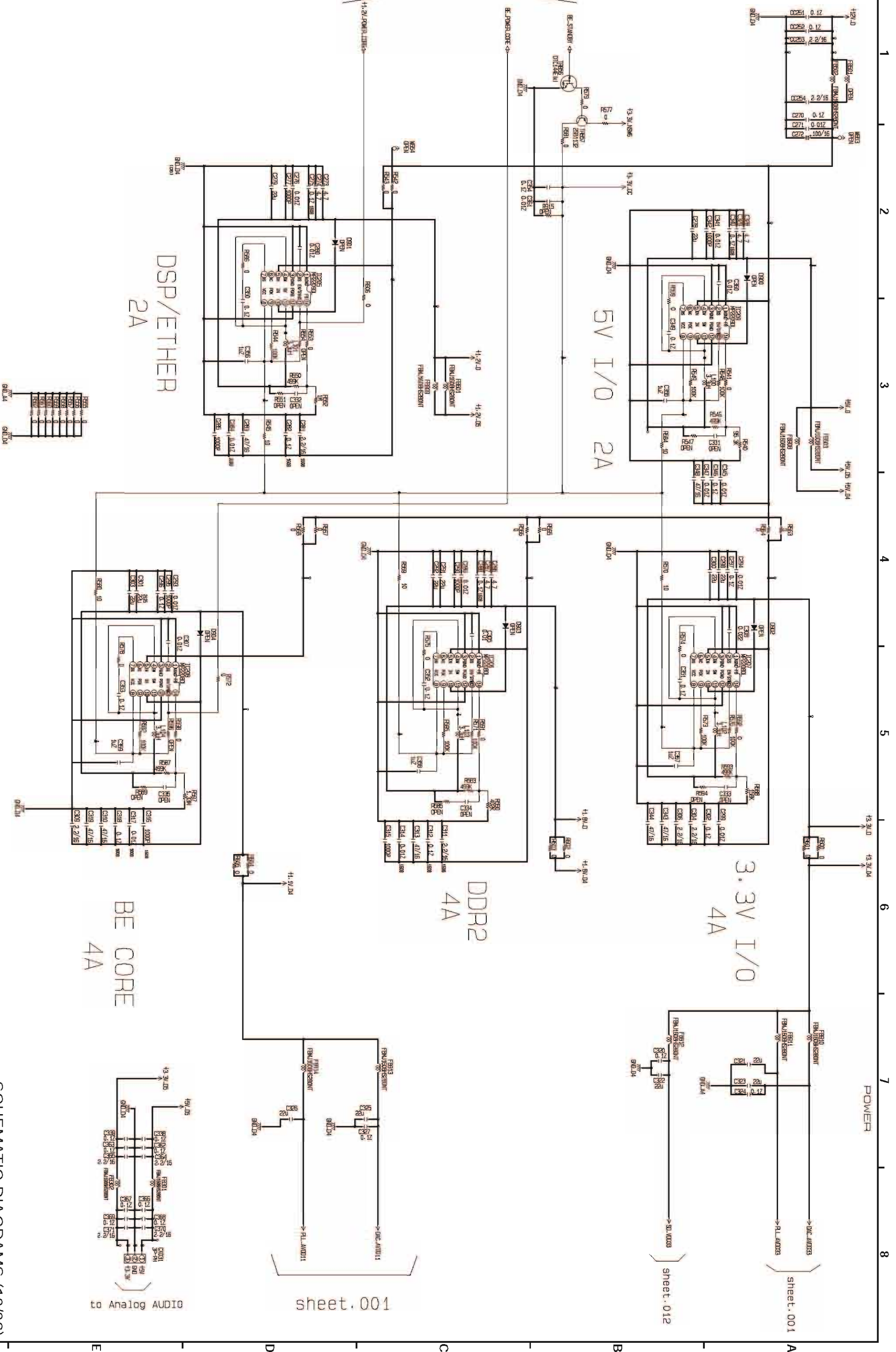

UD8004 MAIN BE POWER BLOCK (7/21)

FILE NAME: UD8004\_017\_007\_001

SCHEMATIC DIAGRAMS (13/36)  
8U-310041 MAIN UNIT (7/21)  
BE POWER BLOCK

UD8004

to Analog AUDIO

sheet.001

sheet.012

sheet.001

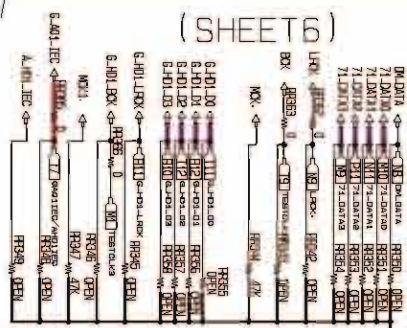
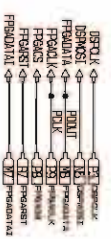

HDMI Audio Sheet.019

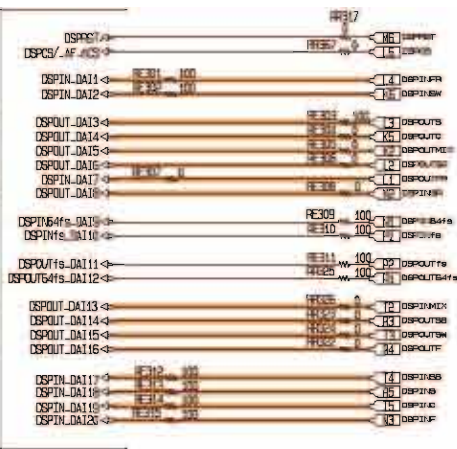

TO DSP 21367

	1	2	3	4	5	6	7	8	9	10	11	12	13	14	15	16
A	1	2	3	4	5	6	7	8	9	10	11	12	13	14	15	16
B	17	18	19	20	21	22	23	24	25	26	27	28	29	30	31	32
C	33	34	35	36	37	38	39	40	41	42	43	44	45	46	47	48
D	49	50	51	52	53	54	55	56	57	58	59	60	61	62	63	64
E	65	66	67	68	69	70	71	72	73	74	75	76	77	78	79	80
F	81	82	83	84	85	86	87	88	89	90	91	92	93	94	95	96
G	97	98	99	100	101	102	103	104	105	106	107	108	109	110	111	112
H	113	114	115	116	117	118	119	120	121	122	123	124	125	126	127	128
I	129	130	131	132	133	134	135	136	137	138	139	140	141	142	143	144
J	145	146	147	148	149	150	151	152	153	154	155	156	157	158	159	160
K	161	162	163	164	165	166	167	168	169	170	171	172	173	174	175	176
L	177	178	179	180	181	182	183	184	185	186	187	188	189	190	191	192
M	193	194	195	196	197	198	199	200	201	202	203	204	205	206	207	208
N	209	210	211	212	213	214	215	216	217	218	219	220	221	222	223	224
P	225	226	227	228	229	230	231	232	233	234	235	236	237	238	239	240
R	241	242	243	244	245	246	247	248	249	250	251	252	253	254	255	256
T	257	258	259	260	261	262	263	264	265	266	267	268	269	270	271	272

IC351 9201R2603N

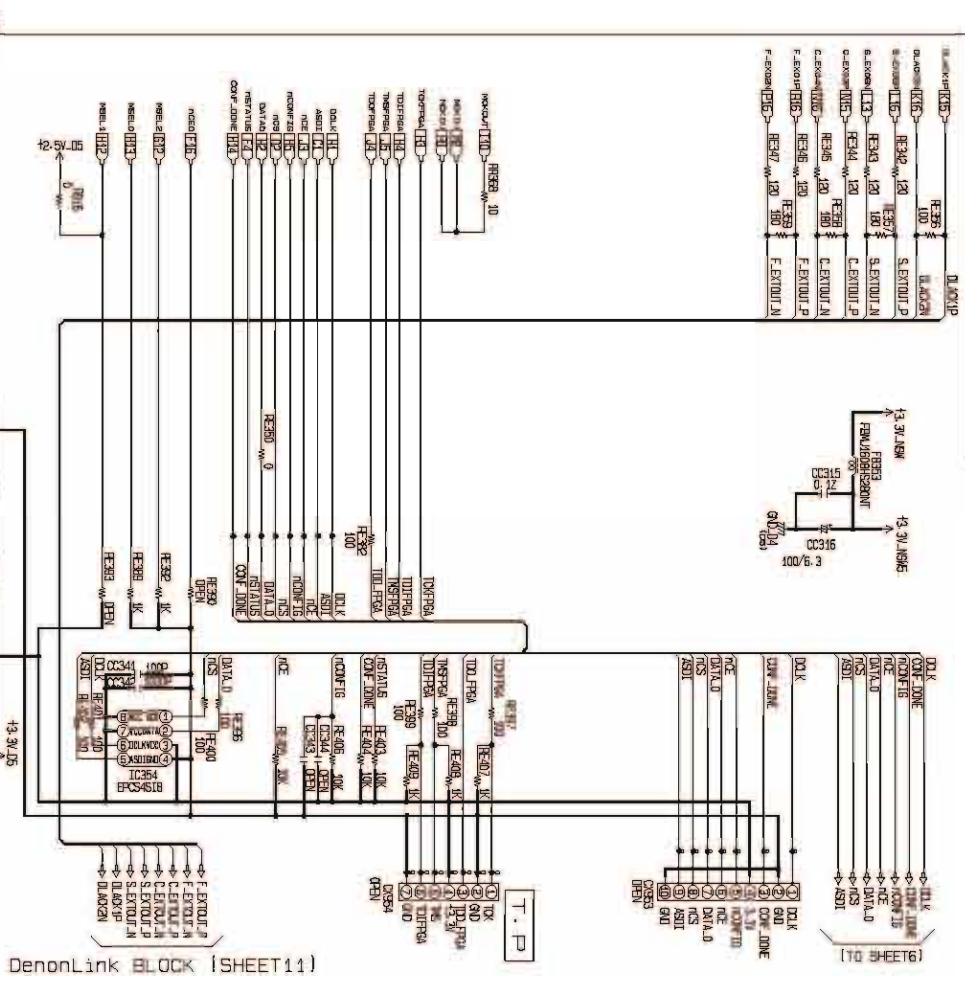
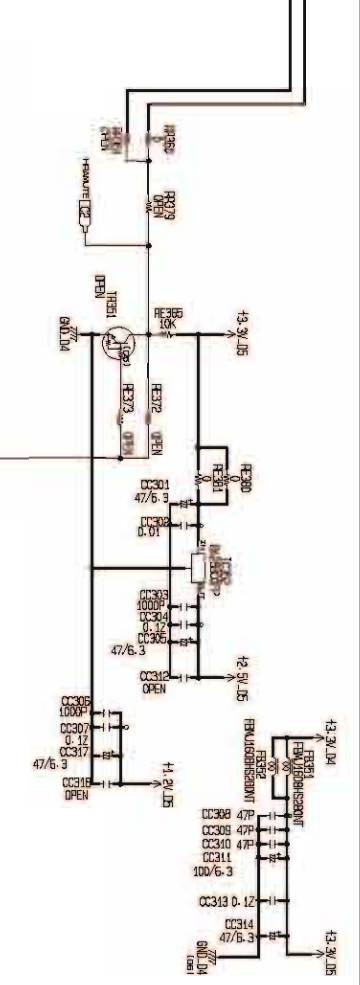

DenonLink BLOCK (SHEET11)

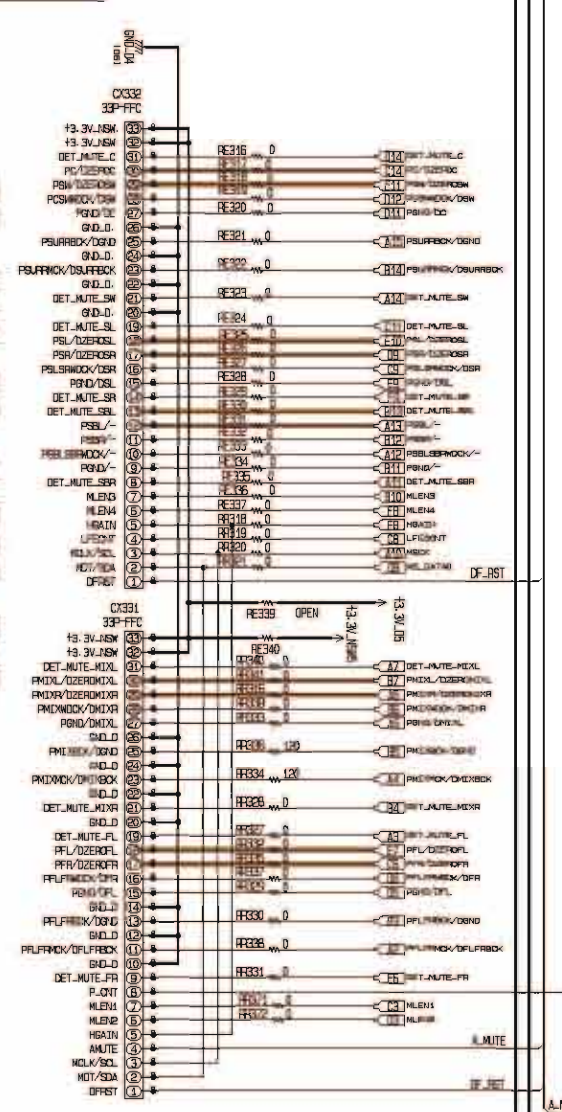

TO ANALOG AUDIO PWM

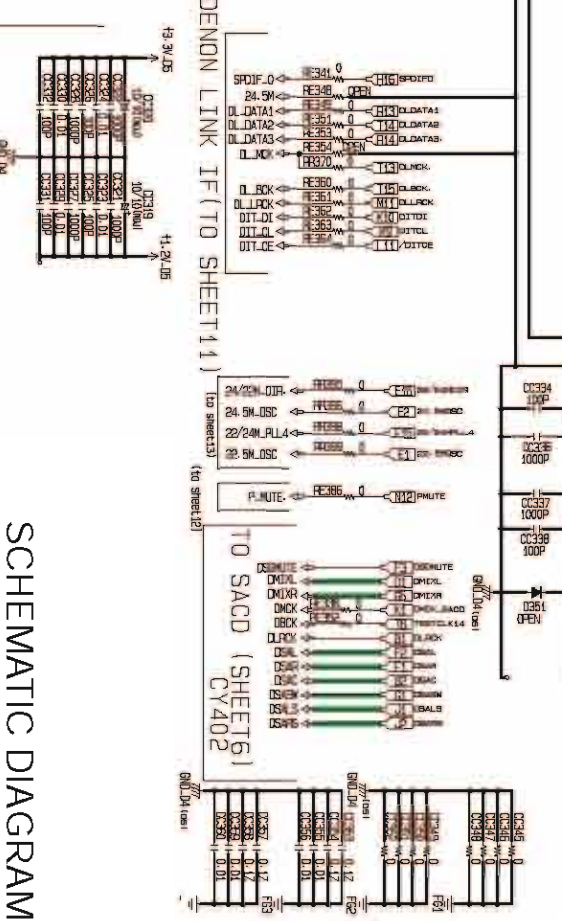

DENON LINK INT (TO SHEET11)

TO SACC (SHEETS 1)

TO CY402 (SHEETS 6)

SCHEMATIC DIAGRAMS (14/36)

8U-310041 MAIN UNIT (8/21)

ADVANCED AL24 PROCESSING BLOCK

UD8004

- BD/DVD/CD PLAY AUDIO OUTPUT SIGNAL LINE
- BD/DVD/CD PLAY SPDIF OUTPUT SIGNAL LINE
- HDMI AUDIO OUTPUT SIGNAL LINE
- ANALOG AUDIO OUTPUT SIGNAL LINE
- SACD PLAY AUDIO OUTPUT SIGNAL LINE
- BD/DVD/CD/SACD PLAY AUDIO OUTPUT SIGNAL LINE

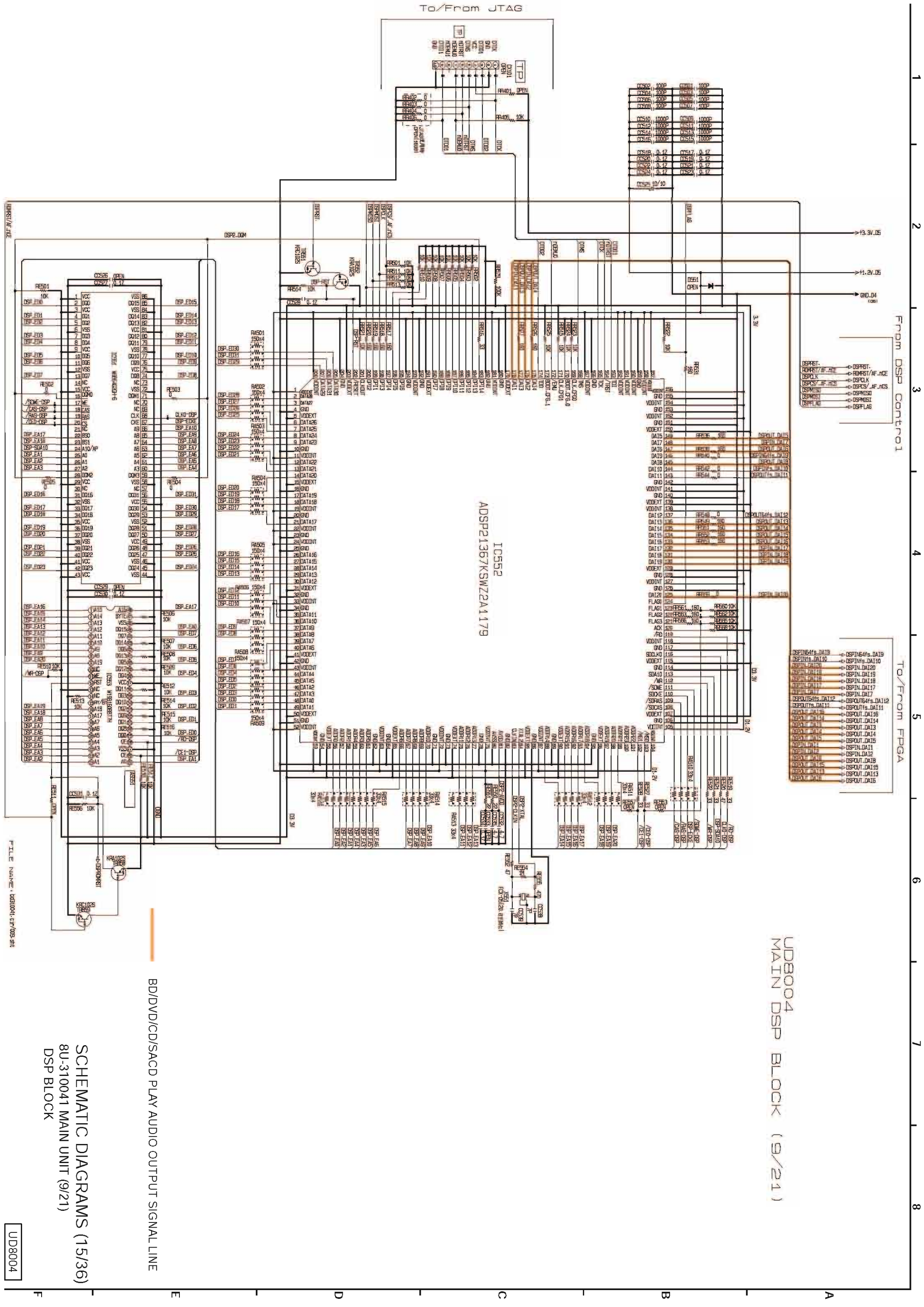

From DSP Control

To/From FPGA

UD8004  
MAIN DSP BLOCK (9/21)

BD/DVD/CD/SACD PLAY AUDIO OUTPUT SIGNAL LINE

SCHEMATIC DIAGRAMS (15/36)  
8U-310041 MAIN UNIT (9/21)  
DSP BLOCK

FILE NAME : 00310041\_097/003\_916

UD8004

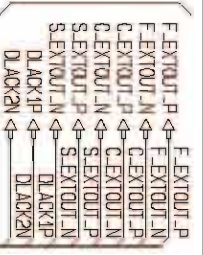

DENON LINK IF (TO SHEET14)

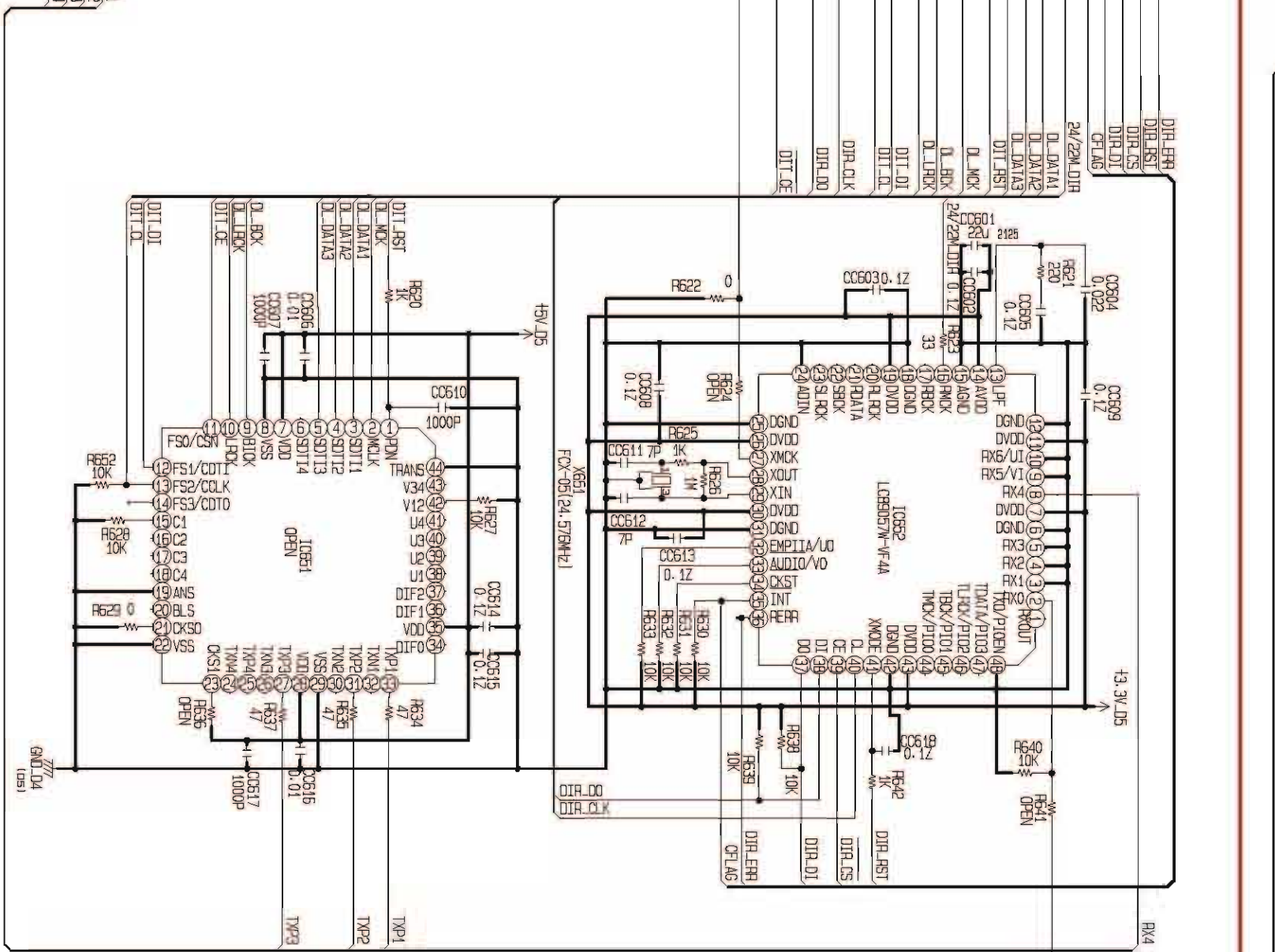

DIGITALOUT UNIT

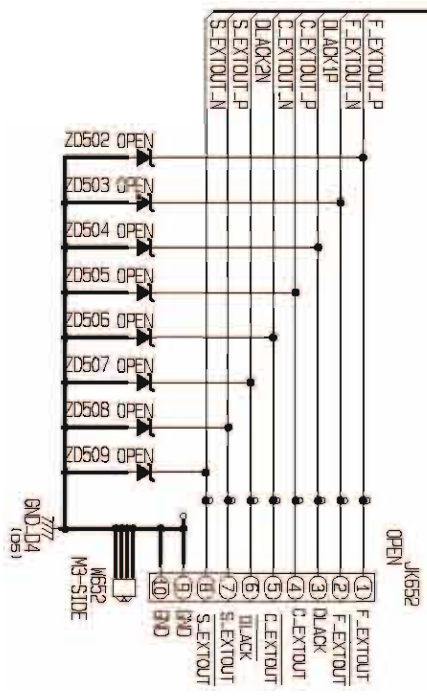
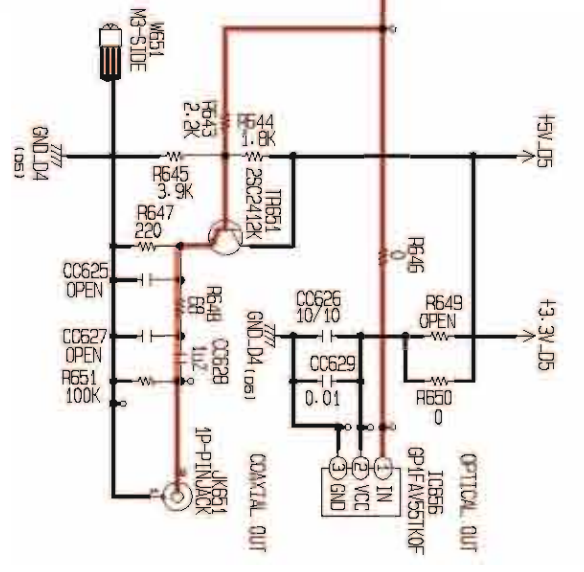

BD/DVD/CD PLAY SPDIF OUTPUT SIGNAL LINE

SCHEMATIC DIAGRAMS (16/36)  
 8U-310041 MAIN UNIT (10/21)  
 DENON LINK (DIT/DIR) BLOCK





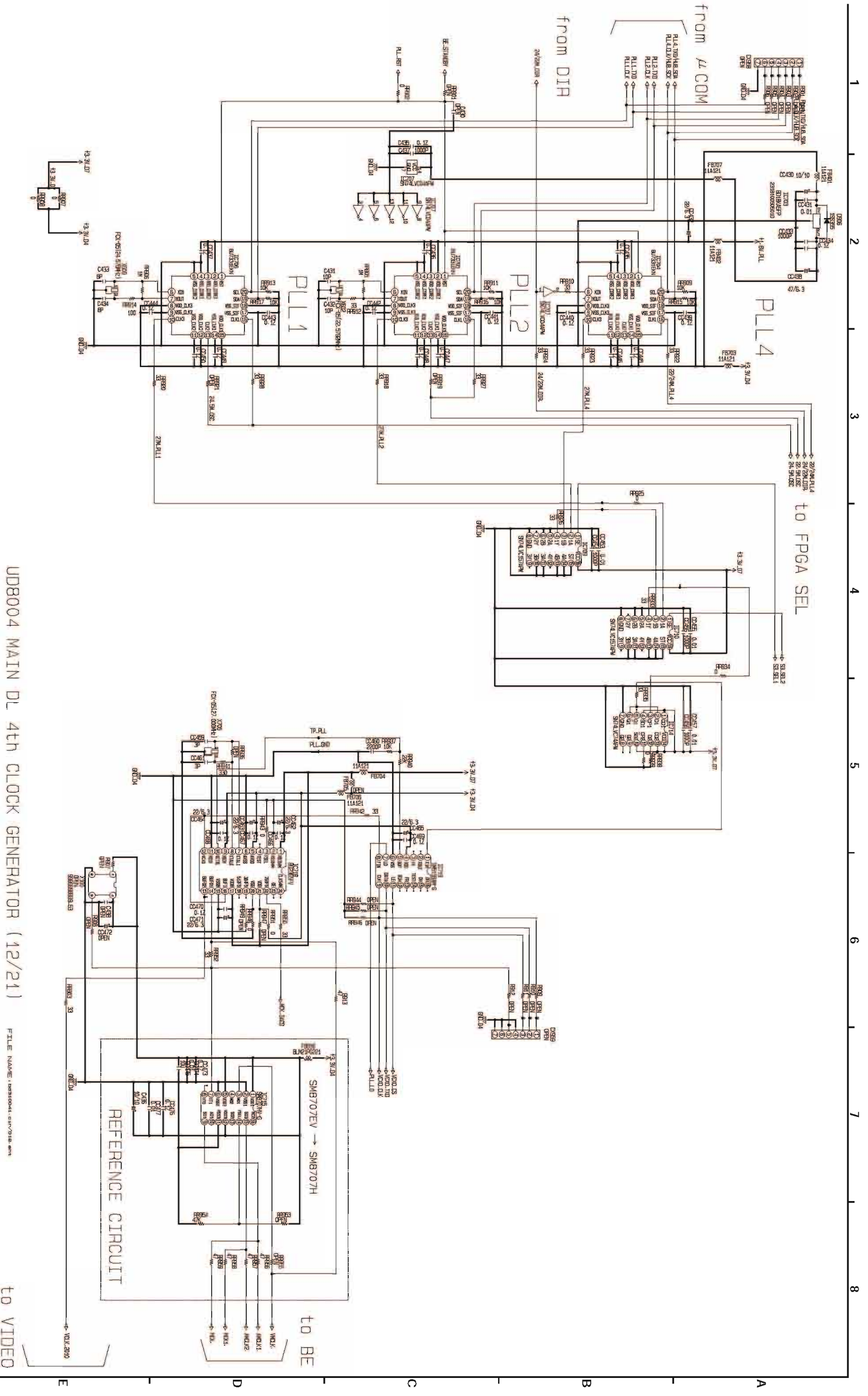

UD8004 MAIN DL 4th CLOCK GENERATOR (12/21)

FILE NAME: \MSR\0041.GRM\9181.BMT

to VIDEO

SCHEMATIC DIAGRAMS (18/36)  
 8U-310041 MAIN UNIT (12/21)  
 DL 4th CLOCK GENERATOR BLOCK

UTAG

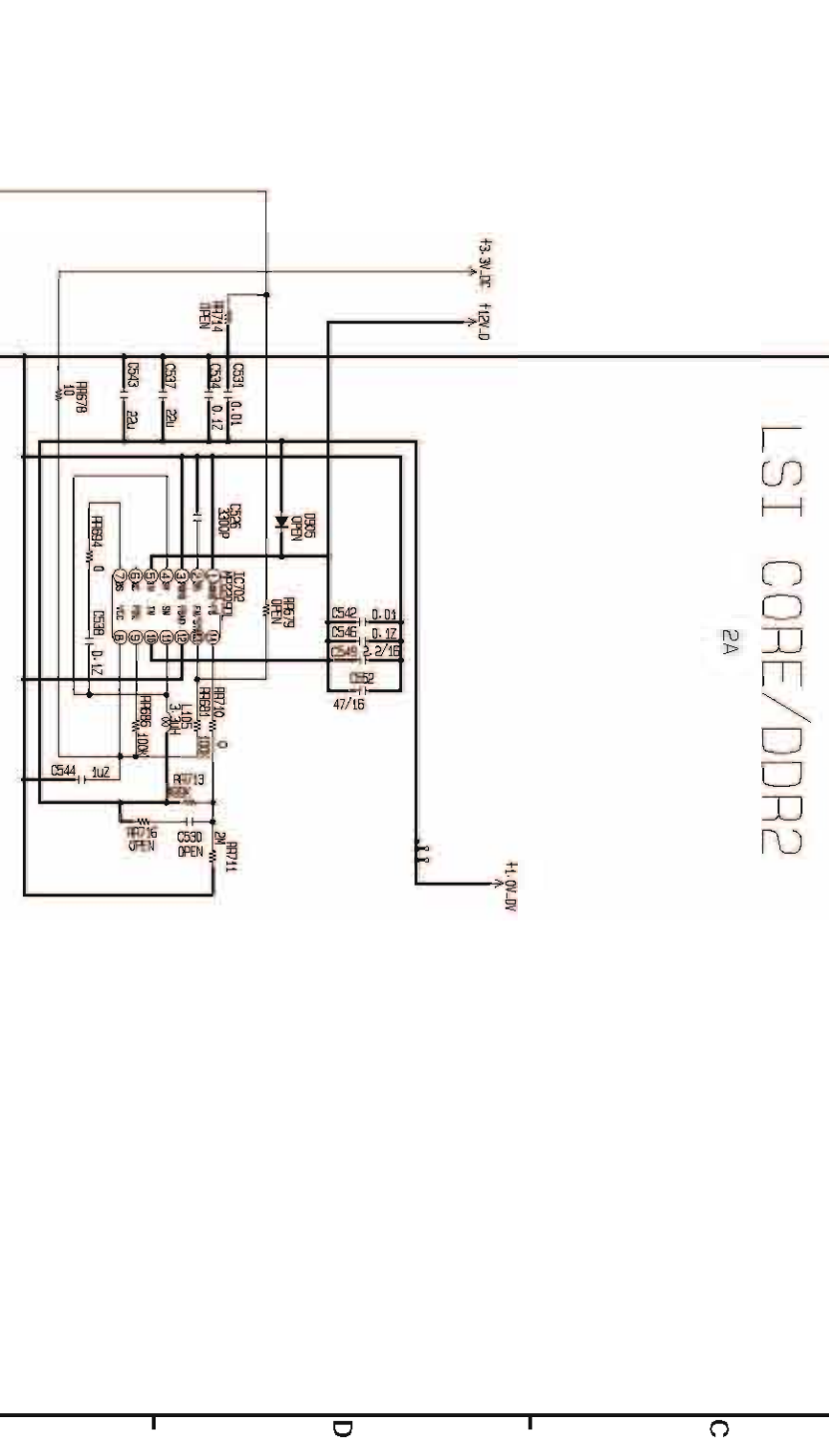
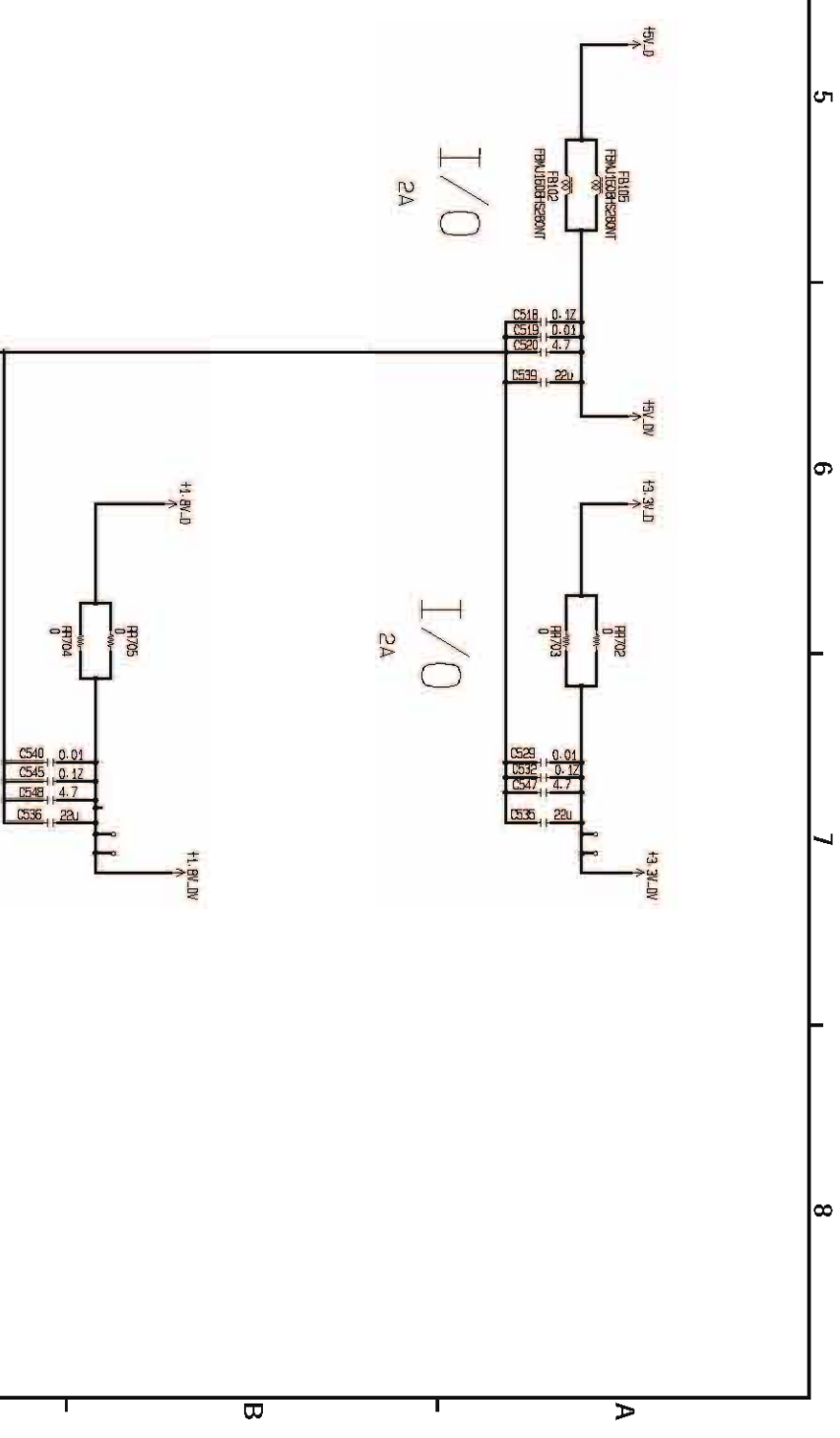
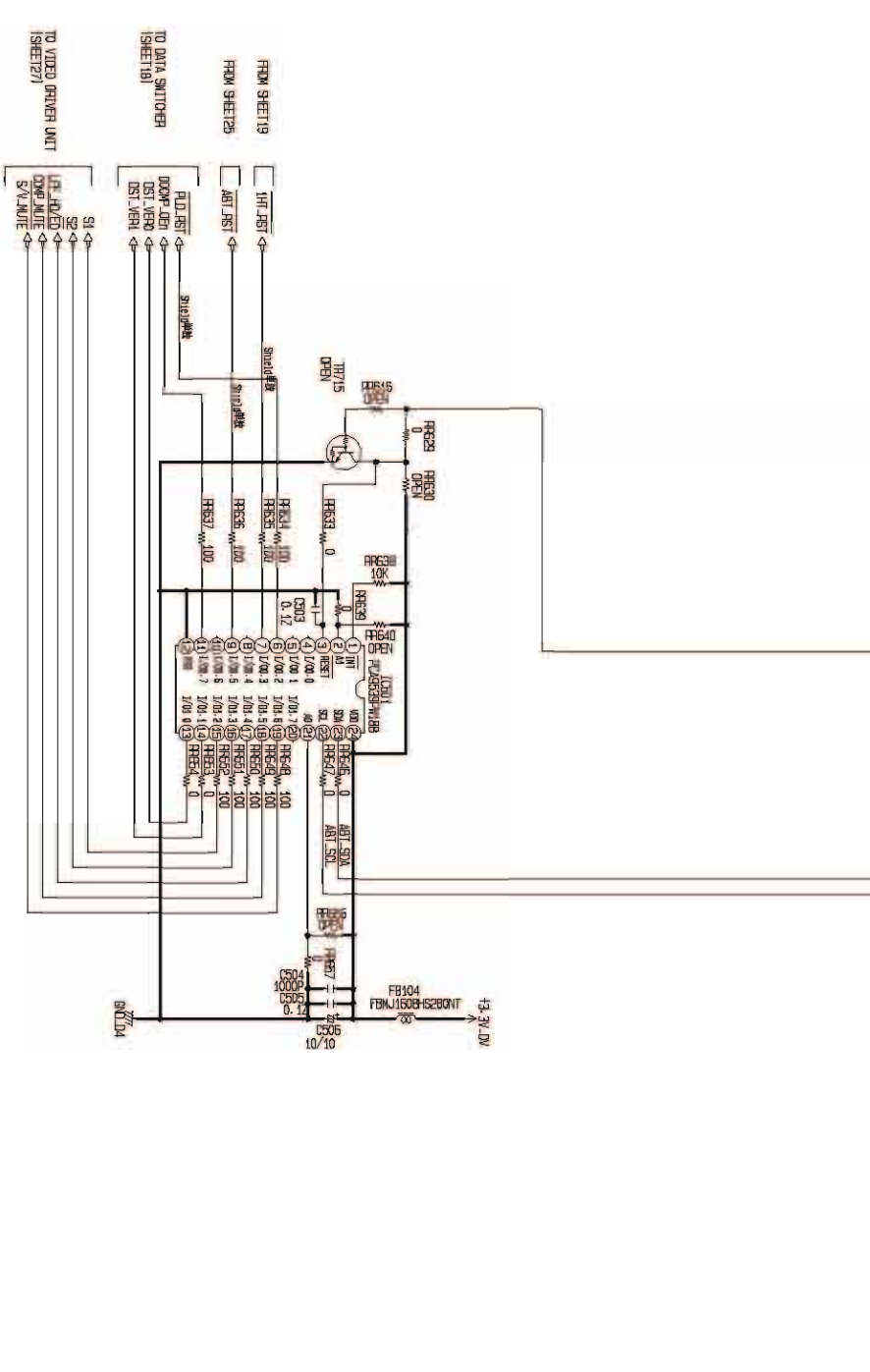
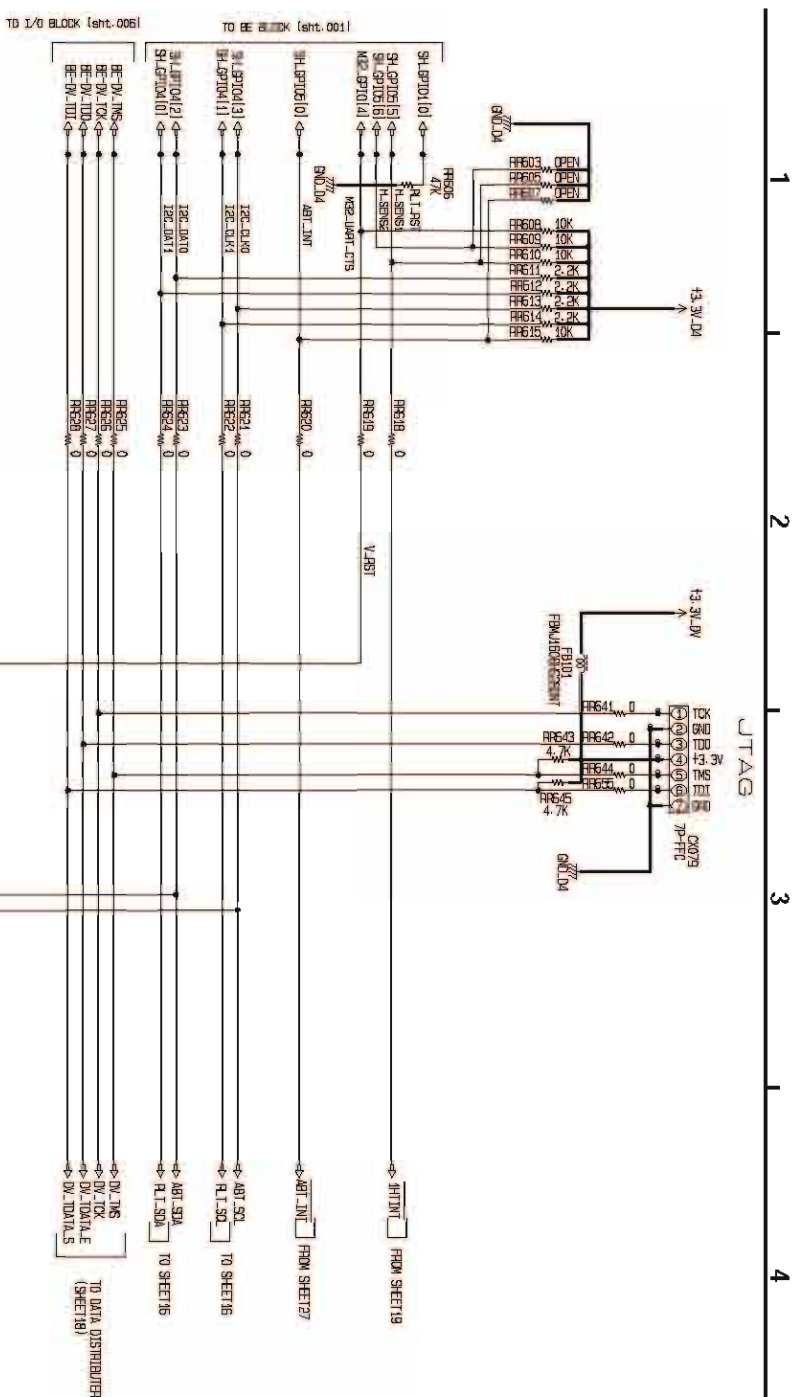

ABT2010 CORE  
2A

SCHEMATIC DIAGRAMS (19/36)  
8U-310041 MAIN UNIT (13/21)  
VIDEO I/O POWER BLOCK

UD8004 MAIN VIDEO I/O POWER UNIT (13/21)

FILE NAME : UD8004\_517/03\_81C

UD8004



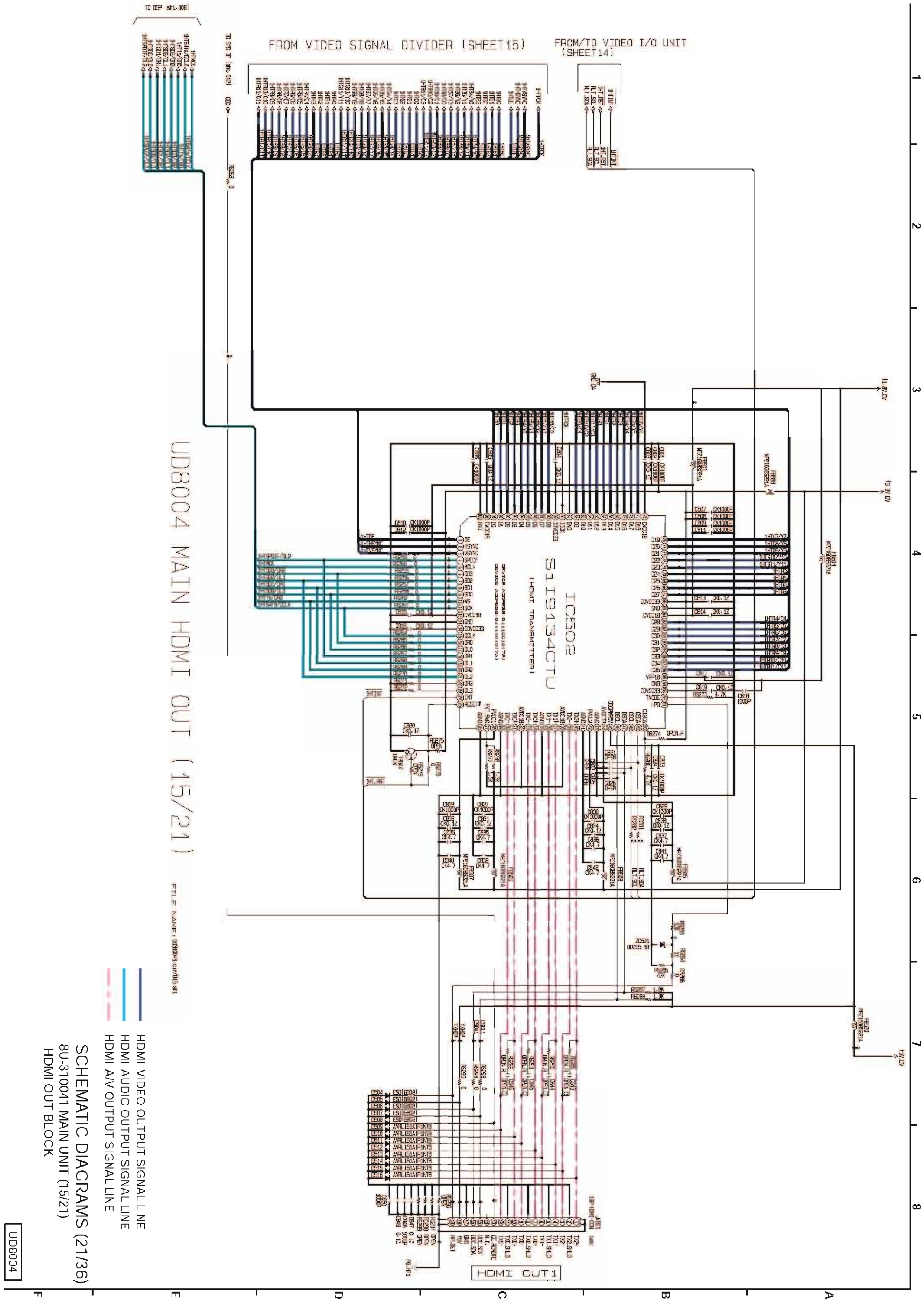

UD8004 MAIN HDMI OUT (15/21)

FILE NAME: UD8004\_C01/015.SMT

- HDMI VIDEO OUTPUT SIGNAL LINE
- HDMI AUDIO OUTPUT SIGNAL LINE
- HDMI AV OUTPUT SIGNAL LINE

SCHEMATIC DIAGRAMS (21/36)  
 8U-310041 MAIN UNIT (15/21)  
 HDMI OUT BLOCK

FROM DATA DISTRIBUTOR (SHEET2)

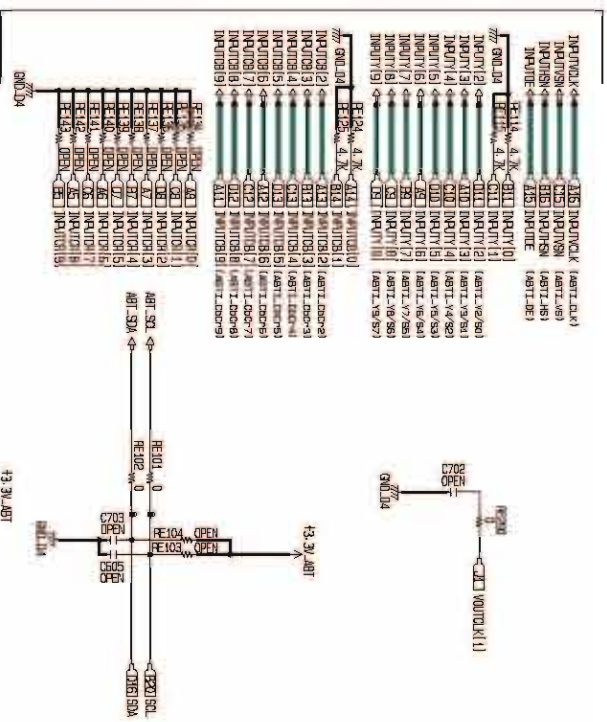

TO VIDEO SIGNAL DIVIDER (SHEET10)

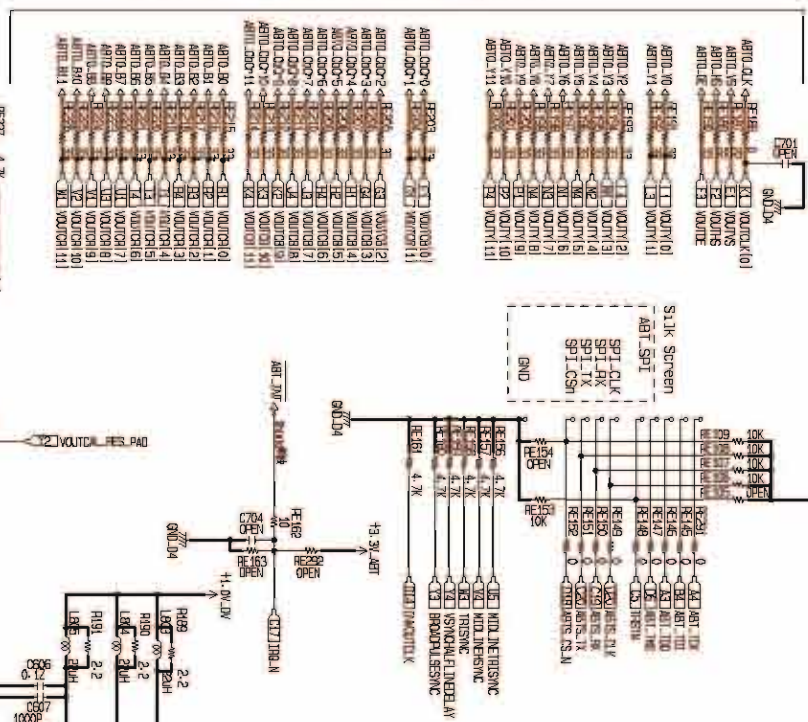

FROM CLOCK GENERATOR (SHEET13)

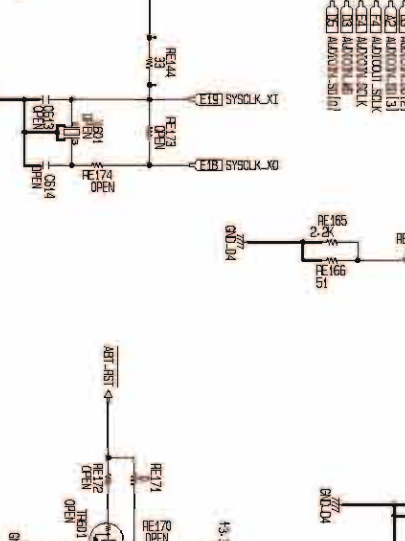

A	1	2	3	4	5	6	7	8	9	10	11	12	13	14	15	16	17	18	19	20
B	1	2	3	4	5	6	7	8	9	10	11	12	13	14	15	16	17	18	19	20
C	1	2	3	4	5	6	7	8	9	10	11	12	13	14	15	16	17	18	19	20
D	1	2	3	4	5	6	7	8	9	10	11	12	13	14	15	16	17	18	19	20
E	1	2	3	4	5	6	7	8	9	10	11	12	13	14	15	16	17	18	19	20
F	1	2	3	4	5	6	7	8	9	10	11	12	13	14	15	16	17	18	19	20
G	1	2	3	4	5	6	7	8	9	10	11	12	13	14	15	16	17	18	19	20
H	1	2	3	4	5	6	7	8	9	10	11	12	13	14	15	16	17	18	19	20
I	1	2	3	4	5	6	7	8	9	10	11	12	13	14	15	16	17	18	19	20
J	1	2	3	4	5	6	7	8	9	10	11	12	13	14	15	16	17	18	19	20
K	1	2	3	4	5	6	7	8	9	10	11	12	13	14	15	16	17	18	19	20
L	1	2	3	4	5	6	7	8	9	10	11	12	13	14	15	16	17	18	19	20
M	1	2	3	4	5	6	7	8	9	10	11	12	13	14	15	16	17	18	19	20
N	1	2	3	4	5	6	7	8	9	10	11	12	13	14	15	16	17	18	19	20
P	1	2	3	4	5	6	7	8	9	10	11	12	13	14	15	16	17	18	19	20
Q	1	2	3	4	5	6	7	8	9	10	11	12	13	14	15	16	17	18	19	20
R	1	2	3	4	5	6	7	8	9	10	11	12	13	14	15	16	17	18	19	20
T	1	2	3	4	5	6	7	8	9	10	11	12	13	14	15	16	17	18	19	20
U	1	2	3	4	5	6	7	8	9	10	11	12	13	14	15	16	17	18	19	20
V	1	2	3	4	5	6	7	8	9	10	11	12	13	14	15	16	17	18	19	20
W	1	2	3	4	5	6	7	8	9	10	11	12	13	14	15	16	17	18	19	20
Y	1	2	3	4	5	6	7	8	9	10	11	12	13	14	15	16	17	18	19	20

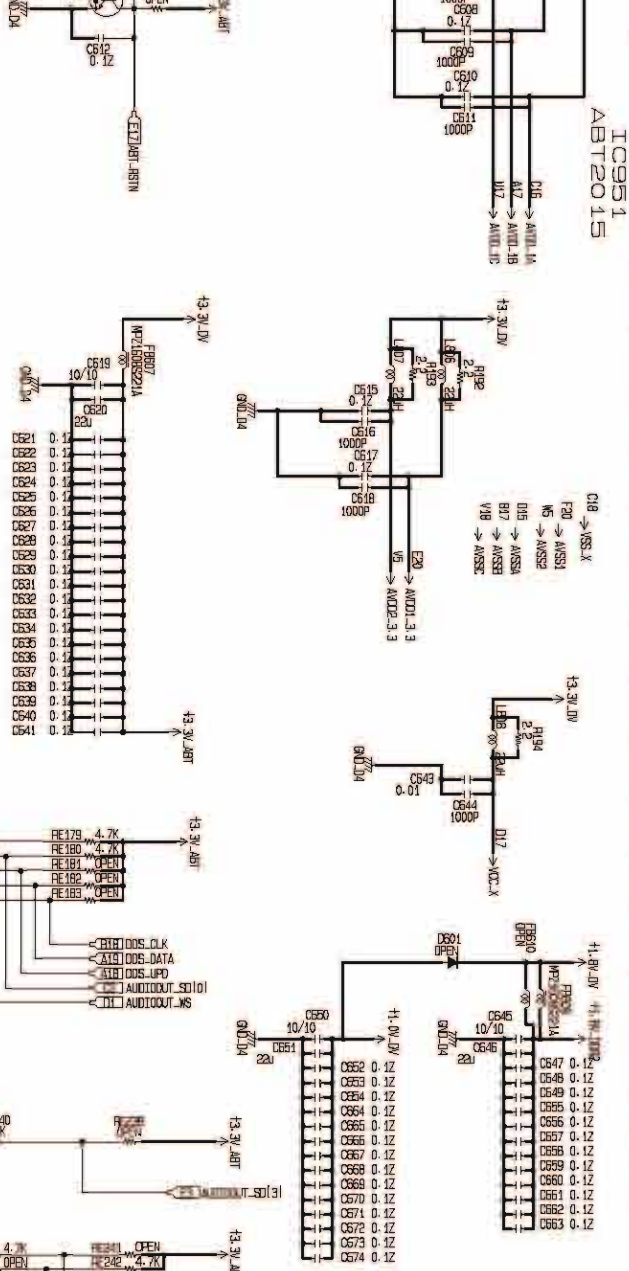

UD8004 MAIN ABT2010 I/P & SCALER for HDMI/Component (16/21)

FILE NAME : UD8004\_C17/016\_S11

- COMPONENT, HDMI VIDEO OUTPUT SIGNAL LINE (IC951 INPUT)
- COMPONENT, HDMI VIDEO OUTPUT SIGNAL LINE (IC951 OUTPUT)

FROM/TO DDR2 (SHEET9)

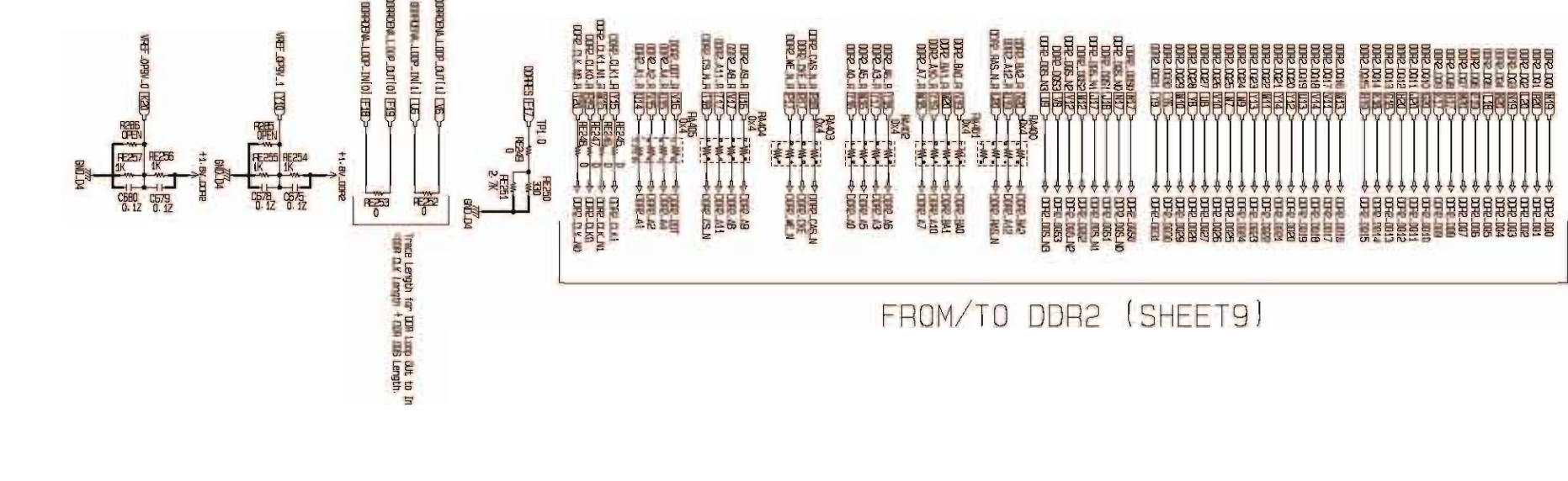

SCHEMATIC DIAGRAMS (22/36)  
8U-310041 MAIN UNIT (16/21)  
ABT 2015 I/P & SCALER  
for HDMI/Component Block

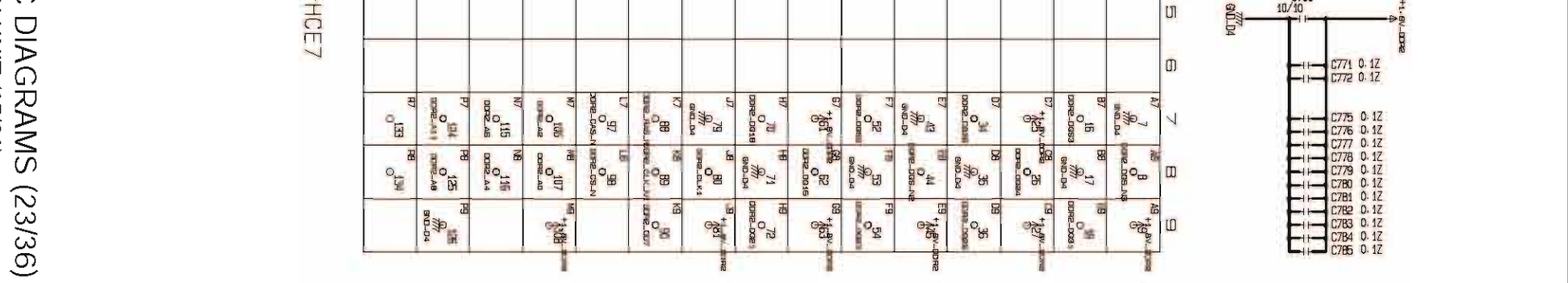
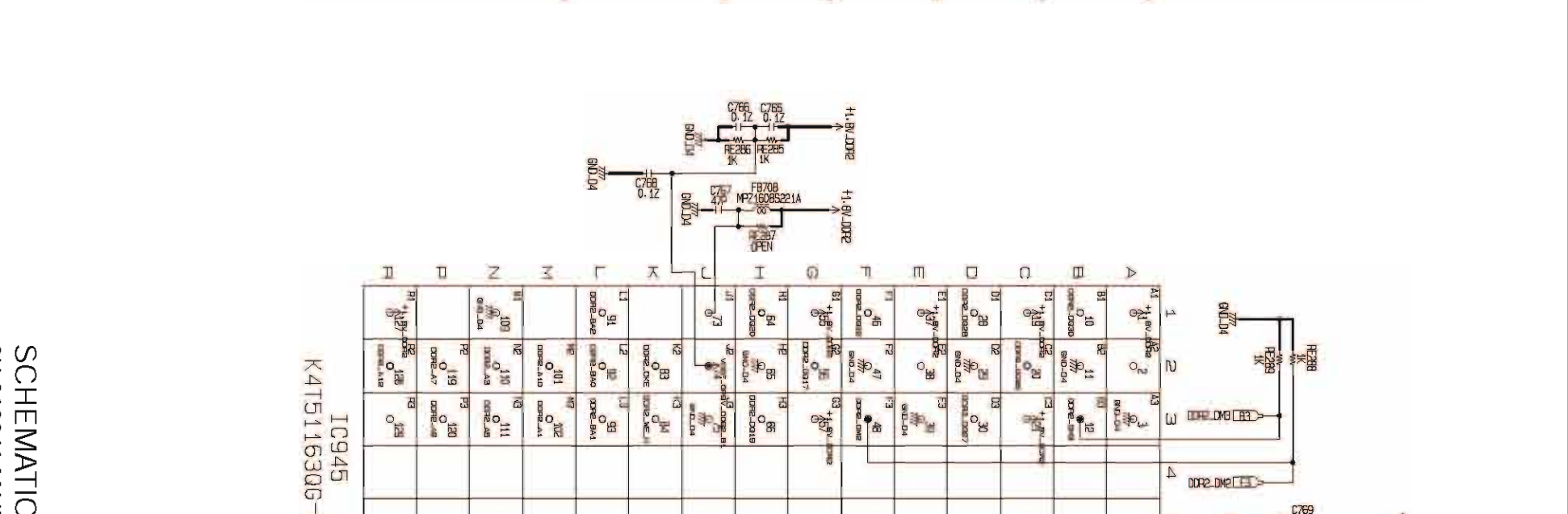
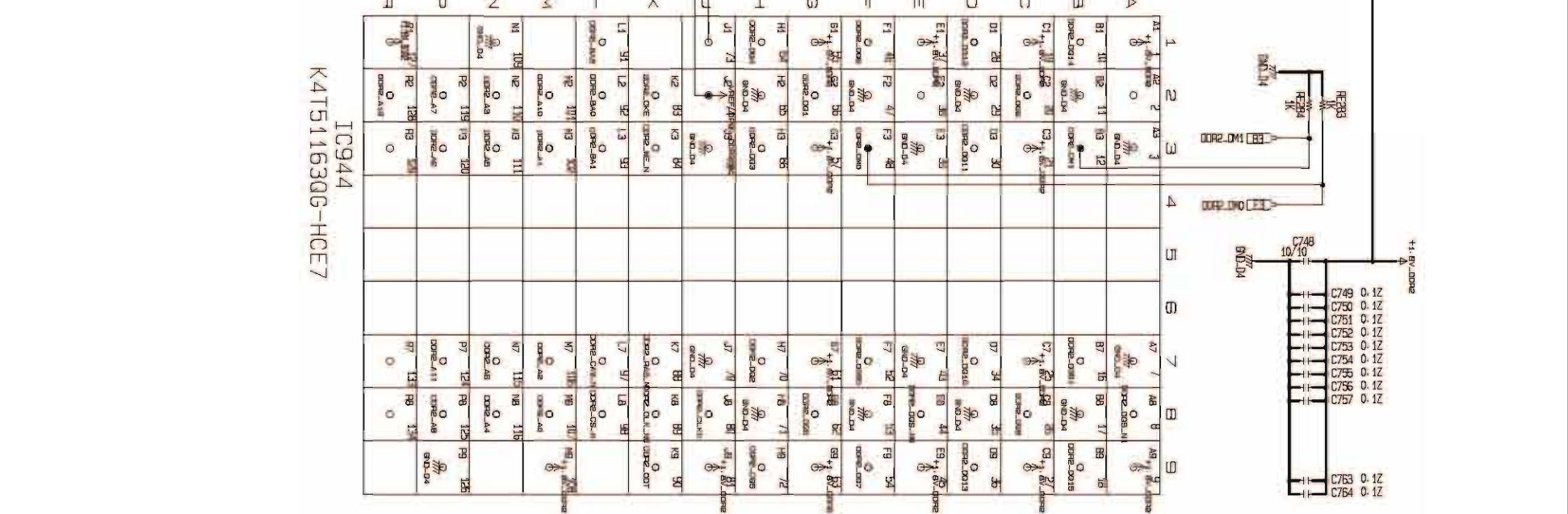
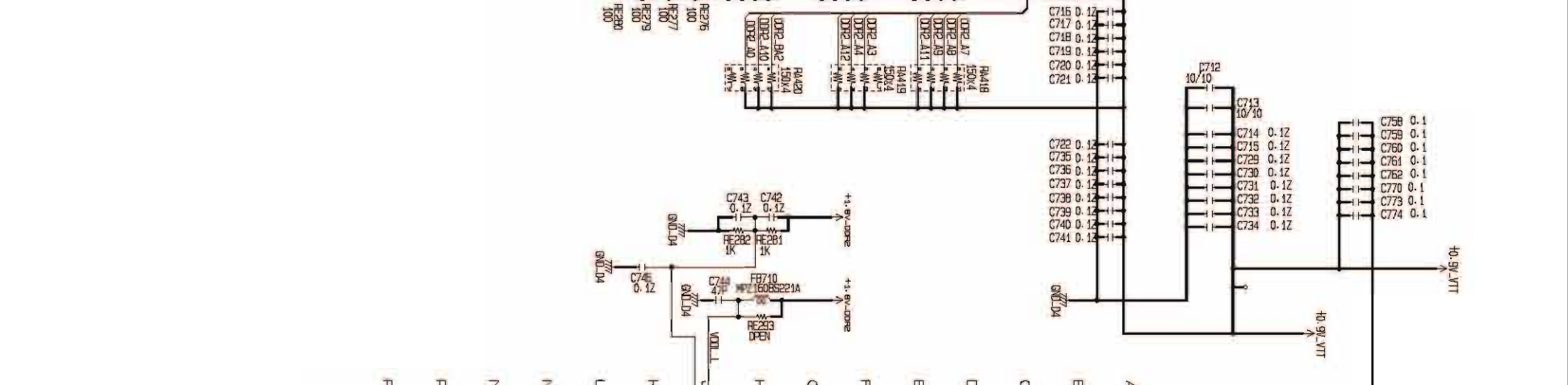
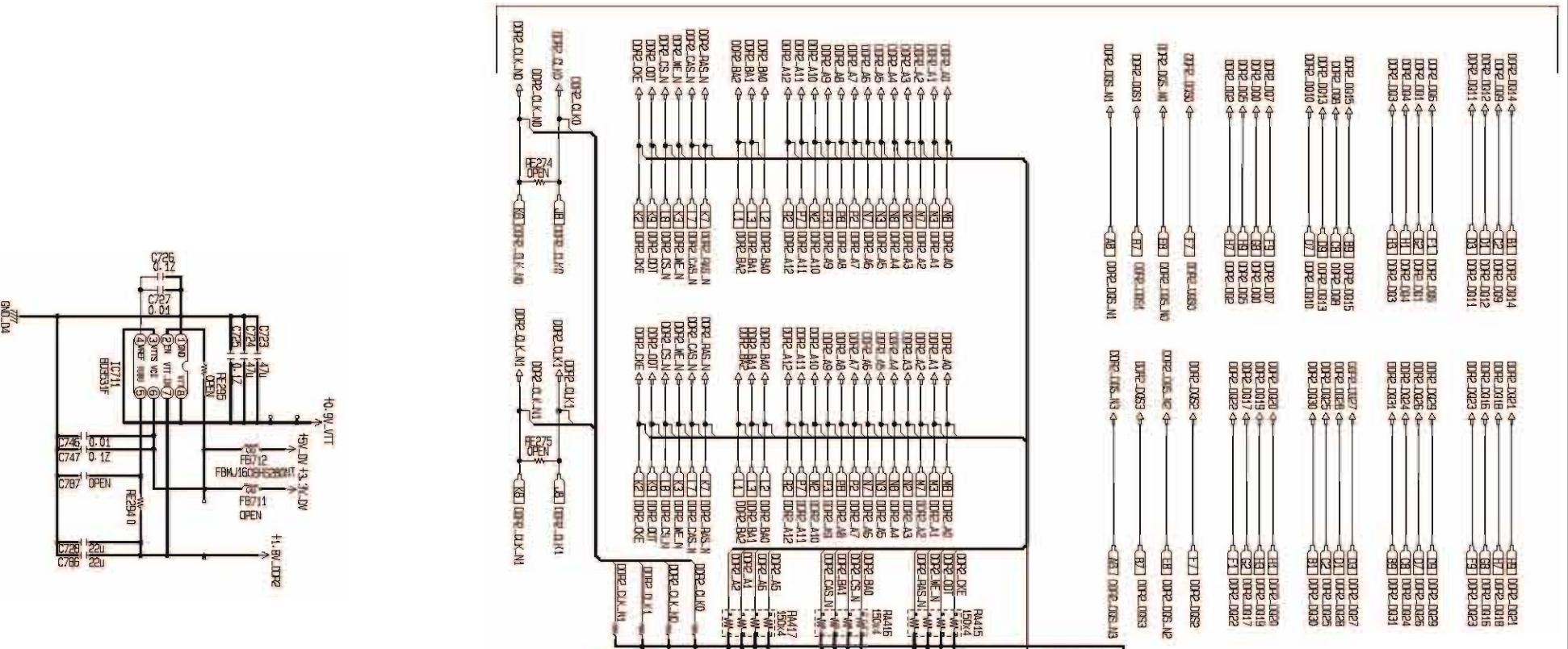

IC944  
K4T511630G-HCE7

IC945  
K4T511630G-HCE7

UD8004 MAIN DDR2 X 2 (800) for ABT2010 (17/21)

SCHEMATIC DIAGRAMS (23/36)  
8U-310041 MAIN UNIT (17/21)  
DDR2 X 2(800) for ABT2015 BLOCK











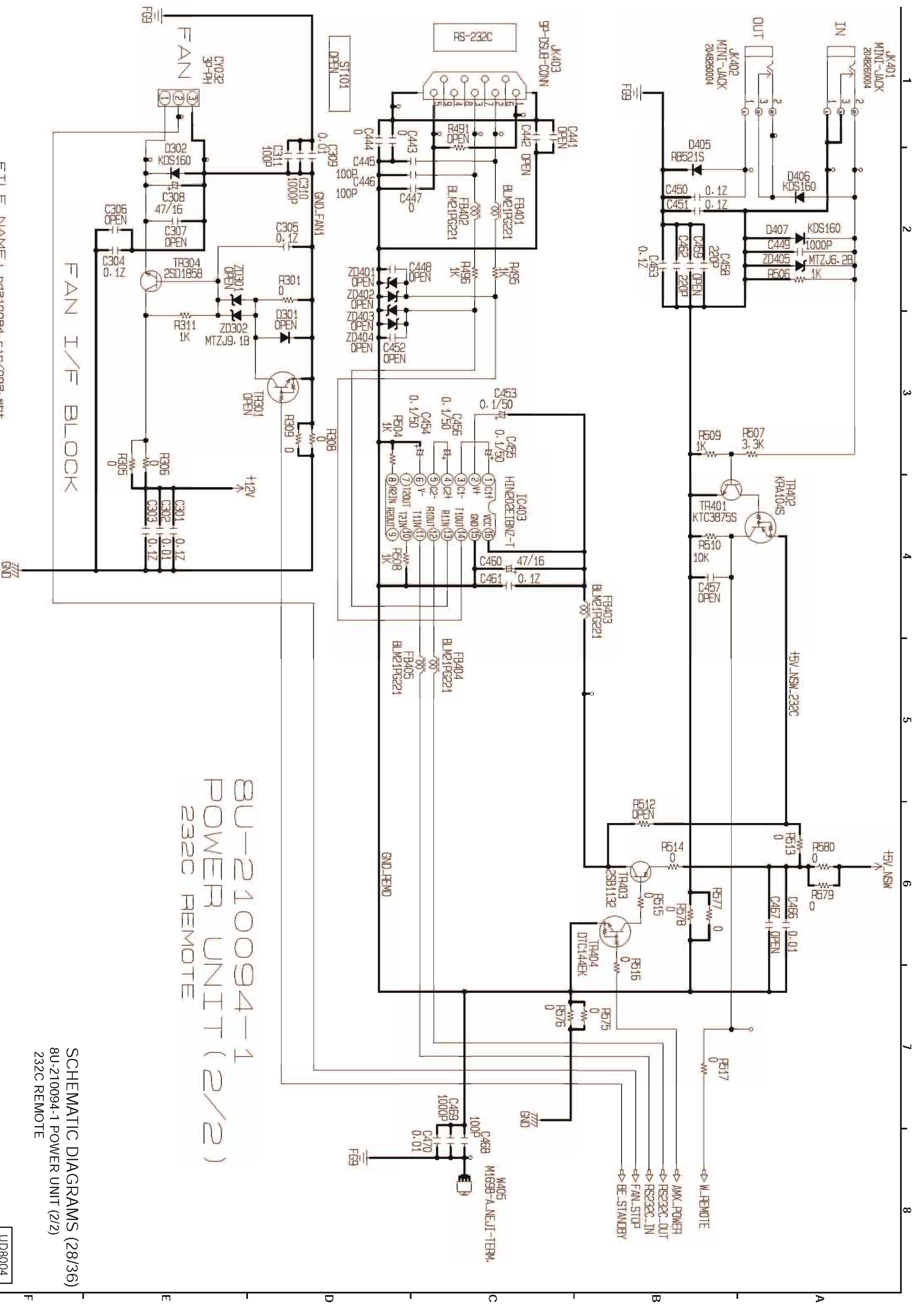

8U-210094-1  
 POWER UNIT (2/2)  
 232C REMOTE

SCHEMATIC DIAGRAMS (28/36)  
 8U-210094-1 POWER UNIT (2/2)  
 232C REMOTE

FILE NAME: bd210094.cir/002.sht

UD8004



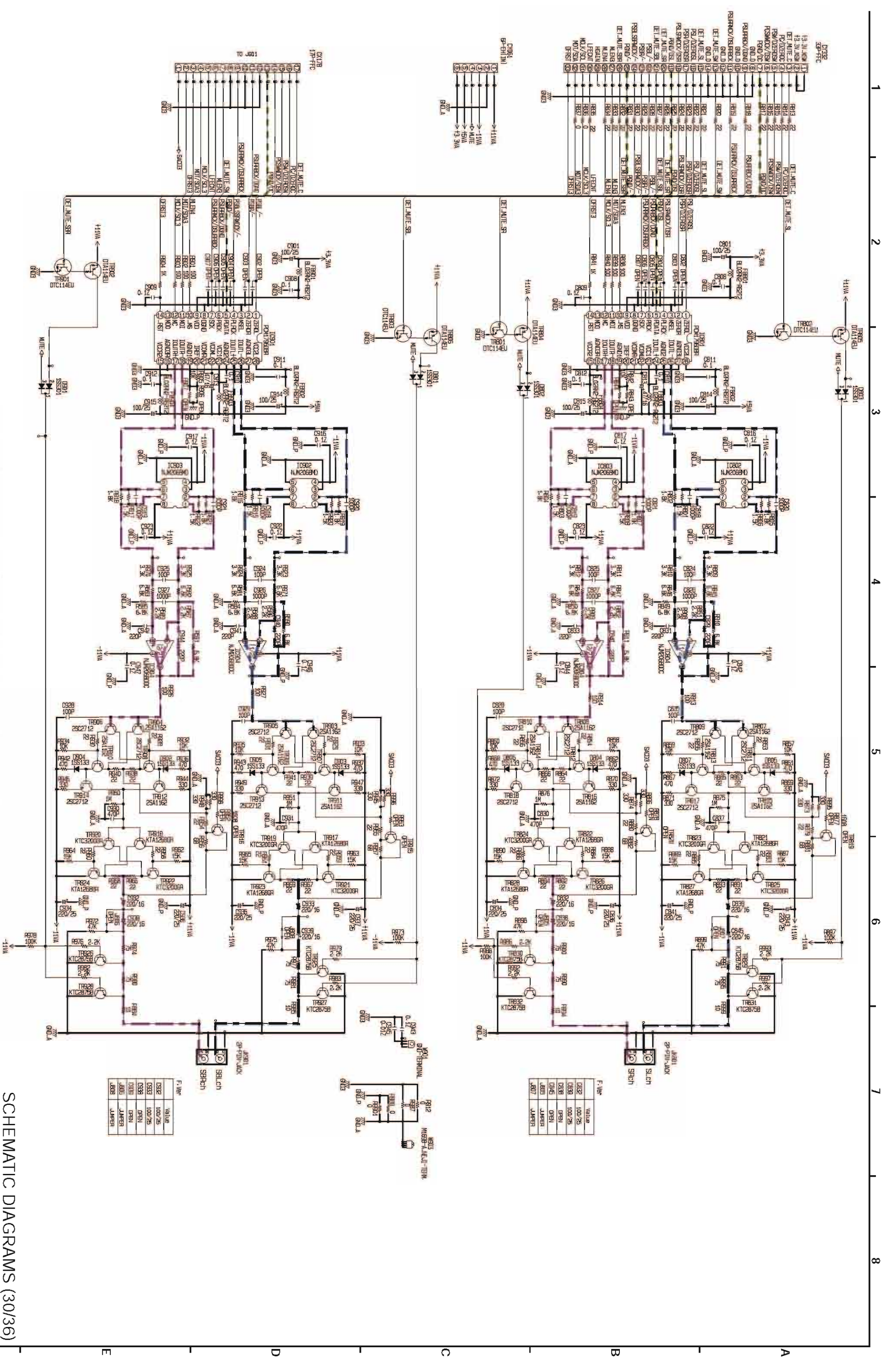

--- DIGITAL SIGNAL LINE  
--- ANALOG SIGNAL LINE (L/F/LC/S/USBL)  
--- ANALOG SIGNAL LINE (R/F/R/S/W/SR/SBR)

# 8U-210094-3 AUDIO3 UNIT

F. Ref	Value
D22	100/25
D33	100/25
D38	OPEN
D39	OPEN
J80	JUMPER
J85	JUMPER

F. Ref	Value
D22	100/25
D38	100/25
D39	OPEN
D46	OPEN
J80	JUMPER
J87	JUMPER

SCHEMATIC DIAGRAMS (30/36)  
8U-210094-3 AUDIO3 UNIT

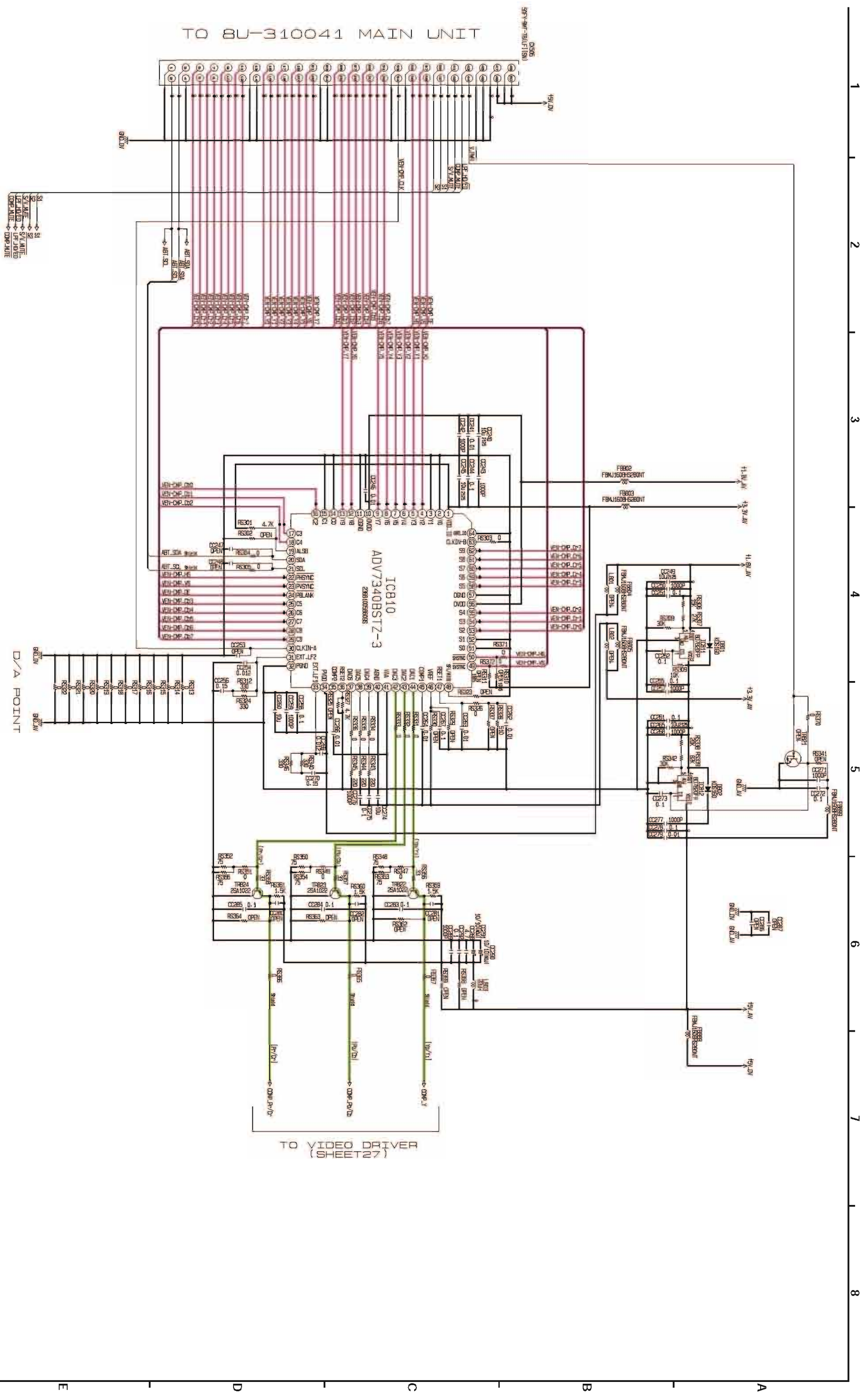

TO BU-210041 MAIN UNIT

TO VIDEO DRIVER (SHEET 27)

BU-210095-1 (1/3)  
VIDEO ENCODER for COMPONENT

COMPONENT VIDEO OUTPUT SIGNAL LINE (IC810 INPUT)  
COMPONENT VIDEO OUTPUT SIGNAL LINE (IC801 OUTPUT)

SCHEMATIC DIAGRAMS (31/36)  
BU-210095-1 ANALOG VIDEO UNIT (1/3)  
VIDEO ENCODER for COMPONENT

FILE NAME: D210095.CIV/01.91E

UD8004

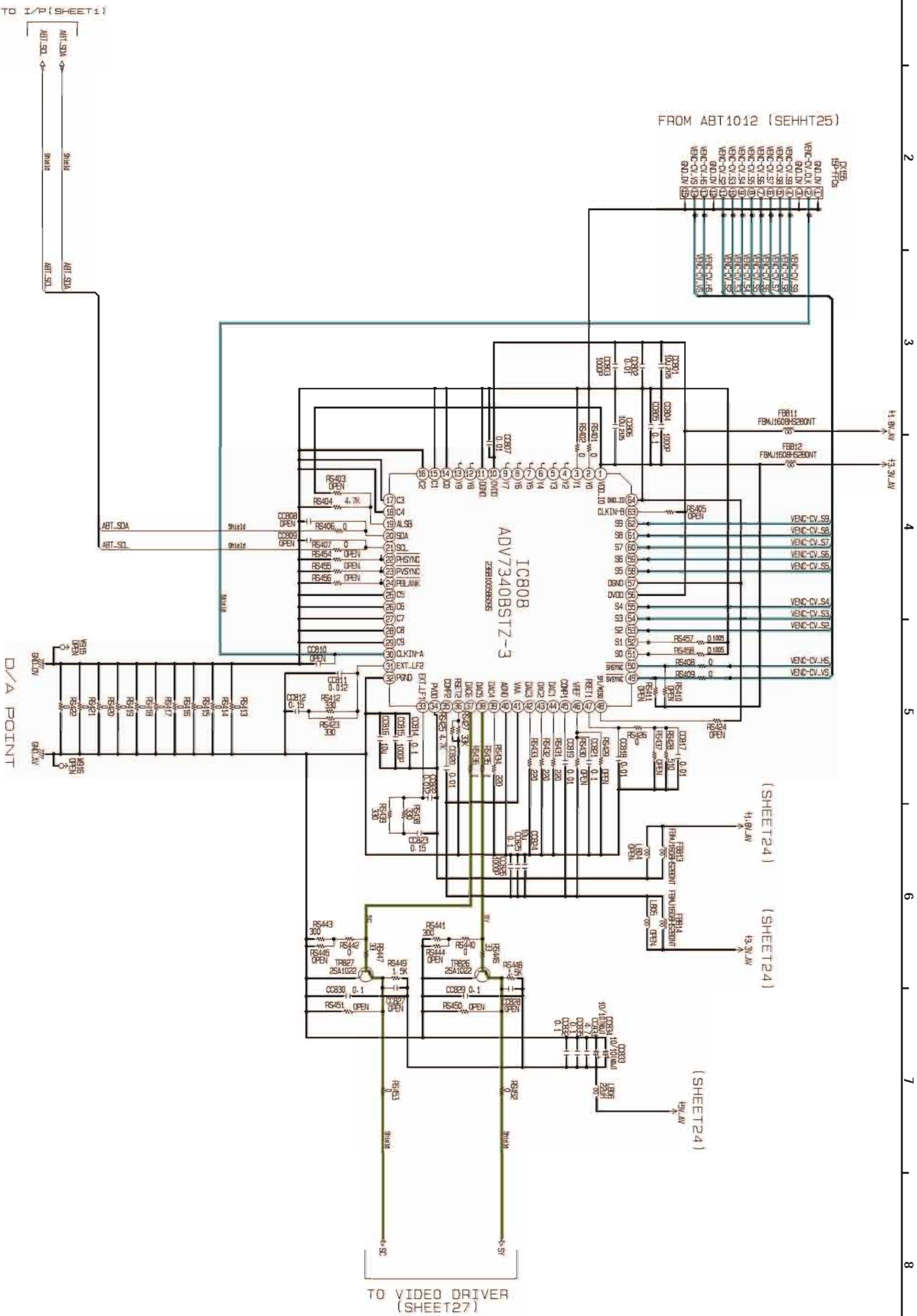

FROM ABT1012 (SEHHT25)

TO I/P (SHEET 1)

TO VIDEO DRIVER (SHEET 27)

8U-210095-1 (2/3)

VIDEO ENCODER for Y/C CVBS

VIDEO OUT, S-VIDEO OUT VIDEO OUTPUT SIGNAL LINE (IC808 INPUT)  
 VIDEO OUT, S-VIDEO OUT VIDEO OUTPUT SIGNAL LINE (IC808 OUTPUT)

SCHEMATIC DIAGRAMS (32/36)  
 8U-210095-1 ANALOG VIDEO UNIT (2/3)  
 VIDEO ENCODER for Y/C CVBS

FILE NAME : 00210095\_C1V/002.SHT

UD8004







# 5201 DISPLAY/KEY PWB

FL 101  
FL-TUBE (15-BT-114GNK)

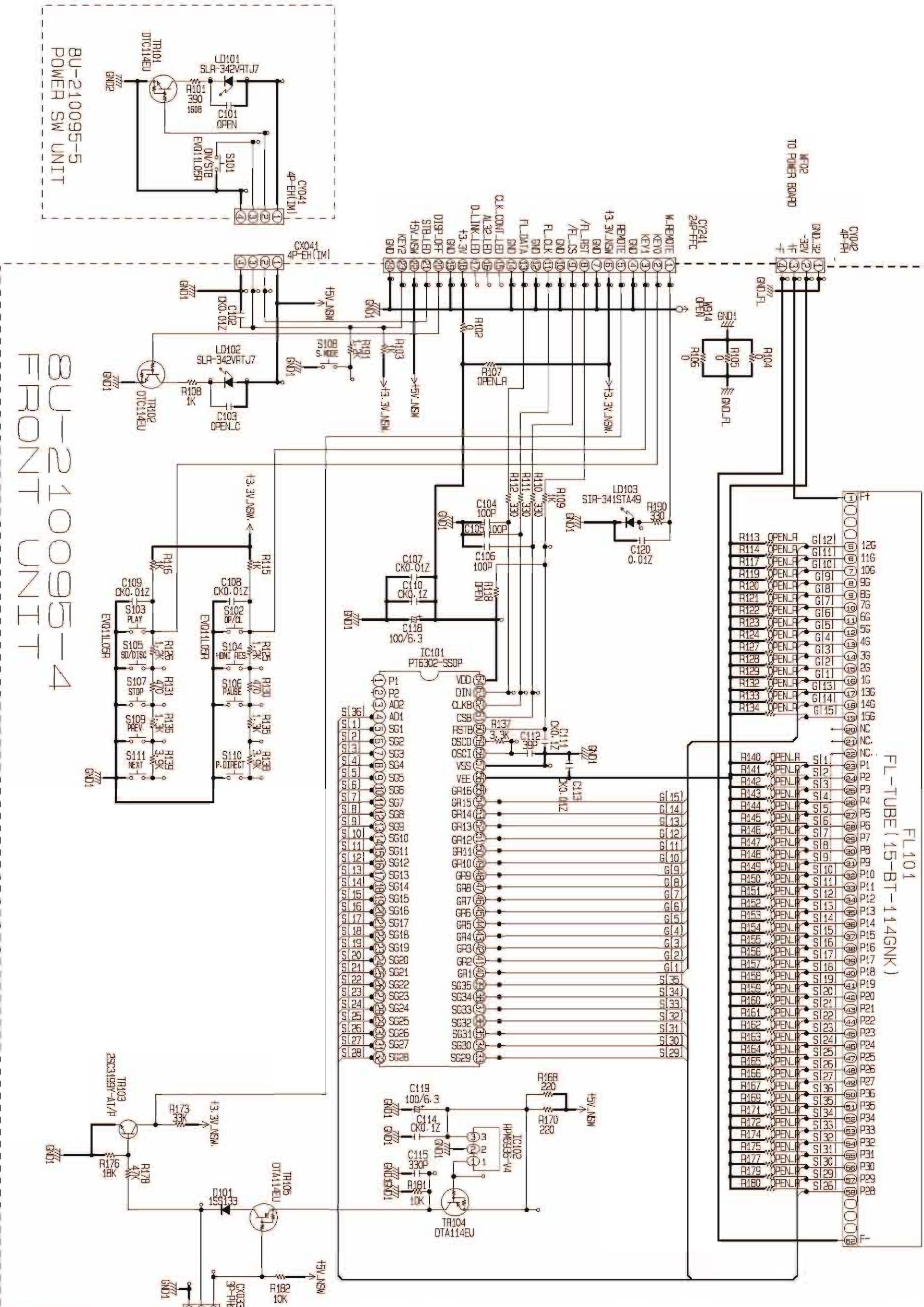

FILE NAME : 00210095\_C17V\_005\_SHT

BU-210095-5  
FRONT UNIT

BU-210095-5  
POWER SW UNIT

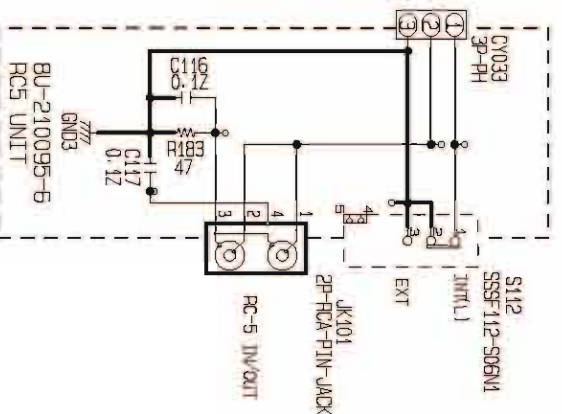

BU-210095-6  
RC5 UNIT

## SCHEMATIC DIAGRAMS (35/36)

- 8U-210095-4 FRONT UNIT
- 8U-210095-5 POWER SW UNIT
- 8U-210095-6 RC5 UNIT

UD8004

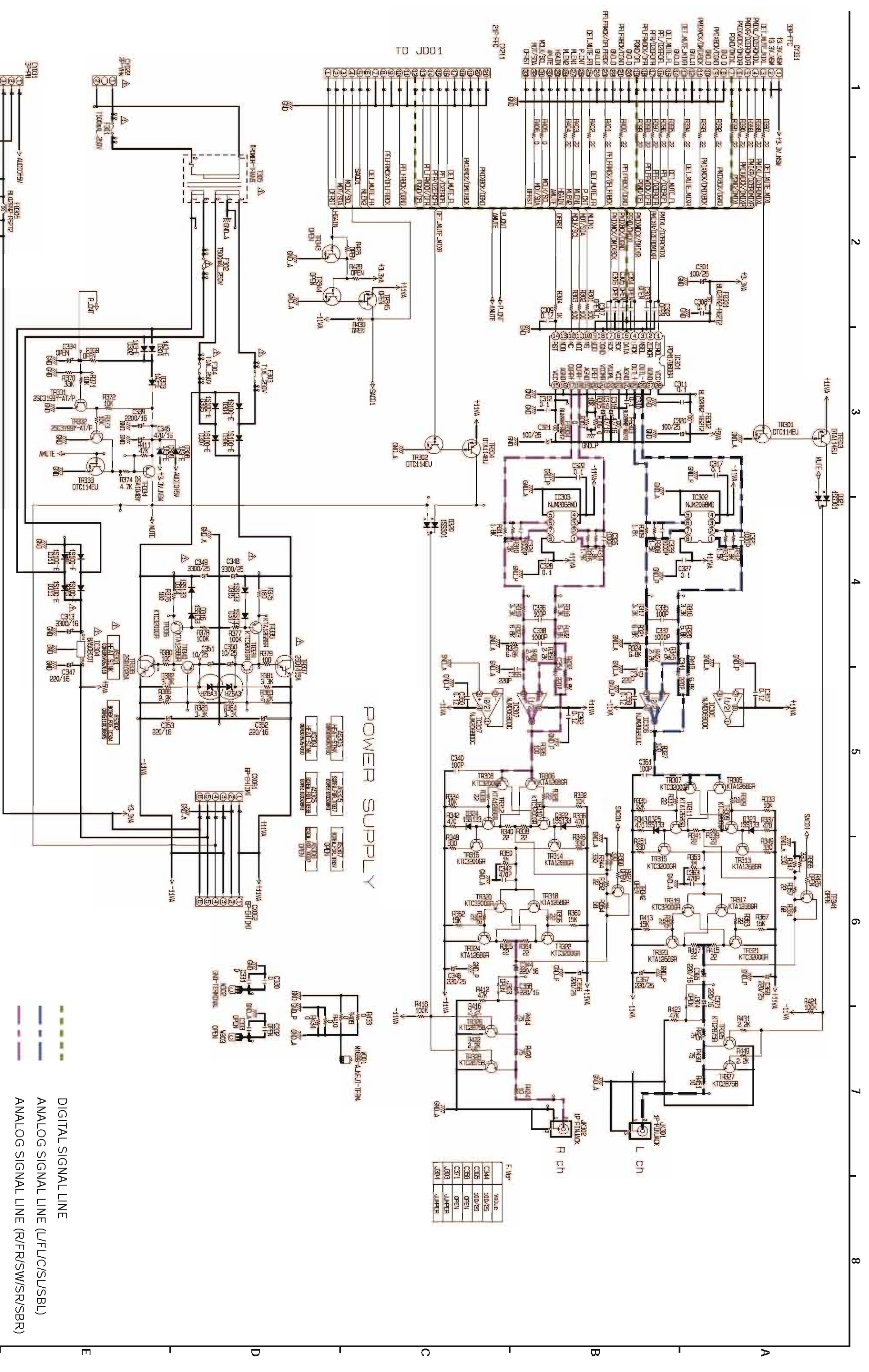

# BU-210095-7 AUDIO UNIT

DIGITAL SIGNAL LINE  
 ANALOG SIGNAL LINE (L/FL/C/S/USB/L)  
 ANALOG SIGNAL LINE (R/FR/SW/SR/SBR)

F:V#P	VALUE
C344	100/25
C365	100/25
C369	100/25
C371	OPEN
C373	OPEN
J304	JUMPER