

Service Manual

VC5200 /U1B

DVD Changer

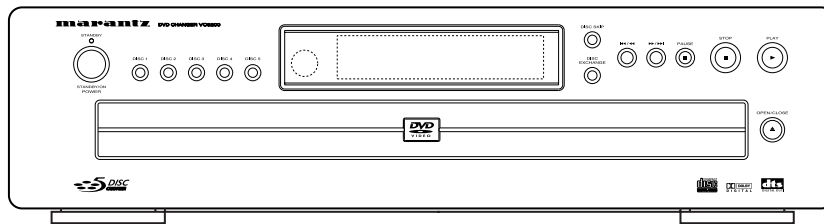

TABLE OF CONTENTS

SECTION	PAGE
1. TECHNICAL SPECIFICATIONS	1
2. PRODUCT SAFETY SERVICING GUIDELINES FOR VIDEO PRODUCTS	2
3. SERVICING PRECAUTIONS	3
4. REGIONAL CODES	4
5. INFORMATIONS	5
6. SERVICING HINT	6
7. LOCATION OF CUSTOMER CONTROLS	7
8. DISASSEMBLY	10
9. EXPLODED VIEWS/MECHANICAL PARTS LIST	12
10. ELECTRICAL TROUBLESHOOTING GUIDE	15
11. BLOCK DIAGRAMS	25
12. CIRCUIT DIAGRAMS	31
13. PRINTED CIRCUIT DIAGRAMS	53
14. ELECTRICAL PARTS LIST	57
15. DVD DECK MECHANISM SECTION	2-1

Please use this service manual with referring to the user guide (D.F.U) without fail.

marantz®



百紙配合率100%再生紙を使用しています
Printed on 100% Recycled Paper

Printed in Japan

VC5200

346W855010 ACT
First Issue:2002.01

VC5200

MARANTZ DESIGN AND SERVICE

Using superior design and selected high grade components, **MARANTZ** company has created the ultimate in stereo sound. Only original **MARANTZ** parts can insure that your **MARANTZ** product will continue to perform to the specifications for which it is famous.

Parts for your **MARANTZ** equipment are generally available to our National Marantz Subsidiary or Agent.

ORDERING PARTS :

Parts can be ordered either by mail or by Fax.. In both cases, the correct part number has to be specified.

The following information must be supplied to eliminate delays in processing your order :

1. Complete address
2. Complete part numbers and quantities required
3. Description of parts
4. Model number for which part is required
5. Way of shipment
6. Signature : any order form or Fax. must be signed, otherwise such part order will be considered as null and void.

USA

MARANTZ AMERICA, INC.
1100 MAPLEWOOD DRIVE
ITASCA, IL. 60143
USA
PHONE : 630 - 741 - 0300
FAX : 630 - 741 - 0301

EUROPE / TRADING

MARANTZ EUROPE B.V.
P.O.BOX 80002, BUILDING SFF2
5600 JB EINDHOVEN
THE NETHERLANDS
PHONE : +31 - 40 - 2732241
FAX : +31 - 40 - 2735578

BRAZIL

PHILIPS DA AMAZONIA IND. ELET. ITDA
CENTRO DE INFORMACOES AO
CEP 04698-970
SAO PAULO, SP, BRAZIL
PHONE : 0800 - 123123(Discagem Direta Gratuita)
FAX : +55 11 534. 8988

PROFESSIONAL AMERICAS

SUPERSCOPE TECHNOLOGIES, INC.
MARANTZ PROFESSIONAL PRODUCTS
2640 WHITE OAK CIRCLE, SUITE A
AURORA, ILLINOIS 60504 USA
PHONE : 630 - 820 - 4800
FAX : 630 - 820 - 8103

PROFESSIONAL AUSTRALIA

TECHNICAL AUDIO GROUP PTY, LTD
558 DARLING STREET,
BALMAIN, NSW 2041,
AUSTRALIA
PHONE : 61 - 2 - 9810 - 5300
FAX : 61 - 2 - 9810 - 5355

CANADA

LENBROOK INDUSTRIES LIMITED
633 GRANITE COURT,
PICKERING, ONTARIO L1W 3K1
CANADA
PHONE : 905 - 831 - 6333
FAX : 905 - 831 - 6936

AUSTRALIA

Qualifi Pty Ltd,
24 LIONEL ROAD,
MT. WAVERLEY VIC 3149
AUSTRALIA
PHONE : +61 - (0)3 - 9543 - 1522
FAX : +61 - (0)3 - 9543 - 3677

THAILAND

MRZ STANDARD CO.,LTD
746 - 754 MAHACHAI ROAD.,
WANGBURAPAPIROM, PHRANAKORN,
BANGKOK, 10200 THAILAND
PHONE : +66 - 2 - 222 9181
FAX : +66 - 2 - 224 6795

SINGAPORE

WO KEE HONG DISTRIBUTION PTE LTD
130 JOO SENG ROAD
#03-02 OLIVINE BUILDING
SINGAPORE 368357
PHONE : +65 858 5535 / +65 381 8621
FAX : +65 858 6078

NEW ZEALAND

WILDASH AUDIO SYSTEMS NZ
14 MALVERN ROAD MT ALBERT
AUCKLAND NEW ZEALAND
PHONE : +64 - 9 - 8451958
FAX : +64 - 9 - 8463554

TAIWAN

PAI- YUING CO., LTD.
6 TH FL NO, 148 SUNG KIANG ROAD,
TAIPEI, 10429, TAIWAN R.O.C.
PHONE : +886 - 2 - 25221304
FAX : +886 - 2 - 25630415

MALAYSIA

WO KEE HONG ELECTRONICS SDN. BHD.
SUITE 8.1, LEVEL 8, MENARA GENESIS,
NO. 33, JALAN SULTAN ISMAIL,
50250 KUALA LUMPUR, MALAYSIA
PHONE : +60 3 - 2457677
FAX : +60 3 - 2458180

JAPAN *Technical*

MARANTZ JAPAN, INC.
35- 1, 7- CHOME, SAGAMIONO
SAGAMIHARA - SHI, KANAGAWA
JAPAN 228-8505
PHONE : +81 42 748 1013
FAX : +81 42 741 9190

日本マランツ株式会社

本社 〒228-8505
神奈川県相模原市相模大野7-35-1
営業本部 〒150-0022
東京都渋谷区恵比寿南1-11-9

KOREA

MK ENTERPRISES LTD.
ROOM 604/605, ELECTRO-OFFICETEL, 16-58,
3GA, HANGANG-RO, YONGSAN-KU, SEOUL
KOREA
PHONE : +822 - 3232 - 155
FAX : +822 - 3232 - 154

SHOCK, FIRE HAZARD SERVICE TEST :

CAUTION : After servicing this appliance and prior to returning to customer, measure the resistance between either primary AC cord connector pins (with unit NOT connected to AC mains and its Power switch ON), and the face or Front Panel of product and controls and chassis bottom.

Any resistance measurement less than 1 Megohms should cause unit to be repaired or corrected before AC power is applied, and verified before it is return to the user/customer.

Ref. UL Standard No. 1492.

In case of difficulties, do not hesitate to contact the Technical Department at above mentioned address.

REMARK

This service manual corresponds to service modification code number "MZ01" and later. When exchanging MAIN PCB on the product of the service modification code "MZ00", it is necessary to also exchange the following parts on the I/O PCB simultaneously.

(The service modification code is mentioned in the number label on the rear panel. Ex.MZ01xxxxxxxxxx)

Two kinds of MPEG ICs (IC501) exist in this model. Since the conventional IC (Pantera-2) became a production stop, this was generated. Since power supply voltage is changed, new IC (Pantera-2 Plus) has change in a power supply part. In the case of repair, please fix after checking the version of IC.

	Service modification code	
	MZ00	MZ01
Location	<Pantera-2>	<Pantera-2 Plus>
D116	1N17	Tin Wire
D117	1N17	Tin Wire
C127	2200uF/6.3V	220uF/6.3V

1. TECHNICAL SPECIFICATIONS

DVD VIDEO PLAYER

Power supply	AC120 V, 60 Hz
Power consumption	16 W
Mass	5.7 kg (12.6 lbs)
External dimensions	440 x 118 x 423 (W x H x D)
Signal system	NTSC
Laser	(DVD) Semiconductor laser, wavelength 650 nm (CD) 780 nm
Frequency range (audio)	DVD : fs = 96 kHz 4 Hz - 44 kHz fs = 48 kHz 4 Hz - 22 kHz CD: 4 Hz - 20 kHz
Signal-to-noise ratio (audio)	More than 105dB (EIAJ)
Audio dynamic range (audio)	More than 100dB (EIAJ)
Harmonic distortion (audio)	0.003%
Wow and flutter	Below measurable level (less than +0.001%(W.PEAK)) (EIAJ)
Operations	Temperature : 5°C(41°F) to 35°C(95°F), Operation status : Horizontal

OUTPUTS

Video outputs	1.0V(p-p), 75Ω, negative sync., RCA jack x 1
S-video outputs	(Y)1.0V(p-p), 75Ω, negative sync., Mini DIN 4-pin x 1 (C)0.286V(p-p), 75Ω
Component video output	(Y)1.0V(p-p), 75Ω,negative sync., RCA jack x 1 (Cb)/(Cr) 0.7V(p-p), 75Ω
Audio output (Optical)	Optical Connector x 1
(Coaxial)	0.5V(p-p), 75Ω, RCA jack x 1
Audio output (analog audio)	2.0Vrms (1kHz, 0dB), 330Ω, RCA jack (L, R) x 2

*Designs and specifications are subject to change without notice.

2. PRODUCT SAFETY SERVICING GUIDELINES FOR VIDEO PRODUCTS

CAUTION : DO NOT ATTEMPT TO MODIFY THIS PRODUCT IN ANY WAY, NEVER PERFORM CUSTOMIZED INSTALLATIONS WITHOUT MANUFACTURER'S APPROVAL. UNAUTHORIZED MODIFICATIONS WILL NOT ONLY VOID THE WARRANTY, BUT MAY LEAD TO YOUR BEING LIABLE FOR ANY RESULTING PROPERTY DAMAGE OR USER INJURY.

SERVICE WORK SHOULD BE PERFORMED ONLY AFTER YOU ARE THOROUGHLY FAMILIAR WITH ALL OF THE FOLLOWING SAFETY CHECKS AND SERVICING GUIDELINES. TO DO OTHERWISE, INCREASES THE RISK OF POTENTIAL HAZARDS AND INJURY TO THE USER.

WHILE SERVICING, USE AN ISOLATION TRANSFORMER FOR PROTECTION FROM A.C. LINE SHOCK.

SAFETY CHECKS

AFTER THE ORIGINAL SERVICE PROBLEM HAS BEEN CORRECTED. A CHECK SHOULD BE MADE OF THE FOLLOWING.

SUBJECT : FIRE & SHOCK HAZARD

1. BE SURE THAT ALL COMPONENTS ARE POSITIONED IN SUCH A WAY AS TO AVOID POSSIBILITY OF ADJACENT COMPONENT SHORTS. THIS IS ESPECIALLY IMPORTANT ON THOSE MODULES WHICH ARE TRANSPORTED TO AND FROM THE REPAIR SHOP.
2. NEVER RELEASE A REPAIR UNLESS ALL PROTECTIVE DEVICES SUCH AS INSULATORS, BARRIERS, COVERS, SHIELDS, STRAIN RELIEFS, POWER SUPPLY CORDS, AND OTHER HARDWARE HAVE BEEN REINSTALLED PER ORIGINAL DESIGN. BE SURE THAT THE SAFETY PURPOSE OF THE POLARIZED LINE PLUG HAS NOT BEEN DEFEATED.
3. SOLDERING MUST BE INSPECTED TO DISCOVER POSSIBLE COLD SOLDER JOINTS, SOLDER SPLASHES OR SHARP SOLDER POINTS. BE CERTAIN TO REMOVE ALL LOOSE FOREIGN PARTICLES.
4. CHECK FOR PHYSICAL EVIDENCE OF DAMAGE OR DETERIORATION TO PARTS AND COMPONENTS, FOR FRAYED LEADS, DAMAGED INSULATION (INCLUDING A.C. CORD), AND REPLACE IF NECESSARY. FOLLOW ORIGINAL LAYOUT, LEAD LENGTH AND DRESS.
5. NO LEAD OR COMPONENT SHOULD TOUCH A RECEIVING TUBE OR A RESISTOR RATED AT 1 WATT OR MORE. LEAD TENSION AROUND PROTRUDING METAL SURFACES MUST BE AVOIDED.
6. ALL CRITICAL COMPONENTS SUCH AS FUSES, FLAMEPROOF RESISTORS, CAPACITORS, ETC. MUST BE REPLACED WITH EXACT FACTORY TYPES. DO NOT USE REPLACEMENT COMPONENTS OTHER THAN THOSE SPECIFIED OR MAKE UNRECOMMENDED CIRCUIT MODIFICATIONS.
7. AFTER RE-ASSEMBLY OF THE SET ALWAYS PERFORM AN A.C. LEAKAGE TEST ON ALL EXPOSED METALLIC PARTS OF THE CABINET, (THE CHANNEL SELECTOR KNOB, ANTENNA TERMINALS, HANDLE AND SCREWS) TO BE SURE THE SET IS SAFE TO OPERATE WITHOUT DANGER OF ELECTRICAL SHOCK. DO NOT USE A LINE ISOLATION TRANSFORMER DURING THIS TEST USE AN A.C. VOLTMETER, HAVING 5000 OHMS PER VOLT OR MORE SENSITIVITY, IN THE FOLLOWING MANNER; CONNECT A 1500 OHM 10 WATT RESISTOR, PARALLELED BY A .15 MFD. 150.V A.C TYPE CAPACITOR BETWEEN A KNOWN GOOD EARTH GROUND (WATER PIPE, CONDUIT, ETC.) AND THE EXPOSED METALLIC PARTS, ONE AT A TIME. MEASURE THE A.C. VOLTAGE ACROSS THE COMBINATION OF 1500 OHM RESISTOR AND .15 MFD CAPACITOR. REVERSE THE A.C. PLUG AND REPEAT A.C. VOLTAGE MEASUREMENTS FOR EACH EXPOSED METALLIC PART. VOLTAGE MEASURED MUST NOT EXCEED 75 VOLTS R.M.S. THIS CORRESPONDS TO 0.5 MILLIAMPS A.C ANY VALUE EXCEEDING THIS LIMIT CONSTITUTES A POTENTIAL SHOCK HAZARD AND MUST BE CORRECTED IMMEDIATELY.

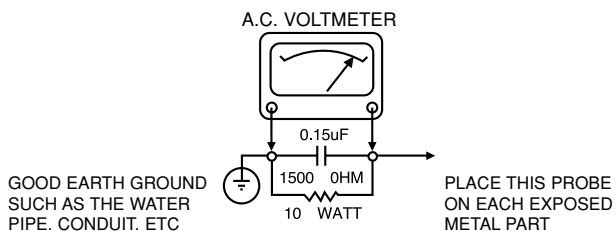

SUBJECT: GRAPHIC SYMBOLS



THE LIGHTNING FLASH WITH APROWHEAD SYMBOL, WITHIN AN EQUILATERAL TRIANGLE, IS INTENDED TO ALERT THE SERVICE PERSONNEL TO THE PRESENCE OF UNINSULATED "DANGEROUS VOLTAGE" THAT MAY BE OF SUFFICIENT MAGNITUDE TO CONSTITUTE A RISK OF ELECTRIC SHOCK.



THE EXCLAMATION POINT WITHIN AN EQUILATERAL TRIANGLE IS INTENDED TO ALERT THE SERVICE PERSONNEL TO THE PRESENCE OF IMPORTANT SAFETY INFORMATION IN SERVICE LITERATURE.

SUBJECT : X-RADIATION

1. BE SURE PROCEDURES AND INSTRUCTIONS TO ALL SERVICE PERSONNEL COVER THE SUBJECT OF X-RADIATION. THE ONLY POTENTIAL SOURCE OF X-RAYS IN CURRENT T.V. RECEIVERS IS THE PICTURE TUBE. HOWEVER, THIS TUBE DOES NOT EMIT X-RAYS WHEN THE HIGH VOLTAGE IS AT THE FACTORY SPECIFIED LEVEL. THE PROPER VALUE IS GIVEN IN THE APPLICABLE SCHEMATIC. OPERATION AT HIGHER VOLTAGES MAY CAUSE A FAILURE OF THE PICTURE TUBE OR HIGH VOLTAGE SUPPLY AND, UNDER CERTAIN CIRCUMSTANCES, MAY PRODUCE RADIATION IN EXCESS OF DESIRABLE LEVELS.
2. ONLY FACTORY SPECIFIED C.R.T. ANODE CONNECTORS MUST BE USED. DEGAUSSING SHIELDS ALSO SERVE AS AN X-RAY SHIELD IN COLOR SETS, ALWAYS RE-INSTALL THEM.
3. IT IS ESSENTIAL THAT SERVICE PERSONNEL HAVE AVAILABLE AN ACCURATE AND RELIABLE HIGH VOLTAGE METER. THE CALIBRATION OF THE METER SHOULD BE CHECKED PERIODICALLY AGAINST A REFERENCE STANDARD, SUCH AS THE ONE AVAILABLE AT YOUR DISTRIBUTOR.
4. WHEN THE HIGH VOLTAGE CIRCUITRY IS OPERATING PROPERLY THERE IS NO POSSIBILITY OF AN X-RADIATION PROBLEM. EVERY TIME A COLOR CHASSIS IS SERVICED, THE BRIGHTNESS SHOULD BE RUN UP AND DOWN WHILE MONITORING THE HIGH VOLTAGE WITH A METER TO BE CERTAIN THAT THE HIGH VOLTAGE DOES NOT EXCEED THE SPECIFIED VALUE AND THAT IT IS REGULATING CORRECTLY. WE SUGGEST THAT YOU AND YOUR SERVICE ORGANIZATION REVIEW TEST PROCEDURES SO THAT VOLTAGE REGULATION IS ALWAYS CHECKED AS A STANDARD SERVICING PROCEDURE AND THAT THE HIGH VOLTAGE READING BE RECORDED ON EACH CUSTOMER'S INVOICE.
5. WHEN TROUBLESHOOTING AND MAKING TEST MEASUREMENTS IN A PRODUCT WITH A PROBLEM OF EXCESSIVE HIGH VOLTAGE, AVOID BEING UNNECESSARILY CLOSE TO THE PICTURE TUBE AND THE HIGH VOLTAGE SUPPLY. DO NOT OPERATE THE PRODUCT LONGER THAN IT IS NECESSARY TO LOCATE THE CAUSE OF EXCESSIVE VOLTAGE.
6. REFER TO HV. B+ AND SHUTDOWN ADJUSTMENT PROCEDURES DESCRIBED IN THE APPROPRIATE SCHEMATIC AND DIAGRAMS (WHERE USED).

SUBJECT: IMPLOSION

1. ALL DIRECT VIEWED PICTURE TUBES ARE EQUIPPED WITH AN INTEGRAL IMPLOSION PROTECTION SYSTEM, BUT CARE SHOULD BE TAKEN TO AVOID DAMAGE DURING INSTALLATION, AVOID SCRATCHING THE TUBE. IF SCRATCHED REPLACE IT.
2. USE ONLY RECOMMENDED FACTORY REPLACEMENT TUBES.

SUBJECT : TIPS ON PROPER INSTALLATION

1. NEVER INSTALL ANY PRODUCT IN A CLOSED-IN RECESS, CUBBY-HOLE OR CLOSELY FITTING SHELF SPACE, OVER OR CLOSE TO HEAT DUCT, OR IN THE PATH OF HEATED AIR FLOW.
2. AVOID CONDITIONS OF HIGH HUMIDITY SUCH AS: OUTDOOR PATIO INSTALLATIONS WHERE DEW IS A FACTOR, NEAR STEAM RADIATORS WHERE STEAM LEAKAGE IS A FACTOR, ETC.
3. AVOID PLACEMENT WHERE DRAPERIES MAY OBSTRUCT REAR VENTING. THE CUSTOMER SHOULD ALSO AVOID THE USE OF DECORATIVE SCARVES OR OTHER COVERINGS WHICH MIGHT OBSTRUCT VENTILATION.
4. WALL AND SHELF MOUNTED INSTALLATIONS USING A COMMERCIAL MOUNTING KIT, MUST FOLLOW THE FACTORY APPROVED MOUNTING INSTRUCTIONS. A PRODUCT MOUNTED TO A SHELF OR PLATFORM MUST RETAIN ITS ORIGINAL FEET (OR THE EQUIVALENT THICKNESS IN SPACERS) TO PROVIDE ADEQUATE AIR FLOW ACROSS THE BOTTOM. BOLTS OR SCREWS USED FOR FASTENERS MUST NOT TOUCH ANY PARTS OR WIRING. PERFORM LEAKAGE TEST ON CUSTOMIZED INSTALLATIONS.
5. CAUTION CUSTOMERS AGAINST THE MOUNTING OF A PRODUCT ON SLOPING SHELF OR A TILTED POSITION, UNLESS THE PRODUCT IS PROPERLY SECURED.
6. A PRODUCT ON A ROLL-ABOUT CART SHOULD BE STABLE ON ITS MOUNTING TO THE CART. CAUTION THE CUSTOMER ON THE HAZARDS OF TRYING TO ROLL A CART WITH SMALL CASTERS ACROSS THRESHOLDS OR DEEP PILE CARPETS.
7. CAUTION CUSTOMERS AGAINST THE USE OF A CART OR STAND WHICH HAS NOT BEEN LISTED BY UNDERWRITERS LABORATORIES, INC. FOR USE WITH THEIR SPECIFIC MODEL OF TELEVISION RECEIVER OR GENERICALLY APPROVED FOR USE WITH T.V.'S OF THE SAME OR LARGER SCREEN SIZE.
8. CAUTION CUSTOMERS AGAINST THE USE OF EXTENSION CORDS. EXPLAIN THAT A FOREST OF EXTENSIONS SPROUTING FROM A SINGLE OUTLET CAN LEAD TO DISASTROUS CONSEQUENCES TO HOME AND FAMILY.

3. SERVICING PRECAUTIONS

CAUTION : Before servicing the DVD covered by this service data and its supplements and ADDENDUMS, read and follow the *SAFETY PRECAUTIONS*. **NOTE :** if unforeseen circumstances create conflict between the following servicing precautions and any of the safety precautions in this publication, always follow the safety precautions.

Remember Safety First:

General Servicing Precautions

1. Always unplug the DVD AC power cord from the AC power source before:
 - (1) Removing or reinstalling any component, circuit board, module, or any other assembly.
 - (2) Disconnection or reconnecting any internal electrical plug or other electrical connection.
 - (3) Connecting a test substitute in parallel with an electrolytic capacitor.
Caution : A wrong part substitution or incorrect polarity installation of electrolytic capacitors may result in an explosion hazard.
2. Do not spray chemicals on or near this DVD or any of its assemblies.
3. Unless specified otherwise in this service data, clean electrical contacts by applying an appropriate contact cleaning solution to the contacts with a pipe cleaner, cotton-tipped swab, or comparable soft applicator. Unless specified otherwise in this service data, lubrication of contacts is not required.
4. Do not defeat any plug/socket B+ voltage interlocks with which instruments covered by this service manual might be equipped.
5. Do not apply AC power to this DVD and/or any of its electrical assemblies unless all solid-state device heat sinks are correctly installed.
6. Always connect test instrument ground lead to the appropriate ground before connection the test instrument positive lead. Always remove the test instrument ground lead last.

Insulation Checking Procedure

Disconnect the attachment plug from the AC outlet and turn the power on. Connect an insulation resistance meter(500V) to the blades of the attachment plug. The insulation resistance between each blade of the attachment plug and accessible conductive parts (Note 1) should be more than 1M-ohm.

Note 1 : Accessible Conductive Parts including Metal panels, Input terminals, Earphone jacks, etc.

Electrostatically Sensitive (ES) Devices

Some semiconductor (solid state) devices can be damaged easily by static electricity. Such components commonly are called Electrostatically Sensitive (ES) Devices. Examples of typical ES devices are integrated circuits and some field effect transistors and semiconductor chip components.

The following techniques should be used to help reduce the incidence of component damage caused by static electricity.

1. Immediately before handling any semiconductor component or semiconductor-equipped assembly, drain off any electrostatic charge on your body by touching a known earth ground. Alternatively, obtain and wear a commercially available discharging wrist strap device, which should be removed for potential shock reasons prior to applying power to the unit under test.
2. After removing an electrical assembly equipped with ES devices, place the assembly on a conductive surface such as aluminum foil, to prevent electrostatic charge buildup or exposure of the assembly.
3. Use only a GROUNDED-tip soldering iron to solder or unsolder ES devices.
4. Use only an anti-static solder removal device. Some solder removal devices not classified a "anti-static" can generate electrical charges sufficient to damage ES devices.
5. Do not use freon-propelled chemicals. These can generate electrical charge sufficient to damage ES devices.
6. Do not remove a replacement ES device from its protective package until immediately before you are ready to install it. (Most replacement ES devices are packaged with leads electrically shorted together by conductive foam, aluminum foil, or comparable conductive material).
7. Immediately before removing the protective material from the leads of a replacement ES device, touch the protective material to the chassis or circuit assembly into which the device will be installed.

Caution : Be sure no power is applied to the chassis or circuit, and observe all other safety precautions.

8. Minimize bodily motions when handling unpackaged replacement ES devices. (Normally harmless motion such as the brushing together of your clothes fabric or the lifting of your foot from a carpeted floor can generate static electricity sufficient to damage an ES device.)

4. REGIONAL CODES

What are "regional codes"?

Motion picture studios want to control the home release of movies in different countries because theater releases aren't simultaneous (a movie may come out on DVD in the US when it's just hitting screens in Europe). Therefore they have required that the DVD standard include codes which can be used to lock out the playback of certain discs in certain geographical regions. Players sold in each region will have that region's code built into the player. The player will refuse to play these "region coded" discs which are not allowed in the region. However, regional codes are entirely optional. Discs without codes will play on any player in any country. Some studios have already announced that only their new releases will have regional codes. There are six regions:

1. United States and Canada
2. Europe and Japan
3. Far East (except Japan & China)
4. South America and Oceania
5. Africa and the Middle East
6. China (except Hong Kong)

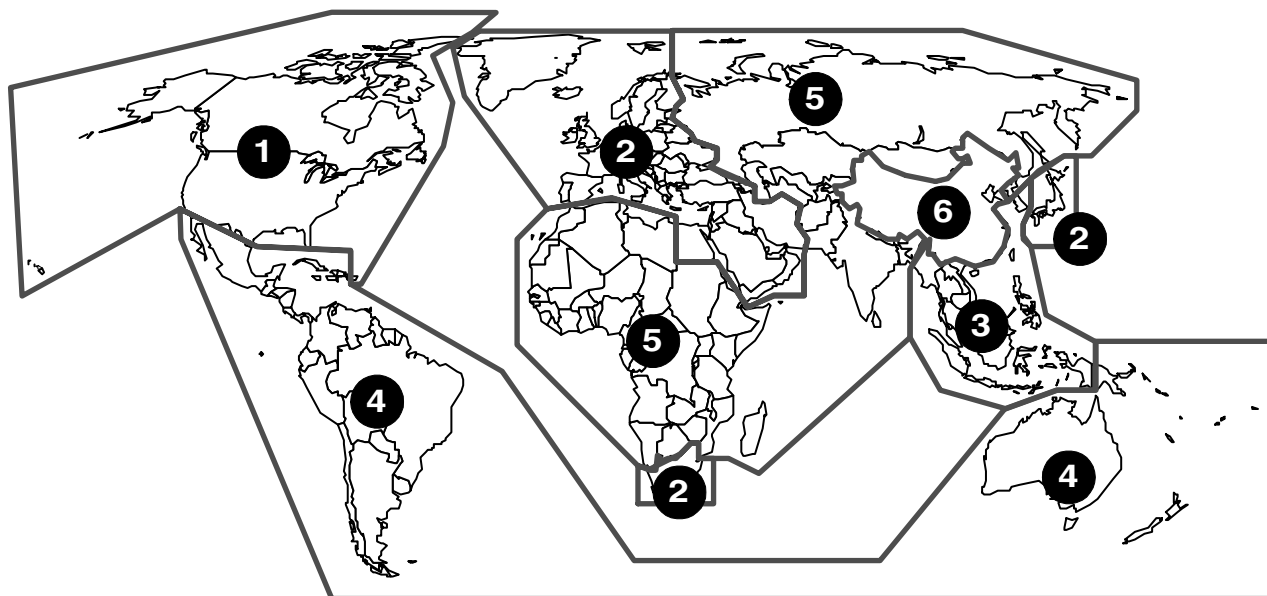

Map of DVD Regions



5. INFORMATIONS

REGION CODE

VERSION	REGION CODE	COUNTRY
/UXX	1	USA/CANADA

THE DISCS THAT THE VC5200 CAN HANDLE

The following discs can be played back with a VC5200.

disc	mark	playback capability	size	side
DVD		Audio/Video	12 cm 8 cm	single/double
VCD		Video	12 cm 8 cm	single
CD		Audio	12 cm 8 cm	single

Note: The regional code of the discs must meet to the regional code of the VC5200.

DVD INFORMATION

Below is a glossary of the new terms related to DVD.

Title:

A disc may have more than one story/movie on it, so each story/movie is called a "title".

For example, if there are 2 movies on the disc, they are separated into Title 1 and Title 2.

Chapter:

A title may also be separated into chapters.

For example, a movie (title) may be separated into 3 scenes (chapters).

Title 1			Title 2		
Chapter 1	Chapter 2	Chapter 3	Chapter 1	Chapter 2	Chapter 3

Subtitles:

DVDs are recorded with up to 32 different subtitle languages.

If a disc has more than one subtitle language, you can select the subtitle language that you want to read.

Soundtrack language:

DVDs are recorded with up to 8 different soundtrack languages.

If a disc has more than one language, you can select the soundtrack language that you want to listen to.

Multi-angles:

On some DVDs, scenes have been filmed from different angles (up to a maximum of 9). On these discs, you can select the angle that you want to watch. Please refer to the DVD's manual to see which scenes have multi-angles.

Parental guide:

Some discs have restriction levels that allow you to cut scenes or prevent playback of discs that have contents that you do not want children to watch.

6. SERVICING HINT

SERVICE HINTS

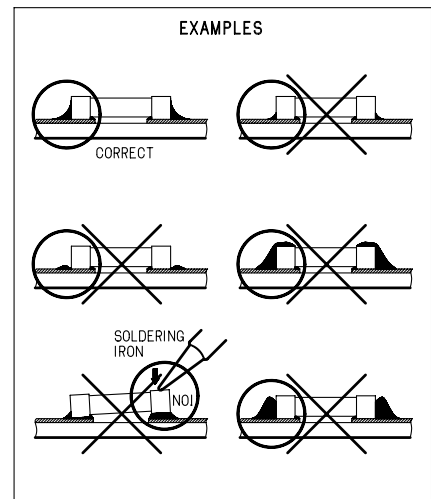
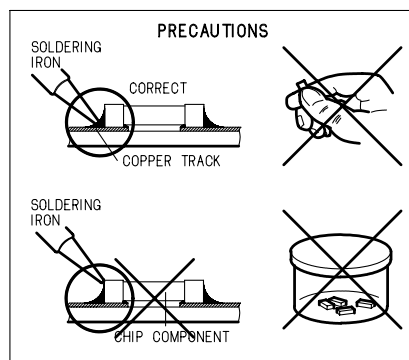
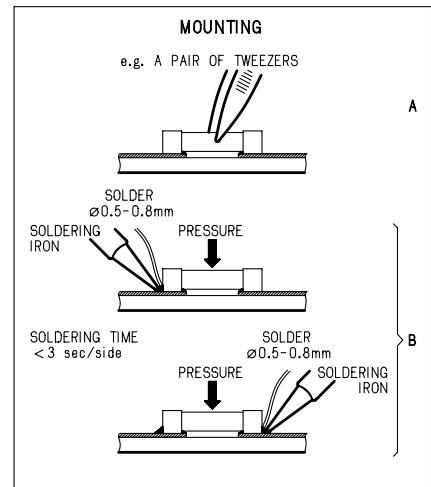
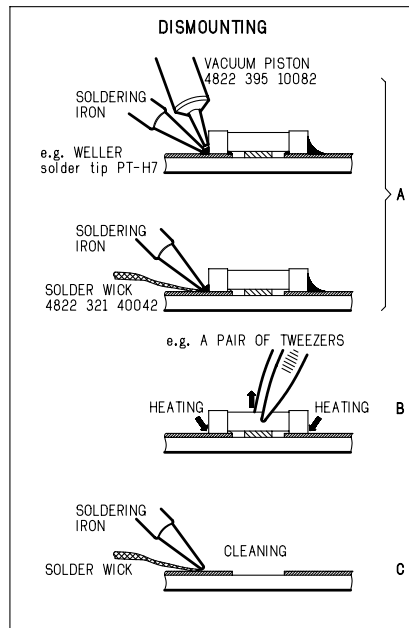
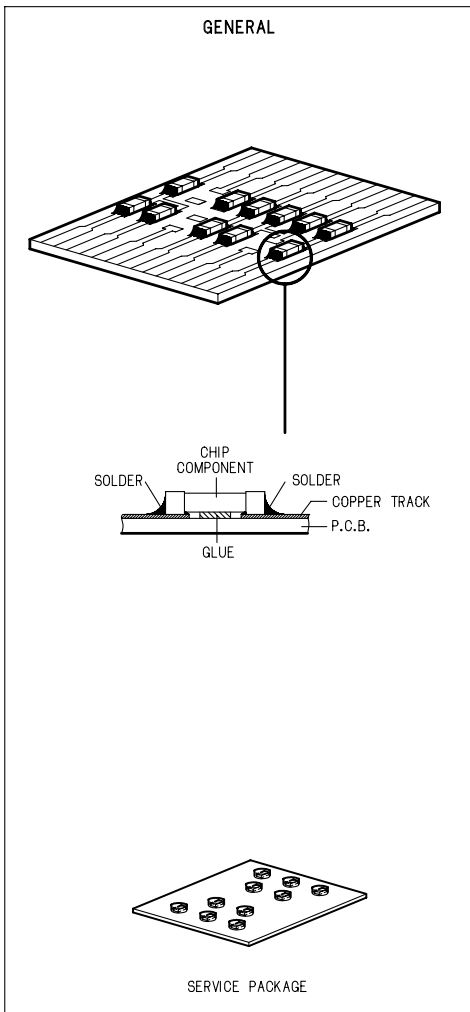

SERVICE TOOLS

Audio signals disc	4822 397 30184
Disc without errors (SBC444)+	
Disc with DO errors, black spots and fingerprints (SBC444A)	4822 397 30245
Disc (65 min 1kHz) without no pause	4822 397 30155
Max. diameter disc (58.0 mm)	4822 397 60141
Torx screwdrivers	
Set (straight)	4822 395 50145
Set (square)	4822 395 50132
13th order filter	4822 395 30204
DVD test disc	4822 397 10131

7. LOCATION OF CUSTOMER CONTROLS

FRONT

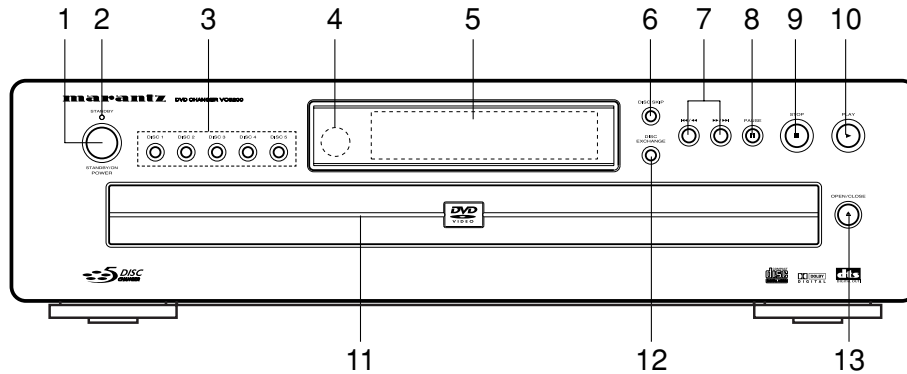

- | | |
|-----------------------------|--------------------------|
| 1. POWER BUTTON | 7. SKIP/SCAN BUTTONS |
| 2. POWER INDICATOR | 8. PAUSE BUTTON |
| 3. DISC SELECT(1~5) BUTTONS | 9. STOP BUTTON |
| 4. REMOTE SENSOR | 10. PLAY BUTTON |
| 5. DISPLAY WINDOW | 11. DISC TRAY |
| 6. DISC SKIP BUTTON | 12. DISC EXCHANGE BUTTON |
| | 13. OPEN/CLOSE BUTTON |

INDICATOR PANEL

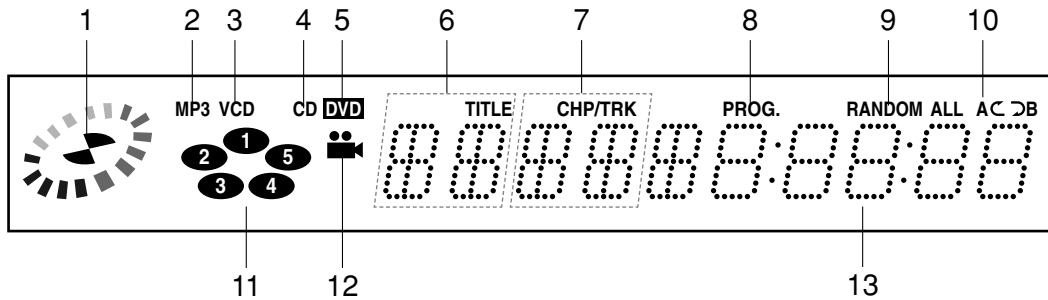

- | | |
|-----------------------------------|--|
| 1. OPERATING STATUS INDICATOR | 8. PROGRAM INDICATOR |
| 2. MP3 INDICATOR | 9. RANDOM INDICATOR |
| 3. VIDEO CD INDICATOR | 10. REPEAT PLAYBACK MODE INDICATORS |
| 4. CD INDICATOR | 11. DISC 1-5 INDICATORS |
| 5. DVD INDICATOR | 12. ANGLE ICON INDICATOR |
| 6. TITLE NUMBER INDICATOR | 13. TOTAL PLAYING TIME/
ELAPSED TIME INDICATORS |
| 7. CHAPTER/TRACK NUMBER INDICATOR | |

REAR

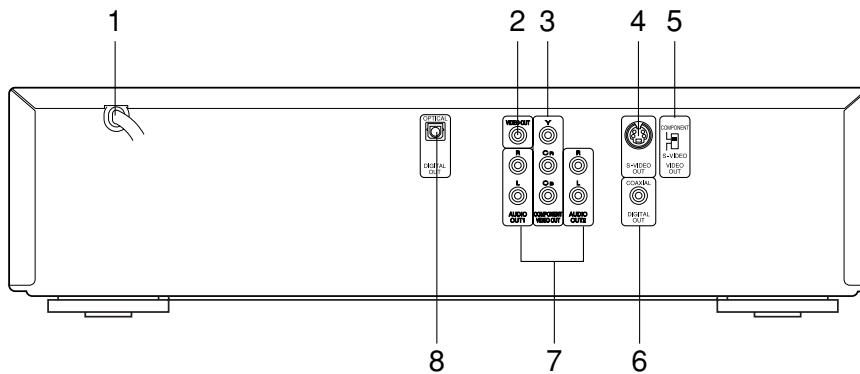

1. POWER CORD
2. VIDEO OUT JACK
3. COMPONENT VIDEO OUT/PROGRESSIVE SCAN JACKS
4. S-VIDEO OUT JACK
5. VIDEO OUTPUT SELECT SWITCH
6. COAXIAL DIGITAL AUDIO OUT JACK
7. AUDIO OUT (L/R) 1, 2 JACKS

8. OPTICAL DIGITAL AUDIO OUT JACK
 REMOVE THE DUST PROTECTION CAP FROM THE CONNECTOR AND CONNECT THE OPTICAL DIGITAL CABLE (NOT SUPPLIED) FIRMLY SO THAT THE CONFIGURATIONS OF BOTH THE CABLE AND THE CONNECTOR MATCH. KEEP THE DUST PROTECTION CAP AND ALWAYS REATTACH THE CAP WHEN NOT USING THE CONNECTOR TO PROTECT AGAINST DUST INTRUSION.

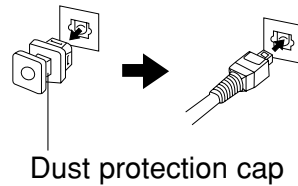

- This DVD player support two remote control codes: C1 and C2.
- When the unit is shipped from the factory, the remote code is set to C1.
- To change the remote control codes press and hold and hold CLEAR button for at least five seconds.
- Changed remote control codes is displayed in the display window.
- Set the remote control codes of the remote control to the same setting.

Notes

- This setting can not be used if a disc is playing.
- If a DVD has been loaded, be sure to press STOP twice before proceeding.

REMOTE CONTROL

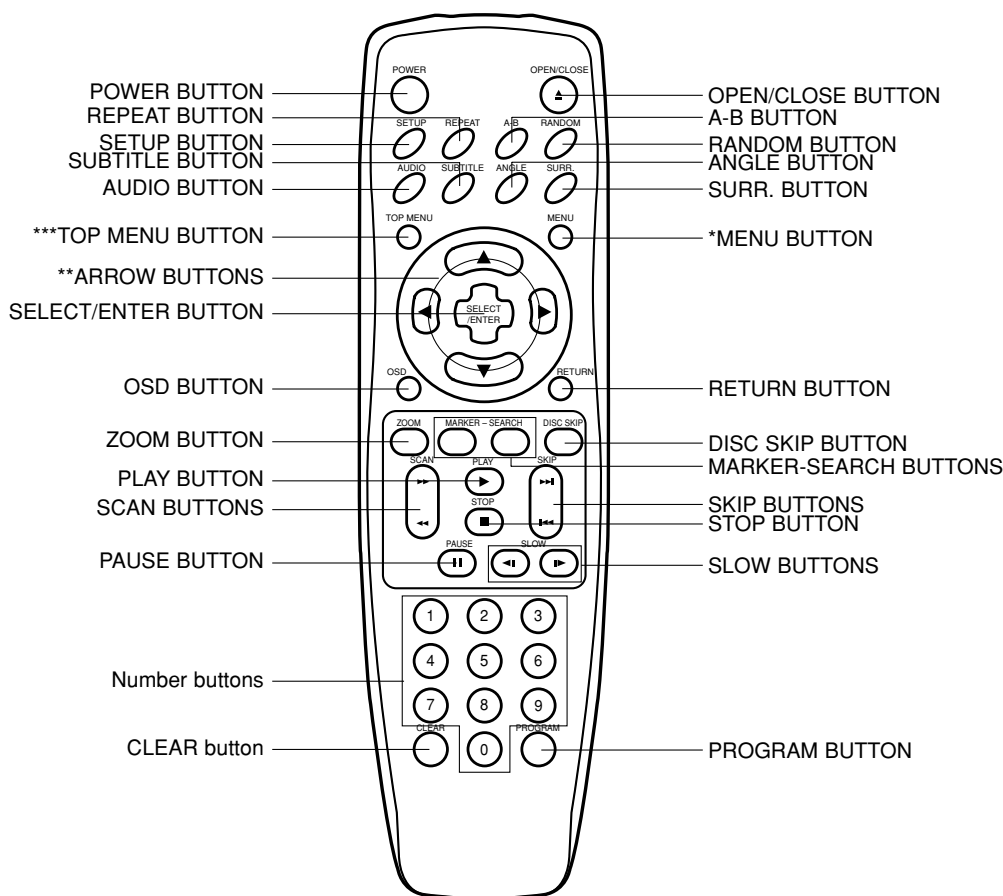

*MENU BUTTON

USE THE MENU BUTTON TO DISPLAY THE MENU SCREEN INCLUDED ON SELECTED DVD VIDEO DISCS. TO OPERATE A MENU SCREEN, FOLLOW THE INSTRUCTIONS IN "USING A DVD MENU" .

**DIRECTIONAL ARROW BUTTONS

(UP, DOWN, LEFT, RIGHT) FOR USE IN HIGHLIGHTING A SELECTION ON A GUI MENU SCREEN, TITLE AND MENU SCREEN.

***TOP MENU BUTTON

USE THE TOP MENU BUTTON TO DISPLAY THE TITLE MENU INCLUDED ON SELECTED DVD VIDEO DISCS. TO OPERATE A MENU SCREEN, FOLLOW THE INSTRUCTIONS IN "USING A TITLE MENU" .

- This remote control supports two remote control codes: C1 and C2.
- When the unit is shipped from the factory the remote control is set to C1.
- To set the remote control to C2, hold down both the STOP button and "2" number button on the remote control for at least five seconds. (If the batteries in the remote control are replaced while the remote control is set to C2, the setting will revert C1.)
- To set the remote control back to C1, hold down both the STOP button and "1" number button on the remote control for at least five seconds.
- Also set the remote control codes of the player to the same setting as the remote control. (This setting is set to C1, when the unit is shipped from the factory)

8. DISASSEMBLY

CAUTION BEFORE STARTING SERVICING

Electronic parts are susceptible to static electricity and may easily be damaged, so do not forget to take a proper grounding treatment as required.

Many screws are used inside the unit. To prevent missing, dropping, etc. of the screws, always use a magnetized screw driver in servicing. Several kinds of screws are used and some of them need special cautions. That is, take care of the tapping screws securing molded parts and fine pitch screws used to secure metal parts. If they are used improperly, the screw holes will be easily damaged and the parts can not be fixed.

CABINET DISASSEMBLY

1. Top Case

1. Release 7 screws (A). (See Fig. 2-1)
2. Lift the top case with holding the back of it, and remove it in the direction of the arrow.

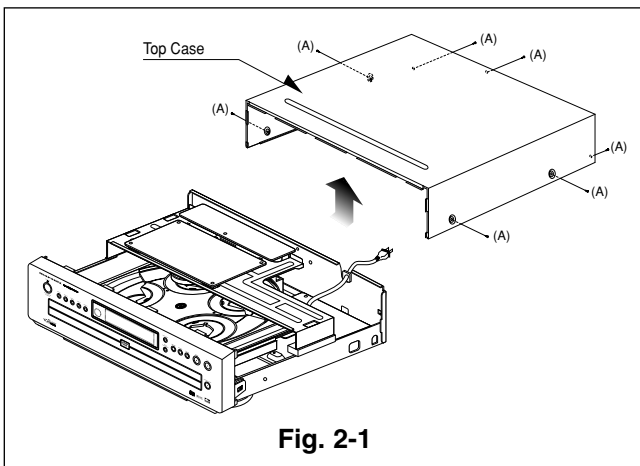

3. Front Panel

1. Eject the disc tray. (See Fig. 2-2)
2. Remove the tray door. (See Fig. 2-2)
3. Pull the front panel toward you while pressing 5 stoppers to disengage, and remove the front panel. (See Fig. 2-3)

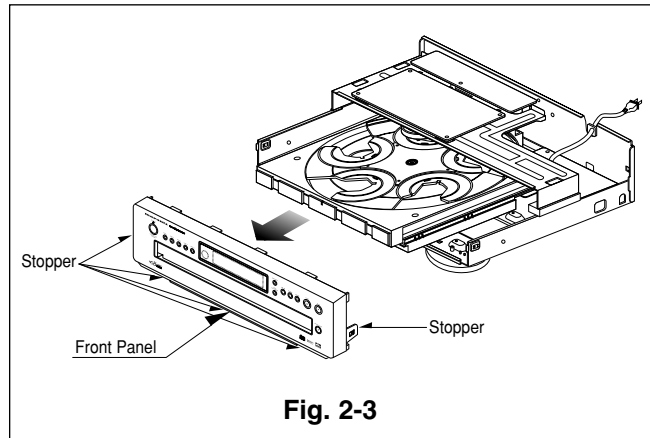

2. Tray Door

1. Eject the disc tray.
2. Lift up the tray door in the direction of the arrow.

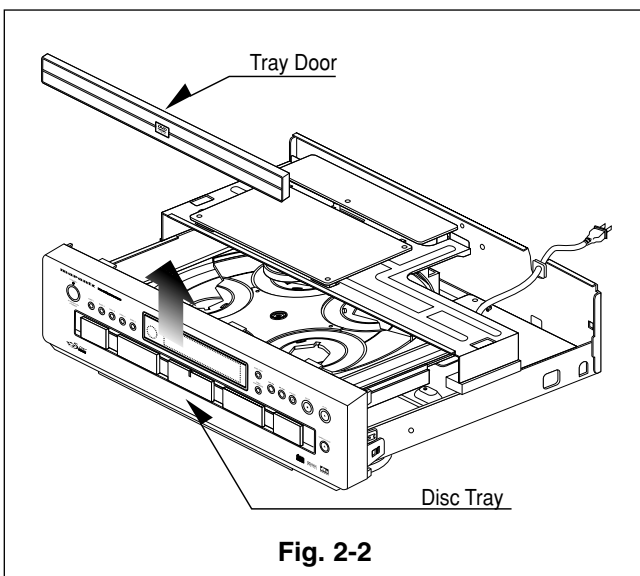

REMARK

Press OPEN/CLOSE button to open the tray.
If the tray does not work, please refer page 14.
(3. Taking out the disc)

CIRCUIT BOARD DISASSEMBLY

Note: Before removing the main circuit board, be sure to shortcircuit the laserdiode output land. After replacing the main circuit board, open the land after inserting the flexible connector. (Refer to Mechanism Disassembly)

1. Disassemble Main circuit board, Jack circuit board, Power circuit board and MD Ass'y DPM1.

1. Remove the top case.(See Fig. 2-1)
2. Remove 10 screws (B).
3. Disassemble Main circuit board and Jack circuit board from Bracket Main.
4. Unscrew 3 screws(C) at Bracket Main.
5. Disassemble Bracket Main from Main chassis.
6. Unscrew 4 screws(D) at MD Ass'y DPM1.
7. Turn the portion the direction of arrow to move the Base Assembly Tray in front of you.
8. Release the other 3 screws(E).
9. Disassemble MD Ass'y DPM1 from Main chassis.
10. Unscrew 4 screws(F) at Power circuit.
11. Disassemble power circuit board from Main chassis.

2. Digitron and Key Circuit Board

1. Remove the front panel.(See Fig. 2-3)
2. Release 5 screws (G), and remove the digitron circuit board.

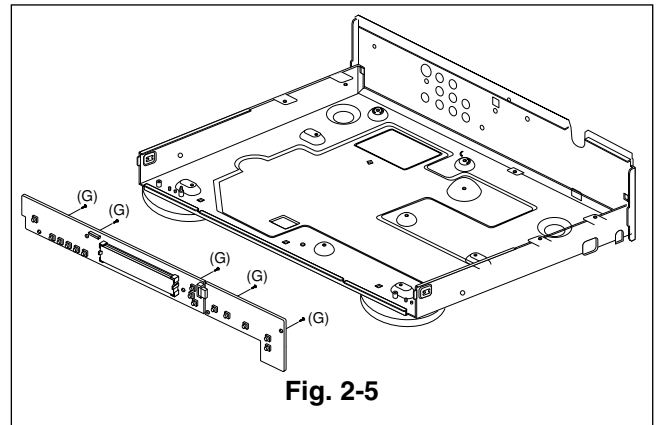

Fig. 2-5

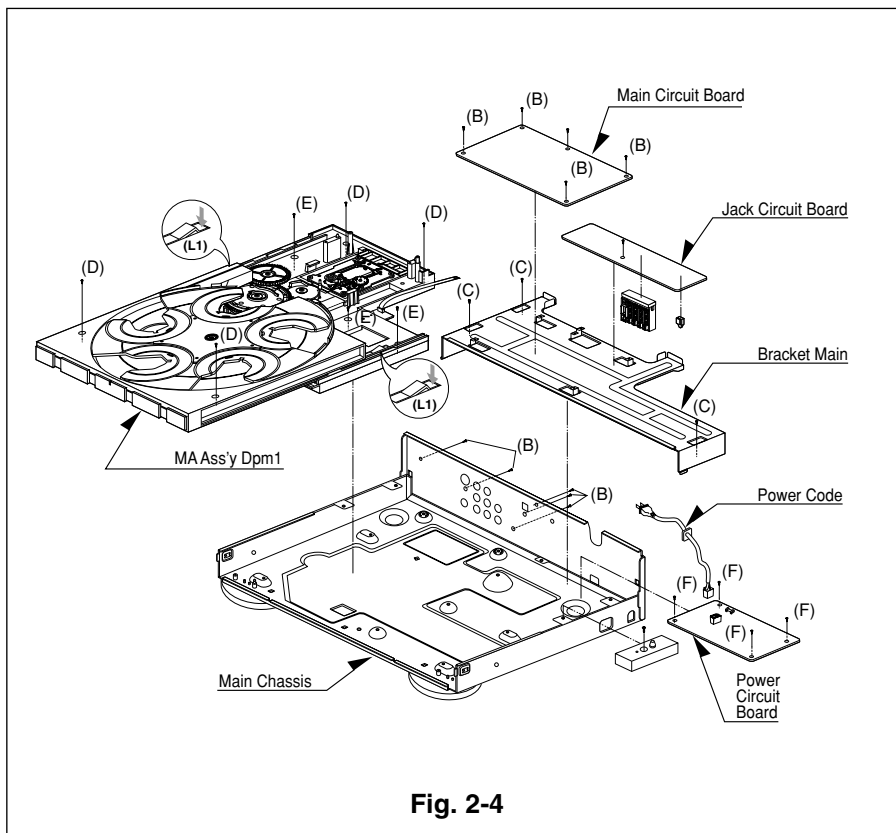
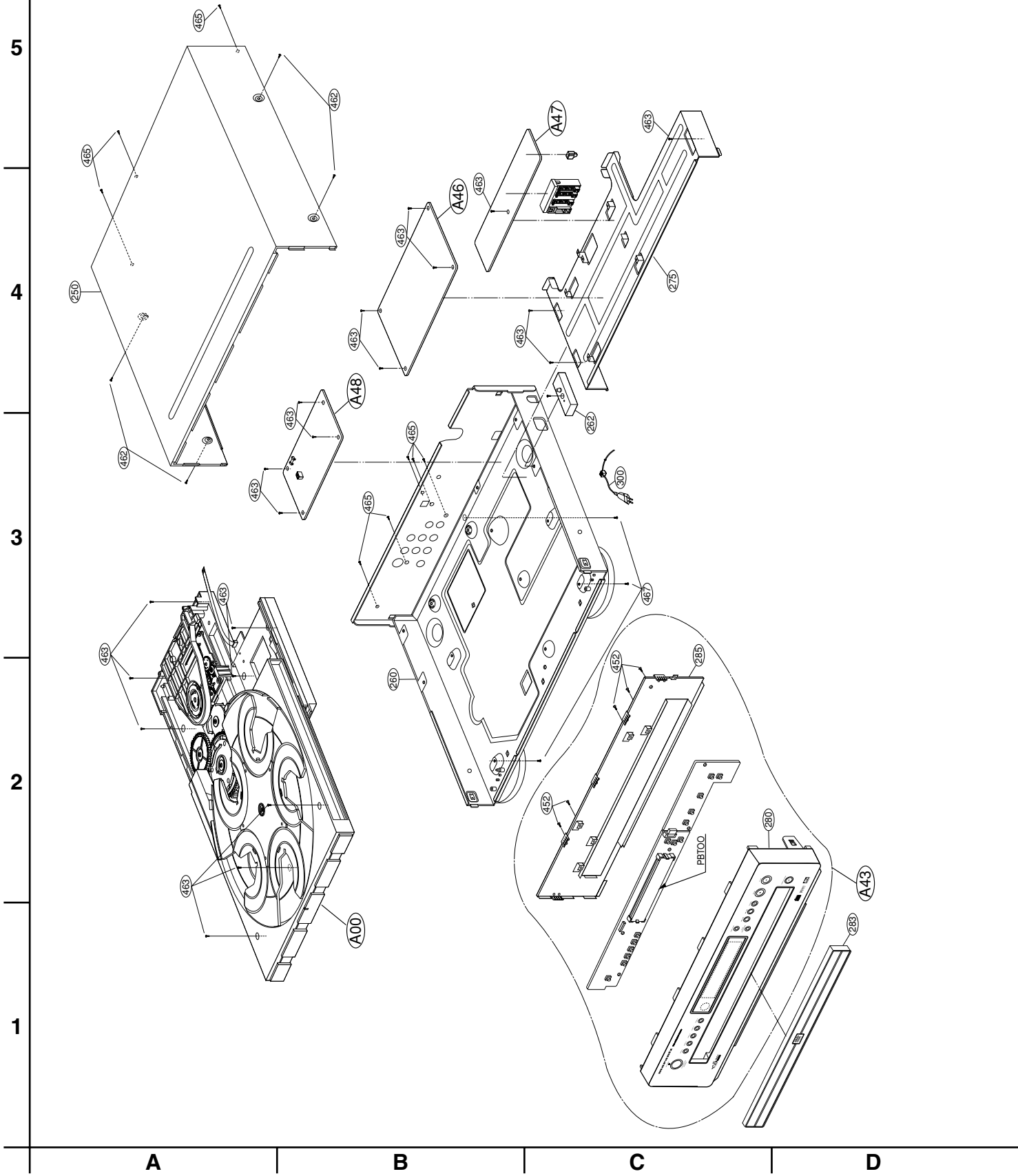

Fig. 2-4

9. EXPLODED VIEWS

1. Cabinet and Main Frame Section



POS. NO.	VERS. COLOR	DESCRIPTION	PART NO. (MJI)
A00		6721R-0314C DECK ASSY DPM1	nsp
A43		3501R-4508A BOARD ASSY FRONT	nsp
A46		6871R-4407G PCB ASSY MAIN RCA BAS	*ZZ001890R
A47		6871R-4408B PCB ASSY I/O	nsp
A48		3501R-3073G BOARD ASSY 5 CHANGER NARROW PLUS	nsp
250		3110R-0194G TOP COVER	nsp
260		3141R-0037N CHASSIS ASSY MAIN	nsp
262		RETAINER	nsp
275		4811R-0027D BRACKET ASSY MAIN	nsp
280		3721R-F221A PANEL ASSY FRONT	346W248500
283		3581R-T037A DOOR ASSY TRAY	346W063510
285		3301R-M013A PLATE ASSY SHIELD	nsp
300		6410RAHS02A MAINS CORD	*YC000450R
452		353-051A SCREW SPECIAL	nsp
462		353-085E SCREW DRAWING	nsp
463		353-051G SCREW DRAWING	nsp
465		353-046K SCREW SPECIAL (3X10 BK)	nsp
467		353-046N SCREW SPECIAL (3X8 BK)	nsp

NOTE : "nsp" PART IS LISTED FOR REFERENCE ONLY, MARANTZ WILL NOT SUPPLY THESE PARTS.

2.Packing Accessory Section

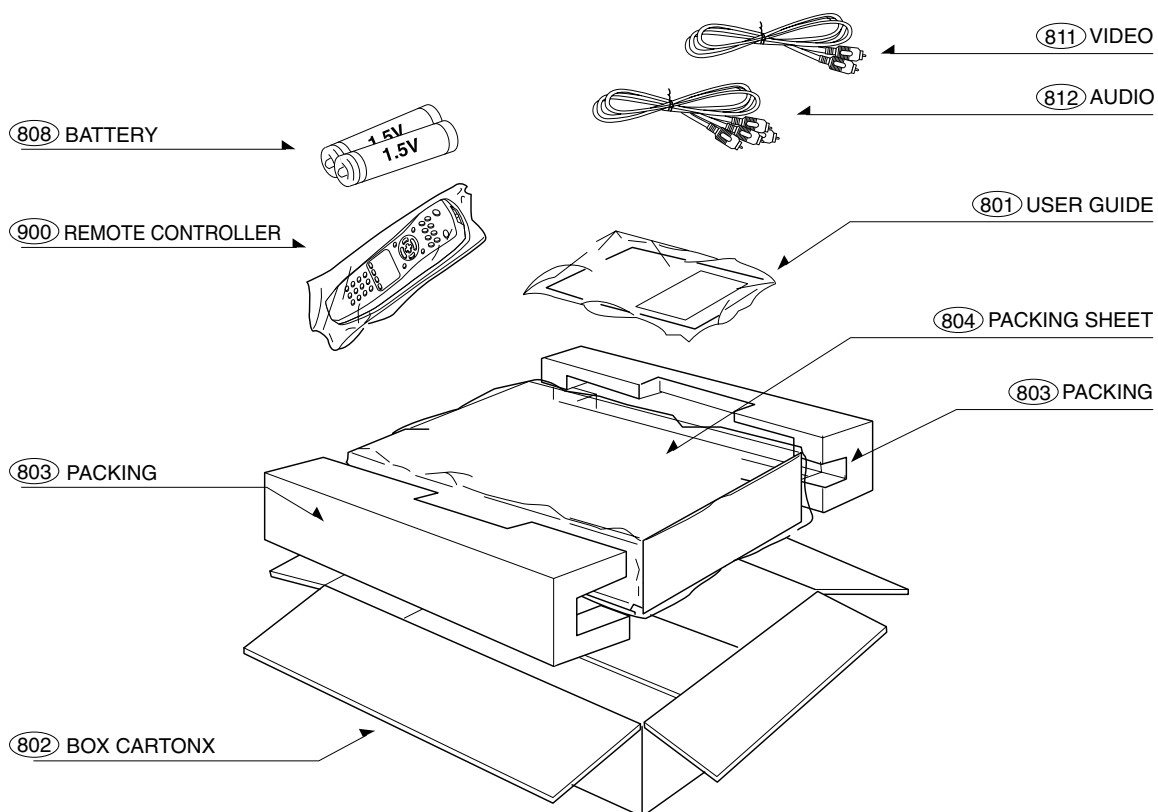

POS. NO.	VERS. COLOR	DESCRIPTION	PART NO. (MJI)
801		3835RS0021C USER GUIDE	346W851250
802		3890R-H500F BOX	nsp
803		3920R-E018A PACKING	nsp
804		3858R-S001B PACKING SHEET	nsp
808		534-008C BATTERY AAAM(R03) 1PAIR	nsp
811		564-017B VIDEO CORD 1WAY (YL)	nsp
812		564-018B AUDIO CORD 2WAY (RD/WH)	nsp
900		6711R2N060B REMOTE CONTROLLER RC5200VC	ZK346W0010

NOTE : "nsp" PART IS LISTED FOR REFERENCE ONLY, MARANTZ WILL NOT SUPPLY THESE PARTS.

3. Taking out the disc

1. Release 7 screws.
2. Lift the top case with holding the back of it and remove backward.
3. Turn the (A) portion to the direction of arrow (B).
4. Then the tray is moved a little. Pull the tray with your hand at this time.

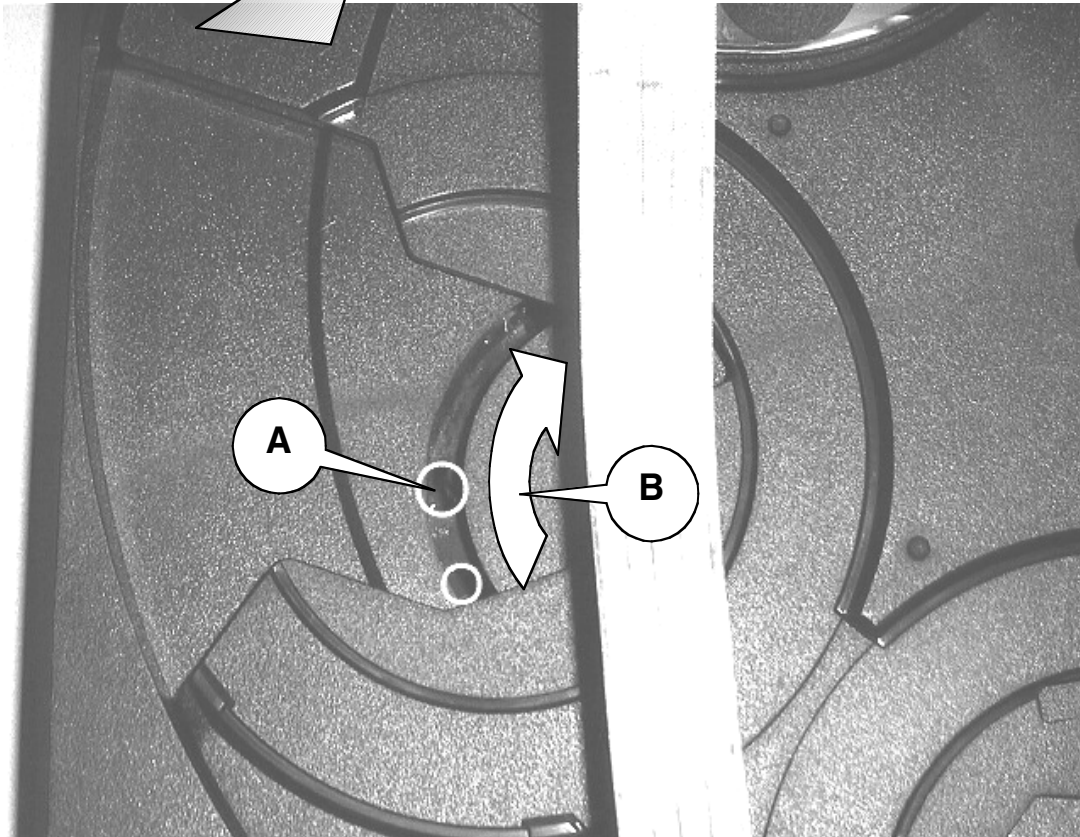
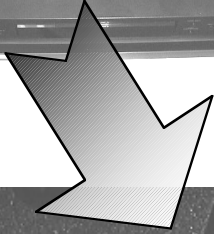
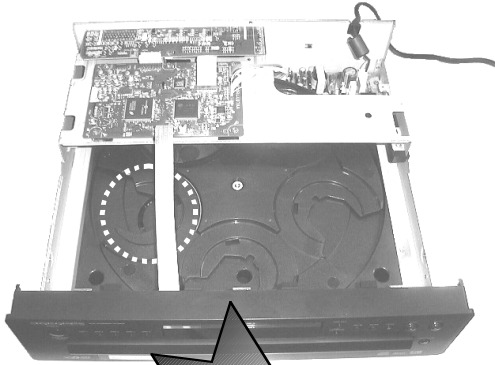

10. ELECTRICAL TROUBLESHOOTING GUIDE

1. Power(SMPS) Circuit

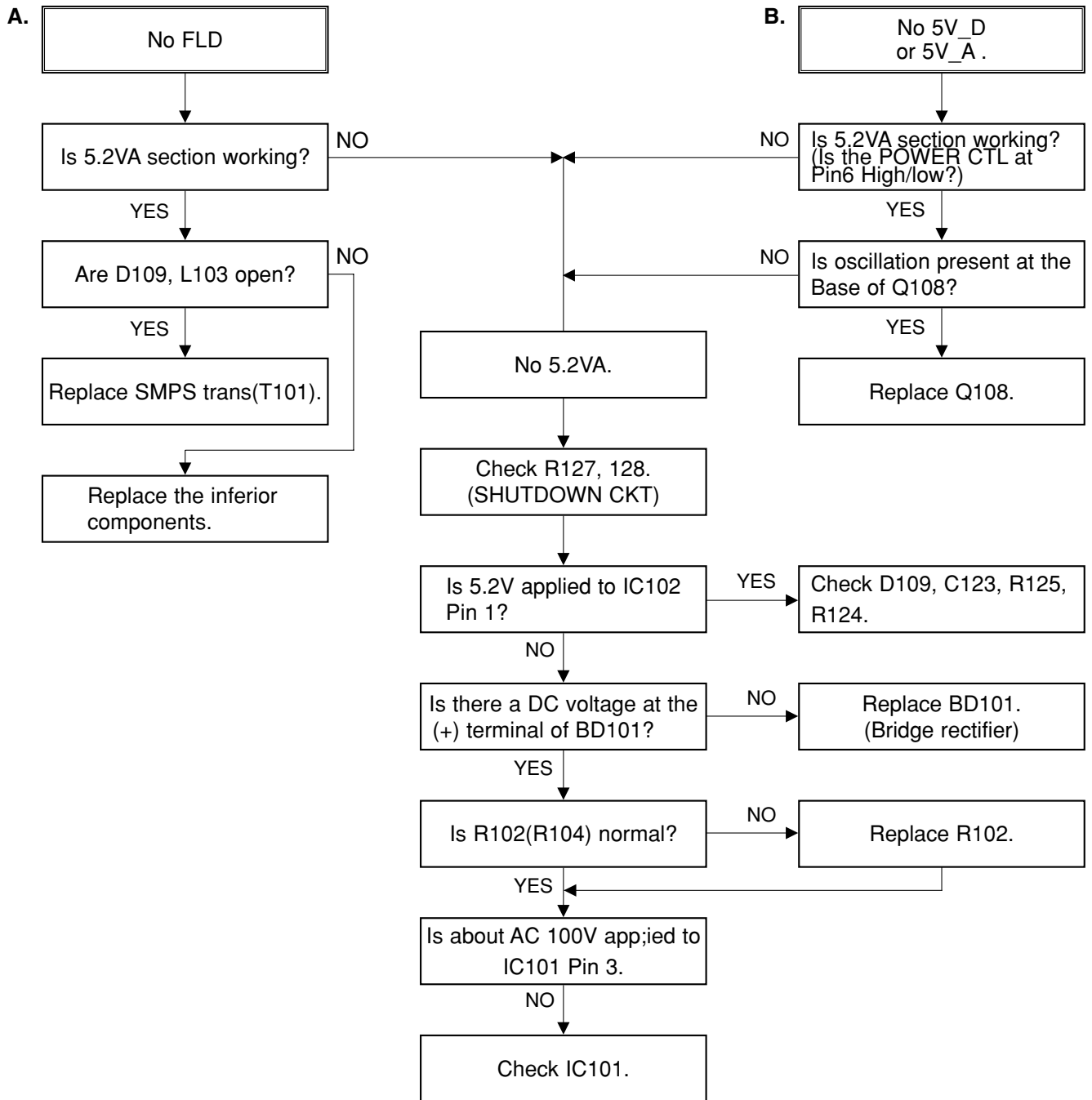

2. μ -COM Circuit

A. No Power

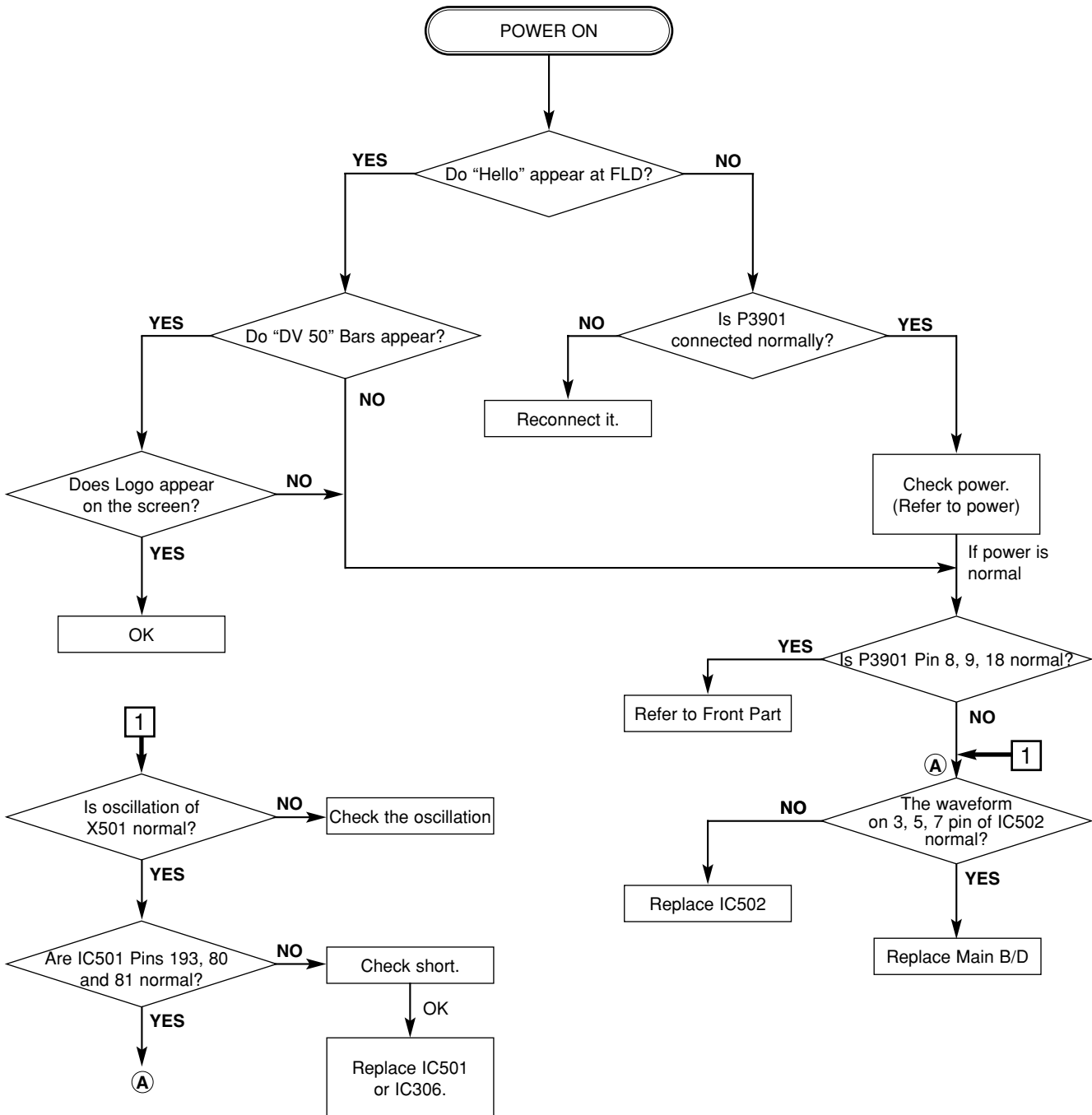

B. Audio abnormal

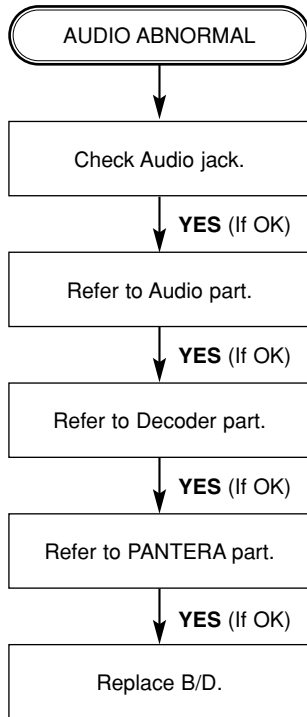

C. Video abnormal

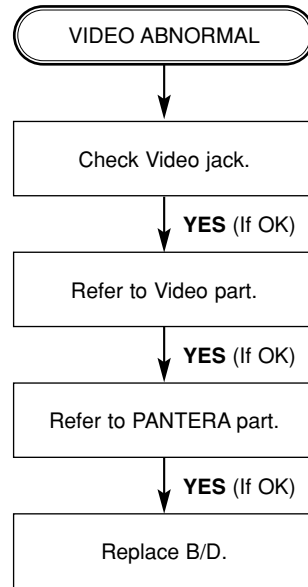

D. Open/Close abnormal

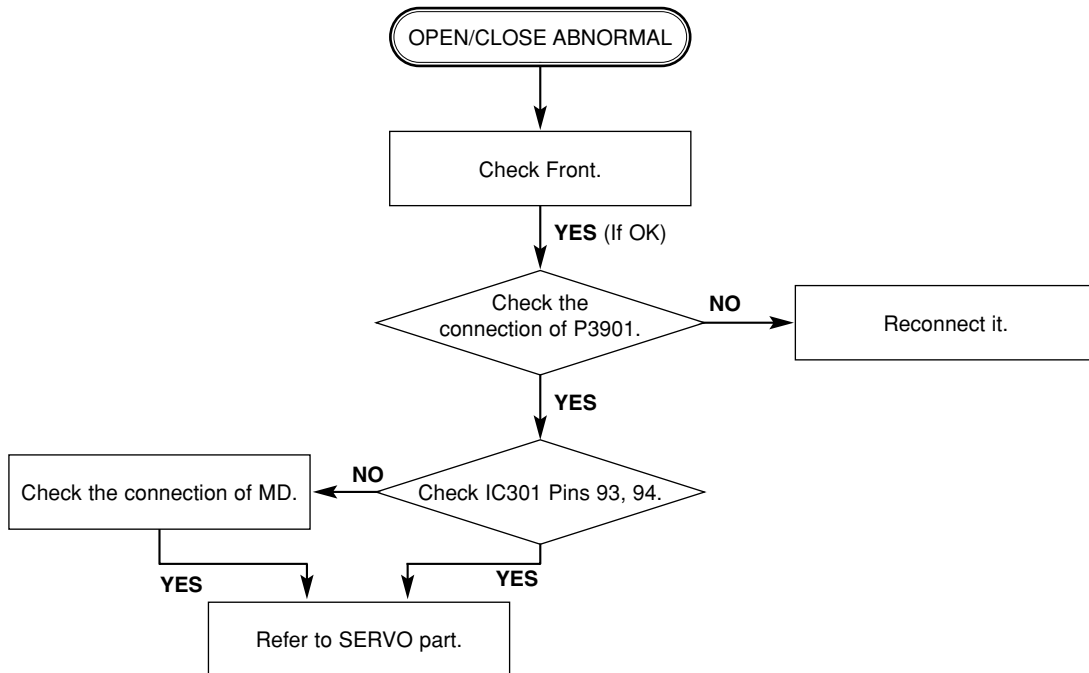

E. Picture abnormal

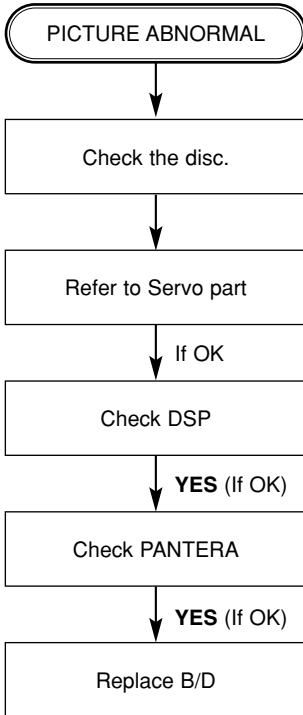

F. Disc Error

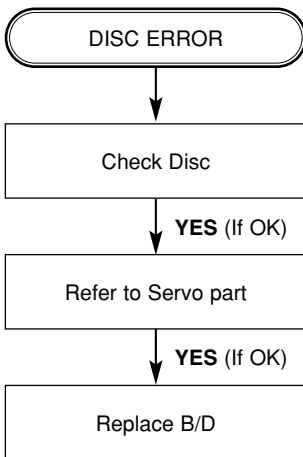

3. PANTERA Circuit

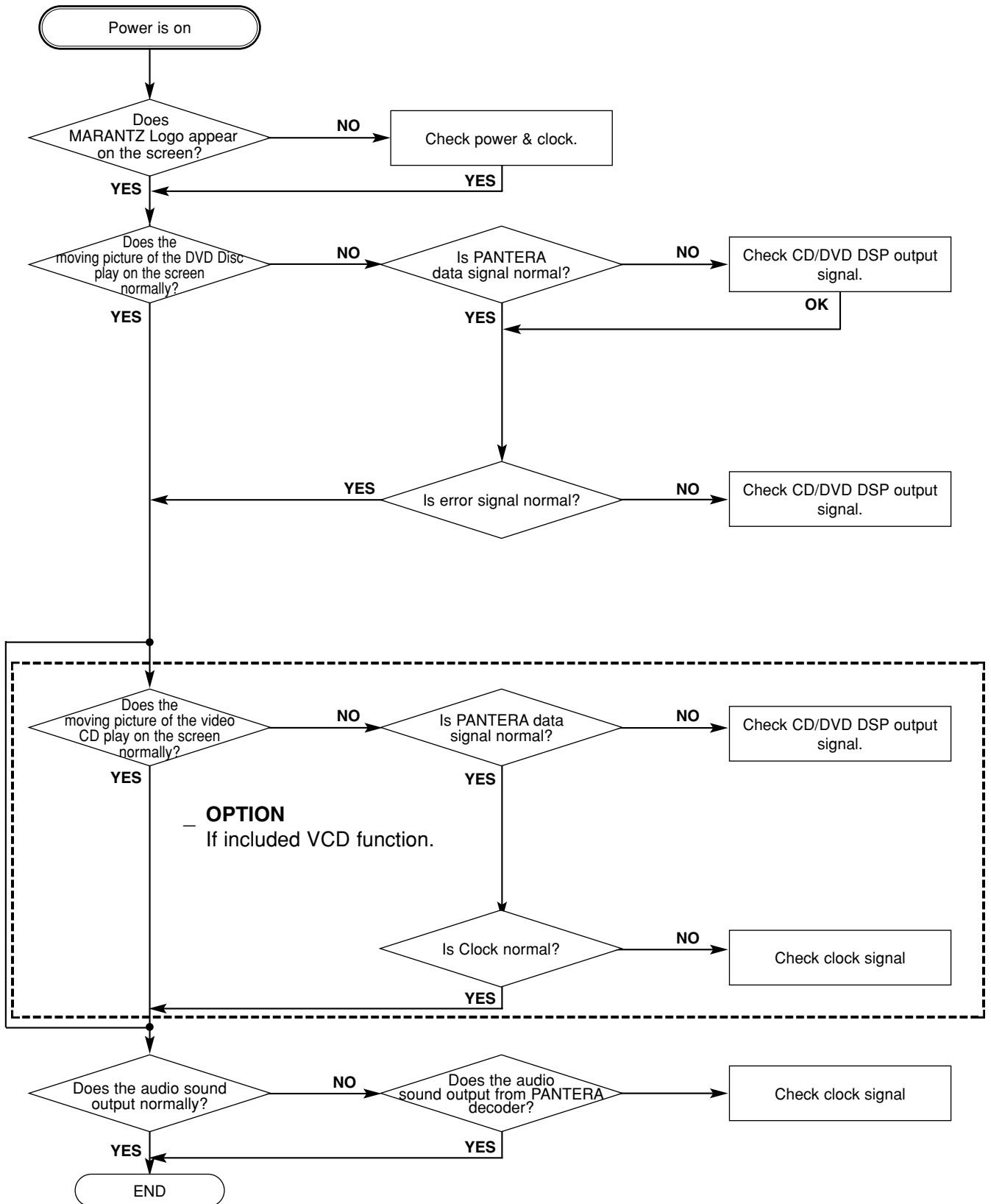

4. Front Circuit (Digitron & key)

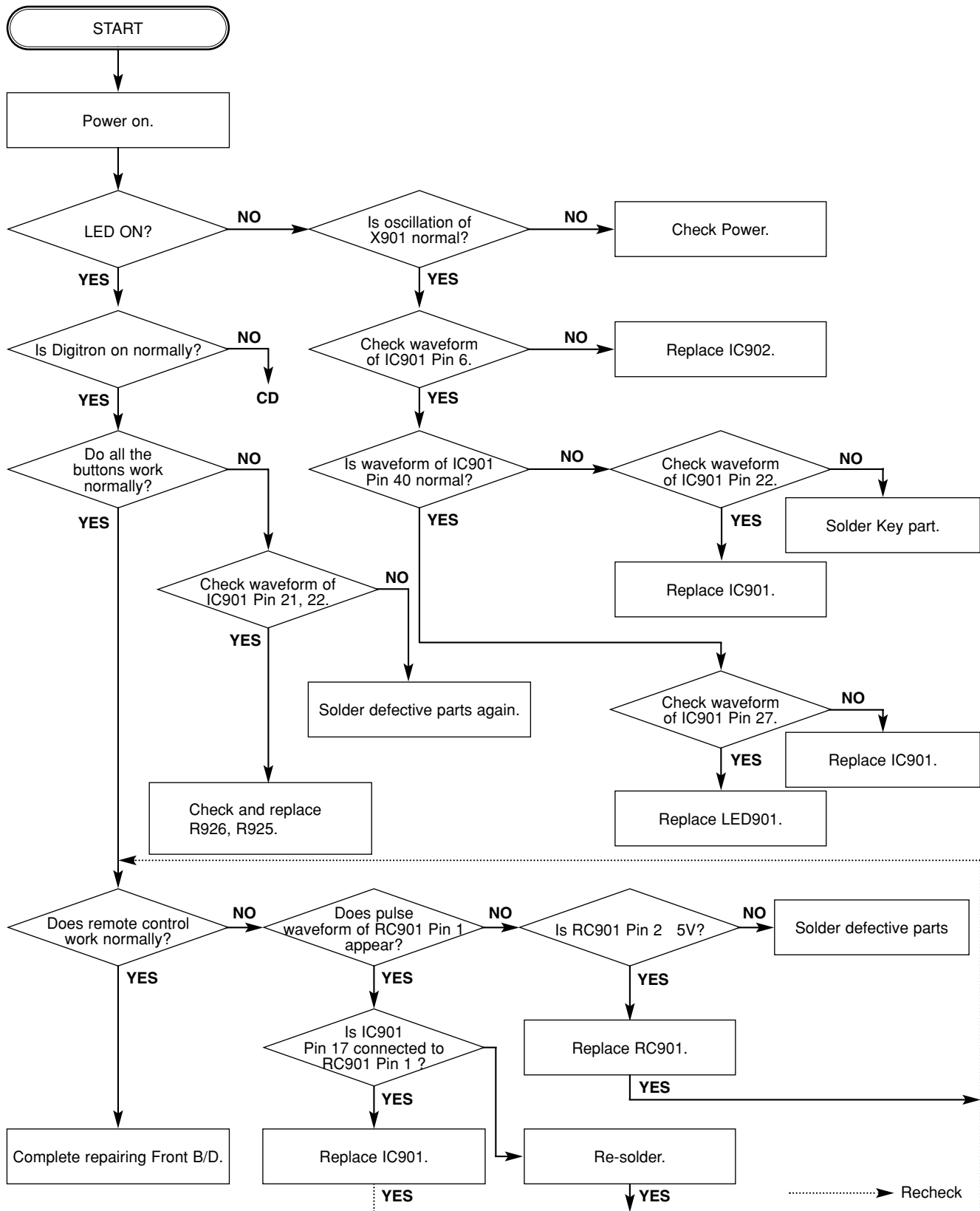

B.

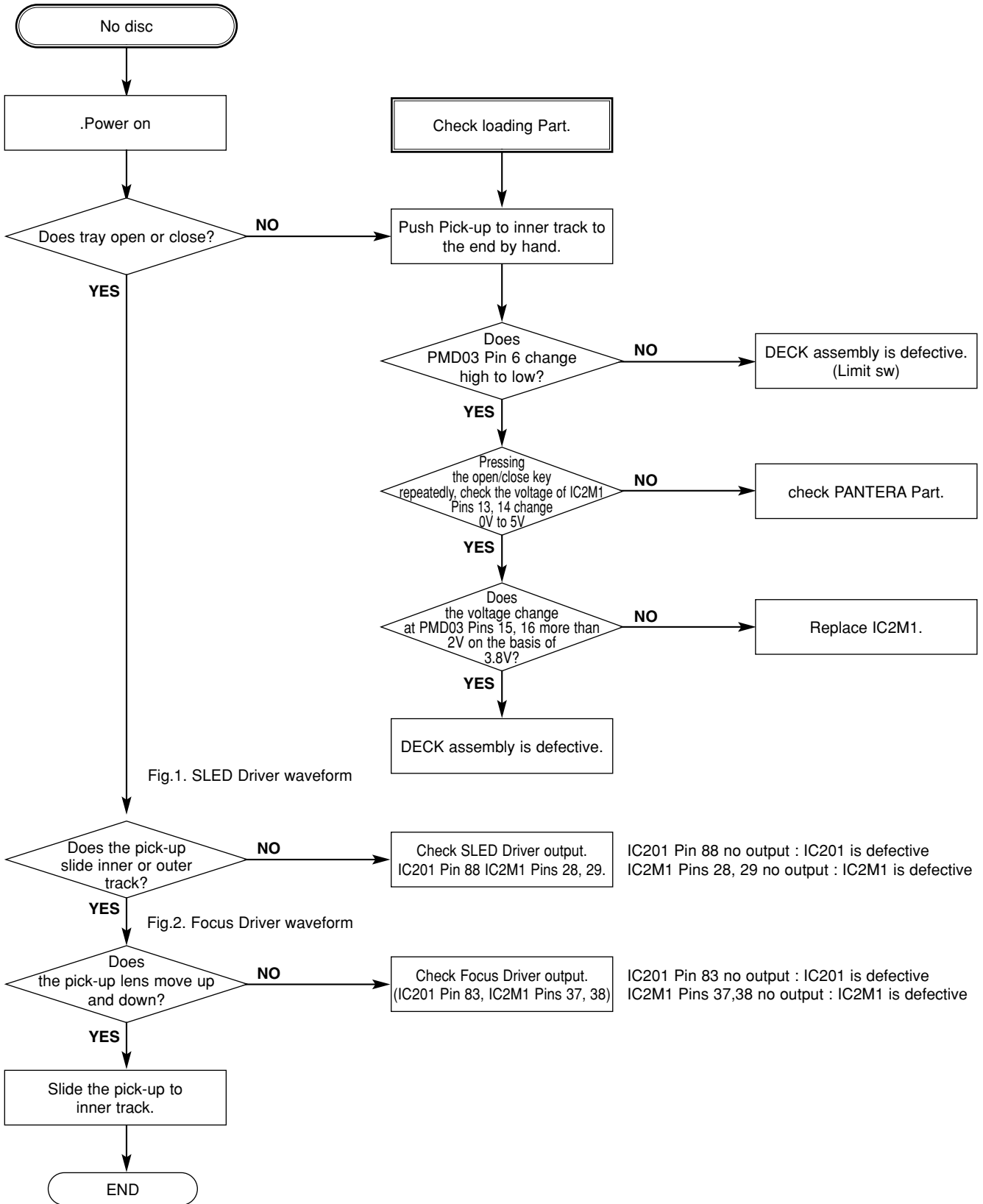

C.

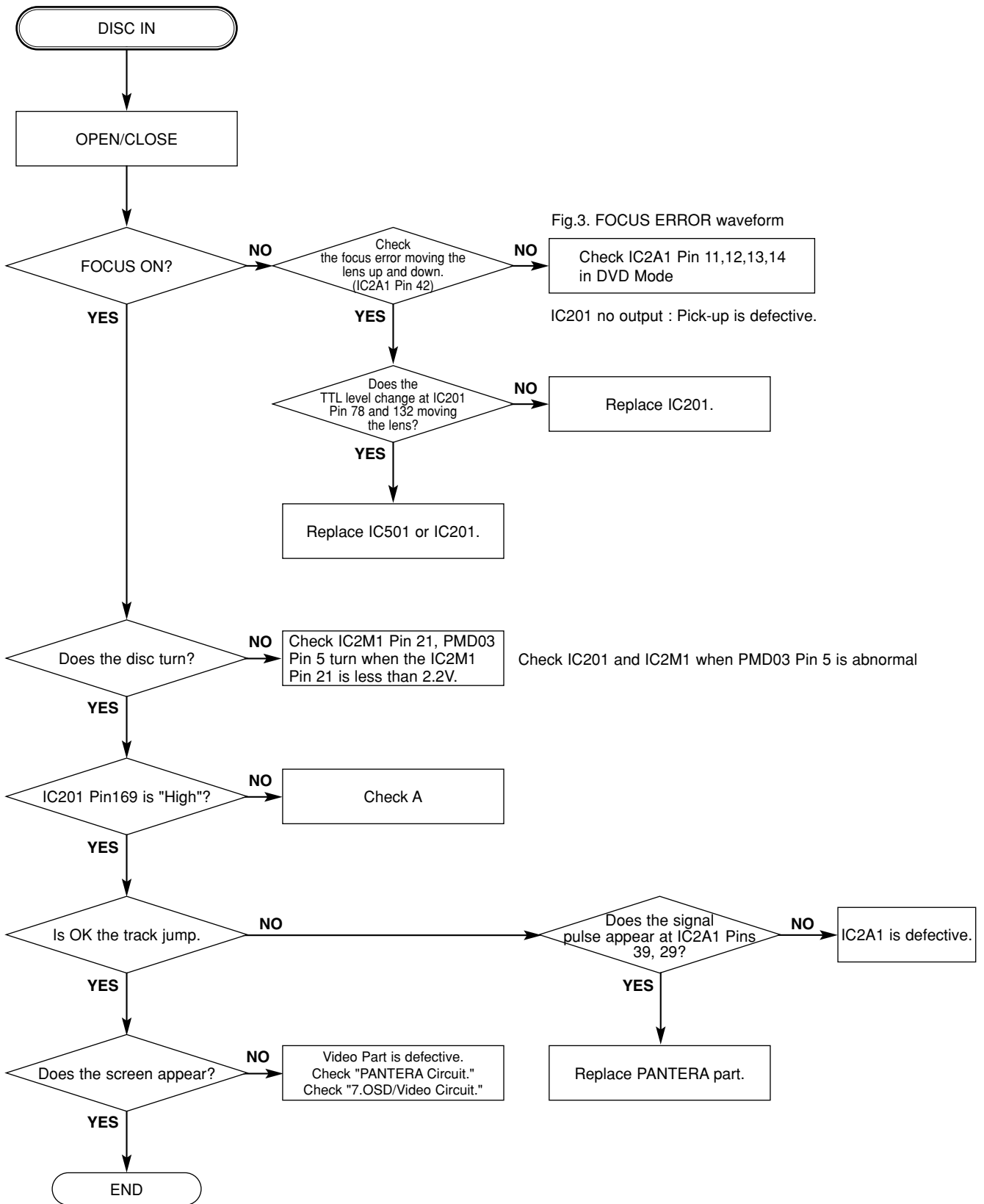

D.

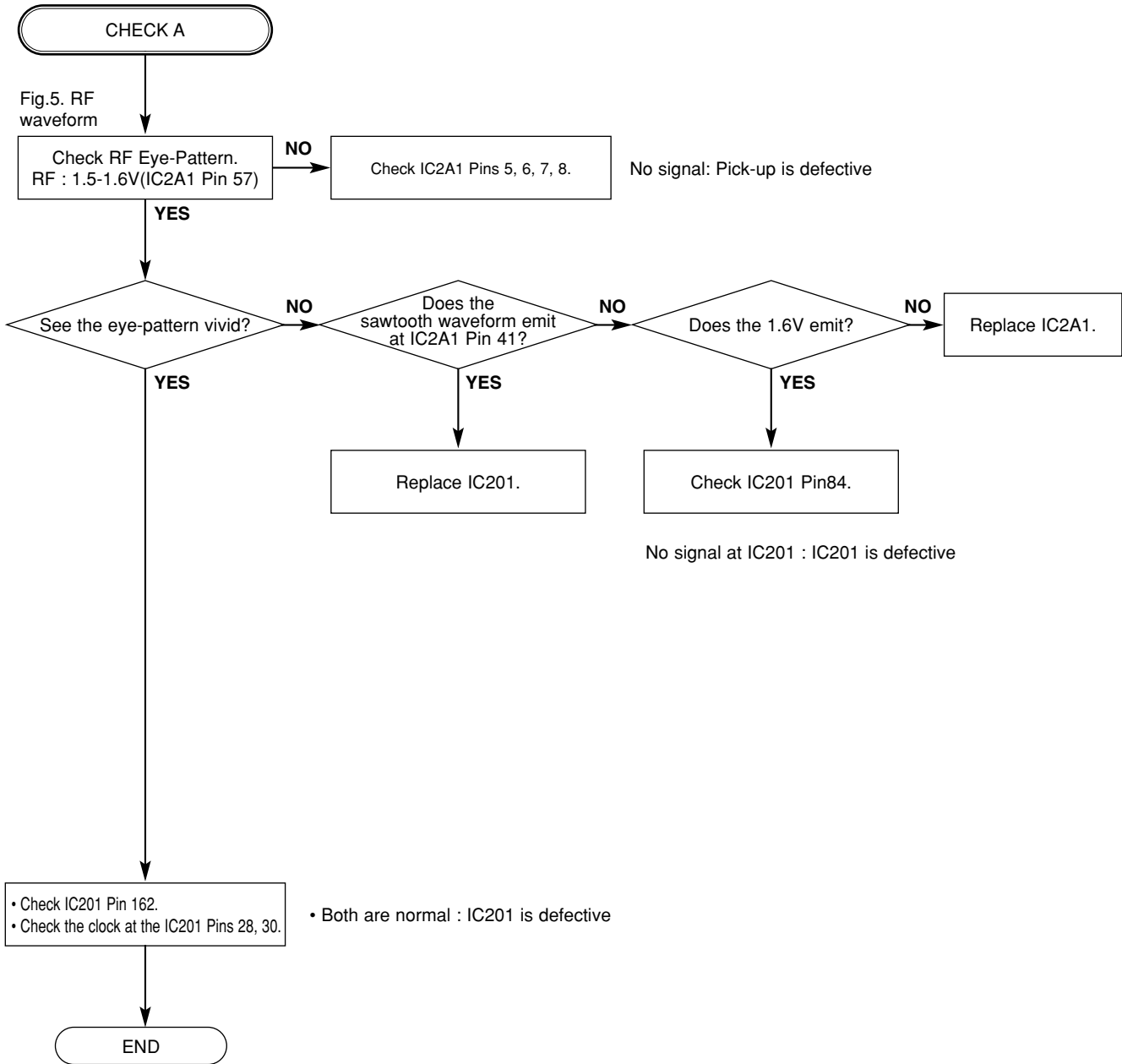

11. BLOCK DIAGRAM

1. Overall Block Diagram

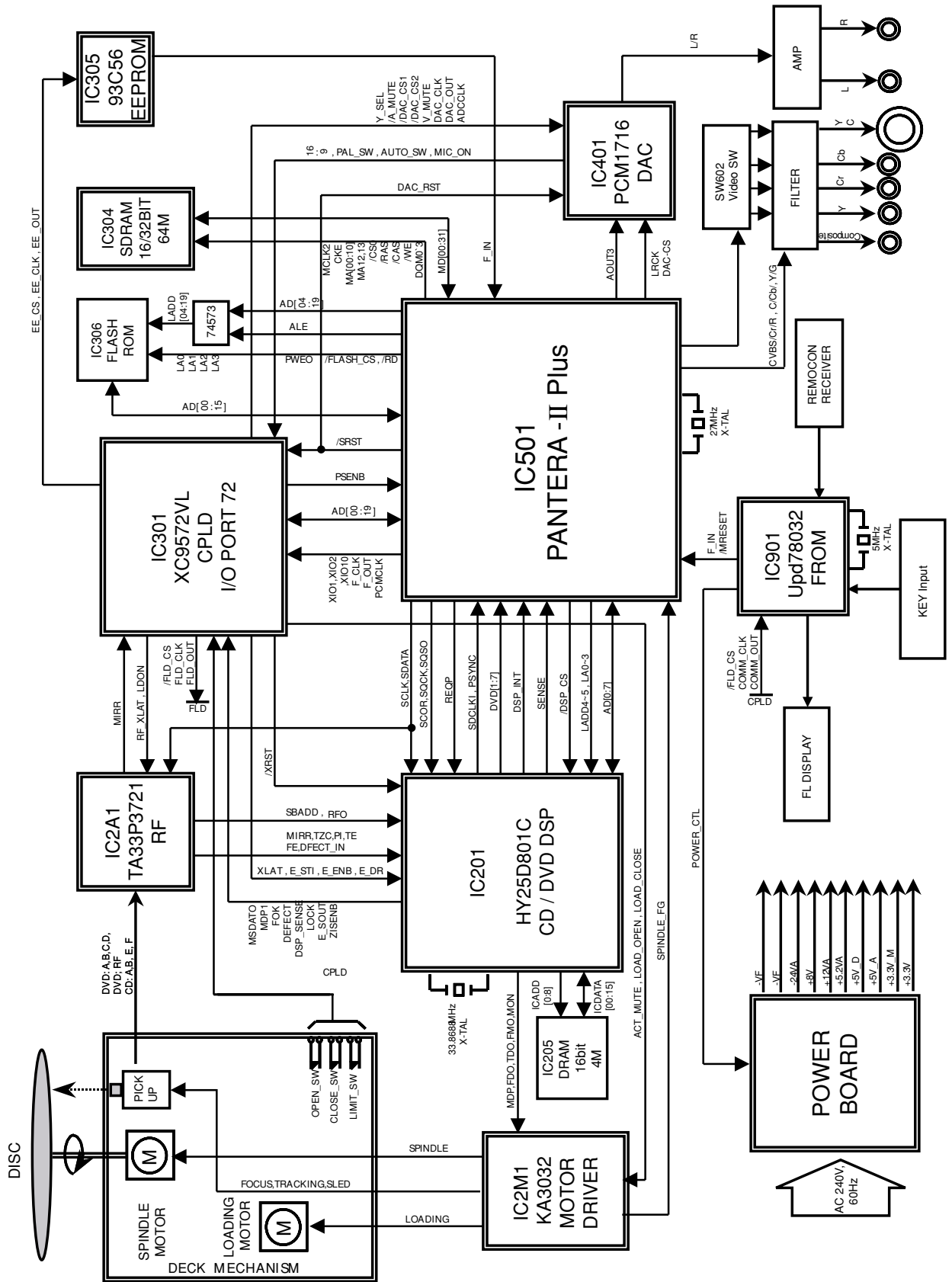

2. Power(SMPS) Block Diagram

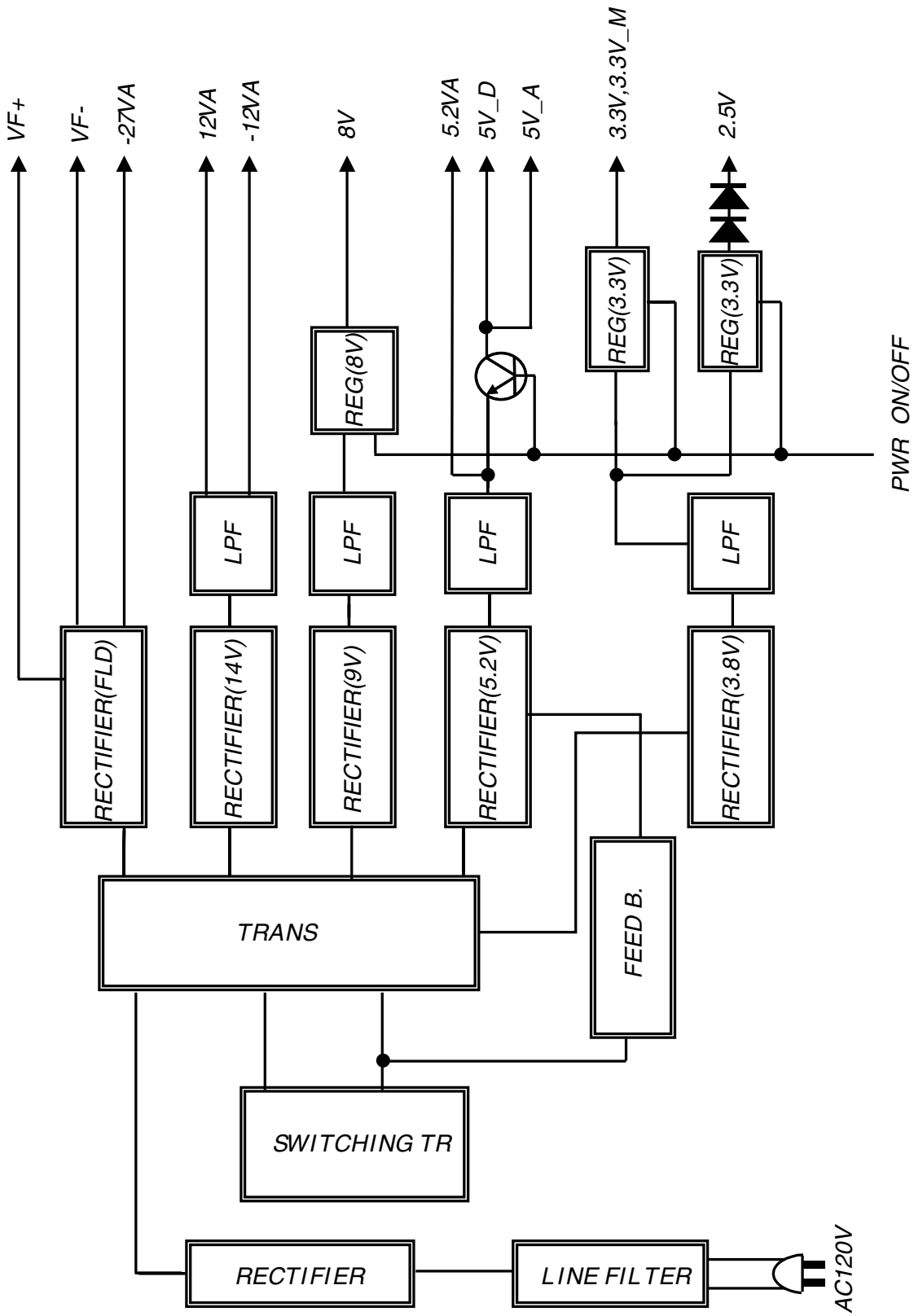

3. RF/CD DSP/DVD DSP/DVD SERVO Block Diagram

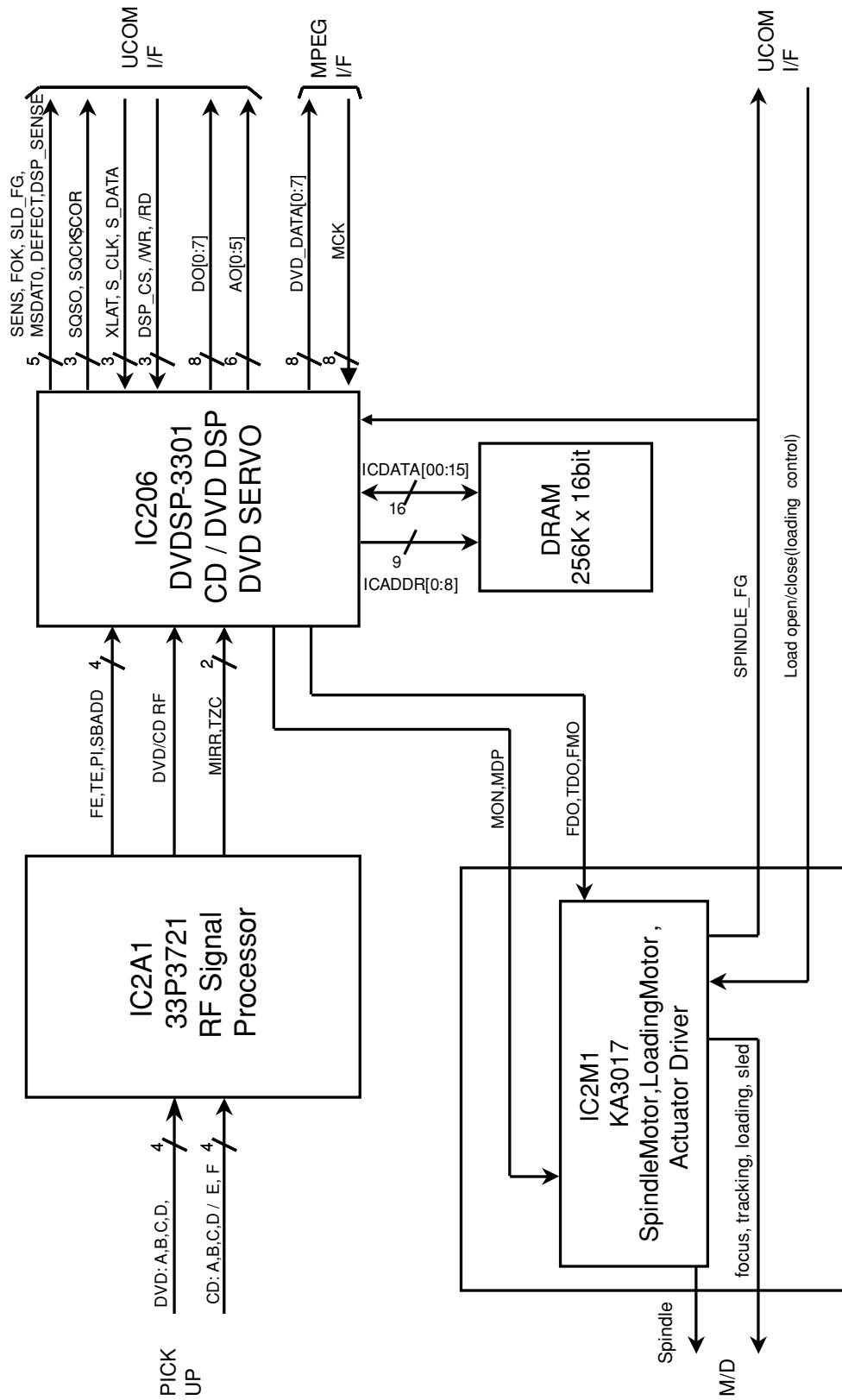

4. Audio Block Diagram

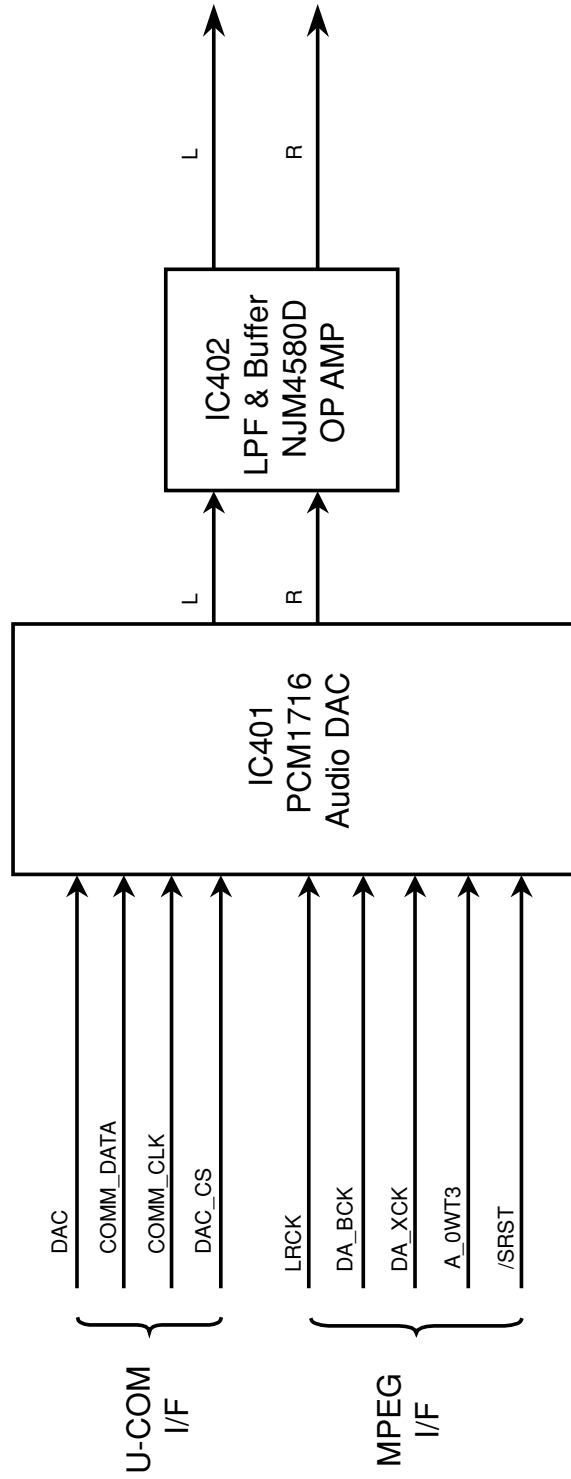

5. MPEG Block Diagram

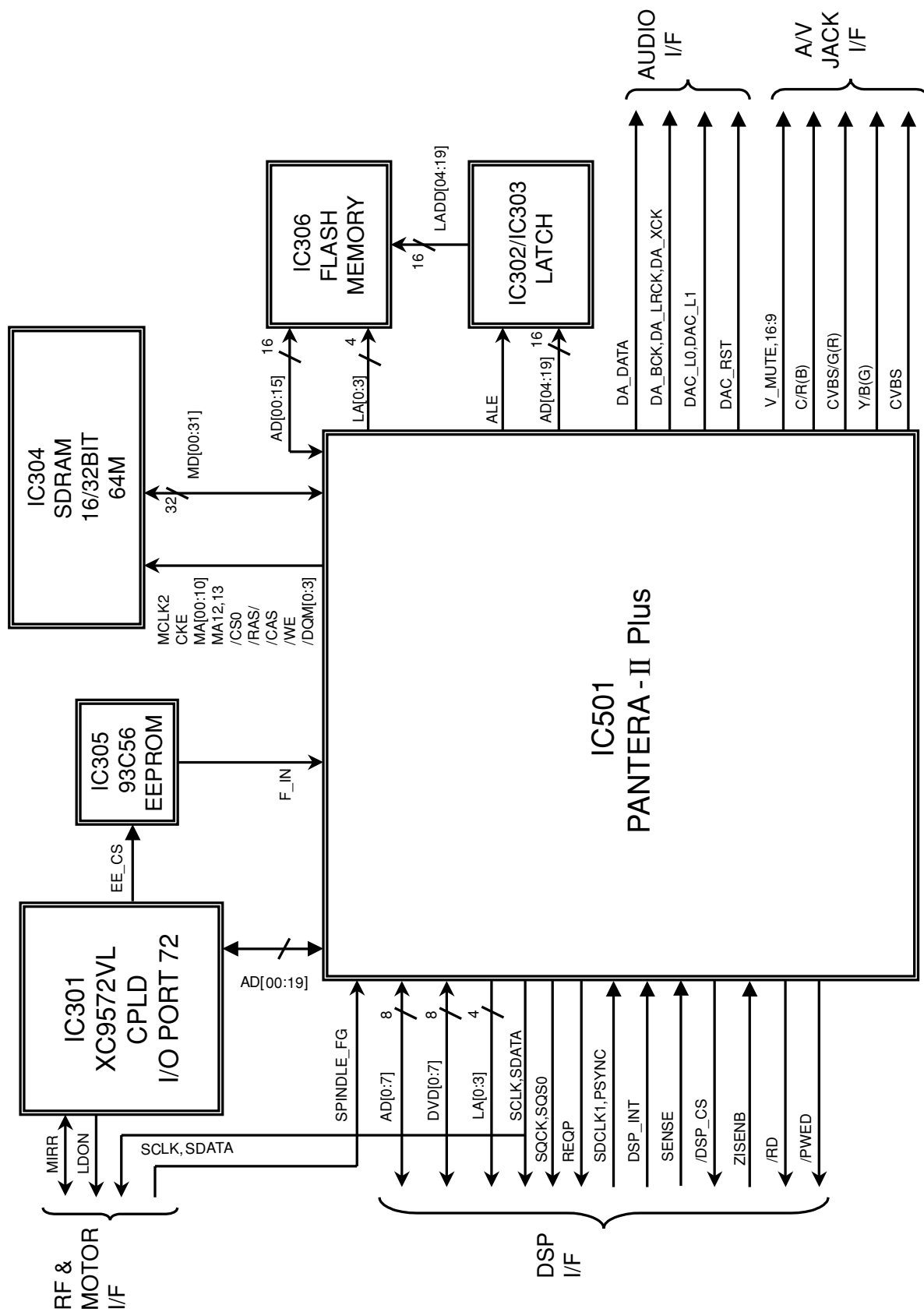

12. CIRCUIT DIAGRAM

1. POWER(SMPS) CIRCUIT DIAGRAM

NOTE :
 1. Shaded(■) parts are critical for safety. Replace only with specified part number.
 2. Voltages are DC-measured with a digital voltmeter during Play mode.

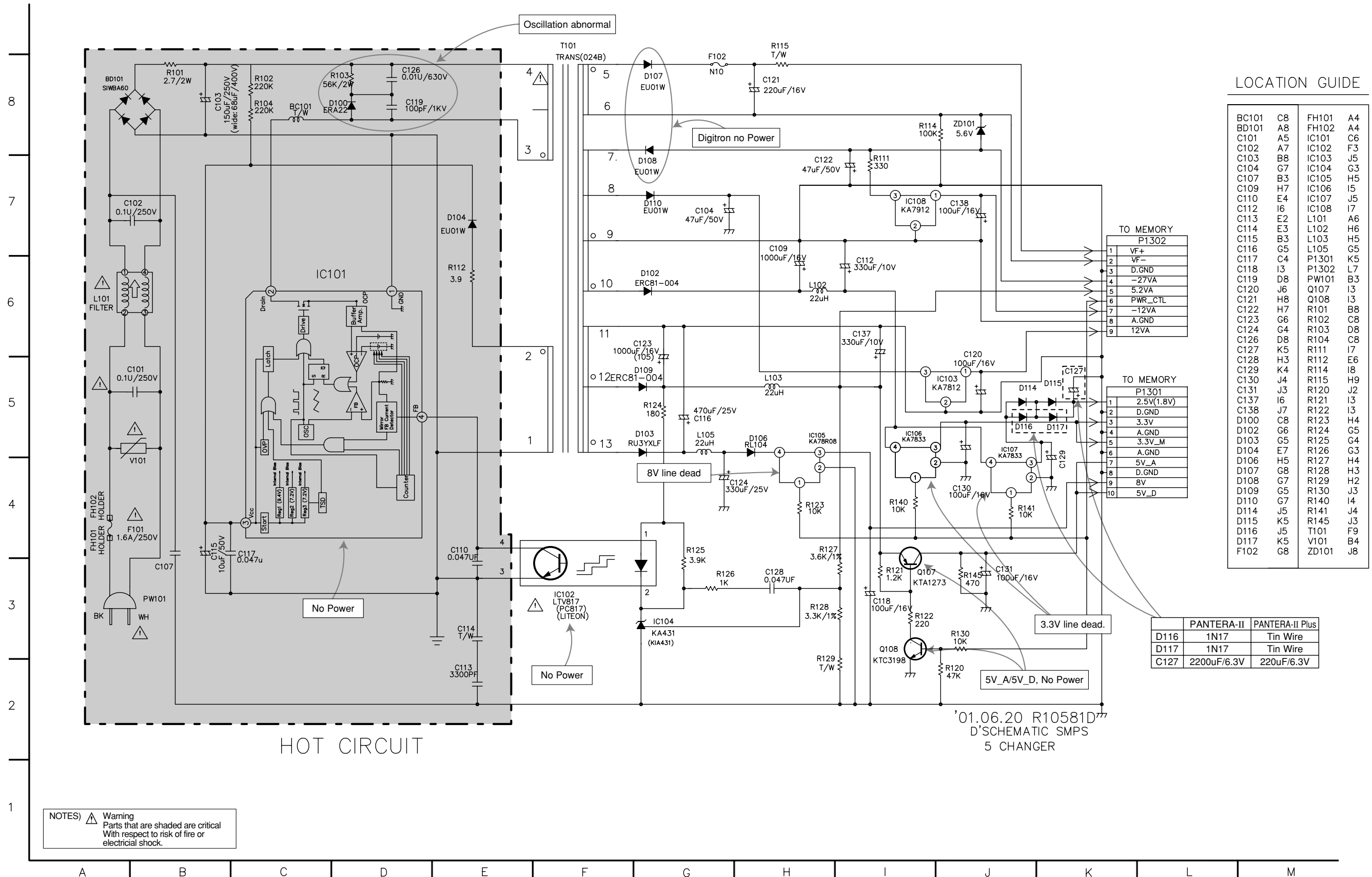

2. DVD DSP CIRCUIT DIAGRAM

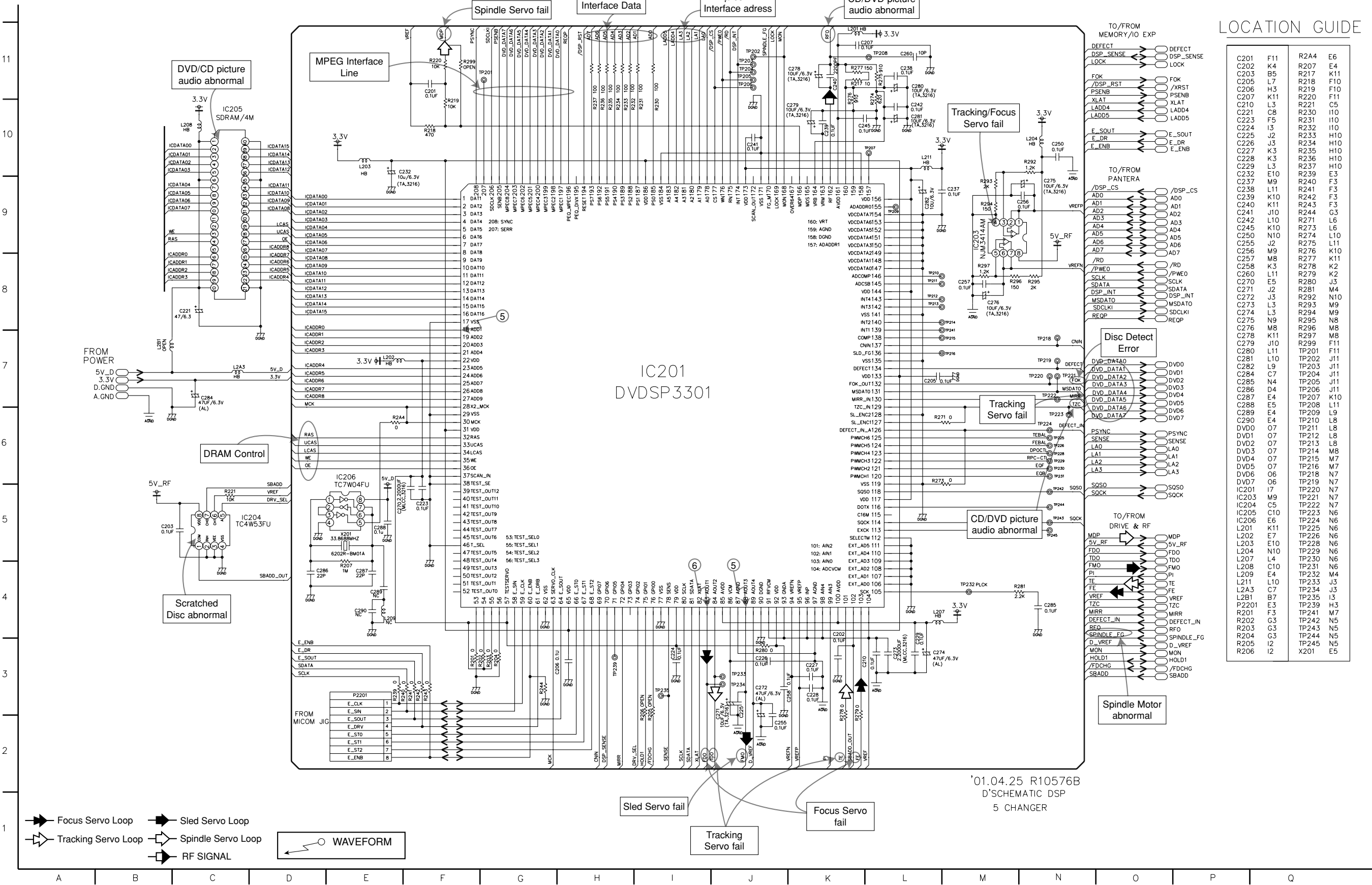

3. DRIVE & RF CIRCUIT DIAGRAM

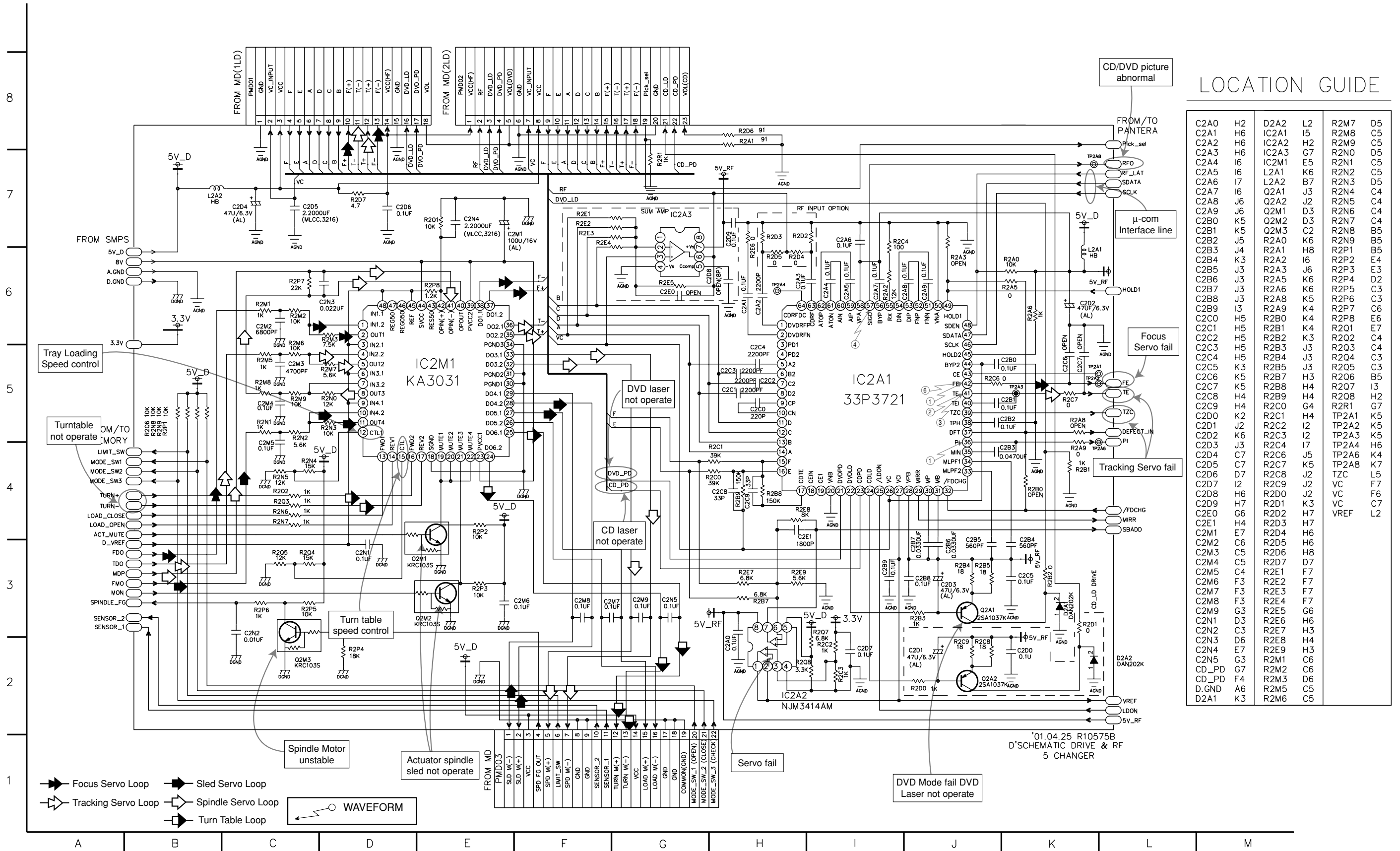

• WAVEFORMS

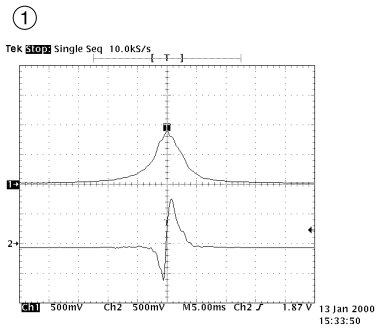

IC2A1 Pin 42, Focus Error
IC2A1 Pin 36, Pi

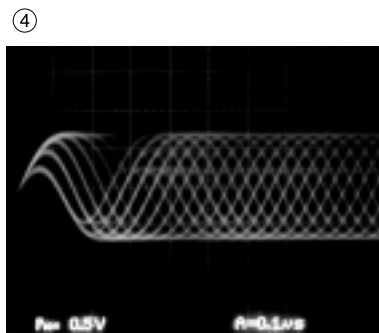

IC2A1 Pin 57, RF

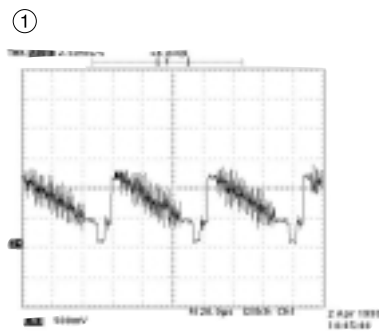

IC501 Pin 118, Composite

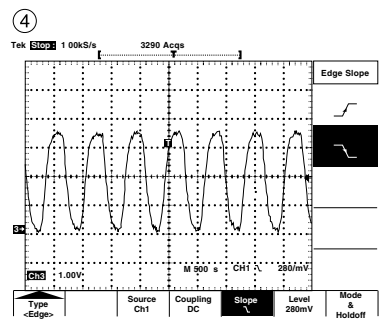

IC501 Pin 99, PANTER MAIN

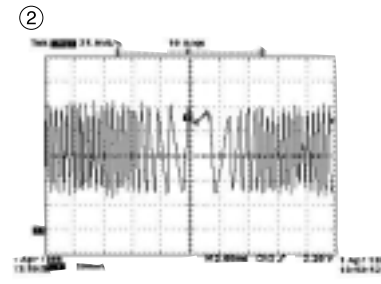

IC2A1 Pin 41 Tracking Error

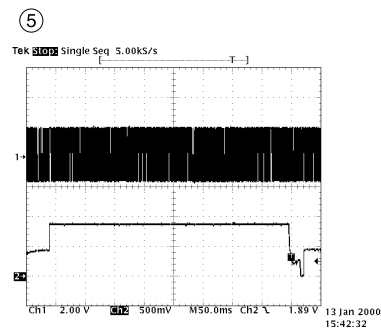

IC201 Pin 88, SLED Drive(FMO)
IC201 Pin 18, SLED FG

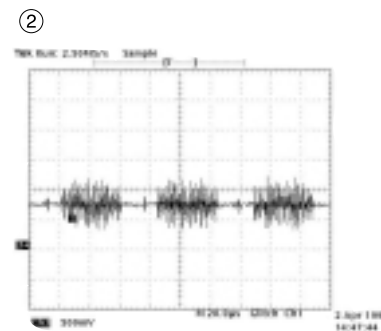

IC501 Pin 112, Chrominance (Super video out Mode)

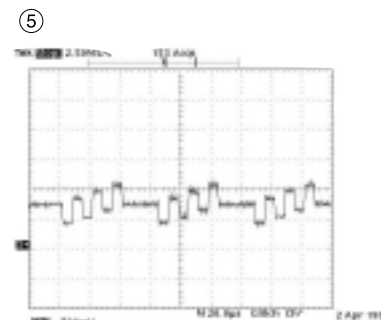

IC501 Pin 112 Component Pb

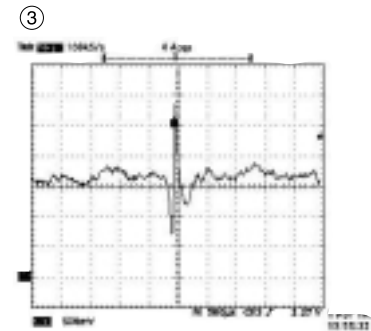

IC2A1 Pin 41 VBR TRACKING Error

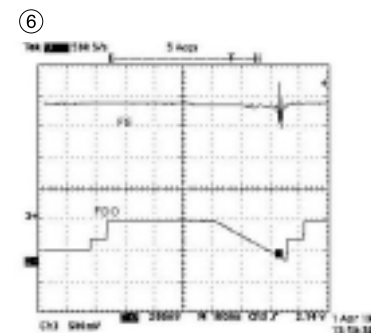

IC2A1 Pin42, Focus Error(in Focus Search)
IC201 Pin 83, Focus Drive(FDO)

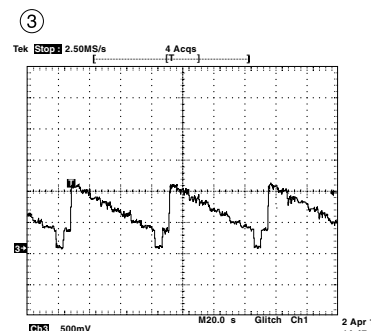

IC501 Pin 114, Luminance (Super video out Mode)

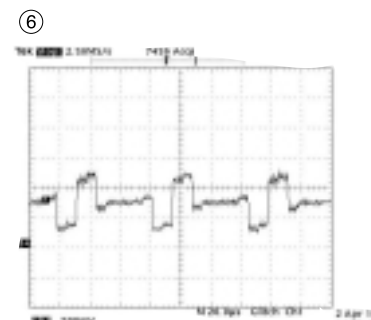

IC501 Pin 110 Component Pr

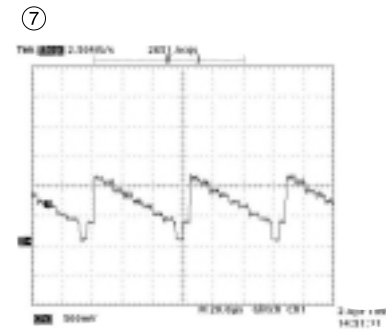

IC501 Pin 114 Component Y

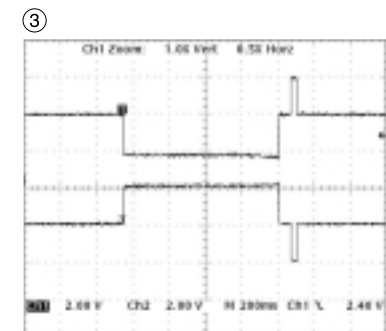

TURN(+)(-) from Motor Drive Reverse turn

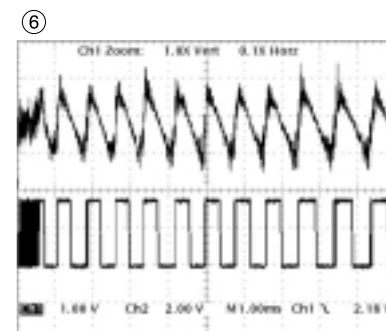

TE/TZC Before tracking servo ON

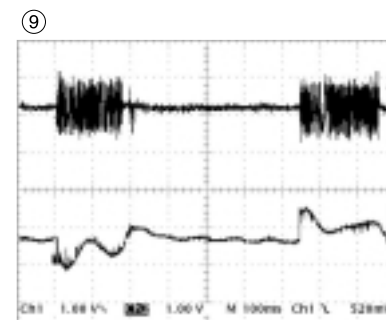

TE/SLD(+) Search mode (outer & inner)

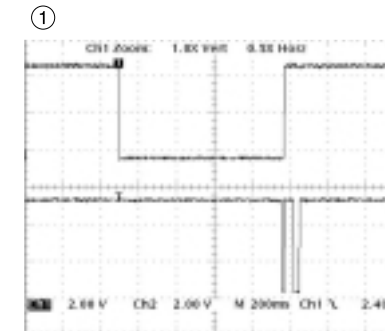

TURN(+)(-) Signal from μ -com

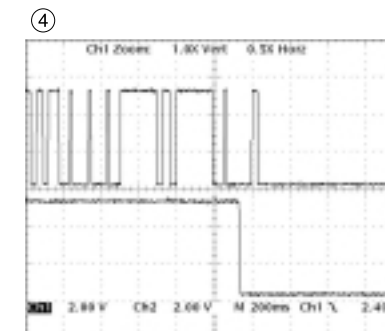

Sensor 1 (disc position)
Sensor 2 (disc ready)

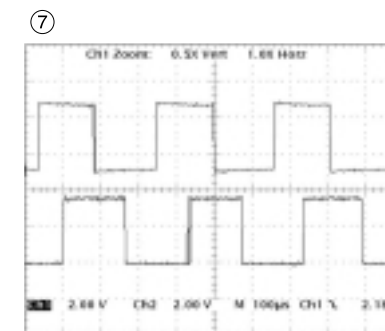

TZC/MIRR (Search mode)

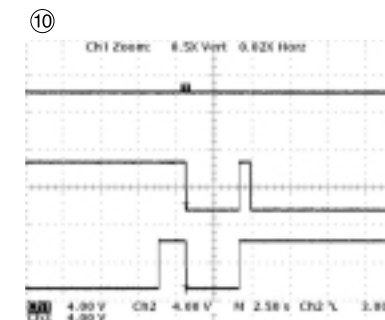

Tray open Tray closed

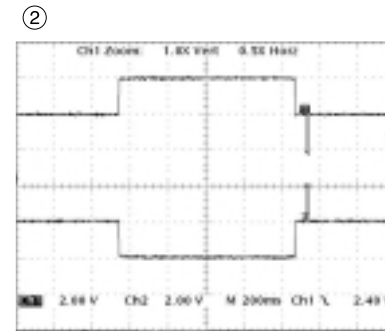

TURN(+)(-) from Motor Drive Forward turn

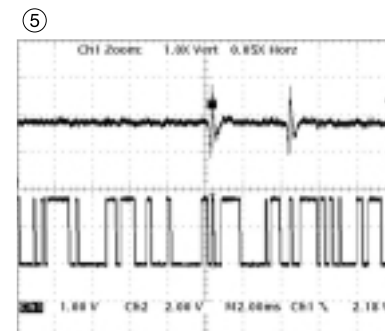

TE/TZC After tracking servo ON (Play mode)

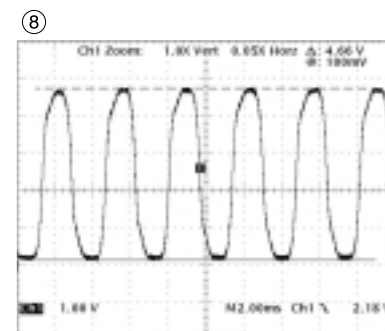

FG Signal from M/D (Play mode)

5. MEMORY CIRCUIT DIAGRAM

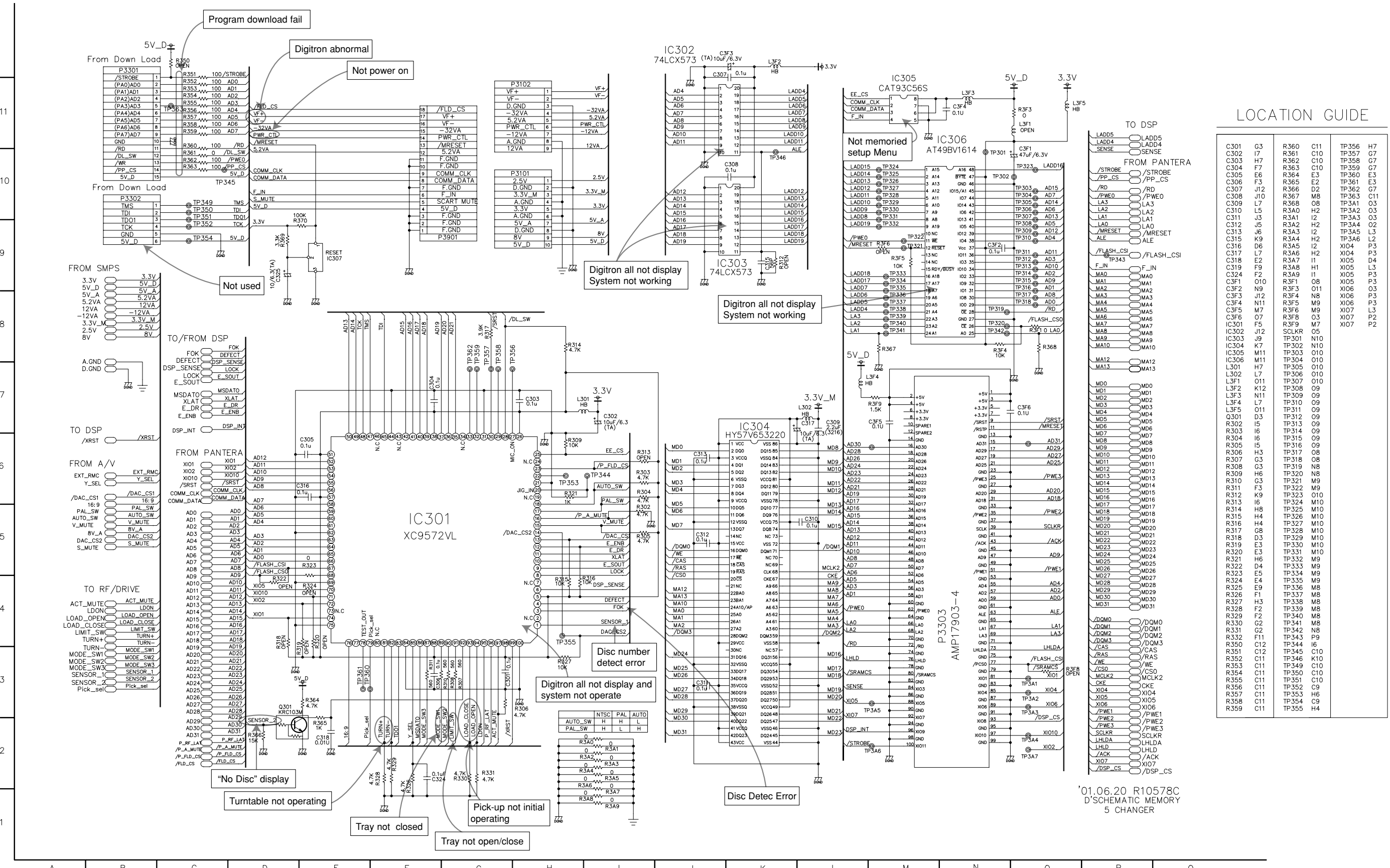

LOCATION GUIDE

C301	G3	R360	C11	TP356	H7
C302	I7	R361	C10	TP357	G7
C303	H7	R362	C10	TP358	G7
C304	F7	R363	C10	TP359	G7
C305	E6	R364	E3	TP360	E3
C306	F3	R365	E2	TP361	E3
C307	J12	R366	D2	TP362	G7
C308	J10	R367	M8	TP363	C11
C309	L7	R368	H8	TP3A1	O3
C310	L5	R369	O2	TP3A2	O3
C311	J3	R3A1	I2	TP3A3	O3
C312	J5	R3A2	H2	TP3A4	O2
C313	J6	R3A3	I2	TP3A5	L3
C315	K9	R3A4	H2	TP3A6	L2
C316	D6	R3A5	I2	XI04	P3
C317	L7	R3A6	H2	XI04	P3
C318	E2	R3A7	I1	XI05	D4
C319	F9	R3A8	H1	XI05	L3
C324	F2	R3A9	H1	XI05	P3
C3F1	O10	R3F1	O8	XI05	P3
C3F2	N9	R3F3	O11	XI06	O3
C3F4	I12	R3F4	N8	XI06	P3
C3F5	M11	R3F5	M9	XI07	L3
C3F6	O7	R3F8	O3	XI07	P2
IC301	F5	R3F9	M7	XI07	P2
IC302	J2	SCLKR	O5		
IC303	J9	TP301	N10		
IC304	K7	TP302	N10		
IC305	M11	TP303	O10		
IC306	M11	TP304	O10		
L301	H7	TP305	O10		
L302	L7	TP306	O10		
L3F1	O11	TP307	O10		
L3F2	I12	TP308	O9		
L3F3	N11	TP309	O9		
L3F4	L7	TP310	O9		
L3F5	O11	TP311	O9		
Q301	D3	TP312	O9		
R302	I5	TP313	O9		
R303	I6	TP314	O9		
R304	I6	TP315	O9		
R305	I5	TP316	O9		
R306	H3	TP317	O8		
R307	G3	TP318	O8		
R308	G3	TP319	N8		
R309	H6	TP320	N8		
R310	G3	TP321	M9		
R311	F3	TP322	M9		
R312	K9	TP323	O10		
R313	I6	TP324	M10		
R314	H8	TP325	M10		
R315	H4	TP326	M10		
R316	H4	TP327	M10		
R317	G8	TP328	M10		
R318	D3	TP329	M10		
R319	E3	TP330	M10		
R320	E3	TP331	M10		
R321	H6	TP332	M9		
R322	D4	TP333	M9		
R323	E5	TP334	M9		
R324	E4	TP335	M9		
R325	E9	TP336	M8		
R326	F1	TP337	M8		
R327	H3	TP338	M8		
R328	F2	TP339	M8		
R329	F2	TP340	M8		
R330	G2	TP341	M8		
R331	G2	TP342	N8		
R332	F11	TP343	P9		
R350	C12	TP344	I6		
R351	C12	TP345	C10		
R352	C11	TP346	K10		
R353	C11	TP349	C10		
R354	C11	TP350	C10		
R355	C11	TP351	C10		
R356	C11	TP352	C9		
R357	C11	TP353	H6		
R358	C11	TP354	C9		
R359	C11	TP355	H4		

'01.06.20 R10578C
D'SCHEMATIC MEMORY
5 CHANGER

6. TIMER & KEY CIRCUIT DIAGRAM

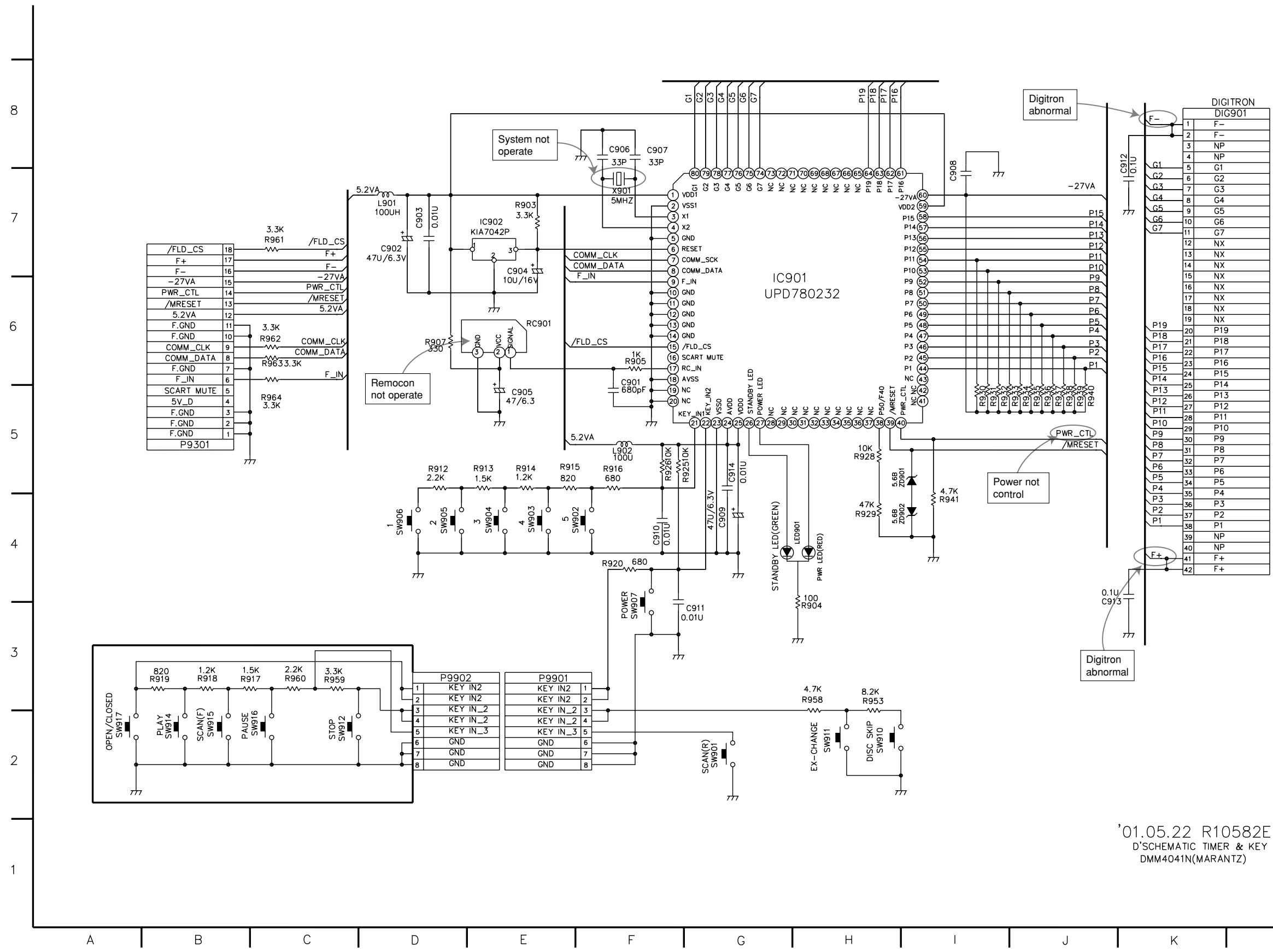

LOCATION GUIDE

C901	F6
C902	D7
C903	D7
C904	E7
C905	E5
C906	F8
C907	F8
C908	I7
C909	G4
C910	F4
C911	G3
C912	K7
C913	J3
C914	G5
IC901	G6
IC902	E7
L901	D7
L902	F5
LED901	H4
P9301	B5
P9901	E3
P9902	D3
PWR_CTLJ5	
PWR_CTLK6	
R903	E7
R904	H3
R905	F6
R907	D6
R912	D5
R913	E5
R914	E5
R915	E5
R916	F5
R917	B3
R918	B3
R919	B3
R920	F4
R925	G5
R926	F5
R928	H5
R929	H4
R930	I5
R931	I5
R932	I5
R933	J5
R934	J5
R935	J5
R936	J5
R937	J5
R938	J5
R939	J5
R940	J5
R941	I4
R953	H3
R958	H3
R959	C3
R960	C3
R961	C7
R962	C6
R963	C6
R964	C5
RC901	E6
SW901	G2
SW902	F4
SW903	E4
SW904	E4
SW905	D4
SW906	D4
SW907	F3
SW910	H2
SW911	H2
SW912	C2
SW914	B2
SW915	B2
SW916	C2
SW917	A2
X901	F7
ZD901	I5

'01.05.22 R10582E
 D'SCHEMATIC TIMER & KEY
 DMM4041N(MARANTZ)

7. A/V CIRCUIT DIAGRAM

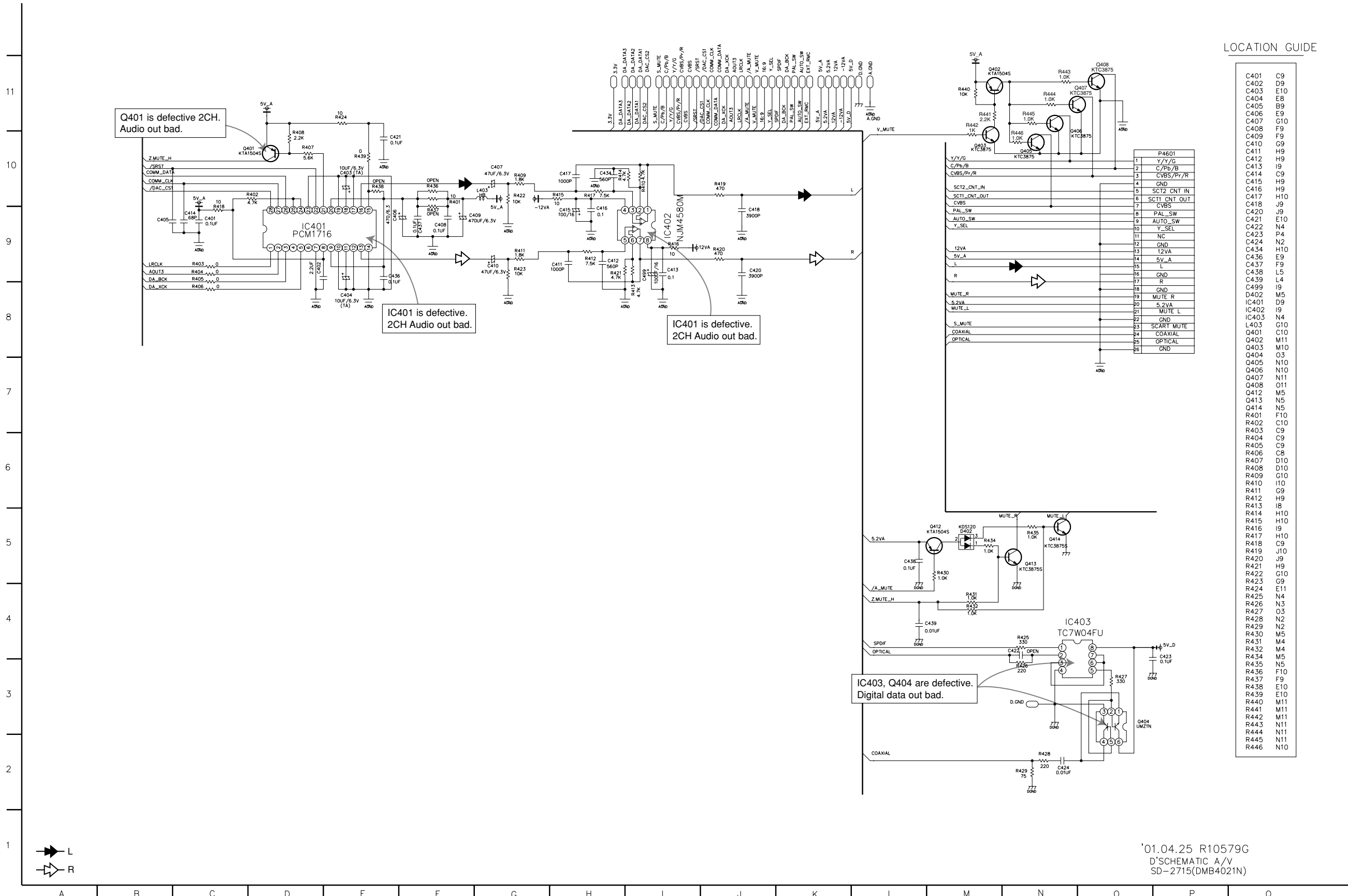

'01.04.25 R10579G
D'SCHEMATIC A/V
SD-2715(DMB4021N)

8. A/V JACK CIRCUIT DIAGRAM

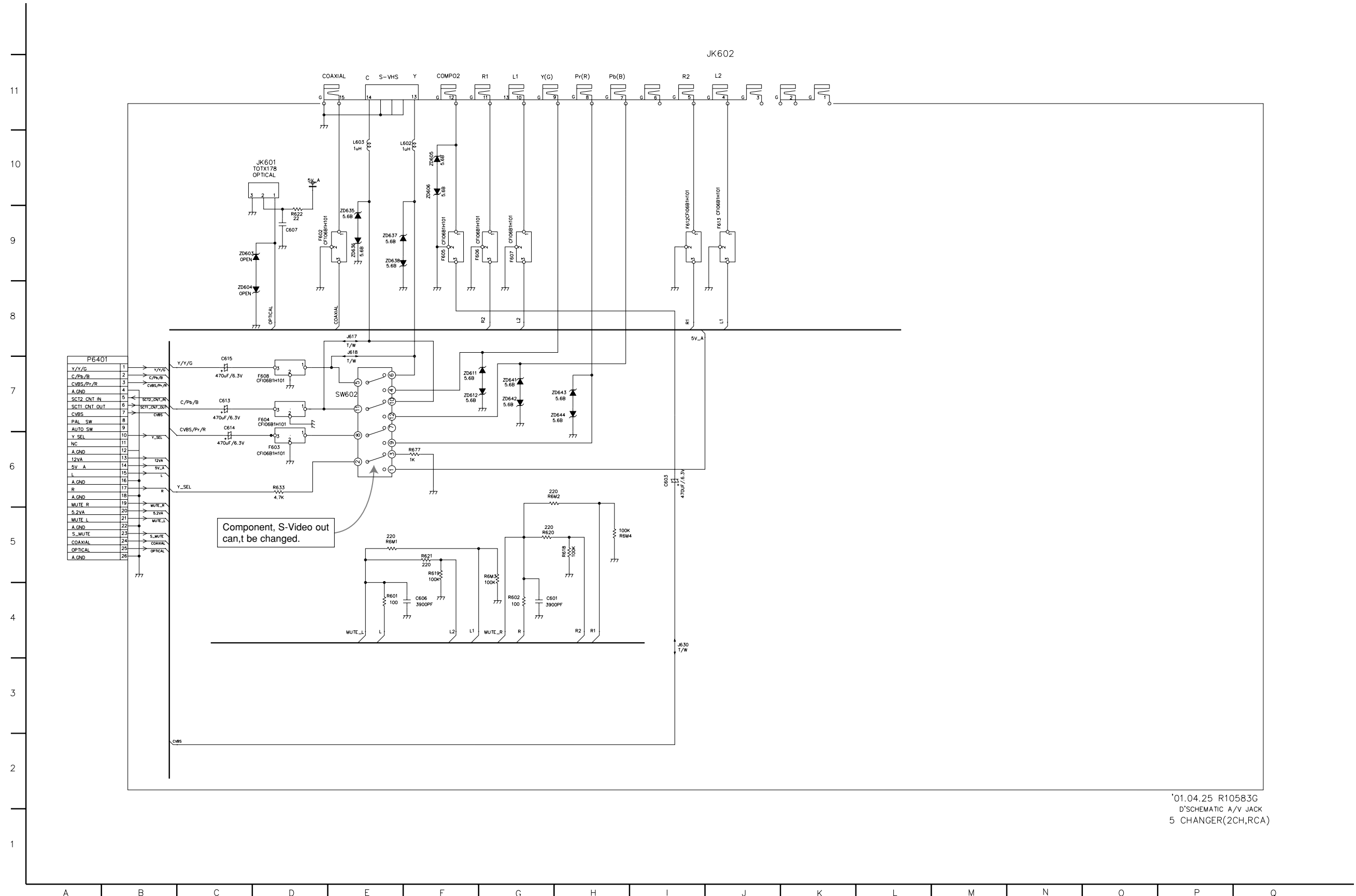

'01.04.25 R10583G
 D'SCHEMATIC A/V JACK
 5 CHANGER(2CH,RCA)

• CIRCUIT VOLTAGE CHART

MODE PIN NO.	LEVEL(V)
PANTERA IC501	
1	3.18
2	1.3
3	1.4
4	2.2
5	1.5
6	0
7	1.5
8	1.4
9	1.6
10	3.1
11	0.7
12	0.15
13	0.15
14	0
15	0
16	1.7
17	1.4
18	0
19	1.5
20	1.6
21	0
22	1.6
23	0
24	3.1
25	1.7
26	1.4
27	3.1
28	1.5
29	0.15
30	
31	0
32	0.7
33	1.5
34	2.2
35	2
36	3.1
37	2.9
38	2.2
39	2.9
40	0
41	0
42	0
43	1.6
44	3.1
45	1.6
46	1.5
47	0
48	1.4
49	0
50	1.5
51	1.7
52	1.2
53	3.1

MODE PIN NO.	LEVEL(V)
54	1.6
55	1.4
56	1.5
57	0
58	1.6
59	1.4
60	1.5
61	1.4
62	3.1
63	1
64	1.5
65	0.005
66	0.5
67	0.003
68	1.58
69	0
70	3.1
71	1.2
72	1.2
73	1.2
74	1.2
75	3.1
76	1.65
77	2.2
78	1.5
79	1.5
80	3.1
81	3.1
82	0.001
83	3.1
84	3.7
85	0
86	
87	3.1
88	3.1
89	2.1
90	0.004
91	3.1
92	0
93	
94	
95	
96	
97	0
98	
99	
100	0
101	2.1
102	3.1
103	0
104	0
105	0
106	0
107	2.1
108	2.1

MODE PIN NO.	LEVEL(V)
109	0
110	0.8
111	0.9
112	1.3
113	3.1
114	0.78
115	0
116	1.26
117	2.38
118	0.08
119	1.2
120	2
121	0
122	3.1
123	3.1
124	3.1
125	3.1
126	
127	
128	
129	
130	
131	
132	0
133	
134	
135	2.2
136	
137	3.1
138	3.1
139	3.1
140	3.1
141	3.1
142	3.1
143	3.1
144	3.1
145	3.1
146	3.1
147	0
148	3.1
149	3.1
150	3.1
151	3.1
152	3.1
153	3.1
154	3.1
155	3.1
156	3.1
157	3.1
158	3.1
159	2.2
160	1.5
161	3.1
162	
163	0

MODE PIN NO.	LEVEL(V)
164	3.1
165	3.1
166	3.1
167	3.1
168	3.1
169	3.1
170	3.1
171	0
172	3.1
173	3.1
174	3.1
175	1.5
176	3.1
177	0
178	3.1
179	3.1
180	3.1
181	3.1
182	3.18
183	0.086
184	3
185	2.4
186	2.3
187	0
188	0
189	3.1
190	0
191	0.017
192	2.2
193	3.1
194	3.1
195	0
196	3.18
197	1.3
198	3.1
199	3.1
200	3.1
201	0
202	2.3
203	3.1
204	0.001
205	3.1
206	3.1
207	3.1
208	1.6
209	3.1
210	3.18
211	0.018
212	2.2
213	3.19
214	2.69
215	1.5
216	2.9
217	2.59
218	0

MODE PIN NO.	LEVEL(V)
219	2.29
220	2.08
221	2.29
222	2.29
223	2.49
224	3.1
225	2.39
226	2.45
227	1.5
228	0
229	1.52
230	0
231	1.61
232	1.6
233	3.1
234	1.6
235	1.6
236	1.5
237	0
238	1.6
239	1.4
240	1.5

MODE PIN NO.	LEVEL(V)
MEMORY IC301	
1	4.3
2	
3	3.1
4	0
5	3.2
6	2
7	
8	3.1
9	0.01
10	3.1
11	3.2
12	3.2
13	3.2
14	3.2
15	0
16	3.1
17	3.1
18	3.1
19	
20	0
21	0
22	0
23	3
24	
25	0.625
26	3.2
27	0.705
28	3.2
29	3.1
30	
31	0
32	
33	
34	
35	3.1
36	3.1
37	2.39
38	3.2
39	1.49
40	1.5
41	3.09
42	1.69
43	0
44	3.1
45	
46	3.1
47	
48	2.5
49	3.1
50	3.1
51	3.2
52	3.1
53	3.1

MODE PIN NO.	LEVEL(V)
54	3.1
55	3.1
56	3.1
57	3.1
58	3.1
59	3.1
60	3.1
61	0.5
62	0
63	3.1
64	3.1
65	3.1
66	3.1
67	3.1
68	1.6
69	0
70	0
71	3.1
72	0
73	
74	3.1
75	0
76	3.2
77	0
78	3.1
79	0.3
80	
81	0
82	0
83	2.5
84	0
85	3.19
86	3.19
87	4.4
88	3.19
89	4.4
90	0
91	4.4
92	0
93	0
94	0
95	0
96	0
97	3.17
98	3.17
99	3.1
100	0

MODE PIN NO.	EE	PLAY
DSP IC201 SP3301		
1	2.00	1.30
2	2.00	1.30
3	2.00	1.30
4	2.00	1.30
5	2.00	1.30
6	2.00	1.30
7	2.00	1.30
8	2.00	1.30
9	2.00	1.30
10	2.00	1.30
11	2.00	1.30
12	2.00	1.30
13	2.00	1.30
14	2.00	1.30
15	2.00	1.30
16	2.00	1.30
17	0.00	0.00
18	0.00	1.50
19	0.00	1.50
20	0.00	1.50
21	0.00	1.50
22	3.10	3.00
23	0.00	1.50
24	0.00	1.50
25	0.00	1.50
26	0.00	1.50
27	0.00	1.50
28	2.10	1.50
29	0.00	0.00
30	2.10	2.00
31	3.10	3.00
32	3.10	1.50
33	3.10	2.50
34	3.10	2.50
35	2.10	1.30
36	1.10	1.80
37	0.00	0.00
38	0.00	0.00
39	0.00	0.00
40	3.10	3.00
41	0.00	0.00
42	3.10	3.00
43	0.00	0.00
44	0.00	0.00
45	3.10	3.00
46	0.00	0.00
47	0.00	0.00
48	0.00	0.00
49	0.00	3.00
50	0.00	0.00
51	0.00	0.00
52	3.10	1.80
53	0.00	0.00

MODE PIN NO.	EE	PLAY
54	3.10	3.00
55	3.10	3.00
56	0.00	0.00
57	0.00	3.13
58	5.00	4.98
59	0.00	0.00
60	0.00	0.00
61	5.00	4.98
62	0.00	0.00
63	2.10	2.10
64	0.00	0.00
65	3.10	3.00
66	0.00	0.00
67	3.10	3.12
68	0.00	0.00
69	0.00	0.20
70	0.00	0.00
71	3.10	3.10
72	0.00	0.20
73	0.00	0.00
74	3.10	3.10
75	0.00	0.00
76	0.00	0.00
77	0.00	0.00
78	0.00	2.30
79	3.10	3.10
80	5.00	5.00
81	0.00	0.00
82	5.00	5.00
83	2.10	2.00
84	2.10	2.10
85	3.10	3.10
86	1.40	1.40
87	0.00	0.00
88	2.10	2.00
89	2.10	2.00
90	0.00	0.00
91	1.50	1.55
92	3.10	3.12
93	1.60	1.55
94	1.10	1.11
95	2.00	2.00
96	1.55	1.55
97	0.00	0.00
98	1.55	1.55
99	1.56	2.15
100	3.10	3.10
101	1.55	1.58
102	1.55	1.55
103	1.62	1.64
104	1.55	1.55
105	1.50	1.50
106	0.00	0.00
107	0.00	0.00
108	0.00	0.00

MODE PIN NO.	EE	PLAY
109	0.00	0.00
110	0.00	0.00
111	0.00	0.00
112	0.00	0.00
113	3.40	4.70
114	5.00	5.00
115	1.50	1.50
116	1.50	1.53
117	3.10	3.10
118	0.00	0.00
119	0.00	0.00
120	3.50	4.20
121	3.25	4.20
122	3.45	4.30
123	3.50	4.30
124	3.50	4.30
125	3.50	4.50
126	0.00	0.00
127	3.60	2.60
128	0.00	0.00
129	3.60	2.60
130	0.00	0.20
131	0.00	0.00
132	0.00	3.10
133	3.10	3.10
134	0.00	0.00
135	0.00	0.00
136	3.10	2.20
137	0.00	0.00
138	0.00	0.00
139	3.10	3.10
140	3.00	3.10
141	0.00	0.00
142	3.00	3.00
143	3.10	3.10
144	3.10	3.10
145	3.10	0.90
146	3.50	4.50
147	0.00	0.00
148	0.00	0.00
149	0.00	0.00
150	0.00	0.00
151	0.00	0.00
152	0.00	0.00
153	0.00	0.00
154	0.00	0.00
155	1.55	1.55
156	3.10	3.10
1		

13. PRINTED CIRCUIT DIAGRAM

1. MAIN P.C.BOARD

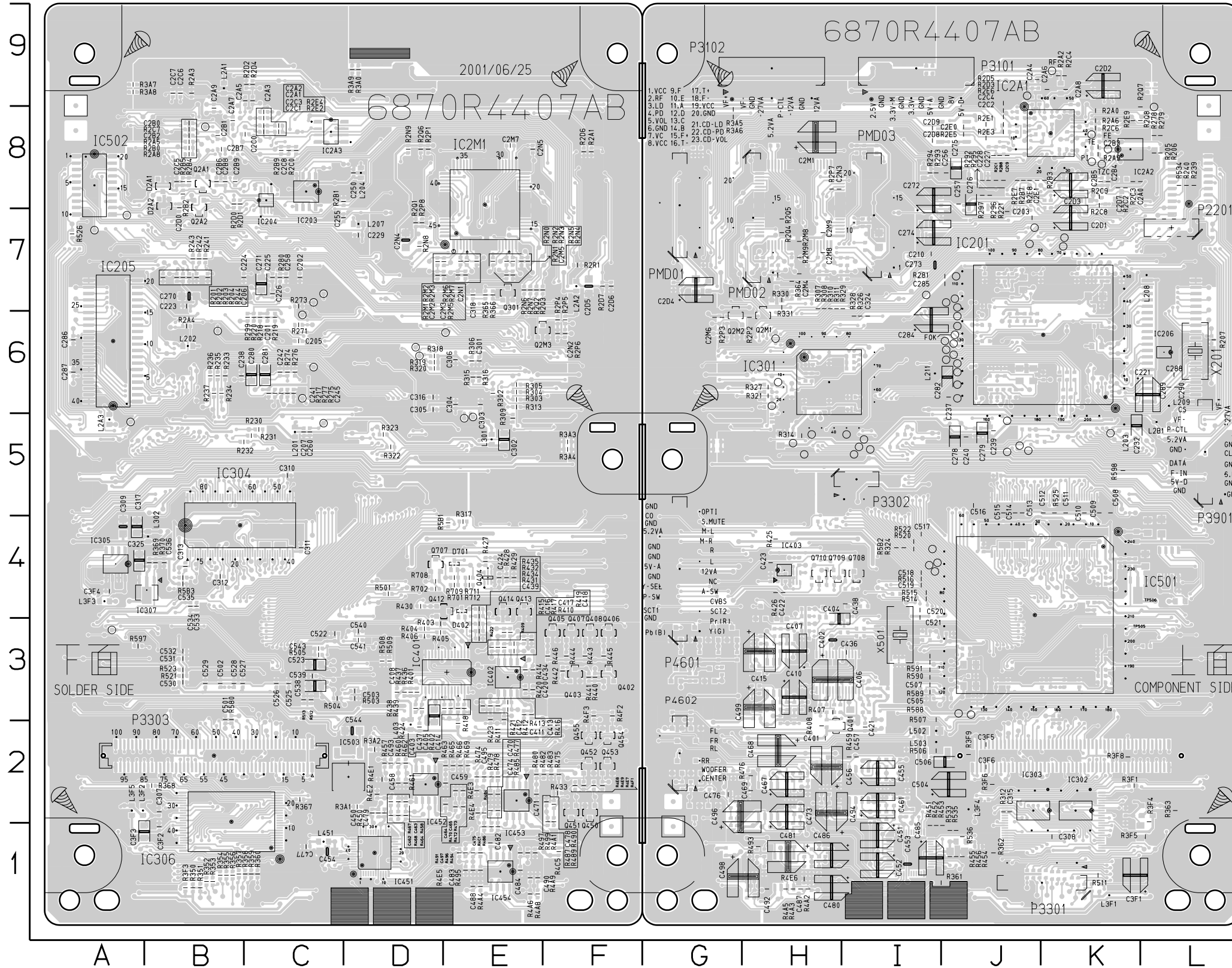

LOCATION GUIDE

(BOTTOM SIDE)

C201	C6	C301	E6	C497	E1	L451	C1	R2A8	B8	R320	D8	R433	F2	R4C1	E1
C202	C7	C302	E5	C501	B3	P3303	B2	R2B0	B8	R322	D5	R434	E3	R4C5	F1
C205	C6	C303	E6	C502	B3	Q2A1	B8	R2B1	D8	R323	D5	R435	E4	R4C5	F1
C206	B7	C304	E6	C503	D3	Q2A2	B8	R2B2	B8	R350	B1	R436	D3	R4E2	D2
C207	C5	C305	D6	C522	C3	Q2A3	F6	R2B4	B8	R351	B1	R437	D3	R4E3	E2
C223	B7	C306	E6	C523	C3	Q301	F7	R2B5	B8	R352	B1	R438	D4	R4E4	E2
C224	C7	C307	B2	C525	C3	Q402	F3	R2B9	B8	R353	B1	R439	D3	R4E5	F1
C225	C7	C309	A4	C526	C3	Q403	F3	R2C0	B8	R354	B1	R440	F3	R4E7	F2
C226	C7	C303	C5	C527	E3	Q204	E4	R2C7	B8	R355	B1	R441	F3	R4E8	F2
C229	D7	C311	C4	C528	B3	Q405	F3	R2D0	B8	R356	B1	R442	F3	R4E9	F2
C238	B6	C312	B4	C529	B3	Q406	F3	R2D1	B8	R357	B1	R443	F3	R4F1	F2
C241	C6	C313	B4	C530	B3	Q407	F3	R2D2	C8	R358	C1	R444	F3	R4F2	F2
C242	C6	C316	D6	C531	B3	Q408	F3	R2D4	C9	R359	C1	R445	F3	R4F3	F3
C245	C6	C317	A4	C532	B3	Q412	E4	R2D6	F8	R360	C1	R446	F3	R501	D4
C250	D8	C318	E7	C533	B4	Q413	E4	R2D7	F7	R365	E7	R450	D2	R503	D3
C255	D7	C3F2	B1	C534	B4	Q414	E4	R2E2	C8	R366	E7	R457	D2	R504	C3
C258	C7	C3F3	B1	C535	B4	Q450	F2	R2E4	C8	R367	C2	R458	D2	R505	C3
C260	C5	C3F4	A4	C536	B4	Q451	F2	R2M1	D7	R368	D2	R460	D2	R508	D3
C270	B7	C403	D3	C538	C3	Q452	F2	R2M2	D7	R3A0	D9	R461	D2	R509	D3
C271	C7	C405	E3	C539	C3	Q453	F2	R2M3	E7	R3A1	D2	R462	D2	R512	C3
C272	C8	C402	D3	C540	D3	Q454	F2	R2M4	E7	R3A8	A9	R467	D2	R508	B3
C281	C5	C411	E3	C541	D3	Q455	F2	R2M6	E7	R3A3	F3	R464	D2	R513	C3
C286	A6	C412	E3	C543	C3	Q707	D4	R2M7	E7	R3A4	F5	R465	E2	R523	B3
C287	A6	C413	E3	D2A1	B8	R201	B7	R2N0	E7	R3A7	A9	R466	E2	R526	A7
C288	C8	C416	E3	D2A2	B8	R202	B7	R2N1	E7	R3A8	A9	R467	D2	R508	B3
C2A3	C9	C417	E3	D701	E4	R204	B7	R2N3	E7	R3F3	B1	R469	E2	R581	E4
C2A5	C9	C418	E3	IC203	C8	R217	C6	R2N4	E7	R401	D3	R470	E2	R583	B4
C2A7	B8	C420	E3	IC204	C8	R218	C6	R2N5	E7	R402	D3	R472	E2	R701	E4
C2A9	B8	C424	E3	IC205	C8	R219	C6	R2N6	E7	R403	D3	R473	E2	R702	D4
C2B0	B8	C434	E3	IC2A3	C8	R220	C6	R2N7	E7	R404	D3	R474	E2	R708	D4
C2B1	B8	C437	E3	IC2M1	E8	R230	C5	R2N8	D7	R405	D3	R475	E2	R709	E4
C2B2	B8	C439	E3	IC304	B4	R231	C5	R2N9	D8	R406	D3	R477	E2	R711	E4
C2B3	B8	C440	E3	IC305	B4	R232	C5	R2N0	D8	R407	D3	R478	E2	R712	E4
C2B8	B8	C454	C1	IC306	B2	R233	B6	R2P4	F8	R410	D3	R479	E2	TP206	A3
C2B9	B8	C458	D2	IC401	E3	R234	B6	R2P5	F6	R411	E3	R480	E2	TP207	C6
C2B9	B8	C459	E2	IC402	E3	R235	B6	R2P6	F6	R412	E3	R482	F2	TP208	C6
C2C1	C8	C463	D2	IC452	D2	R237	B6	R201	D7	R414	E3	R484	E2	TP218	B6
C2C3	C8	C464	E2	IC453	E2	R241	B7	R202	E7	R415	E3	R485	E2	TP221	C6
C2C5	B8	C465	E2	IC454	E1	R242	B7	R203	F7	R416	E3	R486	E1	TP231	C6
C2C7	B8	C470	E2	IC502	B2	R243	B7	R206	D8	R417	E3	R487	F2	TP235	A5
C2C8	C8	C474	E2	L202	B6	R271	C6	R302	E6	R419	E3	R490	F2	TP244	C7
C2D0	B8	C475	E1	L204	D8	R273	C7	R303	E6	R420	E3	R491	E1	TP2A1	B8
C2D1	C8	C477	E1	L207	F7	R274	C7	R304	E6	R421	E3	R492	F2	TP2A2	B8
C2D6	F7	C478	F2	L2A1	B9	R275	C6	R305	E6	R422	E3	R495	E1	TP360	D6
C2M2	F7	C479	D2	L2A2	F7	R276	C6	R306	E6	R423	E3	R496	E1	TP361	D6
C2M3	F7	C482	E1	L2A3	A5	R277	C6	R309	E5	R424	D2	R497	E1	TP362	E5
C2M4	F7	C483	E1	L2A4	A5	R278	C6	R312	E5	R427	D2	R499	E1	TP363	E5
C2M1	F7	C488	E1	L3F2	A2	R2A1	F8	R316	E6	R429	E4	R4A4	E1	TP516	A7
C2M2	F7	C490	E1	L3F3	A4	R2A3	B9	R317	E4	R430	D4	R4A6	E1		
C2M4	D7	C493	D2	L403	A2	R2A4	B6	R318	D6	R431	E3	R4A8	E1		
C2M5	D7	C495	E2	L403	D2	R2A5	B8	R319	D6	R432	E3	R4A9	E1		

(TOP SIDE)

C203	J7	C410	H3	L3F1	K1	R2P2	H6	R533	J1	TP319	K2
C210	I7	C415	H3	L3F4	J2	R2P3	G6	R534	L8	TP320	K2
C221	L6	C421	I2	L502	I2	R2P7	H8	R535	J1	TP321	J1
C227	J6	C422	H4	L503	I2	R2P6	H8	R536	J1	TP322	J1
C228	B8	C423	H4	P2201	L7	R205	H7	R588	I3	TP323	J1
C232	K5	C436	I3	P3101	I9	R207	L8	R589	I3	TP324	J1
C237	J6	C438	I4	P3102	H9	R208	L8	R590	I3	TP325	J1
C238	J6	C439	I4	P3103	H9	R209	L8	R591	I3	TP326	J1
C240	J5	C452	I1	P3302	I5	R308	H7	R582	I4	TP327	J1
C256	J8	C453	I1	P3901	L5	R310	H7	TP201	K5	TP328	K1
C257	J8	C455	I2	P4601	G4	R311	H7	TP202	J5	TP329	K1
C272	B8	C456	H2	P4602	G2	R312	J2	TP203	J5	TP330	K1
C273	I7	C457	H2	TP204	J5	TP331	J5	TP331	J5	TP331	J5
C274	I7	C461	I2	PMD02	H7	R321	H6	TP205	J5	TP332	J1
C275	J8	C467	H2	PMD03	I7	R324	I4	TP209	J6	TP333	J1
C276	J8	C468	H2	Q2M1	H5	R325	L4	TP210	J6	TP334	J1
C278	J5	C469	H2	Q2M2	G8	R326	L4	TP211	J6	TP335	J2
C279	J5	C473	H2	Q401	H2	R327	H6	TP212	J6	TP336	J2
C282	J6	C476	G2	Q708	I4	R328	I6	TP214	J6	TP337	K1
C284	I6	C480	H1	Q709	H4	R329	I7	TP215	J6	TP338	K1
C285	I7	C481	H1	Q710	H4	R330	H7	TP216	J6	TP339	K2
C288	L6	C485	I1	R205	L8	R331	H7	TP219	H6	TP340	K2
C289	L6	C486	H1	R206	L8	R332	L4	TP220	J6	TP341	K2
C290	L6	C487	H1	R207	L6	R361	J1	TP222	K7	TP342	K2
C290	L6	C488	H1	R207	L6	R361	J1	TP222	K7	TP342	K2
C290	L6	C489	H1	R207	L6	R361	J1	TP222	K7	TP342	K2
C2A4	J9	C494	H2	R239	L8	R363	L2	TP224	K8	TP344	K2
C2A6	K9	C496	G2	R240	L8	R364	H7	TP225	J6	TP345	L2
C2A8	K9	C498	H1	R278	L8	R3A5	G8	TP226	J6	TP346	J2
C2B3	K8	C499	H3	R279	L8	R3A6	G8	TP228	J6	TP349	I5
C2B4	K8	C504	I2	R281	J7	R3F1	K2	TP229	J7	TP350	I5
C2B5	K8	C505	I3	R292	J8	R3F4	L2	TP230	J7	TP351	I5
C2C2	J8	C506	J2	R293	I8	R3P5	L1	TP232	J7	TP352	I5
C2C4	J8	C507	I3	R294	I8	R3P6	J2	TP233	J7	TP353	H6
C2C9	H8	C508	K5	R395	B3	R3F8	K2	TP234	J7	TP354	I5
C2D1	K7	C509	K5	R296	J8	R3F9	J2	TP239	J7	TP355	H6
C2D2	K9	C510	K5	R297	J8	R407	H3	TP241	J6	TP356	H6
C2D3	K8	C511	K5	R2A0	K8	R408	H2	TP242	J7	TP357	H6
C2D4	K8	C512	K5	R2A2	K8	R425	H1	TP245	I7	TP358	H6
C2D7	K8	C513	J5	R2A6	K8	R426	H4	TP242	L8	TP363	K1
C2D8	I8	C514	J5	R2A9	K8	R451	I1	TP2A3	K8	TP3A1	K2
C2D9	I8	C515	J5	R2B3	K8	R452	I1	TP2A4	K8	TP3A2	L2
C2E1	H8	C516	I4	R2B8	J8	R453	H1	TP2A5	K8	TP3A3	L2
C2E1	H8	C517	I4	R2B8	J8	R454	J1	TP2A8	K9	TP3A4	L2
C2M1	H8	C518	I4	R2C1	J8	R455	J1	TP301	L1	TP3A5	L2
C2M4	H7	C519	I4	R2C2	K8	R456	J1	TP302	K2	TP3A6	L2
C2M5	H7	C520	I4	R2C3	K8	R459	I2	TP303	K2	TP3A7	L2
C2M6	H7	C521	I3	R2C4	K9	R476	H2	TP304	K1	TP501	I4
C2M9	H7	IC201	K6	R2C6	K8	R493	H1	TP305	K2	TP502	I4
C2M3	H8	IC206	L6	R2C8	K8	R4A2	H1	TP306	K1	TP503	I4
C301	I1	IC303	J2	R2C9	K8	R4A3	H1	TP307	K2	TP504	I4
C315	J2	IC2A2	K8	R2D3	J8	R4A5	H1	TP308	K1	TP505	L3
C319	L4	IC301	H6	R2D5	J9	R4E6	H1	TP309	K2	TP506	L4
C324	I6	IC302	K2	R2E1	J8	R506	I2	TP310	K1	TP513	J3
C402	H3	L208	L7	R2E8	J8	R516	I4	TP312	K2	TP514	J3
C3F5	J2	IC403	H4	R2E5	J8	R511	K1	TP312	K2	TP517	J2
C3F6	J2	IC501	J4	R2E6	J8	R514	I4	TP313	K2	X201	L6
C401	H2	L203	K5	R2E7	J8	R515	I4	TP314	K2	X501	L3
C402	H3	L208	L7	R2E8	J8	R516	I4	TP315	K2		
C404	H3	L209	L6	R2E9	K8	R520	I4	TP316	K2		
C406	H3	L211	I6	R2M8	H7	R522	I4	TP317	K2		
C407	H3	L2B1	L5	R2M9	H7	R525	K5	TP318	K2		

14. ELECTRICAL PARTS LIST

ASSIGNMENT OF COMMON PARTS CODES.

RESISTORS

R***: 1) GD05 × × × 140, Carbon film fixed resistor, ±5% 1/4W
 R***: 2) GD05 × × × 160, Carbon film fixed resistor, ±5% 1/6W

① Resistance value

Examples ;

① Resistance value
 0.1 Ω 001 10 Ω 100 1 kΩ 102 100 kΩ 104
 0.5 Ω 005 18 Ω 180 2.7 kΩ 272 680 kΩ 684
 1 Ω 010 100 Ω 101 10 kΩ 103 1 MΩ 105
 6.8 Ω 068 390 Ω 391 22 kΩ 223 4.7 MΩ 475

Note : Please distinguish 1/4W from 1/6W by the shape of parts used actually.

CAPACITORS

C***: CERAMIC CAP.

3) DD1 × × × × 370, Ceramic capacitor
 Disc type
 Temp.coef.P350 ~N1000, 50V
 ② Capacity value
 ③ Tolerance

Examples ;

② Tolerance (Capacity deviation)
 ±0.25 pF 0
 ±0.5 pF 1
 ±5% 5

* Tolerance of COMMON PARTS handled here are as follows :

0.5 pF ~ 5 pF ±0.25 pF
 6 pF ~ 10 pF ±0.5 pF
 12 pF ~ 560 pF ±5%

③ Capacity value

0.5 pF 005 3 pF 030 100 pF 101
 1 pF 010 10 pF 100 220 pF 221
 1.5 pF 015 47 pF 470 560 pF 561

C***: CERAMIC CAP.

4) DK16 × × × × 300, High dielectric constant ceramic capacitor
 Disc type
 Temp.chara. 2B4, 50V
 ④ Capacity value

Examples ;

④ Capacity value
 100 pF 101 1000 pF 102 10000 pF 103
 470 pF 471 2200 pF 222

C***: 5) ELECTROLY CAP. (E), 6) FILM CAP. (F)

5) EA × × × × × × 10, Electrolytic capacitor
 One-way lead type, Tolerance ±20%
 ⑤ Working voltage
 ⑥ Capacity value

Examples ;

⑤ Capacity value
 0.1 μF 104 4.7 μF 475 100 μF 107
 0.33 μF 334 10 μF 106 330 μF 337
 1 μF 105 22 μF 226 1100 μF 118
 2200 μF 228

⑥ Working voltage

6.3V 006 25V 025
 10V 010 35V 035
 16V 016 50V 050

6) DF15 × × × × 350 → Plastic film capacitor
 DF15 × × × × 310 → One-way type, Mylar ±5% 50V
 DF16 × × × × 310 → Plastic film capacitor
 One-way type, Mylar ±10% 50V
 ⑦ Capacity value

Examples ;

⑦ Capacity value
 0.001 μF (1000 pF) 102 0.1 μF 104
 0.0018 μF 182 0.56 μF 564
 0.01 μF 103 1 μF 105
 0.015 μF 153

NOTE : 1) The above CODES (R***, R***, C***, C*** and C***) are omitted on the schematic diagram in some case.

2) On the occasion, be confirmed the common parts on the parts list.

3) Refer to "Common Parts List" for the other common parts (R105, DD4, DK4).

NOTE ON SAFETY FOR FUSIBLE RESISTOR :

The suppliers and their type numbers of fusible resistors are as follows;

1. KOA Corporation

Part No. (MJL) Type No. (KOA) Description
 NH05 × × × 140 → RF25S × × × × ΩJ (±5% 1/4W)
 NH05 × × × 120 → RF50S × × × × ΩJ (±5% 1/2W)
 NH85 × × × 110 → RF73B2A × × × × ΩJ (±5% 1/10W)
 NH95 × × × 140 → RF73B2E × × × × ΩJ (±5% 1/4W)

* Resistance value Resistance value
 (0.1 Ω - 10 kΩ)

2. Matsushita Electronic Components Co., Ltd

Part No. (MJL) Type No. (MEC) Description
 NF05 × × × 140 → ERD-2FCJ × × × (±5% 1/4W)
 RF05 × × × 140 → ERD-2FCG × × × (±2% 1/4W)
 NF02 × × × 140 → ERD-2FCG × × × (±2% 1/4W)
 RF02 × × × 140 → ERD-2FCG × × × (±2% 1/4W)

* Resistance value * Resistance value

Examples ;

* Resistance value
 0.1 Ω 001 10 Ω 100 1 kΩ 102 100 kΩ 104
 0.5 Ω 005 18 Ω 180 2.7 kΩ 272 680 kΩ 684
 1 Ω 010 100 Ω 101 10 kΩ 103 1 MΩ 105
 6.8 Ω 068 390 Ω 391 22 kΩ 223 4.7 MΩ 475

ABBREVIATION AND MARKS

ANT. : ANTENNA	BATT. : BATTERY
CAP. : CAPACITOR	CER. : CERAMIC
CONN. : CONNECTING	DIG. : DIGITAL
HP. : HEADPHONE	MIC. : MICROPHONE
μ-PRO : MICROPROCESSOR	REC. : RECORDING
RES. : RESISTOR	SPK. : SPEAKER
SW. : SWITCH	TRANSF. : TRANSFORMER
TRIM. : TRIMMING	TRS. : TRANSISTOR
VAR. : VARIABLE	X'TAL : CRYSTAL

NOTE ON FUSE :

Regarding to all parts of parts code **FS20xxx2xx**, replace only with Wickmann-Werke GmbH, Type 372 non glass type fuse.

NOTE ON SAFETY :

Symbol \blacktriangle Fire or electrical shock hazard. Only original parts should be used to replaced any part marked with symbol \blacktriangle . Any other component substitution (other than original type), may increase risk of fire or electrical shock hazard.

安全上の注意 :

\blacktriangle がついている部品は、安全上重要な部品です。必ず指定されている部品番号の部品を使用して下さい。

POS. NO	VERS. COLOR	DESCRIPTION	PART NO. (MJL)	POS. NO	VERS. COLOR	DESCRIPTION	PART NO. (MJL)	
CAPACITORS				C288		0CH1104K942	CHIP CER. 0.1μF 50V Z	nsp
C101		624-088F	DRAWING PCX2 275V 0.1μF M	C2A0		0CH1104K942	CHIP CER. 0.1μF 50V Z	nsp
C102		624-088F	DRAWING PCX2 275V 0.1μF M	C2A1		0CH1104K942	CHIP CER. 0.1μF 50V Z	nsp
C103		0CE157CR610	ELECT 150μF 250V M	C2A2		0CH1222K562	CHIP CER. 2200pF 50V K	nsp
C104		624-085D	ELECT 47μF 50V (SMPS)	C2A3				
C109		0CE108BF638	ELECT 1000μF 16V M			0CH1104K942	CHIP CER. 0.1μF 50V Z	nsp
C110		0CN4730K948	TUBULAR	C2A9				
			0.047μF 50V +80% -20%	C2B0		0CH1104K942	CHIP CER. 0.1μF 50V Z	nsp
C112		0CE3376D638	ELECT 330μF 10V M	C2B1		0CH1104K942	CHIP CER. 0.1μF 50V Z	nsp
C113		0CG3320U630	CER. 3300pF 400V M (NK A S)	C2B2		0CH1104K942	CHIP CER. 0.1μF 50V Z	nsp
C115		0CE1064K638	ELECT 10μF 50V M	C2B3		0CH1473H942	CHIP CER. 0.047μF 25V Z	nsp
C116		0CE477BH638	ELECT 470μF 25V M	C2B4		0CH4561K512	CHIP CER. 560pF 50V K	nsp
C117		0CN4730K948	TUBULAR	C2B5		0CH4561K512	CHIP CER. 560pF 50V K	nsp
			0.047μF 50V +80% -20%	C2B6		0CH1333K562	CHIP CER. 0.033μF 50V K	nsp
C118		0CE1076F638	ELECT 100μF 16V M	C2B7		0CH1333K562	CHIP CER. 0.033μF 50V K	nsp
C119		624-087B	HIGH-VOL 100pF 1KV	C2B8		0CH1104K942	CHIP CER. 0.1μF 50V Z	nsp
C120		0CE1076F638	ELECT 100μF 16V M	C2B9		0CH1104K942	CHIP CER. 0.1μF 50V Z	nsp
C121		0CE2276F638	ELECT 220μF 16V M	C2C0		0CH4221K412	CHIP CER. 220pF 50V J	nsp
C122		624-085D	ELECT 47μF 50V (SMPS)	C2C1				
C123		0CE108BF638	ELECT 1000μF 16V M			0CH1222K562	CHIP CER. 2200pF 50V K	nsp
C124		0CE337CH618	ELECT 330μF 25V M	C2C4				
C126		0CQ1031Y519	MYLAR 0.01μF 630V K	C2C5		0CH1104K942	CHIP CER. 0.1μF 50V Z	nsp
C127		0CE2274C638	ELECT 220μF 6.3V M	C2C8		0CH4330K412	CHIP CER. 33pF 50V J	nsp
C128		0CQ4732K409	MYLAR 0.047μF 50V J	C2C9		0CH4330K412	CHIP CER. 33pF 50V J	nsp
C130		0CE1076F638	ELECT 100μF 16V M	C2D0		0CH1104K942	CHIP CER. 0.1μF 50V Z	nsp
C131		0CE1076F638	ELECT 100μF 16V M	C2D1				
C137		0CE3376D638	ELECT 330μF 10V M			0CH8476C611	CHIP ELECT 47μF 6.3V M	EY47600620
C138		0CE1076F638	ELECT 100μF 16V M	C2D4				
				C2D5		0CH1225F944	CER. 2.2μF 16V +80% -20%	nsp
C201		0CH1104K942	CHIP CER. 0.1μF 50V Z	C2D6		0CH1104K942	CHIP CER. 0.1μF 50V Z	nsp
C202		0CH1104K942	CHIP CER. 0.1μF 50V Z	C2D7		0CH1104K942	CHIP CER. 0.1μF 50V Z	nsp
C203		0CH1104K942	CHIP CER. 0.1μF 50V Z	C2D9		0CH1104K942	CHIP CER. 0.1μF 50V Z	nsp
C205		0CH1104K942	CHIP CER. 0.1μF 50V Z	C2E1		0CH1182K562	CHIP CER. 1800pF 50V K	nsp
C206		0CH1104K942	CHIP CER. 0.1μF 50V Z					
C207		0CH1104K942	CHIP CER. 0.1μF 50V Z	C2M1		0CH8107F611	CHIP ELECT 100μF 16V M	EY10701660
C210		0CH1104K942	CHIP CER. 0.1μF 50V Z	C2M2		0CH1682K562	CHIP CER. 6800pF 50V K	nsp
C221		0CH8476C611	CHIP ELECT 47μF 6.3V M	C2M3		0CH1472K562	CHIP CER. 4700pF 50V K	nsp
C223		0CH1104K942	CHIP CER. 0.1μF 50V Z	C2M4				
C224		0CH1104K942	CHIP CER. 0.1μF 50V Z			0CH1104K942	CHIP CER. 0.1μF 50V Z	nsp
C226				C2M9				
				C2N1		0CH1104K942	CHIP CER. 0.1μF 50V Z	nsp
C229		0CH1104K942	CHIP CER. 0.1μF 50V Z	C2N2		0CH1103K562	CER. 0.01μF 50V K	nsp
C232		0CH7106C611	TANTAL 10μF 6.3V M	C2N3		0CH1223K942	CHIP CER. 0.022μF 50V Z	nsp
C237		0CH1104K942	CHIP CER. 0.1μF 50V Z	C2N4		0CH1225F944	CER. 2.2μF 16V +80% -20%	nsp
C238		0CH1104K942	CHIP CER. 0.1μF 50V Z	C2N5		0CH1104K942	CHIP CER. 0.1μF 50V Z	nsp
C239		0CH1104K942	CHIP CER. 0.1μF 50V Z					
C240		0CH1222K562	CHIP CER. 2200pF 50V K	C301		0CH1104K942	CHIP CER. 0.1μF 50V Z	nsp
C241		0CH1104K942	CHIP CER. 0.1μF 50V Z	C302		0CH7106C611	TANTAL 10μF 6.3V M	EY10600650
C242		0CH1104K942	CHIP CER. 0.1μF 50V Z	C303				
C245		0CH1104K942	CHIP CER. 0.1μF 50V Z			0CH1104K942	CHIP CER. 0.1μF 50V Z	nsp
C250		0CH1104K942	CHIP CER. 0.1μF 50V Z	C308				
C255				C309		0CH1225F944	CER. 2.2μF 16V +80% -20%	nsp
				C310				
C258		0CH1104K942	CHIP CER. 0.1μF 50V Z			0CH1104K942	CHIP CER. 0.1μF 50V Z	nsp
C260		0CH4100K112	CHIP CER. 10pF 50V	C313				
C270		0CH1225F944	CER. 2.2μF 16V +80% -20%	C315		0CH4560K412	CHIP CER. 56pF 50V J	nsp
C271		0CH7106C611	TANTAL 10μF 6.3V M	C316		0CH1104K942	CHIP CER. 0.1μF 50V Z	nsp
C272		0CH8476C611	CHIP ELECT 47μF 6.3V M	C317		0CH7106C611	TANTAL 10μF 6.3V M	EY10600650
C273		0CH1225F944	CER. 2.2μF 16V +80% -20%	C318		0CH1103K562	CER. 0.01μF 50V K	nsp
C274		0CH8476C611	CHIP ELECT 47μF 6.3V M	C324		0CH1104K942	CHIP CER. 0.1μF 50V Z	nsp
C275		0CH7106C611	TANTAL 10μF 6.3V M	C325		0CH7106C611	TANTAL 10μF 6.3V M	EY10600650
C276		0CH7106C611	TANTAL 10μF 6.3V M	C3F1		0CH8476C611	CHIP ELECT 47μF 6.3V M	EY47600620
C278				C3F2		0CH1104K942	CHIP CER. 0.1μF 50V Z	nsp
				C3F3		0CH7106C611	TANTAL 10μF 6.3V M	EY10600650
C282				C3F4		0CH1104K942	CHIP CER. 0.1μF 50V Z	nsp
C284		0CH8476C611	CHIP ELECT 47μF 6.3V M M	C3F5		0CH1104K942	CHIP CER. 0.1μF 50V Z	nsp
C285		0CH1104K942	CHIP CER. 0.1μF 50V Z	C3F6		0CH1104K942	CHIP CER. 0.1μF 50V Z	nsp
C286		0CH4220K412	CHIP CER. 22pF 50V J M					
C287		0CH4220K412	CHIP CER. 22pF 50V J					

NOTE : "nsp" PART IS LISTED FOR REFERENCE ONLY, MARANTZ WILL NOT SUPPLY THESE PARTS.

POS. NO	VERS. COLOR	DESCRIPTION	PART NO. (MJI)	POS. NO	VERS. COLOR	DESCRIPTION	PART NO. (MJI)
C401		0CH1104K942 CHIP CER. 0.1µF 50V Z	nsp	D108		0DD010009AC EU01W (R-FORM)	*HD201390R
C402		0CH1225F944 CER. 2.2µF 16V +80% -20%	nsp	D109		0DR158220AA 1N5822 BK O201A 40V	*HD201590R
C403		0CH7106C611 TANTAL 10µF 6.3V M	EY10600650	D110		0DD010009AC EU01W (R-FORM)	*HD201390R
C404		0CH7106C611 TANTAL 10µF 6.3V M	EY10600650	D116		874-000T WIRE	nsp
C406		0CH8477C611 CHIP ELECT 470µF 6.3V M	*EY000370R	D117		874-000T WIRE	nsp
C407		0CH8476C611 CHIP ELECT 47µF 6.3V M	EY47600620	D2A1		0DS202009CA DAN202K SOT23 80	HZ20002210
C408		0CH1104K942 CHIP CER. 0.1µF 50V Z	nsp	D2A2		0DS202009CA DAN202K SOT23 80	HZ20002210
C410		0CH8476C611 CHIP ELECT 47µF 6.3V M	EY47600620	D402		0DD120009EA CHIP KDS120(USM)	*HZ200170R
C411		0CH1102K512 CER. 1000pF 50V K	nsp	DIG901		6302R-V103B DIGITRON 7-BT-273GNYK	*HQ300520R
C412		0CH4561K512 CHIP CER. 560pF 50V K	nsp	ZD101		0DZ560009CA ZENER MTZ5.6B	*HD301830R
C413		0CH1104K942 CHIP CER. 0.1µF 50V Z	nsp	ZD605		0DZ562609AA ZENER GDZJ5.6B	*HD301840R
C414		0CH4680K412 CHIP CER. 68pF 50V J	nsp	ZD606		0DZ562609AA ZENER GDZJ5.6B	*HD301840R
C415		0CH8107F611 CHIP ELECT 100µF 16V M	EY10701660	ZD611		0DZ562609AA ZENER GDZJ5.6B	*HD301840R
C416		0CH1104K942 CHIP CER. 0.1µF 50V Z	nsp	ZD612		0DZ562609AA ZENER GDZJ5.6B	*HD301840R
C417		0CH1102K512 CER. 1000pF 50V K	nsp	ZD635		0DZ562609AA ZENER GDZJ5.6B	*HD301840R
C418		0CH1392K562 CHIP CER. 3900pF 50V K	nsp	}		0DZ562609AA ZENER GDZJ5.6B	*HD301840R
C420		0CH1392K562 CHIP CER. 3900pF 50V K	nsp	ZD638		0DZ562609AA ZENER GDZJ5.6B	*HD301840R
C421		0CH1104K942 CHIP CER. 0.1µF 50V Z	nsp	ZD641		0DZ562609AA ZENER GDZJ5.6B	*HD301840R
C423		0CH1104K942 CHIP CER. 0.1µF 50V Z	nsp	}		0DZ562609AA ZENER GDZJ5.6B	*HD301840R
C424		0CH1103K562 CER. 0.01µF 50V K	nsp	ZD644		0DZ560009CA ZENER MTZ5.6B	*HD301830R
C434		0CH4561K512 CHIP CER. 560pF 50V K	nsp	ZD901		0DZ560009CA ZENER MTZ5.6B	*HD301830R
C436		0CH1104K942 CHIP CER. 0.1µF 50V Z	nsp	ZD902			
C439							
C503		0CH1104K942 CHIP CER. 0.1µF 50V Z	nsp			INTEGRATED CIRCUITS	
C504		0CH8476C611 CHIP ELECT 47µF 6.3V M	EY47600620	IC101		0IPMGFA005A IC POWER KA5M0365R-YDTU	*HC107420R
C505		0CH1104K942 CHIP CER. 0.1µF 50V Z	nsp	IC102		657-063A SENSOR LTV-817B PHOTO COUPLER	*HC200090R
C506		0CH7106C611 TANTAL 10µF 6.3V M	EY10600650	IC103		0IKE781200B IC KIA7812PI 12V 1A KEC	*HC300390R
C507		0CH1104K942 CHIP CER. 0.1µF 50V Z	nsp	IC104		0ISS431000A IC KA431AZ (LM431AZ)	*HC105750R
C522				IC105		0ISS780800H IC KA78R08 4P TO-220F BK	*HC300250R
C523		0CH7106C611 TANTAL 10µF 6.3V M	EY10600650	IC106		0ISS783300A IC KA78R33TU TO220-4L BK 3.3V	*HC300260R
C525		0CH1104K942 CHIP CER. 0.1µF 50V Z	nsp	IC107		0ISS783300A IC KA78R33TU TO220-4L BK 3.3V	*HC300260R
C536				IC108		0ISS791200A IC KA7912 ST REGULATOR	*HC300400R
C538		0CH7106C611 TANTAL 10µF 6.3V M	EY10600650	IC201		0IHY258010C IC GDC25D801D 208 QFP BK	*HC107430R
C540		0CH4150K412 CHIP CER. 15pF 50V J	nsp	IC203		0IJR341400C IC NJM3414AM-TE1 3K/REEL.	HC10179090
C541		0CH4270K412 CHIP CER. 27pF 50V J	nsp	IC204		0ISTLKE009A IC KIC7W53FU KEC 8PIN SM8	*HC107440R
C543		0CH1104K942 CHIP CER. 0.1µF 50V Z	nsp	IC205		0IGL440164C IC GLT440L16-40J4 40P SOJ	*HC106620R
C544		0CH1225F944 CER. 2.2µF 16V +80% -20%	nsp	IC206		0ITO704000F IC TC7W04FU	HC10382050
C601		0CN3920F668 TUBULA 3900pF 16V M	nsp	IC2A1		0ITI333721A IC SSI33P3721(VECEP.2) 64	*HC105760R
C603		0CE4774C638 ELECT 470µF 6.3V M	nsp	IC2A2		0IJR341400C IC NJM3414AM-TE1 3K/REEL.	HC10179090
C606		0CN3920F668 TUBULA 3900pF 16V M	nsp	IC2M1		0IFA303100A IC KA3031 48P QFP BK 6CH MOTOR	*HC107450R
C613		0CE4774C638 ELECT 470µF 6.3V M	nsp	IC301		0IXL957210B IC XC9572XL-10TQ100C 100 QFP TRAY	*HC107460R
C614		0CE4774C638 ELECT 470µF 6.3V M	nsp	IC302		0ISTLFA004C IC 74LCX573MTCX FAIRCHILD 20P	*HC700420R
C615		0CE4774C638 ELECT 470µF 6.3V M	nsp	IC303		0ISTLFA004C IC 74LCX573MTCX FAIRCHILD 20P	*HC700420R
C901		0CN6810K518 TUBULA 680pF 50V K	nsp	IC304		0IHY576532A IC HY57V653220CTC-7 8 6P TSOP	*HC107470R
C902		0CE4763C638 ELECT 47µF 6.3V M	nsp	IC305		0IMMRCB001A IC CAT93C56S-TE13 X'TAL	nsp
C903		0CN1030F678 TUBULA 0.01µF 16V M	nsp	IC306		0IMMRAL005B IC AT49BV1614-11TC ATMEL 48P	nsp
C904		0CE1063F638 ELECT 10µF 16V M	nsp	IC401		0IBB171600A IC PCM1716E 28P SSOP TP DAC	*HC105580R
C905		0CE4763C638 ELECT 47µF 6.3V M	nsp	IC402		0IJR458000B IC NJM4580M 8 DMP8 TP OP AMP	*HC105660R
C906		0CX3300K408 TUBULA 33pF 50V J	nsp	IC403		0ITO704000F IC TC7W04FU	HC10382050
C907		0CX3300K408 TUBULA 33pF 50V J	nsp	IC501		0INS860100A IC NDV8601 240 VQFP BK MICOM+MPEG	*HC107560R
C909		0CE4763C638 ELECT 47µF 6.3V M	nsp	IC502		0IFA742440F IC MM74HCT244SJ 20P	*HC700430R
C910		0CN1030F678 TUBULA 0.01µF 16V M	nsp	IC503		0IPMGRH003A IC POWER BA18BC0FP-E2 RW 3P	*HC107570R
C911		0CN1030F678 TUBULA 0.01µF 16V M	nsp	IC901		0IMCRNE002C IC UPD780232GC-043-8BT NEC 80	*HC107500R
C912		0CN1040K948 TUBULA 0.1µF 50V +80% -20%	nsp				
C913		0CN1040K948 TUBULA 0.1µF 50V +80% -20%	nsp				
C914		0CN1030F678 TUBULA 0.01µF 16V M	nsp				
		DIODES					
BD101		0DD160000DA S1WBA60 (1A 600V)	*HD201400R				
D100		0DD221009AA ERA22-10 KFLB	*HD201480R				
D102		0DR158220AA 1N5822 BK DO201AD 40V	*HD201590R				
D103		0DR310000AA RU3YXLF-C1 100V 2	*HD201470R				
D104		0DD010009AC EU01W (R-FORM)	*HD201390R				
D106		0DR104009AB RL104R	*HD201430R				
D107		0DD010009AC EU01W (R-FORM)	*HD201390R				

NOTE : *nsp* PART IS LISTED FOR REFERENCE ONLY, MARANTZ WILL NOT SUPPLY THESE PARTS.

POS. NO	VERS. COLOR	DESCRIPTION	PART NO. (MJI)	POS. NO	VERS. COLOR	DESCRIPTION	PART NO. (MJI)
IC902		0IKE704200B IC KIA7042P 3P 4.2V RESET	*HC105670R	R280		ORH0000C622 METAL CHIP 0 Ω 1 / 16 W J	nsp
		TRANSISTORS		R281		ORH2201C622 METAL CHIP 2.2k Ω 1 / 16 W J	nsp
Q107		OTR127309AA KTA1273-TP-Y (KTA966A)	*HT100620R	R292		ORH1201C622 METAL CHIP 1.2k Ω 1 / 16 W J	nsp
Q108		OTR319809AC KTC3198-TP-BL (KTC1815)	*HT300720R	R293		ORH2001C622 METAL CHIP 2k Ω 1 / 16 W J	nsp
Q2A1		OTR103709BB CHIP 2SA1037K-Q	HX110371A0	R294		ORH1500C622 METAL CHIP 150 Ω 1 / 16 W J	nsp
Q2A2		OTR103709BB CHIP 2SA1037K-Q	HX110371A0	R295		ORH2001C622 METAL CHIP 2k Ω 1 / 16 W J	nsp
Q2M1		OTR103009AA CHIP KRC103S-T1(NC)22-22	*BA000870R	R296		ORH1500C622 METAL CHIP 150 Ω 1 / 16 W J	nsp
Q2M2		OTR103009AA CHIP KRC103S-T1(NC)22-22	*BA000870R	R297		ORH1201C622 METAL CHIP 1.2k Ω 1 / 16 W J	nsp
Q2M3		OTR103009AA CHIP KRC103S-T1(NC)22-22	*BA000870R	R2A0		ORH1002C622 METAL CHIP 10k Ω 1 / 16 W J	nsp
Q301		OTR103009AA CHIP KRC103S-T1(NC)22-22	*BA000870R	R2A1		ORH0912C622 METAL CHIP 91 Ω 1 / 16 W J	nsp
Q401		OTR150409AC CHIP KTA1504-GR-T1(ASG)	*HX100140R	R2A2		ORH1202C622 METAL CHIP 12k Ω 1 / 16 W J	nsp
Q402		OTR150409AC CHIP KTA1504-GR-T1(ASG)	*HX100140R	R2A4		ORH0000C622 METAL CHIP 0 Ω 1 / 16 W J	nsp
Q403		OTR387509AC CHIP KTC3875S-GR-T1(ALG)	*HT300740R	R2A5		ORH0000C622 METAL CHIP 0 Ω 1 / 16 W J	nsp
Q404		OTR100009BMM UMZ1N TL UM6 3K	BA30002210	R2A6		ORH1001C622 METAL CHIP 1k Ω 1 / 16 W J	nsp
Q405				R2A9		ORH0000C622 METAL CHIP 0 Ω 1 / 16 W J	nsp
}		OTR387509AC CHIP KTC3875S-GR-T1(ALG)	*HT300740R	R2B1		ORH1001C622 METAL CHIP 1k Ω 1 / 16 W J	nsp
Q408				R2B2		ORH0000C622 METAL CHIP 0 Ω 1 / 16 W J	nsp
Q412		OTR150409AC CHIP KTA1504-GR-T1(ASG)	*HX100140R	R2B3		ORH1001C622 METAL CHIP 1k Ω 1 / 16 W J	nsp
Q413		OTR387509AC CHIP KTC3875S-GR-T1(ALG)	*HT300740R	R2B4		ORH0182C622 METAL CHIP 18 Ω 1 / 16 W J	nsp
Q414		OTR387509AC CHIP KTC3875S-GR-T1(ALG)	*HT300740R	R2B5		ORH0182C622 METAL CHIP 18 Ω 1 / 16 W J	nsp
		RESISTORS		R2B7		ORH6801C622 METAL CHIP 6.8k Ω 1 / 16 W J	nsp
R100		ORD1504H632 1.5M Ω 1/2 W J	nsp	R2B8		ORH1503C622 METAL CHIP 150k Ω 1 / 16 W J	nsp
R101		614-007A CEMENT 2.7Ω 2W SMPS V	nsp	R2B9		ORH1503C622 METAL CHIP 150k Ω 1 / 16 W J	nsp
R102		ORD2203F608 220k Ω 1/6 W J	nsp	R2C0		ORH3902C622 METAL CHIP 39k Ω 1 / 16 W J	nsp
R103		ORS5602K619 METAL 56k Ω 2 W J	GA05563020	R2C1		ORH3902C622 METAL CHIP 39k Ω 1 / 16 W J	nsp
R104		ORD2203F608 220k Ω 1/6 W J	nsp	R2C2		ORH1001C622 METAL CHIP 1k Ω 1 / 16 W J	nsp
R111		ORD3300F608 330 Ω 1/6 W J	nsp	R2C3		ORH1001C622 METAL CHIP 1k Ω 1 / 16 W J	nsp
R112		ORD0391F608 3.9 Ω 1/6 W J	nsp	R2C4		ORH1000C622 METAL CHIP 100 Ω 1 / 16 W J	nsp
R114		ORD1003F608 100k Ω 1/6 W J	nsp	R2C6		ORH0000C622 METAL CHIP 0 Ω 1 / 16 W J	nsp
R120		ORD4702F608 47k Ω 1/6 W J	nsp	R2C7		ORH0000C622 METAL CHIP 0 Ω 1 / 16 W J	nsp
R121		ORD1201F608 1.2k Ω 1/6 W J	nsp	R2C8		ORH0182C622 METAL CHIP 18 Ω 1 / 16 W J	nsp
R122		ORD2200F608 220 Ω 1/6 W J	nsp	R2C9		ORH0182C622 METAL CHIP 18 Ω 1 / 16 W J	nsp
R123		ORD1002F608 10k Ω 1/6 W J	nsp	R20		ORH1001C622 METAL CHIP 1k Ω 1 / 16 W J	nsp
R124		ORD1800F608 180 Ω 1/6 W J	nsp	R21		ORH0000C622 METAL CHIP 0 Ω 1 / 16 W J	nsp
R125		ORD3901F608 3.9k Ω 1/6 W J	nsp	R24		ORH0000C622 METAL CHIP 0 Ω 1 / 16 W J	nsp
R126		ORD1001F608 1k Ω 1/6 W J	nsp	R25		ORH0000C622 METAL CHIP 0 Ω 1 / 16 W J	nsp
R127		ORN3601E408 METAL 3.6k Ω 1/8 W F	nsp	R26		ORH0912C622 METAL CHIP 91 Ω 1 / 16 W J	nsp
R128		ORN3301E408 METAL 3.3k Ω 1/8 W F	nsp	R27		ORH0471C622 METAL CHIP 4.7 Ω 1 / 16 W J	nsp
R130		ORD1002F608 10k Ω 1/6 W J	nsp	R2E6		ORH0000C622 METAL CHIP 0 Ω 1 / 16 W J	nsp
R140		ORD1002F608 10k Ω 1/6 W J	nsp	R2E7		ORH6801C622 METAL CHIP 6.8k Ω 1 / 16 W J	nsp
R141		ORD1002F608 10k Ω 1/6 W J	nsp	R2E8		ORH1802C622 METAL CHIP 18k Ω 1 / 16 W J	nsp
R145		ORD4700F608 470 Ω 1/6 W J	nsp	R2E9		ORH5601C622 METAL CHIP 5.6k Ω 1 / 16 W J	nsp
R201				R2M1		ORH1001C622 METAL CHIP 1k Ω 1 / 16 W J	nsp
}		ORH0000C622 METAL CHIP 0 Ω 1 / 16 W J	nsp	R2M2		ORH1002C622 METAL CHIP 10k Ω 1 / 16 W J	nsp
R204				R2M3		ORH7501C622 METAL CHIP 7.5k Ω 1 / 16 W J	nsp
R207		ORH1004C622 METAL CHIP 1M Ω 1 / 16 W J	nsp	R2M5		ORH1001C622 METAL CHIP 1k Ω 1 / 16 W J	nsp
R217		ORH1002C622 METAL CHIP 10 Ω 1 / 16 W J	nsp	R2M6		ORH1002C622 METAL CHIP 10k Ω 1 / 16 W J	nsp
R218		ORH4700C622 METAL CHIP 470 Ω 1 / 16 W J	nsp	R2M7		ORH5601C622 METAL CHIP 5.6k Ω 1 / 16 W J	nsp
R219		ORH1002C622 METAL CHIP 10k Ω 1 / 16 W J	nsp	R2M8		ORH1001C622 METAL CHIP 1k Ω 1 / 16 W J	nsp
R220		ORH1002C622 METAL CHIP 10k Ω 1 / 16 W J	nsp	R2M9		ORH1002C622 METAL CHIP 10k Ω 1 / 16 W J	nsp
R221		ORH1002C622 METAL CHIP 10k Ω 1 / 16 W J	nsp	R2N0		ORH1202C622 METAL CHIP 12k Ω 1 / 16 W J	nsp
R230				R2N1		ORH1001C622 METAL CHIP 1k Ω 1 / 16 W J	nsp
}		ORH1000C622 METAL CHIP 100 Ω 1 / 16 W J	nsp	R2N2		ORH5601C622 METAL CHIP 5.6k Ω 1 / 16 W J	nsp
R237				R2N3		ORH1002C622 METAL CHIP 10k Ω 1 / 16 W J	nsp
R239				R2N4		ORH1502C622 METAL CHIP 15k Ω 1 / 16 W J	nsp
}		ORH0000C622 METAL CHIP 0 Ω 1 / 16 W J	nsp	R2N5		ORH1202C622 METAL CHIP 12k Ω 1 / 16 W J	nsp
R243				R2N6		ORH1001C622 METAL CHIP 1k Ω 1 / 16 W J	nsp
R271		ORH0000C622 METAL CHIP 0 Ω 1 / 16 W J	nsp	R2N7		ORH1001C622 METAL CHIP 1k Ω 1 / 16 W J	nsp
R273		ORH0000C622 METAL CHIP 0 Ω 1 / 16 W J	nsp	R2N8		ORH1002C622 METAL CHIP 10k Ω 1 / 16 W J	nsp
R274		ORH6200C622 METAL CHIP 620 Ω 1 / 16 W J	nsp	R2N9		ORH1002C622 METAL CHIP 10k Ω 1 / 16 W J	nsp
R275		ORH9100C622 METAL CHIP 910 Ω 1 / 16 W J	nsp	R2P1		ORH1002C622 METAL CHIP 10k Ω 1 / 16 W J	nsp
R276		ORH9100C622 METAL CHIP 910 Ω 1 / 16 W J	nsp	R2P2		ORH1002C622 METAL CHIP 10k Ω 1 / 16 W J	nsp
R277		ORH1500C622 METAL CHIP 150 Ω 1 / 16 W J	nsp	R2P3		ORH1002C622 METAL CHIP 10k Ω 1 / 16 W J	nsp
R278		ORH0000C622 METAL CHIP 0 Ω 1 / 16 W J	nsp	R2P4		ORH1802C622 METAL CHIP 18k Ω 1 / 16 W J	nsp
R279		ORH0000C622 METAL CHIP 0 Ω 1 / 16 W J	nsp	R2P5		ORH1002C622 METAL CHIP 10k Ω 1 / 16 W J	nsp
				R2P6		ORH1001C622 METAL CHIP 1k Ω 1 / 16 W J	nsp

NOTE : *nsp* PART IS LISTED FOR REFERENCE ONLY, MARANTZ WILL NOT SUPPLY THESE PARTS.

POS. NO	VERS. COLOR	DESCRIPTION	PART NO. (MJI)	POS. NO	VERS. COLOR	DESCRIPTION	PART NO. (MJI)
R2P7		0RH2202C622 METAL CHIP 22k Ω 1 / 16 W J	nsp	R424		0RH0102C622 METAL CHIP 10 Ω 1 / 16 W J	nsp
R2P8		0RH1201C622 METAL CHIP 1.2k Ω 1 / 16 W J	nsp	R425		0RH3300C622 METAL CHIP 330 Ω 1 / 16 W J	nsp
R2Q1		0RH1002C622 METAL CHIP 10k Ω 1 / 16 W J	nsp	R426		0RH2200C622 METAL CHIP 220 Ω 1 / 16 W J	nsp
R2Q2		0RH1001C622 METAL CHIP 1k Ω 1 / 16 W J	nsp	R427		0RH3300C622 METAL CHIP 330 Ω 1 / 16 W J	nsp
R2Q3		0RH1001C622 METAL CHIP 1k Ω 1 / 16 W J	nsp	R428		0RH2200C622 METAL CHIP 220 Ω 1 / 16 W J	nsp
R2Q4		0RH1502C622 METAL CHIP 15k Ω 1 / 16 W J	nsp	R429		0RH0752C622 METAL CHIP 75 Ω 1 / 16 W J	nsp
R2Q5		0RH1202C622 METAL CHIP 12k Ω 1 / 16 W J	nsp	R430		0RH1001C622 METAL CHIP 1k Ω 1 / 16 W J	nsp
R2Q6		0RH1002C622 METAL CHIP 10k Ω 1 / 16 W J	nsp	R431		0RH1001C622 METAL CHIP 1k Ω 1 / 16 W J	nsp
R2Q7		0RH6801C622 METAL CHIP 6.8k Ω 1 / 16 W J	nsp	R432		0RH1001C622 METAL CHIP 1k Ω 1 / 16 W J	nsp
R2Q8		0RH3301C622 METAL CHIP 3.3k Ω 1 / 16 W J	nsp	R433		0RH0000C622 METAL CHIP 0 Ω 1 / 16 W J	nsp
R2R1		0RH1001C622 METAL CHIP 1k Ω 1 / 16 W J	nsp	R434		0RH1001C622 METAL CHIP 1k Ω 1 / 16 W J	nsp
R302				R435		0RH1001C622 METAL CHIP 1k Ω 1 / 16 W J	nsp
}		0RH4701C622 METAL CHIP 4.7k Ω 1 / 16 W J	nsp	R439		0RH0000C622 METAL CHIP 0 Ω 1 / 16 W J	nsp
R306				R440		0RH1002C622 METAL CHIP 10k Ω 1 / 16 W J	nsp
R307		0RH5600C622 METAL CHIP 560 Ω 1 / 16 W J	nsp	R441		0RH2201C622 METAL CHIP 2.2k Ω 1 / 16 W J	nsp
R308		0RH5600C622 METAL CHIP 560 Ω 1 / 16 W J	nsp	R442			
R309		0RH1002C622 METAL CHIP 10k Ω 1 / 16 W J	nsp	}		0RH1001C622 METAL CHIP 1k Ω 1 / 16 W J	nsp
R310		0RH5600C622 METAL CHIP 560 Ω 1 / 16 W J	nsp	R446			
R311		0RH5600C622 METAL CHIP 560 Ω 1 / 16 W J	nsp	R503		0RH1500C422 METAL CHIP 150 Ω 1 / 16 W F	nsp
R314		0RH4701C622 METAL CHIP 4.7k Ω 1 / 16 W J	nsp	R504		0RH1001C422 METAL CHIP 1k Ω 1 / 16 W F	nsp
R315		0RH1002C622 METAL CHIP 10k Ω 1 / 16 W J	nsp	R505		0RH0102C622 METAL CHIP 10 Ω 1 / 16 W J	nsp
R316		0RH1002C622 METAL CHIP 10k Ω 1 / 16 W J	nsp	R506			
R317		0RH3901C622 METAL CHIP 3.9k Ω 1 / 16 W J	nsp	}		0RH0000C622 METAL CHIP 0 Ω 1 / 16 W J	nsp
R321		0RH1001C622 METAL CHIP 1k Ω 1 / 16 W J	nsp	R509			
R323		0RH0000C622 METAL CHIP 0 Ω 1 / 16 W J	nsp	R511		0RH3301C622 METAL CHIP 3.3k Ω 1 / 16 W J	nsp
R326		0RH4701C622 METAL CHIP 4.7k Ω 1 / 16 W J	nsp	R512		0RH0000C622 METAL CHIP 0 Ω 1 / 16 W J	nsp
R327		0RH1002C622 METAL CHIP 10k Ω 1 / 16 W J	nsp	R513		0RH0000C622 METAL CHIP 0 Ω 1 / 16 W J	nsp
R328				R514		0RH0222C622 METAL CHIP 22 Ω 1 / 16 W J	nsp
}		0RH4701C622 METAL CHIP 4.7k Ω 1 / 16 W J	nsp	R515		0RH0222C622 METAL CHIP 22 Ω 1 / 16 W J	nsp
R331				R516		0RH3300C622 METAL CHIP 330 Ω 1 / 16 W J	nsp
R351				R520		0RH0222C622 METAL CHIP 22 Ω 1 / 16 W J	nsp
}		0RH1000C622 METAL CHIP 100 Ω 1 / 16 W J	nsp	R522		0RH0222C622 METAL CHIP 22 Ω 1 / 16 W J	nsp
R363				R525		0LC0233002B INDUCTOR CHIP HB-1S-800JT	nsp
R364		0RH4701C622 METAL CHIP 4.7k Ω 1 / 16 W J	nsp	R533		0RH0222C622 METAL CHIP 22 Ω 1 / 16 W J	nsp
R365		0RH1001C622 METAL CHIP 1k Ω 1 / 16 W J	nsp	R534		0RH1002C622 METAL CHIP 10k Ω 1 / 16 W J	nsp
R366		0RH1502C622 METAL CHIP 15k Ω 1 / 16 W J	nsp	R535		0RH0222C622 METAL CHIP 22 Ω 1 / 16 W J	nsp
R369		0RH3301C622 METAL CHIP 3.3k Ω 1 / 16 W J	nsp	R536		0RH0222C622 METAL CHIP 22 Ω 1 / 16 W J	nsp
R3A0				R580		0RH0222C622 METAL CHIP 22 Ω 1 / 16 W J	nsp
}		0RH0000C622 METAL CHIP 0 Ω 1 / 16 W J	nsp	R588			
R3A9				}		0RH0752C622 METAL CHIP 75 Ω 1 / 16 W J	nsp
R3F1		0RH0000C622 METAL CHIP 0 Ω 1 / 16 W J	nsp	R591			
R3F3		0RH0000C622 METAL CHIP 0 Ω 1 / 16 W J	nsp	R597		0RH0000C622 METAL CHIP 0 Ω 1 / 16 W J	nsp
R3F4		0RH1002C622 METAL CHIP 10k Ω 1 / 16 W J	nsp	R5B1		0RH0000C622 METAL CHIP 0 Ω 1 / 16 W J	nsp
R3F5		0RH1002C622 METAL CHIP 10k Ω 1 / 16 W J	nsp	R5B2		0RH0000C622 METAL CHIP 0 Ω 1 / 16 W J	nsp
R3F9		0RH1501C622 METAL CHIP 1.5k Ω 1 / 16 W J	nsp	R5B3		0RH0000C622 METAL CHIP 0 Ω 1 / 16 W J	nsp
R401		0RH0102C622 METAL CHIP 10 Ω 1 / 16 W J	nsp	R601		0RD1000F608 100 Ω 1/6 W J	nsp
R402		0RH4701C622 METAL CHIP 4.7k Ω 1 / 16 W J	nsp	R602		0RD1000F608 100 Ω 1/6 W J	nsp
R403				R618		0RD1003F608 100k Ω 1/6 W J	nsp
}		0RH0000C622 METAL CHIP 0 Ω 1 / 16 W J	nsp	R619		0RD1003F608 100k Ω 1/6 W J	nsp
R406				R620		0RD2200F608 220 Ω 1/6 W J	nsp
R407		0RH5601C622 METAL CHIP 5.6k Ω 1 / 16 W J	nsp	R621		0RD2200F608 220 Ω 1/6 W J	nsp
R408		0RH2201C622 METAL CHIP 2.2k Ω 1 / 16 W J	nsp	R622		0RD0222F608 22 Ω 1/6 W J	nsp
R409		0RH1801C622 METAL CHIP 1.8k Ω 1 / 16 W J	nsp	R633		0RD4701F608 4.7k Ω 1/6 W J	nsp
R410		0RH4701C622 METAL CHIP 4.7k Ω 1 / 16 W J	nsp	R677		0RD1001F608 1k Ω 1/6 W J	nsp
R411		0RH1801C622 METAL CHIP 1.8k Ω 1 / 16 W J	nsp	R6M1		0RD2200F608 220 Ω 1/6 W J	nsp
R412		0RH7501C622 METAL CHIP 7.5k Ω 1 / 16 W J	nsp	R6M2		0RD2200F608 220 Ω 1/6 W J	nsp
R413		0RH4701C622 METAL CHIP 4.7k Ω 1 / 16 W J	nsp	R6M3		0RD1003F608 100k Ω 1/6 W J	nsp
R414		0RH4701C622 METAL CHIP 4.7k Ω 1 / 16 W J	nsp	R6M4		0RD1003F608 100k Ω 1/6 W J	nsp
R415		0RH0102C622 METAL CHIP 10 Ω 1 / 16 W J	nsp	R903		0RD3301F608 3.3k Ω 1/6 W J	nsp
R416		0RH0102C622 METAL CHIP 10 Ω 1 / 16 W J	nsp	R904		0RD1000F608 100 Ω 1/6 W J	nsp
R417		0RH7501C622 METAL CHIP 7.5k Ω 1 / 16 W J	nsp	R905		0RD1001F608 1k Ω 1/6 W J	nsp
R418		0RH0102C622 METAL CHIP 10 Ω 1 / 16 W J	nsp	R907		0RD3300F608 330 Ω 1/6 W J	nsp
R419		0RH4700C622 METAL CHIP 470 Ω 1 / 16 W J	nsp	R912		0RD2201F608 2.2k Ω 1/6 W J	nsp
R420		0RH4700C622 METAL CHIP 470 Ω 1 / 16 W J	nsp	R913		0RD1501F608 1.5k Ω 1/6 W J	nsp
R421		0RH4701C622 METAL CHIP 4.7k Ω 1 / 16 W J	nsp	R914		0RD1201F608 1.2k Ω 1/6 W J	nsp
R422		0RH1002C622 METAL CHIP 10k Ω 1 / 16 W J	nsp	R915		0RD8200F608 820 Ω 1/6 W J	nsp
R423		0RH1002C622 METAL CHIP 10k Ω 1 / 16 W J	nsp	R916		0RD6800F608 680 Ω 1/6 W J	nsp

NOTE: "nsp" PART IS LISTED FOR REFERENCE ONLY, MARANTZ WILL NOT SUPPLY THESE PARTS.

POS. NO	VERS. COLOR	DESCRIPTION	PART NO. (MJI)	POS. NO	VERS. COLOR	DESCRIPTION	PART NO. (MJI)
R917		0RD1501F608 1.5k Ω 1/6 W J	nsp	P3101		6630R3S006C CONN. GT200 LG CABLE 10PIN	nsp
R918		0RD1201F608 1.2k Ω 1/6 W J	nsp	P3102		6630R3S006E CONN. GT200 LG CABLE 9PIN	nsp
R919		0RD8200F608 820 Ω 1/6 W J	nsp	P3301		6630HXC115A CONN. 04-6232-115-008-800	nsp
R920		0RD6800F608 680 Ω 1/6 W J	nsp	P3302		6630R-FB02F CONN. 04-6232-106-008-800 6PIN	nsp
R925		0RD1002F608 10k Ω 1/6 W J	nsp	P3901		6630R-FB02R CONN. 04-6232-118-008-800 18PIN	nsp
R926		0RD1002F608 10k Ω 1/6 W J	nsp	P4601		6630HXC126A CONN. 04-6232-126-008-800 26PIN	nsp
R928		0RD1002F608 10k Ω 1/6 W J	nsp	P6401		6630HXC126A CONN. GF102-26S-TS 26PIN	nsp
R929		0RD4702F608 47k Ω 1/6 W J	nsp	P9301		6630R-FB10R CONN. 00-6232-018-006-800 18PIN	nsp
R941		0RD4701F608 4.7k Ω 1/6 W J	nsp	P9901		6630S-BC02H CONN. B TO B P=1.25 8 PIN53045-081	nsp
R953		0RD8201F608 8.2k Ω 1/6 W J	nsp	P9901		6850R-GR26Z CABLE FLAT P=1.0 FFC UL2896(0.05X0.65) 18	nsp
R958		0RD4701F608 4.7k Ω 1/6 W J	nsp	P9902		6630S-BC01H CONN. B TO B P=1.25 8 PIN52061-081	nsp
R959		0RD3301F608 3.3k Ω 1/6 W J	nsp	PBK00		6871R-4461A PWB(PCB) ASSYTOTAL MM4021N KEY ASSY	nsp
R960		0RD2201F608 2.2k Ω 1/6 W J	nsp	PBT00		6871R-4460A PWB(PCB) ASSYTOTAL MM4021N KEY ASSY	nsp
R961		0RD3301F608 3.3k Ω 1/6 W J	nsp	PMD02		6630R-FB02W CONN. 04-6232-123-008-800 23PIN	nsp
R962		0RD3301F608 3.3k Ω 1/6 W J	nsp	PMD03		6630HXC122A CONN. 04-6232-122-008-800 22PIN	nsp
R963		0RD3301F608 3.3k Ω 1/6 W J	nsp	PW101		561-292B CONN. GP390 LGC 3P	nsp
R964		0RD3301F608 3.3k Ω 1/6 W J	nsp	RC901		6712R1636G1 IR RECEIVER TSOP2836RF1	*HW100540R
BC101	636-004C	MISCELLANEOUS COIL BEAD CORE BFS3550R2FD8	*FC900210R	SW602		6600R-SH18A SW TACT CSS-4206	*SS000730R
F101	585-027B	FUSE 1600MA 250 V 5.2X20	*FS000730R	SW901		556-219B SW TACT THVV502GAA	*SP001000R
F102	0IRH100000B	IC RW ICP-N10 T104	FU40115020	SW907		556-219B SW TACT THVV502GAA	*SP001000R
F602				SW910		556-219B SW TACT THVV502GAA	*SP001000R
F608	6200HJC901A	FILTER CFI06B1H101MF	nsp	SW911		556-219B SW TACT THVV502GAA	*SP001000R
F612	6200HJC901A	FILTER CFI06B1H101MF	nsp	SW912		556-219B SW TACT THVV502GAA	*SP001000R
F613	6200HJC901A	FILTER CFI06B1H101MF	nsp	SW914		556-219B SW TACT THVV502GAA	*SP001000R
FH101	586-008B	HOLDER FUSE CLIP	nsp	SW917		556-219B SW TACT THVV502GAA	*SP001000R
FH102	586-008B	HOLDER FUSE CLIP	nsp	T101		642-024E MAINS TRANSF. SJE-024E	*TS001590R
JK601	6612R-L007A	JACK FIBER OPTIC GP1FA550TZ SHARP VE	*YJ002520R	V101		656-004C VARISTOR SVC681D-10A	nsp
JK602	6612R-C006G	JACK RCA RCA DIN-11G YUQIU D.GND	*YT002660R	X201		6202R-BM01A X'TAL CHIP 33.8688MHz	*JX000850R
L101	616-145H	FILTER SHT LFS2020V4-04350	*FN000110R	X501		6202R-BL01A X'TAL CHIP 27MHz	*JX000660R
L102	633-088D	COIL CHOKE 20UH LEAD CUT	nsp	X901		6202R-BJ01A X'TAL 5.0000MHz	*JX000860R
L103	633-088G	COIL CHOKE 22mH TP 5MM	nsp				
L105	633-088G	COIL CHOKE 22mH TP 5MM	nsp				
L201							
L204	6200HJC102A	FILTER HB-1M2012-102JT	nsp				
L207	6200HJC102A	FILTER HB-1M2012-102JT	nsp				
L208	6200HJC102A	FILTER HB-1M2012-102JT	nsp				
L211	6200HJC102A	FILTER HB-1M2012-102JT	nsp				
L2A1	6200HJC102A	FILTER HB-1M2012-102JT	nsp				
L2A2	6200HJC102A	FILTER HB-1M2012-102JT	nsp				
L2A3	6200HJC102A	FILTER HB-1M2012-102JT	nsp				
L301	6200HJC102A	FILTER HB-1M2012-102JT	nsp				
L302	6200HJC102A	FILTER HB-1M2012-102JT	nsp				
L3F2							
L3F5	6200HJC102A	FILTER HB-1M2012-102JT	nsp				
L403	6200HJC102A	FILTER HB-1M2012-102JT	nsp				
L502	6200HJC102A	FILTER HB-1M2012-102JT	nsp				
L503	6200HJC102A	FILTER HB-1M2012-102JT	nsp				
L602	0LA0101K018	INDUCTOR 1.0M K 2.3X3.4 L5 TP	nsp				
L603	0LA0101K018	INDUCTOR 1.0M K 2.3X3.4 L5 TP	nsp				
L901	0LR1000K035	INDUCTOR 100UF K 6X6 L5 TP	nsp				
L902	0LR1000K035	INDUCTOR 100UF K 6X6 L5 TP	nsp				
LED901	0DL325319AA	LED SPR325MVWT31 GREEN/RED	*HI100860R				
P1301	563-602W	CONN. GIL-S/9072ST 10 PIN	nsp				
P1302	6631R-E009C	CONN. GIL-S/9073ST 9PIN	nsp				

NOTE : *nsp* PART IS LISTED FOR REFERENCE ONLY, MARANTZ WILL NOT SUPPLY THESE PARTS.

15. DVD DECK MECHANISM SECTION

CONTENTS

DECK MECHANISM PARTS LOCATIONS

- **Top View**.....2-2
- **Top View(without Tray Disc)**2-2
- **Bottom View**2-2

DECK MECHANISM DISASSEMBLY

1. Holder Assembly Clamp.....2-3

- 1-1. Plate Clamp2-3
- 1-2. Magnet Clamp2-3
- 1-3. Upper Clamp.....2-3
- 1-4. Holder Clamp.....2-3

2. Base Assembly Tray2-3

- 2-1. Tray Disc(Fig.4-2)2-3
- 2-2. Roller Base Tray2-3
- 2-3. PCB Assembly Tray2-3
- 2-4. Motor Assembly Tray2-3
- 2-5. Gear Tray.....2-3
- 2-6. Gear Wheel Tray2-3
- 2-7. Base Tray.....2-3

3. Frame Assembly Up/Down.....2-4

- 3-1. PCB Assembly Junction2-4
- 3-2. Base Assembly Sled Damper.....2-4
 - 3-2-1. Gear Assembly Feed2-4
 - 3-2-2. Gear Assembly Middle.....2-4
 - 3-2-3. Gear Assembly Rack2-4
- 3-3. Rubber Damper2-4
- 3-4. Frame Up/Down.....2-4

4. Base Assembly Main.....2-5

- 4-1. PCB Assembly Main Mode2-5
- 4-2. Gear Slider.....2-5
- 4-3. Gear Exchange.....2-5
- 4-4. Gear Main.....2-5
- 4-5. Gear Up/Down2-5
- 4-6. Gear Wheel Main.....2-5
- 4-7. Gear Loading2-5
- 4-8. Motor Assembly Main2-5
- 4-9. Base Main.....2-5

DECK MECHANISM ADJUSTMENT

1. Tools and Fixtures for SVC2-6

2. Install Process.....2-6

3. Adjustment Process.....2-7

EXPLODED VIEW

1. Deck Mechanism Exploded View and Parts list2-9

DECK MECHANISM PARTS LOCATION

• Top View (With Tray)

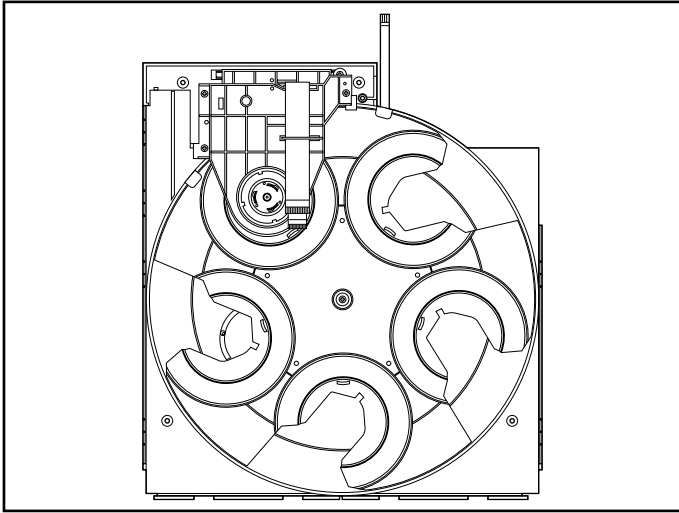

• Top View (Without Tray)

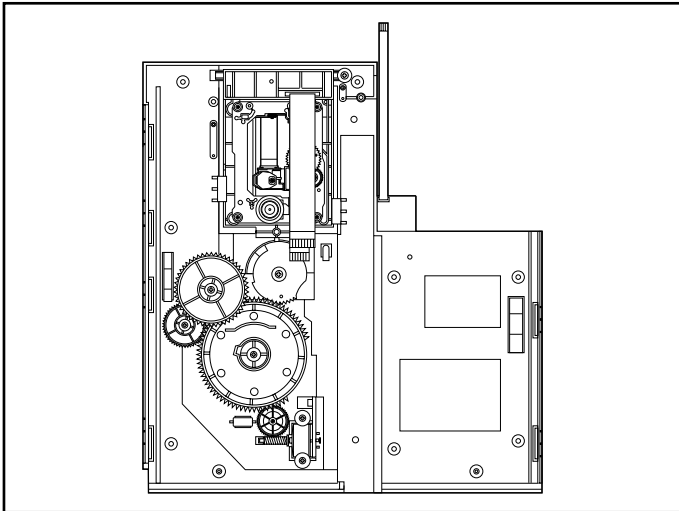

• Bottom View

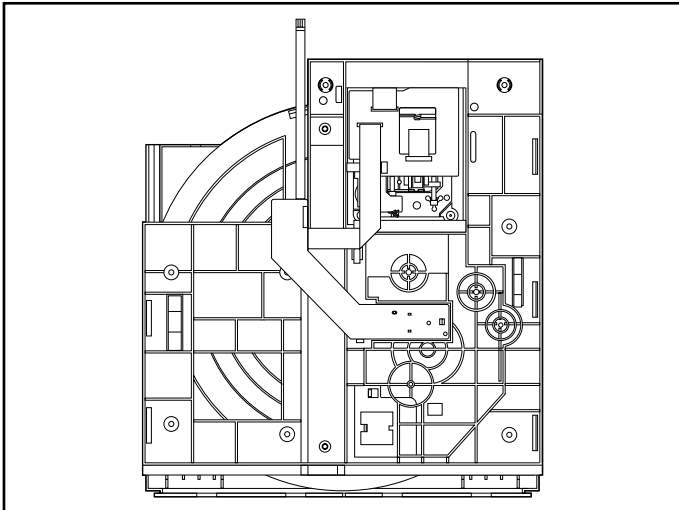

Procedure Starting No.	Parts	Fixing Type	Disassembly	Figure
1	Holder Assembly Clamp	3 Screws 2 Connectors 1 Hook	Top	4-1
1	2 Plate Calmp		Top	4-1
1,2	3 Magnet Clamp		Top	4-1
1,2,3	4 Upper Clamp		Top	4-1
1,2,3,4	5 Holder Clamp		Top	4-1
	6 Base Assembly Tray	2 Locking Tabs	Top	4-2
	7 Tray Disc	1 Screw	Top	4-2
6	8 Roller Base Tray	2 Locking Tabs	Bottom	4-2
6	9 PCB Assembly Tray	2 Screws 1 Connector	Bottom	4-2
6,7	10 Motor Assembly Tray	2 Screws	Top	4-2
6,7,10	11 Gear Tray		Top	4-2
6,7,10,11	12 Gear Wheel Tray		Top	4-2
6,7,8,9,10,11,12	13 Base Tray		Top	4-2
1	14 Frame Assembly Up/Down	1 Screw	Top	4-3
	15 PCB Assembly Junction	2 Screws 5 Connectors	Bottom	4-3
1	16 Base Assembly Sled Damper	4 Screws 1 Connector	Top	4-3
1	17 Gear Assembly Feed	1 Locking Tab	Top	4-3
1,17	18 Gear Middle		Top	4-3
1,17	19 Gear Assembly Rack	1 Screw	Top	4-3
1	20 Rubber Damper		Top	4-3
1,15,16,17,18,19,20	21 Frame Up/Down		Top	4-3
1,14	22 Base Assembly Main		Top	4-4
	23 PCB Assembly Main Mode	2 Connectors 3 Screws	Bottom	4-4
6	24 Gear Slider	1 Screw	Top	4-4
6,24	25 Gear Exchange	1 Screw	Top	4-4
6,24	26 Gear Main	1 Screw	Top	4-4
6,24,26	27 Gear Up/Down	1 Screw	Top	4-4
6,24,26	28 Gear Wheel Main	1 Screw	Top	4-4
6,24,26,28	29 Gear Loading		Top	4-4
6,28	30 Motor Assembly Main	2 Screws 1 Locking Tab	Top	4-4
1,6,14,23,24,25,26,27,28,29,30	31 Base Main		Top	4-4

Note

When reassembling, perform the procedure in reverse order.

The "Bottom" on Disassembly column of above Table indicates the part should be disassembled at the Bottom side.

DECK MECHANISM DISASSEMBLY

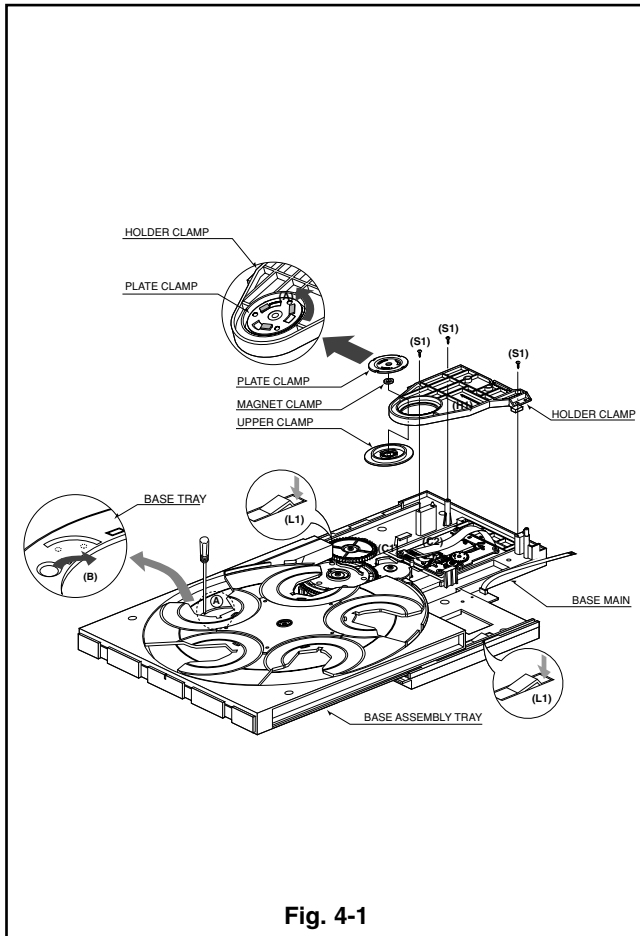

Fig. 4-1

1. Holder Assembly Clamp(Fig. 4-1)

- 1) Release 3 Screws(S1).
- 2) Unlock The Connectors (C1), (C2) from the Hook(H1).

1-1. Plate Clamp

- 1) Hold and fix the Upper Clamp under the Holder Assembly Clamp, and then turn the Plate Clamp to the counterclockwise direction(arrow(A)).

1-2. Magnet Clamp

1-3. Upper Clamp

1-4. Holder Clamp

Note

- When reassembling, hold and fix the Upper Clamp as above No. 1-1(1), and then turn the Plate Clamp to the clockwise direction.

2. Base Assembly Tray(Fig. 4-1)

- 1) Turn the (A) portion to the direction of arrow(B) to move the Base Assembly Tray in front of you.
- 2) Push down two Locking Tabs(L1) located to both sides of the Base Main, and then pull the Base Assembly Tray in front of you.

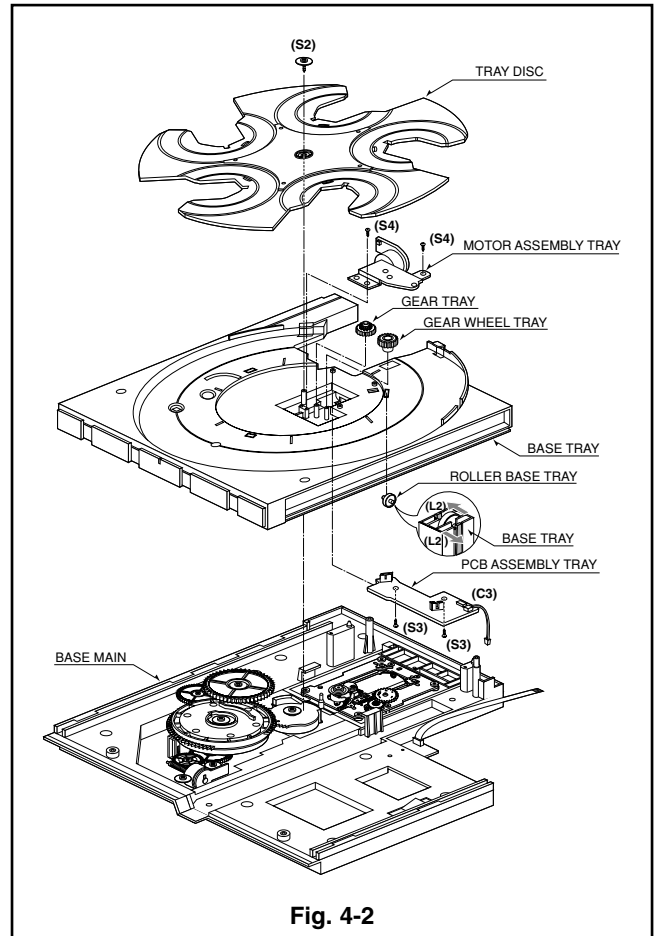

Fig. 4-2

2-1. Tray Disc(Fig.4-2)

- 1) Release Screw(S2).

Note

- Put the Base Assembly Tray face down(Bottom side).

2-2. Roller Base Tray

- 1) Unlock the two Locking Tabs(L2).

2-3. PCB Assembly Tray

- 1) Release two Screws(S3).
- 2) Unconnect the Connector(C3).

Note

- Put the Base Assembly Tray on original position(Top Side).

2-4. Motor Assembly Tray

- 1) Release 2 Screws(S4).

2-5. Gear Tray

2-6. Gear Wheel Tray

2-7. Base Tray

DECK MECHANISM DISASSEMBLY

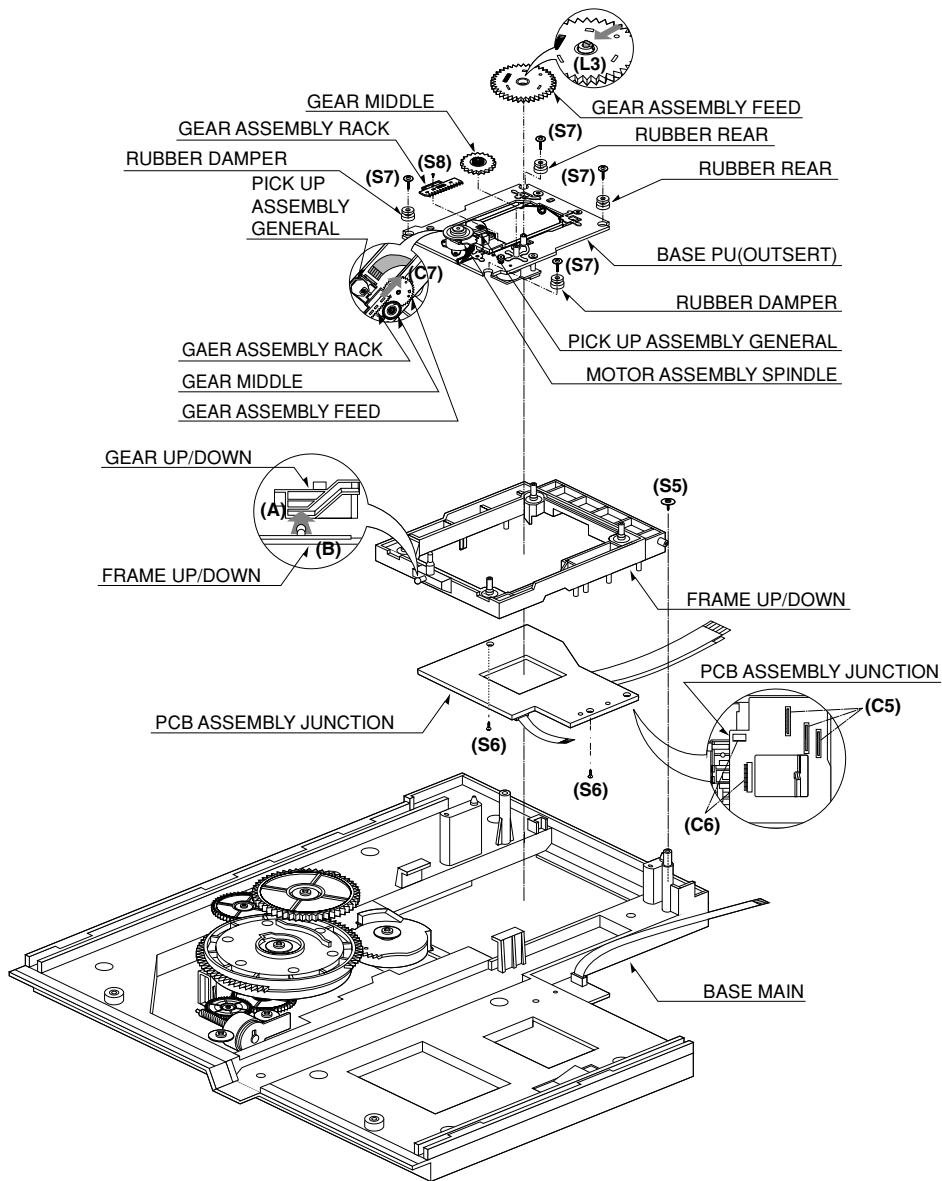

Fig. 4-3

3. Frame Assembly Up/Down (Fig. 4-3)

- 1) Release Screw (S5).

3-1. PCB Assembly Junction

- 1) Unconnect the 5 Connectors (C5), (C6).
- 2) Release 2 Screws (S6).

3-2. Base Assembly Sled Damper

- 1) Release 4 Screws (S7).
- 2) Disconnect the Connector (C7).

3-2-1. Gear Assembly Feed

- 1) Look the Locking Tab (L3) in direction of arrow.

3-2-2. Gear Assembly Middle

3-2-3. Gear Assembly Rack

- 1) Release the Screw (S8).

3-3. Rubber Damper

3-4. Frame Up/Down

Note

- Put the Base Assembly Main on original position (Top side)

DECK MECHANISM DISASSEMBLY

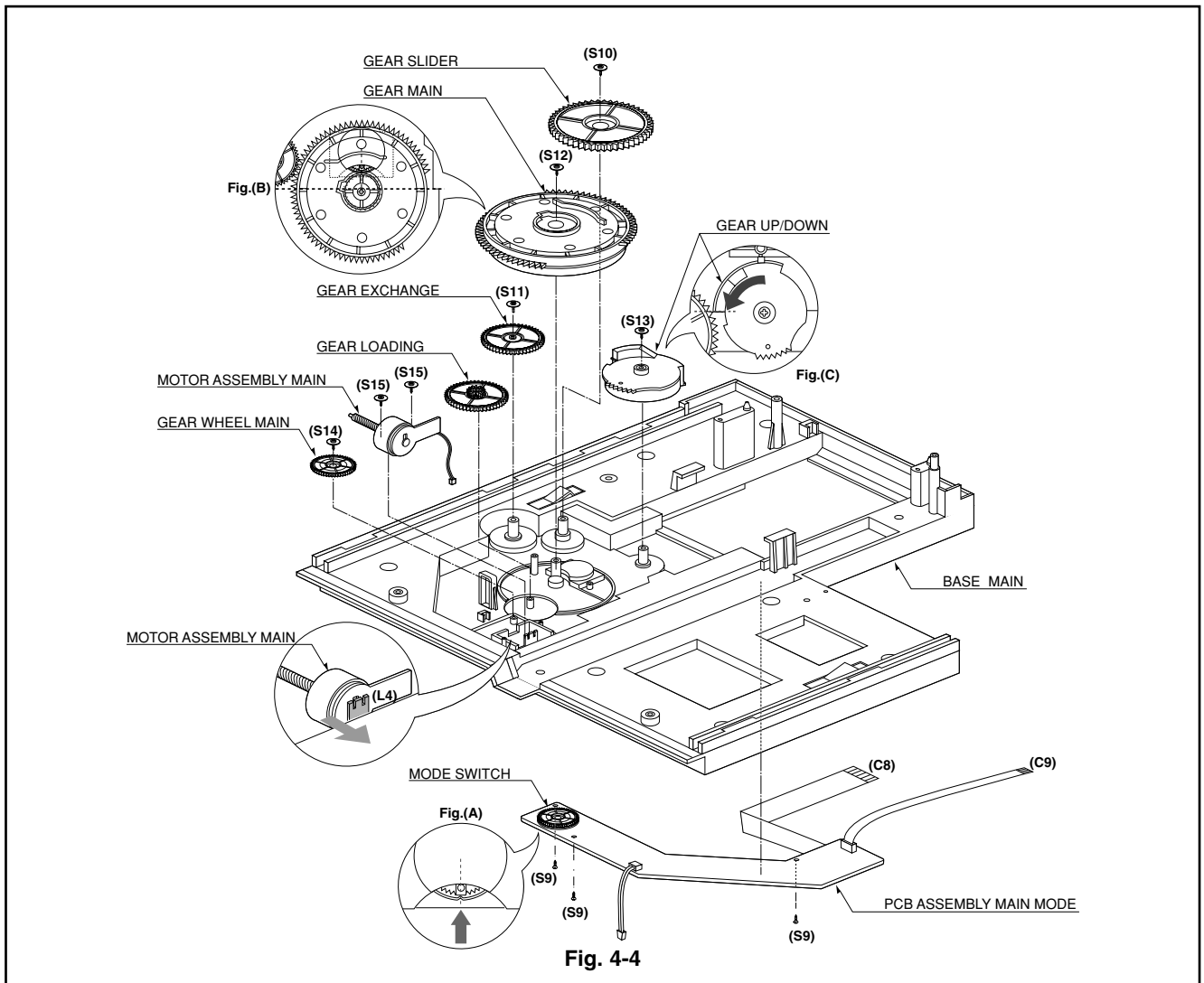

Fig. 4-4

4. Base Assembly Main(Fig. 4-4)

Note

- Put the Base Assembly Main face down(Bottom Side).

4-1. PCB Assembly Main Mode

- 1)Unconnect the Connectors (C8), (C9).
- 2)Release three Screws(S9).

Note

- When reassembling, align the Mode Switch position as Fig.(A).
- Put the Base Assembly Main on original position(Top Side)

4-2. Gear Slider

- 1) Release Screw(S10).

4-3. Gear Exchange

- 1) Release Screw(S11).

4-4. Gear Main

- 1) Release Screw(S12).

Note

- When reassembling, align the (A) position of the Gear Main to the (B) position of Mode Switch as Fig.(B)

4-5. Gear Up/Down

- 1) Release Screw(S13).

Note

- Reassembling, turn the Gear Up/Down in direction of arrow as Fig.(C).

4-6. Gear Wheel Main

- 1) Release Screw(S14).

4-7. Gear Loading

4-8. Motor Assembly Main

- 1) Release 2 Screws(S15).
- 2) Unlock the Locking Tab(L4).

4-9. Base Main

DECK MECHANISM ADJUSTMENT

1. Tools and Fixtures for SVC

• For SVC Program Down-Load

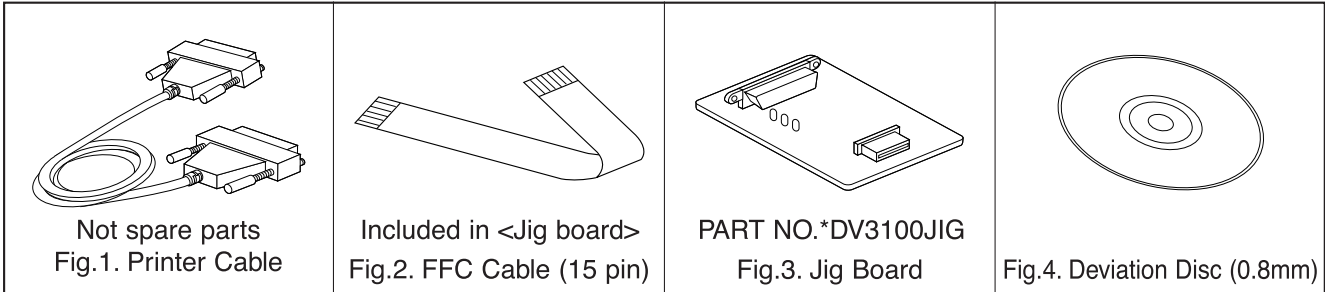

• For T-Skew and R-Skew Adjustment

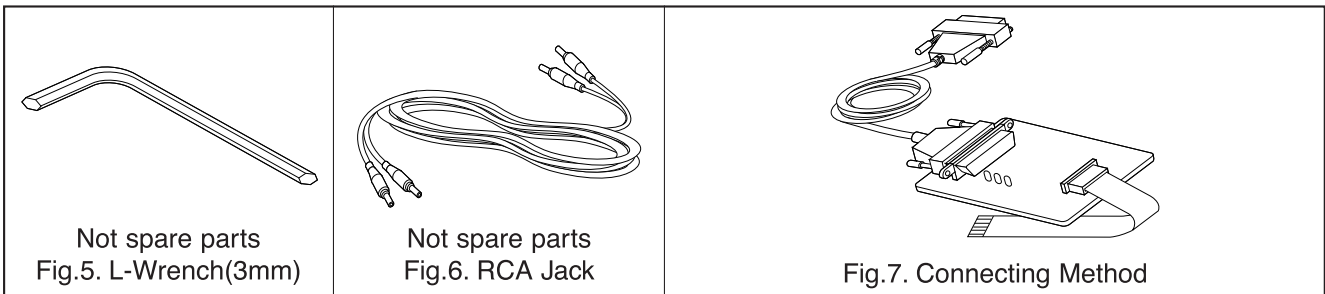

2. Install Process

1. Connect Fig. 1, 2, 3 as Fig. 7.
2. Plug out the Power cord of DVD set.
3. Connect FFC Cable(Fig.2) to the Connector on DVD Set(Fig.8)
4. Connect Printer Cable(Fig.1) to the P.C.Printer Port (LPT1).
5. Plug in the DVD Power cord.
6. Press the Menu key on Remocon.
7. Confirm No.1 LED(RED Color) of Jig board is ON. (Fig.9)
8. Perform The S/W for Down-load at P.C.
9. Open the Program File for Adjusting(Fig.10)
10. Click the Down-load Icon and perform Program Down-load.
11. Displayed remaining time.
12. Confirm LED No.1(RED) and No.2(RED) is ON.
13. Plug out the DVD Set Power cord.
14. Disconnect the FFC Cable.

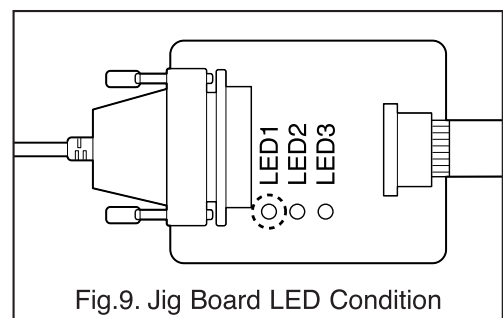
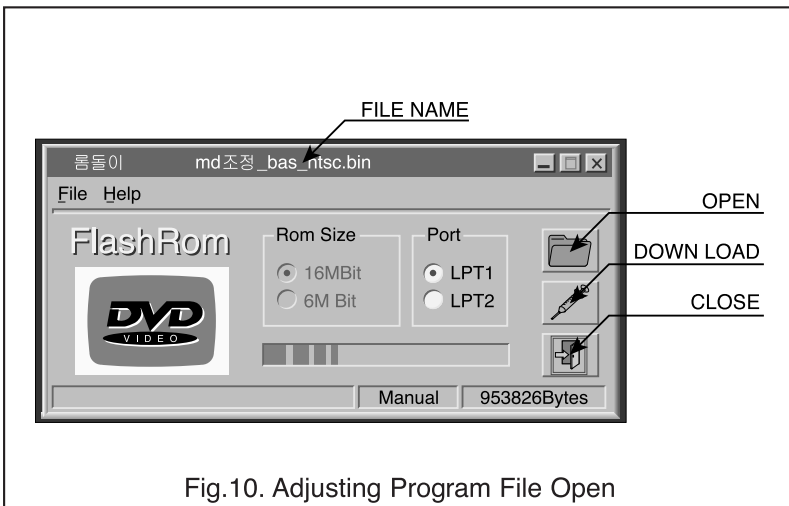
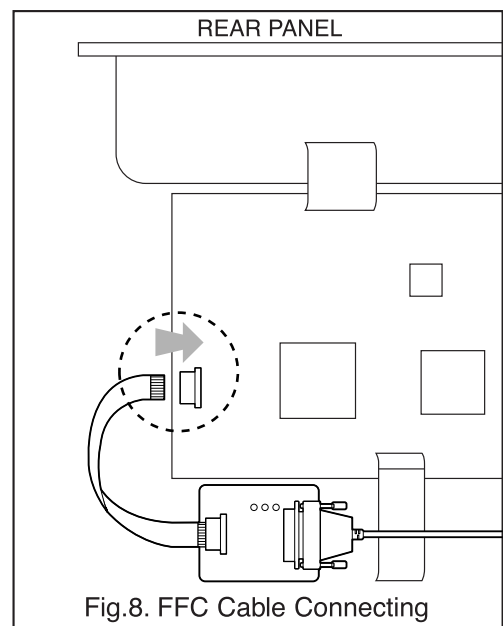

EXPLODED VIEWS

1. Deck Mechanism Exploded View and Parts list

POS. NO.	VERS. COLOR	DESCRIPTION	PART NO. (MJI)
A01		4931R-0037A HOLDER ASSY CLAMP	346W005510
A02		3041R-0014B BASE ASSY TRAY (DPM1)	346W163510
A03		3041R-0022B BASE ASSY SLED-DAMPER	346W304510
A04		3041R-0016A BASE ASSY MAIN	346W304520
001		3300R-0547A PLATE CLAMP	nsp
002		5016H-1016B MAGNET CLAMP	nsp
003		4860R-0009A CLAMP UPPER	nsp
004		4930R-0197A HOLDER CLAMP	346W005010
008		4470R-0047A GEAR ASSY RACK	304W058010
009		4470R-0053A GEAR MIDDLE	304W058020
011		3210R-0041A FRAME UP/DOWN	346W401010
012		5040R-0047D RUBBER DAMPER	346W259010
013		6871R-0001J PCB ASSY DPM1 JUNCTION DVD-CD R/RW	*ZZ001750R
014		5040R-0047A RUBBER REAR(E2,5040H-1054A),YAMAUCHI	346W259020
016		4470R-0050A GEAR ASSY FEED	304W058030
020		4470R-0073A GEAR WHEEL TRAY	346W058010
021		4470R-0074A GEAR TRAY	346W058020
022		6871R-3024C PCB ASSY DPM1 TRAY	*ZZ001760R
023		4580R-0006A ROLLER BASE TRAY	346W358010
024		4681R-0010C MOTOR ASSY TRAY	*MM001120R
025		3040R-0032A BASE TRAY (DPM1)	346W163010
026		3390R-0008A TRAY DISC (DPM1)	346W163020
030		3040R-0031A BASE MAIN (DPM1)	nsp
031		4470R-0069A GEAR SLIDER	346W058030
032		4470R-0067A GEAR MAIN	346W058040
033		4470R-0070A GEAR EXCHANGE	346W058050
034		4470R-0068A GEAR UP/DOWN	346W054010
035		4470R-0071A GEAR LOADING	346W058060
036		4681R-0012A MOTOR ASSY MAIN	*MM001130R
037		4470R-0072A GEAR WHEEL MAIN	346W058070
038		6871R-3026B PCB ASSY DPM1 MAIN-MODE	*ZZ001770R
413		4000R-0006A SCREW TAPTITE 3x8(353-025B)	nsp
414		4000R-0006B SCREW TAPTITE 3x8	nsp
416		4404R-0017A SCREW TAPTITE	nsp
430		1SZZH-1003A SCREW +D2.0 6MM SWRCH16A/NIY 4.5MM	nsp
432		1SZZR-0011A SCREW MACHINE	nsp

NOTE : "nsp" PART IS LISTED FOR REFERENCE ONLY, MARANTZ WILL NOT SUPPLY THESE PARTS.

