

MA6900

INTEGRATED AMPLIFIER

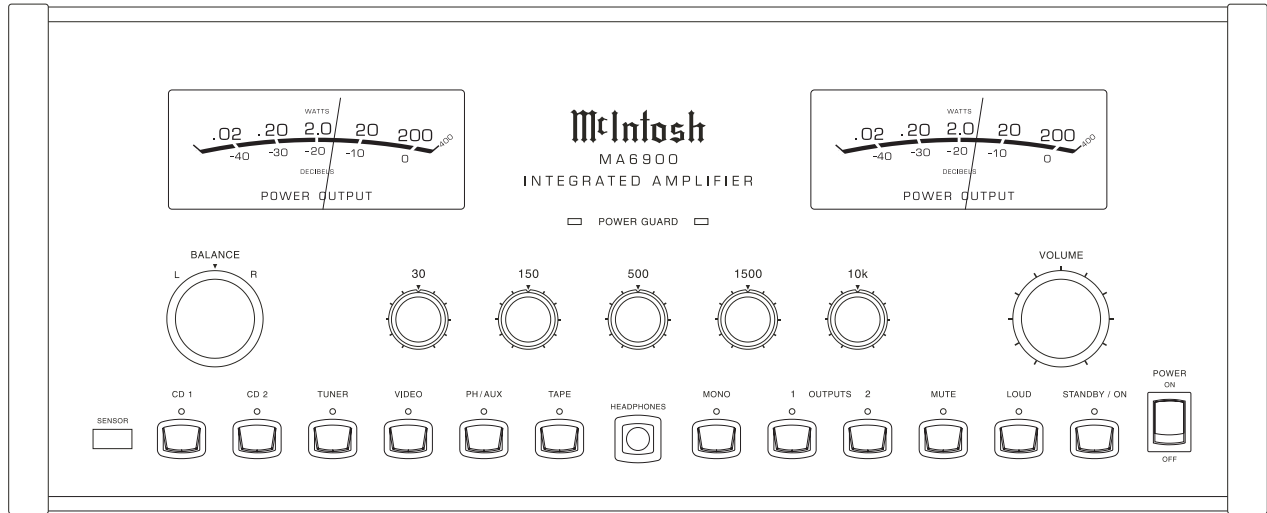

CONTENTS

Performance Specifications	2	Capacitor Schematic and PCB	21 - 22
Notes	2	Control Schematic and PCB	23 - 26
Rear Panel	3	Lamp Schematic and PCB	25 - 26
Section Location	4	Tone Schematic and PCB	27 - 31
Block Diagram	5 - 6	Keyboard Schematic and PCB	30 - 32
Interconnection Diagram	7 - 8	Parts List	33 - 36
Main Schematic and PCB	9 - 18	Exploded Views and Parts Lists	37 - 40
Balanced Schematic and PCB	12, 18	Repacking Instruction	41
Heatsink Schematic and PCB	19 - 20		

McIntosh®

SERVICE MANUAL

PERFORMANCE SPECIFICATIONS

Power Output

Minimum sine wave continuous average power output per channel, all channels operating is:

200 watts into 2 ohm load

200 watts into 4 ohm load

200 watts into 8 ohm load

Rated Power Band

20Hz to 20,000Hz

Total Harmonic Distortion

Maximum Total Harmonic Distortion at any power level from 250 milliwatts to rated power output is:

0.005% for 2, 4 or 8 ohm loads

Dynamic Headroom

2.4dB

Frequency Response

+0, -0.5dB from 20Hz to 20,000Hz

+0, -3dB from 10Hz to 100,000Hz

Sensitivity

Phono, 2.5mV for 2.5V rated output (0.5mV IHF)

High Level, 250mV for 2.5V rated output (50mV IHF)

Power Amplifier Input, 2.5V for rated output

Signal To Noise Ratio (A Weighted)

90dB (84dB IHF) below 10mV input, Phono Input

100dB (90dB IHF) below rated output, High Level

110dB below rated output, Power Amplifier

Intermodulation Distortion

Maximum Intermodulation Distortion if instantaneous peak output per channel does not exceed twice the rated output, for any combination of frequencies from 20Hz to 20,000Hz, with all channels operating is:

0.005% for 2, 4 or 8 ohm loads

Input Impedance

Phono, 47k ohms, 65pF

High Level, 22k ohms

Maximum Input Signal

Phono, 90mV

High Level, 8V

Preamplifier Maximum Voltage Output

Phono, 8V at tape output

High Level, 8V at tape output

Main Out, 8V at preamp output

Voltage Gain

High Level to Tape: 0dB

High Level to Main: 20dB

Wide Band Damping Factor

Greater than 40

Power Requirements

100 Volts, ~ 50/60Hz at 4.8 amps

110 Volts, ~ 50/60Hz at 4.4 amps

120 Volts, ~ 50/60Hz at 4.2 amps

220 Volts, ~ 50/60Hz at 2.0 amps

230 Volts, ~ 50/60Hz at 2.0 amps

240 Volts, ~ 50/60Hz at 2.0 amps

Note: Refer to the rear panel of the MA6900 for the correct voltage.

Overall Dimensions

Front Panel: 17-1/2 inches (44.45cm) wide, 7-1/8 inches

(18.10cm) high. Depth behind front mounting panel is 16-1/2

inches (41.91cm). Clearance required in front of the Front Panel

is 1 inch (2.54cm) for knobs.

Weight

74.5 pounds (33.8 Kg) net, 92.5 pounds (41.7 Kg) in shipping carton

NOTES

1. The heavy lines on the schematic denote the primary signal path.
2. Unless otherwise noted, all voltages indicated on the schematics are measured under the following conditions:
 - a. AC input at 120 volts, 50/60Hz.
 - b. All voltages are +/-10% with respect to ground. A high impedance (10 megaohm) voltmeter must be used.
3. Unless otherwise specified:
 - a. Resistor values are in ohms.
 - b. Capacitor values are microfarads (uF).
 - c. Inductor values are in microhenries (uH).
4. On PC board drawings, Square pad indicates:
 - a. Polarized Capacitors - Positive
 - b. Diodes - Cathode
 - c. Others - Pin 1
5. **WARNING**
Parts marked with the symbol  have critical characteristics. Use only replacement parts recommended by the manufacturer.

REAR PANEL

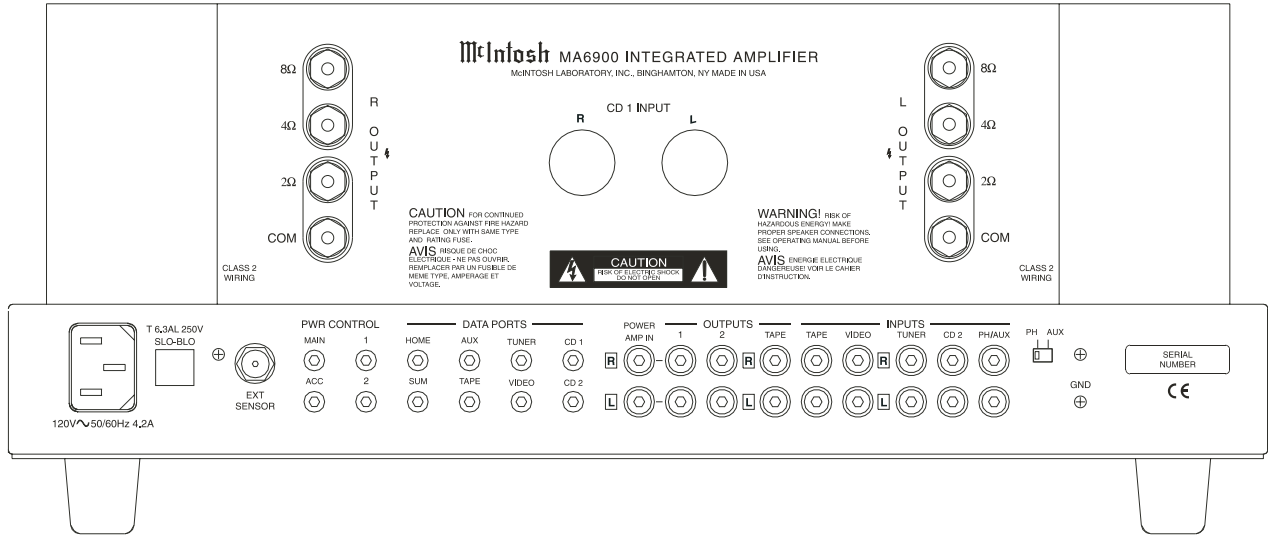

SECTION LOCATIONS

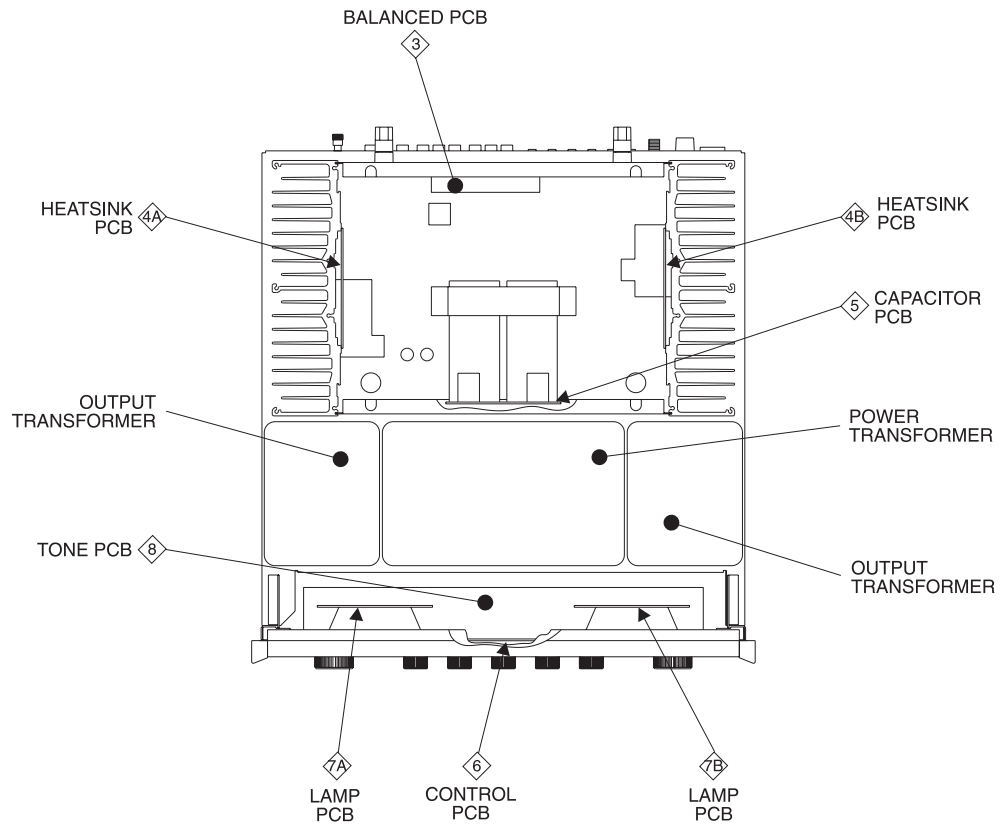

TOP VIEW WITH COVER REMOVED

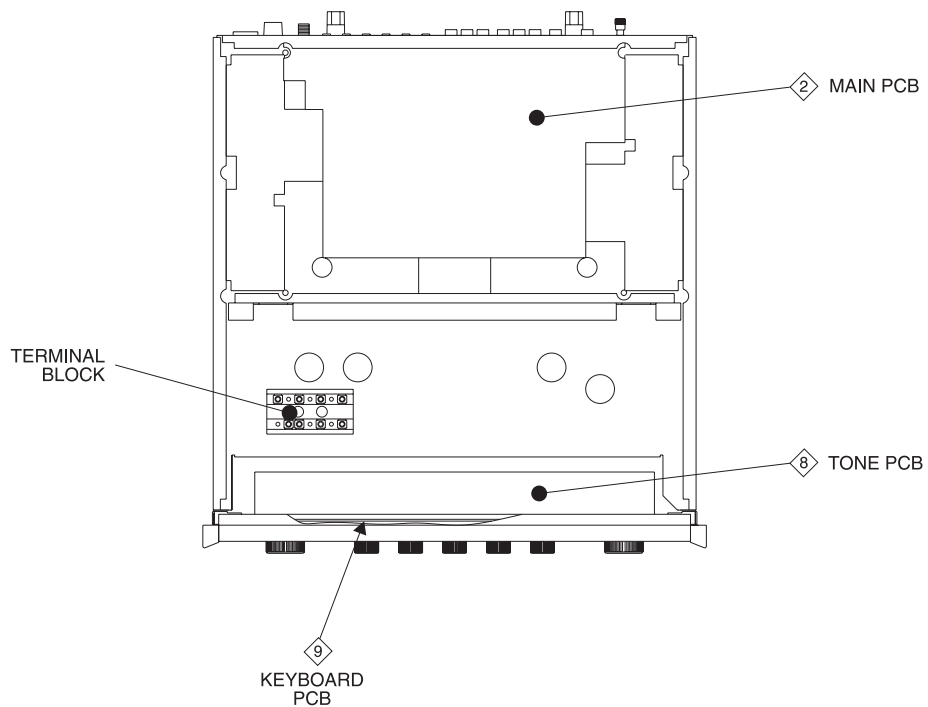

BOTTOM VIEW WITH COVER REMOVED

BLOCK DIAGRAM

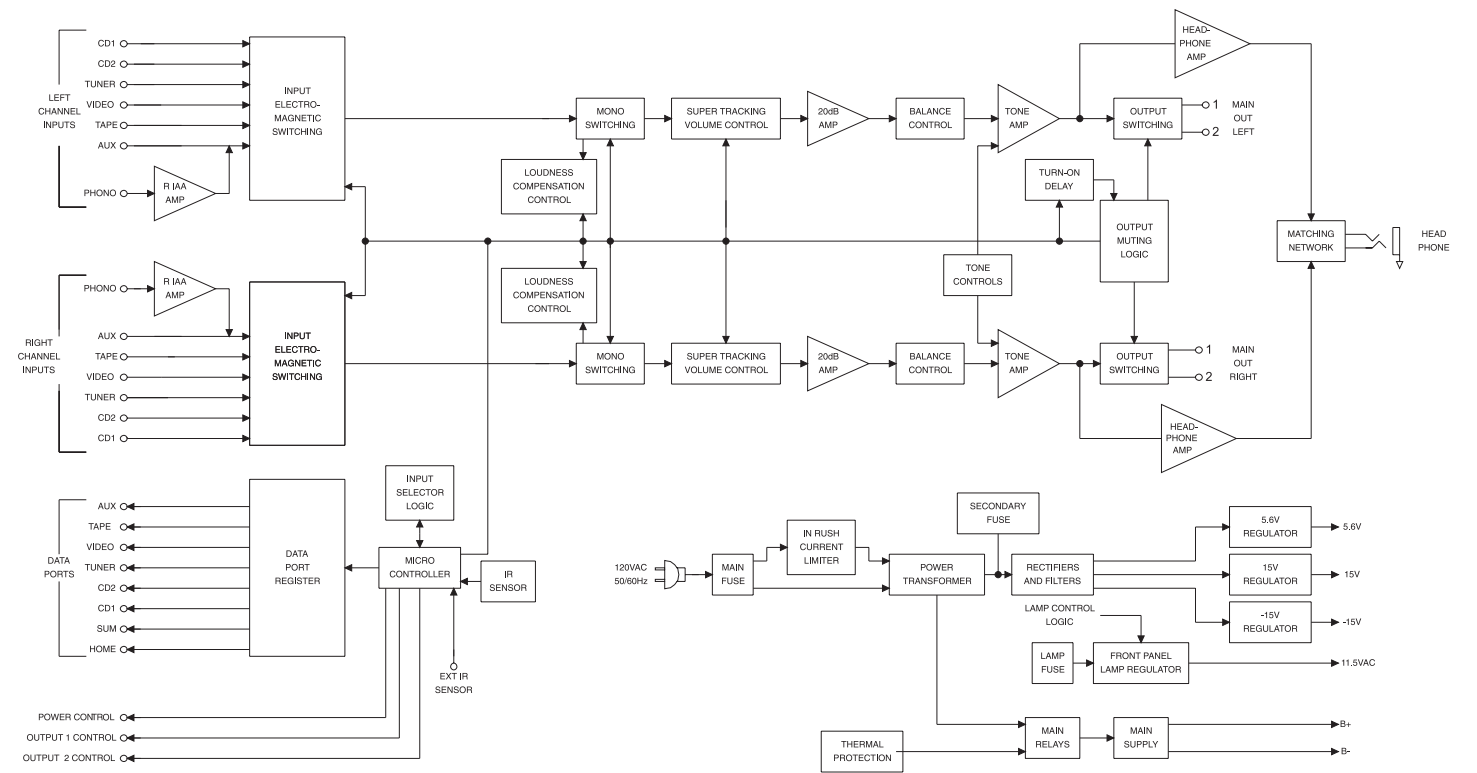
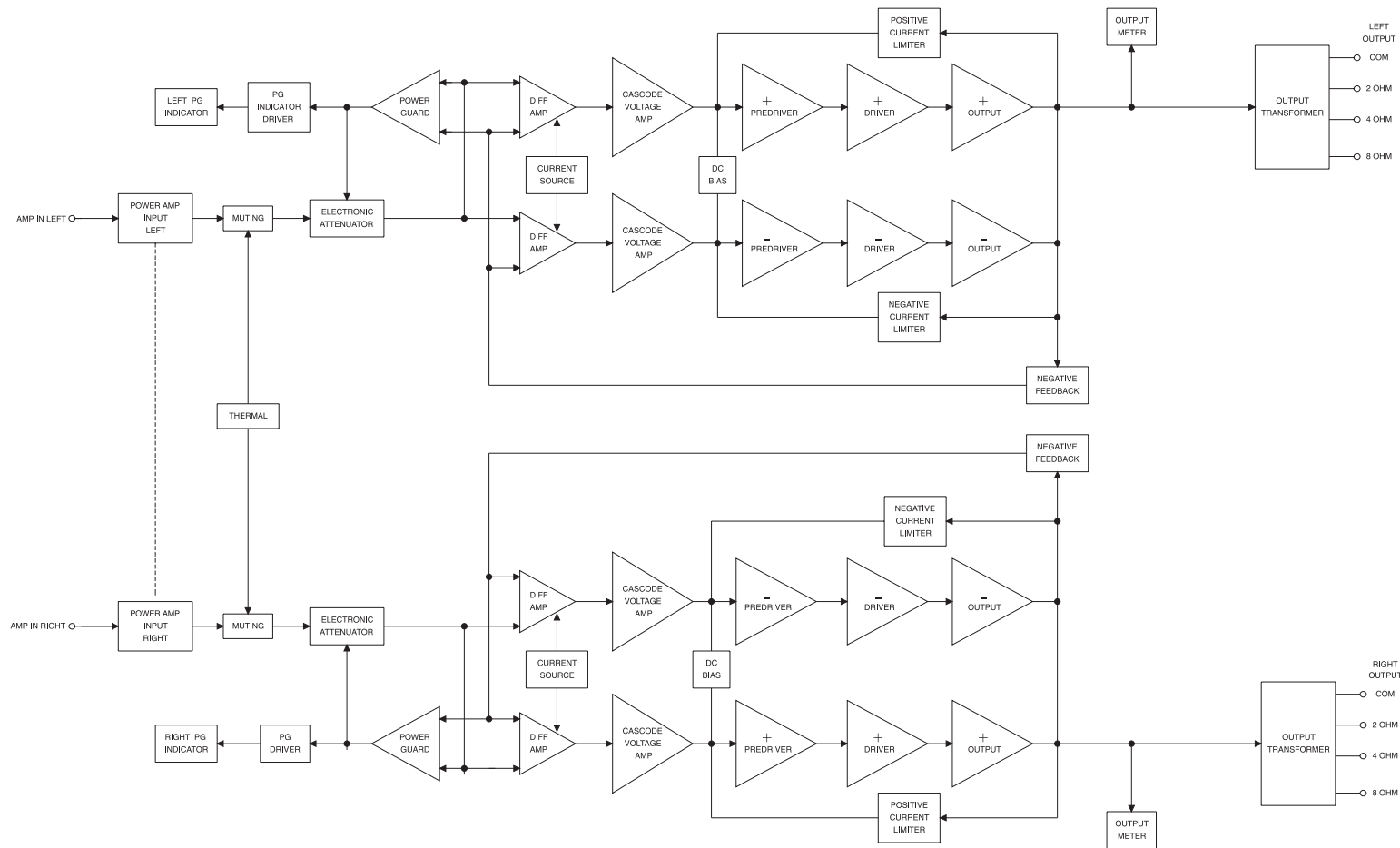

1 INTERCONNECT

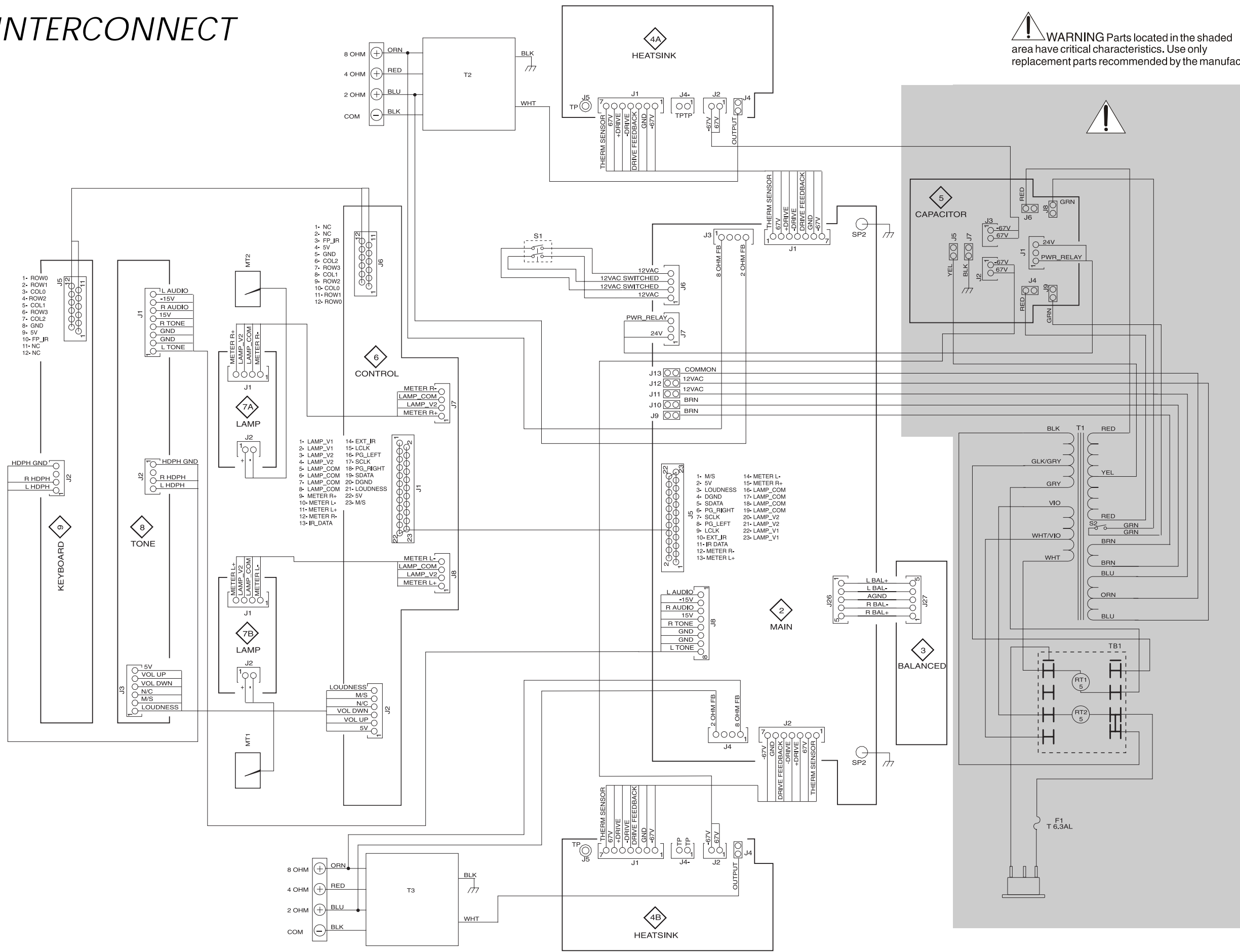

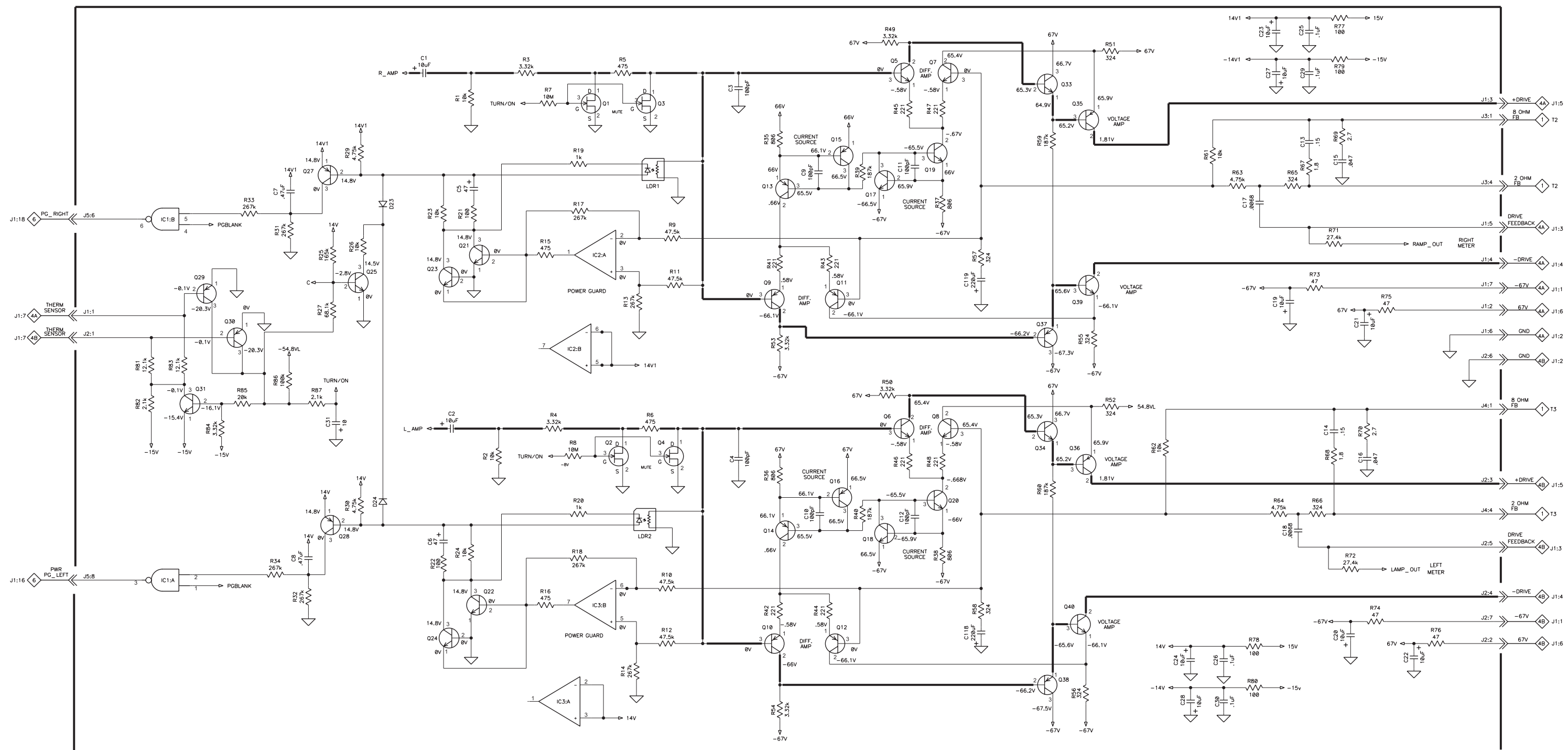

Power Table							
Ref Des	Device(Type)	Package	14V1	-14V1	-6V	-14V15V14V5V	DGND
IC1	133161	133161					14 7
IC2	13302B	13302B	B	4			
IC3	13302B	13302B			4	B	
IC16	13302B	13302B			4	B	
IC17	133260	133260			4	B	

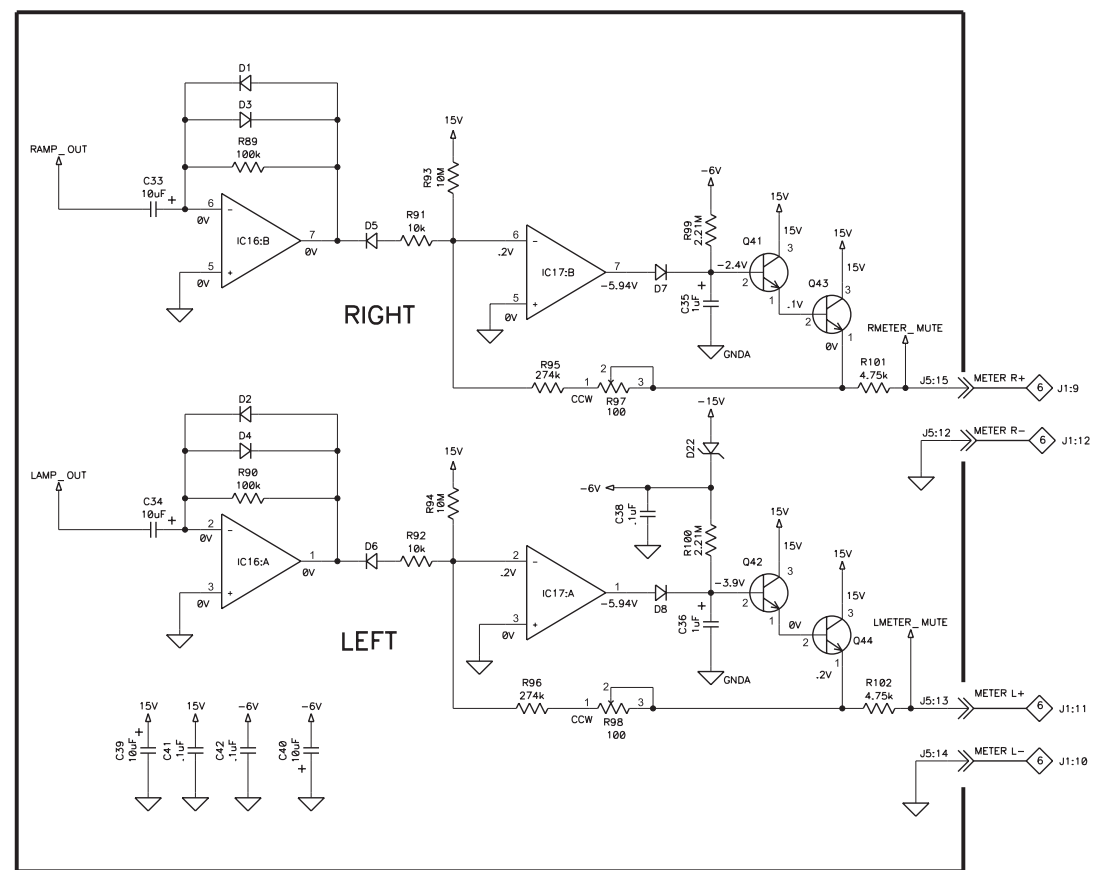

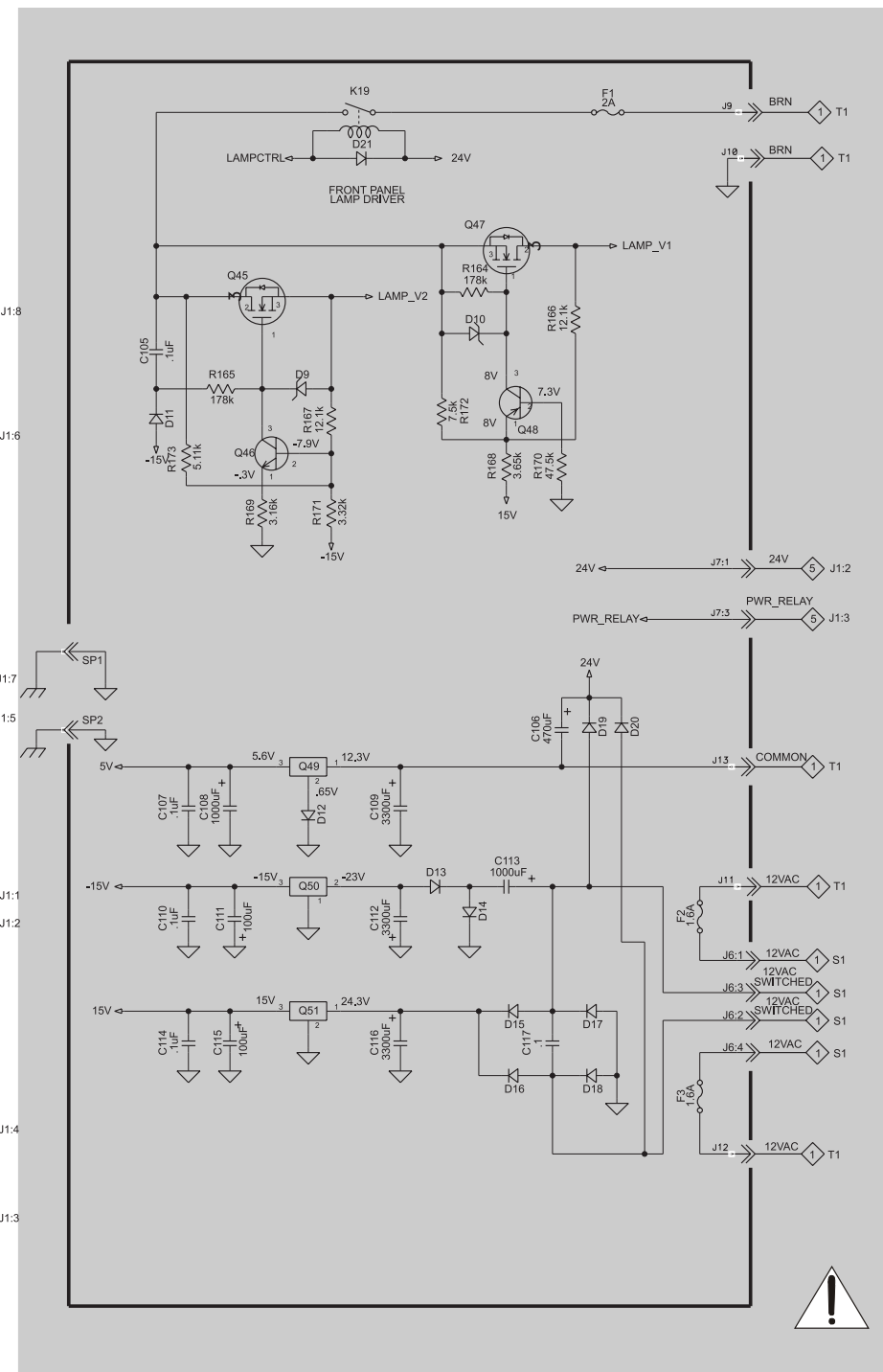
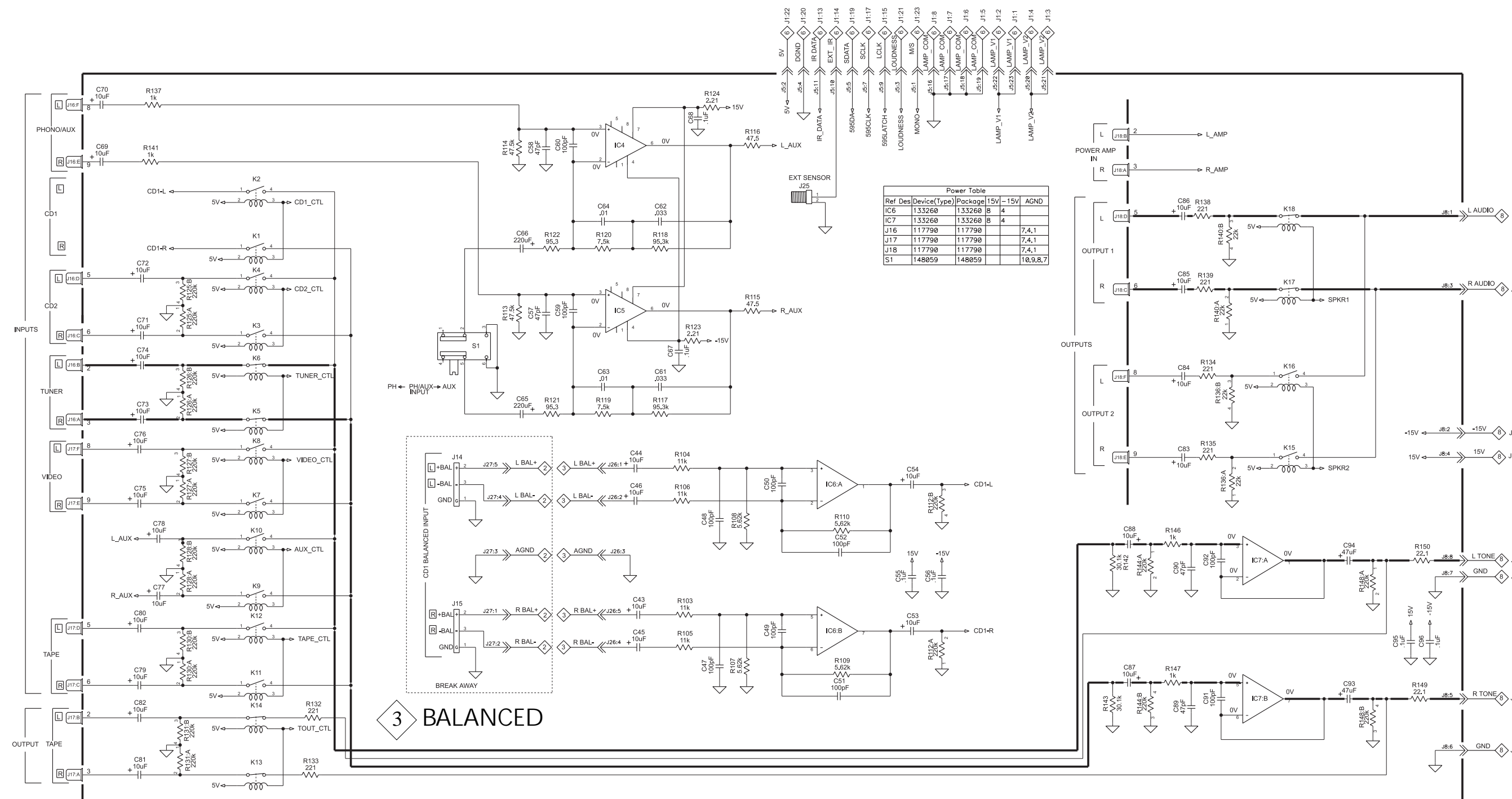

WARNING Parts located in the shaded area have critical characteristics. Use only replacement parts recommended by the manufacturer.

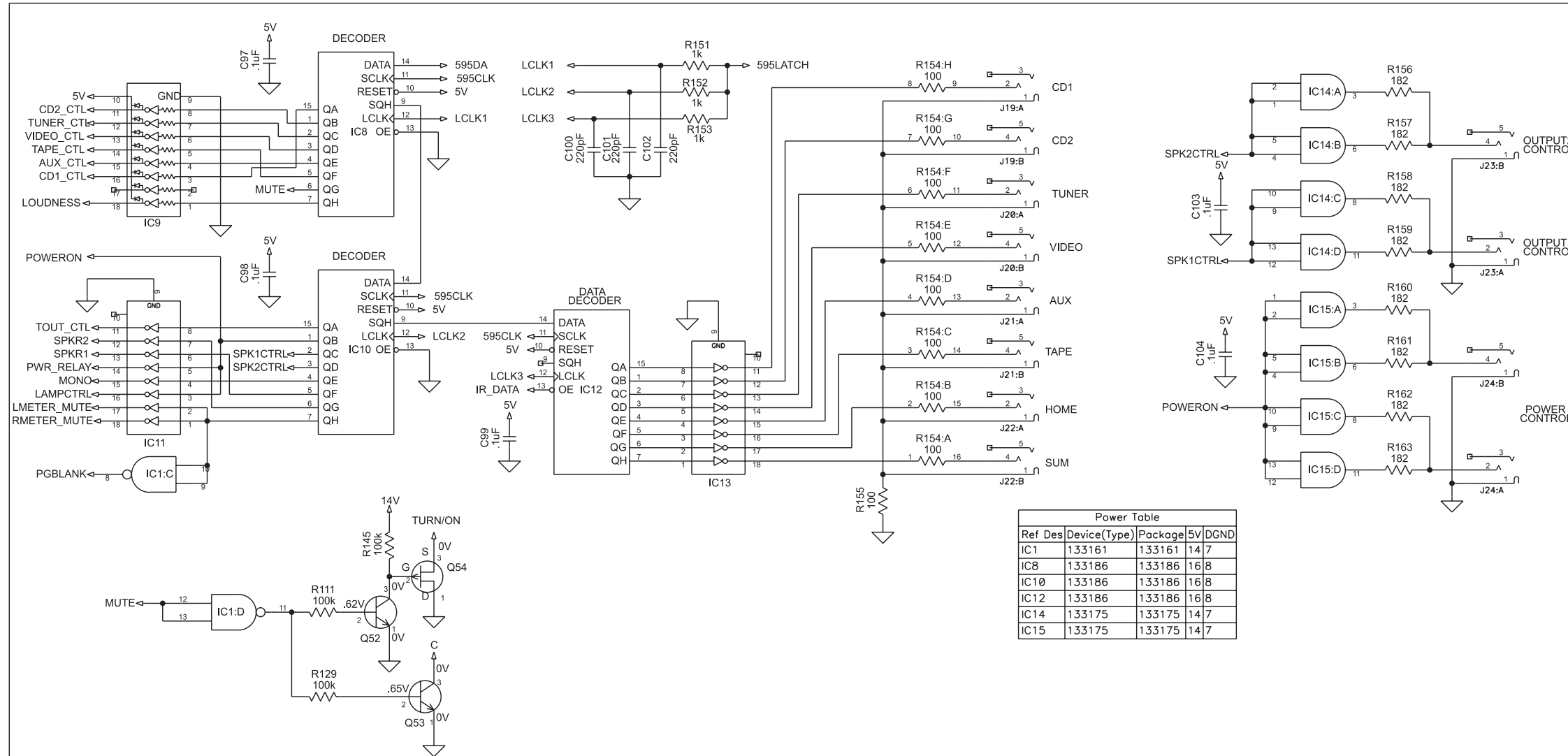

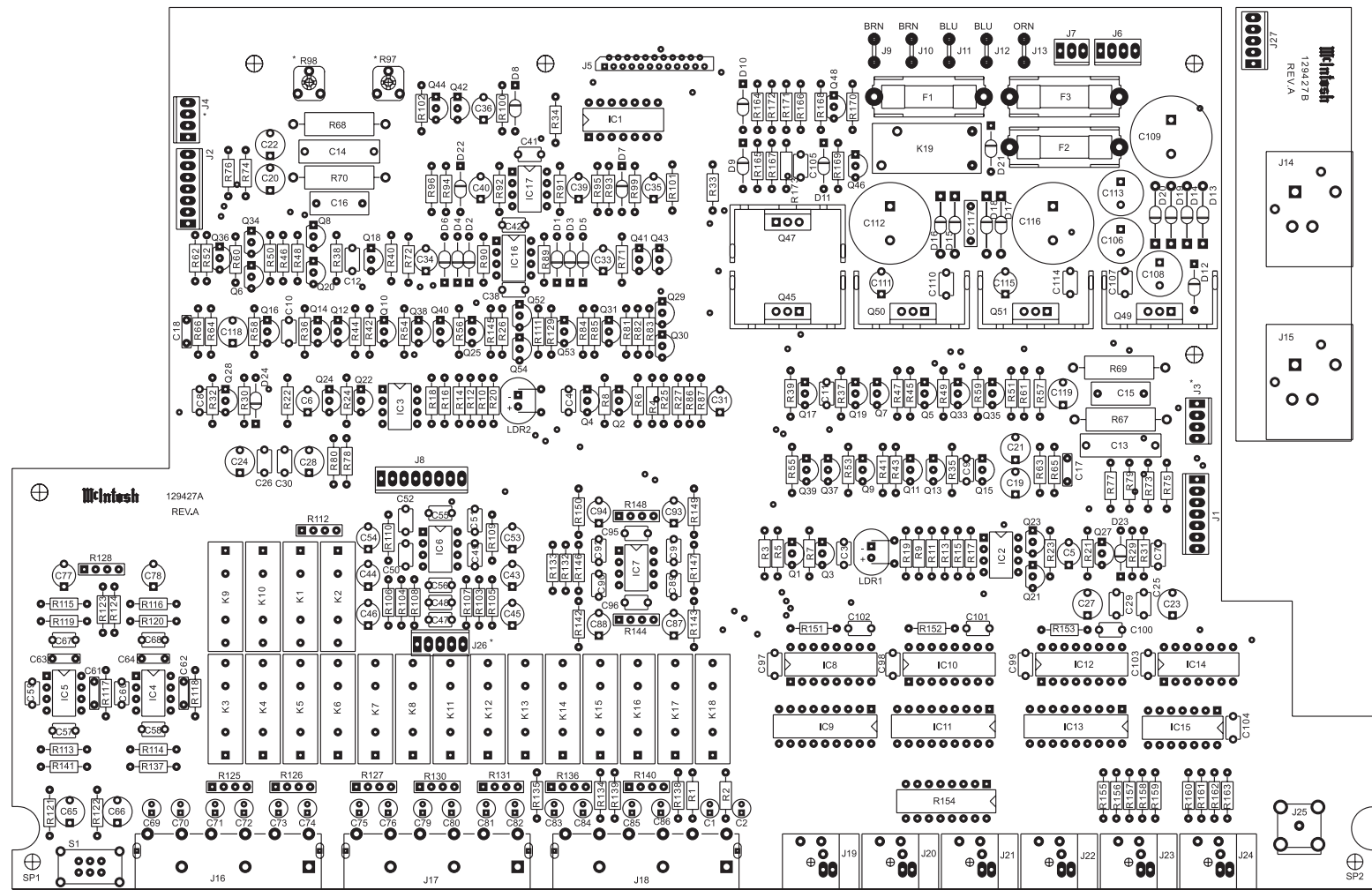

*DENOTES COMPONENTS ON REVERSE OR BACKSIDE OF PC BD

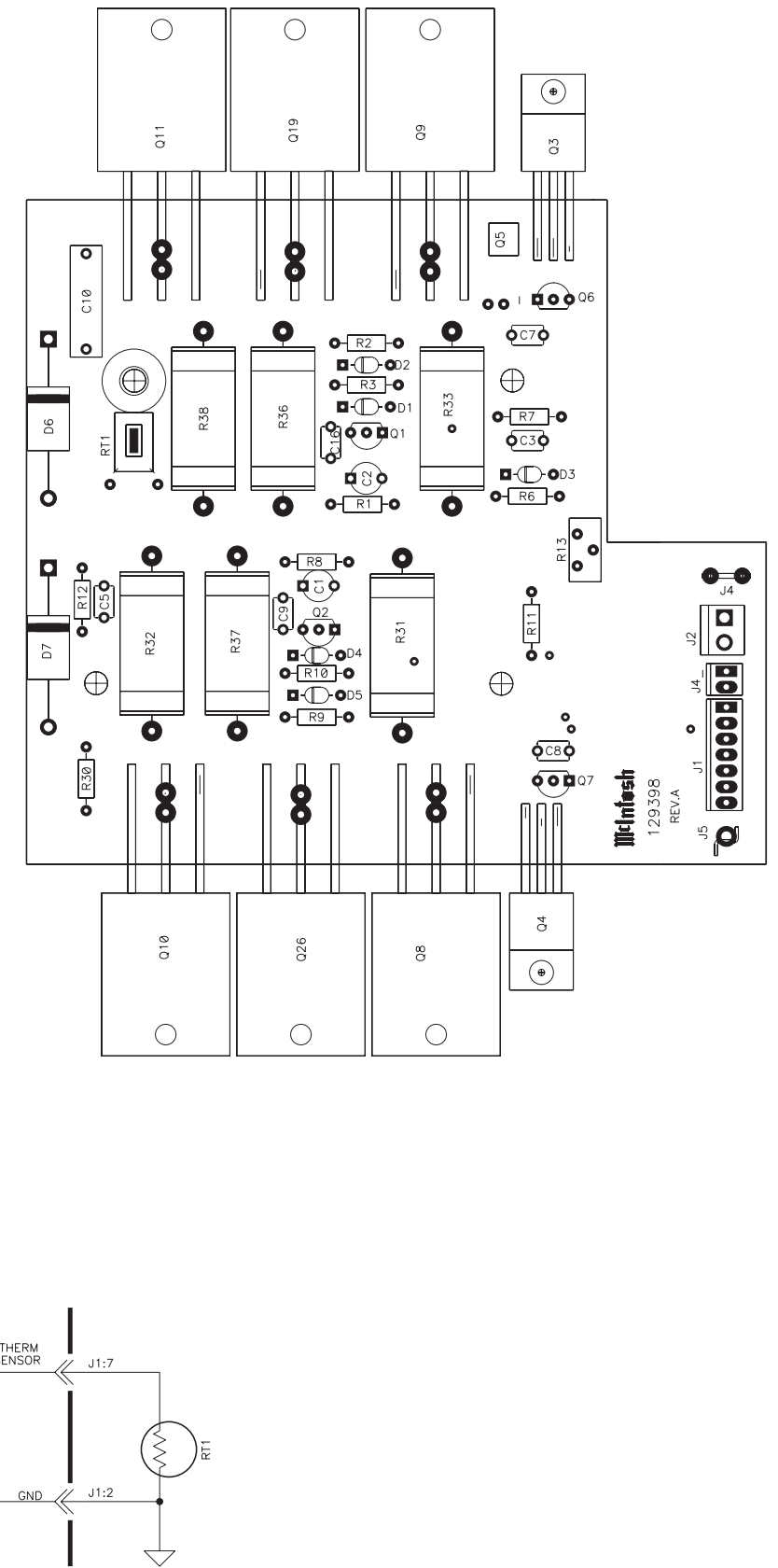
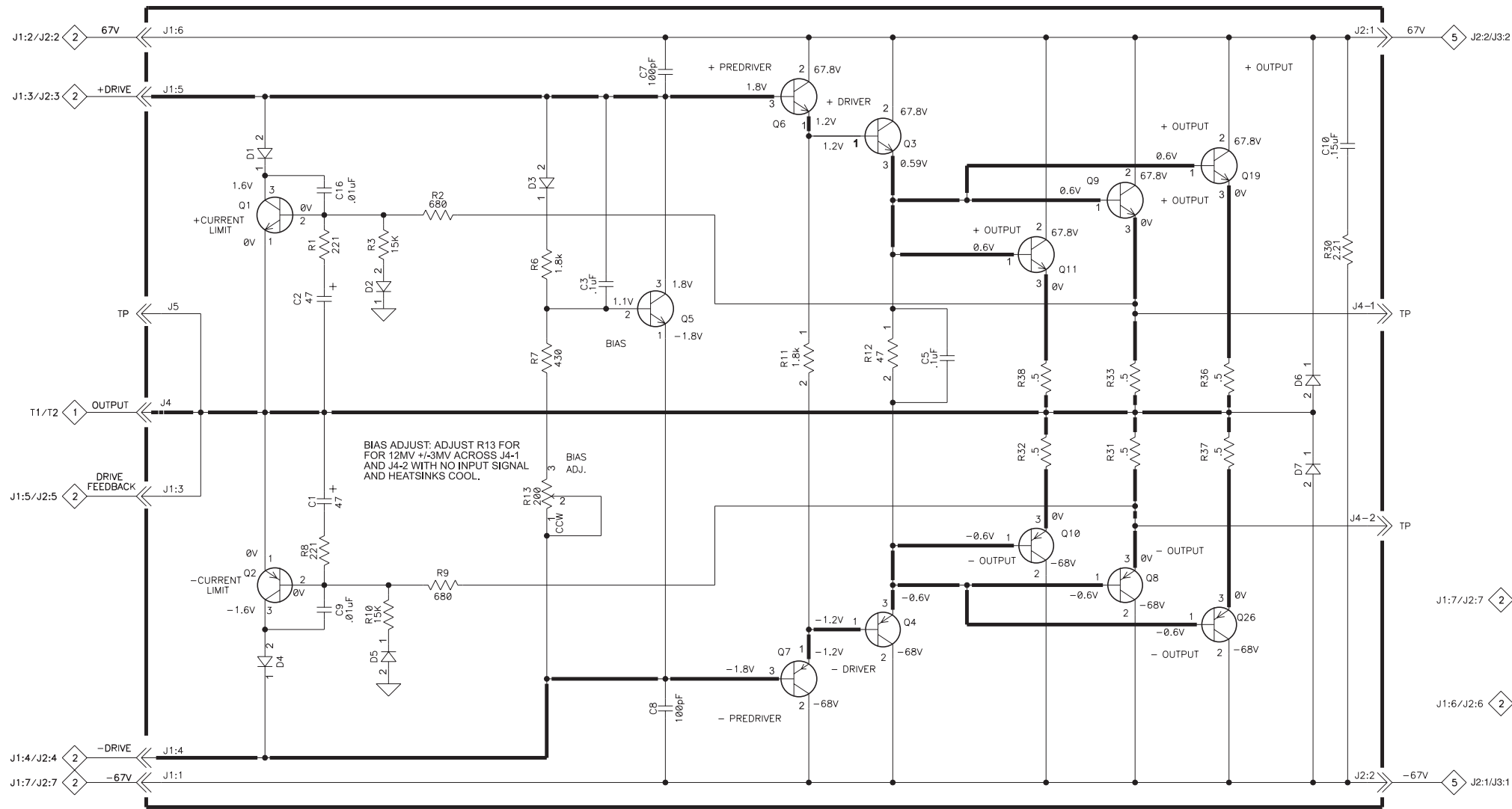

5 CAPACITOR 049653

! WARNING Parts located in the shaded area have critical characteristics. Use only replacement parts recommended by the manufacturer.

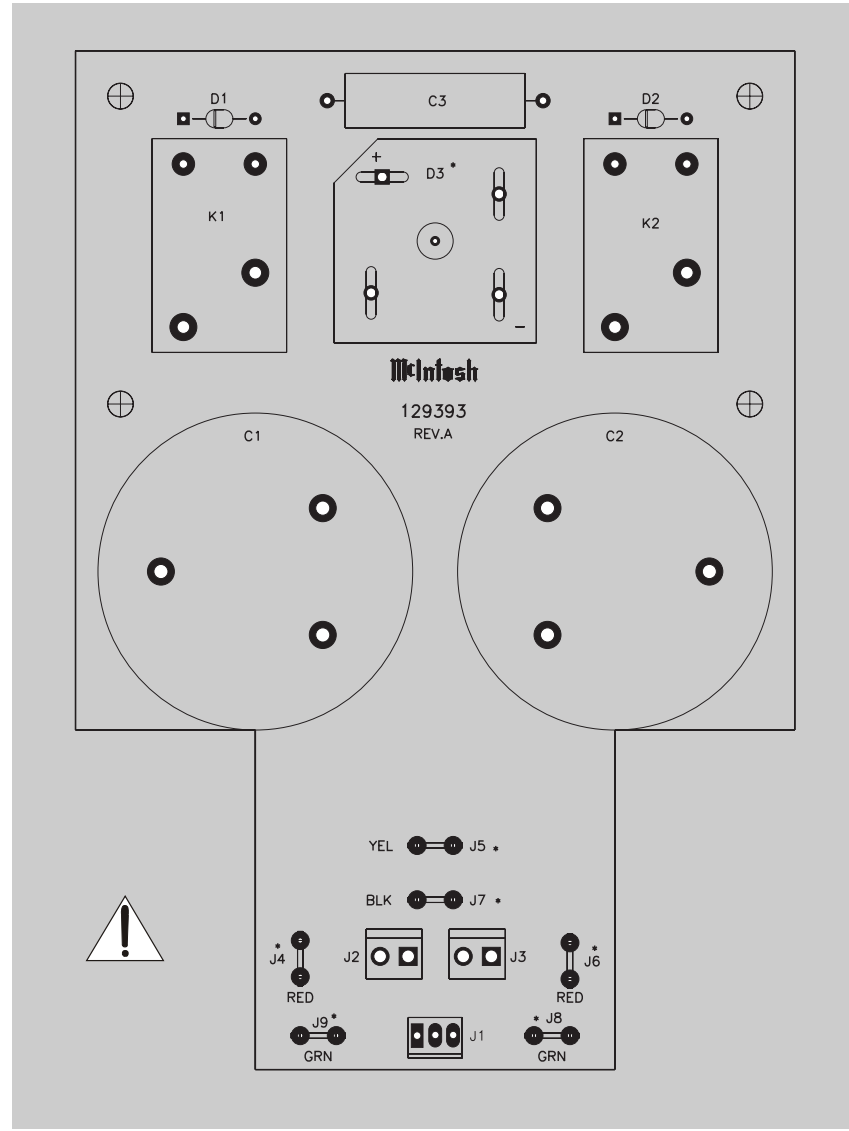
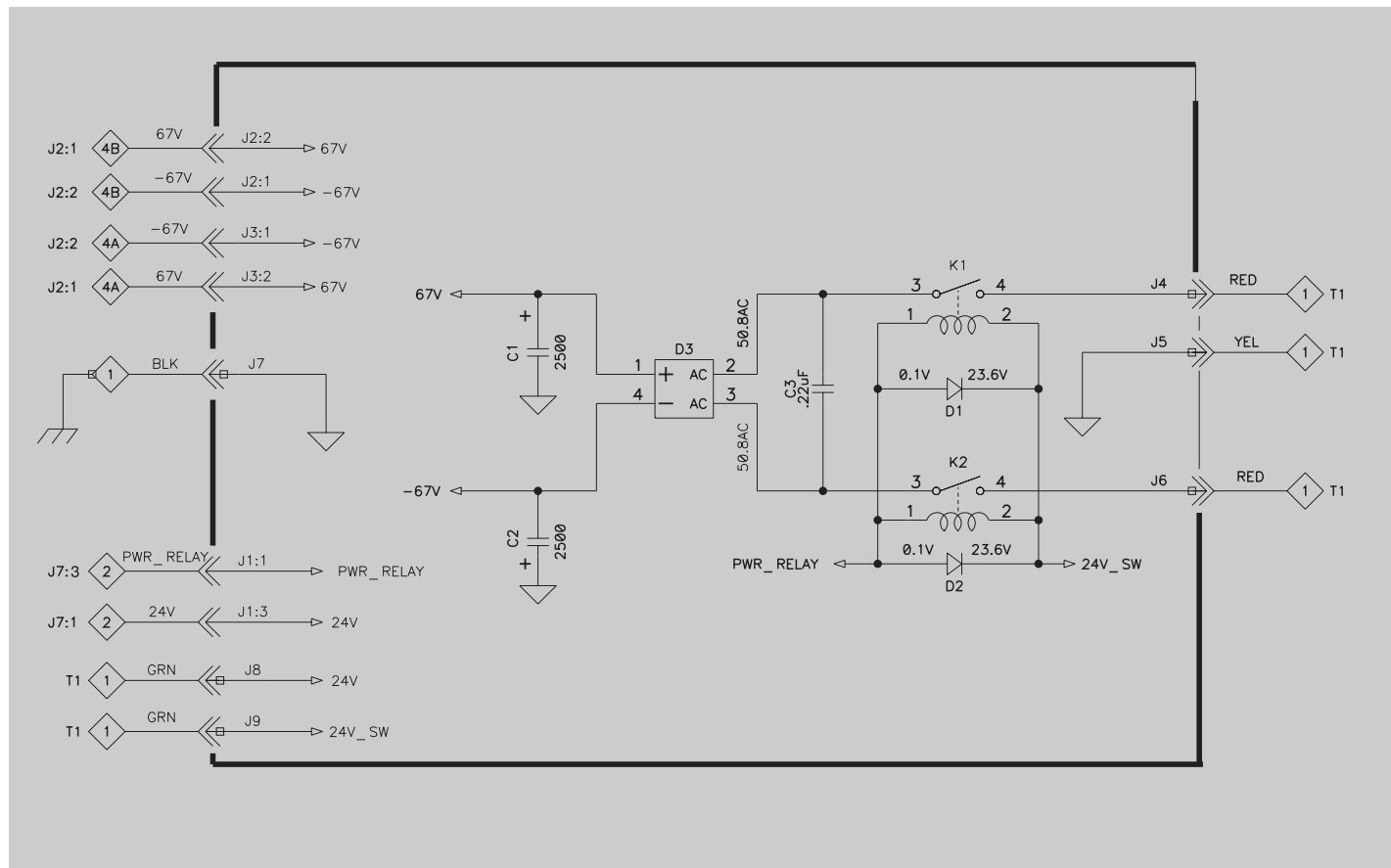

*DENOTES COMPONENTS ON REVERSE OR BACKSIDE OF PC BD

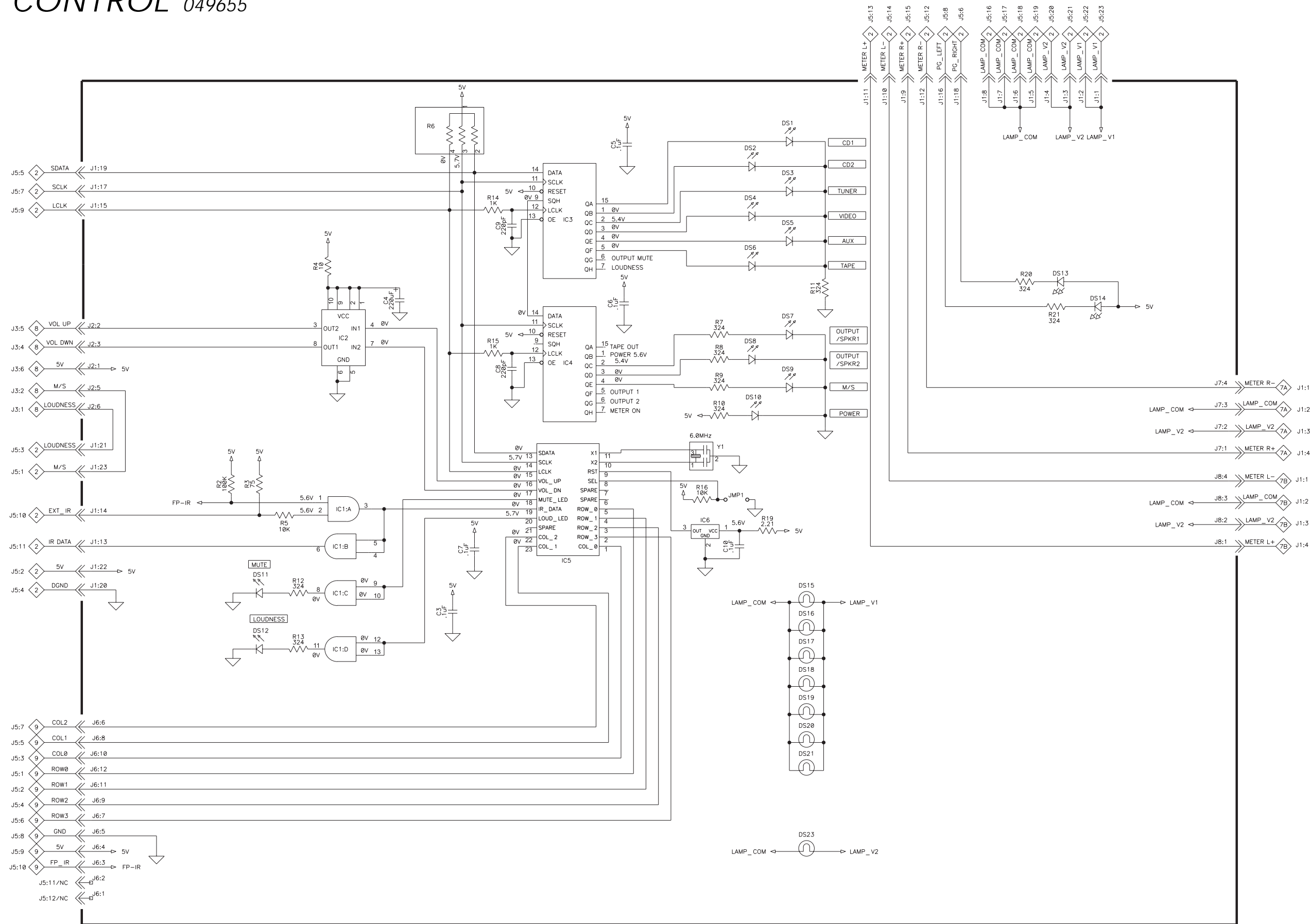

6 CONTROL PCB 049655

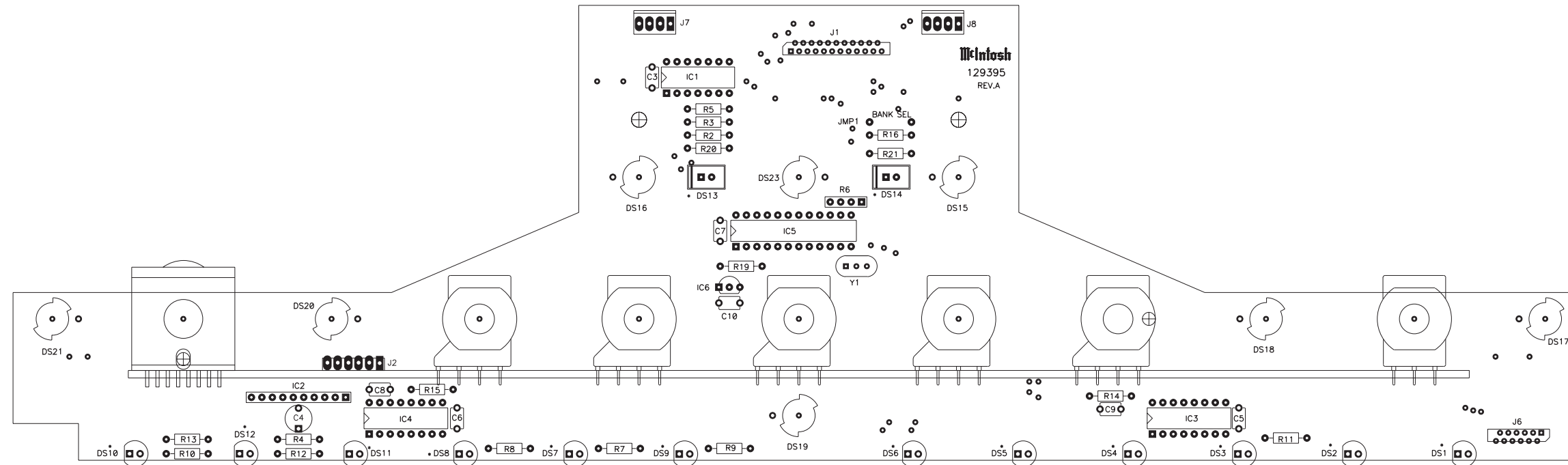

*DENOTES COMPONENTS ON REVERSE OR BACKSIDE OF PC BD

7A 7B LAMP 049235

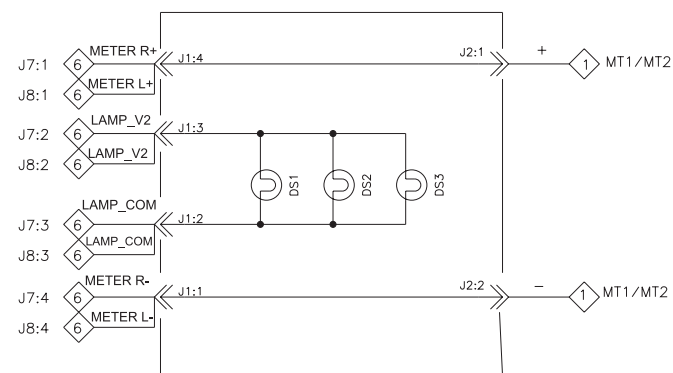

*DENOTES COMPONENTS ON REVERSE OR BACKSIDE OF PC BD

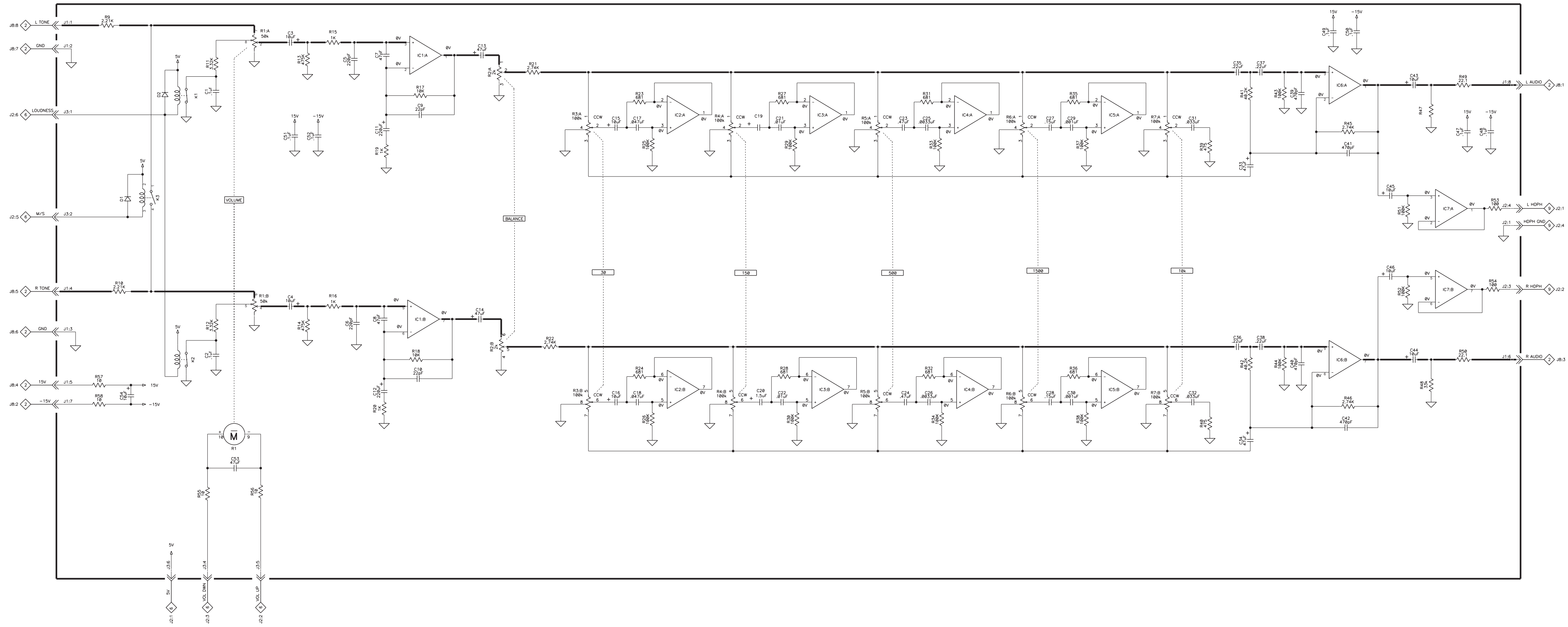

8 TONE 049656

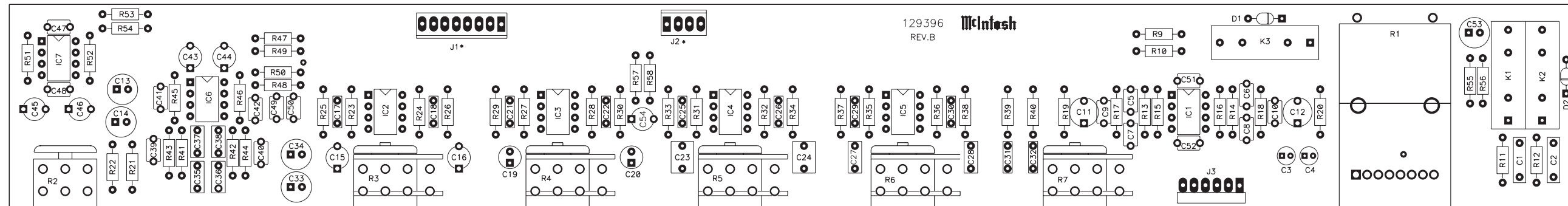

*DENOTES COMPONENTS ON REVERSE OR BACKSIDE OF PC BD

9 KEYBOARD 049696

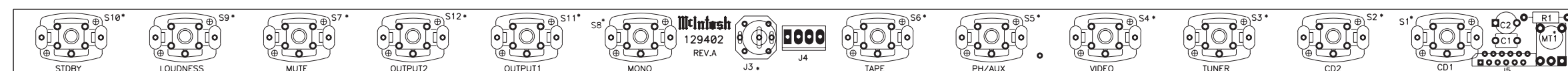
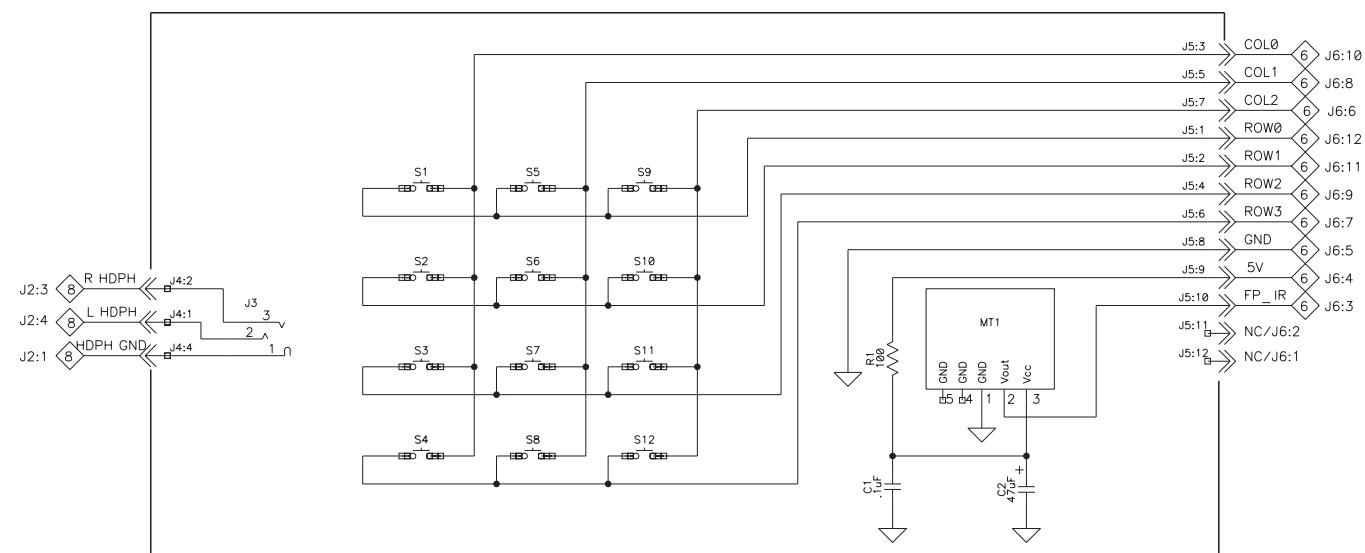

*DENOTES COMPONENTS ON REVERSE OR BACKSIDE OF PC BD

PARTS LIST

Reference No.	Description	Part No.		
Interconnect				
F1	FUSE	08910400	K1 K2 K3 K4 K5 K6 K7 K8 K9 K10 K11	RLY REED FORM 1A 5V 500OHMS
MT1 MT2	METER	12707700	K12 K13 K14 K15 K16 K17 K18	RLY REED FORM 1A 5V 500OHMS
RT1 RT2	THERMISTOR	05200800	K19	RELAY POWER TV5 24V
S1	SWITCH	14807300	LDR1 LDR2	LDR NETWORK VTL5C9
T1	POWER TRANSFORMER	04967600	Q1 Q2 Q3 Q4	TRANSISTOR N JFET
T2 T3	OUTPUT TRANSFORMER	04967500	Q5 Q6 Q7 Q8 Q19 Q20	TRANSISTOR NPN
TB1	TERMINAL BLOCK	07409100	Q9 Q10 Q11 Q12 Q13 Q14	TRANSISTOR PNP 120V
			Q15 Q16 Q27 Q28 Q29 Q30 Q37 Q38 Q48	TRANSISTOR PNP
			Q17 Q18 Q21 Q22 Q23 Q24 Q25 Q31 Q33	TRANSISTOR NPN 2K/REEL
			Q34 Q41 Q42 Q43 Q44 Q46 Q52 Q53	TRANSISTOR NPN 2K/REEL
			Q35 Q36	TRANSISTOR PNP 2SA32IC
			Q39 Q40	TRANSISTOR NPN 25C3334C
			Q45 Q47	TRANS POWER N-CHN ENHANCE
			Q49	IC REGULATOR +5V
			Q50	IC REGULATOR -15V
			Q51	IC REGULATOR 15V
			Q54	TRANS P CHAN JUNCTION FET
			R1 R2 R23 R24 R26 R61 R62 R91 R92	RES MF 10K 1% 1/4W
			R3 R4 R49 R50 R53 R54 R84 R171	RES MF 3.32K 1% 1/4W
			R5 R6 R15 R16	RES MF 475 1% 1/4W
			R7 R8 R93 R94	RES MF 10M 1% 1/4W
			R9 R10 R11 R12 R113 R114 R170	RES MF 47.5K 1% 1/4W
			R19 R20 R137 R141 R146 R147 R151	RES MF 1K 1% 1/4W
			R21 R22 R77 R78 R79 R80 R155	RES MF 100 1% 1/4W
			R25	RES MF 165K 1% 1/4W
			R27	RES MF 68.1K 1% 1/4W
			R29 R30 R63 64 R101 R102	RES MF 4.75K 1% 1/4W
			R35 R36 R37 R38	RES MF 806 1% 1/4W
			R39 R40 R59 R60	RES MF 187K 1% 1/4W
			R41 R42 R43 R44 R45 R46 R47 R48 R132	RES MF 221 1% 1/4W
			R51 R52 R55 R56 R57 R58 R65 R66	RES MF 324 OHM 1% 1/4W
			R67 R68	RES 1.8 OHM 2W 5% WW FP
			R69 R70	RES WW 2.7 OHM 2W 5% FP
			R71 R72	RES MF 27.4K 1% 1/4W
			R73 R74 R75 R76	RES FP 47 OHM 5% 1/4W
			R81 R83 R166 R167	RES MF 12.1K 1% 1/4W
			R82 R87	RES MF 2.1K 1% 1/4W
			R85	RES MF 20K 1% 1/4W
			R86 R89 R90 R111 R129 R145	RES MF 100K 1% 1/4W
			R95 R96	RES MF 274K 1% 1/4W
			R97 R98	POT TRIM 100K OHM
			R99 R100	RES MF 2.21M 1/4W
			R103 R104 R105 R106	RES MF 11K 1% 1/4W
			R107 R108 R109 R110	RES MF 5.62K OHM 1% 1/4W
			R112 R125 R126 R127 R128 R130 R131	RES NETWORK 2X220K ISO
			R115 R116	RES MF 47.5 1% 1/4W
			R117 R118	RES MF 95.3K 1% 1/4W
			R119 R120 R172	RES MF 7.5K 1% 1/4W
			R121 R122	RES MF 95.3 1% 1/4W
			R123 R124	RES MF 2.21 OHM 1/4W 1%
			R13 R14 R17 R18 R31 R32 R33 R34	RES MF 267K 1% 1/4W
			R133 R134 R135 R138 R139	RES MF 221 1% 1/4W
			R136 R140	RES NET 2 X 22K ISOLATED
			R142 R143	RES MF 30.1K 1% 1/4W
			R144 R148	RES NETWORK 2X220K ISO
			R149 R150	RES MF 22.1 1% 1/4W
			R152 R153	RES MF 1K 1% 1/4W
			R154	RES NETWORK 8X100 ISO
			R156 R157 R158 R159 R160 R161 R162	RES MF 182 1/4W 1%
			R163	RES MF 182 1/4W 1%
			R164 R165	RES MF 178K 1% 1/4W
			R168	RES MF 3.65K 1% 1/4W
			R169	RES MF 3.16K 1% 1/4W
			R173	RES MF 5.11K 1% 1/4W
			S1	SWITCH SLIDE
			SP1 SP2	BRACKET PCB CARD MOUNTING
				08705000
				08705000
				08706900
				14417900
				13222200
				13225400
				13225500
				13222400
				13222300
				13222300
				13228600
				13228500
				13224200
				13310800
				13315300
				13315400
				13222600
				14405300
				14409500
				14408600
				14426400
				14410800
				14409000
				14419600
				14411600
				14408100
				14409700
				14408900
				14440600
				14417200
				14433800
				13923000
				13921800
				14414100
				13704200
				14415400
				14429900
				14410400
				14411300
				14444100
				13450200
				14426500
				14410100
				14444700
				14426200
				14444200
				14412700
				14421000
				14422000
				14437800
				14411800
				14417200
				14436600
				14422500
				14426200
				14416000
				14409000
				14427500
				14427300
				14427300
				14442000
				14418900
				14419900
				14408300
				14805900
				00361100

PARTS LIST con't

Reference No.	Description	Part No.
049665 HEATSINK PCB		
C1 C2	CAP ELECT 47UF 35V	06644600
C3 C5	CAP MONO .1UF 50V 20% Z5U	06130500
C7 C8	CAP MONO 100PF 100V 10% NPO	06130000
C9 C16	CAP MONO .01UF 50V 20% X7R	06130400
C10	CAP POLYPROP 0.15UF 10% 250VDC	06436300
D1 D2 D3 D4 D5	DIODE SILICON	07004700
D6 D7	DIODE 200V 6A	07013300
J1-	CONN MALE 7 PIN	11721700
J2-	CONN HEADER 2 PIN 0.156	11740400
J4	BLADE FASTON W/FEET	11770800
J4-	CONN MALE 2 PIN	11721300
Q1	TRANSISTOR NPN SILICON	13217100
Q2	TRANSISTOR PNP SILICON	13217200
Q6	TRANSISTOR NPN	13226200
Q7	TRANSISTOR PNP	13226100
R1 R8	RES MF 221 1% 1/4W	14417200
R2 R9	RES MET OX 680 5% .5W	13709300
R3 R10	RES MF 15K 1% 1/4W	14441200
R6 R11	RES MET OX 1.8K 5% .5W	13709400
R7	RES MET OX 430 5% .5W	13709500
R12	RES MET OX 47 5% .5W	13709600
R13	POT TRIM 200 OHM 20% HORIZ AD	13439000
R30	RES MF 2.21 OHM 1/4W 1%	14437800
R31 R32 R33 R36 R37 R38	RES WW .5 OHM 5W 5%	13917700
RT1	SENSOR THERMAL	14424900
049653 CAPACITOR PCB		
C1 C2	CAP ELECT 25000UF 75V	06650400
C3	CAP M POLY .22UF 20% 400VDC	06426700
D1 D2	DIODE SILICON	07004700
D3	DIODE BRIDGE RECTIFIER	07013900
J1	CONN MALE 3 POS MTS100 NORMAL	11721400
J2 J3	CONN HEADER 2 PIN 0.156	11740400
J4 J5 J6 J7 J8 J9	BLADE FASTON W/FEET	11770800
K1 K2	RELAY 24V TV8/VDE CERTIFIED	08707200
049655 CONTROL PCB		
C3 C5 C6 C7 C10	CAP MONO .1UF 50V 20% Z5U	06130500
C4	CAP ELECT 220UF 25V	06650700
C8 C9	CAP MONO 220PF 100V 10% NPO	06130100
DS1 DS2 DS3 DS4 DS5 DS6 DS7 DS8 DS9	LED LAMP RED	07009300
DS10 DS11 DS12	LED LAMP RED	07009300
DS13 DS14	LED AMBER	05813300
DS15 DS16 DS17 DS18 DS19 DS20	LAMP INCANDESCENT 14V 100MA	05815300
DS21 DS23	LAMP INCANDESCENT 14V 100MA	05815300
IC1	IC AND 2 INPUT X 4	13317500
IC2	IC DC MOTOR DRIVER	13319100
IC3 IC4	IC SHFT REG SER-PAR	13318600
IC5	IC PROGRAMMED	13343800
IC5	SOCKET IC 24-PIN	17813900
IC6	IC MICRO RESET POS	13324100
J1	CONN 23PIN FFC	11771500
J6	CONN 12 PIN FFC	11772000
J7 J8	CONN 4 PIN	11721500
R2	RES MF 100K 1% 1/4W	14411300
R3	RES MF 75 OHM 1% 1/4W	14444400
R4	RES MF 10 1% 1/4W	14415700
R5 R16	RES MF 10K 1% 1/4W	14405300
R6	RES NETWORK 3X10K BUSSED	14429000
R7 R8 R9 R10 R11 R12 R13 R20 R21	RES MF 324 OHM 1% 1/4W	14433800

R14 R15	RES MF 1K 1% 1/4W	14409000
R19	RES MF 2.21 OHM 1/4W 1%	14437800
Y1	RESONATOR CERAMIC 6.0MHZ W/CAP	18003900
049235 LAMP PCB		
DS1 DS2 DS3	LAMP 14V #7373	05812000
J1	4 PIN RT. ANGLE	11724000
J2	CONN. 2 POS. R-ANGLE	11727400
049656 TONE PCB		
C1 C2	CAP M POLY .1UF 10% 100VDC	06425400
C3 C4	CAP ELECT 10UF 16V (4X5 CASE)	06638200
C5 C6	CAP MONO 220PF 100V 10% NPO	06130100
C7 C8	CAP MONO 47PF 200V 10% NPO	06129900
C9 C10	CAP MONO 22PF 200V 10% NPO	06129800
C11 C12	CAP ELECT 220UF 25V	06650700
C13 C14 C33 C34	CAP ELECT 47UF 50V	06621500
C15 C16 C43 C44 C45 C46 C54	CAP ELECT 10UF 50V	06644500
C17 C18	CAP M POLY .047UF 5% 63VDC	06432000
C19 C20	CAP ELECT 1.5UF 10% 50V	06627100
C21 C22	CAP M POLY .01UF 5% 63VDC	06431200
C23 C24	CAP M POLY .47UF 5% 50/63VDC	06433300
C25 C26	CAP MPOLY .0033UF 5% 63VDC	06430600
C27 C28	CAP M POLY .15UF 5% 63VDC	06432700
C29 C30	CAP POLY 0.001MF 5% 63VDC	06430000
C31 C32	CAP M POLY .033UF 5% 63VDC	06431800
C35 C36 C37 C38	CAP M POLY .22UF 5% 63VDC	06432900
C39 C40 C41 C42	CAP MONO 470PF 100V 10% NPO	06130200
C47 C48 C49 C50 C51 C52	CAP MONO .1UF 50V 20% Z5U	06130500
C53	CAP ELECT 47UF 10V BP	06637800
D1 D2	DIODE SILICON	07004700
IC1 IC6 IC7	IC DUAL OPERATIONAL AMPLIFIER	13326000
IC2 IC3 IC4 IC5	IC OPERATIONAL AMPLIFIER	13302800
J1	CONN 8 POS MALE FRICTION LOCK	11727500
J2	CONN 4 PIN	11721500
J3	CONN MALE 6 POS RT ANGLE	11770700
K1 K2 K3	RELAY REED FORM 1A 5V 500 OHMS	08705000
R1	POT 50KAX2	13449000
R2	POT BALANCE 2KOHM	13446400
R3 R4 R5 R6 R7	POT EQUAL	13445700
R9 R10	RES MF 2.21K 1% 1/4W	14429800
R11 R12	RES MF 3.32K 1% 1/4W	14409500
R13 R14	RES MF 475K 1% 1/4W	14436400
R15 R16 R19 R20	RES MF 1K 1% 1/4W	14409000
R17 R18	RES MF 10K 1% 1/4W	14405300
R21 R22 R45 R46	RES MF 2.74K 1% 1/4W	14430400
R23 R24 R27 R28 R31 R32 R35 R36	RES MF 681 1% 1/4W	14419500
R25 R26R29 R30 R33 R34 R37 R38 R43	RES MF 100K 1% 1/4W	14411300
R39 R40	RES MF 475 1% 1/4W	14408600
R41 R42	RES MF 40.2K 1% 1/4W	14410700
R44 R51 R52	RES MF 100K 1% 1/4W	14411300
R47 R48	RES MF 33.2K 1% 1/4W	14401500
R49 R50	RES MF 22.1 1% 1/4W	14416000
R53 R54	RES MF 100 1% 1/4W	14419600
R55 R56 R57 R58	RES MF 10 1% 1/4W	14415700
049696 KEYBOARD PCB		
C1	CAP MONO .1UF 50V 20% Z5U	06130500
C2	CAP ELECT 47UF 35V	06644600
J3	JACK PHONO 1/8 STEREO VER	11746200
J4	CONN 4 PIN	11721500
J5	CONN 12 PIN FFC	11772000
MT1	GASKET SENSOR	09437700
MT1	RECEIVER IR	12104100
R1	RES MF 100 1% 1/4W	14419600
S1 S2 S3 S4 S5 S6 S7 S8 S9 S10 S11 S12	SWITCH TACT	15005800

EXPLODED VIEW

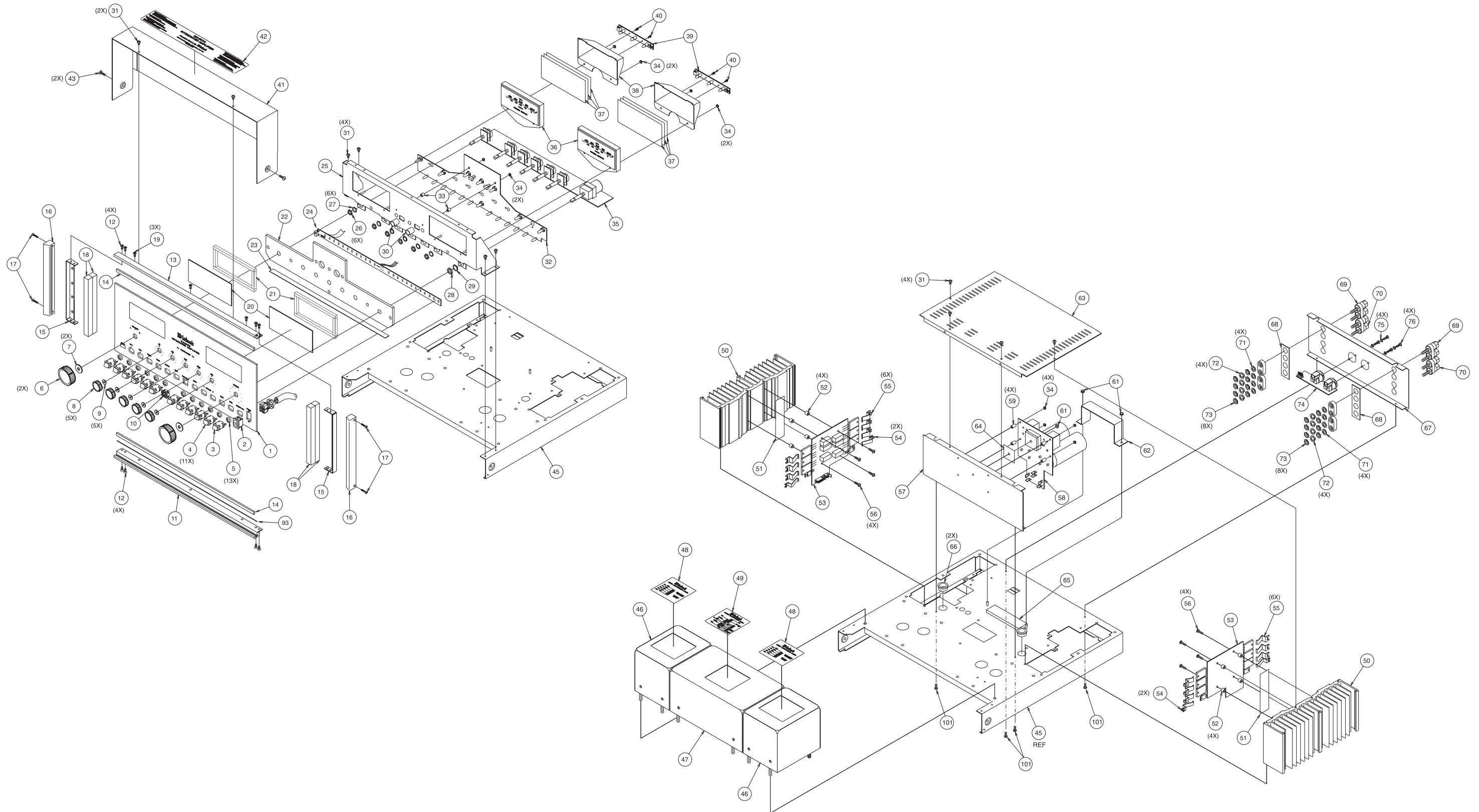

EXPLODED VIEW

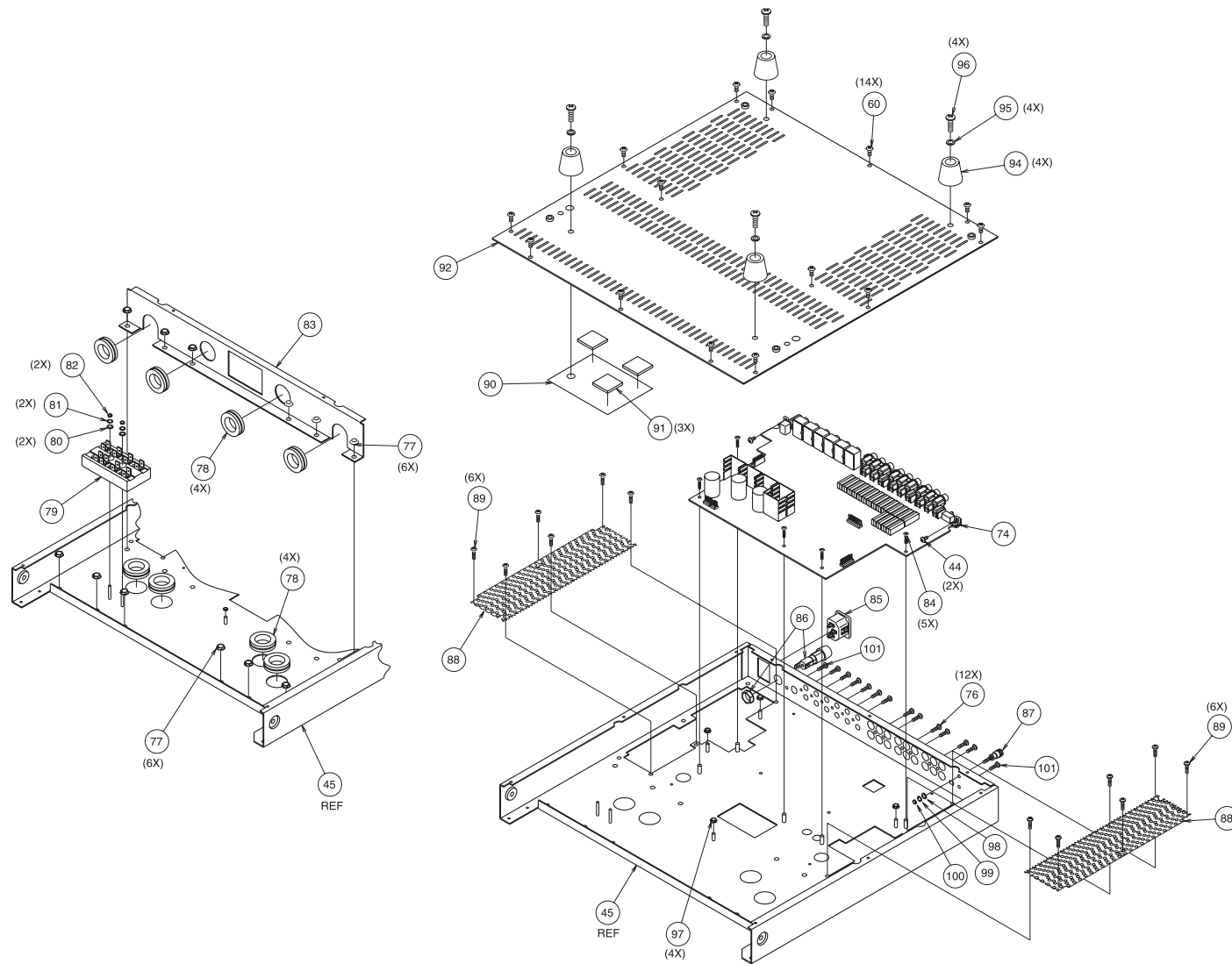

EXPLODED PARTS LIST

Item No.	Part No.	Description
1	016456	GLASS
2	148073	INPUT POWER SWITCH
3	017531	PUSHBUTTON ASSY RED
4	017517	PUSHBUTTON ASSY BLK
5	078033	O-RING
6	749695	KNOB ASSY
7	104017	WASHER FELT BLK 3/4 X 1/4 X 1/16
8	749694	KNOB ASSY
9	104073	WASHER FELT 1/4 X 5/8 MPI-4
10	017854	BEZEL HEADPHONE
11	018707	BOTTOM EXTRUSION
12	400149	SCREW MACH 6-32 X 1/4 FL U/H ST
13	018738	TOP EXTRUSION
14	094016	TAPE FOAM 1/4 X 1/8
15	004899	BRACKET EXTRUSION
16	018612	ENDCAP 7"
17	401042	SCREW TS 4-40 X 1/2 SLOT FILLISTER
18	094360	TAPE FOAM 1/2 X 1/2
19	401172	SCREW TC 6-32 X 1/4 PH FL U/C
20	017363	PLEXIGLAS FILTER LT BLUE
21	094017	TAPE FOAM 1/4 X 1/4
22	017864	PLEXI MA6900
23	022314	FISHPAPER SHIELD
24	749696	KEYBOARD PCB ASSY
25	005475	SUBPANEL
26	410004	NUT CONTROL M7 X 0.75 HEX
27	404013	WASHER LOCK 5/16 X .435 X .002
28	410002	NUT 5 CONTROL M9 X 0.75
29	404014	WASHER LOCK 3/8 X .507 X .002 INT STAR
30	077032	SLEEVING FIBERGLASS 7/16
31	401054	SCREW TAPTITE 6-32 X 1/4 PH PAN BLK
32	750510	CONTROL PCB ASSY
33	021165	SPACER 4 X 1/4
34	402001	KEP NUT 4-40 CADMIUM PLATE
35	749656	TONE PCB ASSY
36	124092	METER
37	092342	FILTER PALE BLUE
38	017447	LIGHT BOX PLASTIC
39	749235	LAMP PCB ASSY
40	114072	RIVET NYLON POP-IN
41	005714	DUST COVER
42	126819	TOP COVER DECAL
43	400287	SCREW MACH 8-32 X 3/8 PH TRUSS HD
44	400250	SCREW MACH SEMS 6-32 X 1/4 PH PAN
45	005702	CHASSIS
46	749675	OUTPUT TRANSFORMER
47	749676	POWER TRANSFORMER
48	166128	DECAL OUTPUT TRANSFORMER
49	166129	DECAL POWER TRANSFORMER
50	018691	HEATSINK
51	084194	ISOSTRATE
52	112087	SPACER PCB 1/4
53	749665	HEATSINK PCB ASSY
54	414118	CLIP TRANSISTOR 218
55	414119	CLIP TRANSISTOR 214
56	401059	SCREW SM 6 X 5/8 PH PAN TYPE A
57	005188	SUBREAR PANEL
58	749653	CAPACITOR PCB ASSY
59	412060	SPACER #4 X 5/16 STEEL
60	401078	SCREW TAP 8-32 X 5/16 PH PAN
61	402003	NUT MACH 6-32 W/LOCK
62	005202	STRAP
63	005185	TOP COVER
64	084135	THERMAL PAD
65	094401	TAPE FOAM 1/4 X 1 3M #4504
66	078034	GROMMET
67	005453	REAR PANEL
68	004800	PLATE OUTPUT
69	084189	BINDING POST DUAL RED-RED
70	084124	BINDING POST DUAL
71	104148	WASHER FLAT BRASS
72	104130	WASHER LOCK #10 SLIT PHOS/BRNZ
73	110009	NUT M5 X 0.8 BRASS W/GOLD PLATE
74	750156	MAIN PCB ASSY
75	404142	WASHER LOCK 2.5mm INT STAR ZINC
76	101197	SCREW HI/LO 4-24 X 3/8 PH RD BLK
77	102006	NUT MACH 10-32 W/LOCK
78	078025	GROMMET RUBBER 3/4
79	074091	TERMINAL BLOCK AC
80	404001	WASHER FLAT STEEL 4 X 9/32 X .025
81	404004	WASHER LOCK 5 X .255 INT STAR
82	402022	NUT MACH 4-40 X 3/16 X 1/16
83	005194	BRACKET CHASSIS SUPPORT
84	400256	SEMS MS 4-40 X 3/8 CCA PAN
85	117487	RECEPTACLE AC LINE
86	178161	HOLDER FUSE 5 X 20mm IEC
87	084217	GROUND POST GOLD
88	005401	HEATSINK VENT
89	401250	SCREW TT 6-32 X 1/2 PH PAN
90	017869	SHIELD
91	094332	TAPE MTG DBL COATED 1/8 THK
92	005634	BOTTOM COVER
93	404072	CORD DIAL .027
94	017218	FOOT BLACK PLASTIC
95	404080	WASHER FLAT #10 CLEAR ZINC
96	400159	SCREW MACH 10-32 X 3/4 PH PAN
97	402020	NUT MACH 6-32 SELF LOCK
98	104072	WASHER 1/4 IDX .408 X .18
99	104078	WASHER LOCK #8 STAR
100	410014	NUT 4 X .7
101	101222	SCREW TT SEMS 6-32 X 1/4

REPACKING INSTRUCTIONS

In the event it is necessary to repack the unit for shipment, the unit must be packed exactly as shown below.

IMPORTANT - The four plastic feet must be attached to the bottom of the unit so they will locate in the four holes of the bottom pad. Two #10 x 2-1/4" screws and washers must be used to fasten the unit securely to the bottom pad and wood skid. Failure to do this will result in shipping damage.

If a shipping carton or any of the interior parts is needed, please call or write the Customer Service Department of McIntosh Laboratory. Order parts from the accompanying list by part number.

Use the original shipping carton and interior parts only if they are in good serviceable condition.

Qty.	Part No.	Description
1	033888	Shipping carton only
4	033887	End cap (Foam pad)
1	033697	Inside carton only
1	033725	Top pad
1	034194	Bottom pad
2	017218	Plastic foot (spacer)
1	033699	Wood skid
2	101204	#10 x 2-1/4" Wood screw
2	104033	#10 x 1-3/4" Flat washer
4	017218	Plastic foot
4	100159	#10-32 x 3/4" Machine screw
4	104080	#10 x 7/16" Flat washer

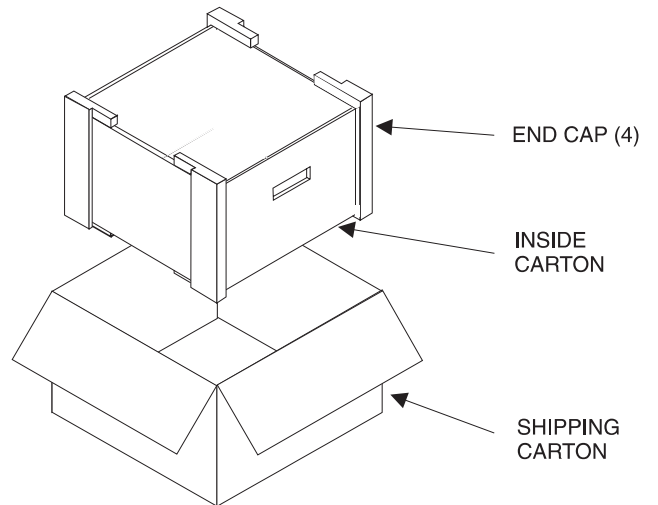
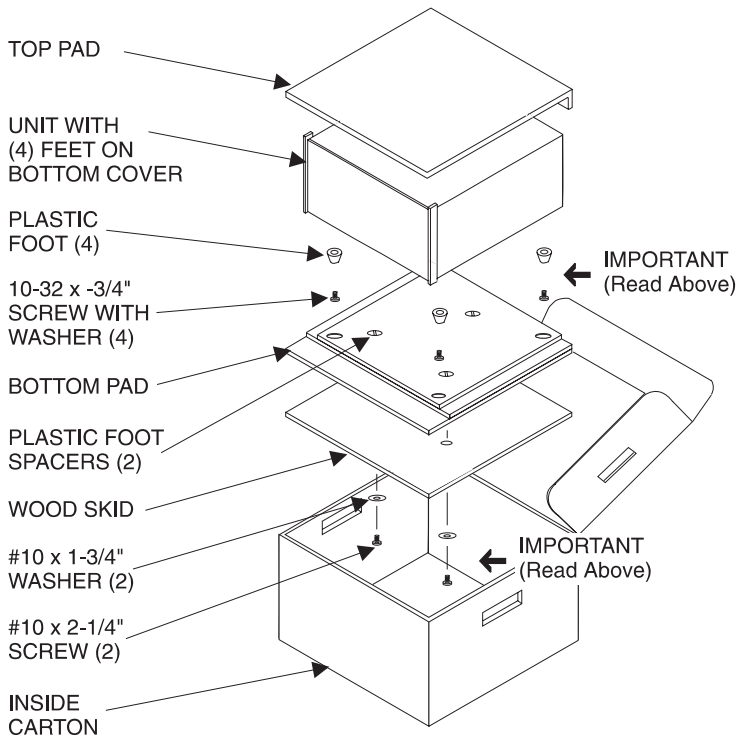

MA6900

INTEGRATED AMPLIFIER

SERVICE MANUAL

The continuous improvement of its products is the policy of McIntosh Laboratory Incorporated, who reserve the right to improve design without notice. Because of the constant upgrading of McIntosh products' circuitry and components, the Company cannot insure, and does not warrant, the accuracy of the within schematic material, which is intended for information only.