

MC2000

POWER AMPLIFIER

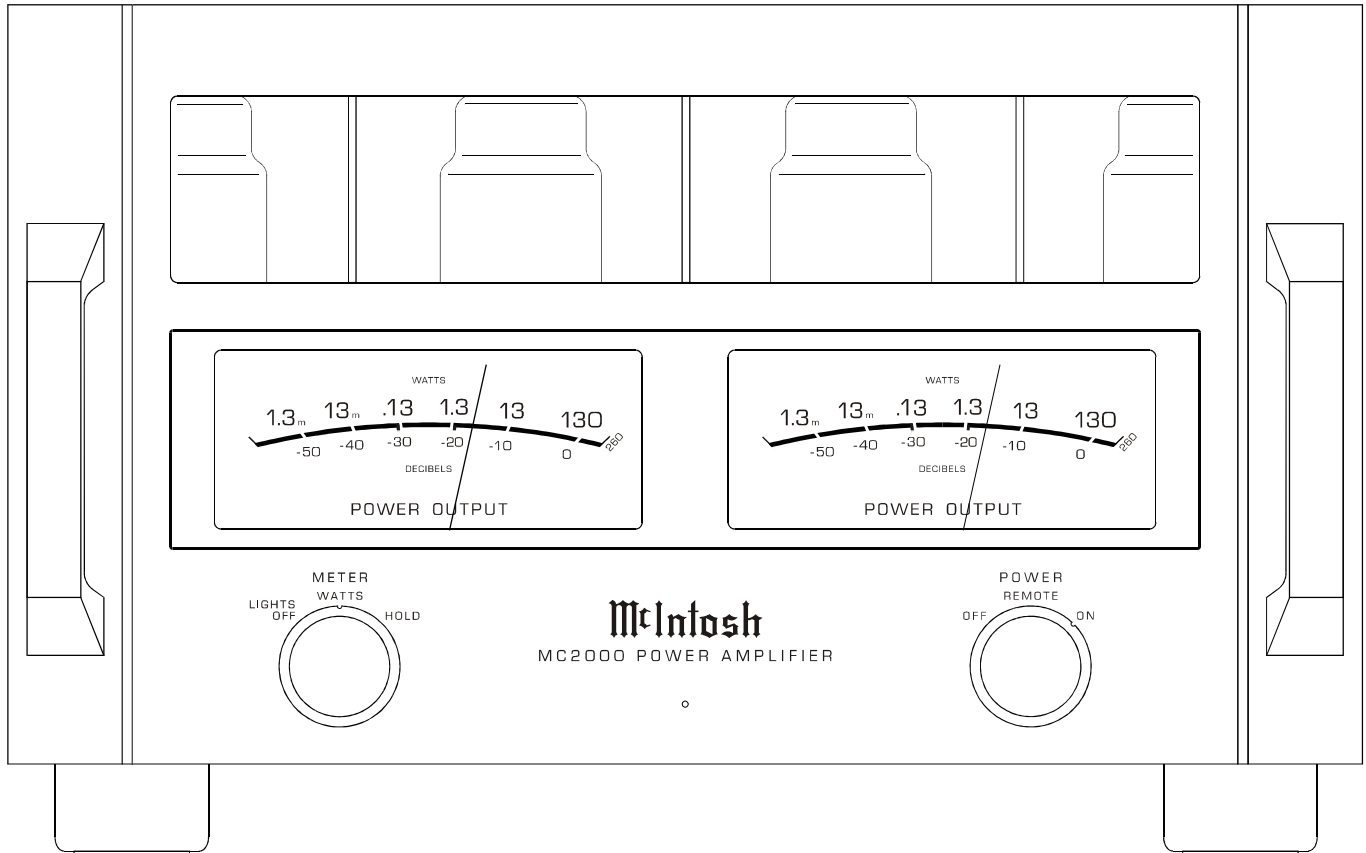

CONTENTS

Performance Specifications	2	Switch Remote PCB and Schematic	17 - 18
Notes	2	Meter PCB and Schematic	19 - 20
Rear Panel	3	Bias Control PCB and Schematic	21 - 22
Section Location	4	Meter Lamp PCB and Schematic	21 - 22
Block Diagram	5 - 6	Lamp PCB and Schematic	21 - 22
Interconnection Diagram	7 - 8	Logo Lamp PCB and Schematic	21 - 22
Input PCB and Schematic	9 - 10	Output PCB and Schematic	21 - 22
Main PCB and Schematic	11 - 13	Parts List	23 - 24
Power Supply PCB and Schematic	14	Exploded View and Parts List	25 - 28
AC Power PCB and Schematic	15 - 16	Repacking Instructions	29

McIntosh

SERVICE MANUAL

PERFORMANCE SPECIFICATIONS

Power Output

130 watts into 8, 4 or 2 ohm loads is the minimum sine wave continuous average power output per channel from 20Hz to 20,000Hz with both channels operating.

Total Harmonic Distortion

0.5% maximum harmonic distortion at any power level from 250 milliwatts to rated power per channel from 20Hz to 20,000Hz with both channels operating.

Intermodulation Distortion

0.5% maximum intermodulation distortion if instantaneous peak power output does not exceed twice the output rating per channel with both channels operating, for any combination of frequencies from 20Hz to 20,000Hz.

Rated Power Band

20Hz to 20,000Hz

Frequency Response (at 1 watt)

+0, -0.25dB from 20Hz to 20,000Hz
+0, -3dB from 10Hz to 100,000Hz

Hum and Noise (A-Weighted)

100dB below rated output

Damping Factor

Greater than 18

Output Load Impedance

2, 4 or 8 ohms

Input Impedance

20k ohms Unbalanced (RCA Phono Jacks)
40k ohms Balanced (XLR Connectors)

Input Sensitivity (Switch Selectable)

2.5 volts for rated output
1.2 volts for rated output (1 volt for 100 watts output)

Tube Compliment

8 – KT88 or 6550 Output Tubes
4 – 12AX7A Input Tubes
2 – 12AT7 Driver Tubes

Power Requirement

100 Volts, 50/60Hz at 5.8 Amps
120 Volts, 50/60Hz at 4.8 Amps
230 Volts, 50/60Hz at 2.5 Amps

Note: Refer to the rear panel of the MC2000 for the correct voltage.

Dimensions

17-3/4 inches (45.1cm) wide by 11 inches (27.9cm) high. Depth behind front panel is 18-3/4 inches (47.6 cm). Handle clearance required in front of the mounting panel is 1-5/8 inches (4.1 cm).

Finish

Stainless Steel Chassis with Titanium Gold Super Mirror Finish, Black Transformer Enclosures, Black Base, Glass Front Panel with gold plated Handles and Knobs

Weight

Amplifier - 135 pounds (61.2 kg) net, 144 pounds (65.3 kg) in shipping carton
Accessories - 18 pounds (8.2 kg) in shipping carton

NOTES

1. The heavy lines on the schematics denote the primary signal path.
2. Unless otherwise noted, all voltages indicated on the schematics are measured under the following conditions:
 - a. AC input at 120 volts, 50/60Hz
 - b. All voltages are +/-10% with respect to ground. A high impedance (10megaohm) voltmeter must be used.
3. Unless otherwise specified:
 - a. Resistors values are in ohms.
 - b. Capacitor values are in microfarads (uF).
 - c. Inductor values are in microhenries (uH).
4. On PC Board Drawings, Square Pad Indicates:
 - a. Polarized Capacitors - Positive
 - b. Diode - Cathode
 - c. Others - Pin 1
5. **WARNING:** Parts marked with the symbol  have critical characteristics. Use only replacement parts recommended by the manufacturer.

REAR PANEL

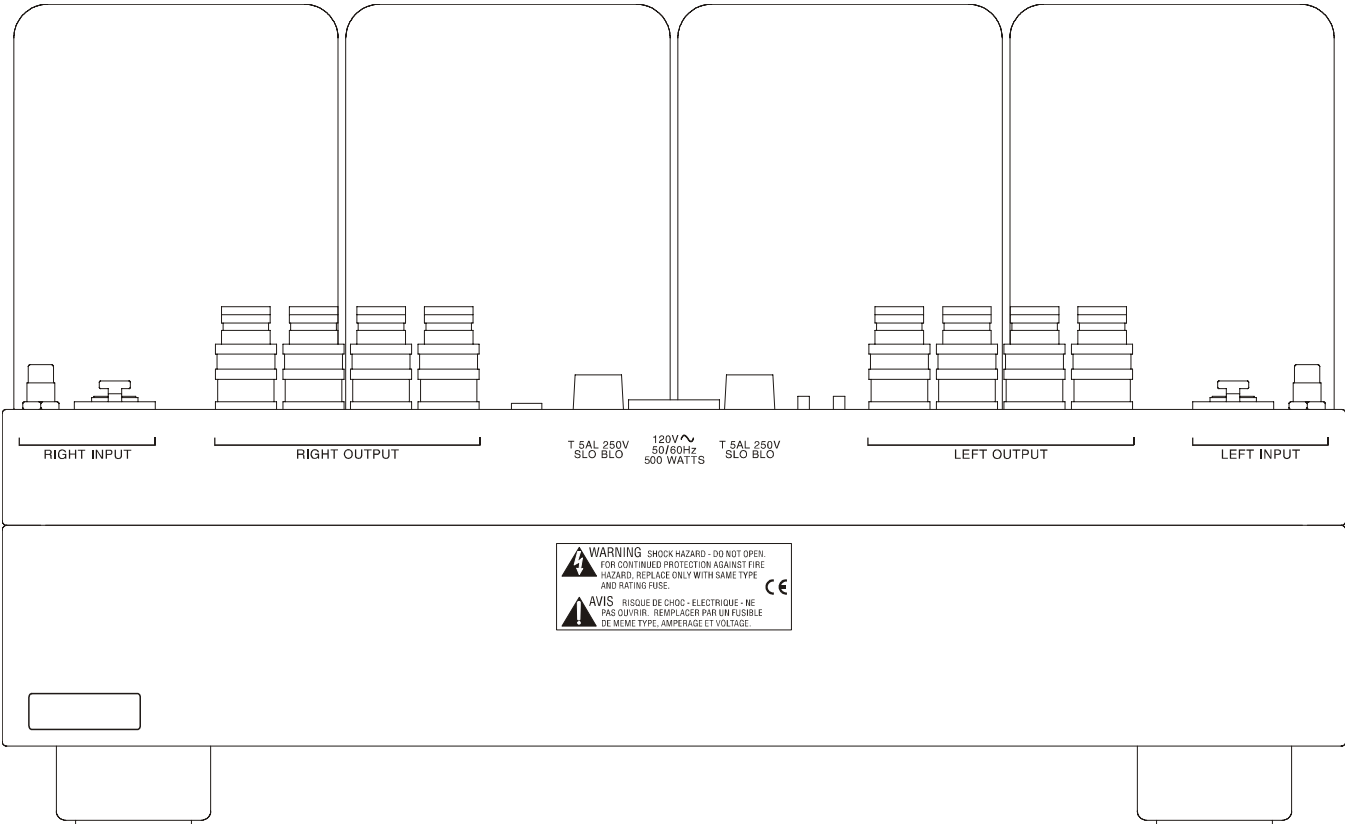

SECTION LOCATION

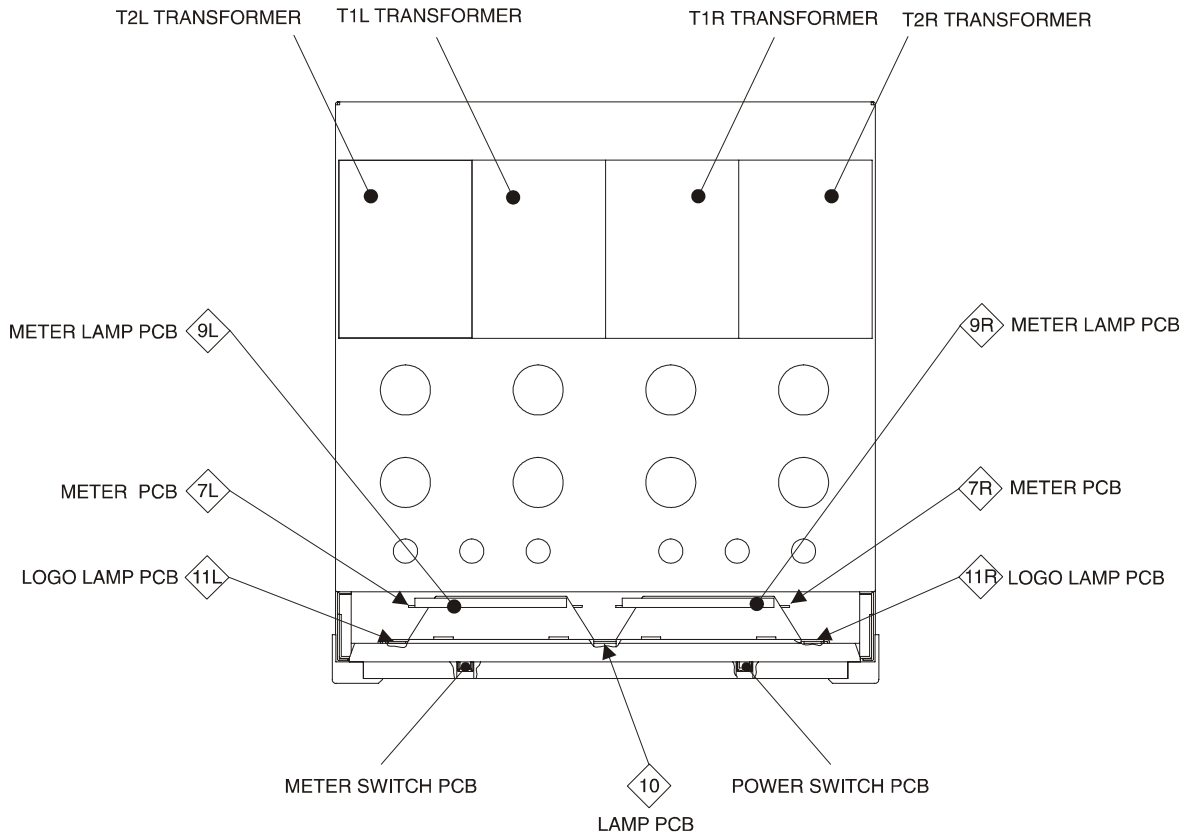

TOP VIEW WITH COVER REMOVED

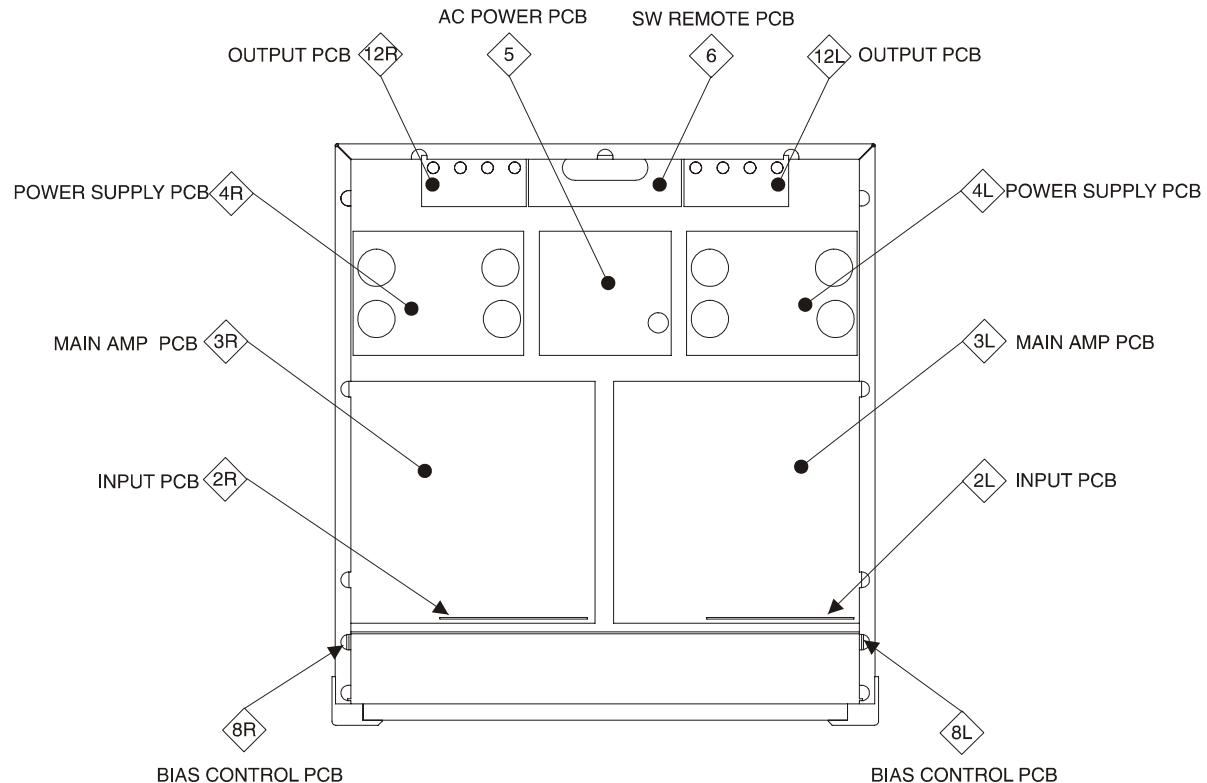

BOTTOM VIEW WITH COVER REMOVED

BLOCK DIAGRAM

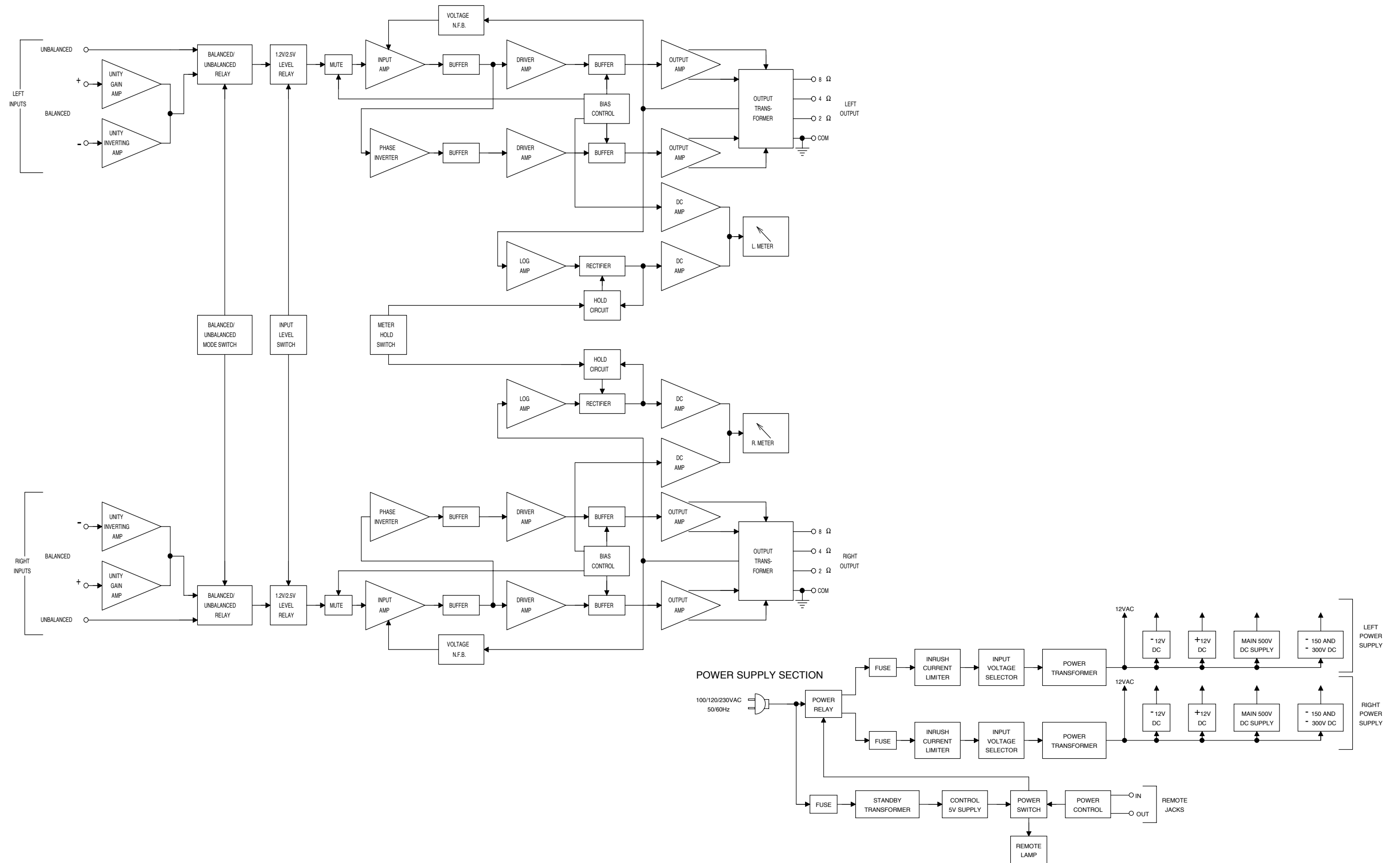

INTERCONNECT

! WARNING Parts located in the shaded area have critical characteristics. Use only replacement parts recommended by the manufacturer.

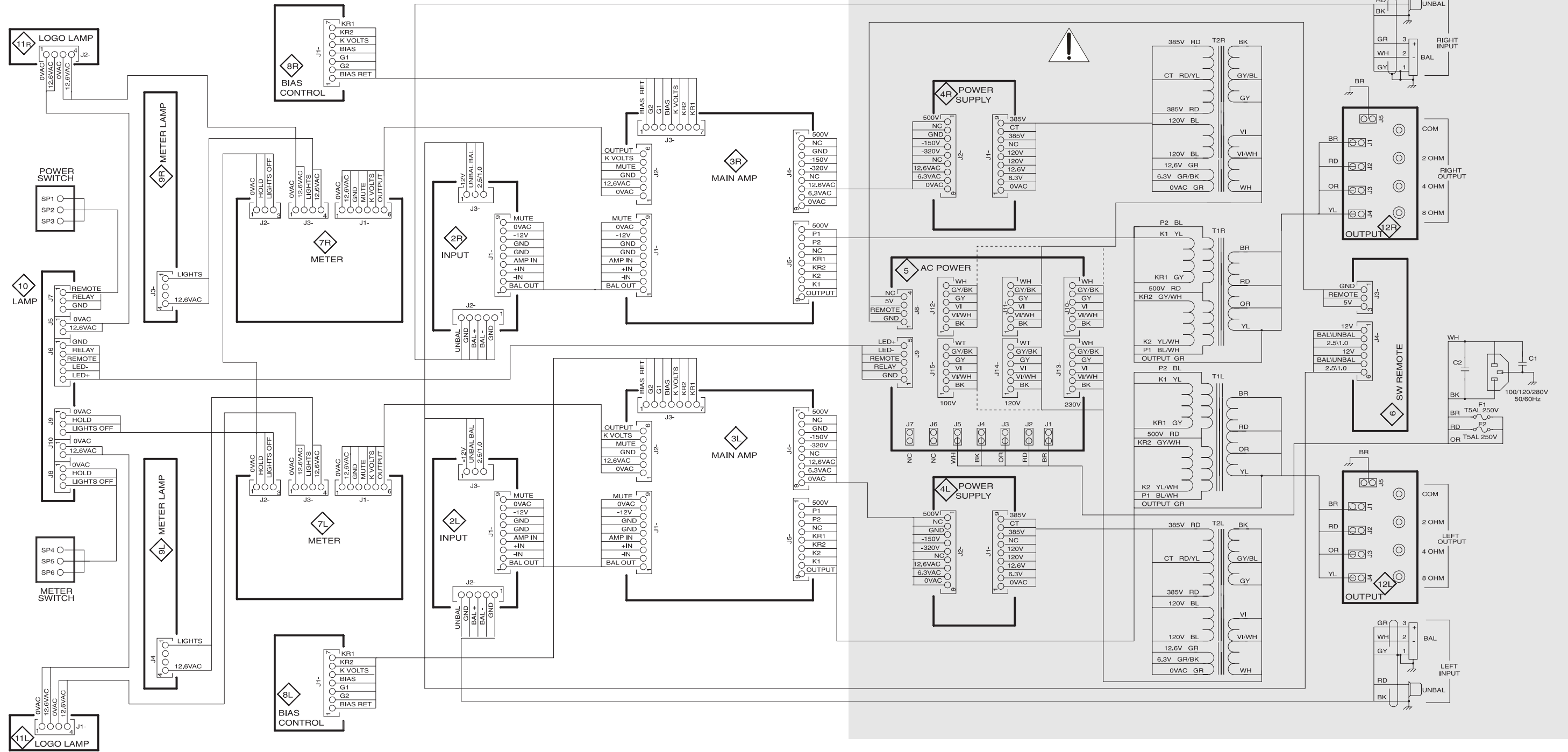

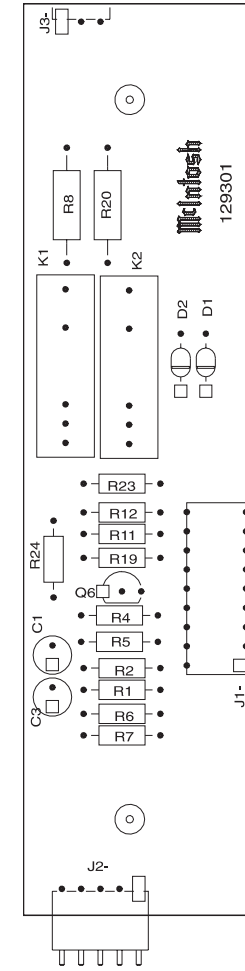
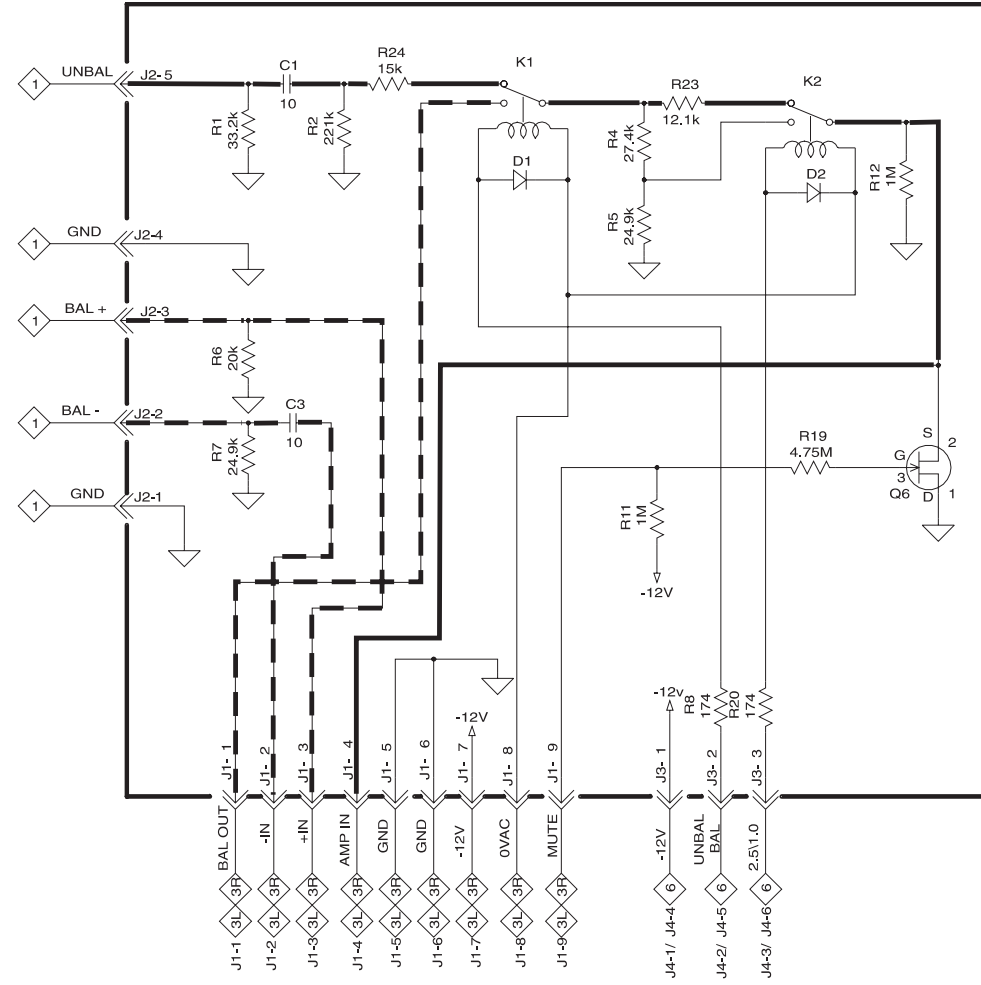

3R 3L MAIN 049306

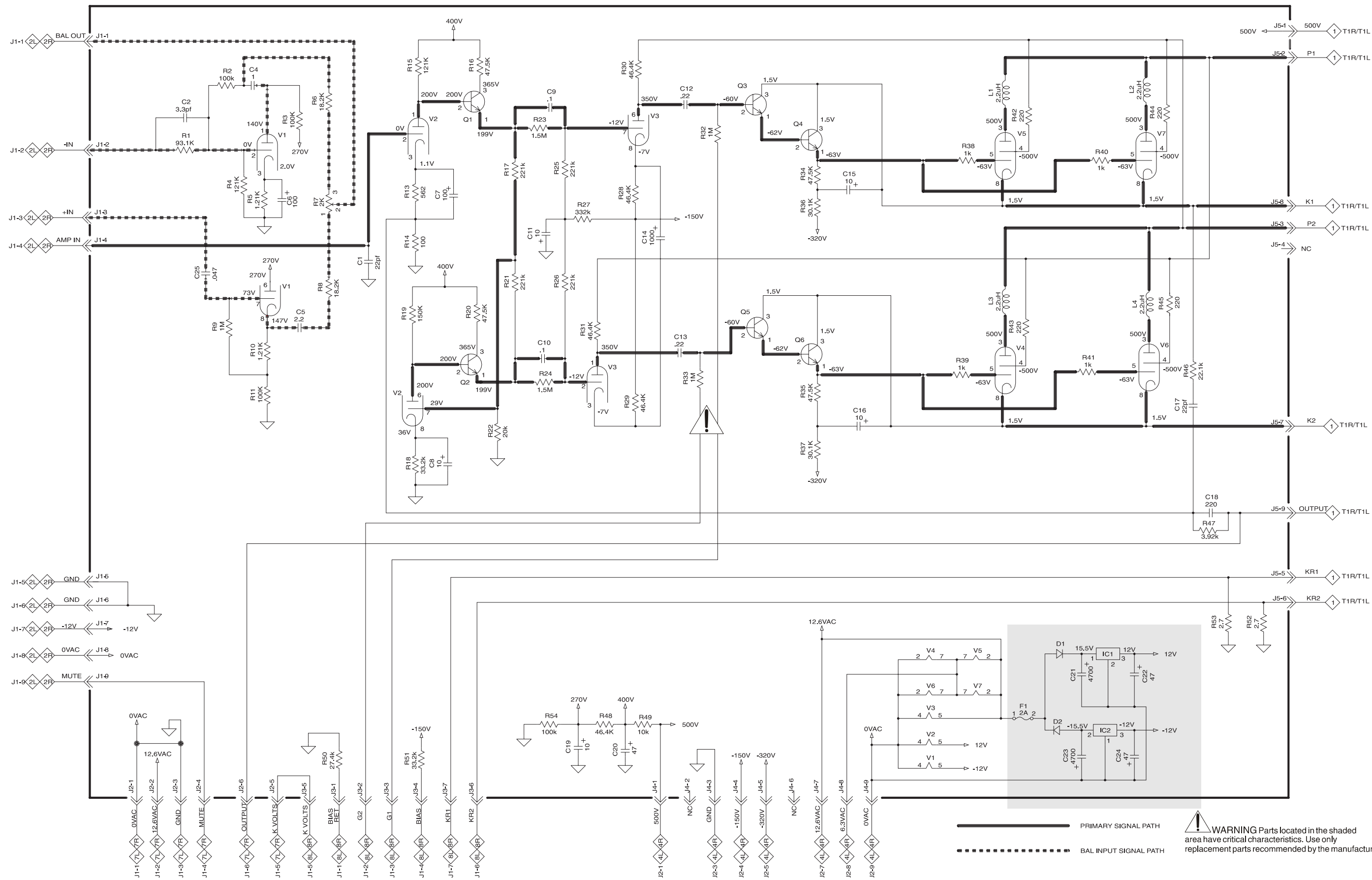

3R 3L MAIN 049306

MC2000

! WARNING Parts located in the shaded area have critical characteristics. Use only replacement parts recommended by the manufacturer.

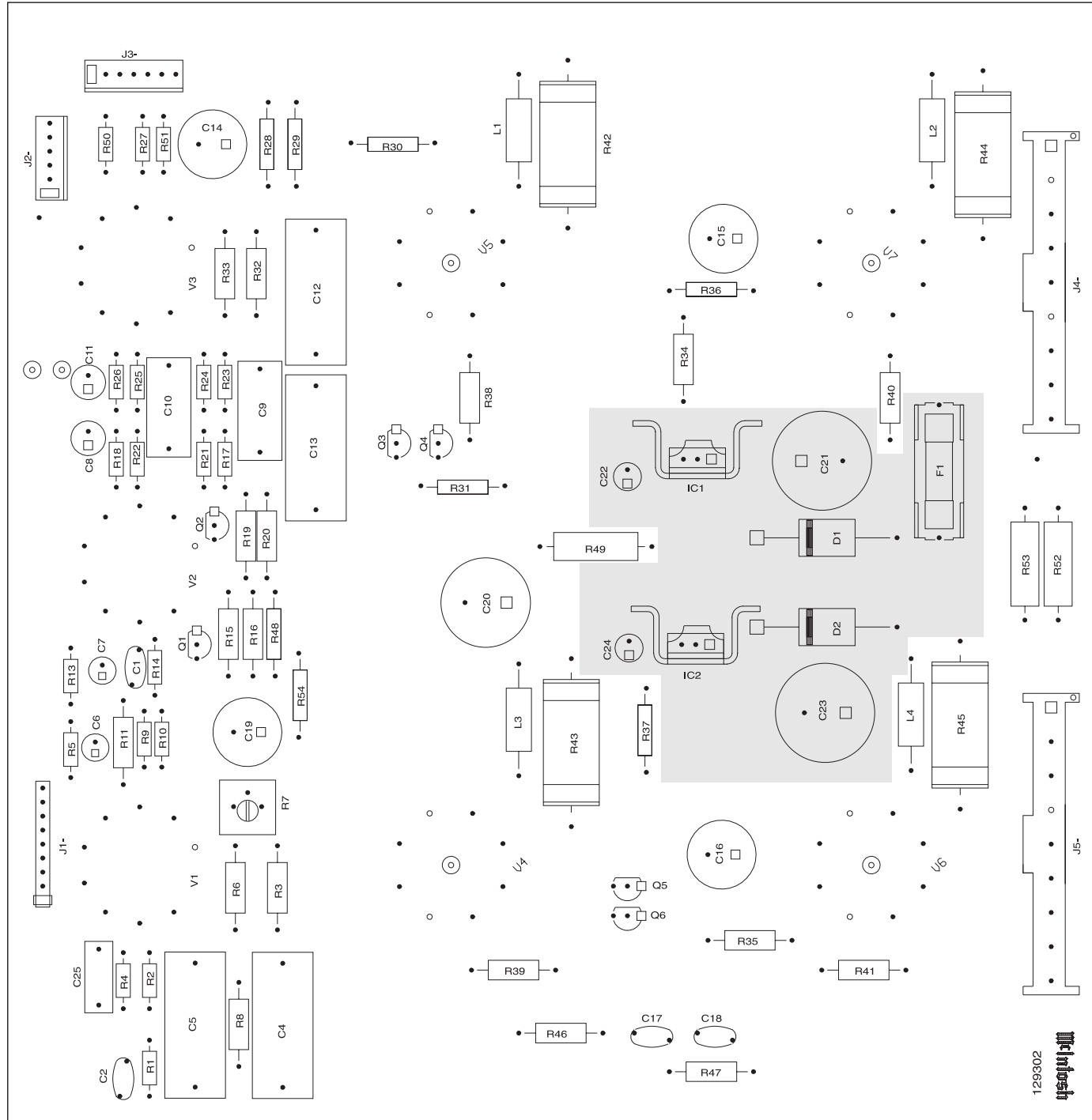

4R 4L POWER SUPPLY 049308

! WARNING Parts located in the shaded area have critical characteristics. Use only replacement parts recommended by the manufacturer.

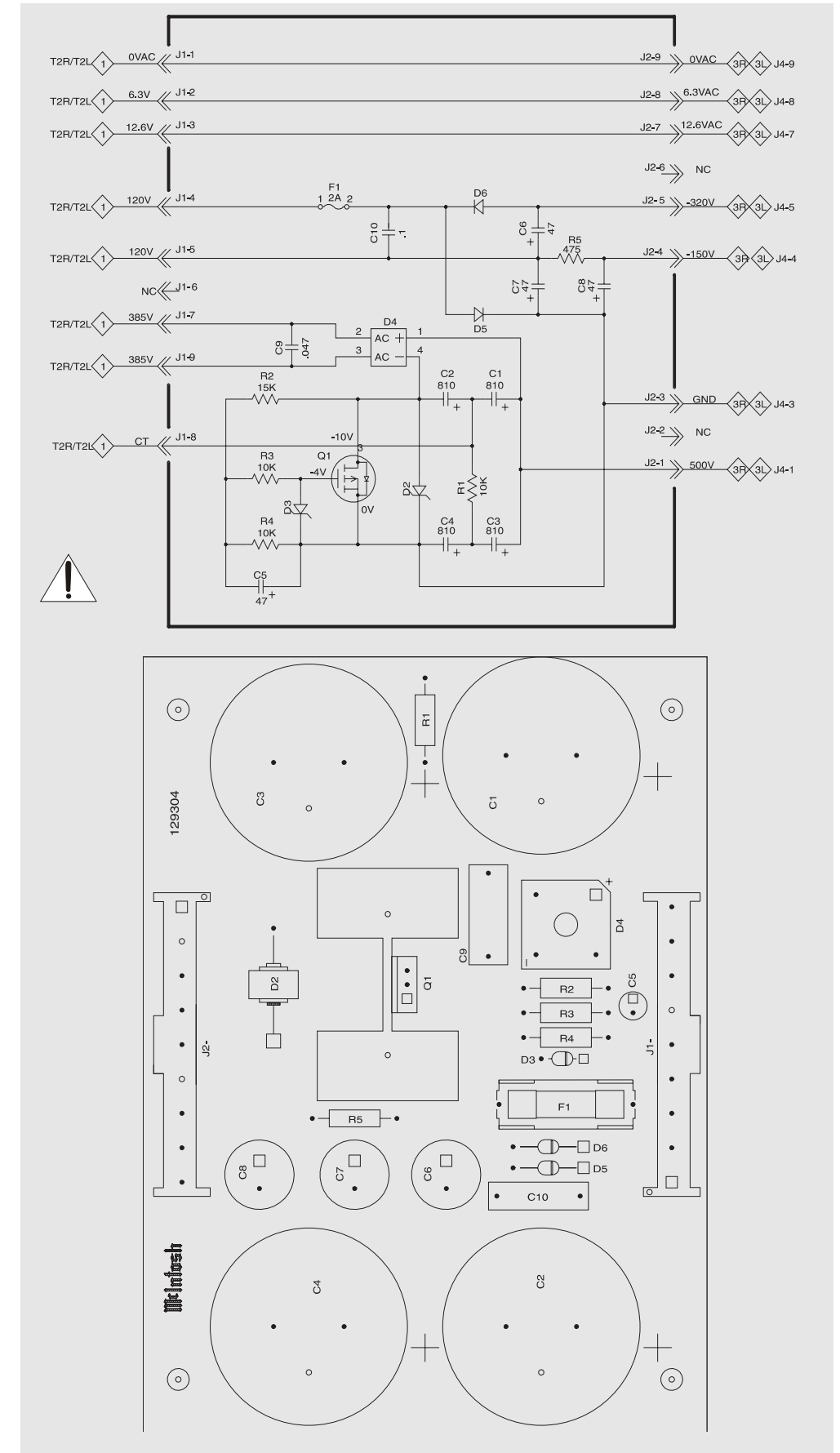

6 SWITCH REMOTE 049310

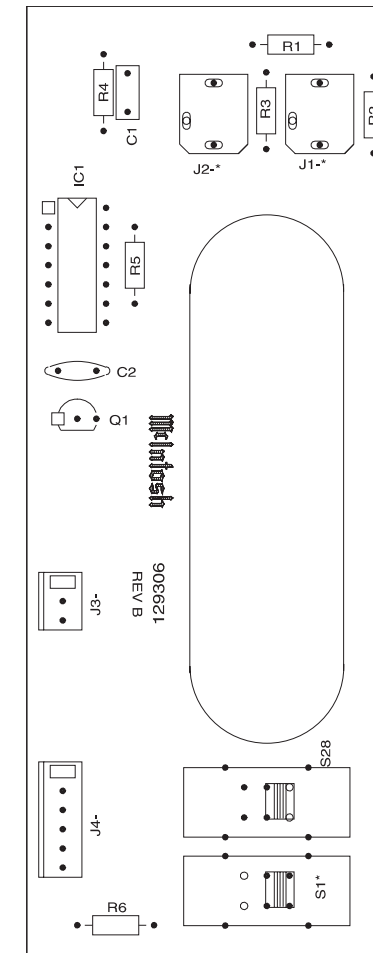
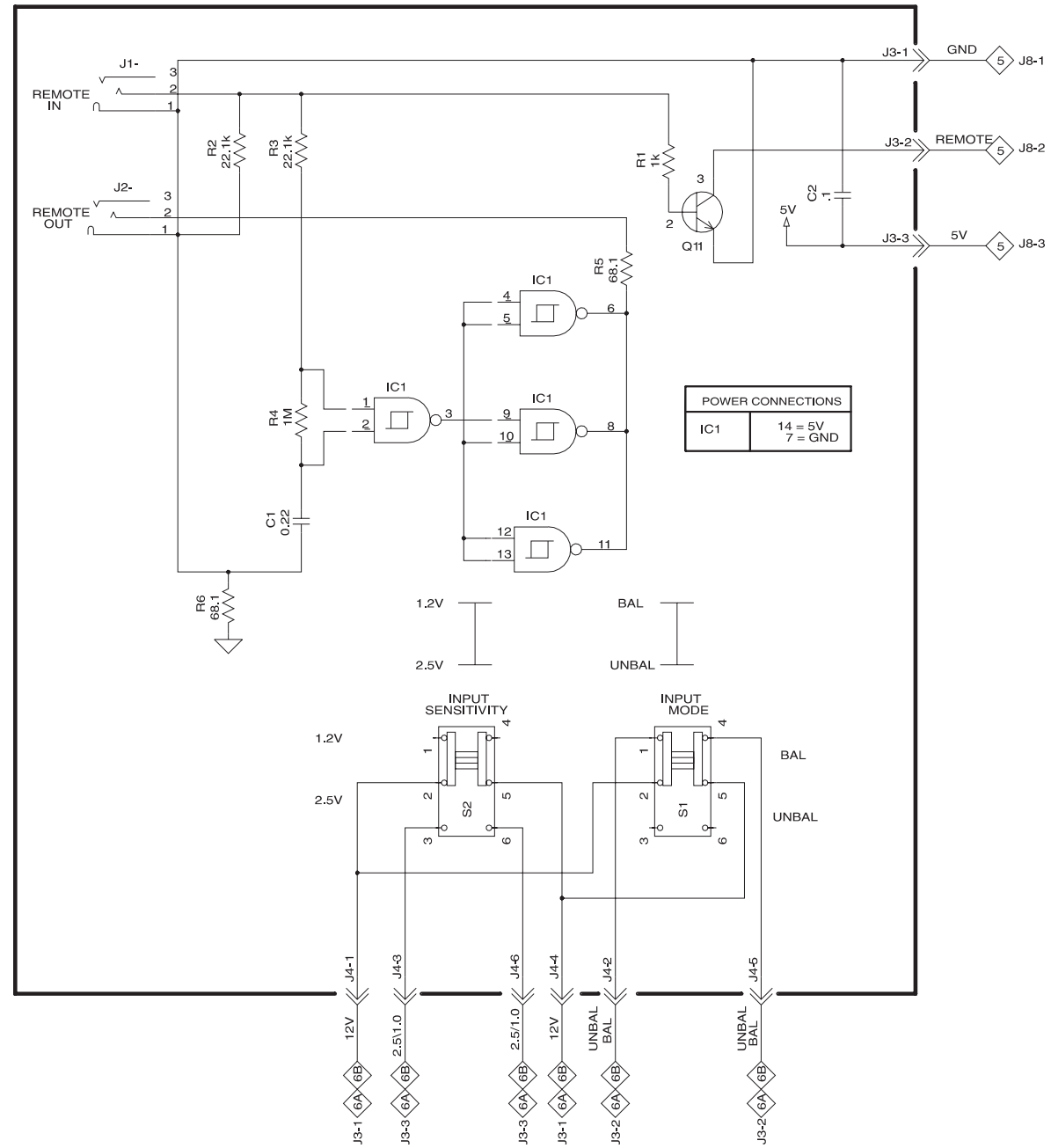

* DENOTES COMPONENTS ON REVERSE OR BACKSIDE OF PCB

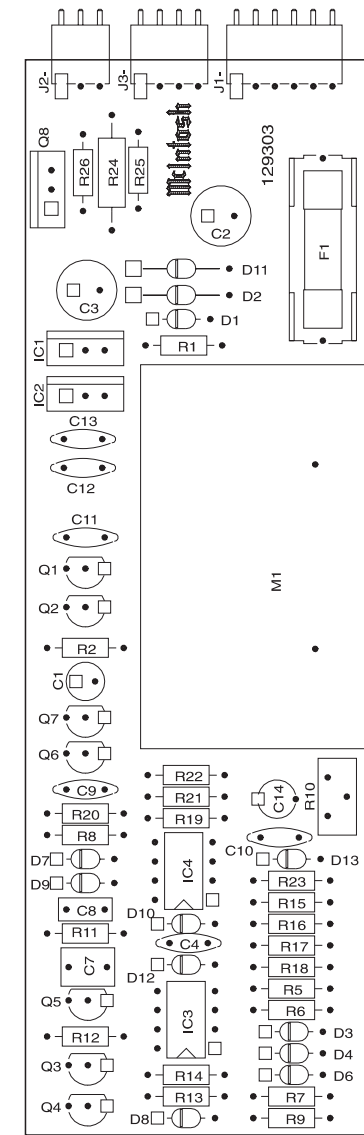
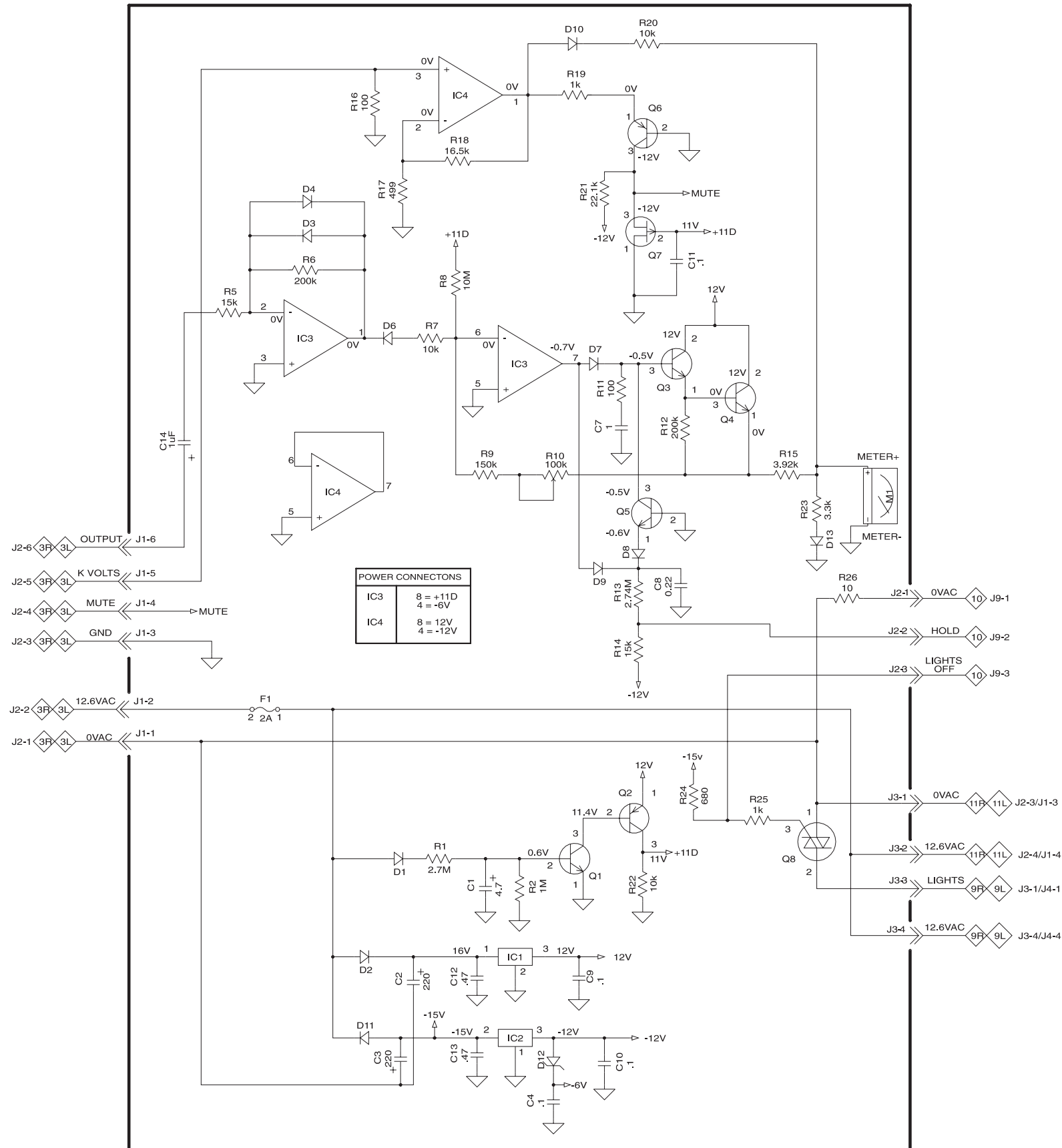

8R 8L *BIAS CONTROL* 049311

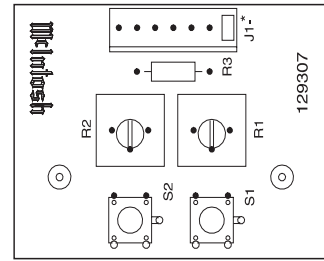
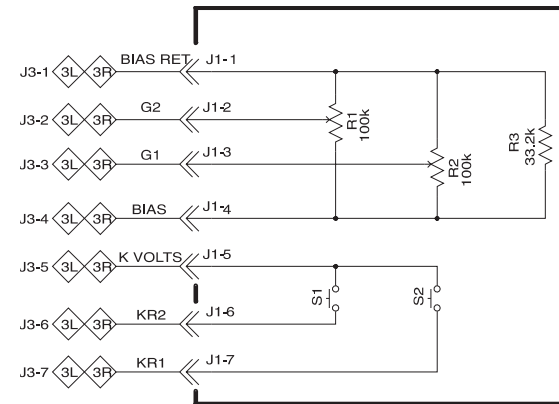

* DENOTES COMPONENTS ON REVERSE OR BACKSIDE OF PCB

9R 9L *METER LAMP* 049337

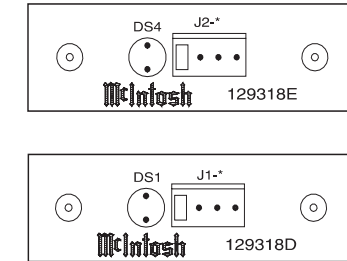
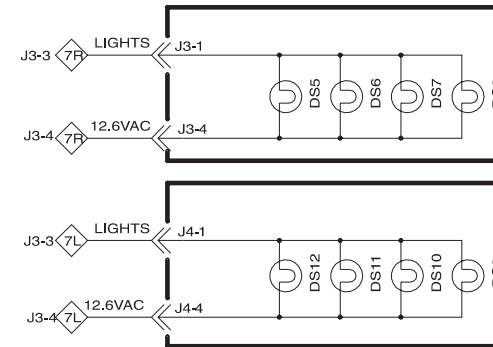

* DENOTES COMPONENTS ON REVERSE OR BACKSIDE OF PCB

10 *LAMP* 049311

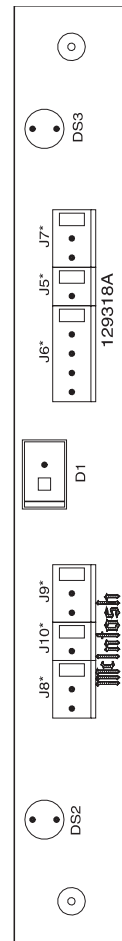
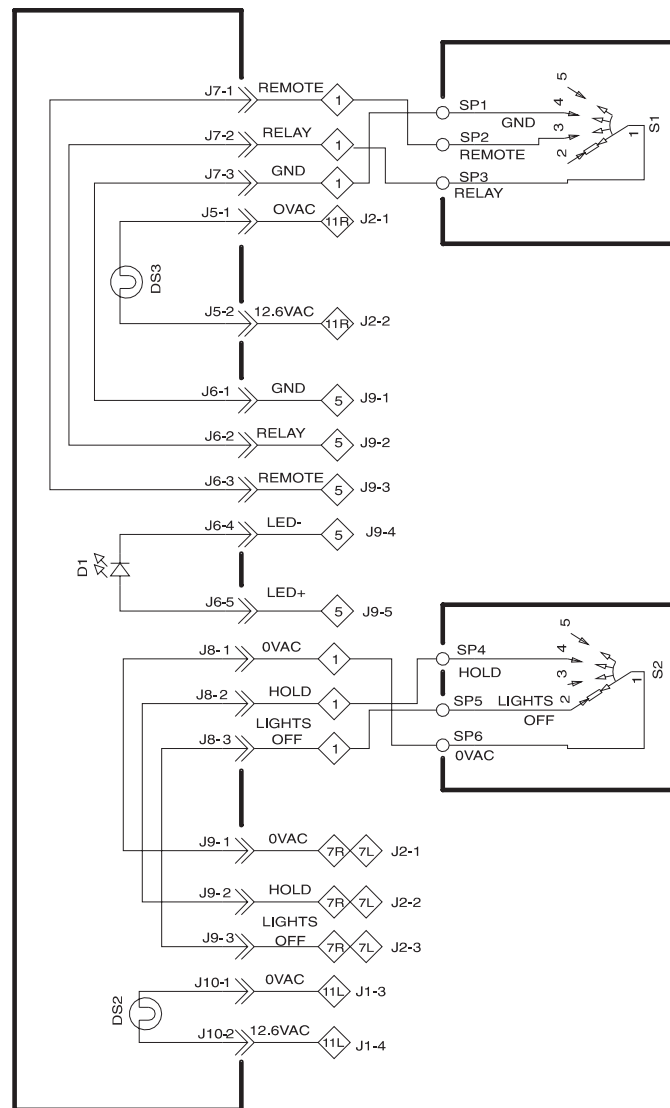

* DENOTES COMPONENTS ON REVERSE OR BACKSIDE OF PCB

11R 11L *LOGO LAMP* 049311

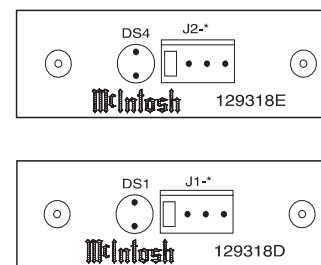
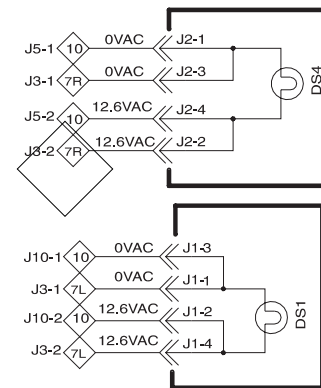

* DENOTES COMPONENTS ON REVERSE OR BACKSIDE OF PCB

12R 12L *OUTPUT* 049312

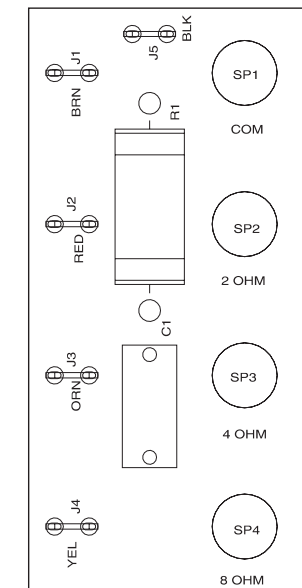
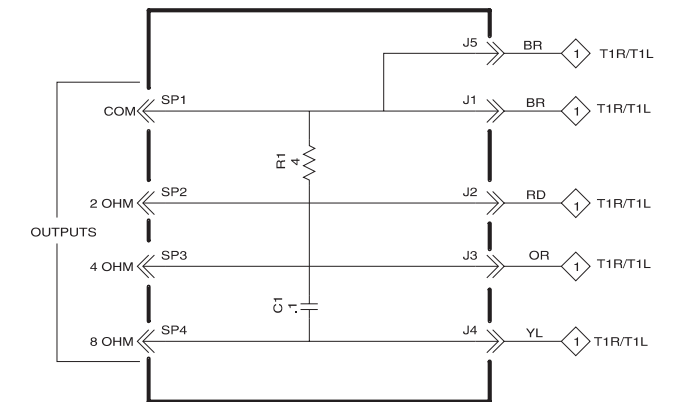

PARTS LIST

PART NO. DESCRIPTION REF. NO.

049305 Input

066316	CAP ELECT 10UF 20% 25V NP	C1 C3
070047	SILICON DIODE 1N4148 T&R	D1 D2
087056	REED RELAY FORM 1C 5V 125OHM	K1 K2
117216	MALE CONN 5 PIN 0.1 POST ASSY	J2-
117221	MALE CONN 3 POS RT ANGLE	J3-
117722	9 POSITION RECEPTACLE	J1-
132222	N. CHANNEL FET	Q6
144015	MF RES 33.2K 1% 1/4W	R1
144104	METAL FILM RES 20K 1% 1/4W	R6
144141	MF RES 27.4K 1% 1/4W	R4
144154	RES MF 12.1K 1% 1/4W	R23
144269	METAL FILM RES 1M 1/4W	R11 R12
144379	RES METAL FILM 4.75M 1/4W 1%	R19
144412	MF RES 15K 1% 1/4W	R24
144421	MF RES 221K 1% 1/4W	R2
144423	MF RES 174 OHM 1% 1/2W	R8 R20
144439	MF RES 24.9K 1% 1/4W	R5 R7

049306 Main

061293	DISC 22PF 500V	C1 C17
061295	DISC 3.3 PF 1000V	C2
061306	DISC 220 PF 100V	C18
064364	CAP POLYPROP .047MF 10% 250V	C25
064431	POLYPRO 0.1MF 630V	C9 C10
064432	POLYPRO 0.22MF 1000V 20%	C12 C13
064433	POLYPRO 1.0MF 250V 20%	C4
064435	POLYPRO 2.2 MF 250V 10%	C5
066492	ELECT 10MF 100V	C8 C11
066493	ELECT 10MF 250V	C15 C16
066494	ELECT 10MF 450V	C19
066495	ELECT 47MF 16V	C22 C24
066497	ELECT 47MF 450V	C20
066498	ELECT 100MF 6.3V	C6 C7
066500	ELECT 1000MF 16V NONPOLAR	C14
066502	ELECT 4700MF 25V	C21 C23
070126	DIODE 200V 3A	D1 D2
089088	FUSE 2A SLO-BLO 5 X 20 250VIEC	F1
117217	MALE CONN 7 PIN	J3-
117218	MALE CONN 6-POS FRICTION LK	J2-
117723	9 POSITION HEADER	J1-
117724	9 CIRCUIT POST HEADER NATURAL	J4-
117725	9 CIRCUIT POST HEADER RED	J5-
122001	CHOKE 2.2 MH	L1 L2 L3 L4
132136	TRANSISTOR NPN T092	Q1 Q2 Q3 Q4 Q5 Q6
133155	IC REGULATOR -12V	IC2
133156	IC REGULATOR 12V	IC1
134492	TRIM POT 2K 10%	R7
139009	WIRE RES 220 OHMS 10% 5W	R42 R43 R44 R45
139218	2.7 OHM 2W 5% WW RESISTOR FP	R52 R53
144104	METAL FILM RES 20K 1% 1/4W	R22
144106	33.2K 1% 1/4W	R18 R51
144113	RES MF 100K 1% 1/4W	R2
144119	METAL FILM RES: 332K 1% 1/4W	R27
144141	METAL FILM RES 27.4K 1% 1/4W	R50
144196	METAL FILM RES 100 OHM 1% 1/4W	R14
144269	METAL FILM RES 1M 1/4W	R9
144309	1K OHM 1% 1/2W METAL FILM	R38 R39 R40 R41
144408	MF RES 562 OHM 1% 1/4W	R13

144410	MF RES 1.2K 1% 1/4W	R5 R10
144414	MF RES 18.2K	R6 R8
144417	MF RES 93.1K 1% 1/4W	R1
144418	MF RES 121K 1% 1/4W	R4
144421	MF RES 221K 1% 1/4W	R17 R21 R25 R26
144422	MF RES 1.5M 1% 1/4W	R23 R24
144424	MF RES 3.92K 1% 1/2W	R47
144427	MF RES 22.1K 1% 1/2W	R46
144428	MF RES 47.5K 1% 1/2W	R16 R20 R34 R35
144429	MF RES 100K 1% 1/2W	R3 R11
144430	MF RES 121K 1% 1/2W	R15
144431	MF RES 150K 1% 1/2W	R19
144432	MF RES 1M 1/2W	R32 R33
144435	MO RES 30.1K 1% 1W	R36 R37
144436	MO RES 46.4K 1% 1W	R28 R29 R30 R31 R48
144437	MO RES 10K 5% 2W	R49
144438	MO RES 100K 5% 2W	R54
178169	OCTAL TUBE SOCKET CERAMIC	V4 V5 V6 V7
178170	9 PIN TUBE SOCKET CERAMIC	V1 V2 V3

049308 Power Supply

064431	POLYPRO 0.1MF 630V	C10
064434	POLY CAP .047UF 10% 1KV (MKP4)	C9
066495	ELECT 47MF 16V	C5
066496	ELECT 47MF 250V	C6 C7 C8
066503	ELECT 810MF 300V	C1 C2 C3 C4
070099	ZENER DIODE 12V 400MW	D3
070131	DIODE RECTIFIER	D5 D6
070165	BRIDGE RECT 1000V 6A	D4
070166	MR253L TRANS. SUPPRESSOR	D2
080017	TO-220 HEATSINK	Q1
089088	FUSE 2A SLO-BLO 5 X 20 250VIEC	F1
117724	9 CIRCUIT POST HEADER NATURAL	J2-
117725	9 CIRCUIT POST HEADER RED	J1-
132284	MTP2955V FET POWER TRANSISTOR	Q1
144415	MO RES 475 1% 1W	R5
144425	MF RES 10K 1% 1/2W	R1 R3 R4
144426	MF RES 15K 1% 1/2W	R2

049309 AC Power

066501	ELECT 3300MF 35V	C1
070031	SIL DIODE 400 PIV @ 1.5A (RED)	D2
087071	RELAY TV8 5V COIL	K1
089111	FUSE 50MA 5X20MM	F1
117215	4-PIN CONNECTOR	J8-
117216	MALE CONN 5-PIN 0.1 POST ASSY	J9
117719	PCB MOUNT POWER CONNECTOR RED	J10- J11- J12- J13- J14- J15- J1 J2 J3 J4 J5 J6 J7
133108	IC +5V REGULATOR	IC1
144090	METAL FILM RES 1K 1% 1/4W	R1
144282	THERMISTOR	RT1 RT2 RT3 RT4
159314	TRANSFORMER 115/230-8/16V 6VA	T1
178172	FUSE HOLDER 5X20MM	F1

049310 SW Remote

061248	DISC CAP .1MF 25V Y5T	C2
064329	CAP M POLY .22UF 5% 63VDC	C1
117214	MALE CONN 3-POS MTS100 NORMAL	J3
117218	MALE CONN 6-POS FRICTION LK	J4-
117406	MIN. PHONO JACK R657	J1- J2-

132171	TRANSISTOR NPN	Q1
133192	IC NAND SCHMIT 2-IN X 4	IC1
144082	METL FILM RES 68.1 OHM 1% 1/4W	R5 R6
144090	METAL FILM RES 1K 1% 1/4W	R1
144187	METAL FILM RES 22.1K 1% 1/4W	R2 R3
144269	METAL FILM RES 1M 1/4W	R4
148074	SLIDE SWITCH DPDT 3MM	S1 S2

049307 Meter

061248	DISC CAP .1MF 25V Y5T	C4 C9 C10 C11
061249	DISC CAP .47UF 50V MONOLITHIC	C12 C13
064329	CAP M POLY .22UF 5% 63VDC	C8
064337	POLY CAP 1MF 5% 50V	C7
066491	ELECT 4.7MF 100V	C1
066499	ELECT 220MF 25V	C2 C3
066510	CAP ELEC 1 UF 50V	C14
070047	SILICON DIODE 1N4148 T&R	D1 D3 D4 D6 D7 D8 D9 D10 D13

070085	ZENER DIODE 6.2V 5% 500MW	D12
070131	DIODE RECTIFIER	D2 D11
089088	FUSE 2A SLO-BLO 5 X 20 250VIEC	F1
117221	MALE CONN 3 POS RT ANGLE	J2-
117223	MALE CONN 6 PIN RT ANGLE	J1-
117240	4 PIN RT. ANGLE	J3-
131021	TRIAC 8A 200V	Q8
132223	TRANSISTOR NPN MPS4124 2K/REEL	Q1 Q5
132224	TRANSISTOR PNP	Q2 Q6
132226	TRANSISTOR P.CHANNEL JUNC.FET	Q7
132254	TRANSISTOR NPN	Q3 Q4
133155	IC REGULATOR -12V	IC2
133156	IC REGULATOR 12V	IC1
133260	DUAL OPERATIONAL AMPLIFIER	IC3 IC4
134383	TRIM POT 100K OHM 20%	R10
141060	RES CF 3.3K 5% 1/4W	R23
141125	RES CF 2.7M 5% 1/4W	R1
141136	RES CF10 5% 1/4W	R26
141179	CARB FILM RES 680 OHMS 5% 1/2W	R24
144053	RES MF 10K 1% 1/4W	R7 R20 R22
144053	RES MF10K 1% 1/4W	R7 R22
144087	MF 499 OHMS	R17
144090	METAL FILM RES 1K 1% 1/4W	R19 R25
144103	16.5K 1% 1/4W	R18
144117	METAL FILM RES 200K 1% 1/4W	R6 R12
144125	METAL FILM RES 150K 2% 1/4W	R9
144187	METAL FILM RES 22.1K 1% 1/4W	R21
144196	METAL FILM RES 100 OHM 1% 1/4W	R11 R16
144264	METAL FILM RES 10M 1% 1/4W	R8
144269	METAL FILM RES 1M 1/4W	R2
144271	METAL FILM RES 2.74M OHM 1/4W	R13
144411	MF RES 3.92K 1% 1/4W	R15
144412	MF RES 15K 1% 1/4W	R5 R14
144342	MF RES 13.7K 1% 1/4W	R20

049311 Bias Control

117217	MALE CONN 7 PIN	J1-
134497	TRIM POT 100K 10%	R1 R2
144106	33.2K 1% 1/4W	R3
150059	TACT SWITCH	S1 S2

049337 Lamp

146252	3 POSITION 2POLE ROTARY SWITCH	S1
--------	--------------------------------	----

049312 Output

064431	POLYPRO 0.1MF 630V	C1
117726	.187 FASTON TAB	J1 J2 J3 J4 J5
139119	WIRE RES 4 OHMS 5% 5W	R1

EXPLODED VIEW 1 OF 2

EXPLODED VIEW 2 OF 2

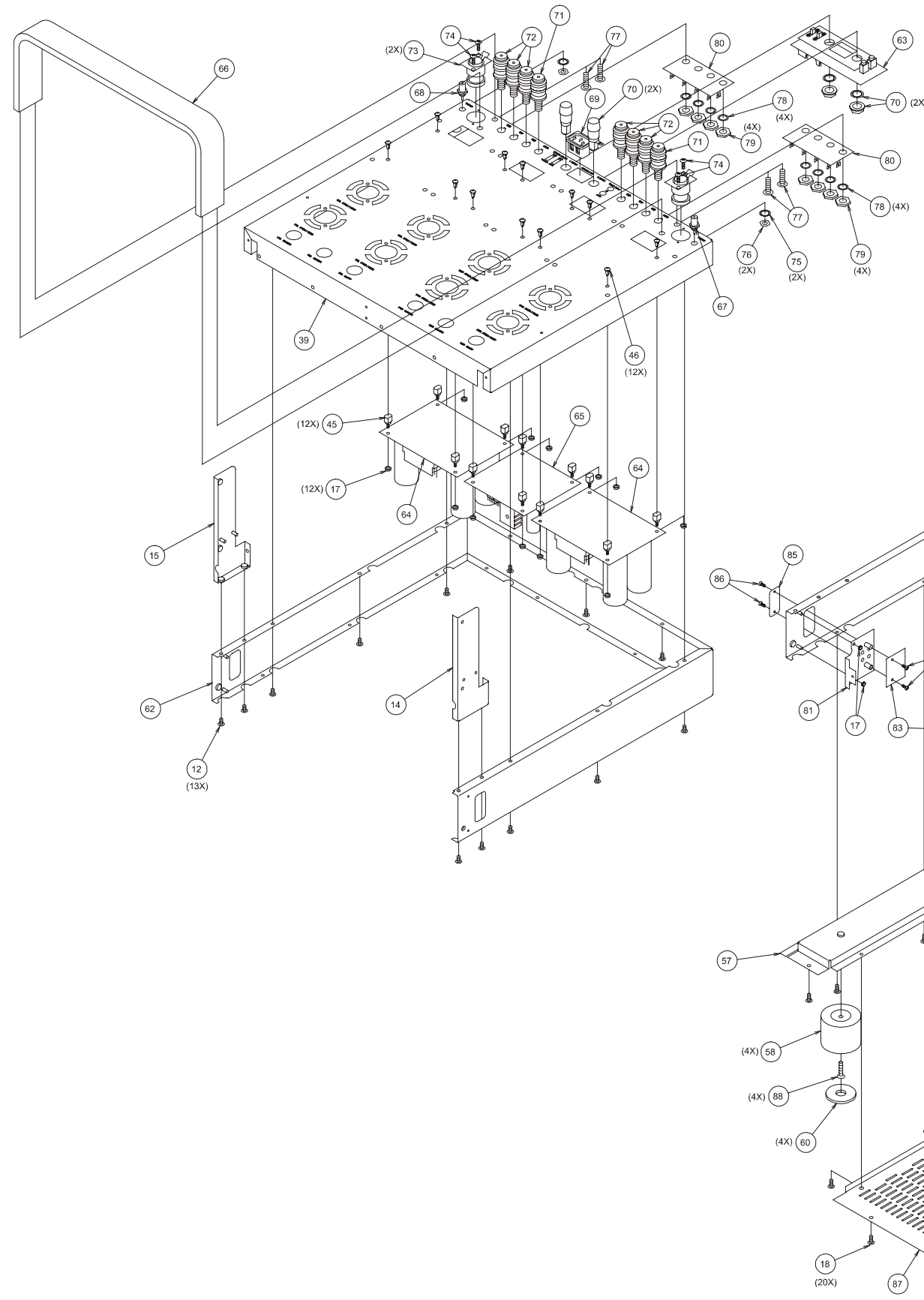

PARTS LIST

Ref. No.	Part No.	Description
1	016403	FRONT GLASS
2	049334	GOLD KNOB
3	104164	FELT WASHER
4	018628	HANDLE FRONT
5	018625	PANEL SIDE LEFT
6	018624	PANEL SIDE RIGHT
7	100200	MS 10-32 X 1/2 PHIL TRUSS BLK
8	017790	PLEXIGLAS PANEL
9	092424	METER COLOR FILTER
10	005007	PANEL PLATE
11	101142	CAP SCREW 1/4 -20 X 1-1/4
12	101215	SEMS MS 8-32 X 1/4 PHIL PAN
13	004961	DUST COVER
14	005006	GUSSET RIGHT
15	005005	GUSSET LEFT
16	005039	TOP SUBPANEL BRACKET
17	102003	MACH NUT: 6-32 W/LOCK
18	101078	TS 8-32 X 5/16 PHIL PAN BLK
19	126588	SIGNATURE NAMEPLATE
20	049379	WINDOW TRIM
21	101054	TS 6-32 X 1/4 PH PAN TAPTITE BLK

22	124071	METER
23	005008	SWITCH BRACKET
24	049357	METER ROTARY SWITCH PCB
25	049338	PANEL/LED LIGHT PCB
26	104163	M7 INTERNAL TOOTH LOCKWASHER
27	110004	M7 X .75 HEX CONTROL NUT
28	004970	SUBPANEL
29	092401	BLUE FILTER PALE
30	092400	BLUE FILTER AZURE
31	017749	METER LIGHT BOX
32	049336	METER LIGHT BOX PCB
33	114072	PLASTIC RIVET
34	049307	METER PCB
35	100296	SEMS 4-40 X 5/16 PHIL PAN
36	094360	FOAM TAPE 1/2" X 1/2"
37	094017	FOAM TAPE 1/4" X 1/4"
38	049339	PANEL LIGHT PCB
39	005018	CHASSIS GOLD
40	165065	12AX7A TUBE
41	165067	12AT7 TUBE
42	165069	KT88 TUBE
43	017761	AIR PIPE
44	049305	INPUT SWITCH PCB
45	114139	PCB SUPPORT
46	017801	PLASTIC RIVET
47	100292	MS 6-32 X 3/8 PH FH BLK ZINC
48	102006	MACH NUT: 10-32 W/LOCK
49	049304	POWER TRANSFORMER
50	126582	POWER TRANSFORMER DECAL
51	049301	OUTPUT TRANSFORMER
52	126581	OUTPUT TRANSFORMER DECAL
53	052093	TUBE COVER
54	101214	SCREW, TUBE COVER
55	049306	MAIN AMP PCB
56	004967	FOOT CHANNEL RIGHT
57	004968	FOOT CHANNEL LEFT
58	018626	FOOT
59	004971	CHASSIS SUPPORT
60	024010	FOOT PAD
61	005071	INPUT SHIELD BRACKET
62	005032	CHASSIS BASE
63	049310	SWITCH REMOTE PCB
64	049308	POWER SUPPLY PCB
65	049309	AC POWER PCB
66	018622	HANDLE REAR
67	117742	RCA JACK RED
68	117743	RCA JACK WHITE
69	117487	AC LINE RECEPTACLE
70	178122	FUSE HOLDER W/HARDWARE
71	117741	BINDING POST BLACK
72	117740	BINDING POST RED
73	117744	XLR RECEPTACLE
74	100195	MS 4-40 X 3/8 PHIL OVAL GOLD
75	104165	LW INTERNAL TOOTH
76	102052	NUT GOLD
77	100110	1/4-20 X 5/8 PAN PH BLK ZINC
78	104162	LOCKWASHER INTERNAL TOOTH
79	102051	HEX NUT M9 X .75 GOLD PLATED
80	049312	OUTPUT TERMINAL PCB
81	005035	BIAS PLATE LEFT
82	005036	BIAS PLATE RIGHT
83	049311	BIAS PCB
84	101193	SEMS 4-40 X 1/4 PHIL PAN BLK ZINC
85	004974	BIAS COVER
86	100193	MS 4-40 X 1/4 FLAT PH BLK ZINC
87	004969	BOTTOM COVER
88	100159	MS 10-32 X 3/4 PH PAN BLK ZINC

REPACKING INSTRUCTIONS

In the event it is necessary to repack the amplifier for shipment, the unit must be packed exactly as shown below.

IMPORTANT - The four feet must be attached to the bottom of the unit so they will locate in the four holes of the bottom foam pad. The vacuum tubes and tube cover must be removed and packed separately. Failure to do this will result in shipping damage.

Tape top and bottom cartons together along four edges with 3 inch packaging tape.

Use banding straps to make sure box is held together securely.

If a shipping carton or any of the interior parts are needed, please call or write the Customer Service Department of McIntosh Laboratory. Order parts from the accompanying list by part number.

Use the original shipping carton and interior parts only if they are in good serviceable condition.

Power Amplifier Carton

Qty.	Part No.	Description
1	033096	Poly bag
1	034097	Bottom foam pad
3	034098	Foam ring
1	034099	Top foam pad
1	034100	Inside carton top (white)
1	034101	Inside carton bottom (white)

Tube Set Carton (refer to page 7 in Owners's Manual for view of assembly)

Qty.	Part No.	Description
1	034109	Tube carton (gold) with foam pads

Accessory Carton (refer to page 7 in Owner's Manual for view of assembly)

Qty.	Part No.	Description
1	034108	Inside carton (white)
1	034111	Outside carton (kraft)
1	034112	Foam pad set

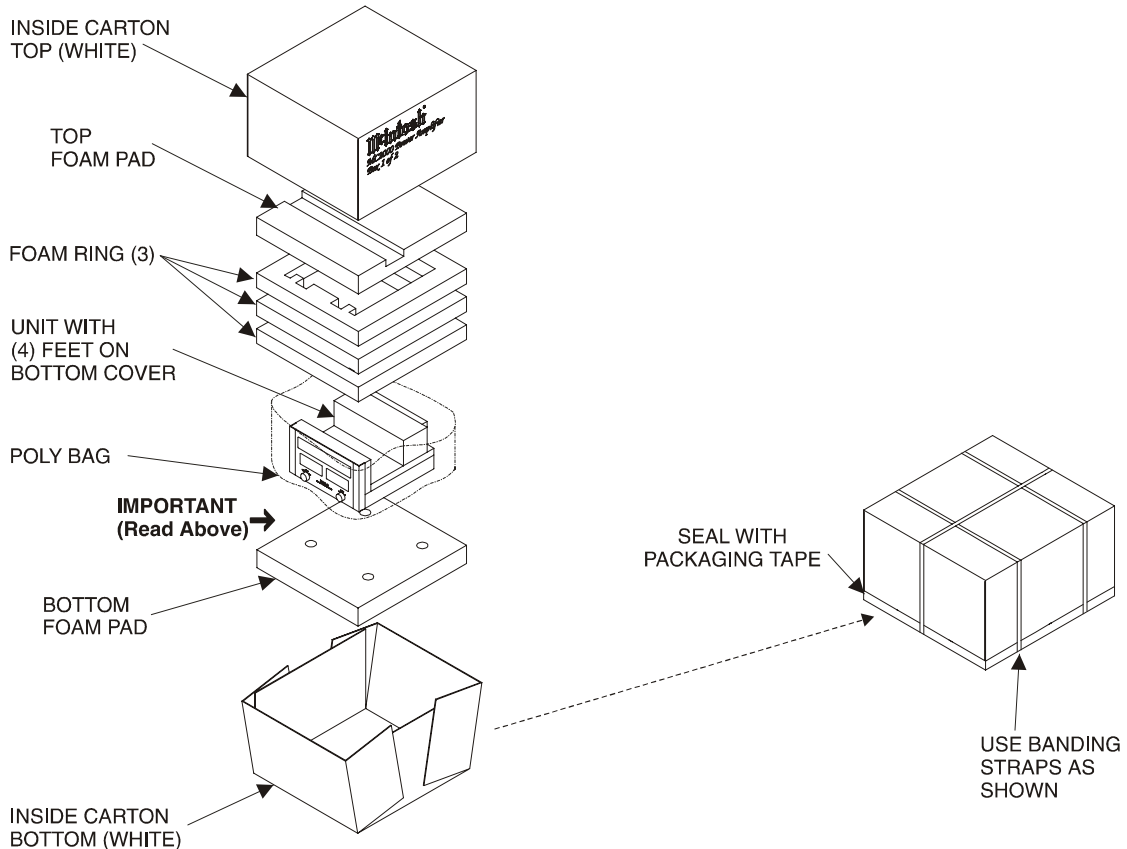

MC2000

POWER AMPLIFIER

SERVICE MANUAL

The continuous improvement of its products is the policy of McIntosh Laboratory Incorporated, who reserve the right to improve design without notice. Because of the constant upgrading of McIntosh products' circuitry and components, the Company cannot insure, and does not warrant, the accuracy of the within schematic material, which is intended for information only.