

# MC202

## POWER AMPLIFIER

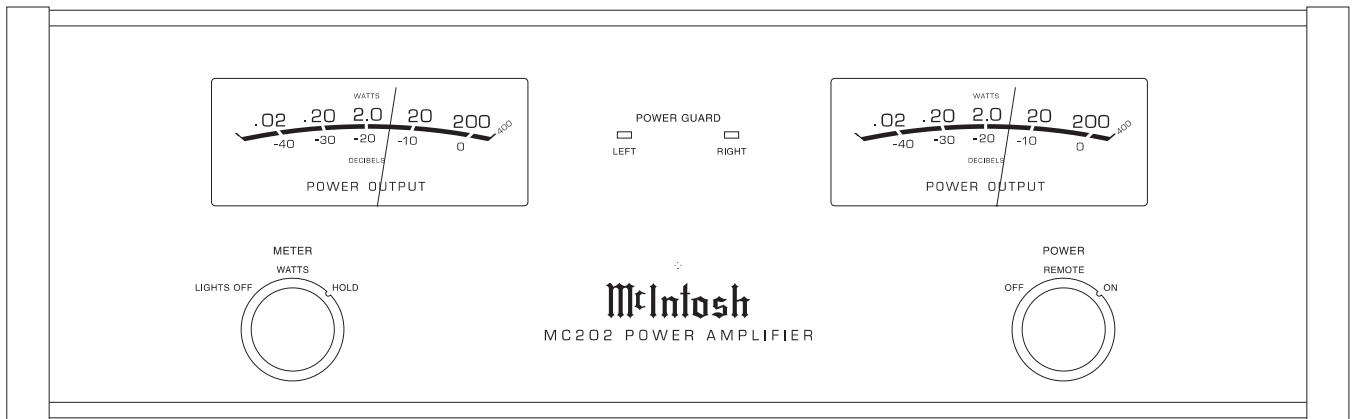

### CONTENTS

Performance Specifications .....	2	Meter Schematic and PCB .....	13 - 19
Notes .....	2	Power Guard Lamp Schematic and PCB .....	16
Rear Panel .....	3	Meter Light Schematic and PCB .....	17
Section Location .....	3	Panel Lamp Schematic and PCB .....	18
Block Diagram .....	5 - 6	Parts List .....	19 - 20
Interconnection Diagram .....	7 - 8	Exploded View and Parts List .....	21 - 24
Heatsink Schematic and PCB .....	9 - 10	Repacking Instructions .....	25
Driver Schematic and PCB .....	11 - 12		

# McIntosh

## SERVICE MANUAL

# PERFORMANCE SPECIFICATIONS

## Power Output Stereo

200 watts into 2, 4 or 8 ohm loads is the minimum sine wave continuous average power output per channel with both channels operating.

## Power Output Mono Bridged

400 watts into 4, 8 or 16 ohm loads is the minimum sine wave continuous average power output.

## Output Load Impedance

Stereo - 2, 4 or 8 ohms  
Mono - 4, 8 or 16 ohms

## Rated Power Band

20Hz to 20,000Hz

## Dynamic Headroom

1.9dB

## Frequency Response

+0, -0.25dB from 20Hz to 20,000Hz  
+0, -3dB from 10Hz to 100,000Hz

## Total Harmonic Distortion

0.005% maximum at any power level from 250 milliwatts to rated power per channel from 20Hz to 20,000Hz, all channels operating.

## Intermodulation Distortion

0.005% maximum if instantaneous peak output per channel does not exceed twice the rated output with all channels operating for any combination of frequencies from 20Hz to 20,000Hz.

## Signal To Noise Ratio (A Weighted)

110dB below rated output

## Sensitivity

1.7 Volts Unbalanced Input  
3.4 Volts Balanced Input

## Input Impedance

10,000 ohms Unbalanced and Balanced

## Wide Band Damping Factor

Greater than 40

## Power Requirements

100 Volts, 50/60Hz at 4.8 amps  
110 Volts, 50/60Hz at 4.4 amps  
120 Volts, 50/60Hz at 4.0 amps  
220 Volts, 50/60Hz at 2.0 amps  
230 Volts, 50/60Hz at 2.0 amps  
240 Volts, 50/60Hz at 2.0 amps

*Note: Refer to the rear panel of the MC202 for the correct voltage.*

## Dimensions

Front Panel: 17-1/2 inches (44.45cm) wide, 5-7/16 inches (13.81cm) high. Depth behind front mounting panel is 18 inches (45.72cm). Clearance required in front of the Front Panel is 1 inch (2.54cm) for knobs.

## Weight

65 pounds (29.49 kg) net, 83 pounds (37.65 kg) in shipping carton.

# NOTES

1. The heavy notes on the schematic denote the primary signal path.
2. Unless otherwise noted, all voltages indicated on the schematics are measured under the following conditions:
  - a. AC input at 120 volts, 50/60Hz.
  - b. All voltages are +/-10% with respect to ground. A high impedance (10 megaohm) voltmeter must be used.
3. Unless otherwise specified:
  - a. Resistor values are in ohms.
  - b. Capacitor values are microfarads (uF).
  - c. Inductor values are in microhenries (uH).
4. On PC board drawings, Square pad indicates:
  - a. Polarized Capacitors - Positive
  - b. Diodes - Cathode
  - c. Others - Pin 1
5. **WARNING**  Parts marked with the symbol have critical characteristics. Use only replacement parts recommended by the manufacturer.

# REAR PANEL

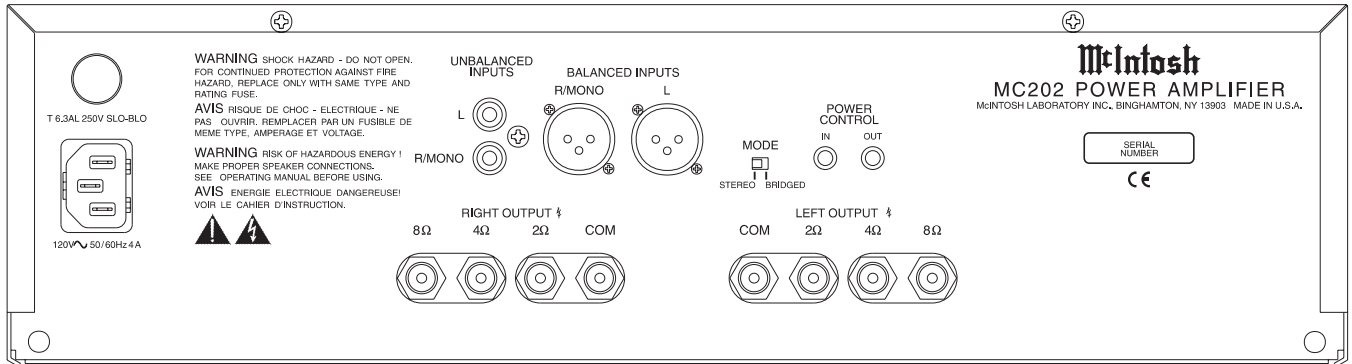

# SECTION LOCATIONS

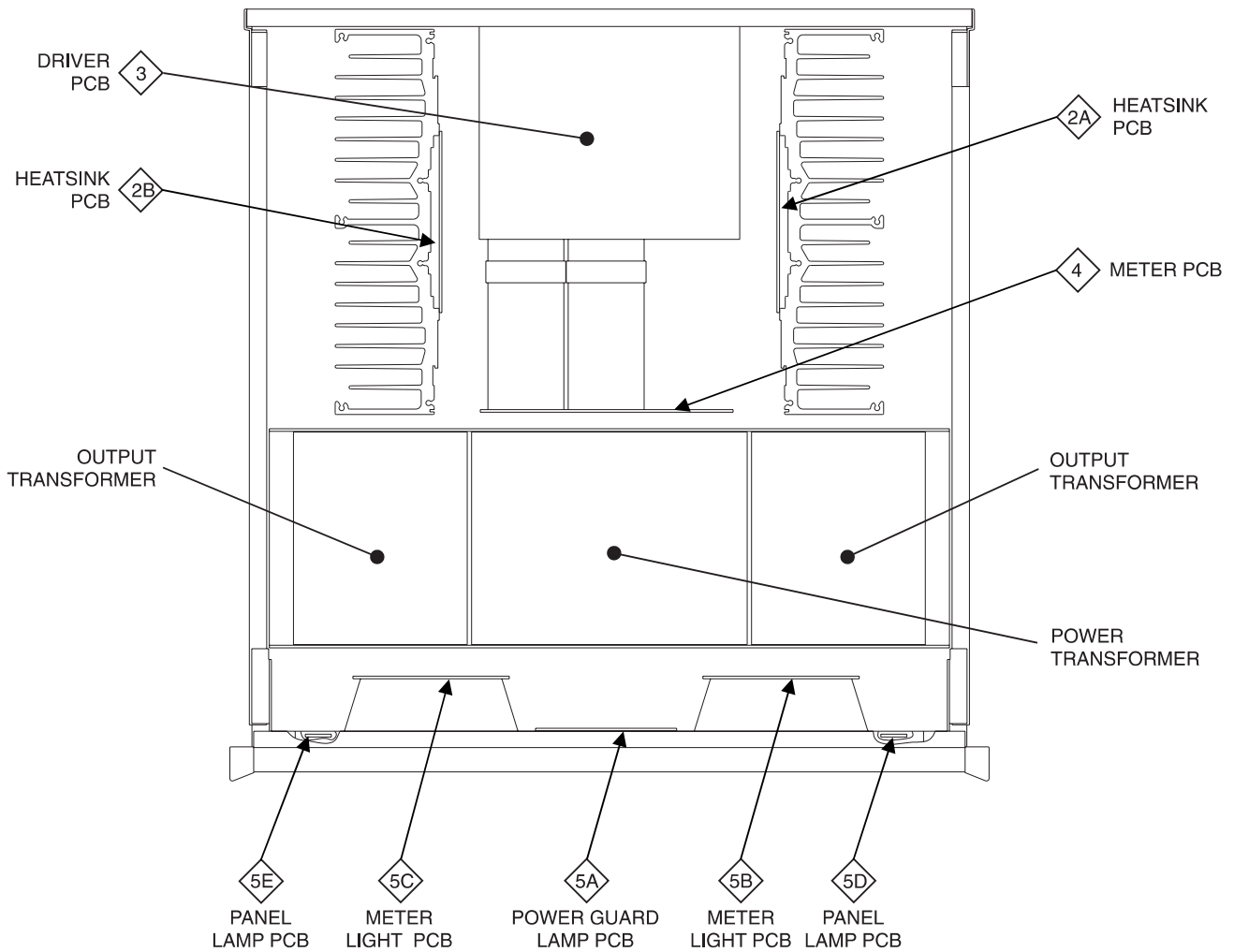

# *NOTES*

# BLOCK DIAGRAM

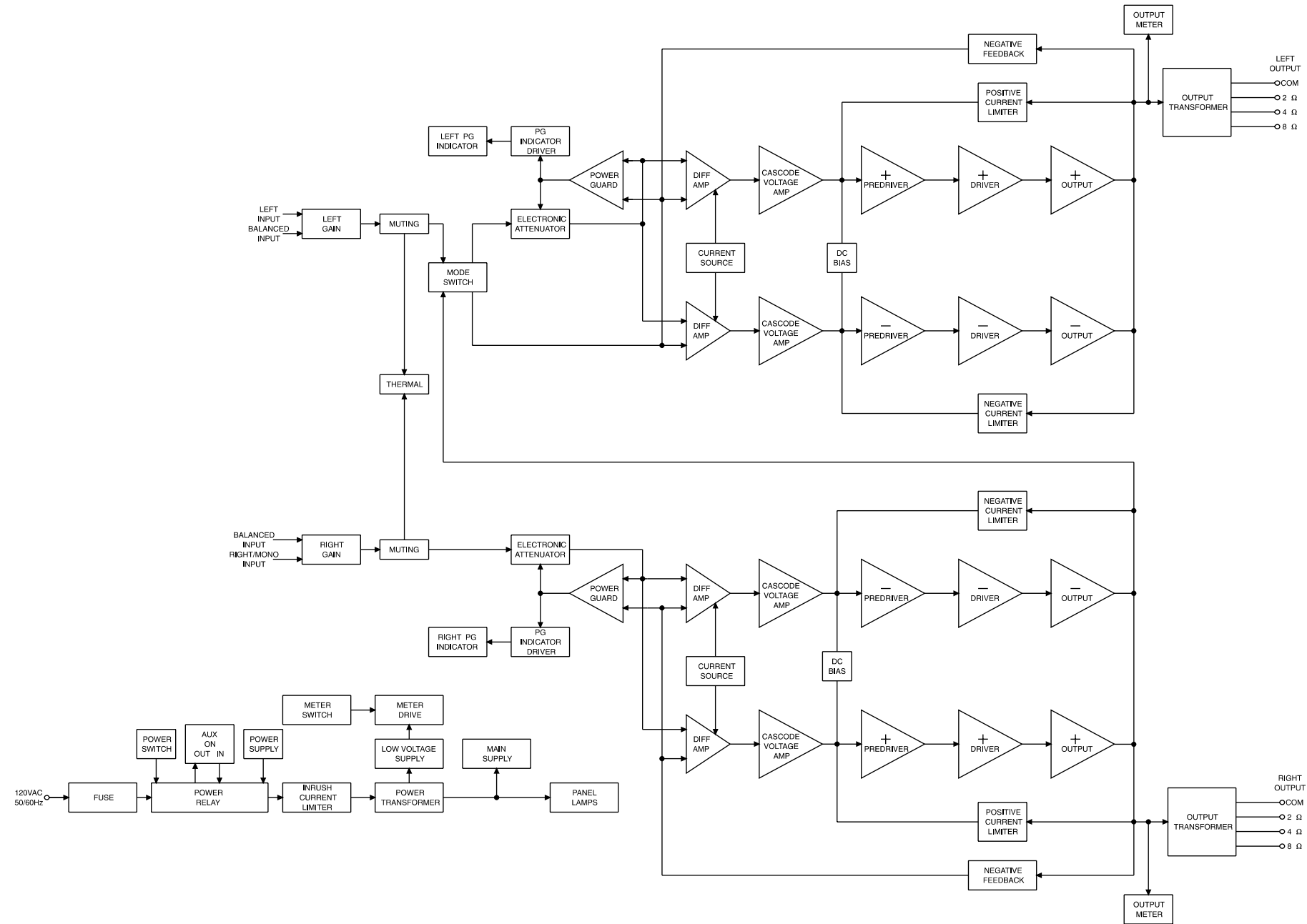

# INTERCONNECT

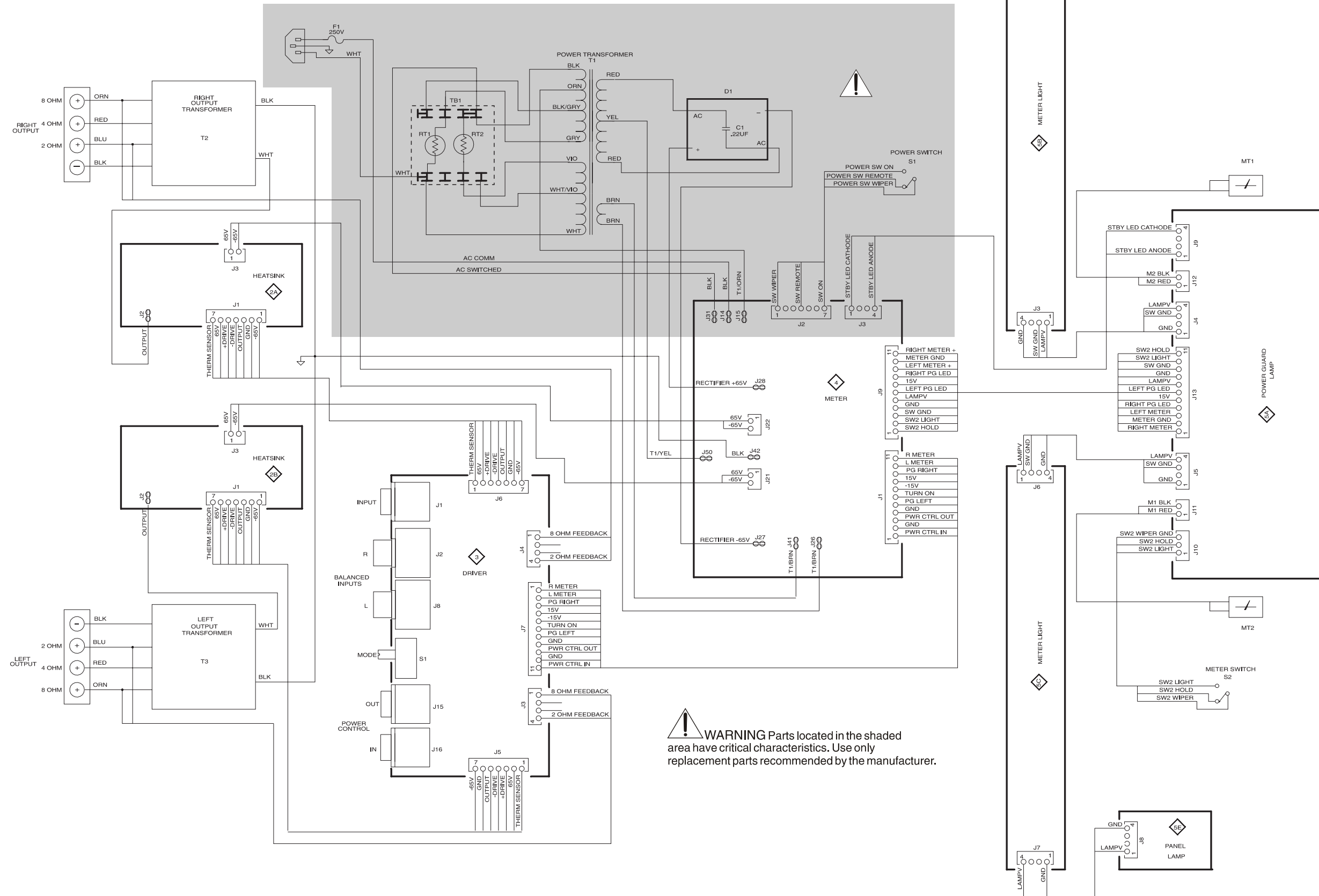

**2A 2B** HEATSINK 049346

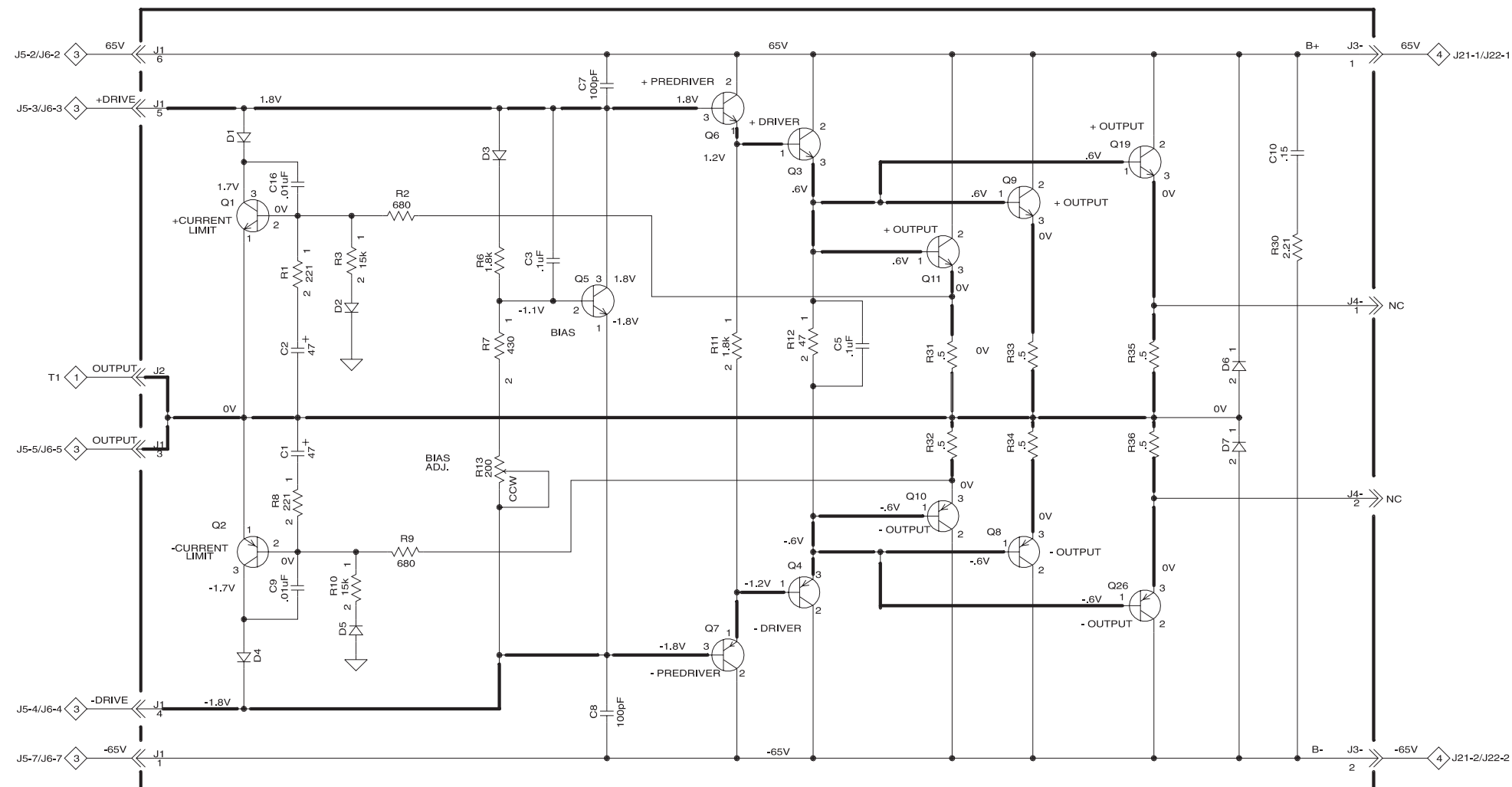

BIAS ADJ: ADJUST R13 FOR  
12mV +/-3mV ACROSS J4-1 AND J4-2  
WITH NO INPUT SIGNAL AND HEATSINKS COOL.

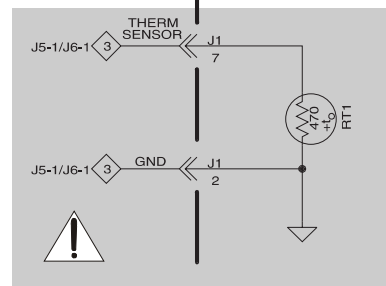

**WARNING** Parts located in the shaded area have critical characteristics. Use only replacement parts recommended by the manufacturer.

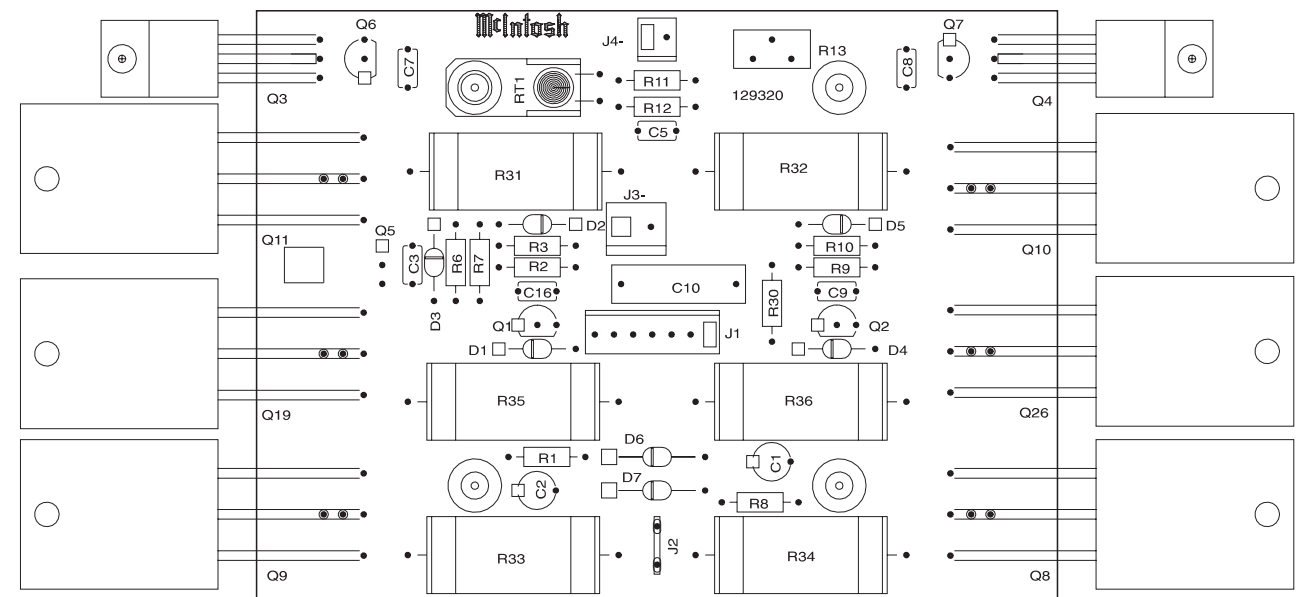

# 3 DRIVER 049353

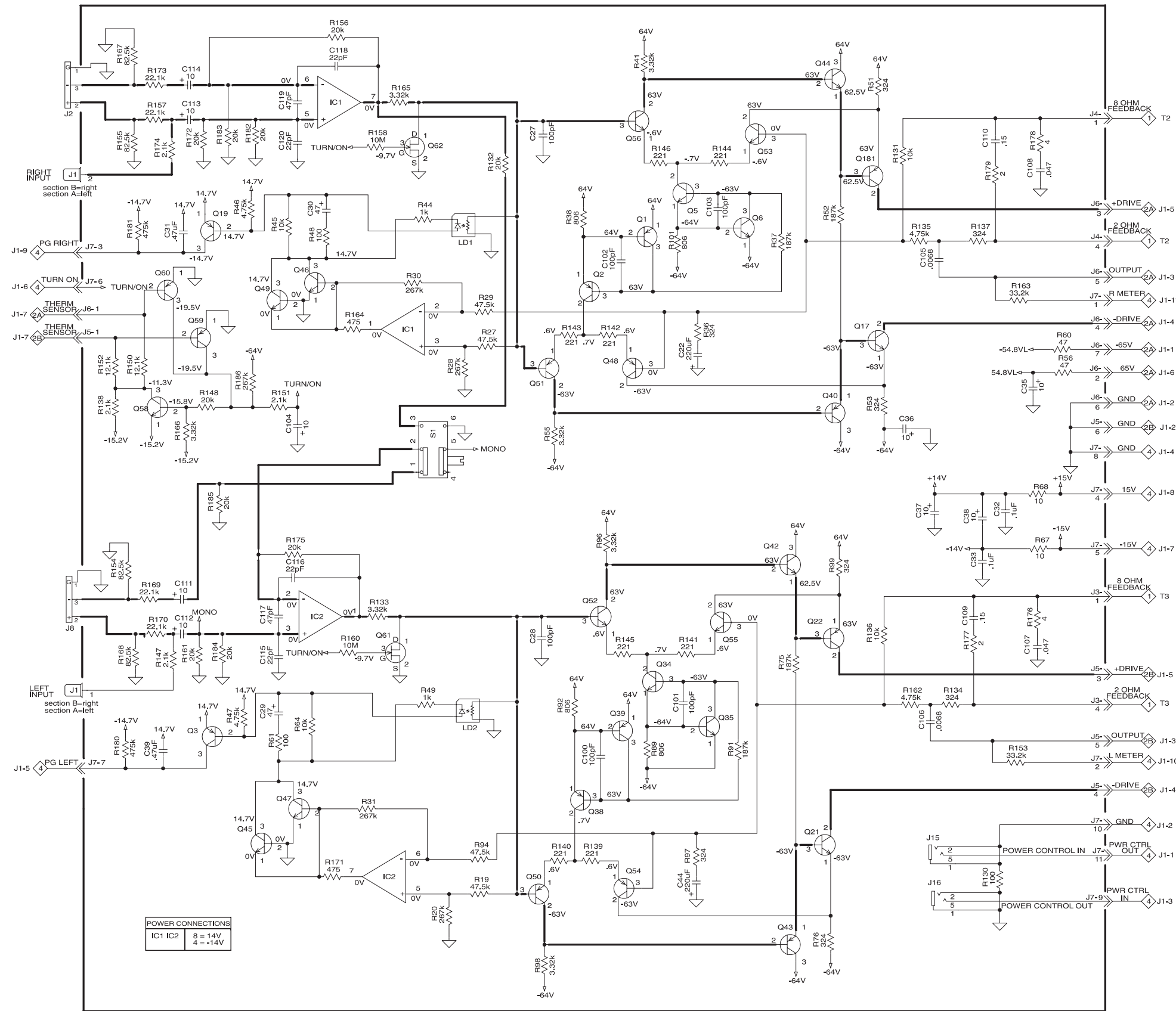

POWER CONNECTIONS	
IC1	8 = 14V
IC2	4 = -14V

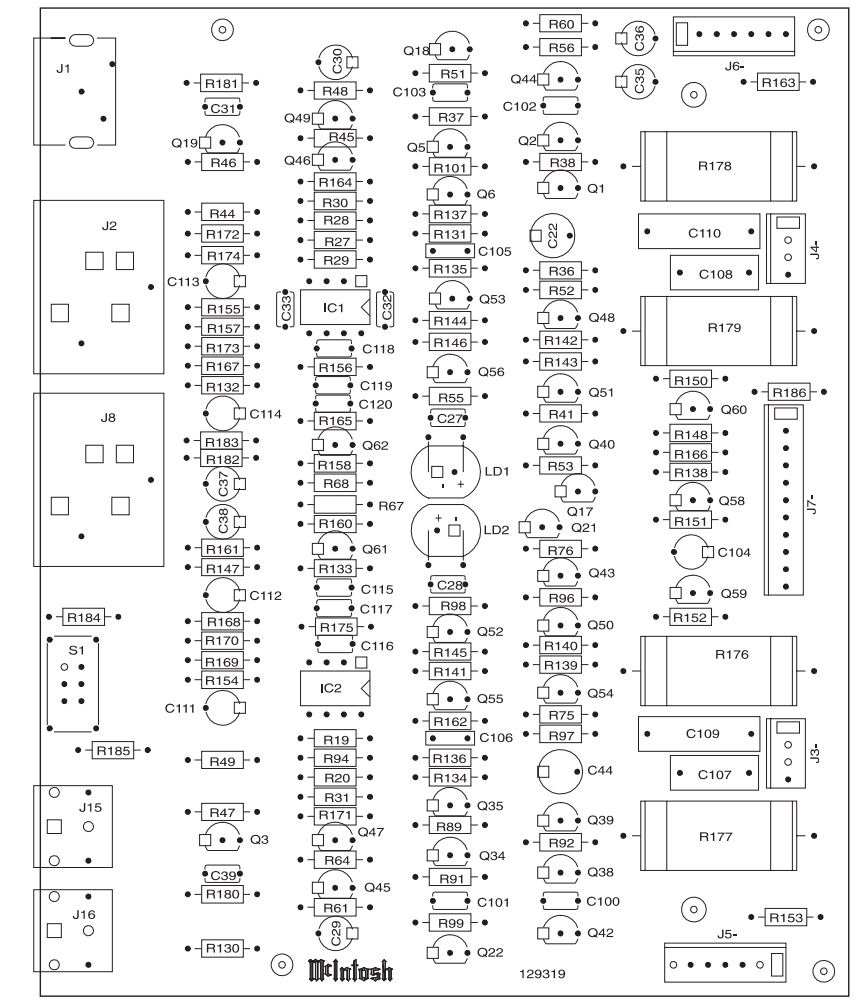



**4** METER 049352

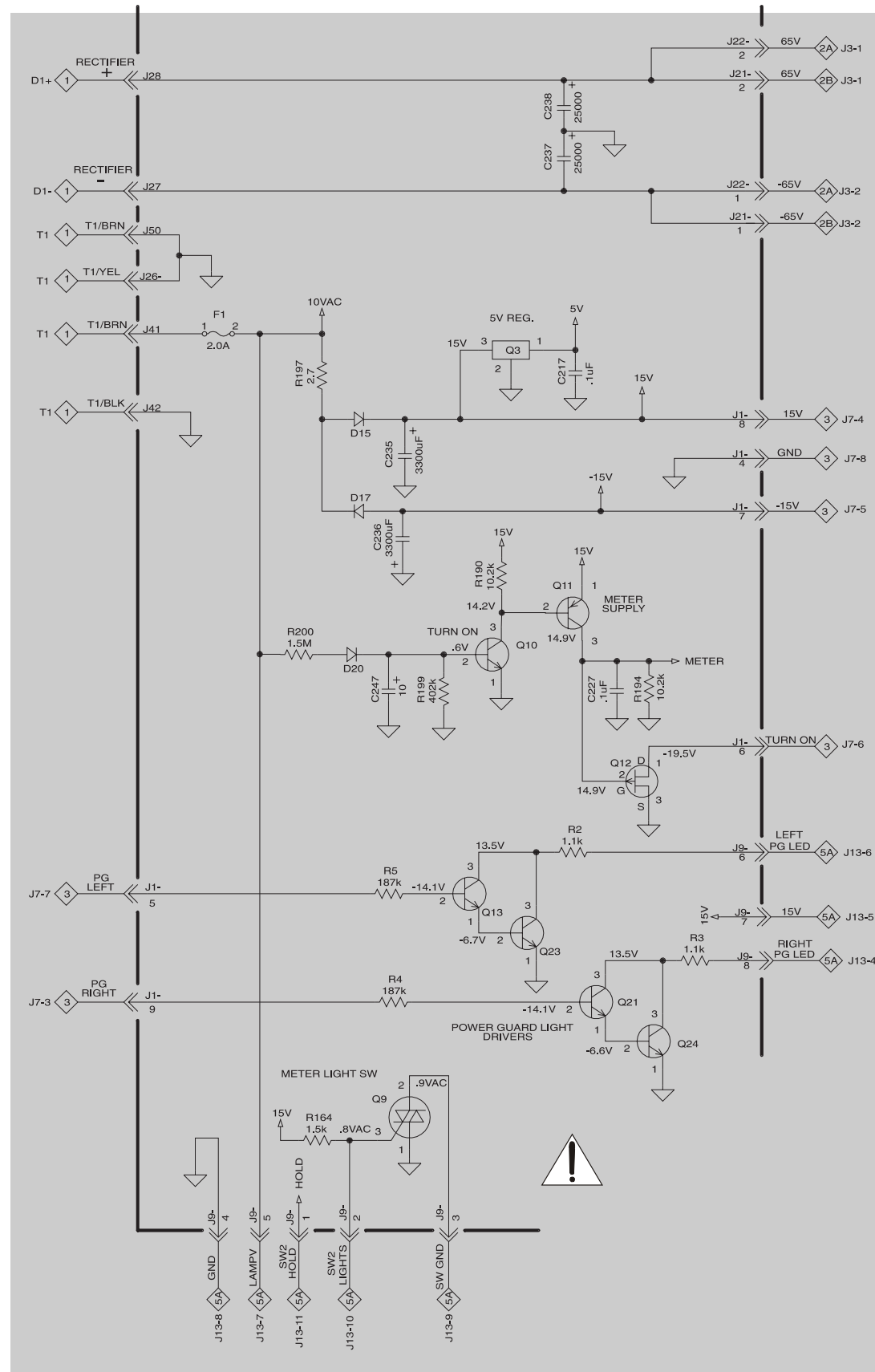

# 4 METER 049352

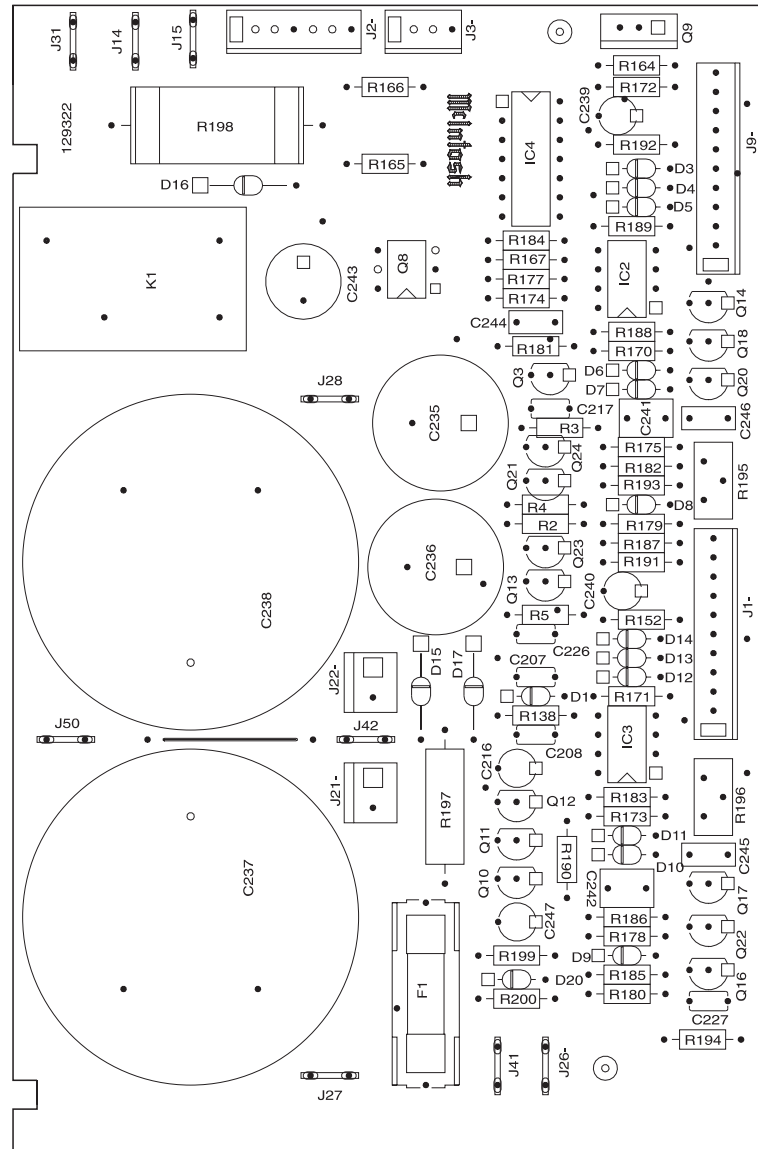

# 5A POWER GUARD LAMP 049354

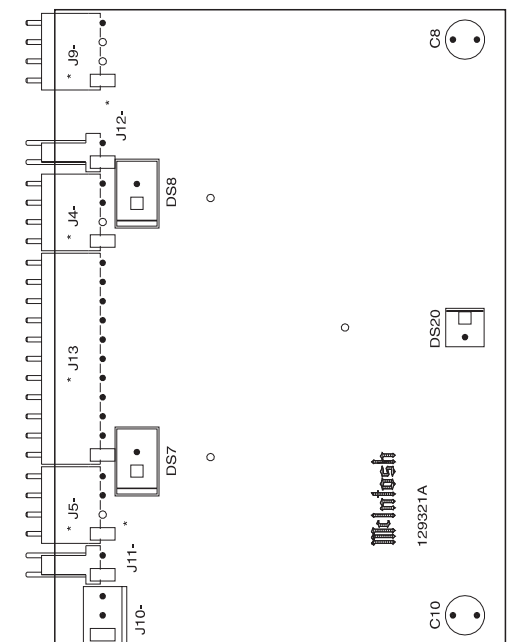
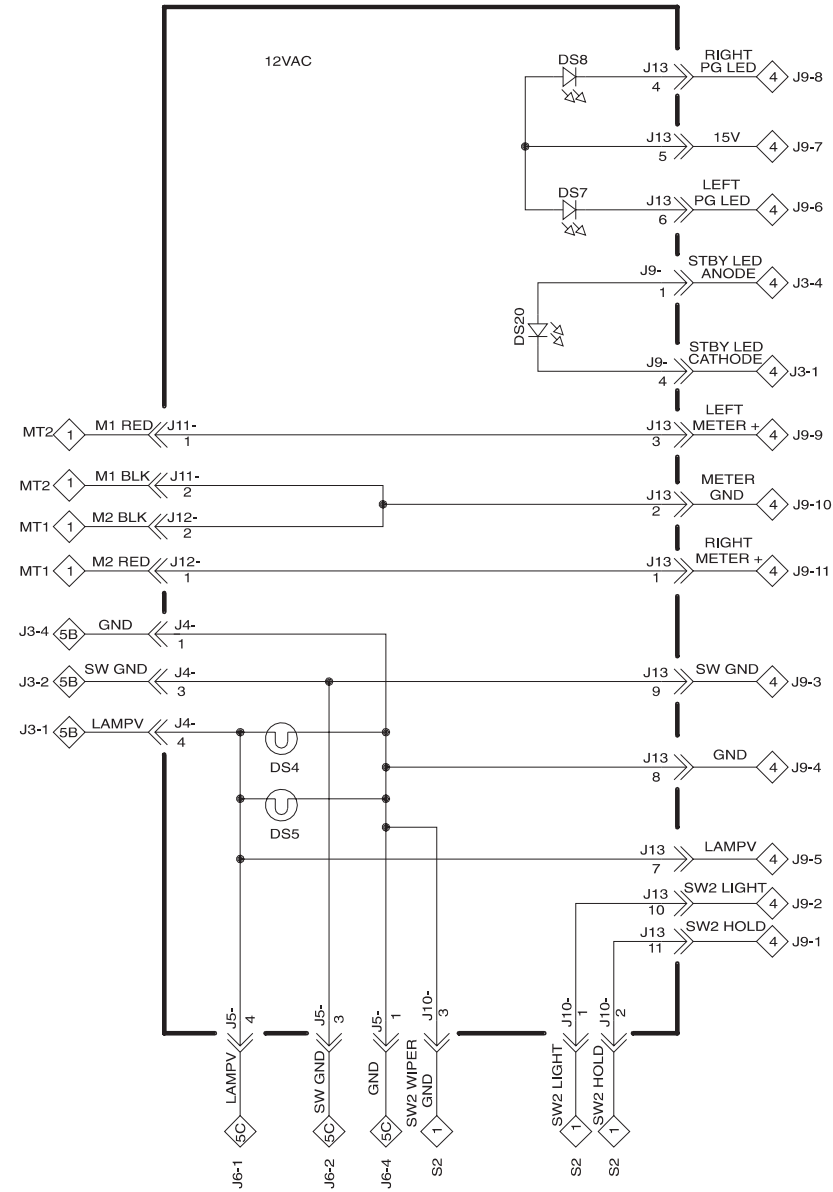

\*DENOTES COMPONENTS ON REVERSE OR BACKSIDE OF PCB BD

**5B** METER LIGHT 049354

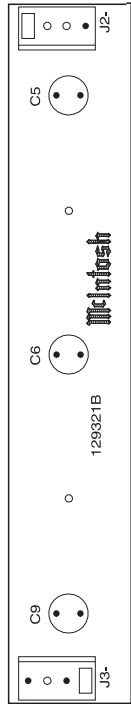
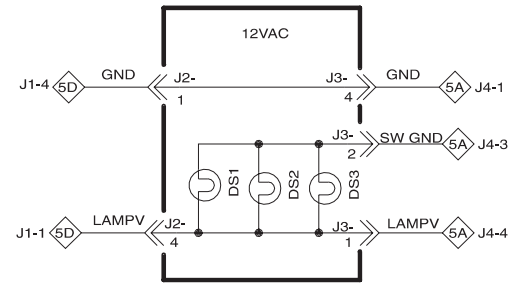

**5D** PANEL LAMP 049354

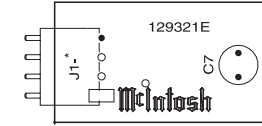
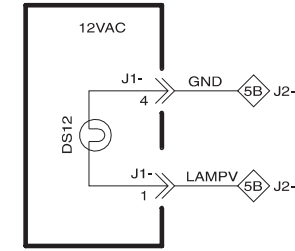

\*DENOTES COMPONENTS ON REVERSE OR BACKSIDE OF PC BD

**5C** METER LIGHT 049354

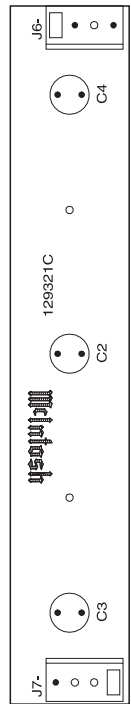
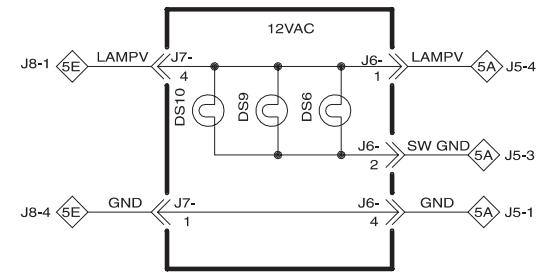

**5E** PANEL LAMP 049354

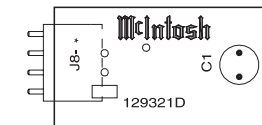
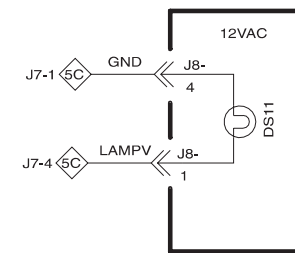

\*DENOTES COMPONENTS ON REVERSE OR BACKSIDE OF PC BD

# PARTS LIST

PART NO DESCRIPTION

REFERENCE NO

## INTERCONNECT

070139 DIODE RECTIFIER  
 089104 FUSE 6.3A 250V SLO BLO  
 124077 METER  
 146243 SWITCH  
 049349 POWER TRANSFORMER  
 049350 OUTPUT TRANSFORMER  
 074091 AC TERM BLOCK

D1  
 F1  
 MT1 MT2  
 S1 S2  
 T1  
 T2  
 TB1

## 049346 HEATSINK PCB

061300 MONO CAP 100PF 100V 5% NPO T&R  
 061304 MONO CAP .01UF 50V 5% X 7R T&R  
 061305 MONO CAP .1UF 50V 5% Z50 T&R  
 064363 CAP POLYPROP 0.15MF 10% 250VDC  
 066446 CAP ELECT 47MF 35V  
 070047 SILICON DIODE 1N4148 T&R  
 070131 DIODE RECTIFIER  
 117213 2-PIN MALE CONNECTOR  
 117217 MALE CONN 7 PIN  
 117404 HEADER 2-PIN 0.156  
 117708 FASTON BLADE W/FEET  
 132171 TRANSISTOR NPN  
 132172 TRANSISTOR SI PNP MPSA55  
 132285 TRANSISTOR NPN 25C3334C  
 132286 TRANSISTOR PNP 2SA32IC  
 134390 TRIM POT 200 OHM 20% HORIZ AD  
 137093 MET OX 680 5% .5W  
 137094 MET OX 1.8K 5% .5W  
 137095 MET OX 430 5% .5W  
 137096 MET OX 47 5% .5W  
 139177 WIREWOUND RES 0.5 OHM 5W 5%  
 144172 RES MF 221 1% 1/4W  
 144279 THERMISTOR 100  
 144378 RES MF 2.21 OHM 1/4W 1%  
 144412 MF RES 15K 1% 1/4W

C7 C8  
 C9 C16  
 C3 C5  
 C10  
 C1 C2  
 D1 D2 D3 D4 D5  
 D6 D7  
 J4-  
 J1  
 J3-  
 J2  
 Q1  
 Q2  
 Q6  
 Q7  
 R13  
 R2 R9  
 R6 R11  
 R7  
 R12  
 R31 R32 R33 R34 R35 R36  
 R1 R8  
 RT1  
 R30  
 R3 R10

## 049353 DRIVER PCB

061249 DISC CAP .47UF 50V MONOLITHIC  
 061298 MONO CAP 22PF 200V 5% NPO T&R  
 061299 MONO CAP 47PF 200V 5% NPO T&R  
 061300 MONO CAP 100PF 100V 5% NPO T&R  
  
 061305 MONO CAP .1UF 50V 5% Z50 T&R  
 064310 CAP MPOLY .0068UF 5% 100/250VDC  
 064363 CAP POLYPROP 0.15MF 10% 250VDC  
 064364 CAP POLYPROP .047MF 10% 250V  
 066446 CAP ELECT 47MF 35V  
 066462 CAP ELECT 10UF 100VDC  
  
 066507 CAP ELECT 220UF 25V  
 117215 4-PIN CONNECTOR  
 117217 MALE CONN 7 PIN  
 117279 11-POS. MALE CONN.  
 117436 PJ261G PHON JACK, GOLD  
 117685 XLR RECEPTACLE FEMALE  
 117759 STEREO 1/8 HEAD PHONE JACK  
 132222 N. CHANNEL FET  
 132223 TRANSISTOR NPN MPS4124 2K/REEL  
  
 132224 TRANSISTOR PNP  
  
 132254 TRANSISTOR NPN

C31 C39  
 C115 C116 C118 C120  
 C117 C119  
 C27 C28 C100 C101 C102  
 C103  
 C32 C33  
 C105 C106  
 C109 C110  
 C107 C108  
 C29 C30  
 C35 C36 C37 C38 C104 C111  
 C112 C113 C114  
 C22 C44  
 J3- J4-  
 J5- J6-  
 J7-  
 J1  
 J2 J8  
 J15 J16  
 Q61 Q62  
 Q6 Q35 Q42 Q44 Q45 Q46  
 Q47 Q49 Q58  
 Q1 Q3 Q19 Q39 Q40 Q43 Q59  
 Q60  
 Q5 Q34 Q52 Q53 Q55 Q56

132255 TRANSISTOR PNP  
 132285 TRANSISTOR NPN 25C3334C  
 132286 TRANSISTOR PNP 2SA32IC  
 133260 DUAL OPERATIONAL AMPLIFIER  
 137042 FLAMEPROOF RES 47 OHM 5% 1/4W  
 139005 WIRE RES 2 OHMS 10% 5W  
 139119 WIRE RES 4 OHMS 5% 5W  
 144053 RES MF 10K 1% 1/4W  
 144086 RES MF 475 1% 1/4W  
 144089 RES MF 806 1% 1/4W  
 144090 RES MF 1K 1% 1/4W  
 144095 RES MF 3.32K 1% 1/4W  
 144097 RES MF 4.75K 1% 1/4W  
 144104 RES MF 20K 1% 1/4W  
  
 144106 RES 33.2K 1% 1/4W  
 144108 RES MF 47.5K 1% 1/4W  
 144112 RES 82.5K 1% 1/4W  
 144118 RES MF 267K 1% 1/4W  
 144154 RES MF 12.1K 1% 1/4W  
 144157 RES MF 10 1% 1/4W  
 144172 RES MF 221 1% 1/4W  
  
 144179 LDR NETWORK VTL5C9  
 144187 RES MF 22.1K 1% 1/4W  
 144196 RES MF 100 1% 1/4W  
 144264 RES MF 10M 1% 1/4W  
 144299 RES MF 2.1K 1% 1/4W  
 144338 RES MF 324 OHM 1% 1/4W  
  
 144364 RES MF 475K 1% 1/4W  
 144406 METAL FILM RES 187K 1% 1/4W  
 148059 SLIDE SWITCH

## 049352 METER PCB

061305 MONO CAP .1UF 50V 5% Z50 T&R  
 064329 CAP M POLY .22UF 5% 63VDC  
 064337 CAP M POLY 1MF 5% 63VDC  
 066390 CAP ELECT 22UF 100V  
 066445 CAP ELECT 10MF 50V  
 066447 CAP ELECT 100MF 16V  
 066504 CAPACITOR ELECT 25000UF 75V  
 066509 CAP ELECT 3300UF 35V  
 070047 SILICON DIODE 1N4148 T&R  
  
 070130 ZENER DIODE 8.2V 1/2W  
 070131 DIODE RECTIFIER  
 087052 RELAY 8A  
 089089 FUSE 2A SLO-BLO 5X20  
 117215 4-PIN CONNECTOR  
 117217 MALE CONN:7 PIN  
 117279 11-POS. MALE CONN.  
 117404 HEADER 2-PIN 0.156  
 117708 FASTON BLADE W/FEET  
 131021 TRIAC 8A 200V  
 131022 600V TRIAC DRIVER OPTOCOUPLER  
 132223 TRANSISTOR NPN MPS4124 2K/REEL  
  
 132224 TRANSISTOR PNP  
 132226 TRANSISTOR P.CHANNEL JUNC.FET  
 133093 IC REGULATOR +5 VOLT

Q2 Q38 Q48 Q50 Q51 Q54  
 Q17 Q21  
 Q18 Q22  
 IC1 IC2  
 R56 R60  
 R177 R179  
 R176 R178  
 R45 R64 R131 R136  
 R164 R171  
 R38 R89 R92 R101  
 R44 R49  
 R41 R55 R96 R98 R133 R165 R166  
 R46 R47 R135 R162  
 R132 R148 R156 R161 R172 R175  
 R182 R183 R184 R185  
 R153 R163  
 R19 R27 R29 R94  
 R154 R155 R167 R168  
 R20 R28 R30 R31 R186  
 R150 R152  
 R67 R68  
 R139 R140 R141 R142 R143 R144  
 R145 R146  
 LD1 LD2  
 R157 R169 R170 R173  
 R48 R61 R130  
 R158 R160  
 R138 R147 R151 R174  
 R36 R51 R53 R76 R97 R99 R134  
 R137  
 R180 R181  
 R37 R52 R75 R91  
 S1

C207 C208 C217 C226 C227  
 C244 C245 C246  
 C241 C242  
 C243  
 C239 C240 C247  
 C216  
 C237 C238  
 C235 C236  
 D3 D4 D5 D6 D7 D8 D9 D10 D12  
 D12 D13 D14 D20  
 D1  
 D15 D16 D17  
 R1  
 F1  
 J3-  
 J2-  
 J1- J9-  
 J21- J22-  
 J14 J15 J26- J27 J28 J31 J41 J42 J50  
 Q9  
 Q8  
 Q10 Q13 Q14 Q16 Q17 Q18 Q20 Q21  
 Q22 Q23 Q24  
 Q11  
 Q12  
 Q3

133192 IC NAND SCHMIT 2-IN X 4  
 133260 DUAL OPERATIONAL AMPLIFIER  
 134383 TRIM POT 100K OHM 20%  
 139079 WIRE RES 1.5K 10% 5W  
 139218 2.7 OHM 2W 5% WW RESISTOR FP  
 144081 RES MF 68.1K 1% 1/4W  
 144091 RES MF 1.1K 1% 1/4W  
 144106 RES 33.2K 1% 1/4W  
 144120 RES MF 402K 1% 1/4W  
 144128 RES MF 1.5K 1% 1/4W  
 144130 RES MF 10.2K 1% 1/4W  
 144157 RES MF 10 1% 1/4W  
 144187 RES MF 22.1K 1% 1/4W  
 144191 RES MF 1.21K 1% 1/4W  
 144196 RES MF 100 1% 1/4W  
 144265 RES MF 2.21M 1/4W  
 144379 RES METAL FILM 4.75M 1/4W 1%  
 144406 METAL FILM RES 187K 1% 1/4W  
 144418 MF RES 121K 1% 1/4W  
 144421 MF RES 221K 1% 1/4W  
 144422 MF RES 1.5M 1% 1/4W  
 178159 FUSE HOLDER 5X20MM PCB MOUNT

IC4  
 IC2 IC3  
 R195 R196  
 R198  
 R197  
 R152 R192  
 R2 R3 R167 R172 R191  
 R165 R166  
 R199  
 R164  
 R171 R189 R190 R194  
 R138  
 R177 R184  
 R180 R187  
 R175 R181 R186  
 R178 R182  
 R183 R188  
 R4 R5 R179 R185  
 R170 R173  
 R193  
 R174 R200  
 F1

## 049354 POWER GUARD LIGHT\METER LIGHT\PANEL LAMP PCB

058120 LAMP 14V #7373  
  
 058133 AMBER LED  
 058148 RED LED HIGH EFFICIENCY  
 117221 MALE CONN 3 POS RT. ANGLE  
 117240 4 PIN RT. ANGLE  
 117242 11 POS. RT ANGLE  
 117274 CONN. 2 POS. R-ANGLE

C1 C2 C3 C4 C5 C6 C9 C10  
 C11 C12  
 DS7 DS8  
 DS20  
 J10-  
 J1- J2- J3- J4- J5-J6- J7- J8- J9-  
 J13  
 J11- J12-

# EXPLODED VIEW

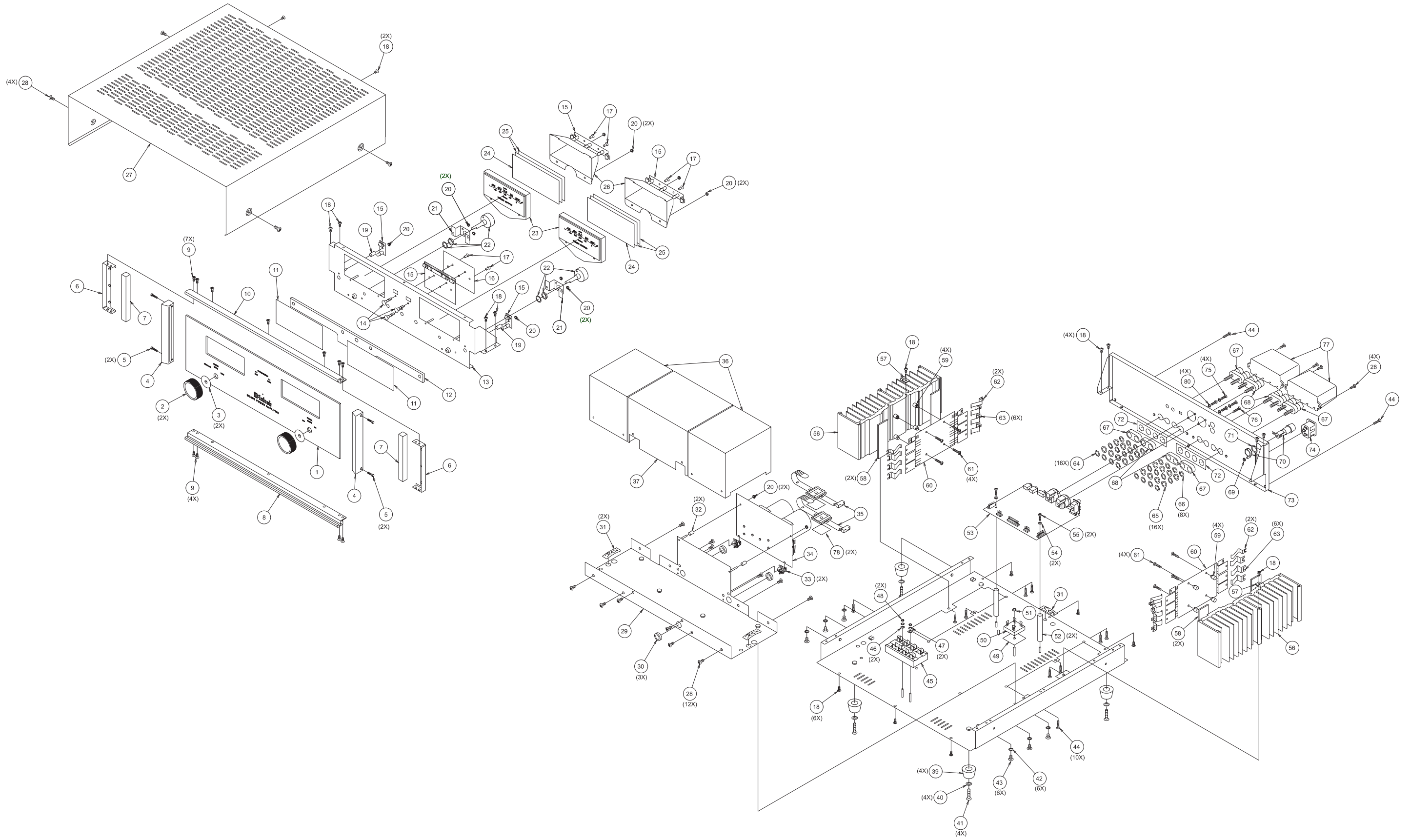

# EXPLODED VIEW PARTS LIST

Ref No.	Part No.	Description
1	016411	GLASS PANEL
2	049320	KNOB ASSEMBLY
3	104017	BLK FELT WASHER
4	018611	5" ENDCAP
5	101042	TS 4-40 X 1/2 SLOT FILLISTER
6	004810	EXTRUSION BRACKET 5"
7	094360	FOAM TAPE 1/2 X 1/2
8	018588	BOTTOM EXTRUSION
9	101172	TCS 6-32 X 1/4 PHIL FLAT U/C
10	018587	TOP EXTRUSION
11	017363	PLEXIGLAS FILTER LIGHT BLUE
12	017711	DISPLAY PLEXIGLAS
13	004804	SUBPANEL
14	112092	REVERSE LOCKING PCB SUPPORT
15	049354	LAMP PCB ASSY
16	022315	FISHPAPER SHIELD
17	114072	PLASTIC RIVET
18	101054	TS 6-32 X 1/4 PH PAN TAPTITE BLK
19	112086	NYLON SPACER
20	102001	KEP NUT 4-40 CADMIUM PLATE
21	004805	SWITCH BRACKET
22	146243	POWER SWITCH
23	124077	METER
24	092341	FILTER AZURE BLUE
25	092342	FILTER PALE BLUE
26	017447	PLASTIC LIGHT BOX
27	004809	TOP COVER
28	101078	TS 8-32 X 5/16 PHIL PAN BLK
29	005023	TRAY
30	078003	RUBBER GROMMET
31	106007	SPRING CLIP: LATCH TYPE
32	112038	STL SPACER 4 X 3/8 NICKEL PLT
33	112104	BOARD MOUNT
34	049352	POWER SUPPLY METER PCB ASSY
35	112102	MOUNTING STRAPS
36	049350	OUTPUT TRANSFORMER
37	049349	POWER TRANSFORMER
38	005024	CHASSIS
39	017218	PLASTIC FEET-BLACK
40	104063	FLAT WASHER #10 CLEAR ZINC
41	100159	MS 10-32 X 3/4 PHIL PAN BLK ZINC
42	104067	LK WASH: INTERNAL STAR #10
43	100120	MS 10-32 X 1/4 PHIL PAN ZINC
44	101176	TCS 6-32 X 1/2 PH PAN BLK TYPE F
45	074091	AC TERMINAL BLOCK
46	104001	FLAT STEEL WASHER #4 X 9/32 X .025
47	104004	LK WASHER 5 X .255 INT STAR
48	102022	MN 4-40 3/16 X 3/16
49	084135	THERMAL PAD
50	070139	RECTIFIER BRIDGE
51	102003	MACH NUT 6-32 W/LOCK
52	112103	HEX SPACER 6-32 X 2.375
53	049353	DRIVER PCB ASSY
54	104005	STEEL WASHER: FLAT 6 X 3/8 X .032
55	100255	SEMS 6-32 X 3/8 PHIL PAN INTERNAL
56	018617	AMPLIFIER HEATSINK
57	017160	MOUNTING TAB W/ .140 DIA MTG
58	084187	ISOSTRATE
59	112087	PCB SPACER 1/4"
60	049346	HEATSINK PCB ASSY
61	101059	SM 6 X 5/8 PHIL PAN TYPE A
62	114118	TRANSISTOR CLIP 218
63	114119	TRANSISTOR CLIP 214
64	110009	NUT M5 X 0.8 BRASS WITH GOLD PLATE
65	104130	LK #10 SPLIT PHOS/BRONZE
66	104148	FLAT WASHER BRASS
67	084189	DUAL BINDING POST RED
68	084124	DUAL BINDING POST
69	102020	MACH NUT 6-32 SELF-LOCK
70	178161	FUSE HOLDER 5 X 20mm IEC
71	104016	LK WASH: 1/2 X .630 X .022 INT STAR
72	004800	OUTPUT PLATE
73	005022	REAR PANEL
74	117487	AC LINE RECEPTACLE
75	101197	HI/LO 4-24 X 3/8 PHIL ROUND BLACK
76	101114	SM 4-24 X 1/2 PHIL PAN TYPE A
77	017706	TERMINAL COVER
78	094332	DOUBLE COATED MTG TAPE 1/8" THICK
79	078017	GROMMET 3/4 X 9/16
80	104142	LOCKWASHER 2.5mm INT STAR ZINC

# REPACKING INSTRUCTIONS

In the event it is necessary to repack the unit for shipment, the unit must be packed exactly as shown below.

**IMPORTANT** - The four plastic feet must be attached to the bottom of the unit so they will locate in the four holes of the bottom pad. Three #10 x 2-1/4" screws and washers must be used to fasten the unit securely to the bottom pad and wood skid. Failure to do this will result in shipping damage.

If a shipping carton or any of the interior parts is needed, please call or write the Customer Service Department of McIntosh Laboratory. Order parts from the accompanying list by part number.

Use the original shipping carton and interior parts only if they are in good serviceable condition.

Qty.	Part No.	Description
1	033838	Shipping carton only
4	033837	End cap (Foam pad)
1	033836	Inside carton only
1	033725	Top pad
1	034008	Bottom pad
3	017218	Plastic foot (spacer)
1	033699	Wood skid
3	101169	#10 x 2-1/4" Wood screw
3	104033	#10 x 1-3/4" Flat washer
4	017218	Plastic foot
4	100159	#10-32 x 3/4" Machine screw
4	104083	#10 x 7/16" Flat washer
1	049107	Packaging complete

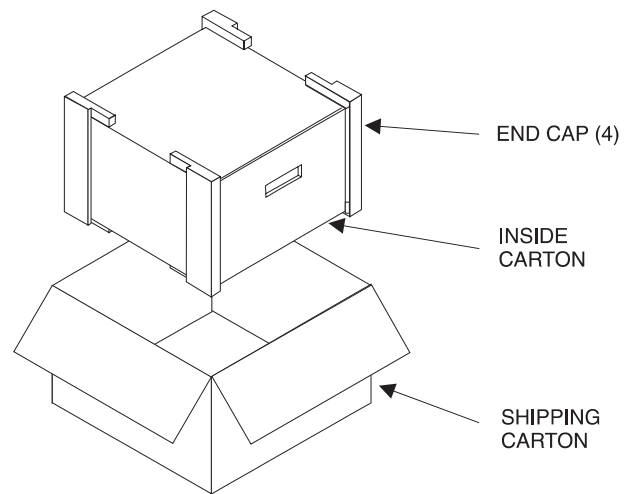
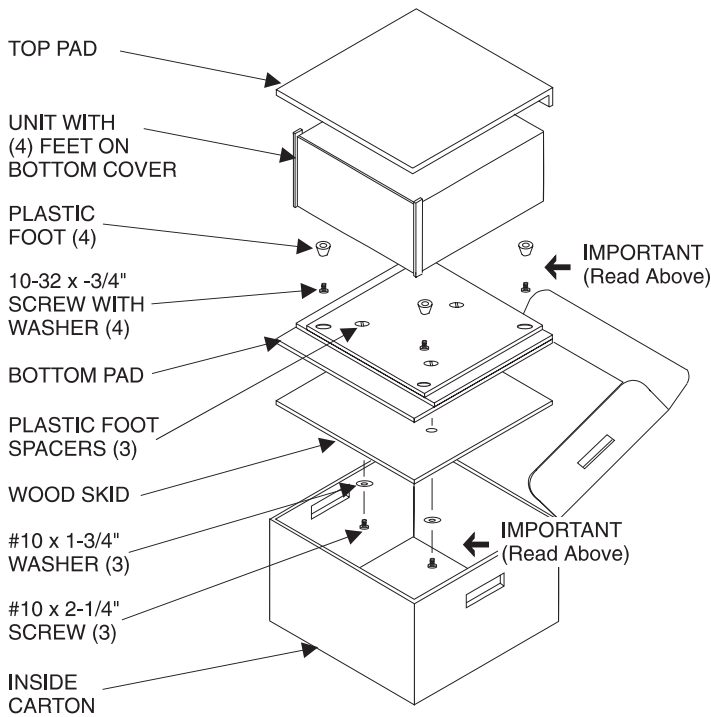

# MC202

## POWER AMPLIFIER

# SERVICE MANUAL

The continuous improvement of its products is the policy of McIntosh Laboratory Incorporated, who reserve the right to improve design without notice. Because of the constant upgrading of McIntosh products' circuitry and components, the Company cannot insure, and does not warrant, the accuracy of the within schematic material, which is intended for information only.