

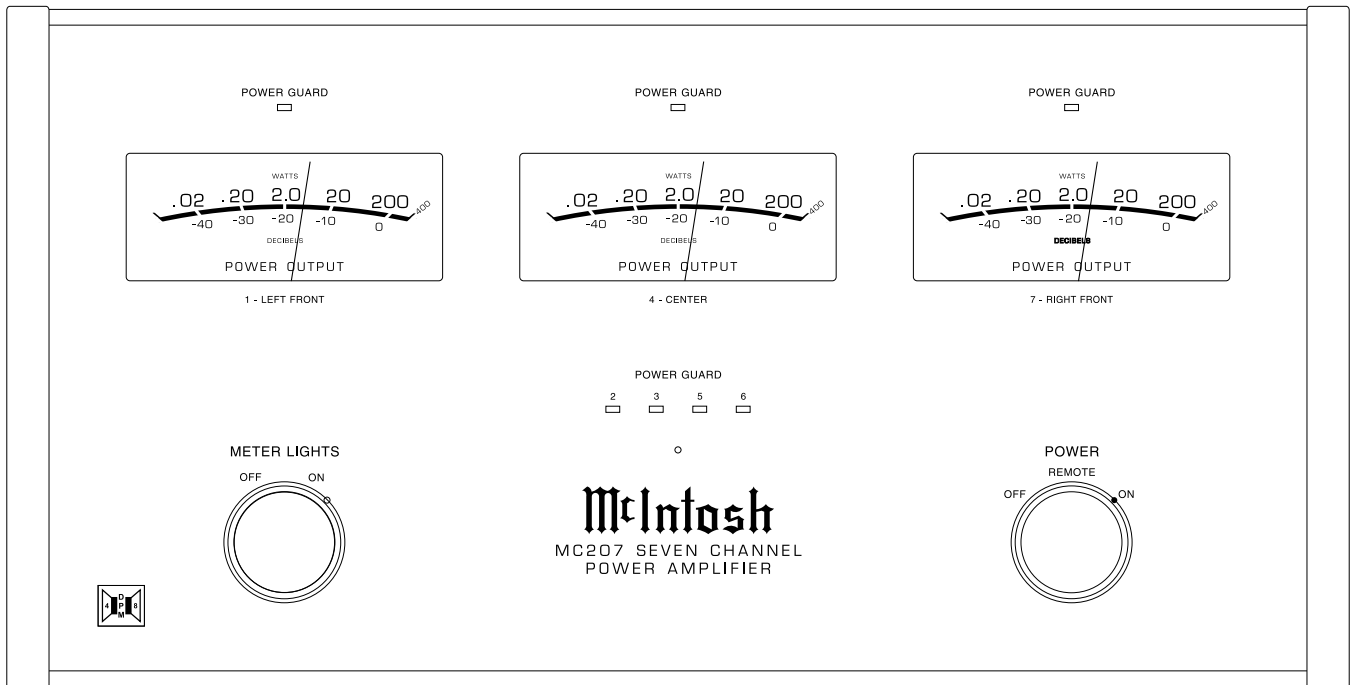

# MC207

## POWER AMPLIFIER

SERIAL NO. VQ1001 And Above



### CONTENTS

Performance Specifications .....	2	Heatsink 2-Channel Schematic and PCB .....	21 - 26
Notes .....	2	Display Schematic and PCB .....	29 - 32
Rear Panel .....	3	Capacitor Schematic and PCB .....	33
Section Location .....	5	Power Supply Schematic and PCB .....	34 - 35
Block Diagram .....	6	Parts List .....	36 - 42
Interconnection Diagram .....	7 - 8	Exploded Views and Parts Lists .....	43 - 46
Input Schematic and PCB .....	9 - 12	Repacking Instruction .....	47
Heatsink 1-Channel Schematic and PCB .....	13 - 18		

# SERVICE MANUAL

Serial Number VQ1001 And Above

# PERFORMANCE SPECIFICATIONS

## Power Output

Minimum sine wave continuous average power output per channel, all channels operating is: 200 watts into 4 ohm or 8 ohm load

## Rated Power Band

20Hz to 20,000Hz

## Total Harmonic Distortion

Maximum Total Harmonic Distortion at any power level from 250 milliwatts to rated power output is: 0.005% for 4 or 8 ohm loads

## Dynamic Headroom

1.7dB

## Frequency Response

+0, -0.25dB from 20Hz to 20,000Hz  
+0, -3dB from 10Hz to 100,000Hz

## Sensitivity

1.0 Volt Unbalanced with a 4 ohm Loudspeaker  
2.0 Volt Balanced with a 4 ohm Loudspeaker  
1.4 Volt Unbalanced with a 8 ohm Loudspeaker  
2.8 Volt Balanced with a 8 ohm Loudspeaker

## A-Weighted Signal To Noise Ratio

89dB (112dB below rated output)

## Intermodulation Distortion

Maximum Intermodulation Distortion if instantaneous peak output per channel does not exceed twice the rated output, for any combination of frequencies from 20Hz to 20,000Hz, with all channels operating is: 0.005% for 4 or 8 ohm loads

## Input Impedance

20,000 ohms Balanced  
10,000 ohms Unbalanced

## Wide Band Damping Factor

Greater than 60 at 4 ohms  
Greater than 140 at 8 ohms

## Power Requirements

100 Volts, 50/60Hz at 1440 watts  
110 Volts, 50/60Hz at 13.0 amps  
120 Volts, 50/60Hz at 12.0 amps  
220 Volts, 50/60Hz at 6.0 amps  
230 Volts, 50/60Hz at 6.0 amps  
240 Volts, 50/60Hz at 6.0 amps

*Note: Refer to the rear panel of the MC207 for the correct voltage.*

## Dimensions

Front Panel: 17-1/2 inches (44.45cm) wide, 9-7/16 inches (23.97cm) high. Depth behind front mounting panel is 18-3/4 inches (47.63cm), including clearance for connectors.

## Weight

83 pounds (37.6kg) net, 116 pounds (52.6kg) in shipping carton

# NOTES

1. The heavy lines on the schematic denote the primary signal path.
2. Unless otherwise noted, all voltages indicated on the schematics are measured under the following conditions:
  - a. AC input at 120 volts, 50/60Hz.
  - b. All voltages are +/-10% with respect to ground. A high impedance (10 megaohm) voltmeter must be used.
3. Unless otherwise specified:
  - a. Resistor values are in ohms.
  - b. Capacitor values are microfarads (uF).
  - c. Inductor values are in microhenries (uH).
4. On PC board drawings, Square pad indicates:
  - a. Polarized Capacitors - Positive
  - b. Diodes - Cathode
  - c. Others - Pin 1
5. **WARNING**  
Parts marked with the symbol  have critical characteristics. Use only replacement parts recommended by the manufacturer.

# REAR PANEL

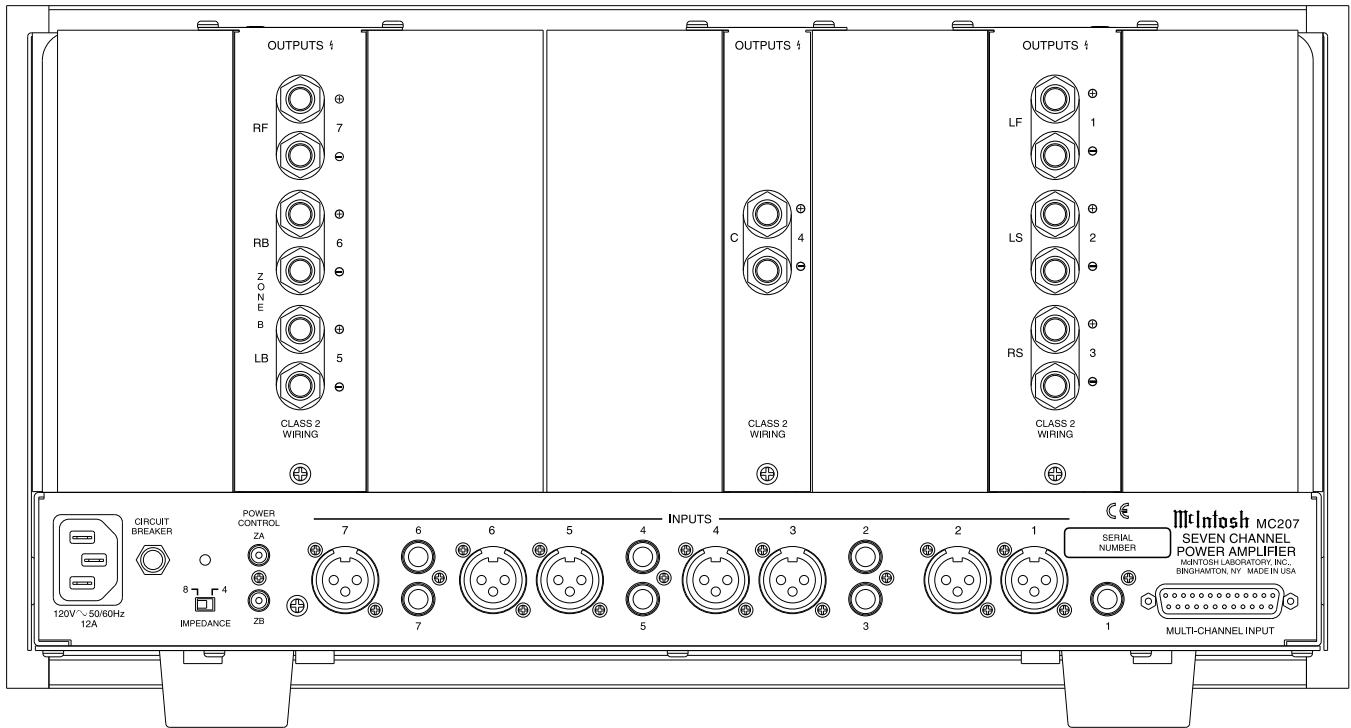

# *NOTES*

# SECTION LOCATIONS

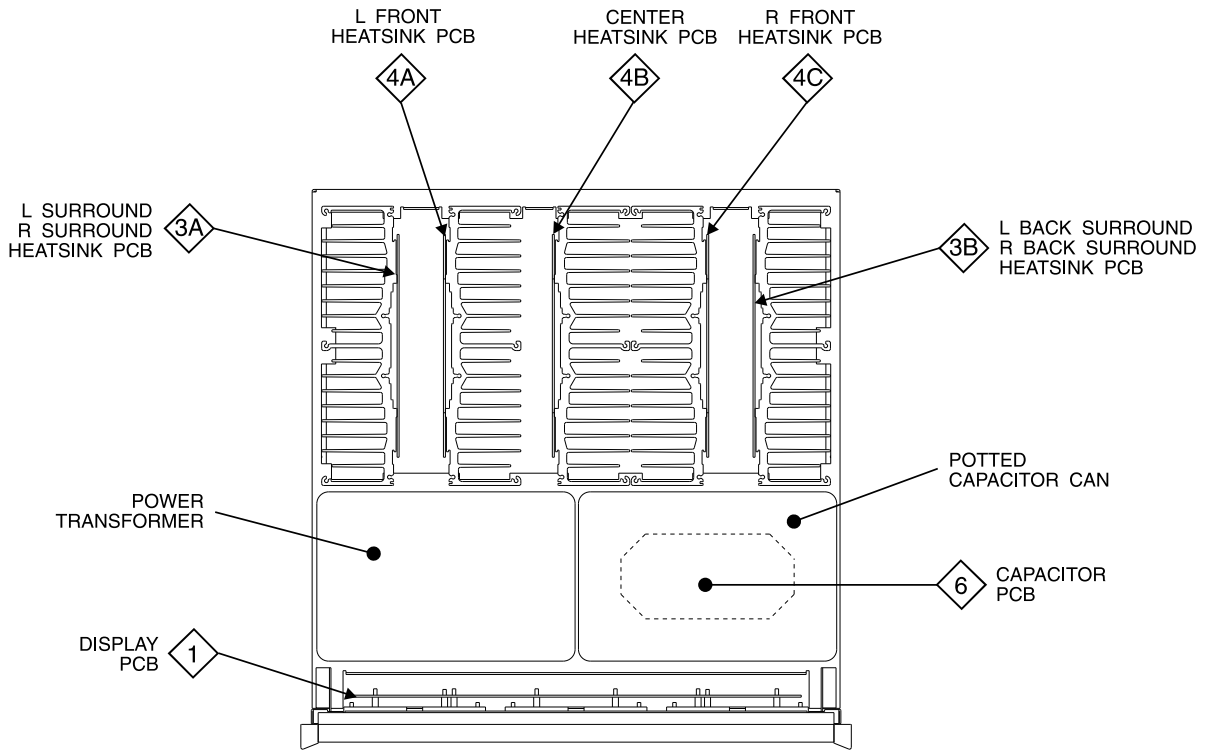

TOP VIEW

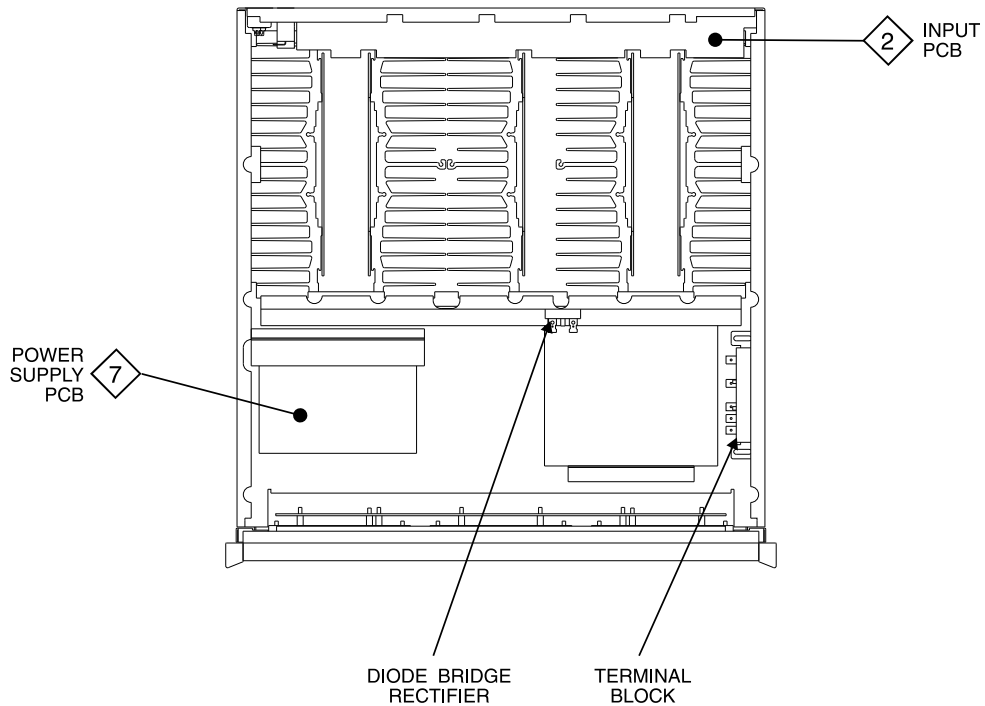

TOP VIEW WITH COVER REMOVED

# BLOCK DIAGRAM

One Channel Shown

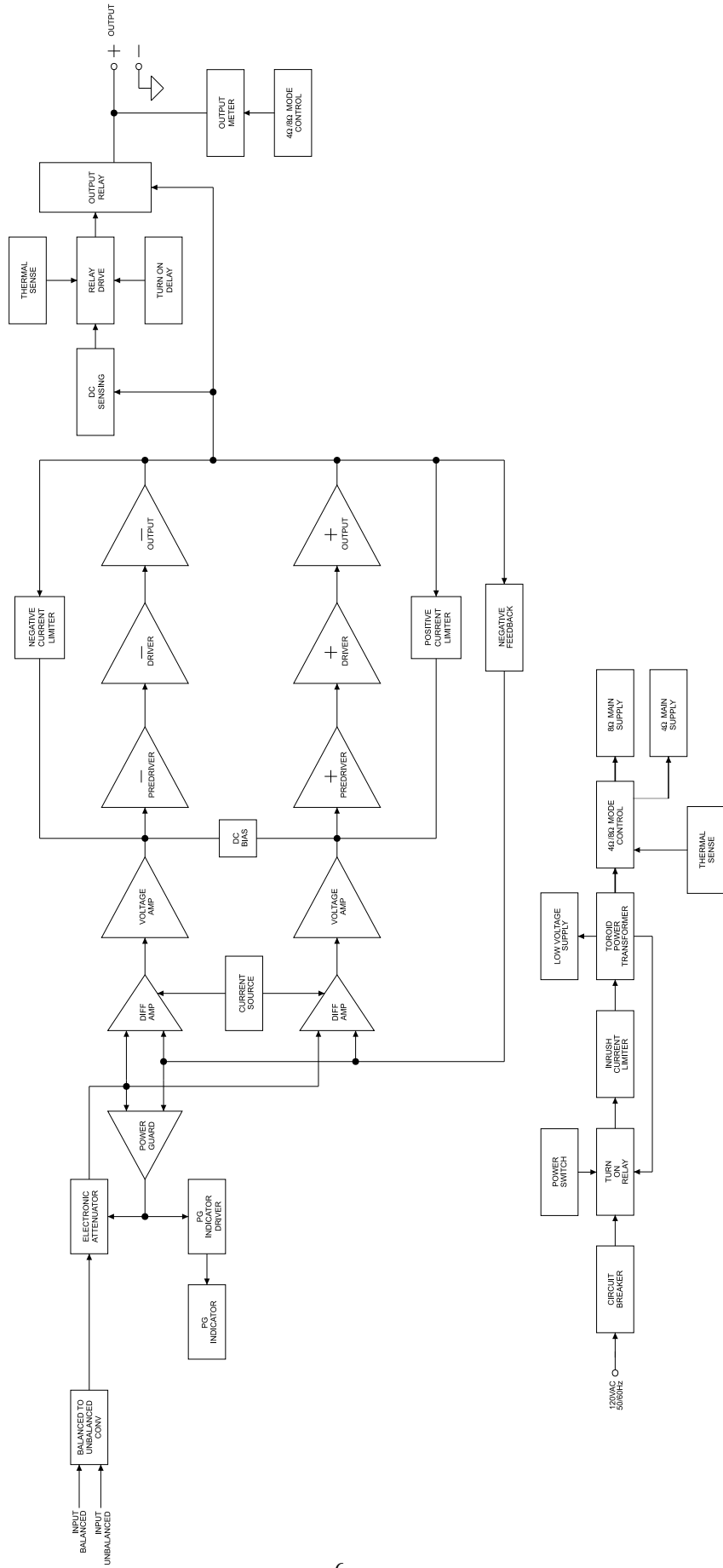

# 1 INTERCONNECT

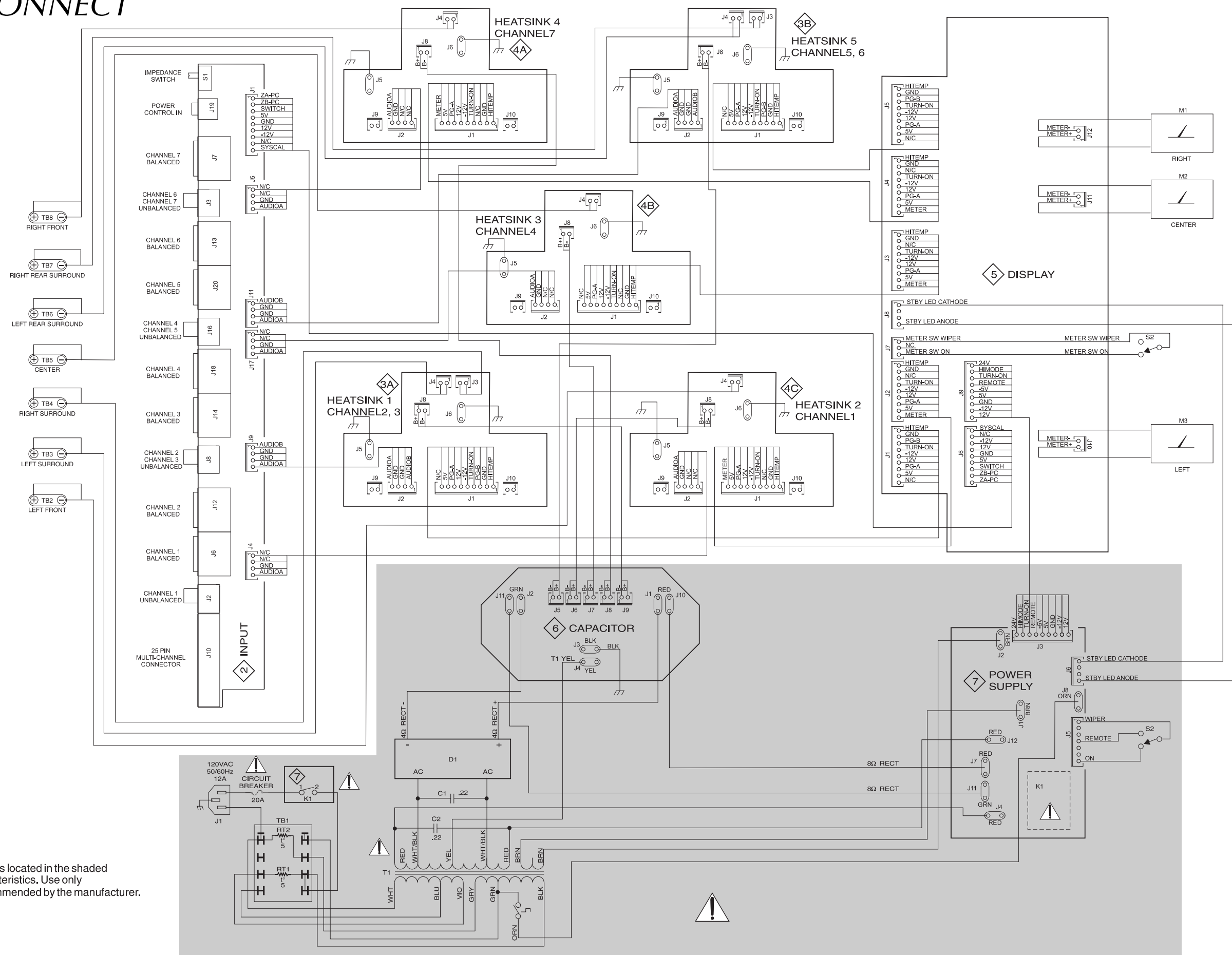

**WARNING** Parts located in the shaded area have critical characteristics. Use only replacement parts recommended by the manufacturer.

# 2 INPUT 050065

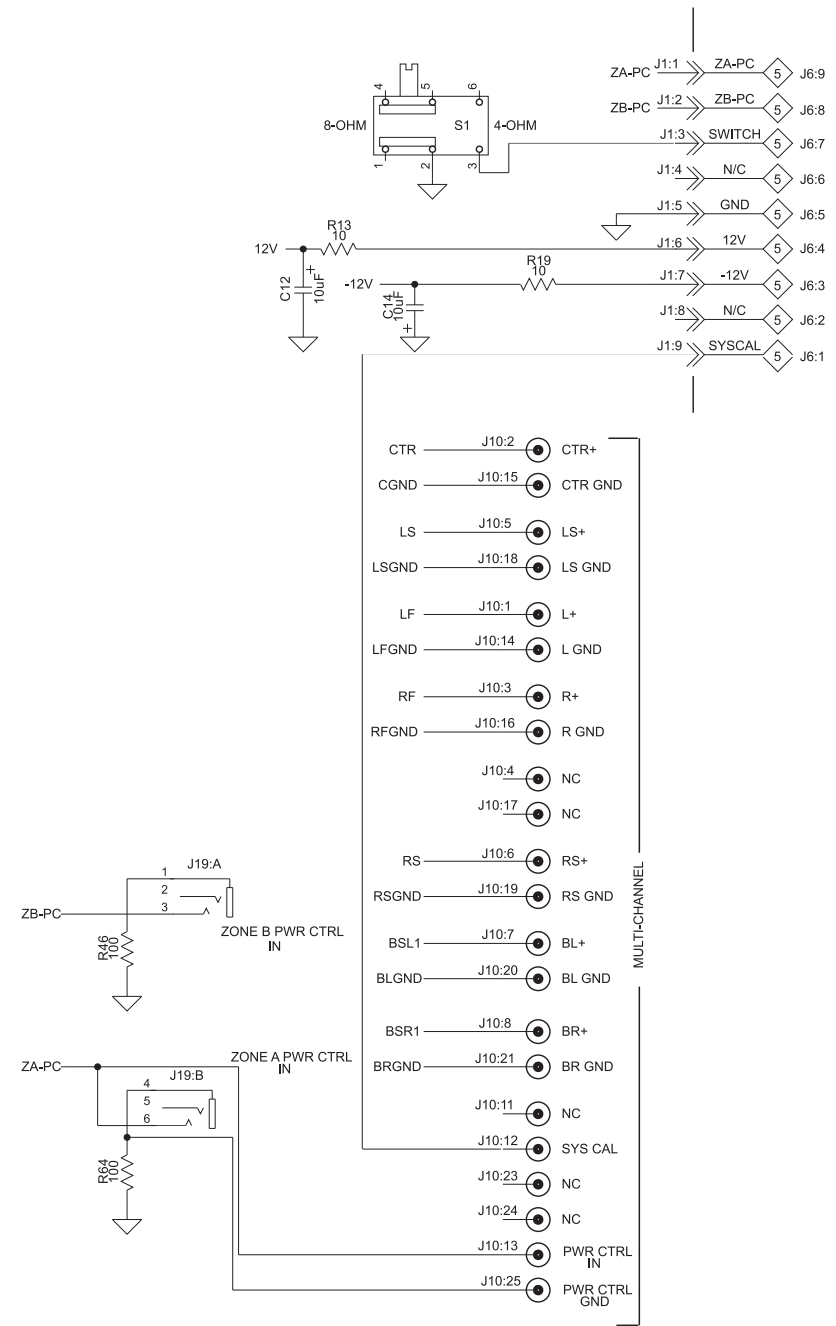
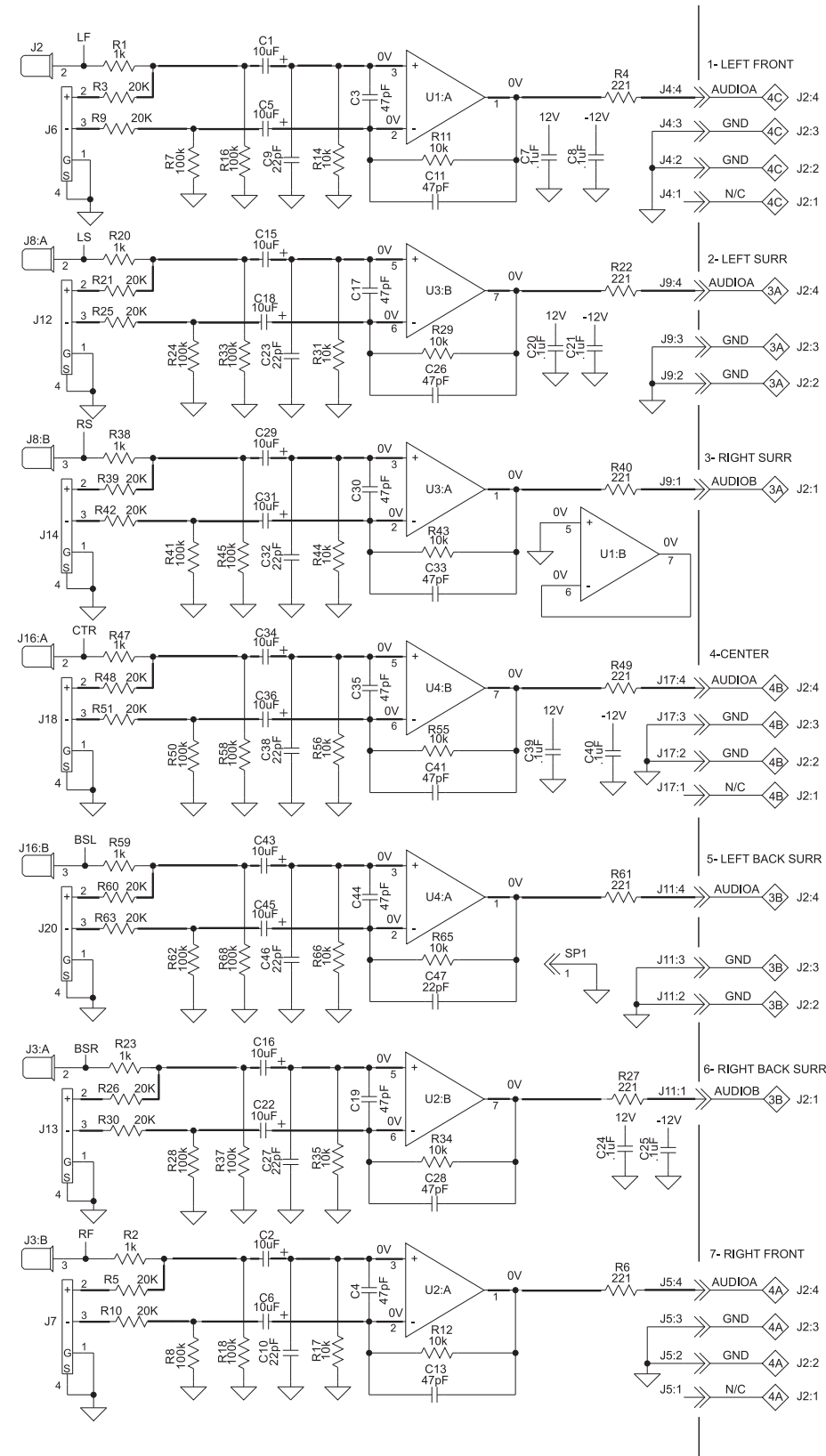

POWER TABLE			
REF DES	DGND	-12V	12V
S1	10 9 8 7		
U1		4	8
U2		4	8
U3		4	8
U4		4	8



2 INPUT 050065

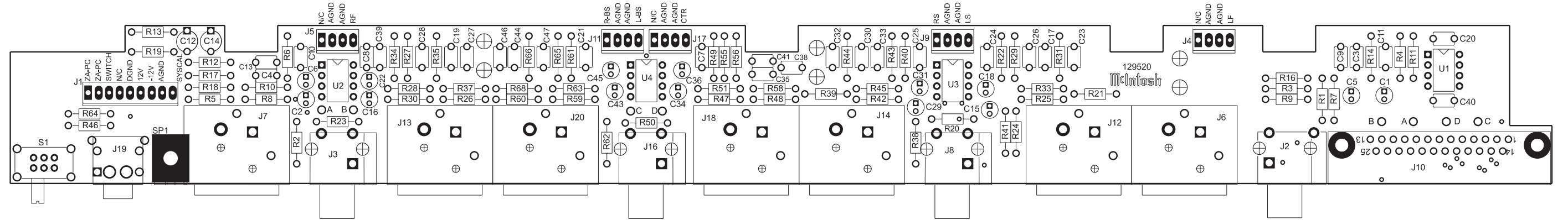

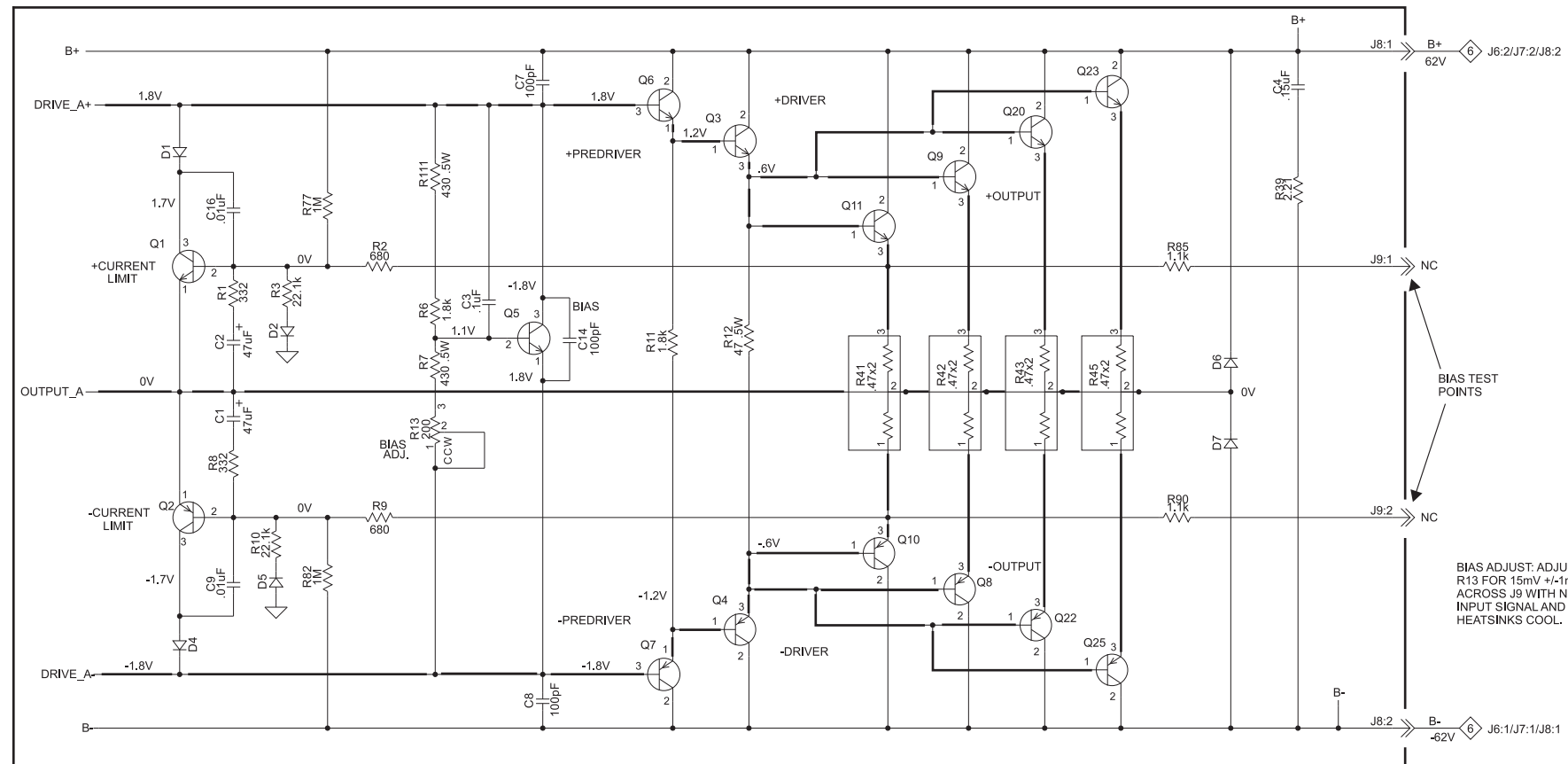



# HEATSINK 1-CHANNEL DRIVER SECTION 050070

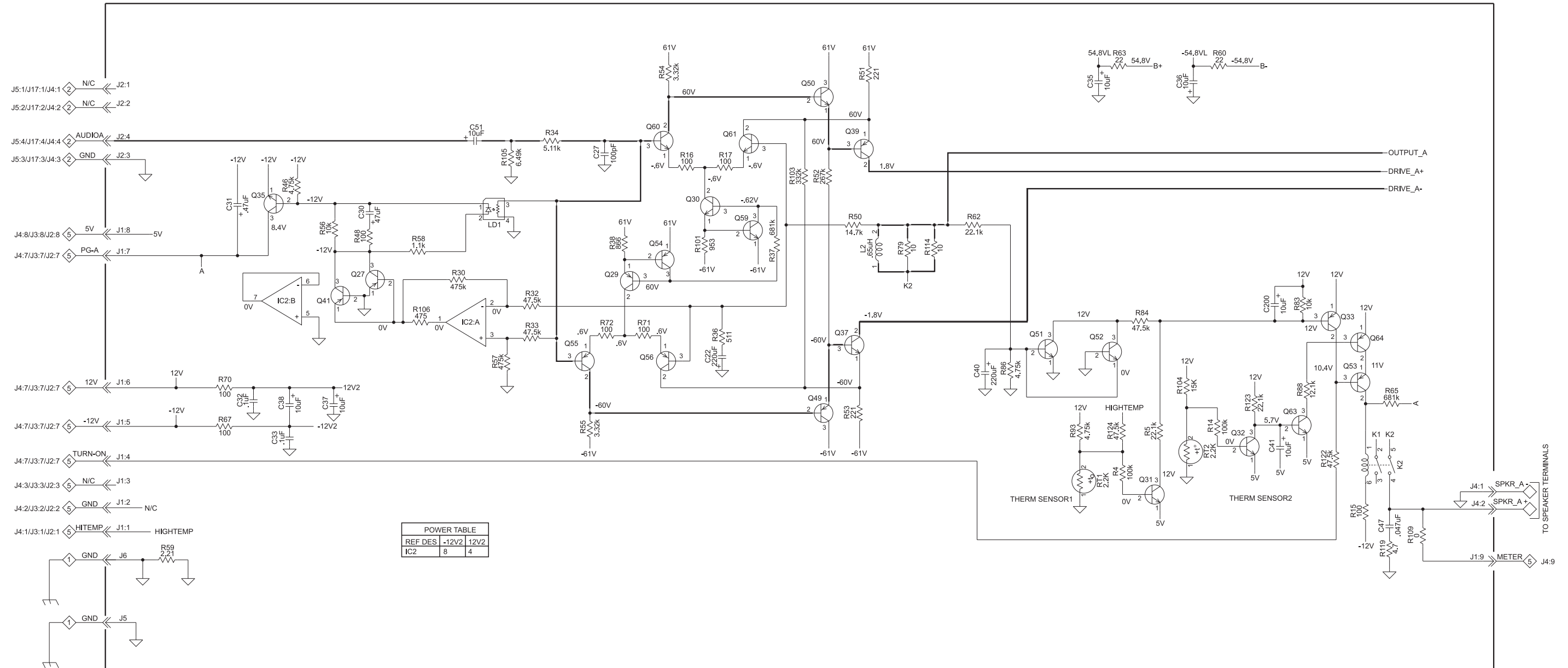

**NOTE:**  
 .125" SPACING IS  
 CRITICAL WHEN  
 REPLACING  
 TRANSISTORS.

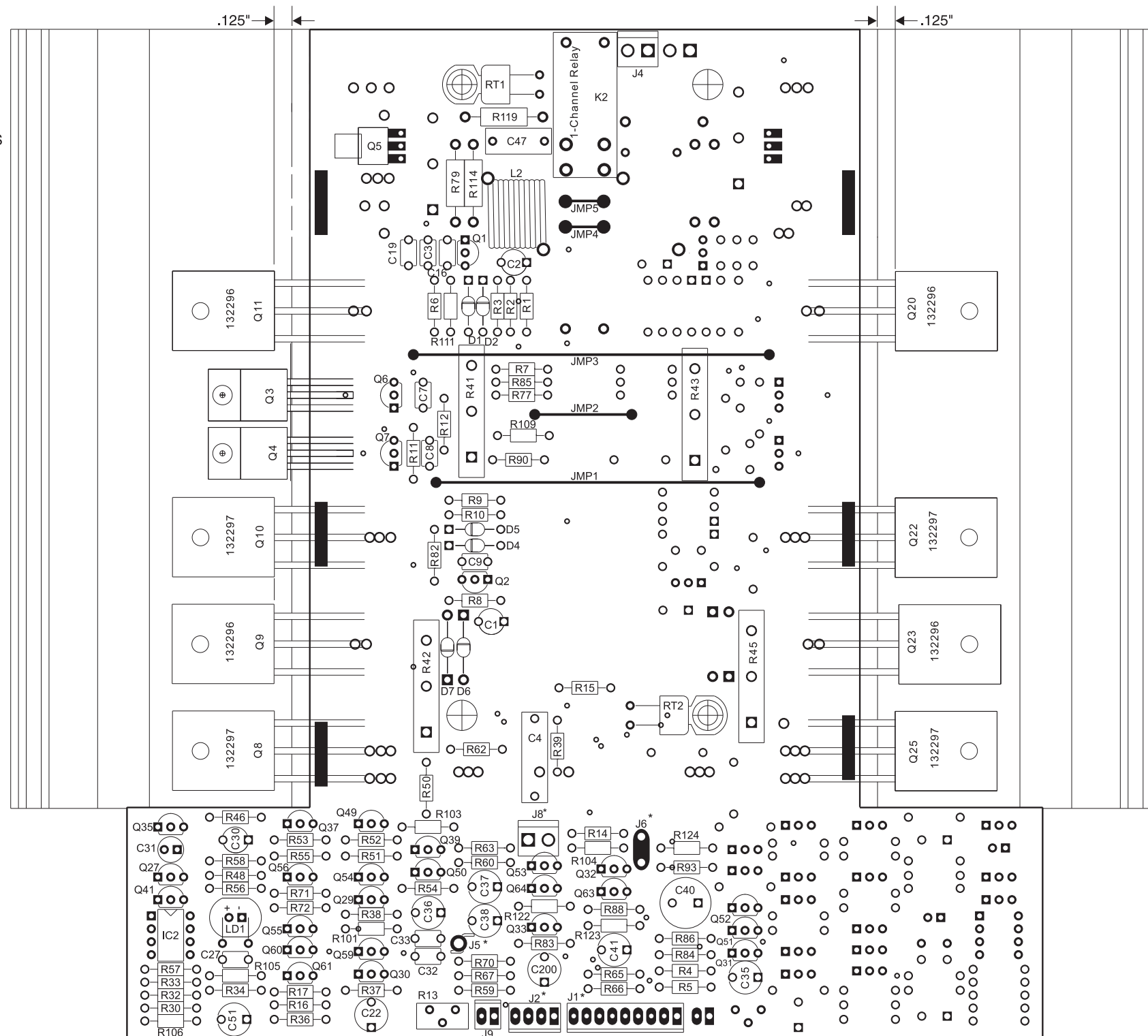

\* Denotes components on reverse or backside of PC Board.

*NOTES*

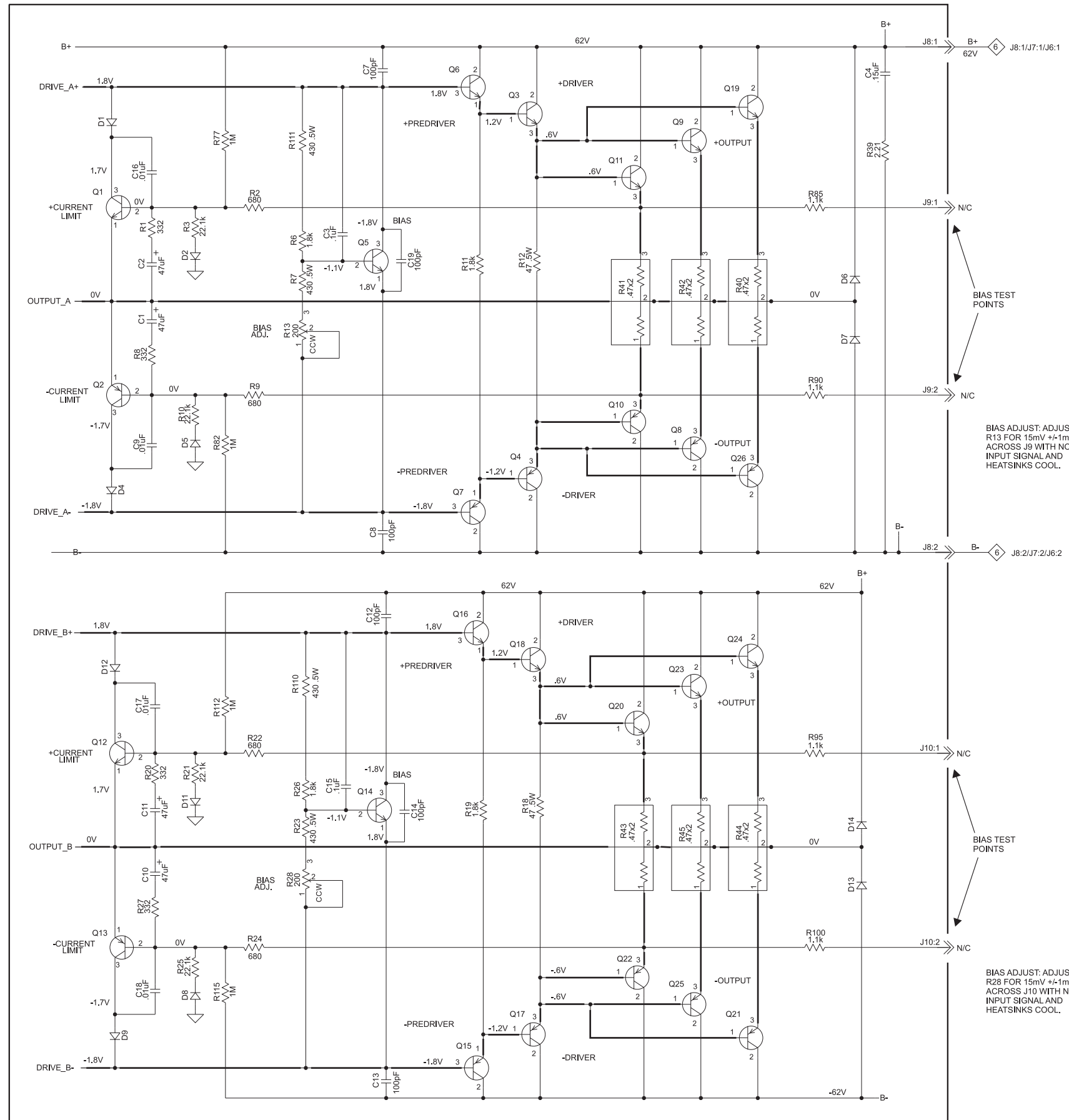

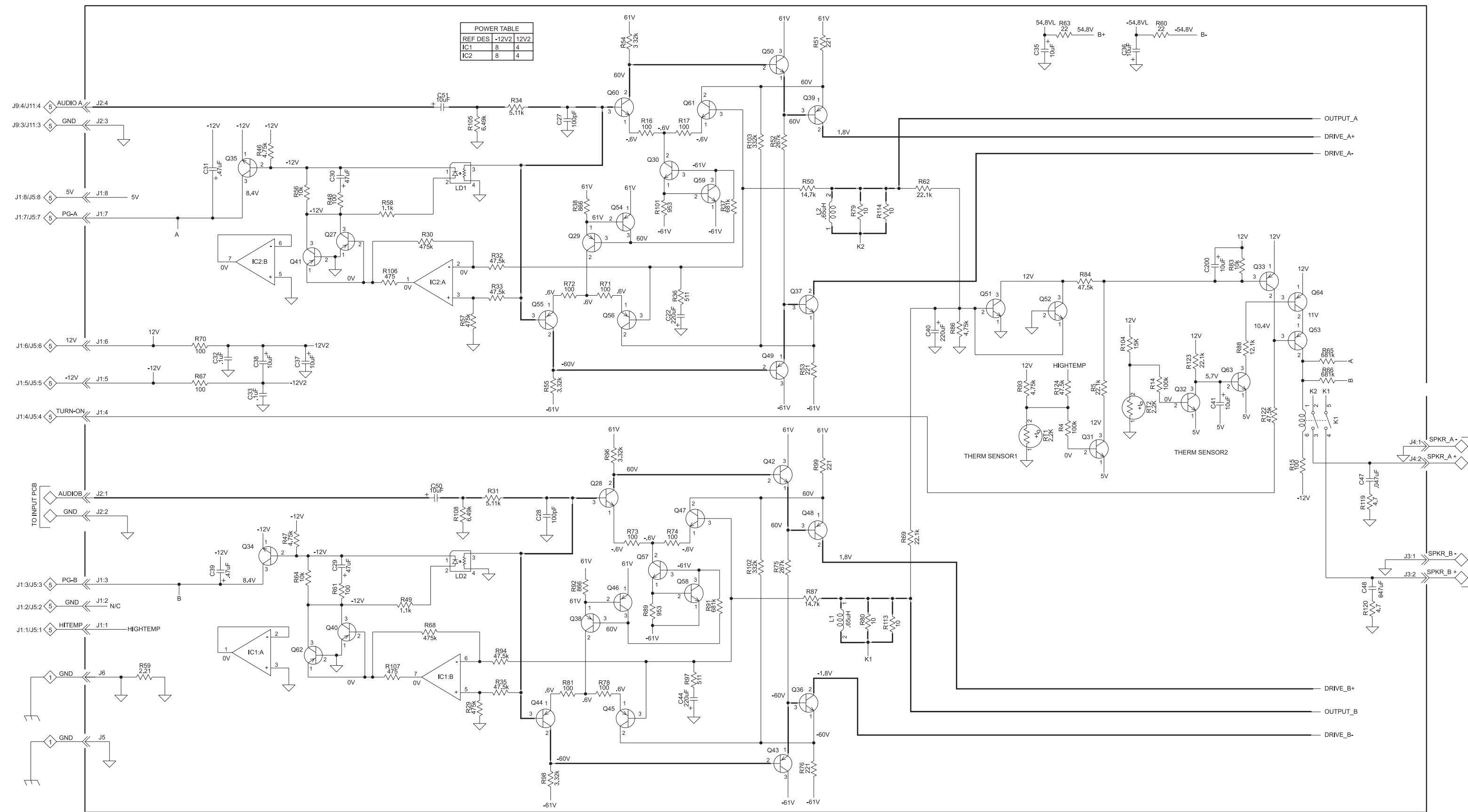

NOTE:  
.125" SPACING IS  
CRITICAL WHEN  
REPLACING  
TRANSISTORS.

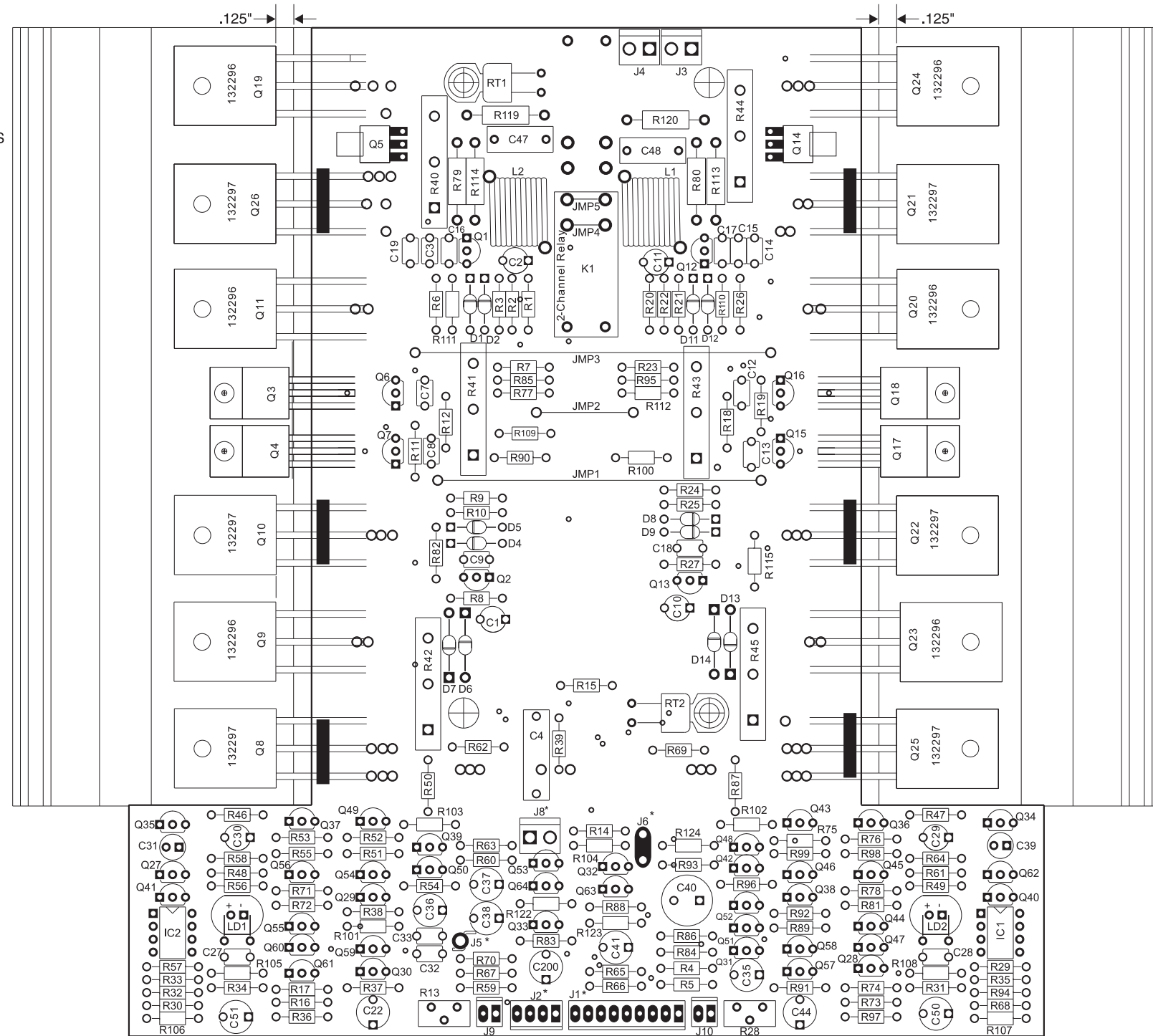

\* Denotes components on reverse or backside of PC Board.

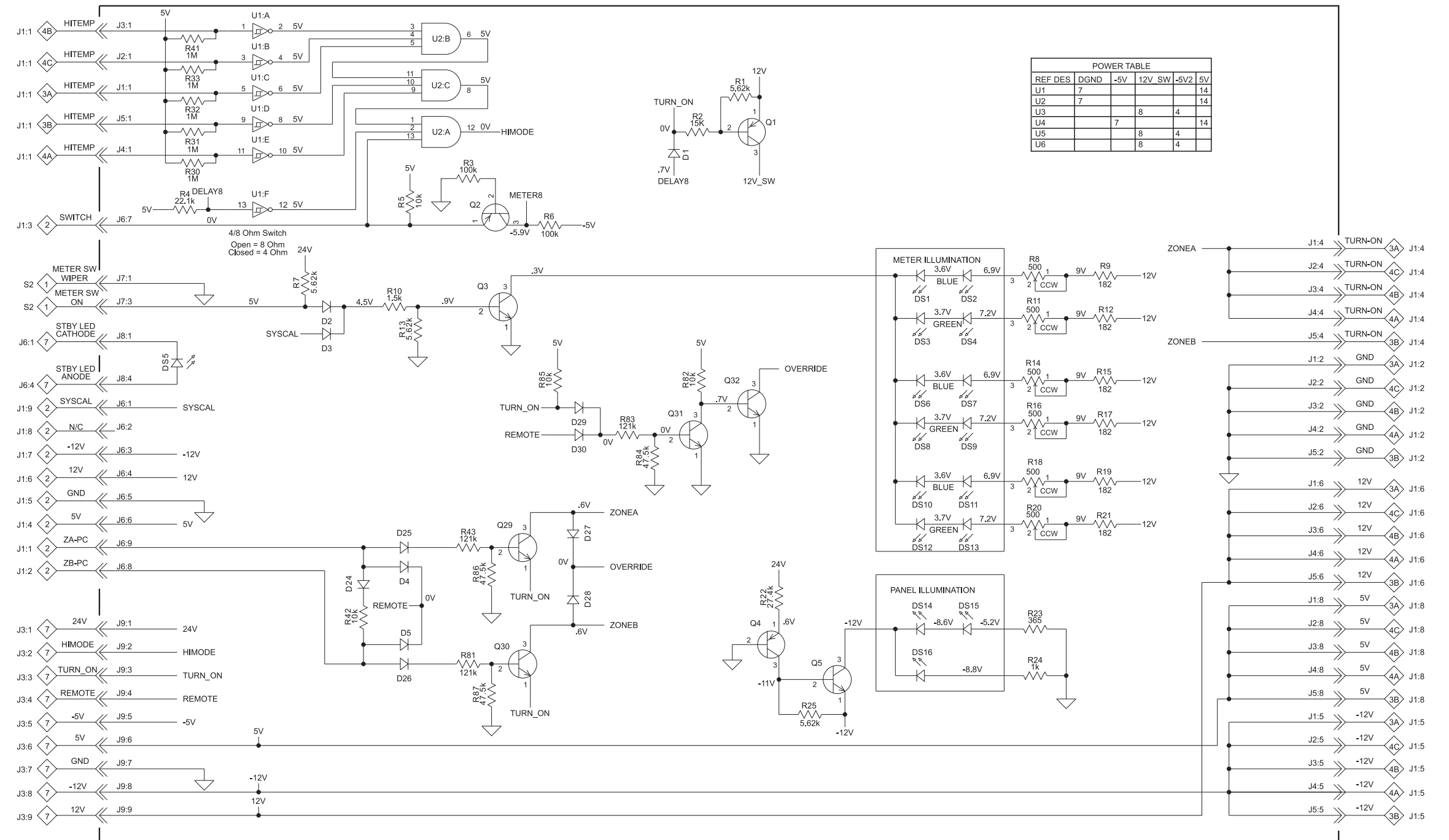



**5** DISPLAY METER SECTION 050066

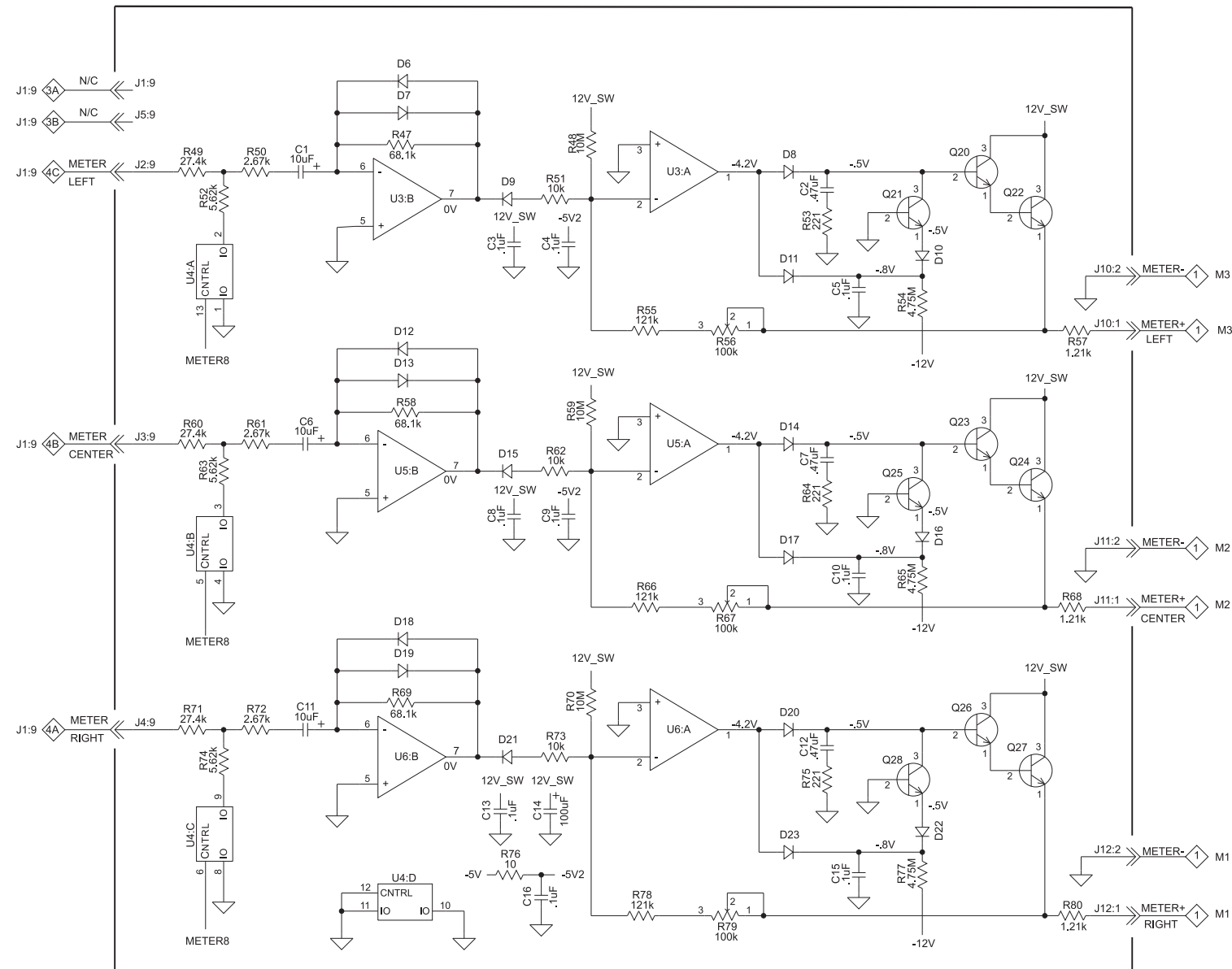

**5** DISPLAY POWER GUARD SECTION 050066

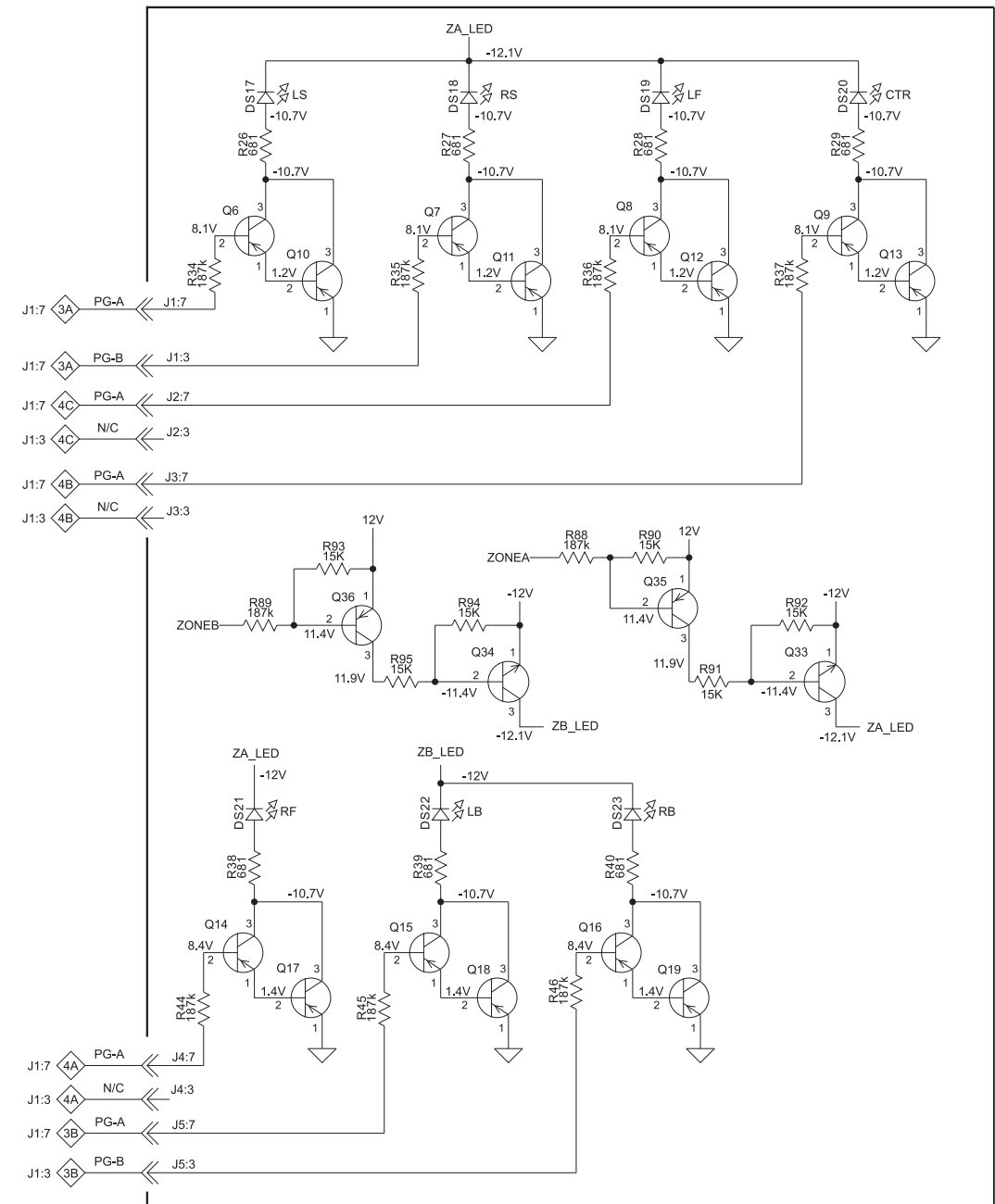

**5** *DISPLAY* 050066

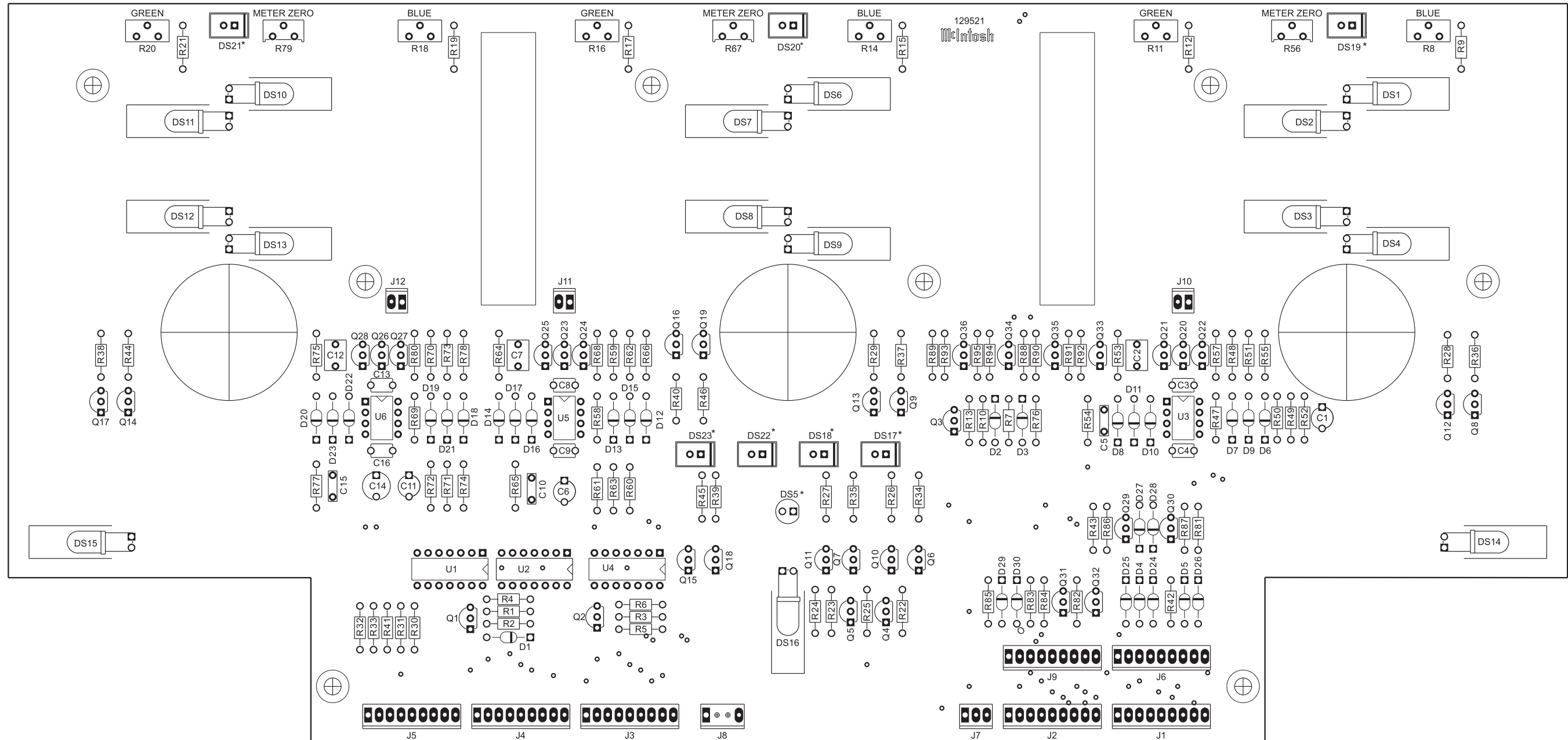

\* Denotes components on reverse or backside of PC Board.

6

CAPACITOR 050063

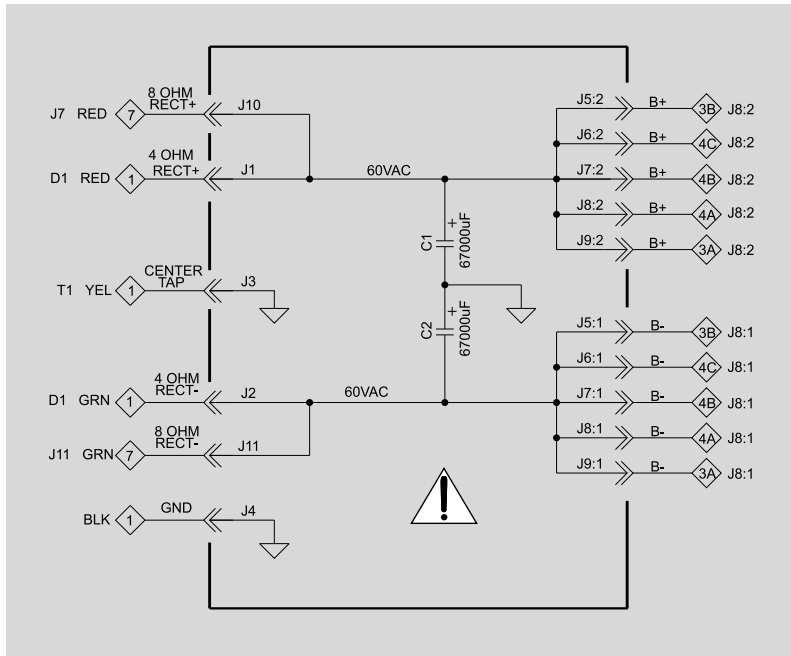

**!** WARNING Parts located in the shaded area have critical characteristics. Use only replacement parts recommended by the manufacturer.

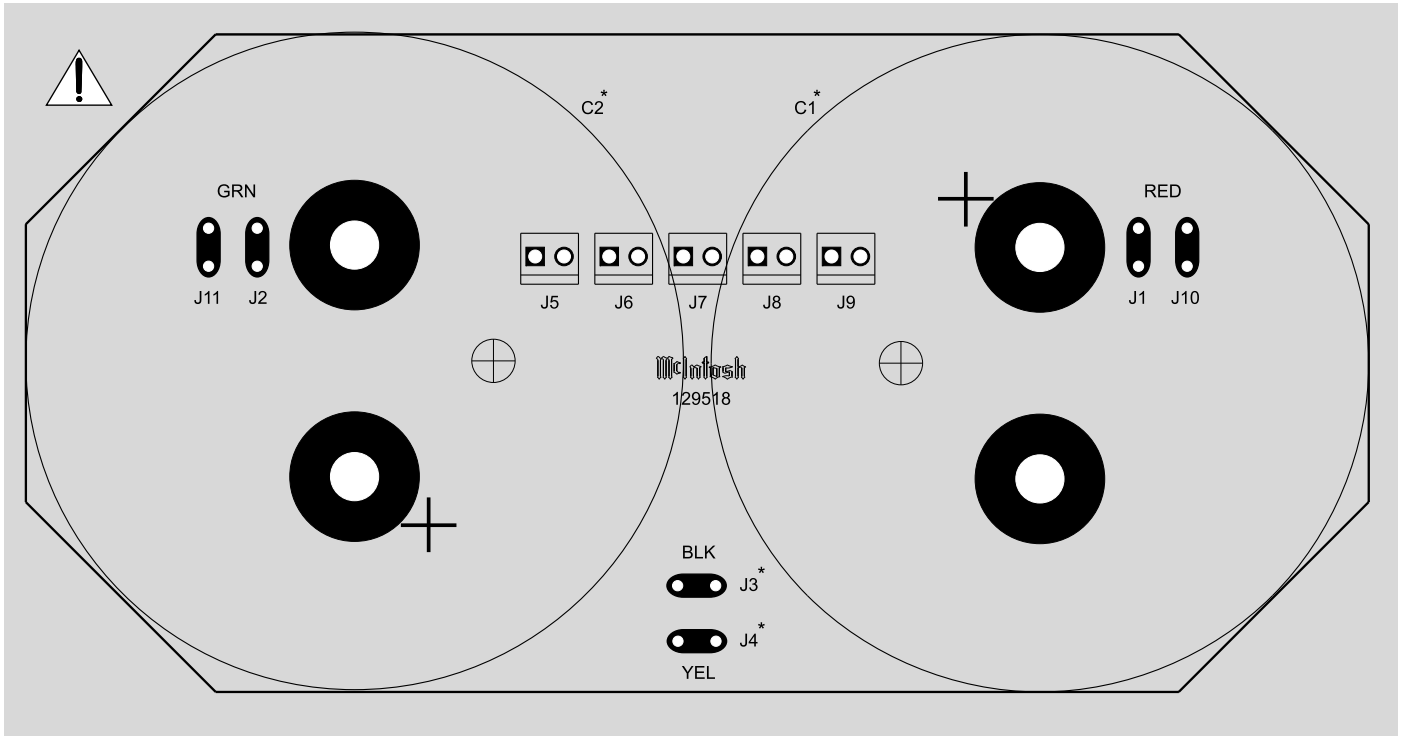

\* Denotes components on reverse or backside of PC Board.



**7** POWER SUPPLY 050062

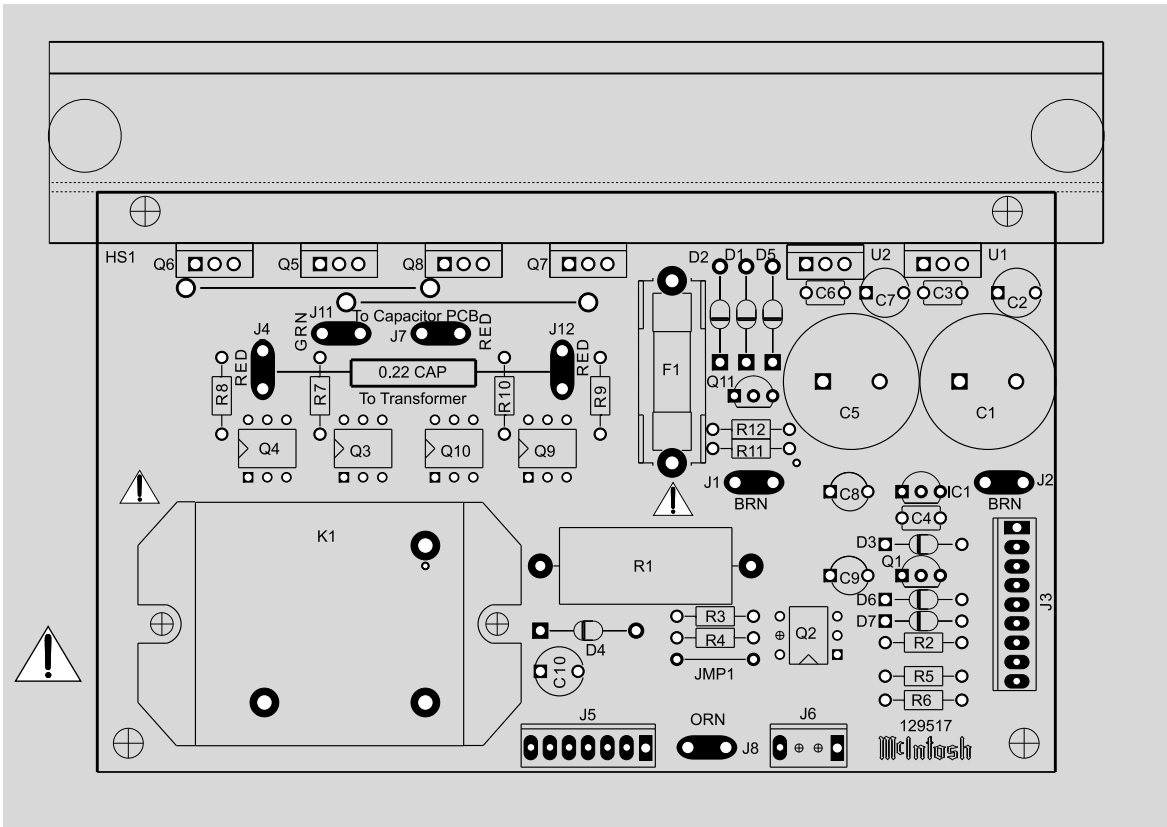

**!** WARNING Parts located in the shaded area have critical characteristics. Use only replacement parts recommended by the manufacturer.

# PARTS LIST

**Ref Part**  
**No. No. Description**

## 1 INTERCONNECT

C1	ASSEMBLY CAPACITOR	052005	C43	CAP ELECT 10UF 16V 4X5 CASE	066382
C2	ASSEMBLY CAPACITOR	052005	C44	CAP MONO 47PF 200V 10% NPO	061299
D1	DIODE BRID RECT	070139	C45	CAP ELECT 10UF 16V 4X5 CASE	066382
M1	METER MC207	124089	C46	CAP MONO 22PF 200V 10% NPO	061298
M2	METER MC207	124089	C47	CAP MONO 22PF 200V 10% NPO	061298
M3	METER MC207	124089	J1	CONN MALE 9 POS FRICTION LOCK	117244
RT1	ASSEMBLY THERMISTOR	052017	J2	JACK RCA BLK	117847
RT2	ASSEMBLY THERMISTOR	052017	J3	JACK RCA 1X2 BLK/BLK 14MM	117848
S1	SWITCH POWER	146243	J4	CONN 4 PIN	117215
S2	SWITCH POWER	146243	J5	CONN 4 PIN	117215
T1	POTTED TRANSFORMER POWER	050061	J6	RECEPTACLE XLR FEMALE	117685
TB1	TERMINAL BLOCK AC	074091	J7	RECEPTACLE XLR FEMALE	117685
TB2	POST BINDING DUAL	084124	J8	JACK RCA 1X2 BLK/BLK 14MM	117848
TB3	POST BINDING DUAL	084124	J9	CONN 4 PIN	117215
TB4	POST BINDING DUAL	084124	J10	CONN D 25-PIN	117501
TB5	POST BINDING DUAL	084124	J11	CONN 4 PIN	117215
TB6	POST BINDING DUAL	084124	J12	RECEPTACLE XLR FEMALE	117685
TB7	POST BINDING DUAL	084124	J13	RECEPTACLE XLR FEMALE	117685
TB8	POST BINDING DUAL	084124	J14	RECEPTACLE XLR FEMALE	117685

## 2 050065 INPUT PCB

C1	CAP ELECT 10UF 16V 4X5 CASE	066382	J16	JACK RCA 1X2 BLK/BLK 14MM	117848
C2	CAP ELECT 10UF 16V 4X5 CASE	066382	J17	CONN 4 PIN	117215
C3	CAP MONO 47PF 200V 10% NPO	061299	J18	RECEPTACLE XLR FEMALE	117685
C4	CAP MONO 47PF 200V 10% NPO	061299	J19	JACK HEADPHONE DUAL BLACK 1/8	117825
C5	CAP ELECT 10UF 16V 4X5 CASE	066382	J20	RECEPTACLE XLR FEMALE	117685
C6	CAP ELECT 10UF 16V 4X5 CASE	066382	R1	RES MF 1K 1% 1/4W	144090
C7	CAP MONO .1uF 50V 20% Z5U	061305	R2	RES MF 1K 1% 1/4W	144090
C8	CAP MONO .1uF 50V 20% Z5U	061305	R3	RES MF 20K 1% 1/4W	144104
C9	CAP MONO 22PF 200V 10% NPO	061298	R4	RES MF 221 OHM 1% 1/4W	144172
C10	CAP MONO 22PF 200V 10% NPO	061298	R5	RES MF 20K 1% 1/4W	144104
C11	CAP MONO 47PF 200V 10% NPO	061299	R6	RES MF 221 OHM 1% 1/4W	144172
C12	CAP ELECT 10UF 50V	066445	R7	RES MF 100K 1% 1/4W	144113
C13	CAP MONO 47PF 200V 10% NPO	061299	R8	RES MF 100K 1% 1/4W	144113
C14	CAP ELECT 10UF 50V	066445	R9	RES MF 20K 1% 1/4W	144104
C15	CAP ELECT 10UF 16V 4X5 CASE	066382	R10	RES MF 20K 1% 1/4W	144104
C16	CAP ELECT 10UF 16V 4X5 CASE	066382	R11	RES MF 10K 1% 1/4W	144053
C17	CAP MONO 47PF 200V 10% NPO	061299	R12	RES MF 10K 1% 1/4W	144053
C18	CAP ELECT 10UF 16V 4X5 CASE	066382	R13	RES MF 10 OHM 1% 1/4W	144157
C19	CAP MONO 47PF 200V 10% NPO	061299	R14	RES MF 10K 1% 1/4W	144053
C20	CAP MONO .1uF 50V 20% Z5U	061305	R16	RES MF 100K 1% 1/4W	144113
C21	CAP MONO .1uF 50V 20% Z5U	061305	R17	RES MF 10K 1% 1/4W	144053
C22	CAP ELECT 10UF 16V 4X5 CASE	066382	R18	RES MF 100K 1% 1/4W	144113
C23	CAP MONO 22PF 200V 10% NPO	061298	R19	RES MF 10 OHM 1% 1/4W	144157
C24	CAP MONO .1uF 50V 20% Z5U	061305	R20	RES MF 1K 1% 1/4W	144090
C25	CAP MONO .1uF 50V 20% Z5U	061305	R21	RES MF 20K 1% 1/4W	144104
C26	CAP MONO 47PF 200V 10% NPO	061299	R22	RES MF 221 OHM 1% 1/4W	144172
C27	CAP MONO 22PF 200V 10% NPO	061298	R23	RES MF 1K 1% 1/4W	144090
C28	CAP MONO 47PF 200V 10% NPO	061299	R24	RES MF 100K 1% 1/4W	144113
C29	CAP ELECT 10UF 16V 4X5 CASE	066382	R25	RES MF 20K 1% 1/4W	144104
C30	CAP MONO 47PF 200V 10% NPO	061299	R26	RES MF 20K 1% 1/4W	144104
C31	CAP ELECT 10UF 16V 4X5 CASE	066382	R27	RES MF 221 OHM 1% 1/4W	144172
C32	CAP MONO 22PF 200V 10% NPO	061298	R28	RES MF 100K 1% 1/4W	144113
C33	CAP MONO 47PF 200V 10% NPO	061299	R29	RES MF 10K 1% 1/4W	144053
C34	CAP ELECT 10UF 16V 4X5 CASE	066382	R30	RES MF 20K 1% 1/4W	144104
C35	CAP MONO 47PF 200V 10% NPO	061299	R31	RES MF 10K 1% 1/4W	144053
C36	CAP ELECT 10UF 16V 4X5 CASE	066382	R33	RES MF 100K 1% 1/4W	144113
C38	CAP MONO 22PF 200V 10% NPO	061298	R34	RES MF 10K 1% 1/4W	144053
C39	CAP MONO .1uF 50V 20% Z5U	061305	R35	RES MF 10K 1% 1/4W	144053
C40	CAP MONO .1uF 50V 20% Z5U	061305	R37	RES MF 100K 1% 1/4W	144113
C41	CAP MONO 47PF 200V 10% NPO	061299	R38	RES MF 1K 1% 1/4W	144090
			R39	RES MF 20K 1% 1/4W	144104
			R40	RES MF 221 OHM 1% 1/4W	144172
			R41	RES MF 100K 1% 1/4W	144113

## PARTS LIST con't

R42	RES MF 20K 1% 1/4W	144104	J2	CONN 4 PIN	117215
R43	RES MF 10K 1% 1/4W	144053	J4	CONN HEADER 2 PIN 0.156	117404
R44	RES MF 10K 1% 1/4W	144053	J5	BLADE FASTON .110	117712
R45	RES MF 100K 1% 1/4W	144113	J6	BLADE FASTON W/FEET	117708
R46	RES MF 100 OHM 1% 1/4W	144196	J8	CONN HEADER 2 PIN 0.156	117404
R47	RES MF 1K 1% 1/4W	144090	J9	CONN 2 PIN MALE	117213
R48	RES MF 20K 1% 1/4W	144104	K1	RELAY 24VDC 5A 277VAC	087057
R49	RES MF 221 OHM 1% 1/4W	144172	K2	RELAY 24VDC 5A 277VAC	087057
R50	RES MF 100K 1% 1/4W	144113	L2	CHOKE 0.65UH OUTPUT	122297
R51	RES MF 20K 1% 1/4W	144104	LD1	LDR NETWORK	144179
R55	RES MF 10K 1% 1/4W	144053	Q1	TRANSISTOR NPN	132223
R56	RES MF 10K 1% 1/4W	144053	Q2	TRANSISTOR PNP	132224
R58	RES MF 100K 1% 1/4W	144113	Q3	TRANSISTOR NPN	132268
R59	RES MF 1K 1% 1/4W	144090	Q4	TRANSISTOR PNP	132267
R60	RES MF 20K 1% 1/4W	144104	Q5	TRANSISTOR NPN	132223
R61	RES MF 221 OHM 1% 1/4W	144172	Q6	TRANSISTOR NPN	132285
R62	RES MF 100K 1% 1/4W	144113	Q7	TRANSISTOR PNP	132286
R63	RES MF 20K 1% 1/4W	144104	Q8	TRANSISTOR PNP POWER	132297
R64	RES MF 100 OHM 1% 1/4W	144196	Q9	TRANSISTOR NPN POWER	132296
R65	RES MF 10K 1% 1/4W	144053	Q10	TRANSISTOR PNP POWER	132297
R66	RES MF 10K 1% 1/4W	144053	Q11	TRANSISTOR NPN POWER	132296
R68	RES MF 100K 1% 1/4W	144113	Q20	TRANSISTOR NPN POWER	132296
S1	SWITCH SLIDE	148059	Q22	TRANSISTOR PNP POWER	132297
SP1	BRACKET PCB CARD MOUNTING	003611	Q23	TRANSISTOR NPN POWER	132296
U1	IC DUAL OPERATIONAL AMPLIFIER	133260	Q25	TRANSISTOR PNP POWER	132297
U2	IC DUAL OPERATIONAL AMPLIFIER	133260	Q27	TRANSISTOR PNP	132224
U3	IC DUAL OPERATIONAL AMPLIFIER	133260	Q29	TRANSISTOR NPN POWER	132255
U4	IC DUAL OPERATIONAL AMPLIFIER	133260	Q30	TRANSISTOR SI NPN 25V	132254
			Q31	TRANSISTOR NPN	132223
			Q32	TRANSISTOR NPN	132223
			Q33	TRANSISTOR PNP POWER	132255
			Q35	TRANSISTOR NPN	132223
			Q37	TRANSISTOR NPN	132285
			Q39	TRANSISTOR PNP	132286
			Q41	TRANSISTOR PNP	132224
			Q49	TRANSISTOR PNP	132224
			Q50	TRANSISTOR NPN	132223
			Q51	TRANSISTOR NPN	132223
			Q52	TRANSISTOR NPN	132223
			Q53	TRANSISTOR PNP POWER	132255
			Q54	TRANSISTOR PNP	132224
			Q55	TRANSISTOR PNP POWER	132255
			Q56	TRANSISTOR PNP POWER	132255
			Q59	TRANSISTOR NPN	132223
			Q60	TRANSISTOR SI NPN 25V	132254
			Q61	TRANSISTOR SI NPN 25V	132254
			Q63	TRANSISTOR NPN	132223
			Q64	TRANSISTOR PNP POWER	132255
			R1	RES MF 332 OHM 1% 1/4W	144446
			R2	RES MET OX 680 OHM 5% .5W	137093
			R3	RES MF 22.1K 1% 1/4W	144187
			R4	RES MF 100K 1% 1/4W	144113
			R5	RES MF 22.1K 1% 1/4W	144187
			R6	RES MET OX 1.8k 5% .5W	137094
			R7	RES MET OX 430 OHM 5% .5W	137095
			R8	RES MF 332 OHM 1% 1/4W	144446
			R9	RES MET OX 680 OHM 5% .5W	137093
			R10	RES MF 22.1K 1% 1/4W	144187
			R11	RES MET OX 1.8k 5% .5W	137094
			R12	RES MET OX 47 OHM 5% .5W	137096
			R13	POT TRIM 200 OHM 20% HORIZ AD	134390
			R14	RES MF 100K 1% 1/4W	144113
			R15	RES MF 100 OHM 1% 1/4W	144196

**050070 HEATSINK 1-CHANNEL PCB**

C1	CAP ELECT 47UF 35V	066446
C2	CAP ELECT 47UF 35V	066446
C3	CAP MONO .1uF 50V 20% Z5U	061305
C4	CAP POLYPROP 0.15UF 10% 250VDC	064363
C7	CAP MONO 100PF 100V 10% NPO	061300
C8	CAP MONO 100PF 100V 10% NPO	061300
C9	CAP MONO .01UF 50V 20% X7R	061304
C14	CAP MONO 100PF 100V 10% NPO	061300
C16	CAP MONO .01UF 50V 20% X7R	061304
C22	CAP ELECT 220UF 25V	066507
C27	CAP MONO 100PF 100V 10% NPO	061300
C30	CAP ELECT 47UF 35V	066446
C31	CAP ELECT .47UF 50V	066244
C32	CAP MONO .1uF 50V 20% Z5U	061305
C33	CAP MONO .1uF 50V 20% Z5U	061305
C35	CAP ELECT 10UF 100VDC	066462
C36	CAP ELECT 10UF 100VDC	066462
C37	CAP ELECT 10UF 100VDC	066462
C38	CAP ELECT 10UF 100VDC	066462
C40	CAP ELECT 220UF 50V 20%	066254
C41	CAP ELECT 10UF 100VDC	066462
C47	CAP POLYPROP .047UF 10% 250VDC	064364
C51	CAP ELECT 10UF 100VDC	066462
C200	CAP ELECT 10UF 100VDC	066462
D1	DIODE SILICON	070047
D2	DIODE SILICON	070047
D4	DIODE SILICON	070047
D5	DIODE SILICON	070047
D6	DIODE RECTIFIER	070131
D7	DIODE RECTIFIER	070131
IC2	IC DUAL AMP	133259
J1	CONN MALE 9 POS FRICTION LOCK	117244

# PARTS LIST con't

R16	RES MF 100 OHM 1% 1/4W	144196	C3	CAP MONO .1uF 50V 20% Z5U	061305
R17	RES MF 100 OHM 1% 1/4W	144196	C4	CAP POLYPROP 0.15UF 10% 250VDC	064363
R30	RES MF 475K 1% 1/4W	144364	C7	CAP MONO 100PF 100V 10% NPO	061300
R32	RES MF 47.5K 1% 1/4W	144108	C8	CAP MONO 100PF 100V 10% NPO	061300
R33	RES MF 47.5K 1% 1/4W	144108	C9	CAP MONO .01UF 50V 20% X7R	061304
R34	RES MF 5.11K 1% 1/4W	144083	C10	CAP ELECT 47UF 35V	066446
R36	RES 511 OHM 1% 1/4W	144123	C11	CAP ELECT 47UF 35V	066446
R37	RES MF 681K 1% 1/4W	144443	C12	CAP MONO 100PF 100V 10% NPO	061300
R38	RES MF 866 OHM 1% 1/4W	144028	C13	CAP MONO 100PF 100V 10% NPO	061300
R39	RES MF 2.21 OHM 1/4W 1%	144378	C14	CAP MONO 100PF 100V 10% NPO	061300
R41	RES WW DUAL .47 OHM 5% 3W	139244	C15	CAP MONO .1uF 50V 20% Z5U	061305
R42	RES WW DUAL .47 OHM 5% 3W	139244	C16	CAP MONO .01UF 50V 20% X7R	061304
R43	RES WW DUAL .47 OHM 5% 3W	139244	C17	CAP MONO .01UF 50V 20% X7R	061304
R45	RES WW DUAL .47 OHM 5% 3W	139244	C18	CAP MONO .01UF 50V 20% X7R	061304
R46	RES MF 4.75K 1% 1/4W	144097	C19	CAP MONO 100PF 100V 10% NPO	061300
R48	RES MF 100 OHM 1% 1/4W	144196	C22	CAP ELECT 220UF 25V	066507
R50	RES MF 14.7K 1% 1/4W	144149	C27	CAP MONO 100PF 100V 10% NPO	061300
R51	RES MF 221 OHM 1% 1/4W	144172	C28	CAP MONO 100PF 100V 10% NPO	061300
R52	RES MF 267K 1% 1/4W	144118	C29	CAP ELECT 47UF 35V	066446
R53	RES MF 221 OHM 1% 1/4W	144172	C30	CAP ELECT 47UF 35V	066446
R54	RES MF 3.32K 1% 1/4W	144095	C31	CAP ELECT .47UF 50V	066244
R55	RES MF 3.32K 1% 1/4W	144095	C32	CAP MONO .1uF 50V 20% Z5U	061305
R56	RES MF 10K 1% 1/4W	144053	C33	CAP MONO .1uF 50V 20% Z5U	061305
R57	RES MF 475K 1% 1/4W	144364	C35	CAP ELECT 10UF 100VDC	066462
R58	RES MF 1.1K 1% 1/4W	144091	C36	CAP ELECT 10UF 100VDC	066462
R59	RES MF 2.21 OHM 1/4W 1%	144378	C37	CAP ELECT 10UF 100VDC	066462
R60	RES FP 22 OHM 1/4W 5%	137033	C38	CAP ELECT 10UF 100VDC	066462
R62	RES MF 22.1K 1% 1/4W	144187	C39	CAP ELECT .47UF 50V	066244
R63	RES FP 22 OHM 1/4W 5%	137033	C40	CAP ELECT 220UF 50V 20%	066254
R65	RES MF 681K 1% 1/4W	144443	C41	CAP ELECT 10UF 100VDC	066462
R67	RES MF 100 OHM 1% 1/4W	144196	C44	CAP ELECT 220UF 25V	066507
R70	RES MF 100 OHM 1% 1/4W	144196	C47	CAP POLYPROP .047UF 10% 250VDC	064364
R71	RES MF 100 OHM 1% 1/4W	144196	C48	CAP POLYPROP .047UF 10% 250VDC	064364
R72	RES MF 100 OHM 1% 1/4W	144196	C50	CAP ELECT 10UF 100VDC	066462
R77	RES MF 1M 1/4W	144269	C51	CAP ELECT 10UF 100VDC	066462
R79	RES CF 10 OHM 5% 1/2W	141165	C200	CAP ELECT 10UF 100VDC	066462
R82	RES MF 1M 1/4W	144269	D1	DIODE SILICON	070047
R83	RES MF 10K 1% 1/4W	144053	D2	DIODE SILICON	070047
R84	RES MF 47.5K 1% 1/4W	144108	D4	DIODE SILICON	070047
R85	RES MF 1.1K 1% 1/4W	144091	D5	DIODE SILICON	070047
R86	RES MF 4.75K 1% 1/4W	144097	D6	DIODE RECTIFIER	070131
R88	RES MF 12.1K 1% 1/4W	144154	D7	DIODE RECTIFIER	070131
R90	RES MF 1.1K 1% 1/4W	144091	D8	DIODE SILICON	070047
R93	RES MF 4.75K 1% 1/4W	144097	D9	DIODE SILICON	070047
R101	RES MF 953 OHM 1/4W 1%	144473	D11	DIODE SILICON	070047
R103	RES MF 332K 1% 1/4W	144119	D12	DIODE SILICON	070047
R104	RES MF 15K 1% 1/4W	144412	D13	DIODE RECTIFIER	070131
R105	RES MF 6.49K 1% 1/4W	144140	D14	DIODE RECTIFIER	070131
R106	RES MF 475 OHM 1% 1/4W	144086	IC1	IC DUAL AMP	133259
R109	RES CF 0 OHM 5% 1/4W	141389	IC2	IC DUAL AMP	133259
R111	RES MET OX 430 OHM 5% .5W	137095	J1	CONN MALE 9 POS FRICTION LOCK	117244
R114	RES CF 10 OHM 5% 1/2W	141165	J2	CONN 4 PIN	117215
R119	RES MO 4.7 OHM 1W 5%	144464	J3	CONN HEADER 2 PIN 0.156	117404
R122	RES MF 47.5K 1% 1/4W	144108	J4	CONN HEADER 2 PIN 0.156	117404
R123	RES MF 22.1K 1% 1/4W	144187	J5	BLADE FASTON .110	117712
R124	RES MF 47.5K 1% 1/4W	144108	J6	BLADE FASTON W/FEET	117708
RT1	SENSOR THERMAL	144249	J8	CONN HEADER 2 PIN 0.156	117404
RT2	SENSOR THERMAL	144249	J9	CONN 2 PIN MALE	117213
			J10	CONN 2 PIN MALE	117213
			K1	RELAY 24VDC 5A 277VAC	087057
			K2	RELAY 24VDC 5A 277VAC	087057
			L1	CHOKE 0.65UH OUTPUT	122297
			L2	CHOKE 0.65UH OUTPUT	122297

4A

4B

**050064 HEATSINK 2-CHANNEL PCB**

4B

C1	CAP ELECT 47UF 35V	066446
C2	CAP ELECT 47UF 35V	066446



## PARTS LIST con't

LD1	LDR NETWORK	144179	Q62	TRANSISTOR PNP	132224
LD2	LDR NETWORK	144179	Q63	TRANSISTOR NPN	132223
Q1	TRANSISTOR NPN	132223	Q64	TRANSISTOR PNP POWER	132255
Q2	TRANSISTOR PNP	132224	R1	RES MF 332 OHM 1% 1/4W	144446
Q3	TRANSISTOR NPN	132268	R2	RES MET OX 680 OHM 5% .5W	137093
Q4	TRANSISTOR PNP	132267	R3	RES MF 22.1K 1% 1/4W	144187
Q5	TRANSISTOR NPN	132223	R4	RES MF 100K 1% 1/4W	144113
Q6	TRANSISTOR NPN	132285	R5	RES MF 22.1K 1% 1/4W	144187
Q7	TRANSISTOR PNP	132286	R6	RES MET OX 1.8k 5% .5W	137094
Q8	TRANSISTOR PNP POWER	132297	R7	RES MET OX 430 OHM 5% .5W	137095
Q9	TRANSISTOR NPN POWER	132296	R8	RES MF 332 OHM 1% 1/4W	144446
Q10	TRANSISTOR PNP POWER	132297	R9	RES MET OX 680 OHM 5% .5W	137093
Q11	TRANSISTOR NPN POWER	132296	R10	RES MF 22.1K 1% 1/4W	144187
Q12	TRANSISTOR NPN	132223	R11	RES MET OX 1.8k 5% .5W	137094
Q13	TRANSISTOR PNP	132224	R12	RES MET OX 47 OHM 5% .5W	137096
Q14	TRANSISTOR NPN	132223	R13	POT TRIM 200 OHM 20% HORIZ AD	134390
Q15	TRANSISTOR PNP	132286	R14	RES MF 100K 1% 1/4W	144113
Q16	TRANSISTOR NPN	132285	R15	RES MF 100 OHM 1% 1/4W	144196
Q17	TRANSISTOR PNP	132267	R16	RES MF 100 OHM 1% 1/4W	144196
Q18	TRANSISTOR NPN	132268	R17	RES MF 100 OHM 1% 1/4W	144196
Q19	TRANSISTOR NPN POWER	132296	R18	RES MET OX 47 OHM 5% .5W	137096
Q20	TRANSISTOR NPN POWER	132296	R19	RES MET OX 1.8k 5% .5W	137094
Q21	TRANSISTOR PNP POWER	132297	R20	RES MF 332 OHM 1% 1/4W	144446
Q22	TRANSISTOR PNP POWER	132297	R21	RES MF 22.1K 1% 1/4W	144187
Q23	TRANSISTOR NPN POWER	132296	R22	RES MET OX 680 OHM 5% .5W	137093
Q24	TRANSISTOR NPN POWER	132296	R23	RES MET OX 430 OHM 5% .5W	137095
Q25	TRANSISTOR PNP POWER	132297	R24	RES MET OX 680 OHM 5% .5W	137093
Q26	TRANSISTOR PNP POWER	132297	R25	RES MF 22.1K 1% 1/4W	144187
Q27	TRANSISTOR PNP	132224	R26	RES MET OX 1.8k 5% .5W	137094
Q28	TRANSISTOR SI NPN 25V	132254	R27	RES MF 332 OHM 1% 1/4W	144446
Q29	TRANSISTOR PNP POWER	132255	R28	POT TRIM 200 OHM 20% HORIZ AD	134390
Q30	TRANSISTOR SI NPN 25V	132254	R29	RES MF 475K 1% 1/4W	144364
Q31	TRANSISTOR NPN	132223	R30	RES MF 475K 1% 1/4W	144364
Q32	TRANSISTOR NPN	132223	R31	RES MF 5.11K 1% 1/4W	144083
Q33	TRANSISTOR PNP POWER	132255	R32	RES MF 47.5K 1% 1/4W	144108
Q34	TRANSISTOR NPN	132223	R33	RES MF 47.5K 1% 1/4W	144108
Q35	TRANSISTOR NPN	132223	R34	RES MF 5.11K 1% 1/4W	144083
Q36	TRANSISTOR NPN	132285	R35	RES MF 47.5K 1% 1/4W	144108
Q37	TRANSISTOR NPN	132285	R36	RES 511 OHM 1% 1/4W	144123
Q38	TRANSISTOR PNP POWER	132255	R37	RES MF 681K 1% 1/4W	144443
Q39	TRANSISTOR PNP	132286	R38	RES MF 866 OHM 1% 1/4W	144028
Q40	TRANSISTOR PNP	132224	R39	RES MF 2.21 OHM 1/4W 1%	144378
Q41	TRANSISTOR PNP	132224	R40	RES WW DUAL .47 OHM 5% 3W	139244
Q42	TRANSISTOR NPN	132223	R41	RES WW DUAL .47 OHM 5% 3W	139244
Q43	TRANSISTOR PNP	132224	R42	RES WW DUAL .47 OHM 5% 3W	139244
Q44	TRANSISTOR NPN POWER	132255	R43	RES WW DUAL .47 OHM 5% 3W	139244
Q45	TRANSISTOR PNP POWER	132255	R44	RES WW DUAL .47 OHM 5% 3W	139244
Q46	TRANSISTOR PNP	132224	R45	RES WW DUAL .47 OHM 5% 3W	139244
Q47	TRANSISTOR SI NPN 25V	132254	R46	RES MF 4.75K 1% 1/4W	144097
Q48	TRANSISTOR PNP	132286	R47	RES MF 4.75K 1% 1/4W	144097
Q49	TRANSISTOR PNP	132224	R48	RES MF 100 OHM 1% 1/4W	144196
Q50	TRANSISTOR NPN	132223	R49	RES MF 1.1K 1% 1/4W	144091
Q51	TRANSISTOR NPN	132223	R50	RES MF 14.7K 1% 1/4W	144149
Q52	TRANSISTOR NPN	132223	R51	RES MF 221 OHM 1% 1/4W	144172
Q53	TRANSISTOR PNP POWER	132255	R52	RES MF 267K 1% 1/4W	144118
Q54	TRANSISTOR PNP	132224	R53	RES MF 221 OHM 1% 1/4W	144172
Q55	TRANSISTOR PNP POWER	132255	R54	RES MF 3.32K 1% 1/4W	144095
Q56	TRANSISTOR PNP POWER	132255	R55	RES MF 3.32K 1% 1/4W	144095
Q57	TRANSISTOR SI NPN 25V	132254	R56	RES MF 10K 1% 1/4W	144053
Q58	TRANSISTOR NPN	132223	R57	RES MF 475K 1% 1/4W	144364
Q59	TRANSISTOR NPN	132223	R58	RES MF 1.1K 1% 1/4W	144091
Q60	TRANSISTOR SI NPN 25V	132254	R59	RES MF 2.21 OHM 1/4W 1%	144378
Q61	TRANSISTOR SI NPN 25V	132254	R60	RES FP 22 OHM 1/4W 5%	137033

# PARTS LIST con't

R61	RES MF 100 OHM 1% 1/4W	144196		
R62	RES MF 22.1K 1% 1/4W	144187		
R63	RES FP 22 OHM 1/4W 5%	137033		
R64	RES MF 10K 1% 1/4W	144053		
R65	RES MF 681K 1% 1/4W	144443		
R66	RES MF 681K 1% 1/4W	144443		
R67	RES MF 100 OHM 1% 1/4W	144196		
R68	RES MF 475K 1% 1/4W	144364		
R69	RES MF 22.1K 1% 1/4W	144187		
R70	RES MF 100 OHM 1% 1/4W	144196		
R71	RES MF 100 OHM 1% 1/4W	144196		
R72	RES MF 100 OHM 1% 1/4W	144196		
R73	RES MF 100 OHM 1% 1/4W	144196		
R74	RES MF 100 OHM 1% 1/4W	144196		
R75	RES MF 267K 1% 1/4W	144118		
R76	RES MF 221 OHM 1% 1/4W	144172		
R77	RES MF 1M 1/4W	144269		
R78	RES MF 100 OHM 1% 1/4W	144196		
R79	RES CF 10 OHM 5% 1/2W	141165		
R80	RES CF 10 OHM 5% 1/2W	141165		
R81	RES MF 100 OHM 1% 1/4W	144196		
R82	RES MF 1M 1/4W	144269		
R83	RES MF 10K 1% 1/4W	144053		
R84	RES MF 47.5K 1% 1/4W	144108		
R85	RES MF 1.1K 1% 1/4W	144091		
R86	RES MF 4.75K 1% 1/4W	144097		
R87	RES MF 14.7K 1% 1/4W	144149		
R88	RES MF 12.1K 1% 1/4W	144154		
R89	RES MF 953 OHM 1/4W 1%	144473		
R90	RES MF 1.1K 1% 1/4W	144091		
R91	RES MF 681K 1% 1/4W	144443		
R92	RES MF 866 OHM 1% 1/4W	144028		
R93	RES MF 4.75K 1% 1/4W	144097		
R94	RES MF 47.5K 1% 1/4W	144108		
R95	RES MF 1.1K 1% 1/4W	144091		
R96	RES MF 3.32K 1% 1/4W	144095		
R97	RES 511 OHM 1% 1/4W	144123		
R98	RES MF 3.32K 1% 1/4W	144095		
R99	RES MF 221 OHM 1% 1/4W	144172		
R100	RES MF 1.1K 1% 1/4W	144091		
R101	RES MF 953 OHM 1/4W 1%	144473		
R102	RES MF 332K 1% 1/4W	144119		
R103	RES MF 332K 1% 1/4W	144119		
R104	RES MF 15K 1% 1/4W	144412		
R105	RES MF 6.49K 1% 1/4W	144140		
R106	RES MF 475 OHM 1% 1/4W	144086		
R107	RES MF 475 OHM 1% 1/4W	144086		
R108	RES MF 6.49K 1% 1/4W	144140		
R109	RES CF 0 OHM 5% 1/4W	141389		
R110	RES MET OX 430 OHM 5% .5W	137095		
R111	RES MET OX 430 OHM 5% .5W	137095		
R112	RES MF 1M 1/4W	144269		
R113	RES CF 10 OHM 5% 1/2W	141165		
R114	RES CF 10 OHM 5% 1/2W	141165		
R115	RES MF 1M 1/4W	144269		
R119	RES MO 4.7 OHM 1W 5%	144464		
R120	RES MO 4.7 OHM 1W 5%	144464		
R122	RES MF 47.5K 1% 1/4W	144108		
R123	RES MF 22.1K 1% 1/4W	144187		
R124	RES MF 47.5K 1% 1/4W	144108		
RT1	SENSOR THERMAL	144249		
RT2	SENSOR THERMAL	144249		
			<b>5</b>	<b>050066 DISPLAY PCB</b>
			C1	CAP ELECT 10UF 50V 066445
			C2	CAP MPF 0.47UF 5% 50/63VDC 064333
			C3	CAP MONO .1uF 50V 20% Z5U 061305
			C4	CAP MONO .1uF 50V 20% Z5U 061305
			C5	CAP MPF 0.1UF 5% 63VDC 064325
			C6	CAP ELECT 10UF 50V 066445
			C7	CAP MPF 0.47UF 5% 50/63VDC 064333
			C8	CAP MONO .1uF 50V 20% Z5U 061305
			C9	CAP MONO .1uF 50V 20% Z5U 061305
			C10	CAP MPF 0.1UF 5% 63VDC 064325
			C11	CAP ELECT 10UF 50V 066445
			C12	CAP MPF 0.47UF 5% 50/63VDC 064333
			C13	CAP MONO .1uF 50V 20% Z5U 061305
			C14	CAP ELECT 100UF 16V OR 25V 066447
			C15	CAP MPF 0.1UF 5% 63VDC 064325
			C16	CAP MONO .1uF 50V 20% Z5U 061305
			D1	DIODE SILICON 070047
			D2	DIODE SILICON 070047
			D3	DIODE SILICON 070047
			D4	DIODE SILICON 070047
			D5	DIODE SILICON 070047
			D6	DIODE SILICON 070047
			D7	DIODE SILICON 070047
			D8	DIODE SILICON 070047
			D9	DIODE SILICON 070047
			D10	DIODE SILICON 070047
			D11	DIODE SILICON 070047
			D12	DIODE SILICON 070047
			D13	DIODE SILICON 070047
			D14	DIODE SILICON 070047
			D15	DIODE SILICON 070047
			D16	DIODE SILICON 070047
			D17	DIODE SILICON 070047
			D18	DIODE SILICON 070047
			D19	DIODE SILICON 070047
			D20	DIODE SILICON 070047
			D21	DIODE SILICON 070047
			D22	DIODE SILICON 070047
			D23	DIODE SILICON 070047
			D24	DIODE SILICON 070047
			D25	DIODE SILICON 070047
			D26	DIODE SILICON 070047
			D27	DIODE SILICON 070047
			D28	DIODE SILICON 070047
			D29	DIODE SILICON 070047
			D30	DIODE SILICON 070047
			DS1	LED BLUE 5MM HI-INTENSITY 058166
			DS2	LED BLUE 5MM HI-INTENSITY 058166
			DS3	LED GREEN 5MM HI-INTENSITY 058165
			DS4	LED GREEN 5MM HI-INTENSITY 058165
			DS5	LED RED HIGH EFFICIENCY 058148
			DS6	LED BLUE 5MM HI-INTENSITY 058166
			DS7	LED BLUE 5MM HI-INTENSITY 058166
			DS8	LED GREEN 5MM HI-INTENSITY 058165
			DS9	LED GREEN 5MM HI-INTENSITY 058165
			DS10	LED BLUE 5MM HI-INTENSITY 058166
			DS11	LED BLUE 5MM HI-INTENSITY 058166
			DS12	LED GREEN 5MM HI-INTENSITY 058165
			DS13	LED GREEN 5MM HI-INTENSITY 058165
			DS14	LED GREEN 5MM HI-INTENSITY 058165
			DS15	LED GREEN 5MM HI-INTENSITY 058165
			DS16	LED GREEN 5MM HI-INTENSITY 058165

## PARTS LIST con't

DS17	LED AMBER	058133	R9	RES MF 221 OHM 1% 1/4W	144172
DS18	LED AMBER	058133	R10	RES MF 1.5K 1% 1/4W	144128
DS19	LED AMBER	058133	R11	POT TRIM 500 OHM 20% HORIZ ADJ	134410
DS20	LED AMBER	058133	R12	RES MF 221 OHM 1% 1/4W	144172
DS21	LED AMBER	058133	R13	RES MF 5.62K OHM 1% 1/4W	144447
DS22	LED AMBER	058133	R14	POT TRIM 500 OHM 20% HORIZ ADJ	134410
DS23	LED AMBER	058133	R15	RES MF 221 OHM 1% 1/4W	144172
J1	CONN MALE 9 POS FRICTION LOCK	117244	R16	POT TRIM 500 OHM 20% HORIZ ADJ	134410
J2	CONN MALE 9 POS FRICTION LOCK	117244	R17	RES MF 221 OHM 1% 1/4W	144172
J3	CONN MALE 9 POS FRICTION LOCK	117244	R18	POT TRIM 500 OHM 20% HORIZ ADJ	134410
J4	CONN MALE 9 POS FRICTION LOCK	117244	R19	RES MF 221 OHM 1% 1/4W	144172
J5	CONN MALE 9 POS FRICTION LOCK	117244	R20	POT TRIM 500 OHM 20% HORIZ ADJ	134410
J6	CONN MALE 9 POS FRICTION LOCK	117244	R21	RES MF 221 OHM 1% 1/4W	144172
J7	CONN 3 POS MALE MTS100 NORM	117214	R22	RES MF 27.4K 1% 1/4W	144141
J8	CONN 4 PIN	117215	R23	RES MF 365 OHM 1% 1/4W	144071
J9	CONN MALE 9 POS FRICTION LOCK	117244	R24	RES MF 1K 1% 1/4W	144090
J10	CONN 2 PIN MALE	117213	R25	RES MF 5.62K OHM 1% 1/4W	144447
J11	CONN 2 PIN MALE	117213	R26	RES MF 681 OHM 1% 1/4W	144195
J12	CONN 2 PIN MALE	117213	R27	RES MF 681 OHM 1% 1/4W	144195
Q1	TRANSISTOR PNP	132224	R28	RES MF 681 OHM 1% 1/4W	144195
Q2	TRANSISTOR PNP	132224	R29	RES MF 681 OHM 1% 1/4W	144195
Q3	TRANSISTOR NPN	132223	R30	RES MF 1M 1/4W	144269
Q4	TRANSISTOR PNP	132224	R31	RES MF 1M 1/4W	144269
Q5	TRANSISTOR NPN	132223	R32	RES MF 1M 1/4W	144269
Q6	TRANSISTOR PNP	132224	R33	RES MF 1M 1/4W	144269
Q7	TRANSISTOR PNP	132224	R34	RES MF 187K 1% 1/4W	144406
Q8	TRANSISTOR PNP	132224	R35	RES MF 187K 1% 1/4W	144406
Q9	TRANSISTOR PNP	132224	R36	RES MF 187K 1% 1/4W	144406
Q10	TRANSISTOR PNP	132224	R37	RES MF 187K 1% 1/4W	144406
Q11	TRANSISTOR PNP	132224	R38	RES MF 681 OHM 1% 1/4W	144195
Q12	TRANSISTOR PNP	132224	R39	RES MF 681 OHM 1% 1/4W	144195
Q13	TRANSISTOR PNP	132224	R40	RES MF 681 OHM 1% 1/4W	144195
Q14	TRANSISTOR PNP	132224	R41	RES MF 1M 1/4W	144269
Q15	TRANSISTOR PNP	132224	R42	RES MF 10K 1% 1/4W	144053
Q16	TRANSISTOR PNP	132224	R43	RES MF 121K 1% 1/4W	144418
Q17	TRANSISTOR PNP	132224	R44	RES MF 187K 1% 1/4W	144406
Q18	TRANSISTOR PNP	132224	R45	RES MF 187K 1% 1/4W	144406
Q19	TRANSISTOR PNP	132224	R46	RES MF 187K 1% 1/4W	144406
Q20	TRANSISTOR NPN	132223	R47	RES MF 68.1K 1% 1/4W	144081
Q21	TRANSISTOR NPN	132223	R48	RES MF 10M 1% 1/4W	144264
Q22	TRANSISTOR NPN	132223	R49	RES MF 27.4K 1% 1/4W	144141
Q23	TRANSISTOR NPN	132223	R50	RES MF 2.67K 1% 1/4W	144121
Q24	TRANSISTOR NPN	132223	R51	RES MF 10.2K 1% 1/4W	144130
Q25	TRANSISTOR NPN	132223	R52	RES MF 5.62K OHM 1% 1/4W	144447
Q26	TRANSISTOR NPN	132223	R53	RES MF 221 OHM 1% 1/4W	144172
Q27	TRANSISTOR NPN	132223	R54	RES MF 4.75M 1/4W 1%	144379
Q28	TRANSISTOR NPN	132223	R55	RES MF 121K 1% 1/4W	144418
Q29	TRANSISTOR NPN	132223	R56	POT TRIM 100K OHM 20%	134383
Q30	TRANSISTOR NPN	132223	R57	RES MF 1.21K 1% 1/4W	144191
Q31	TRANSISTOR NPN	132223	R58	RES MF 68.1K 1% 1/4W	144081
Q32	TRANSISTOR NPN	132223	R59	RES MF 10M 1% 1/4W	144264
Q33	TRANSISTOR NPN	132223	R60	RES MF 27.4K 1% 1/4W	144141
Q34	TRANSISTOR NPN	132223	R61	RES MF 2.67K 1% 1/4W	144121
Q35	TRANSISTOR PNP	132224	R62	RES MF 10.2K 1% 1/4W	144130
Q36	TRANSISTOR PNP	132224	R63	RES MF 5.62K OHM 1% 1/4W	144447
R1	RES MF 5.62K OHM 1% 1/4W	144447	R64	RES MF 221 OHM 1% 1/4W	144172
R2	RES MF 15K 1% 1/4W	144412	R65	RES MF 4.75M 1/4W 1%	144379
R3	RES MF 100K 1% 1/4W	144113	R66	RES MF 121K 1% 1/4W	144418
R4	RES MF 22.1K 1% 1/4W	144187	R67	POT TRIM 100K OHM 20%	134383
R5	RES MF 10K 1% 1/4W	144053	R68	RES MF 1.21K 1% 1/4W	144191
R6	RES MF 100K 1% 1/4W	144113	R69	RES MF 68.1K 1% 1/4W	144081
R7	RES MF 5.62K OHM 1% 1/4W	144447	R70	RES MF 10M 1% 1/4W	144264
R8	POT TRIM 500 OHM 20% HORIZ ADJ	134410	R71	RES MF 27.4K 1% 1/4W	144141

# PARTS LIST con't

R72	RES MF 2.67K 1% 1/4W	144121	D5	DIODE RECTIFIER	070131
R73	RES MF 10.2K 1% 1/4W	144130	D6	DIODE ZENER 6.2V 5% 500MW	070085
R74	RES MF 5.62K OHM 1% 1/4W	144447	D7	DIODE SILICON	070047
R75	RES MF 221 OHM 1% 1/4W	144172	F1	FUSE 3.15A SLO-BLO 5X20 IEC	089098
R76	RES MF 20 OHM 1/4W	144174	IC1	IC REGULATOR +5 VOLT	133093
R77	RES MF 4.75M 1/4W 1%	144379	J1	BLADE FASTON W/FEET	117708
R78	RES MF 121K 1% 1/4W	144418	J2	BLADE FASTON W/FEET	117708
R79	POT TRIM 100K OHM 20%	134383	J3	CONN MALE 9 POS FRICTION LOCK	117244
R80	RES MF 1.21K 1% 1/4W	144191	J4	BLADE FASTON W/FEET	117708
R81	RES MF 121K 1% 1/4W	144418	J5	CONN MALE 7 PIN	117217
R82	RES MF 10K 1% 1/4W	144053	J6	CONN 4 PIN	117215
R83	RES MF 121K 1% 1/4W	144418	J7	BLADE FASTON W/FEET	117708
R84	RES MF 47.5K 1% 1/4W	144108	J8	BLADE FASTON W/FEET	117708
R85	RES MF 10K 1% 1/4W	144053	J11	BLADE FASTON W/FEET	117708
R86	RES MF 47.5K 1% 1/4W	144108	J12	BLADE FASTON W/FEET	117708
R87	RES MF 47.5K 1% 1/4W	144108	K1	RELAY 48VDC	087049
R88	RES MF 187K 1% 1/4W	144406	Q1	TRANSISTOR NPN	132223
R89	RES MF 187K 1% 1/4W	144406	Q2	TRIAC OPTOCOUPLER	131024
R90	RES MF 15K 1% 1/4W	144412	Q3	OPTOCOUPLER OPTICAL SCR	131025
R91	RES MF 15K 1% 1/4W	144412	Q4	OPTOCOUPLER OPTICAL SCR	131025
R92	RES MF 15K 1% 1/4W	144412	Q5	SCR REV BLOCKING THYRISTOR	131026
R93	RES MF 15K 1% 1/4W	144412	Q6	SCR REV BLOCKING THYRISTOR	131026
R94	RES MF 15K 1% 1/4W	144412	Q7	SCR REV BLOCKING THYRISTOR	131026
R95	RES MF 15K 1% 1/4W	144412	Q8	SCR REV BLOCKING THYRISTOR	131026
U1	IC HEX SCHMITT INVERTER	133526	Q9	OPTOCOUPLER OPTICAL SCR	131025
U2	IC AND 3 INPUT X 3	133185	Q10	OPTOCOUPLER OPTICAL SCR	131025
U3	IC DUAL OPERATIONAL AMPLIFIER	133260	Q11	TRANSISTOR NPN	132223
U4	IC QUAD ANALOG SW	133117	R1	RES WW 1K 5W 10%	139121
U5	IC DUAL OPERATIONAL AMPLIFIER	133260	R2	RES MF 332K 1% 1/4W	144119
U6	IC DUAL OPERATIONAL AMPLIFIER	133260	R3	RES MF 33.2K 1% 1/4W	144015

## 6 050063 CAPACITOR PCB

C1	CAP ELECT 67000UF 100V	066543	R7	RES MET OX 47 OHM 5% .5W	137096
C2	CAP ELECT 67000UF 100V	066543	R8	RES MET OX 47 OHM 5% .5W	137096
J1	BLADE FASTON W/FEET	117708	R9	RES MET OX 47 OHM 5% .5W	137096
J2	BLADE FASTON W/FEET	117708	R10	RES MET OX 47 OHM 5% .5W	137096
J3	BLADE FASTON W/FEET	117708	R11	RES MF 475 OHM 1% 1/4W	144086
J4	BLADE FASTON W/FEET	117708	R12	RES MF 20K 1% 1/4W	144104
J5	CONN HEADER 2 PIN 0.156	117404	U1	IC REGULATOR +12 VOLT	133119
J6	CONN HEADER 2 PIN 0.156	117404	U2	IC REGULATOR -12V 1A	133138
J7	CONN HEADER 2 PIN 0.156	117404			
J8	CONN HEADER 2 PIN 0.156	117404			
J9	CONN HEADER 2 PIN 0.156	117404			
J10	BLADE FASTON W/FEET	117708			
J11	BLADE FASTON W/FEET	117708			

## 7 050062 POWER SUPPLY PCB

C1	CAP ELECT 330UF 35V	066509
C2	CAP ELECT 100UF 25V	066447
C3	CAP MONO .1uF 50V 20% Z5U	061305
C4	CAP MONO .1uF 50V 20% Z5U	061305
C5	CAP ELECT 330UF 35V	066509
C6	CAP MONO .1uF 50V 20% Z5U	061305
C7	CAP ELECT 100UF 25V	066447
C8	CAP ELECT 10UF 50V	066445
C9	CAP ELECT 10UF 50V	066445
C10	CAP ELECT 22UF 100V	066506
D1	DIODE RECTIFIER	070131
D2	DIODE RECTIFIER	070131
D3	DIODE ZENER 6.2V 5% 500MW	070085
D4	DIODE RECTIFIER	070131

# MC207 EXPLODED VIEW

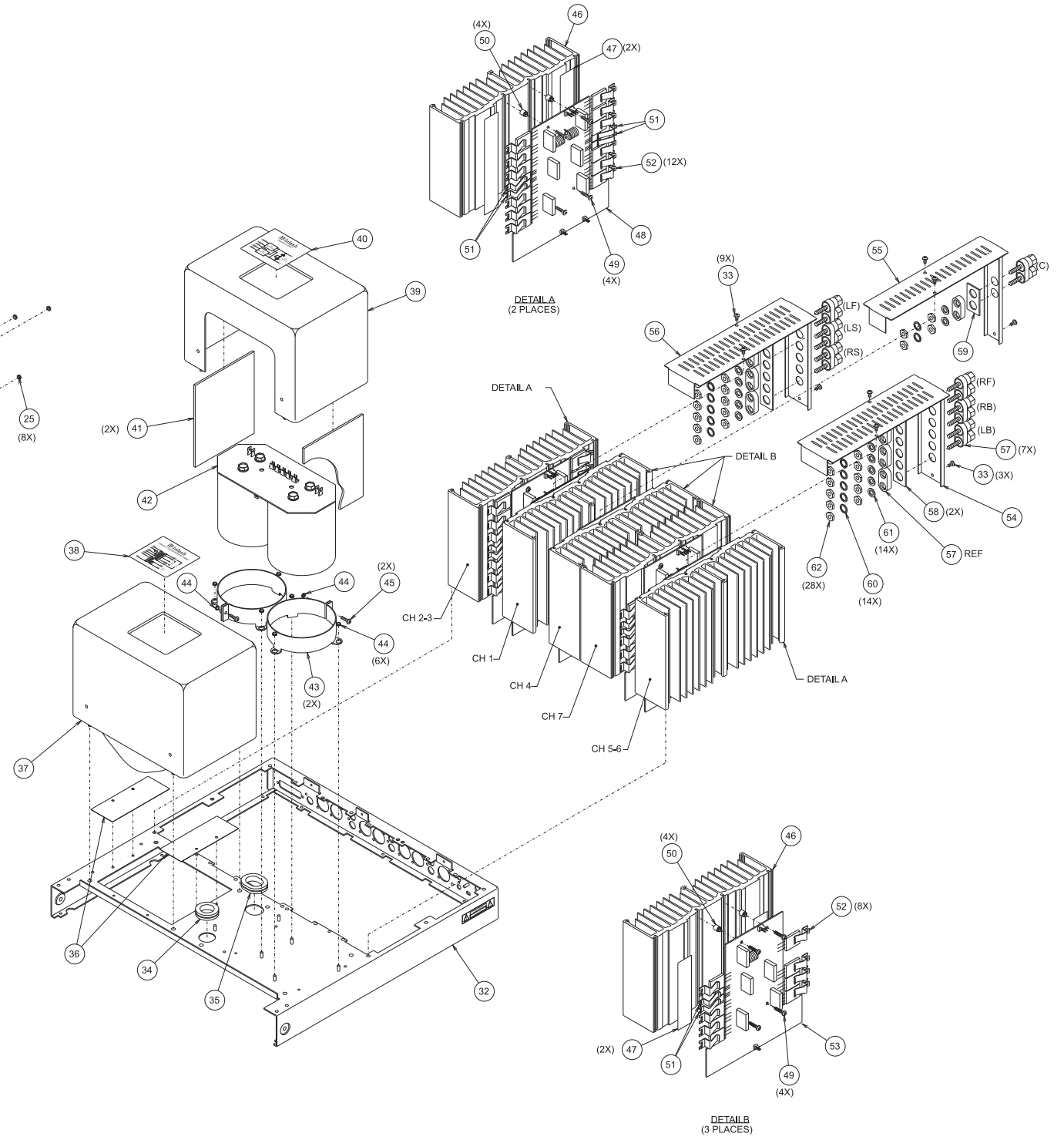
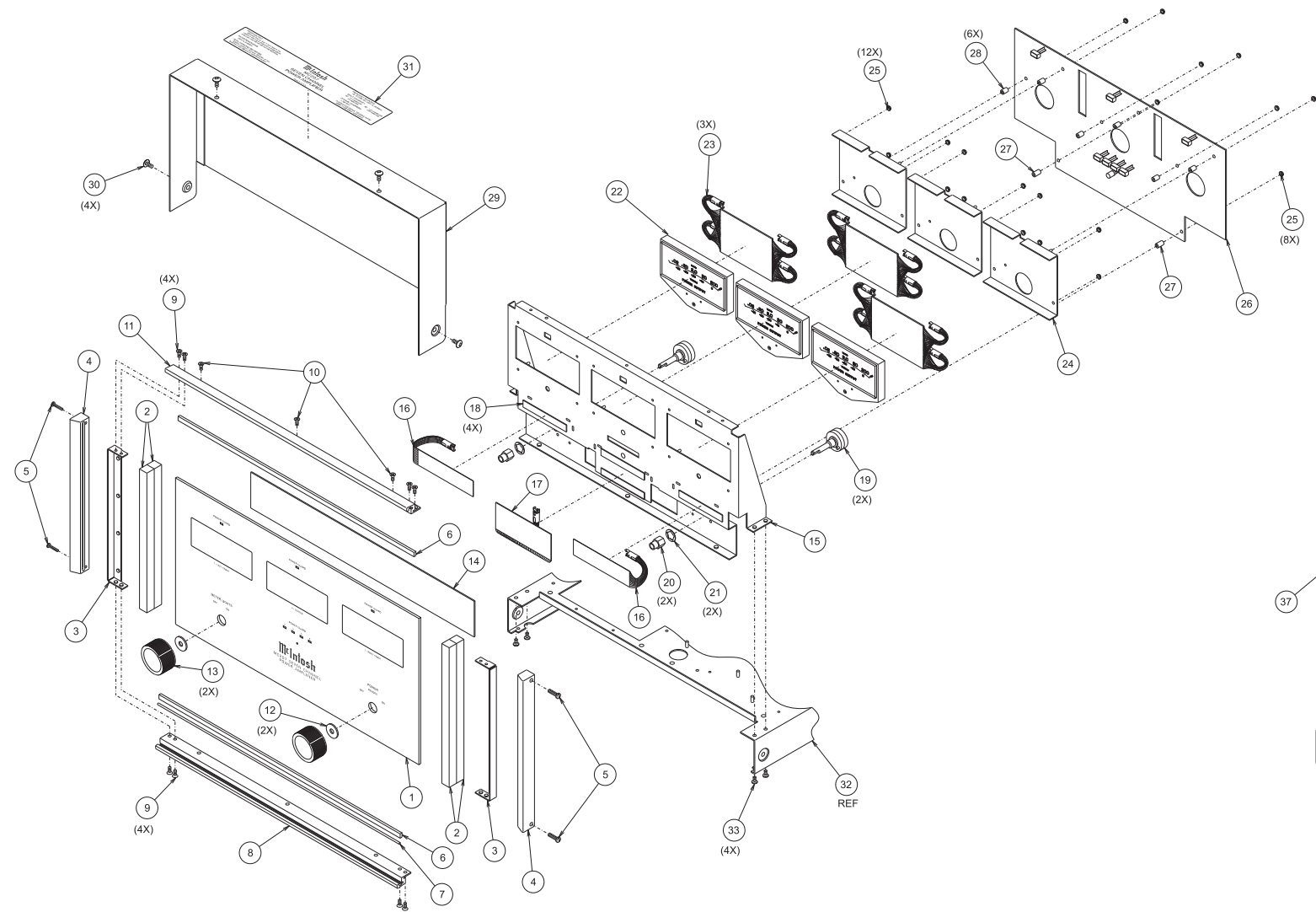

# MC207 EXPLODED VIEW and PARTS LIST

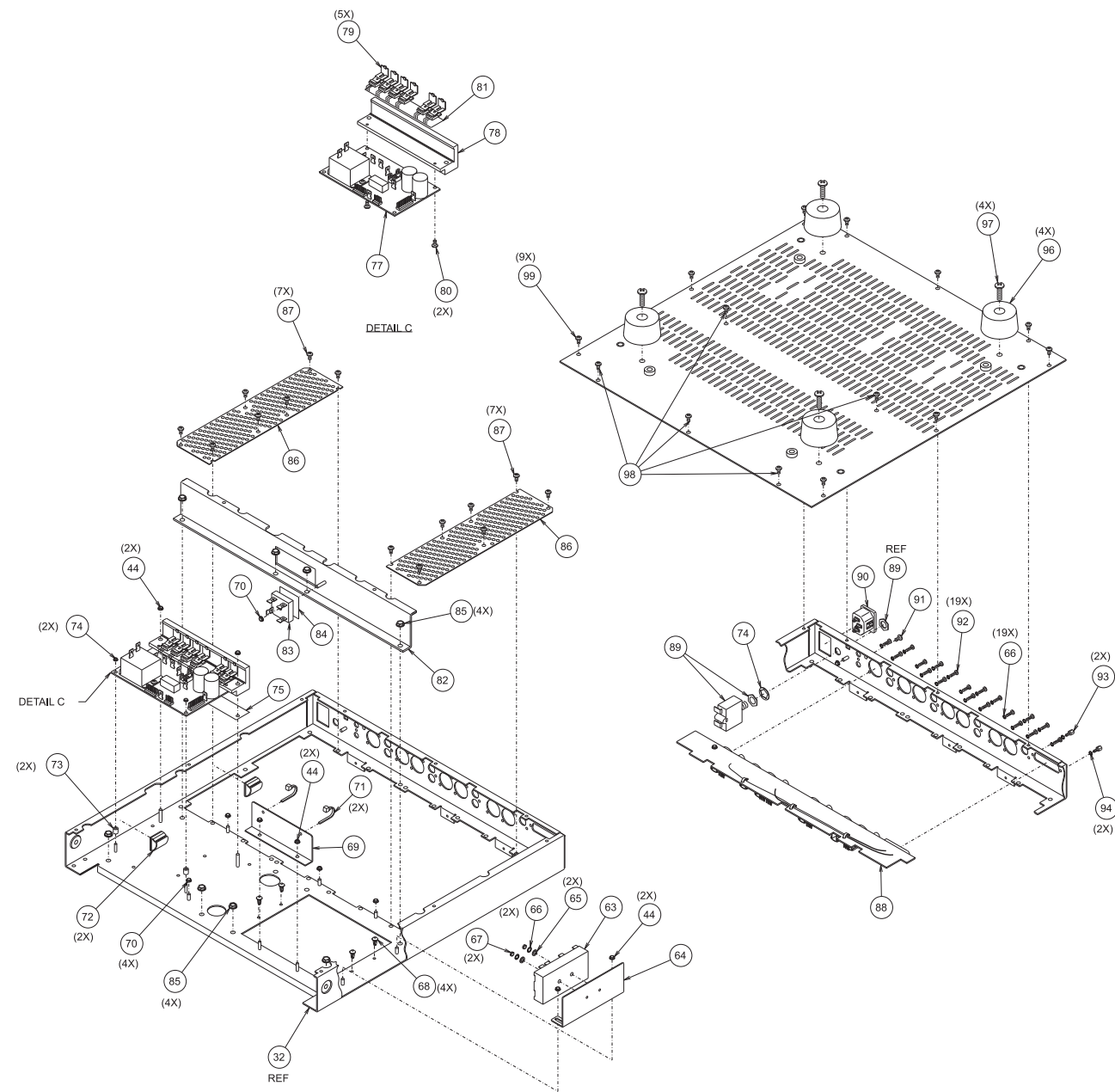

Ref No.	Part No.	Description	Ref No.	Part No.	Description
1	016507	GLASS	51	114118	TRANSISTOR CLIP 218
2	094360	TAPE FOAM 1/2 X 1/2	52	114119	TRANSISTOR CLIP 214
3	004939	BRACKET EXTRUSION	53	005007	ASSY HEATSINK PCB 1 CH
4	018615	END CAP 9"	54	005439	COVER HEATSINK CH 5-6
5	101042	SCREW TS 4-40 X 1/2 SLOT FILL	55	005406	HEATSINK COVER CENTER
6	094016	TAPE FOAM 1/4 X 1/8	56	005405	COVER HEATSINK CH 1-3
7	098113	CORD DIAL .027 BLACK BRAID SILK	57	084124	POST BINDING DUAL
8	018706	EXTRUSION BOTTOM	58	005419	OUTPUT PLATE TRIPLE
9	100149	SCREW MACH 6-32 X 1/4 FL U/H ST	59	005418	OUTPUT PLATE SINGLE
10	101232	SCREW 6-32 X 1/4 PH FLAT	60	104130	WASHER LOCK #10 SPLIT PHOS/BRNZ
11	018619	EXTRUSION TOP	61	104148	WASHER FLAT BRASS
12	104164	WASHER BLK FELT 1 X 1/4 X 1/16	62	110009	NUT M5 X 0.8 BRASS W/GOLD PLATE
13	049321	ASSY KNOB	63	074091	TERMINAL BLOCK AC
14	092413	ACETATE FILTER BLUE DISPLAY	64	005435	TERMINAL BRACKET
15	005407	SUBPANEL	65	104001	WASHER FLAT STEEL 4 X 9/32 X .025
16	017901	LOGO PUSHBUTTON BACKLIGHT	66	104142	WASHER LOCK 2.5mm INT STAR ZINC
17	017921	LOGO/SELECTOR BACKLIGHT	67	102022	NUT MACH 4-40 X 3/16 X 1/16
18	094429	FOAM TAPE WHITE 1/32" THK	68	114072	RIVET PLASTIC
19	146243	SWITCH POWER	69	005434	TRANSFORMER BRACKET
20	021159	BUSHING SWITCH	70	102003	NUT MACH 6-32 W/LOCK
21	104014	WASHER INT STAR 3/8 X .507 X .002	71	094255	CABLE TIE PANDUIT PLT1M-M
22	124089	METER MC207	72	017452	KLIP WIRE
23	017922	METER BACKLIGHT	73	021094	SPACER 4 X 1/4
24	005411	METER PLATE	74	104014	3/8 INT STAR WASHER
25	102001	NUT KEP 4-40 CADMIUM PLATE	75	084209	THERMSTRATE MC207
26	050066	ASSY METER/DISPLAY PCB	76	102020	NUT MACH 6-32 SELF LOCK
27	112038	SPACER STEEL 4 X 3/8L NCKL PLT	77	050062	ASSY POWER SUPPLY PCB
28	112060	SPACER 4 X 5/16 STEEL	78	018751	SUB HEATSINK
29	005404	DUST COVER	79	114141	CLIP RIGHT ANGLE
30	100287	SCREW MACH 8-32 X 3/8 PH TRUSS HD	80	100250	SCREW MACH SEMS 6-32 X 1/4 PH PN
31	126999	DECAL DUST COVER	81	084208	ISOSTRATE POWER SUPPLY
32	005408	CHASSIS	82	005410	CHASSIS SUPPORT REAR
33	101054	SCREW TAPTITE 6-32 X 1/4 PH PN BLK	83	070139	DIODE BRIDGE RECTIFIER
34	078024	GROMMET RUBBER 1" ID	84	084207	THERMAL PAD 1.25 X 1.25 ALUMINUM
35	078040	GROMMET 3/4" X 1"	85	102006	NUT MACH 10-32 W/LOCK
36	017956	TRANSFORMER SHIELD	86	005401	HEATSINK VENT
37	050061	POTTED TRANSFORMER POWER	87	101176	SCREW TC 6-32 X 1/2 PH PN TYPE F
38	166001	DECAL POWER TRANSFORMER	88	005065	ASSY INPUT PCB
39	050090	CAN POTTED CAPACITOR	89	088023	CIRCUIT BREAKER 10A 240VAC
40	166002	DECAL CAPACITOR COVER	90	117487	RECEPTACLE AC LINE
41	094450	SOUND DAMPING PAD MC207	91	100250	SCREW MACH SEMS 6-32 X 1/4 PH PN
42	050063	ASSY CAPACITOR PCB	92	101197	SCREW HI-LO 4-24 X 3/8 PH RD BLK
43	005413	CAPACITOR CLAMP	93	112015	STANDOFF
44	102045	NUT KEP 6-32 X 1/2 PH PN	94	104004	WASHER LOCK 5 X .255 INT STAR
45	100118	SCREW MACH 6-32 X 1/2 PH PN	95	005400	BOTTOM COVER
46	018750	HEATSINK	96	017937	FOOT
47	084183	ISOSTRATE	97	100159	SCREW MACH 10-32 X 3/4 PH PN
48	050064	ASSY HEATSINK PCB 2 CH	98	101078	ST 8-32 X 5/16 PH PN
49	101059	SCREW SM 6 X 5/8 PH PN TYPE A	99	100173	MS 8-32 X 1/4 PH PN
50	112087	SPACER PCB 1/4"			

# REPACKING INSTRUCTION

In the event it is necessary to repack the unit for shipment, the unit must be packed exactly as shown below.

*IMPORTANT - For ease of shipment, attach the four feet to the bottom of the unit. Four, 1/4 - 20 x 2-1/4 bolts with washers must be used to fasten the unit securely to the wood skid. Failure to do this will result in shipping damage.*

If a shipping carton or any of the interior parts is needed, please call or write the Customer Service Department of McIntosh Laboratory. Order parts from the accompanying list by part number.

Use the original shipping carton and interior parts only if they are in good serviceable condition.

Qty.	Part No.	Description
1	034051	Shipping carton bottom
2	034186	Foam pad (front and rear)
2	034187	Foam Pad (side)
2	034054	Foam pad (top and bottom)
1	034052	Shipping carton (top)
1	034137	Inner carton (bottom)
1	034264	Shipping skid
1	034188	Foam pad (inner carton)
1	034136	Inner carton (top)
4	101212	1/4 - 20 x 2-1/4 cap screw
4	104058	Flat washer

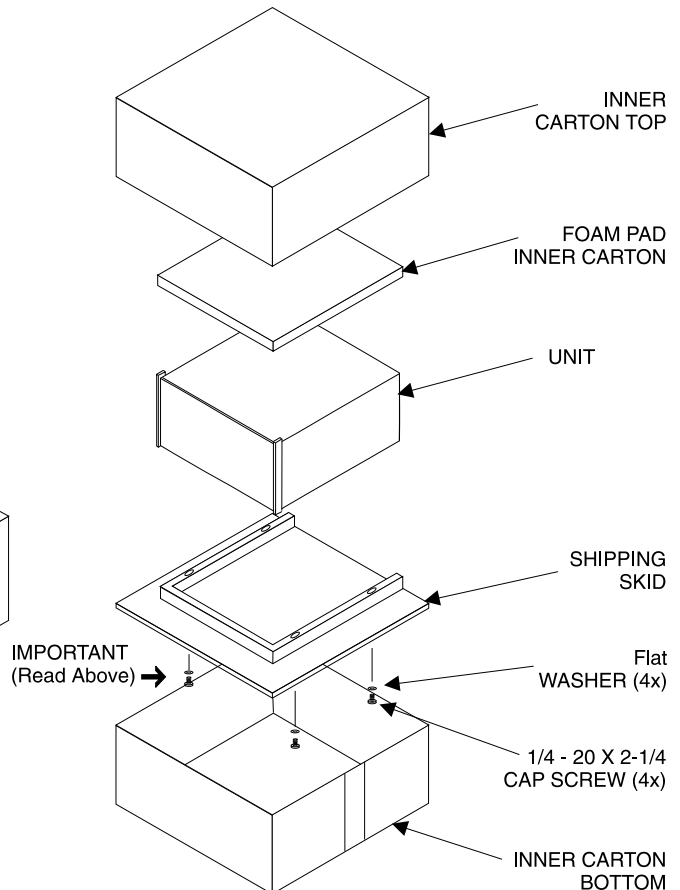
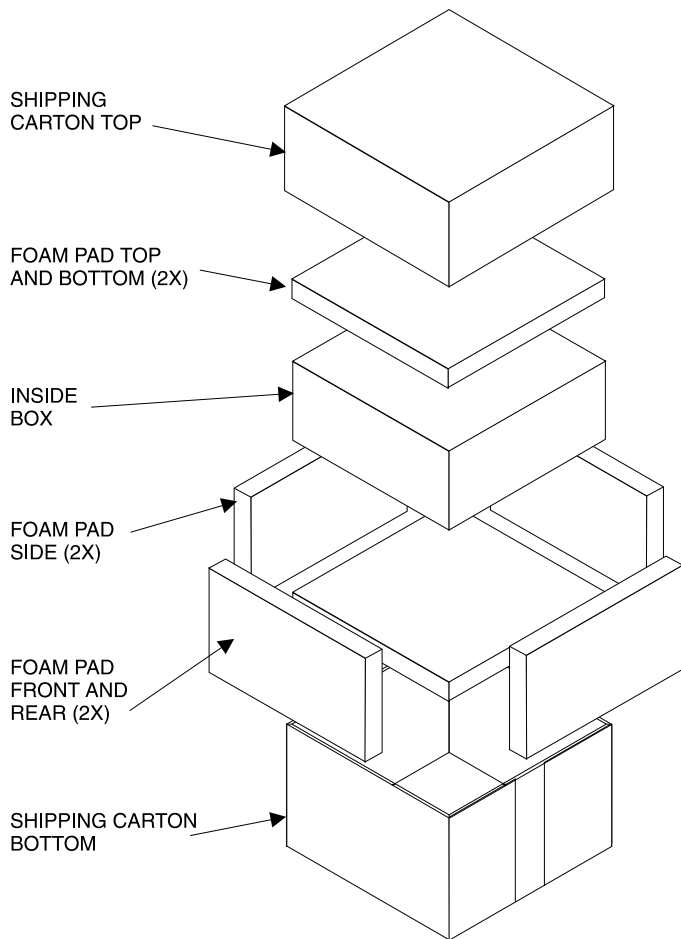

# MC207

## POWER AMPLIFIER

### SERVICE MANUAL

SERIAL NO. VQ1001 And Above



The continuous improvement of its products is the policy of McIntosh Laboratory Incorporated, who reserve the right to improve design without notice. Because of the constant upgrading of McIntosh products' circuitry and components, the Company cannot insure, and does not warrant, the accuracy of the within schematic material, which is intended for information only.