

McIntosh

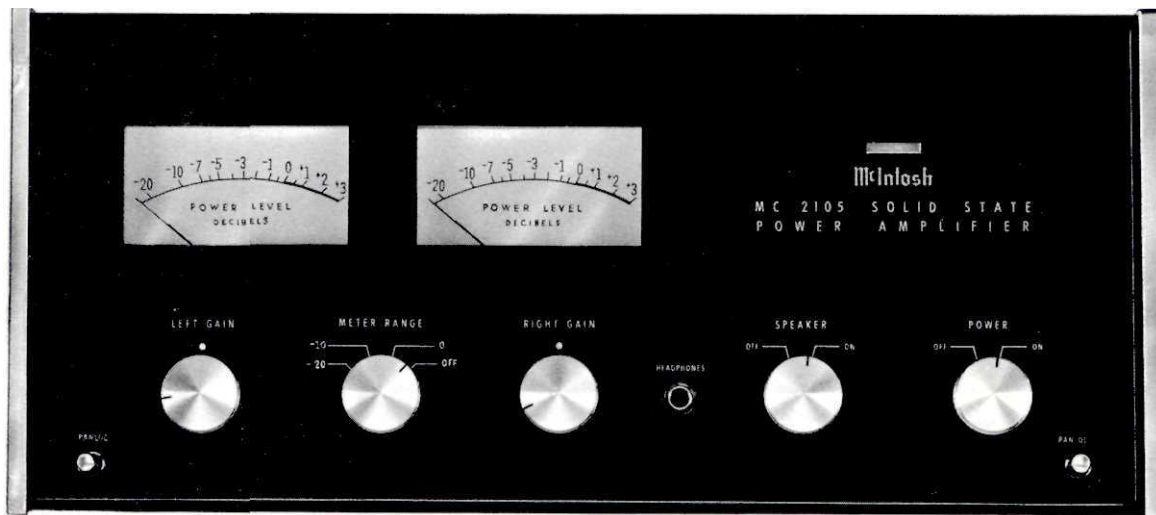

FROM SERIAL NO. 10M01 TO 26M07

McINTOSH LABORATORY INC. 2 CHAMBERS STREET BINGHAMTON, NEW YORK

MC 2105

ELECTRICAL SPECIFICATIONS

POWER OUTPUT:

105 RMS watts continuous per channel into 4, 8, or 16 ohms both channels operating.

HARMONIC DISTORTION:

Less than 0.25% at 105 watts power output from 20 Hz to 20 kHz, both channels operating. Typical performance is less than 0.1% at rated power. Distortion decreases as output is reduced.

INTERMODULATION DISTORTION:

Less than 0.25% if instantaneous peak power output is 210 watts or less per channel with both channels operating for any combination of frequencies 20 Hz to 20 kHz.

FREQUENCY RANGE:

20 Hz to 20 kHz +0, -0.1 dB at rated power.
15 Hz to 60 kHz +0, -0.5 dB at rated power.
10 Hz to 100 kHz +0, -3.0 dB at rated power.

NOISE AND HUM:

90 dB or more below rated output.

OUTPUT IMPEDANCE:

4, 8, and 16 ohms

OUTPUT VOLTAGES:

25 volts (connect to 8 ohm outputs.)

DAMPING FACTOR:

18 at 4 ohms output
13 at 3 ohms output
10 at 16 ohms output

INPUT IMPEDANCE:

200,000 ohms

INPUT SENSITIVITY:

0.5 volts. Level control provided for higher input voltage.

POWER REQUIREMENTS:

117 volts AC 50-60 Hz, 90 watts at zero signal output, 450 watts at rated output.

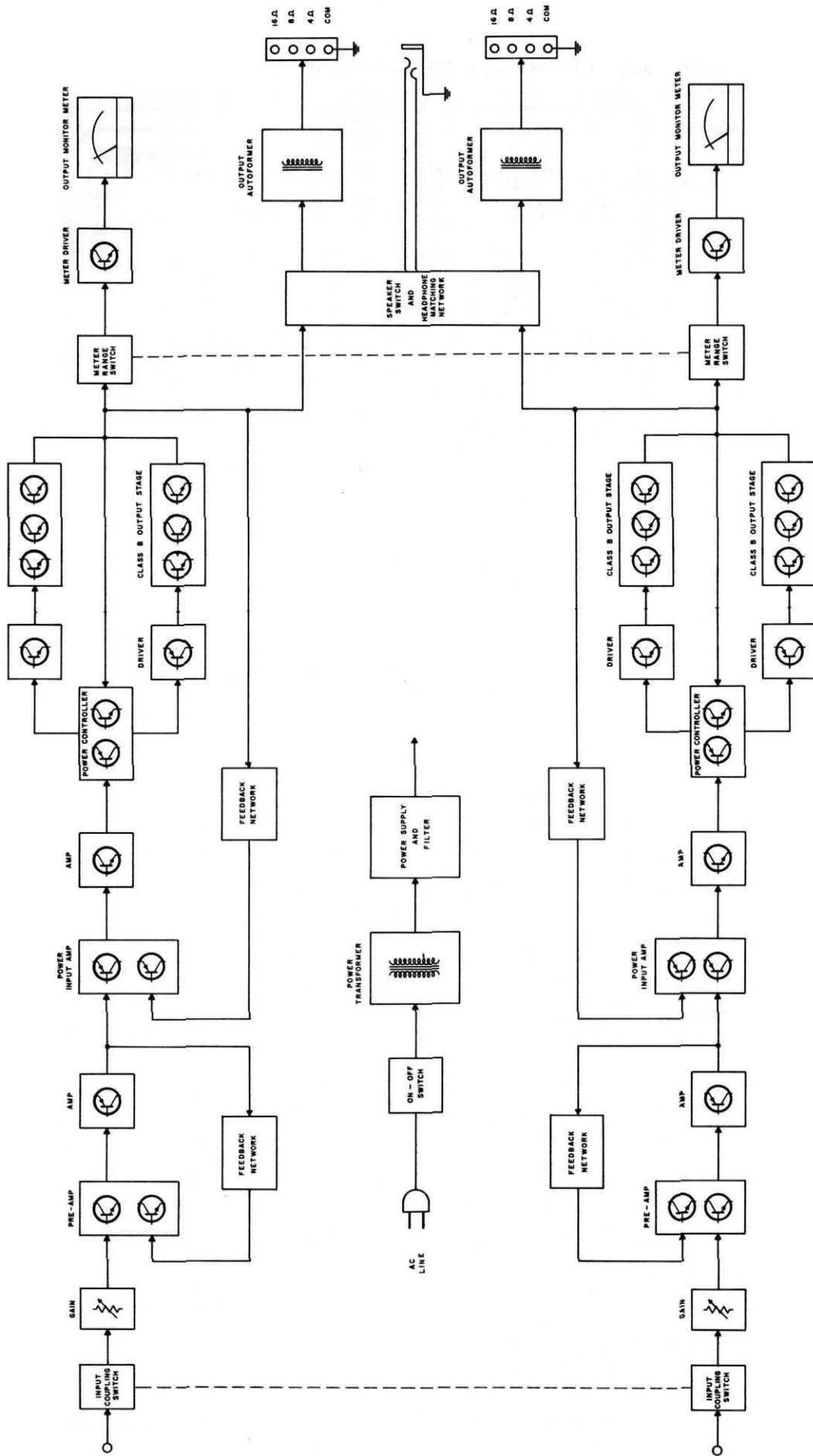

INPUT SECTION PRINTED CIRCUIT BOARD 043-795

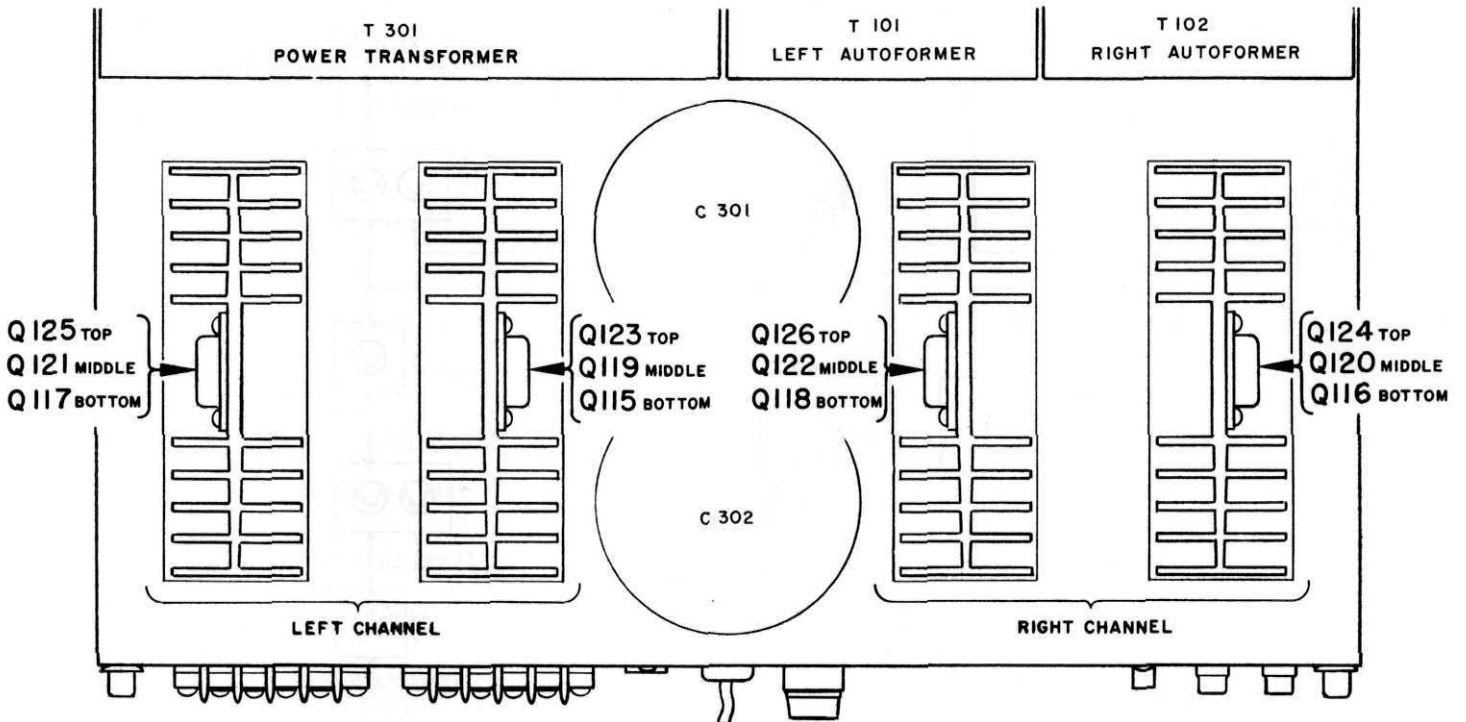
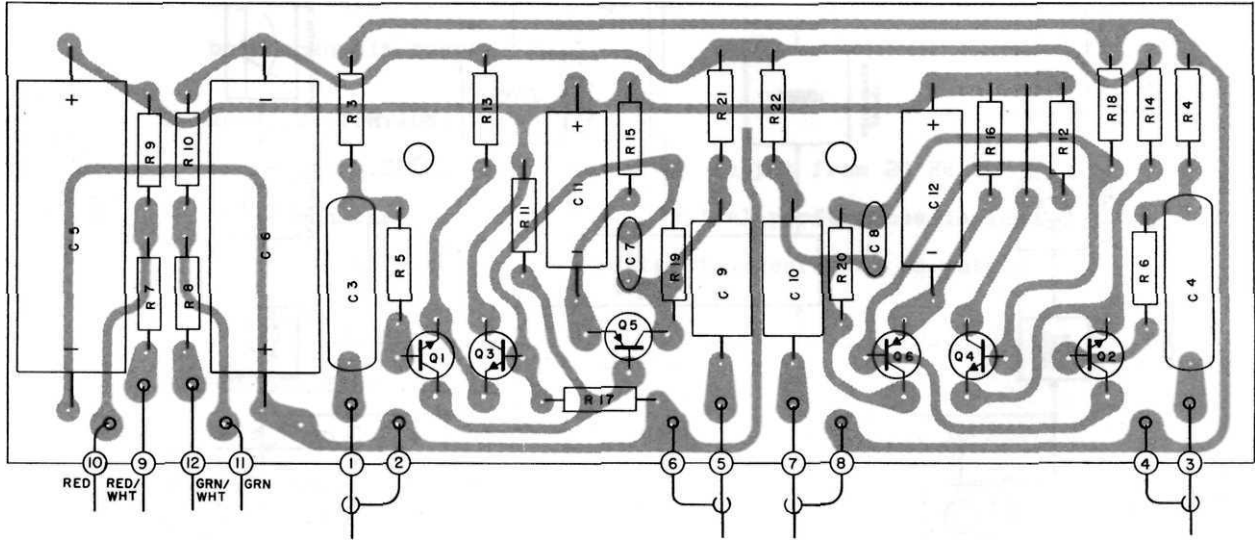

LOCATION OF TRANSISTORS NOT ON PRINTED CIRCUIT BOARDS

INPUT SECTION PRINTED CIRCUIT BOARD 043-795

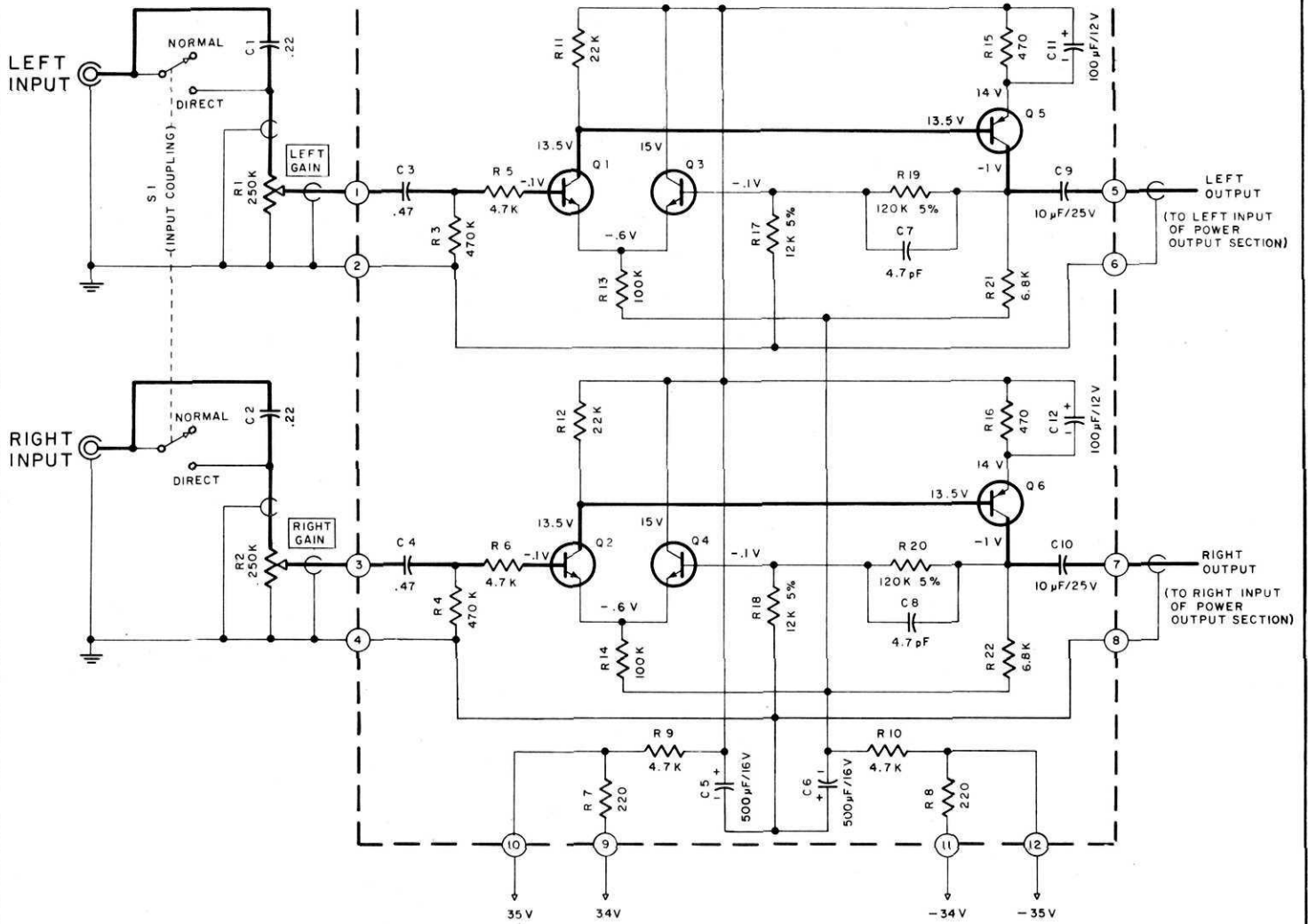

HEAVY LINE SHOWS PRIMARY SIGNAL PATH

INPUT SECTION

MC2105

154-292

LEFT CHANNEL
POWER OUTPUT SECTION PRINTED CIRCUIT BOARD 043-805

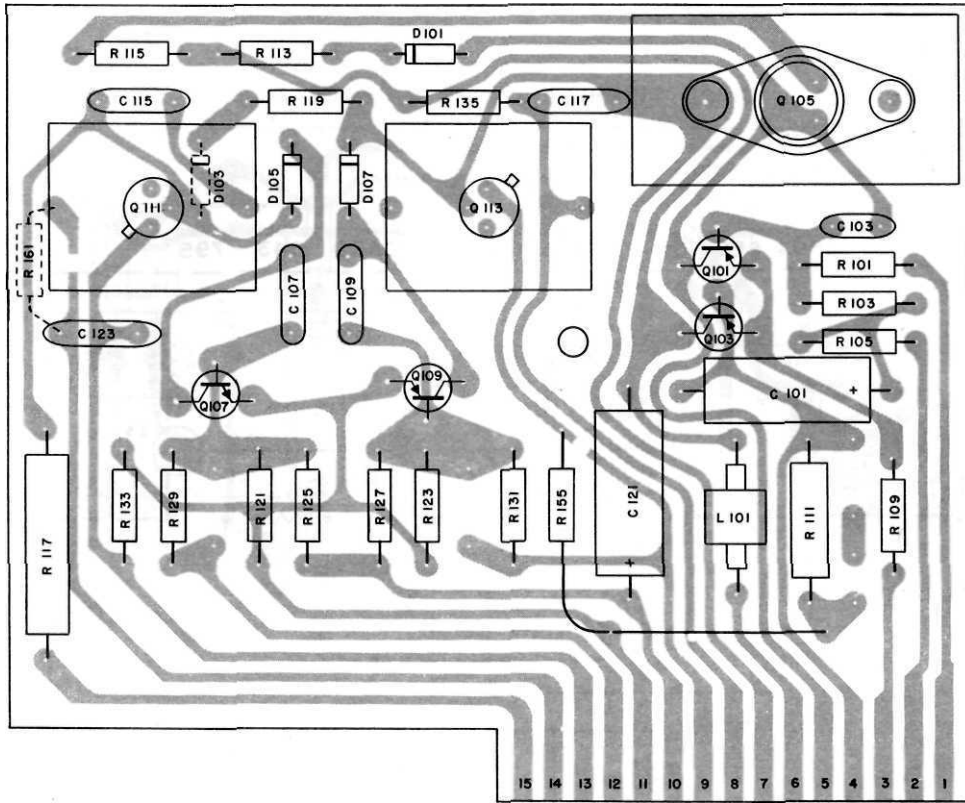

RIGHT CHANNEL
POWER OUTPUT SECTION PRINTED CIRCUIT BOARD 043-805

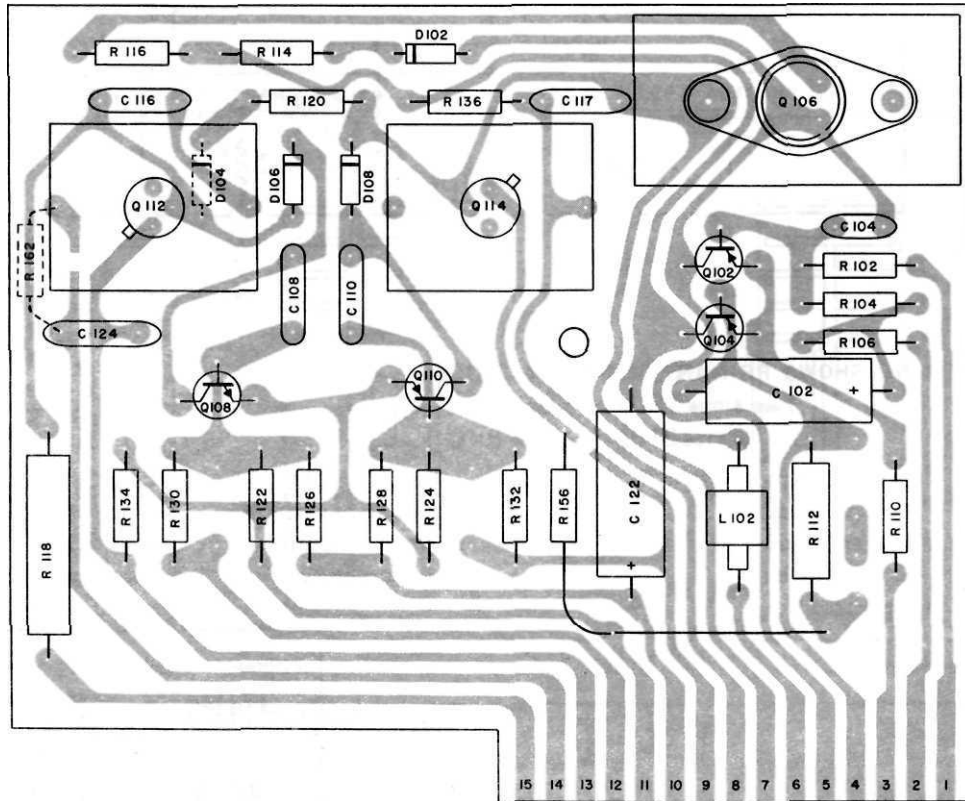

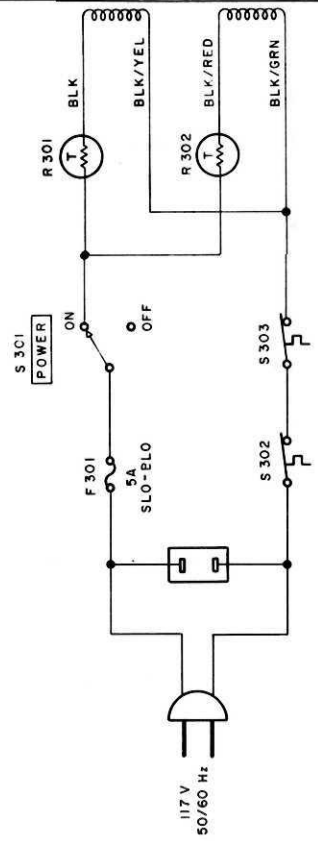
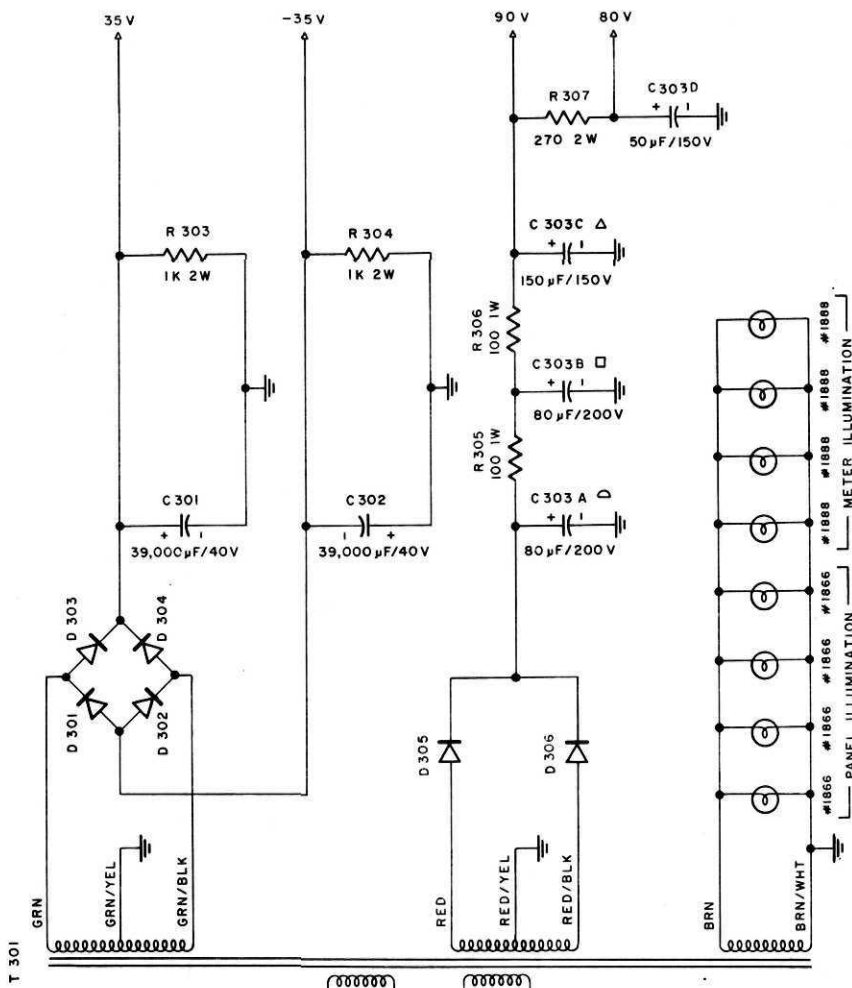

POWER SUPPLY SECTION

LEFT CHANNEL POWER OUTPUT SECTION PRINTED CIRCUIT BOARD 043-805

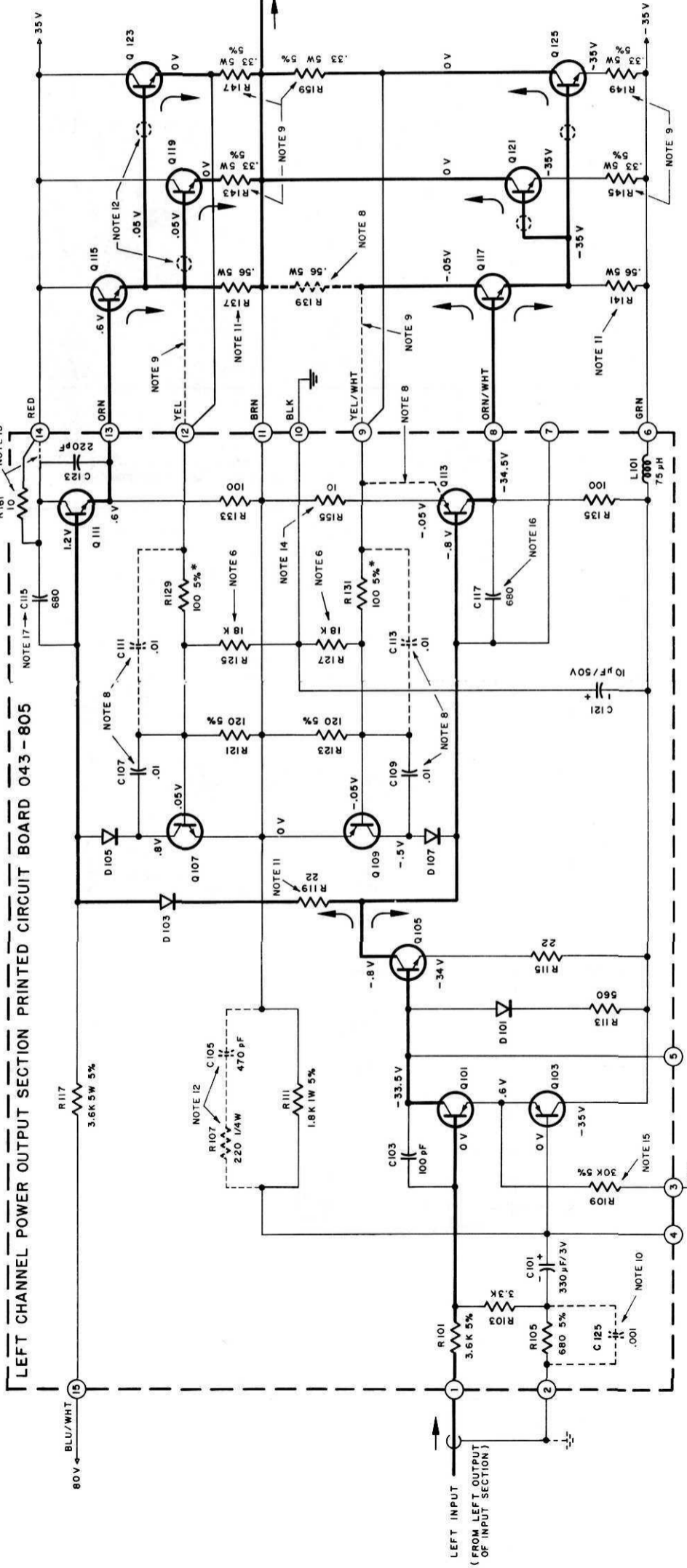

LEFT CHANNEL
OUTPUT

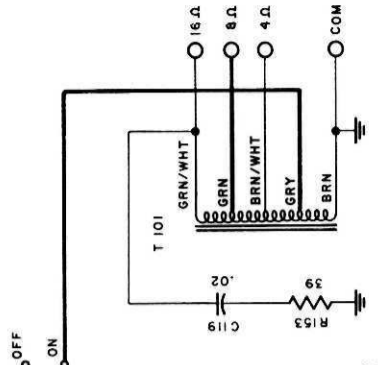

HEADPHONES

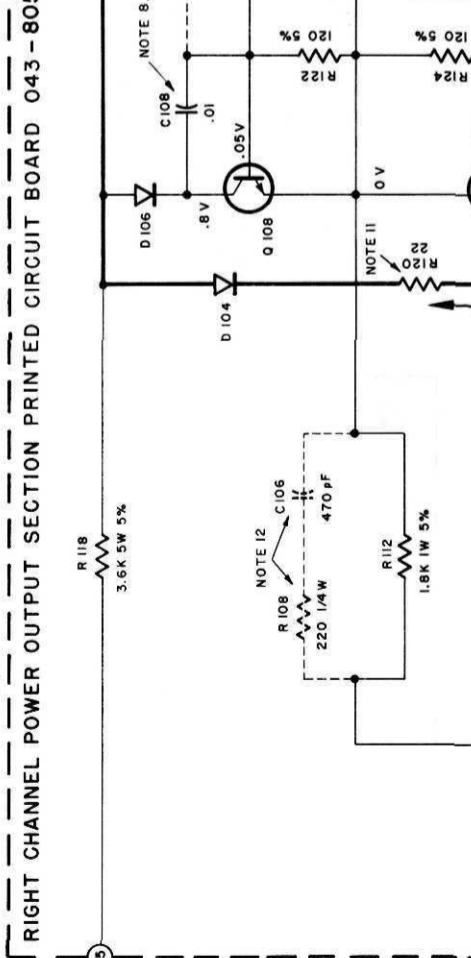

RIGHT CHANNEL
OUTPUT

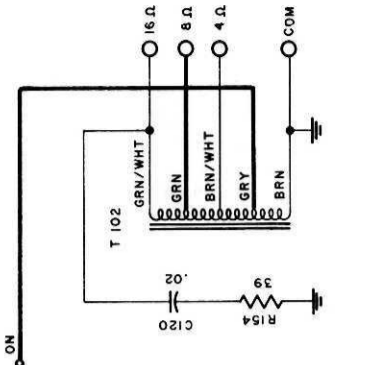

HEAVY LINE SHOWS PRIMARY SIGNAL PATH

POWER OUTPUT
SECTION

* ACTUAL VALUE FACTORY SELECTED; NORMAL VALUE SHOWN.

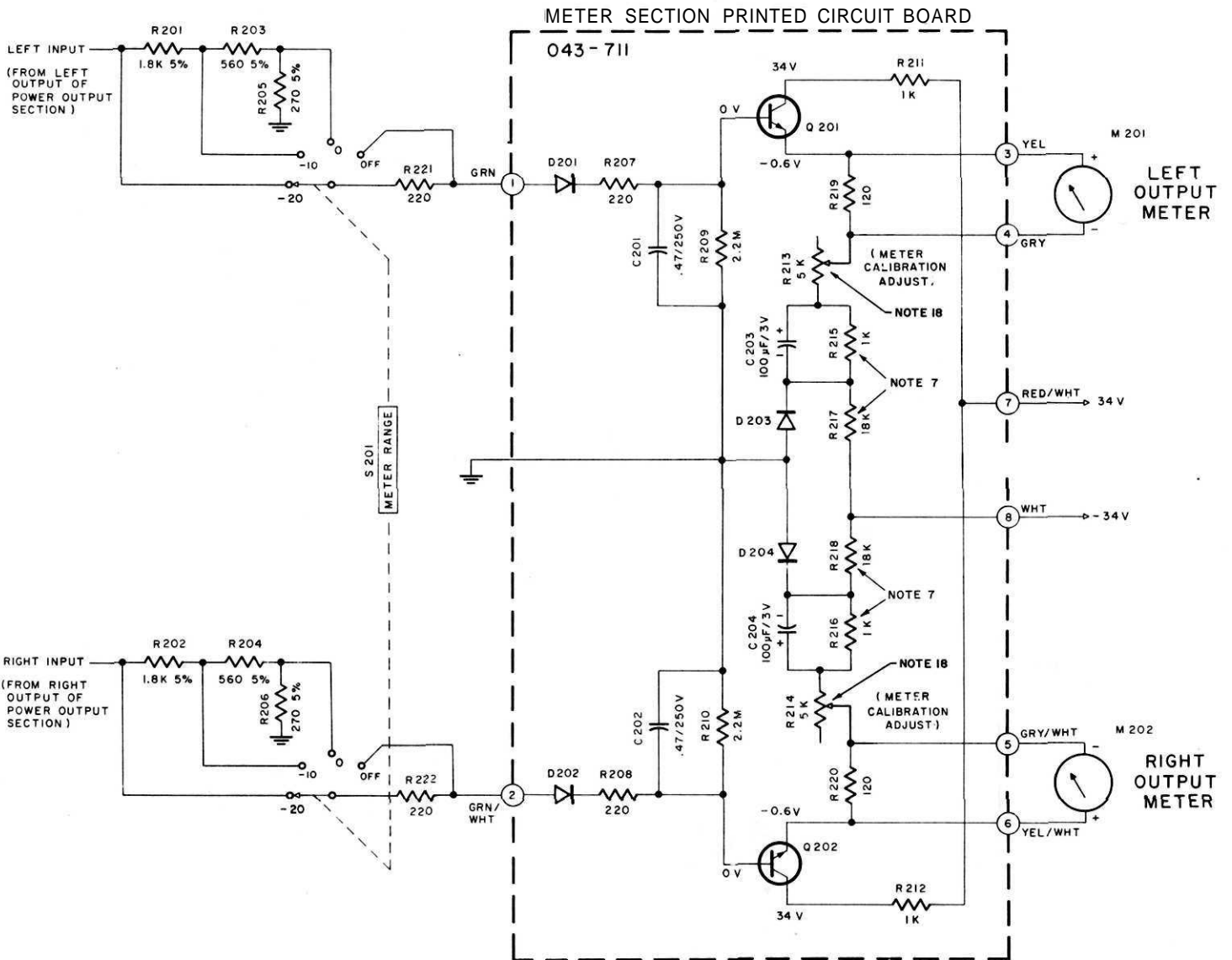

METER SECTION

MC 2105

154-294

SCHEMATIC NOTES

1. Unless otherwise specified: Resistance values are in ohms, 1/2 watt, and 10% tolerance; capacitance values smaller than 1 are in microfarads (μf); capacitance values greater than 1 are in picofarads (pF); inductors are in microhenries (μH).
2. Printed circuit board components are outlined on the schematics by dotted lines. The circled numbers on the dotted lines correspond to the numbers on the PC board layouts.
13. The heavy lines on the schematics denote the primary signal path.
4. The terminal numbering of rotary switches is for reference only.
5. All voltages indicated on the schematics are measured under the following conditions:
 - a. Use of an 11 megohm impedance VTVM.
 - b. All voltages $\pm 10\%$ with respect to chassis ground.
 - c. No signal at input terminals.
 - d. AC input at 117 volts AC, 50/60Hz.
 - e. Front panel controls at:

Left Gain	FULLYCCW
Meter Range	OFF
Right Gain	FULLYCCW
Speakers	ON
Power	OH
6. R125, R126, R127, and R128 are 2.7K in early units.
7. R215 and R216 are 1.2K and R217 and R218 are 22K in early units.
8. In units with serial No's below 10M40: C111, C112, C113, and C114, are used; C107, C108, C109, and C110 (part No. 064-044) are .047; The emitter of Q113 and Q114 is connected as shown by the dotted line; R139 and R140 (part No. 139-061) are used.
9. In units with serial No's below 11M93: R159 and R160 are not used; R143, R144, R145, R146, R147, R148, R149, and R150 are .15W (part No. 139-055); pins Ho. 12 and 9 on PC boards are connected as shown by dotted line.
10. C125 and C126 are used in units with serial No's from 11M93 to 13M05.
11. R137f R138, R141, and R142 are 75ohm9W 10% (part No. 139-070) and R119 and R120 are 2751 in early units.
12. In units with serial No's below 20M01; R107, R108, C105, and C106 are used; ferrite beads (part No. 076-010) are not used.
13. In units with serial No's below 20M50 R161 and R162 are not used and pin 14 is connected as shown by dotted line.
14. R155 and R156 are 8.2ohm 10% in units with serial No's from 10M40 to 21M13.
15. R109, 110 is 47K in units with serial No's from 11M93 to 23M25.
16. In units with serial No's below 10M40; C117 and C118 are .0012. In units with serial No's from 10M40 to 23M25, C117 and C118 are not used.
17. In units with serial No's below 23M25, C115 and C116 are .0012.
18. Adjust meter calibration controls R213 (left channel) and R214 (right channel) so output meters indicate +3dB when meter range switch is in the "0" position and the amplifier is delivering 105 watts output.

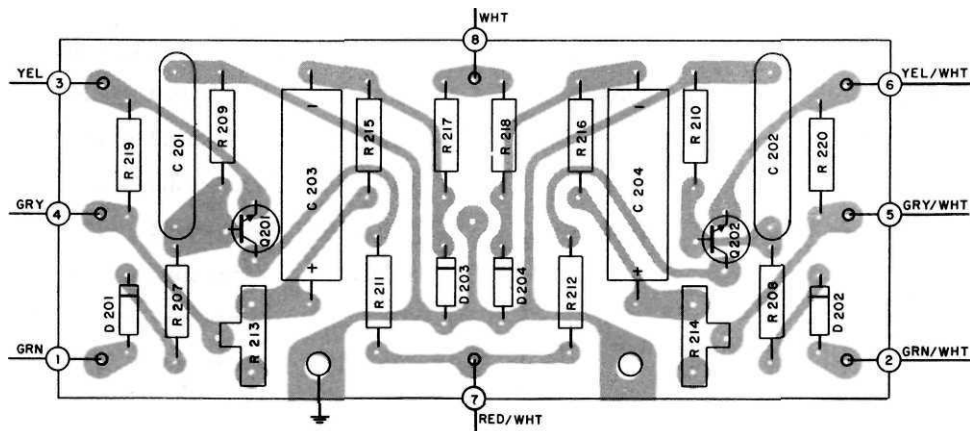

METER SECTION PRINTED CIRCUIT BOARD 043-711

REPLACEMENT PARTS

All parts not listed are common items obtainable from radio parts jobbers.

Replacement parts may be obtained when ordered by PART NUMBER from:

McIntosh Laboratory Inc.
Customer Service Department
2 Chambers Street
Binghamton, New York 13903
(telephone 607-723-3512)

CAPACITORS

Symbol Number	Description	Part Number
C1,2	Mylar .22uF 250V	064-043
C3,4	Mylar .47uF 250V	064-045
C5,6	Elect. 500uF 16V	066-107
C9,10	Elect. 10uF 25V NP	066-005
C11,12	Elect. 100uF 15V	066-127
C101,102	Elect. 330uF 3V	066-105
C121,122	Elect. 10uF 50V	066-113
C201,202	Mylar .47uF 250V	064-045
C203,204	Elect. 100uF 3V	066-047
C301	Elect. 39,000uF 40V	066-119
C302	Elect. 39,000uF 40V	066-119
C303	Elect. 80/80/150/50uF 200/200/150/150V	066-095

DIODES

D101,102	Si. signal diode	070-022
D103,104	Si. reference diode	070-040
D105,106	Si. signal diode	070-022
D107,108	Si. signal diode	070-022
D201,202	Ge. signal diode	070-003
D203,204	Ge. signal diode	070-003
D301,302	Rectifier Assy (Black)	043-903
D303,304	Rectifier Assy (Red)	043-904
D305	Si. rectifier	070-031
D306	Si. rectifier	070-031

PUSES

P301	Fuse 5 ampere Slo-Blo	089-007
------	-----------------------	---------

CHOKES

L101,102	Choke 75uH	122-013
----------	------------	---------

METERS

M201,202	Meter (power level)	124-013
----------	---------------------	---------

- TRANSISTORS

Q1,2	Si. NPN transistor	132-054
Q3,4	Si. NPN transistor	132-054
Q5,6	Si. PNP transistor	132-031
Q101,102	Si. PNP transistor	132-031
Q103,104	Si. PNP transistor	132-031
Q105,106	Si. NPN transistor	132-515
Q107,108	Si. NPN transistor	132-021
Q109,110	Si. PNP transistor	132-032
Q111,112	Si. NPN transistor	132-038
Q113,114	Si. PNP transistor	132-039
Q115,116	Si. NPN transistor (Below Serial No. 20M01)	132-518
Q115,116	Si. NPN transistor (Above Serial No. 20M01)	132-541
Q117,118	Si. NPN transistor (Below Serial No. 20M01)	132-518
Q117,118	Si. NPN transistor (Above Serial No. 20M01)	132-541
Q119,120	Si. NPN transistor (Below Serial No. 20M01)	132-517
Q119,120	Si. NPN transistor (Above Serial No. 20M01)	132-541
Q121,122	Si. NPN transistor (Below Serial No. 20M01)	132-517
Q121,122	Si. NPN transistor (Above Serial No. 20M01)	132-541
Q123,124	Si. NPN transistor (Below Serial No. 20M01)	132-517
Q123,124	Si. NPN transistor (Above Serial No. 20M01)	132-542
Q125,126	Si. NPN transistor (Below Serial No. 20M01)	132-517
Q125,126	Si. NPN transistor (Above Serial No. 20M01)	132-542
Q201,202	Si. NPN transistor	132-054

POTENTIOMETERS

R1,2	Gain controls	134-191
R213,214	Meter calibration adjust	134-120

RESISTORS

R117,118	Wirewound 3.6K 5% 5W	139-065
R137,138	Wirewound .56 ohms 5W	139-061
R141, 142	Wirewound .56 ohms 5W	139-061
R143,144	Wirewound .33 ohms 5W	139-071
R145,146	Wirewound .33 ohms 5W	139-071
R147,148	Wirewound .33 ohms 5W	139-071
R149,150	Wirewound .33 ohms 5W	139-071
R159-160	Wirewound .33 ohms 5W	139-071
R301,302	Thermistor	144-012

SWITCHES

31	Input coupling switch	148-006
S101	Speaker switch	146-103
S201	Meter range switch	146-109
S301	Power on-off switch	146-102
S302,303	Thermal cut-out	153-007

TRANSFORMERS

T101,102	Output transformer	043-649
T301	Power transformer	043-693

FRONT PANEL AND TRIM

Front panel		043-735
Front panel end caps		018-112
Knobs (all controls)		043-253

LAMPS

#1866 (for wording)		058-014
#1888 (for meters)		058-029

PANLOC SYSTEM

Shelf bracket (right)		043-678
Shelf bracket (left)		043-679
Mounting template #300		038-161
Hardware package		043-691

MISCELLANEOUS ITEMS

Plastic feet		017-041
Shipping carton		043-793
Owners manual		038-163
Line cord		170-021

