

McIntosh

MC 2120 POWER AMPLIFIER

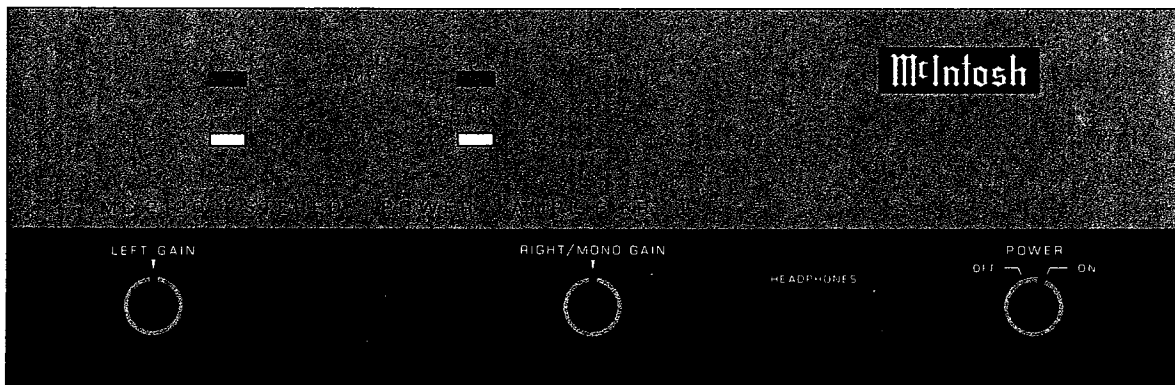

SERVICE INFORMATION

STARTING WITH SERIAL NO. AW1001

MCINTOSH LABORATORY INC. BINGHAMTON, NEW YORK 13903

038-920

 PERFORMANCE

McIntosh audio power ratings are in accordance with the Federal Trade Commission Regulation of November 4, 1974 concerning power output claims for amplifiers used in home entertainment products.

POWER OUTPUT

STEREO: 120 watts minimum sine wave continuous average power output, per channel, both channels operating into 2 ohms, 4 ohms, 8 ohms, or 16 ohms load impedance, which is:

15.5 volts RMS across 2 ohms
 21.9 volts RMS across 4 ohms
 31.0 volts RMS across 8 ohms
 43.8 volts RMS across 16 ohms

MONO: 240 watts minimum sine wave continuous average power output into 1 ohm, 2 ohms, 4 ohms, or 8 ohms load impedance, which is:

15.5 volts RMS across 1 ohm
 21.9 volts RMS across 2 ohms
 31.0 volts RMS across 4 ohms
 43.8 volts RMS across 8 ohms

OUTPUT LOAD IMPEDANCE

STEREO: 2 ohms, 4 ohms, 8 ohms, and 16 ohms; separate terminals are provided for each output.

MONO: 1 ohm, 2 ohms, 4 ohms, and 8 ohms; obtained by connecting together appropriate terminals of both channels.

RATED POWER BAND

20 Hz to 20,000 Hz

TOTAL HARMONIC DISTORTION

STEREO: 0.1% maximum harmonic distortion at any power level from 150 milliwatts to 120 watts per channel from 20 Hz to 20,000 Hz, both channels operating

MONO: 0.1% maximum harmonic distortion at any power level from 150 milliwatts to 240 watts from 20 Hz to 20,000 Hz

INTERMODULATION DISTORTION

STEREO: 0.1% maximum if instantaneous peak power output is 240 watts or less per channel with both channels operating for any combination of frequencies, 20 Hz to 20,000 Hz

MONO: 0.1% maximum if instantaneous peak power output is 480 watts or less for any combination of frequencies, 20 Hz to 20,000 Hz

FREQUENCY RESPONSE

(at one watt output)

20 Hz to 20,000 Hz, +0 -0.25 dB
 10 Hz to 100,000 Hz, +0 -3.0 dB

NOISE AND HUM

95dB below rated output

 RATINGS

OUTPUT VOLTAGES

25 volts for distribution lines

DAMPING FACTOR

STEREO: 16 at 2 ohms output, 50 at 4 ohms output, 20 at 8 ohms output, 14 at 16 ohms output

MONO: 16 at 1 ohm, 50 at 2 ohms, 20 at 4 ohms, and 14 at 8 ohms output

INPUT IMPEDANCE

100,000 ohms

INPUT SENSITIVITY

Switchable: 0.75 volt or 2.5 volts-
 Level control provided for higher input voltages

POWER REQUIREMENTS

120 volts 50/60Hz, 50 to 460 watts.

SCHEMATIC NOTES

1. Unless otherwise specified: Resistance values are in ohms, 1/4 watt, and 10% tolerance; capacitance values smaller than 1 are in microfarads (μF); capacitance values greater than 1 are in picofarads (pF); inductors are in microhenries (μH).
2. Printed circuit board components are outlined on the schematics by dotted lines. The circled numbers on the dotted lines correspond to the numbers on the PC board layouts.
3. The heavy lines on the schematics denote the primary signal path.
4. The terminal numbering of rotary switches is for reference only.
5. All voltages indicated on the schematics are measured under the following conditions:
 - a. Use of an 11 megohm impedance VTVM.
 - b. All voltages $\pm 10\%$ with respect to chassis ground.
 - c. No signal at input terminals.
 - d. AC input at 120 volts AC, 50/60Hz.

e. Front panel controls at:

Left Gain	FULLY CCW
Right/Mono Gain	FULLY CCW
Power	ON

Rear panel switches at:

Input Level	0.75V
Mode	Stereo
Power Guard	Normal

6. Relay K301 shown in energized position.
7. Power amplifier bias adjustment:

Operate MC 2120 at 120 volts line input with no input signal. Measure the input power (approximately 50 watts) or current (approximately 0.4 amps). The bias potentiometers R241 & R242 are located on the power output PC boards.

- a. Turn both bias potentiometers full ccw
- b. Rotate bias adjustment cw to the point where the line input power or current increases by 6 watts or .05 amps.
- c. Repeat step b for each channel independently.

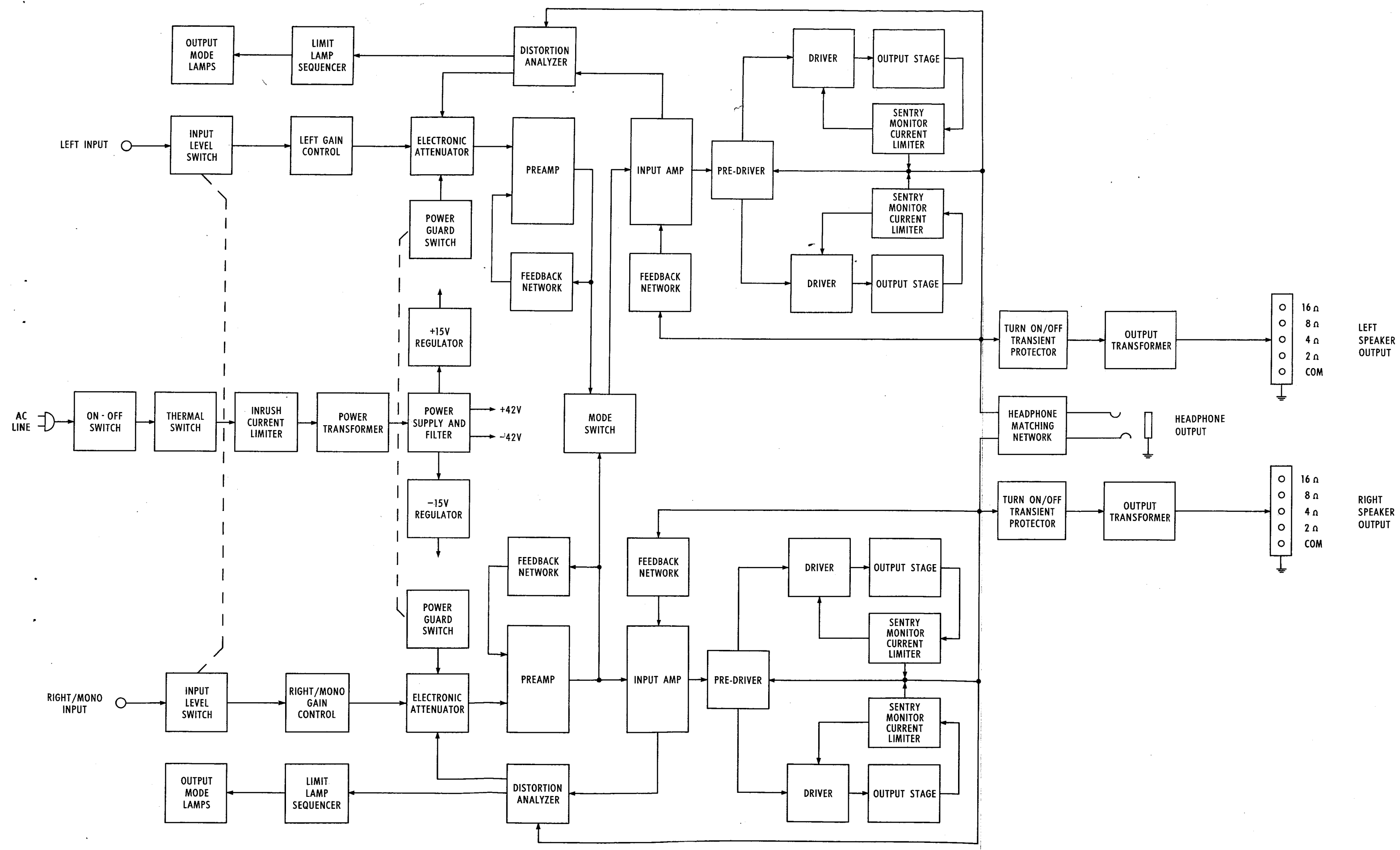

BLOCK DIAGRAM

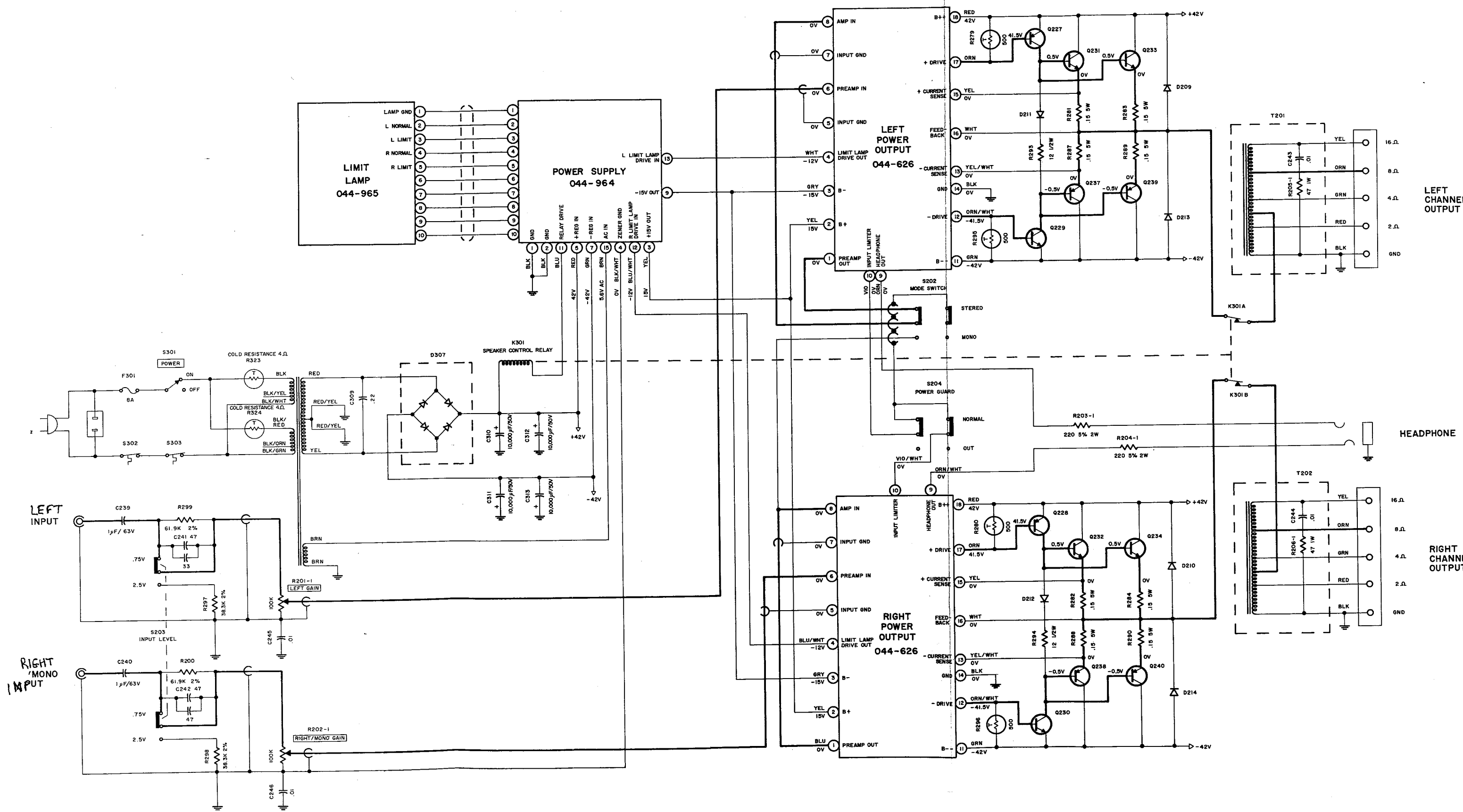

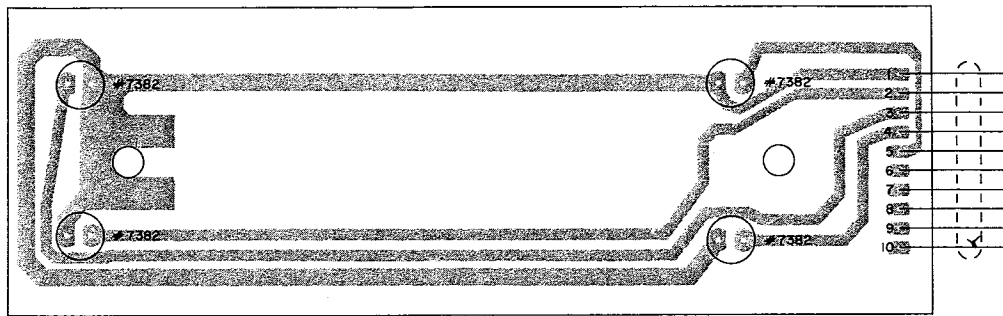

LIMIT LAMP PC BOARD 054-486

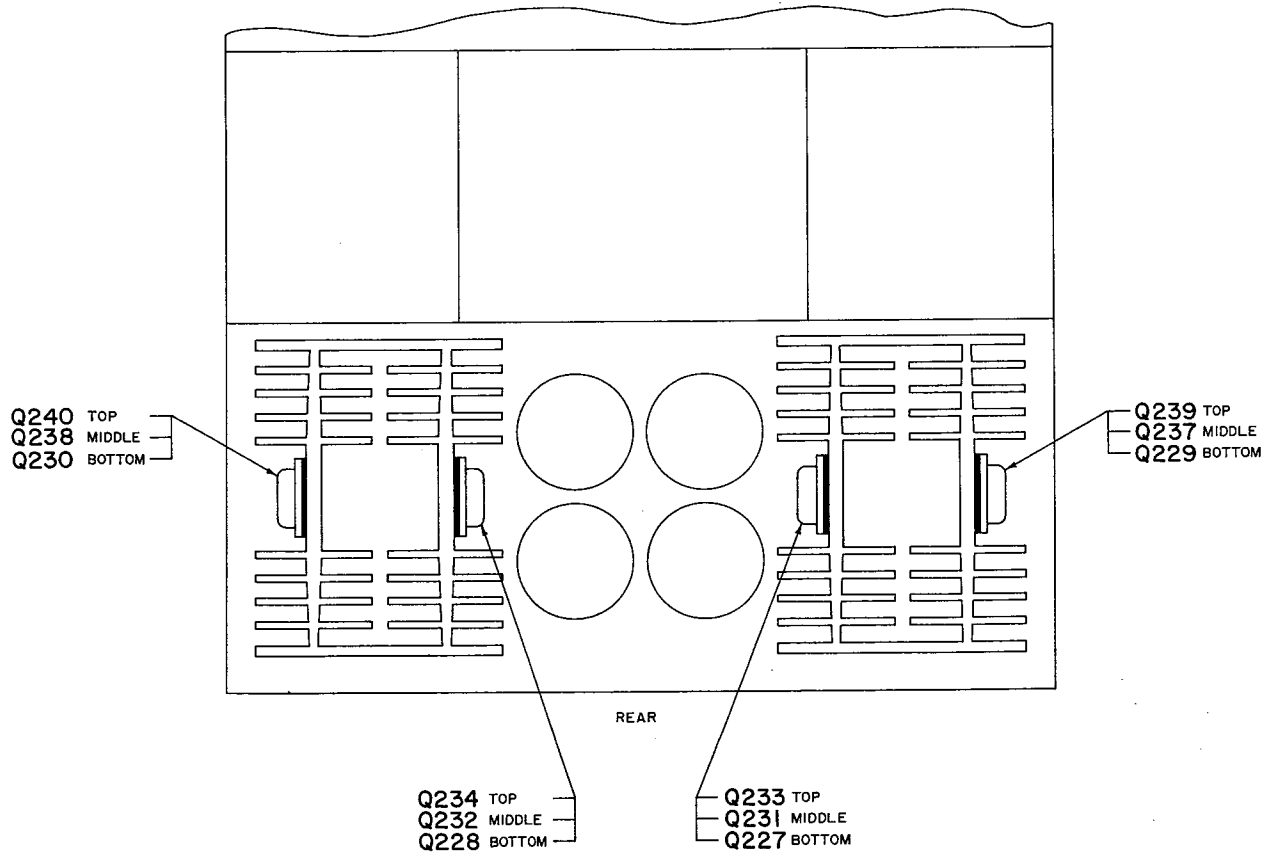

LOCATION OF TRANSISTORS NOT ON PC BOARD

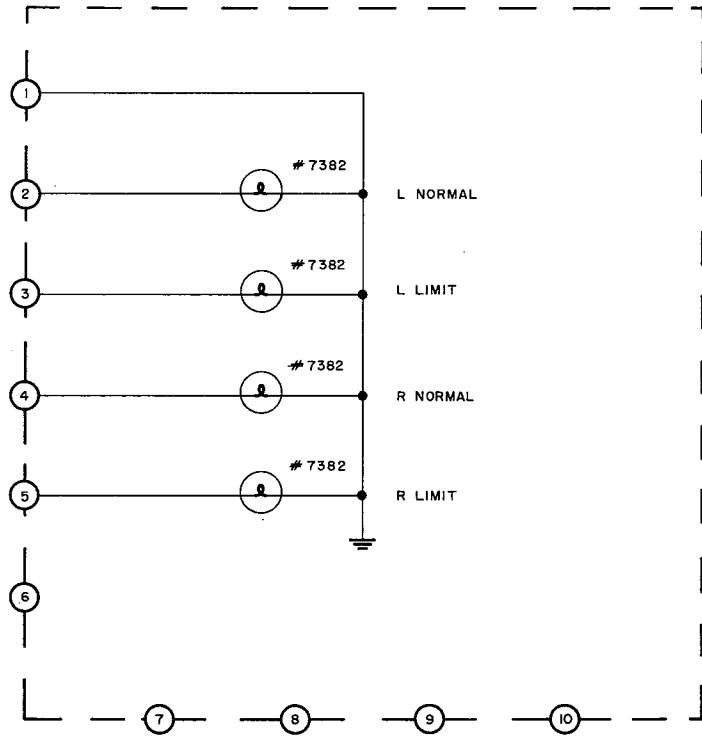

LIMIT LAMP PC BOARD 044-965

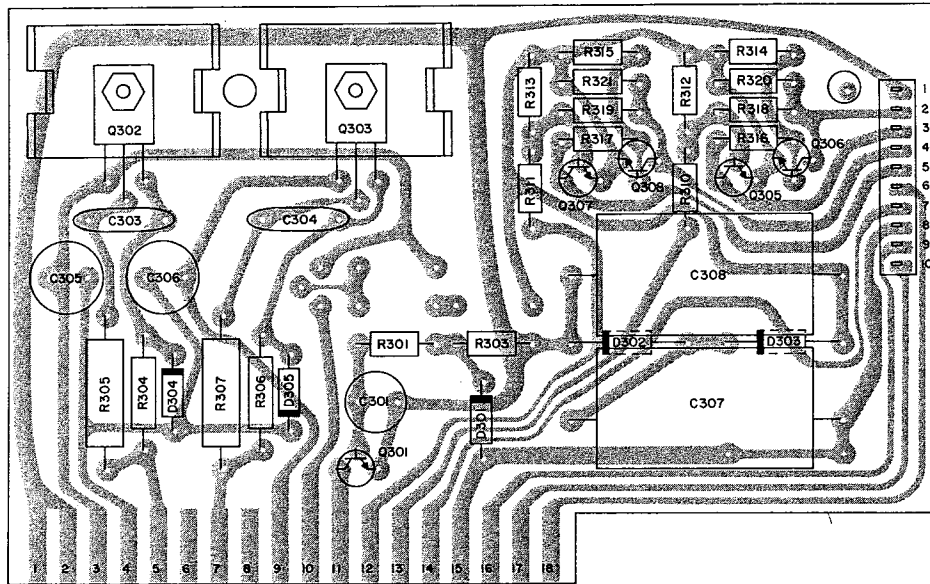

POWER SUPPLY PC BOARD O44-964

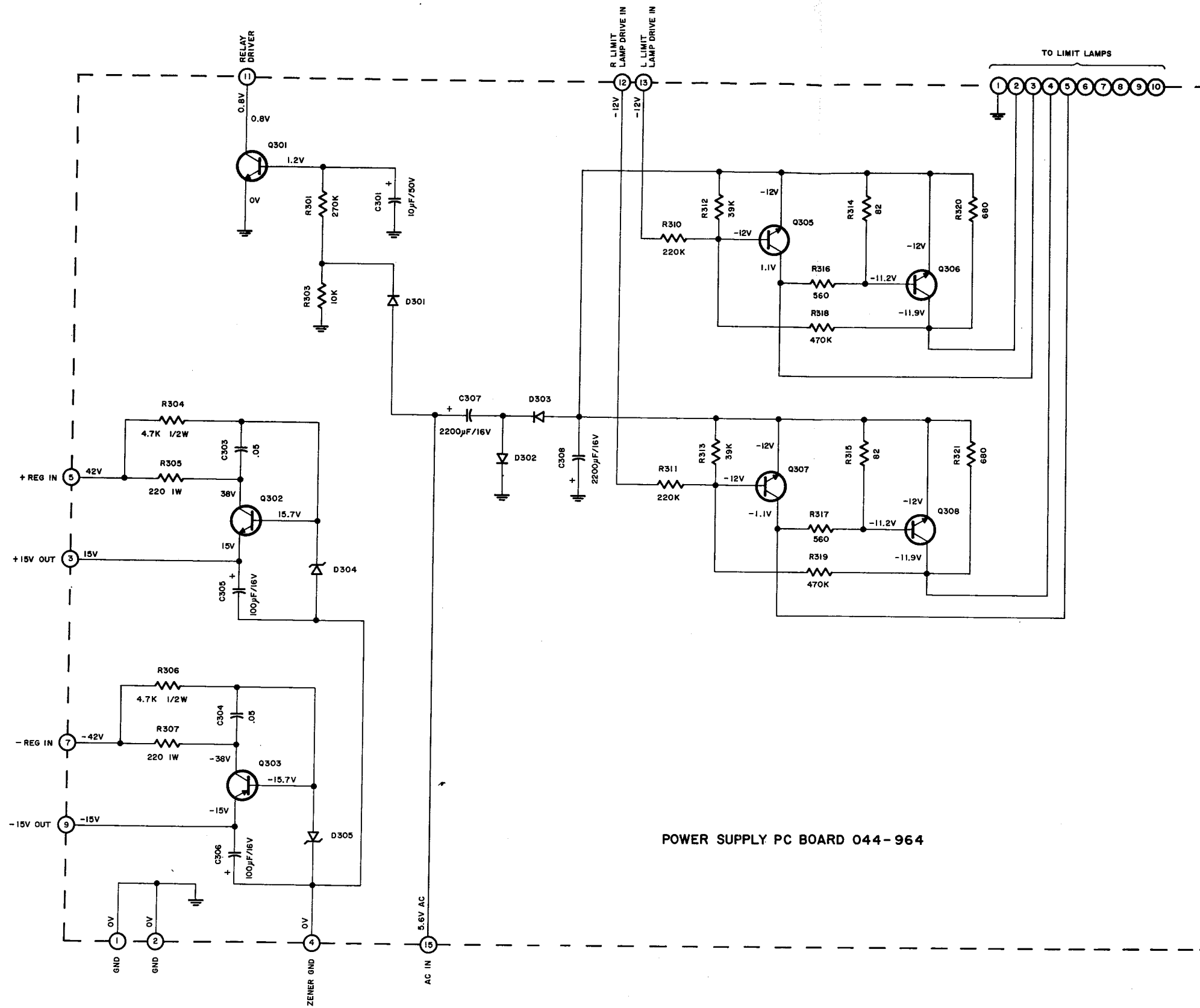

POWER SUPPLY PC BOARD O44-964

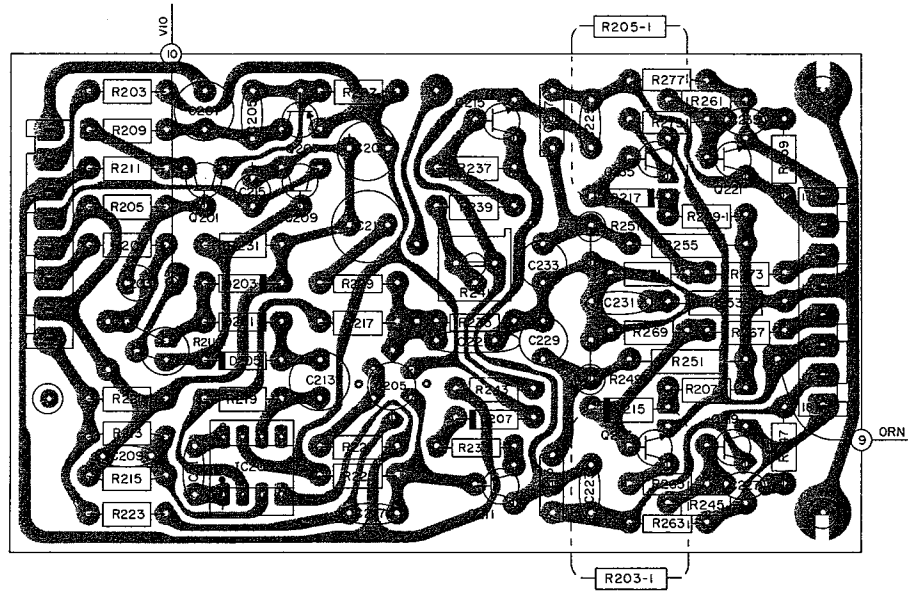

LEFT CHANNEL POWER OUTPUT PC BOARD O44-626

RIGHT CHANNEL
POWER OUTPUT PC BOARD 044-626

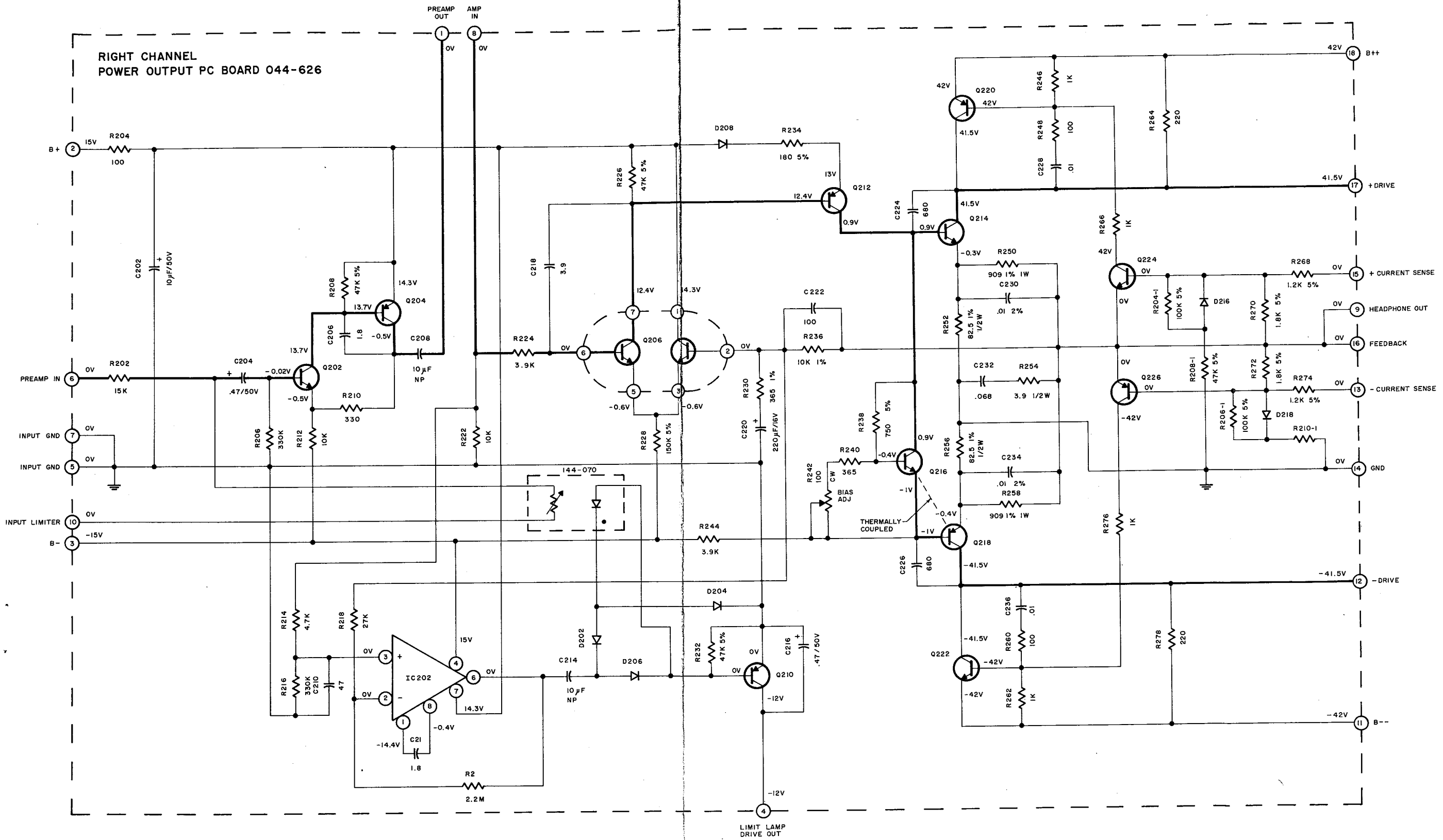

REPLACEMENT PARTS

All parts not listed are common items obtainable from radio parts jobbers.

Replacement parts may be obtained when ordered by PART NUMBER from:

McIntosh Laboratory, Inc.
Customer Service Department
2 Chambers Street
Binghamton, New York 13903
(telephone 607-723-3512)

CAPACITORS

Symbol Number	Description	Part Number
C201,202	Elect 10 μ F 50V	066-221
C203,204	Elect .47 μ F 50V	066-244
C207,208	Elect 10 μ F 35V	066-173
C213,214	Elect 10 μ F 35V	066-173
C215,216	Elect .47 μ F 50V	066-244
C219,220	Elect 220 μ F 16V	066-218
C227,228	Mylar .0047 μ F 100V	064-132
C229,230	Poly .01 μ F 2.5% 63%	064-142
C231,232	Mylar .068 μ F 100V	064-136
C233,234	Poly .01 μ F 2.5% 63%	064-142
C235,236	Mylar .0047 μ F 100V	064-132
C239,240	Elect 1 μ F 63V	066-248
C301	Elect 10 μ F 50V	066-221
C305,306	Elect 100 μ F 16V	066-203
C307,308	Elect 2200 μ F 16V	066-247
C309	Mylar .22 μ F 630V	064-052
C310,311	Elect 10000 μ F 50V	066-249
C312,313	Elect 10000 μ F 50V	066-249

DIODES

D201,202	Si. signal diode	070-047
D203,204	Si. signal diode	070-047
D205,206	Si. signal diode	070-047
D207,208	Si. signal diode	070-047
D209,210	Si. rectifier	070-031
D211,212	Si. rectifier	070-031
D213,214	Si. rectifier	070-031
D215,216	Zener diode	070-091
D217,218	Zener diode	070-091
D301	Si. signal diode	070-047
D302,303	Si. signal diode	070-031
D304,305	Zener diode 16V	070-089
D306	Zener diode 16V	070-089
D307	Rectifier bridge	070-050
D308	Si. rectifier	070-031

FUSES

F301	Fuse 8A	089-008
------	---------	---------

TRANSISTORS

Q201,202	Si. NPN transistor	132-093
Q203,204	Si. PNP transistor	132-096
Q205,206	Dual NPN transistor	132-155
Q209,210	Si. PNP transistor	132-096
Q211,212	Si. PNP transistor	132-096
Q213,214	Si. NPN transistor	132-149
Q215,216	Si. NPN transistor	132-093
Q217,218	Si. PNP transistor	132-148
Q219,220	Si. PNP transistor	132-150
Q221,222	Si. NPN transistor	132-143
Q223,224	Si. NPN transistor	132-136
Q225,226	Si. PNP transistor	132-147
Q227,228	Si. PNP transistor	132-151
Q229,230	Si. NPN transistor	132-152
Q231,232	Si. NPN transistor	132-164
Q233,234	Si. NPN transistor	132-164
Q237,238	Si. PNP transistor	132-165
Q239,240	Si. PNP transistor	132-165
Q301	Si. NPN transistor	132-090
Q302	Si. NPN transistor	132-078
Q303	Power transistor	132-079
Q304	Si. PNP transistor	132-096
Q305	Si. NPN transistor	132-090
Q306	Si. NPN transistor	132-143
Q307	Si. NPN transistor	132-090
Q308	Si. NPN transistor	132-143

INTEGRATED CIRCUITS

IC201,202	Integrated circuit	133-037
-----------	--------------------	---------

POTENTIOMETERS

R105,106	dB Adjust	134-294
R125,126	Log Adjust	134-293
R241,242	Bias Adjust	134-292
R201-1,202-1	Gain controls	134-273

RESISTORS

R229,230	Film 365 Ω 1% 1/4W	144-071
R235,236	Film 10k 1% 1/4W	144-053
R249,250	Film 909 Ω 1% 1/4W	144-073
R251,252	Film 82.5 Ω 1% 1/4W	144-072

R255,256	Film 82.5 Ω 1% 1/4W	144-072
R257,258	Film 909 Ω 1% 1/4W	144-073
R279,280	Thermistor	144-074
R281,282	Wirewound .15 Ω 5W	139-105
R283,284	Wirewound .15 Ω 5W	139-105
R287,288	Wirewound .15 Ω 5W	139-105
R289,290	Wirewound .15 Ω 5W	139-105
R295,296	Thermistor	144-074
R297,298	Film 61.9K 2% 1/4W	144-077
R299	Film 38.3K 2% 1/4W	144-076
R323	Thermistor	144-012
R324	Thermistor	144-012
R200-1	Film 38.3K 2% 1/4W	144-076
R203-1,204-1	Wirewound 220 Ω 2W	139-076

SWITCHES

S301	Power On Off	146-184
S302,303	Thermal cutout	153-017

RELAY

K301	Speaker control	087-018
------	-----------------	---------

TRANSFORMERS

T201,202	Output transformer	044-864
T301	Power transformer	044-853

FRONT PANEL & TRIM

Front panel	045-022
Knobs (all controls)	090-157

LAMPS

#7382 Normal & limit	058-061
----------------------	---------

MISCELLANEOUS ITEMS

Plastic feet	017-218
Shipping carton	045-921
Owners manual	038-921
Line Cord	170-021
Fuse holder	178-001
Audio cable	170-015

