

MC252

POWER AMPLIFIER

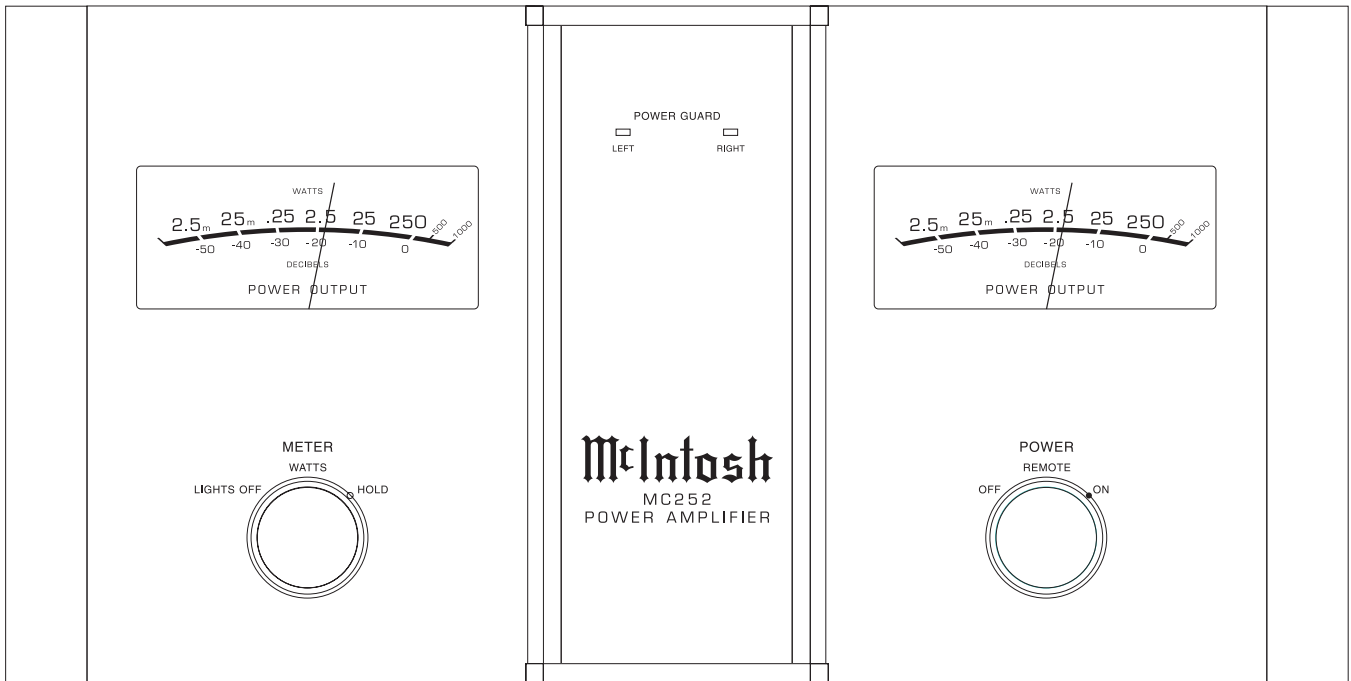

CONTENTS

Performance Specifications	2	Power Supply Schematic and PCB	15 - 16
Notes	2	Input Schematic and PCB	17 - 18
Rear Panel	3	Meter/Lighting Schematic and PCB	19 - 21
Section Location	4	Meter Led Schematic and PCB	21 - 22
Block Diagram	5 - 6	Parts List	23 - 26
Interconnection Diagram	7 - 8	Exploded View and Parts List	27 - 32
Heatsink Schematic and PCB	9 - 14	Repacking Instructions	33

SERVICE MANUAL

PERFORMANCE SPECIFICATIONS

Power Output Stereo

250 watts into a 2, 4 or 8 ohm load is the minimum sine wave continuous average power per channel with both channels operating

Power Output Mono Bridged

500 watts into a 4, 8 or 16 ohm load is the minimum sine wave continuous average power output

Power Output Mono Bi-Amp

500 watts into a 1, 2 or 4 ohm load is the minimum sine wave continuous average power output

Output Load Impedance

Stereo: 2, 4 or 8 ohms

Mono: 1, 2, 4, 8, or 16 ohms

Rated Power Band

20Hz to 20,000Hz

Total Harmonic Distortion

Maximum Total Harmonic Distortion at any power level from 250 milliwatts to rated power output is 0.005%

Intermodulation Distortion

Maximum Intermodulation Distortion if instantaneous peak output per channel does not exceed twice the rated output, for any combination of frequencies from 20Hz to 20,000Hz, with all channels operating is 0.005%

Dynamic Headroom

2.0dB

Frequency Response

+0, -0.25dB from 20Hz to 20,000Hz

+0, -3dB from 10Hz to 100,000Hz

Sensitivity

1.6 Volts Unbalanced Input

3.2 Volts Balanced Input

A-Weighted Signal To Noise Ratio

112dB below rated output

Input Impedance

10,000 ohms

Wide Band Damping Factor

Greater than 40

Power Requirements

100 Volts, 50/60Hz at 8 amps

110 Volts, 50/60Hz at 7.2 amps

120 Volts, 50/60Hz at 6.6 amps

220 Volts, 50/60Hz at 3.3 amps

230 Volts, 50/60Hz at 3.3 amps

240 Volts, 50/60Hz at 3.3 amps

Note: Refer to the rear panel of the MC252 for the correct voltage.

Overall Dimensions

17-1/2 inches (44.45cm) W, 9-7/16 inches (23.97cm) H,

14-3/4 inches (37.5cm) D, including clearance for connectors

Weight

94.5 pounds (207.9kg) net, 108.5 pounds (238.7kg) in shipping carton

NOTES

1. The heavy notes on the schematic denote the primary signal path.
2. Unless otherwise noted, all voltages indicated on the schematics are measured under the following conditions:
 - a. AC input at 120 volts, 50/60Hz.
 - b. All voltages are +/-10% with respect to ground. A high impedance (10 megaohm) voltmeter must be used.
3. Unless otherwise specified:
 - a. Resistor values are in ohms.
 - b. Capacitor values are microfarads (uF).
 - c. Inductor values are in microhenries (uH).
4. On PC board drawings, Square pad indicates:
 - a. Polarized Capacitors - Positive
 - b. Diodes - Cathode
 - c. Others - Pin 1
5. **WARNING**
Parts marked with the symbol  have critical characteristics. Use only replacement parts recommended by the manufacturer.

TOP AND REAR PANEL

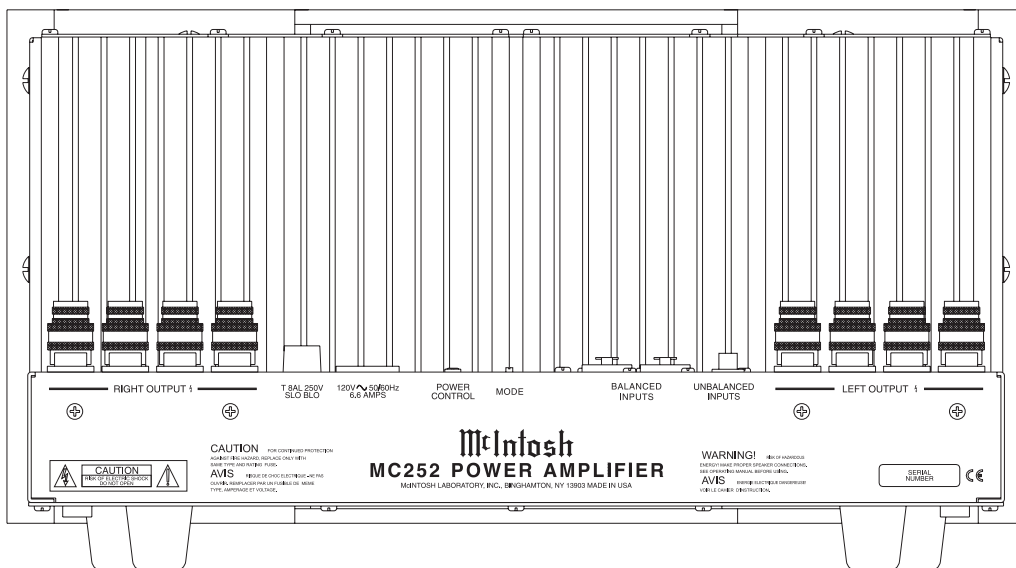
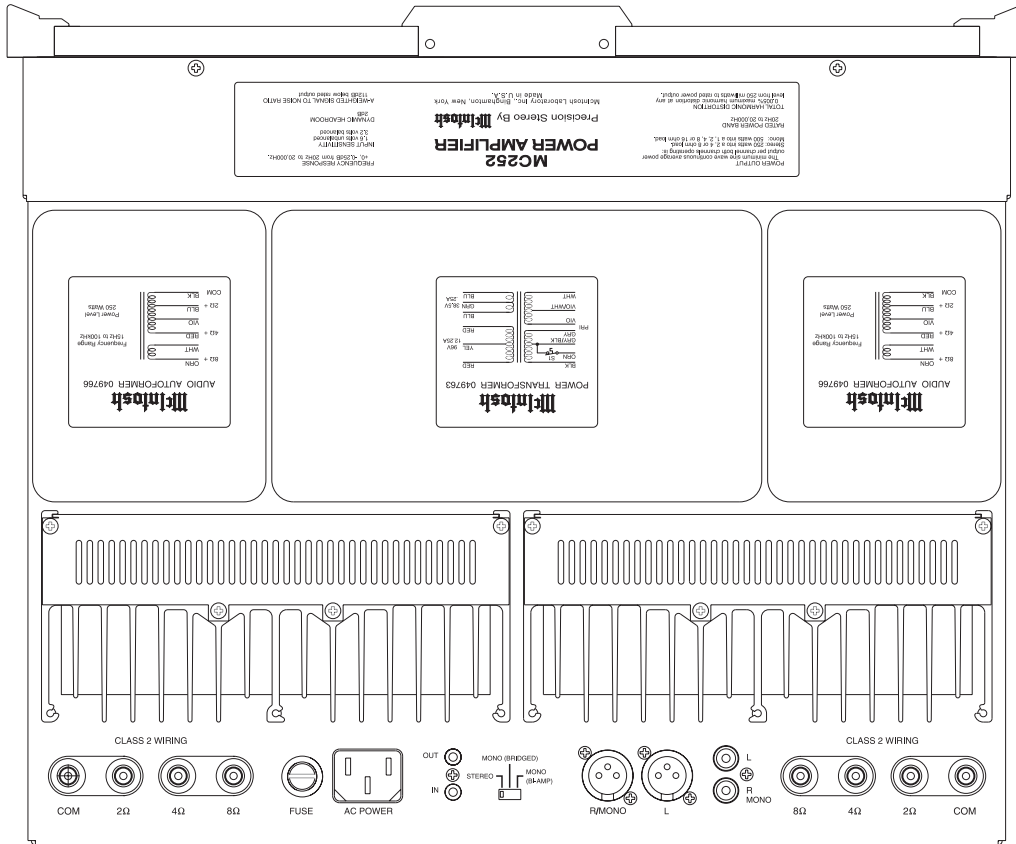

SECTION LOCATIONS

TOP VIEW WITH COVER REMOVED

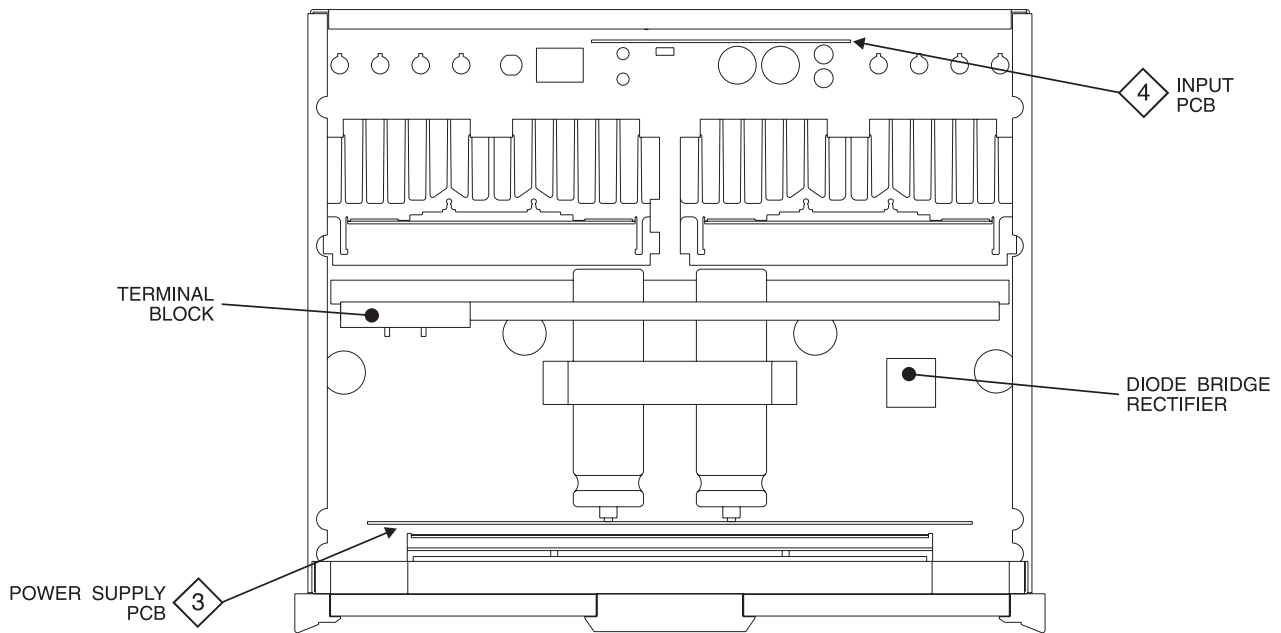
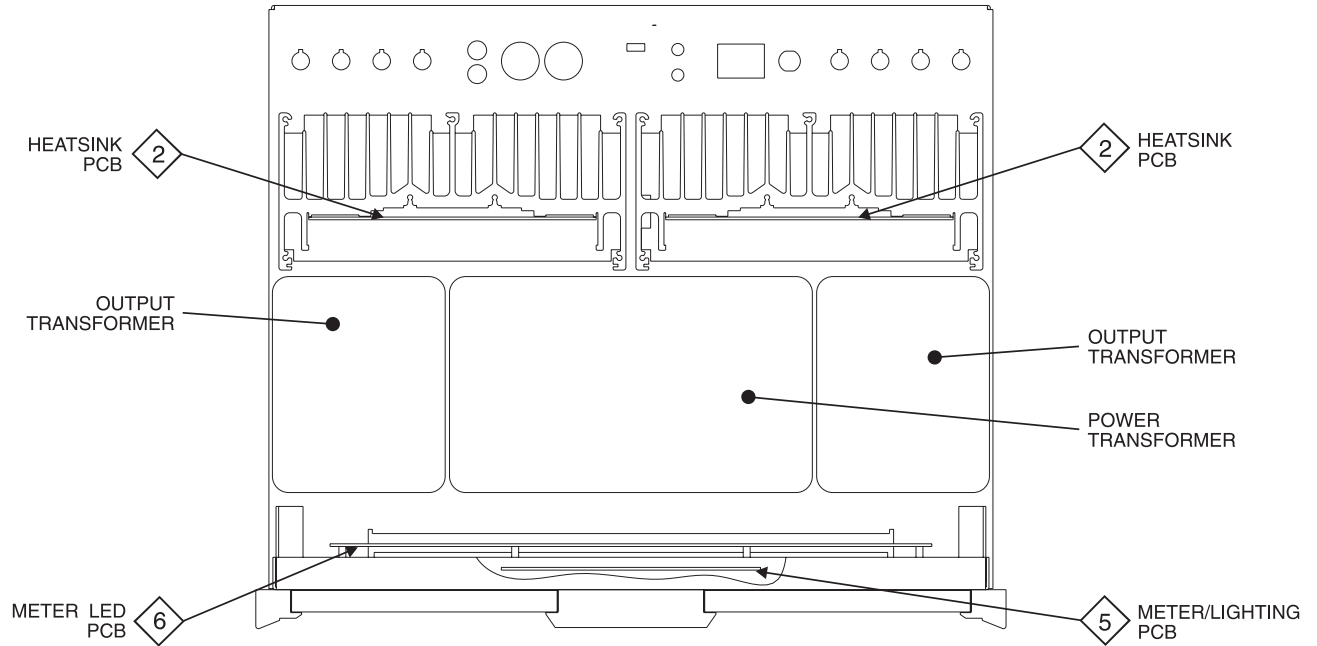

BOTTOM VIEW WITH COVER REMOVED

BLOCK DIAGRAM

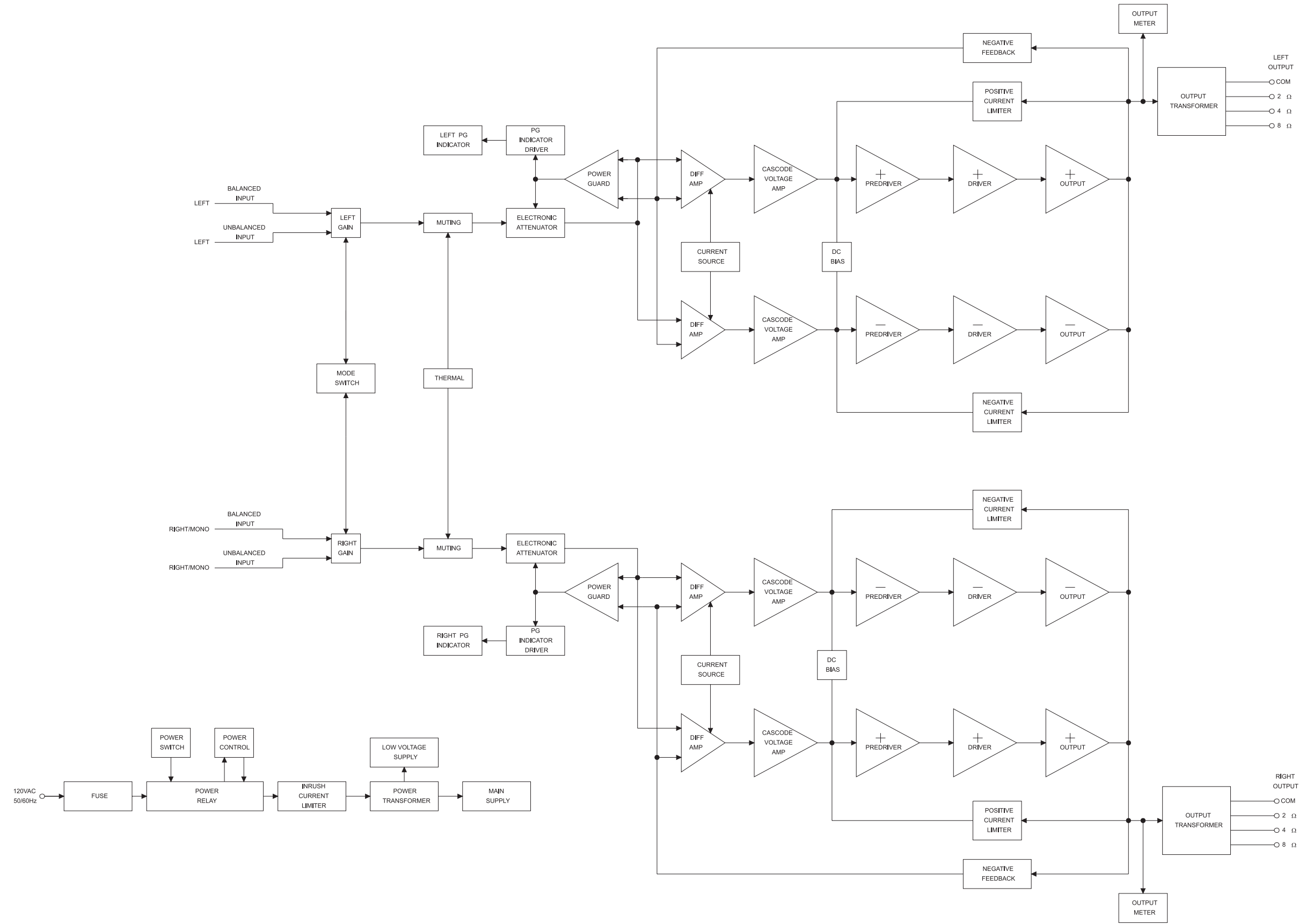

1 INTERCONNECT

! WARNING Parts located in the shaded area have critical characteristics. Use only replacement parts recommended by the manufacturer.

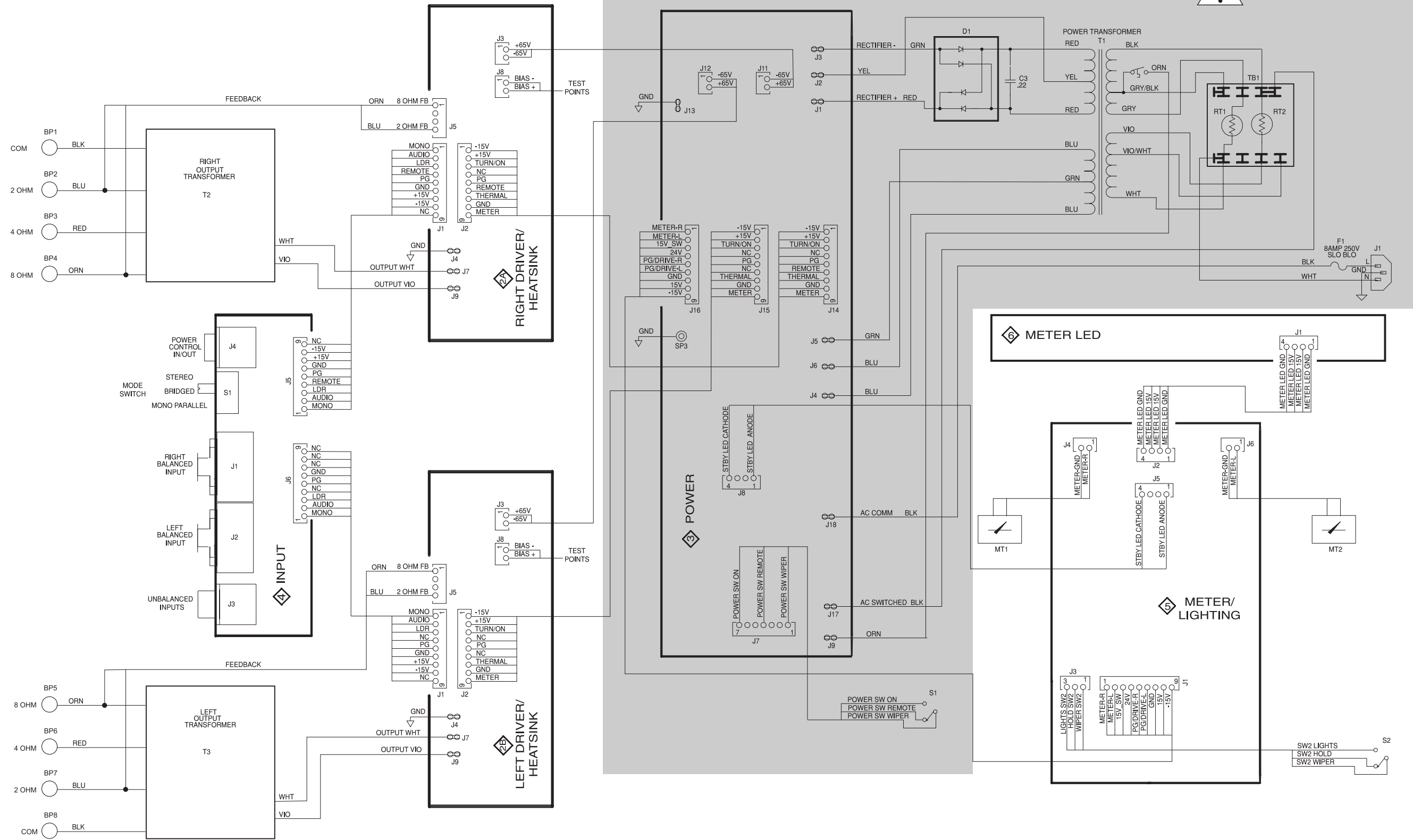

2A 2B

HEATSINK 049986 DRIVER SECTION

MC252

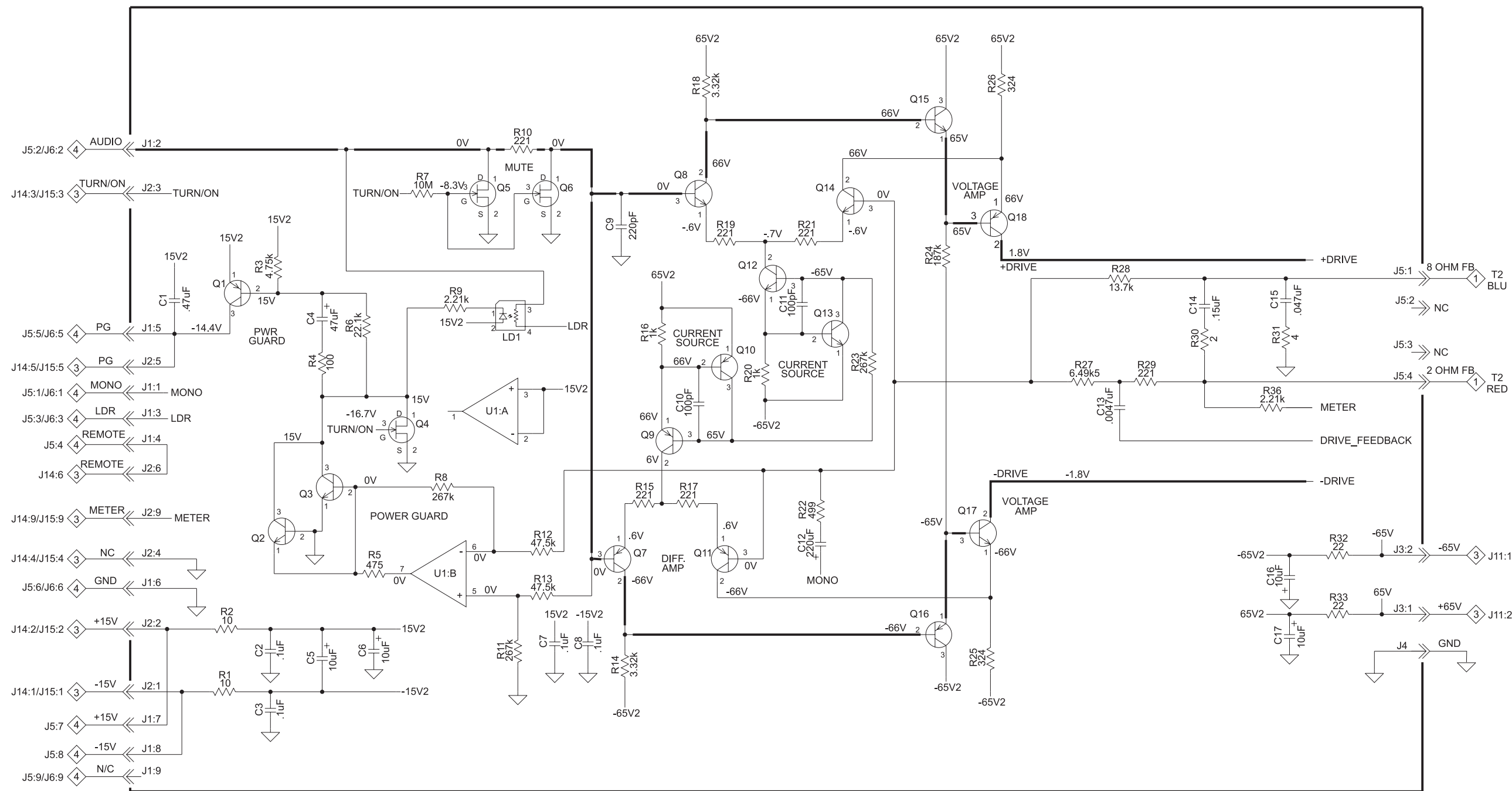

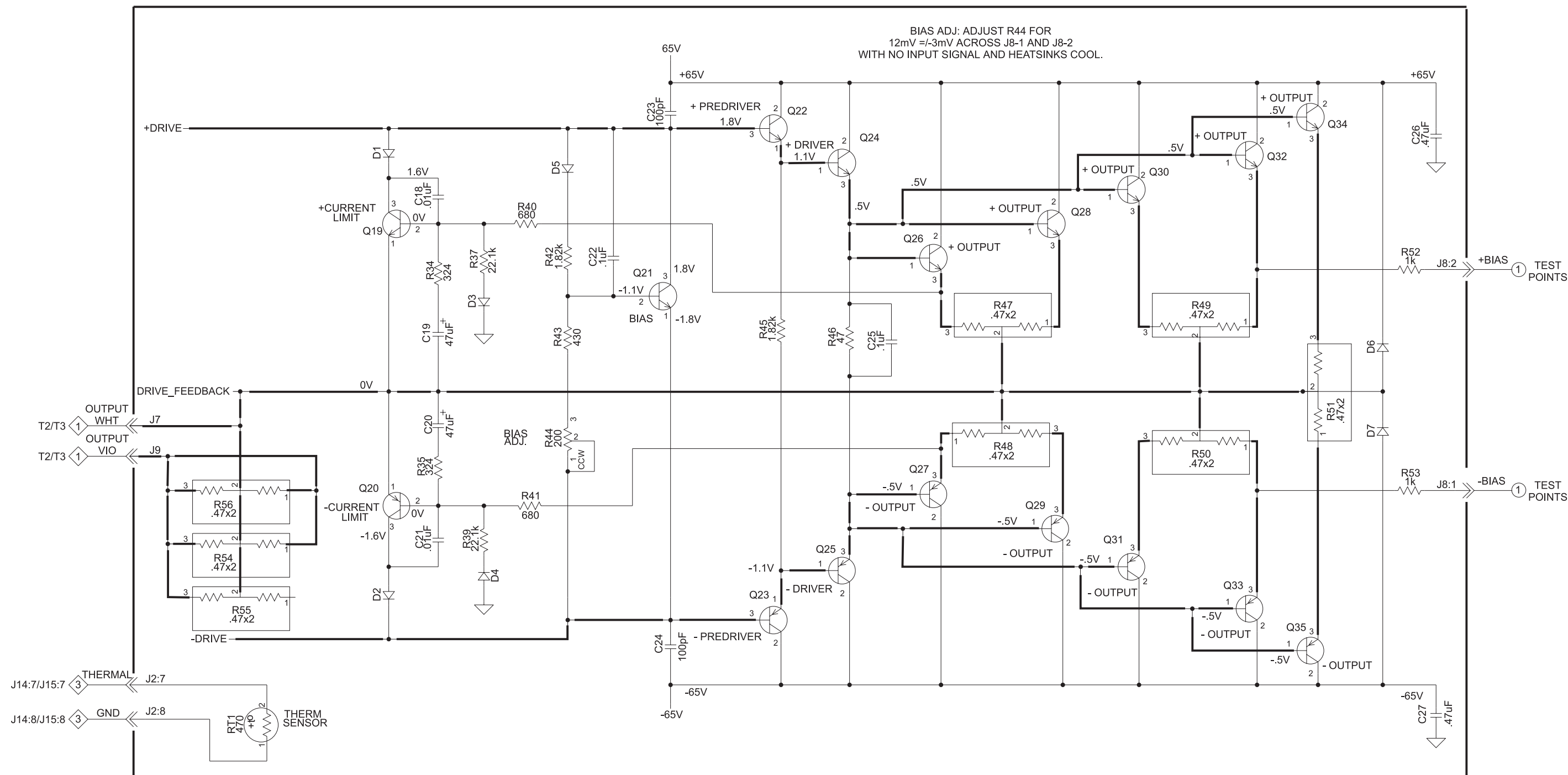

2A 2B

HEATSINK 049986

MC252

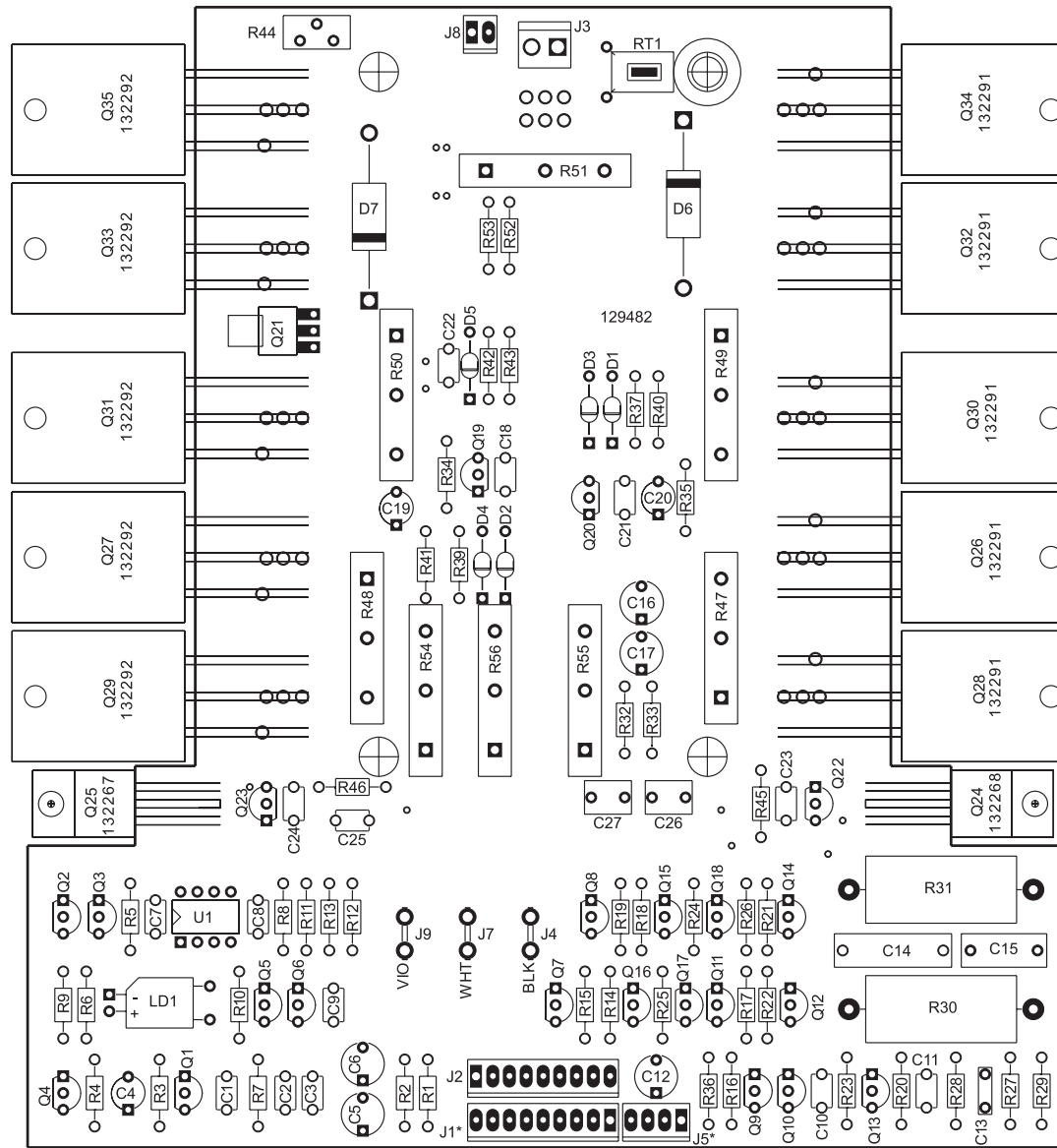

POWER SUPPLY 049757

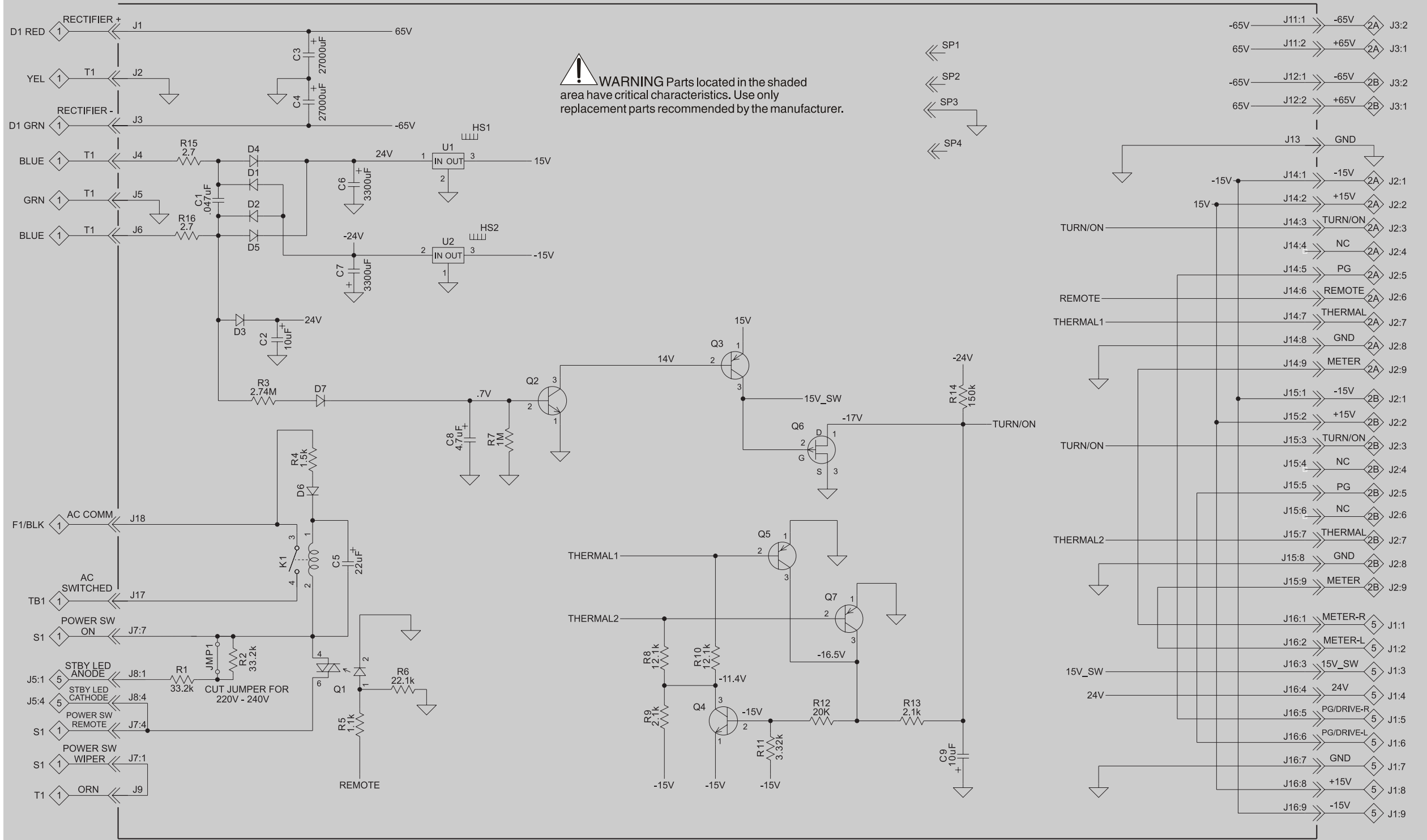

WARNING Parts located in the shaded area have critical characteristics. Use only replacement parts recommended by the manufacturer.

SP1
SP2
SP3
SP4

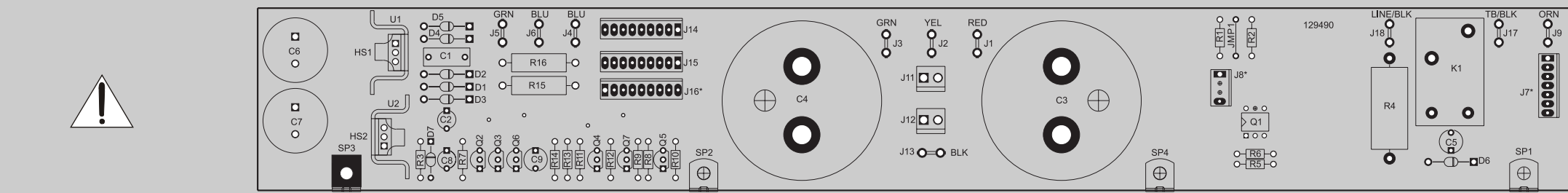
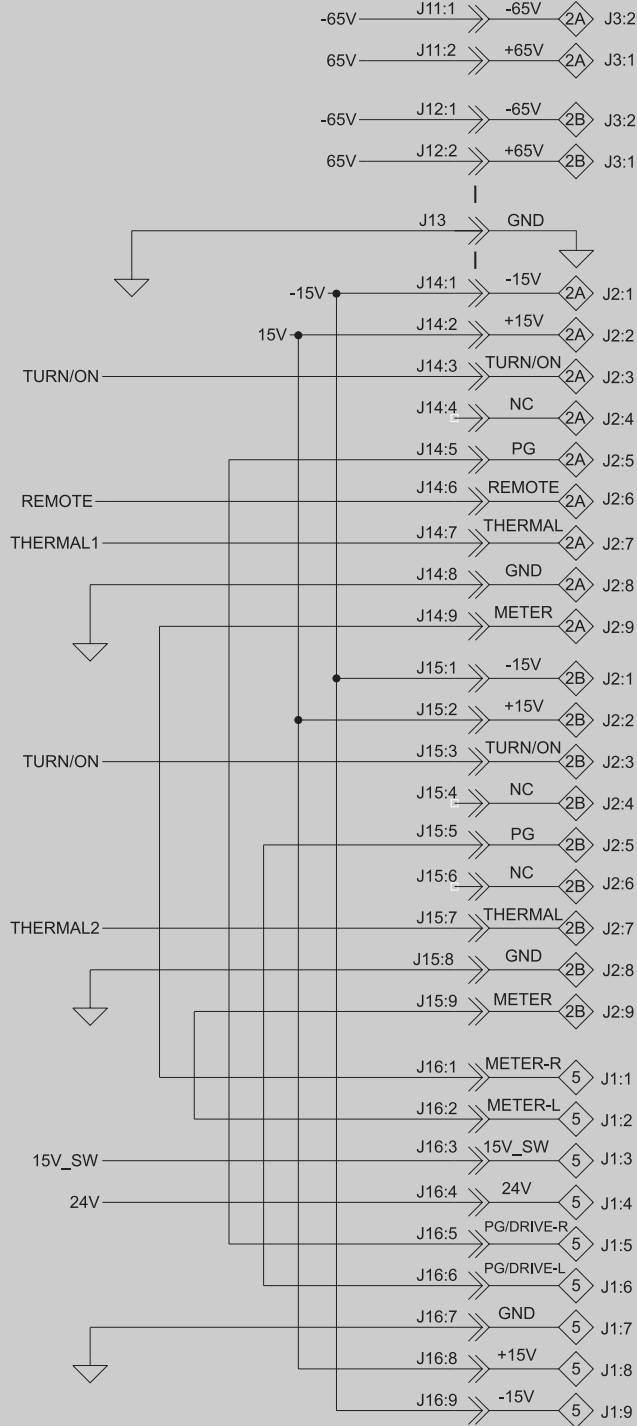

* DENOTES COMPONENTS ON FARSIDE OF PC BOARD

4 INPUT 049755

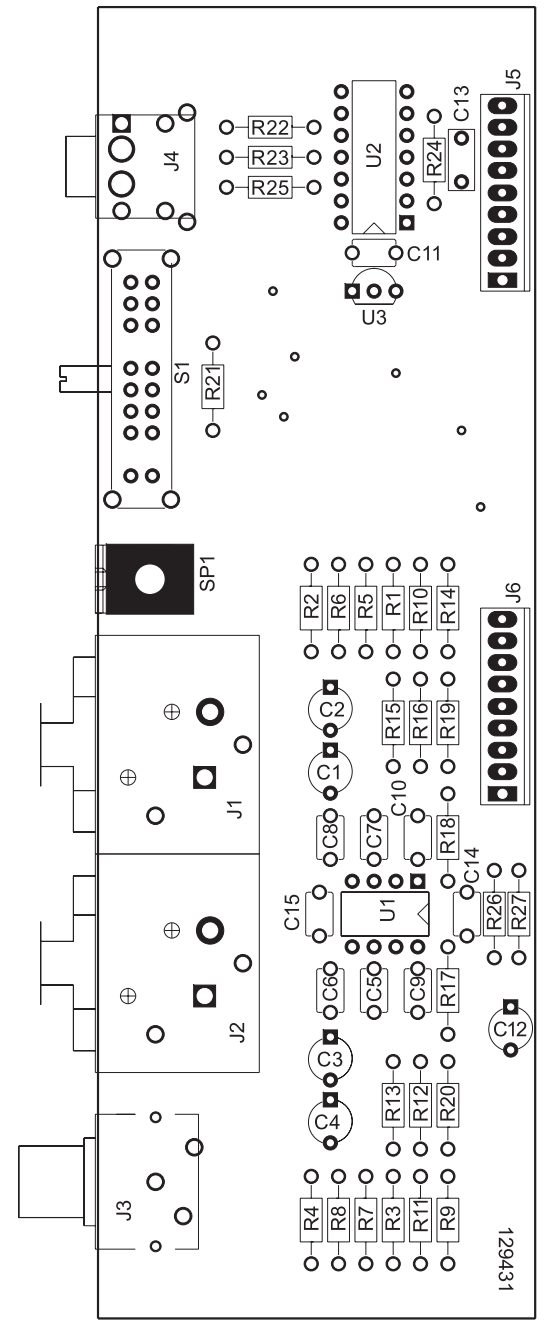
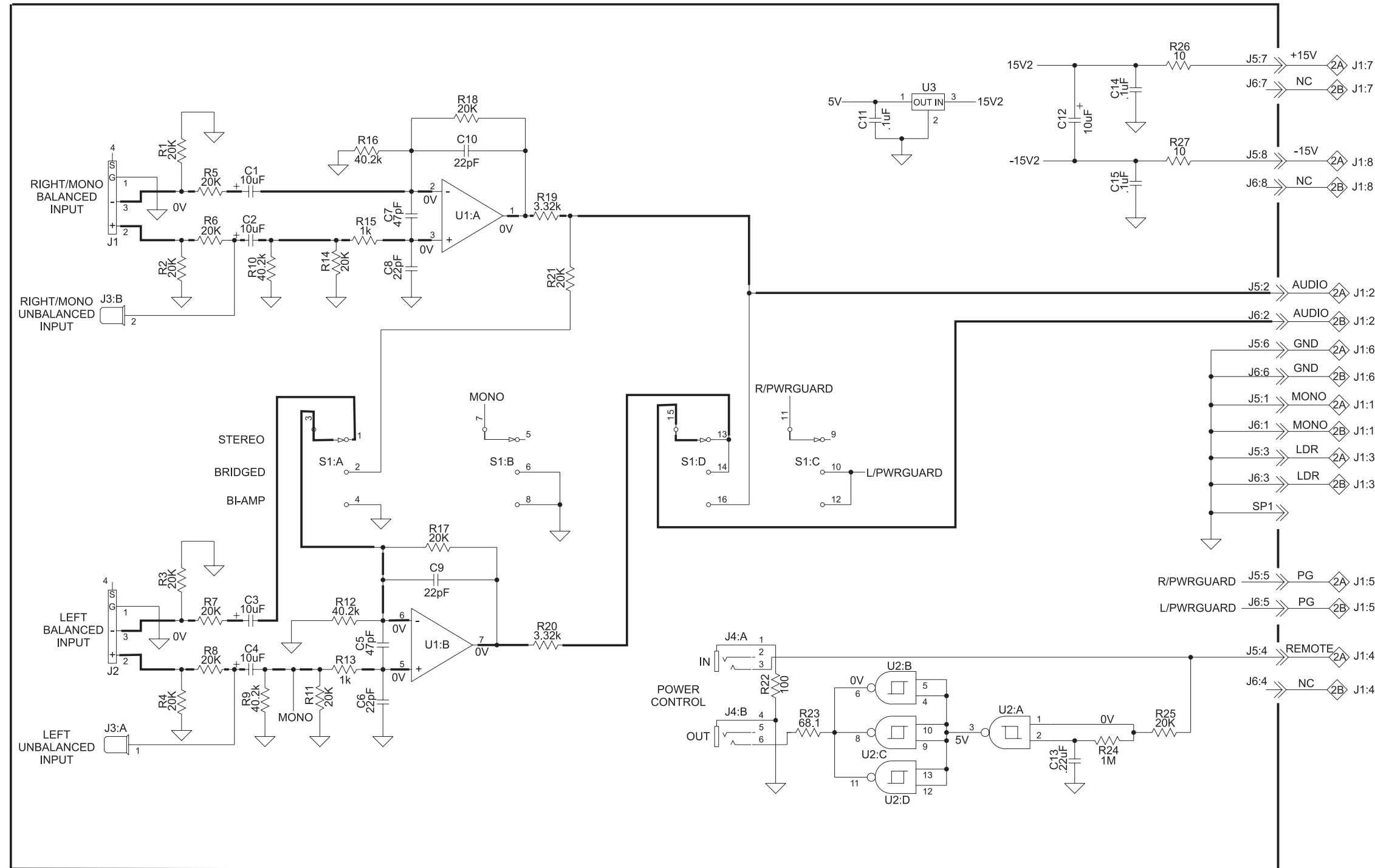

5 METER/LIGHTING 049756

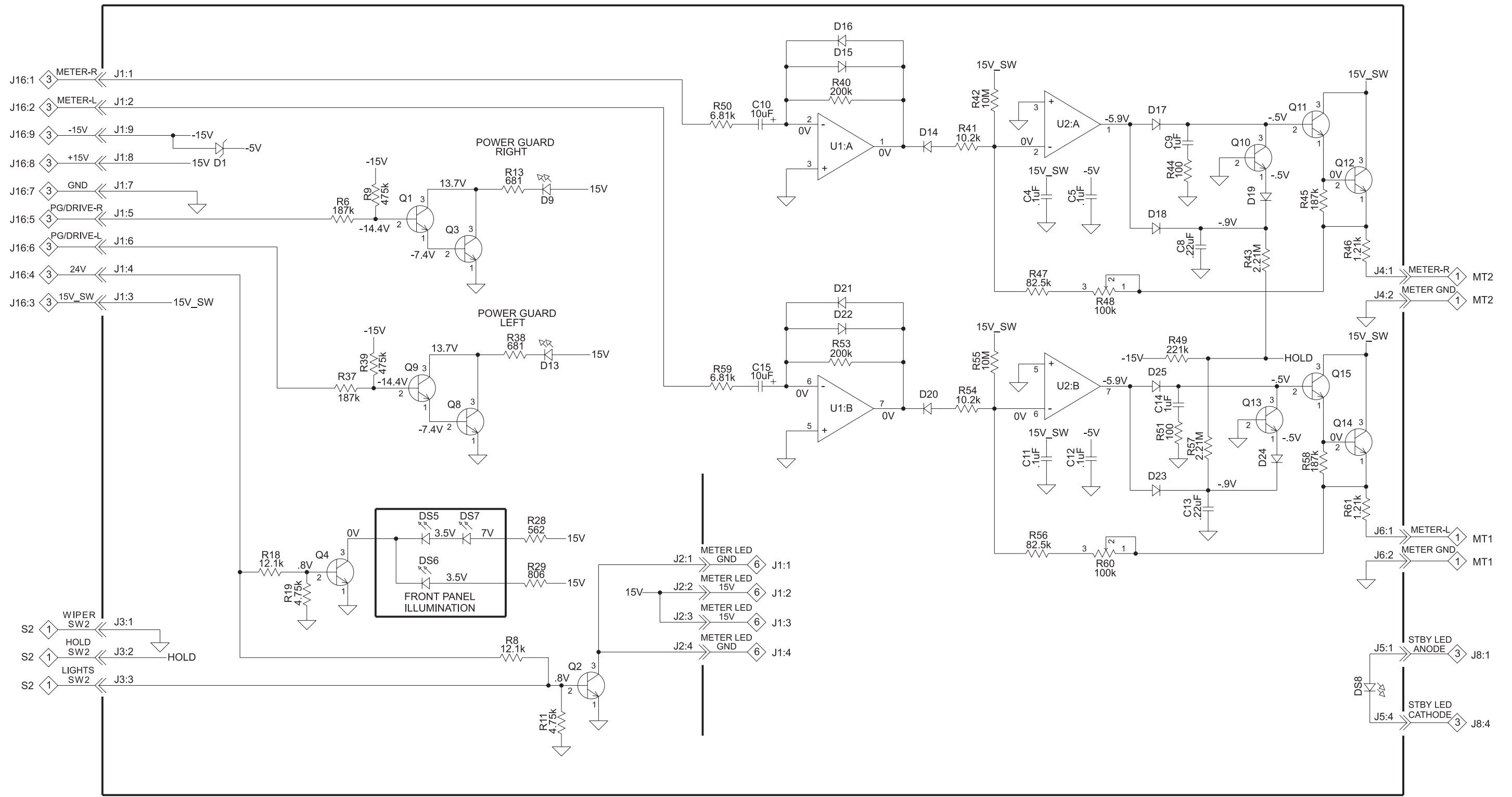

5 METER/LIGHTING 049756

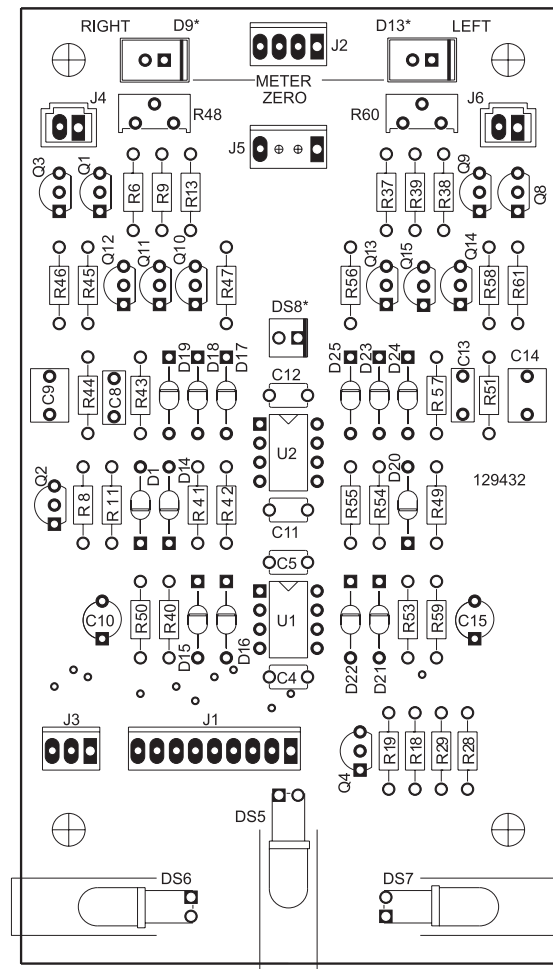

* DENOTES COMPONENTS ON FARSIDE OF PCB

6 METER LED 049758

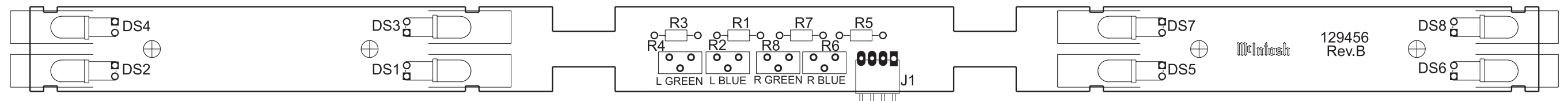
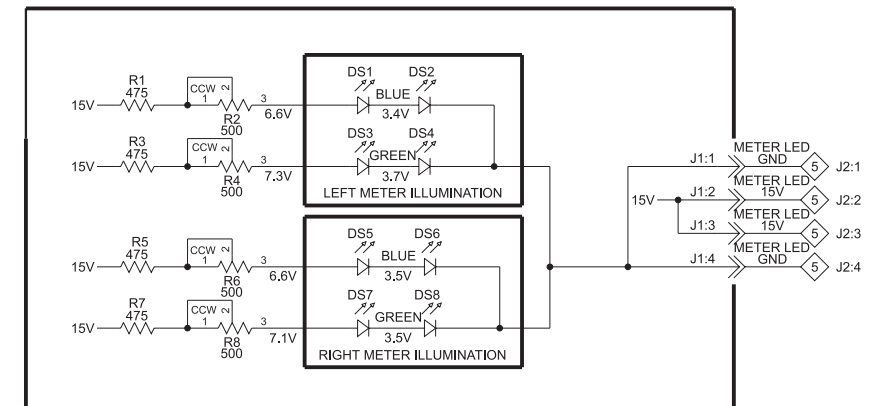

PARTS LIST

Ref. No. Description Part No.



INTERCONNECT

BP1	Binding Post BLK	117741
BP2	Binding Post RED	117741
BP3	Binding Post RED	117741
BP4	Binding Post RED	117741
BP5	Binding Post RED	117741
BP6	Binding Post RED	117741
BP7	Binding Post RED	117741
BP8	Binding Post BLK	117741
D1	Diode Bridge Rectifier	070139
F1	Fuse	089105
J1	Receptacle, AC Line	117487
MT1	Meter	124084
MT2	Meter	124084
RT1	Thermistor Assembly	052008
RT2	Thermistor Assembly	052008
S1	Switch	146243
S2	Switch	146243
T1	Power Transformer	049763
T2	Output Transformer	049766
T3	Output Transformer	049766
TB1	Terminal Block AC	074091



049986 HEATSINK

C1	CAP DISC MONO .47UF 50V	061249
C2	CAP MONO .1uF 50V 20% Z5U	061305
C3	CAP MONO .1uF 50V 20% Z5U	061305
C4	CAP ELECT 47UF 35V	066446
C5	CAP ELECT 10UF 100VDC	066462
C6	CAP ELECT 10UF 100VDC	066462
C7	CAP MONO .1uF 50V 20% Z5U	061305
C8	CAP MONO .1uF 50V 20% Z5U	061305
C9	CAP MONO 220PF 100V 10PO	061301
C10	CAP MONO 100PF 100V 10% NPO	061300
C11	CAP MONO 100PF 100V 10% NPO	061300
C12	CAP ELECT 220UF 25V	066507
C13	CAP MPF 0.0047UF 5VDC	064308
C14	CAP POLYPROP 0.15UF 10VDC	064363
C15	CAP POLYPROP .047UF 10VDC	064364
C16	CAP ELECT 10UF 100VDC	066462
C17	CAP ELECT 10UF 100VDC	066462
C18	CAP MONO .01UF 50V 20% X7R	061304
C19	CAP ELECT 47UF 35V	066446
C20	CAP ELECT 47UF 35V	066446
C21	CAP MONO .01UF 50V 20% X7R	061304
C22	CAP MONO .1uF 50V 20% Z5U	061305
C23	CAP MONO 100PF 100V 10PO	061300
C24	CAP MONO 100PF 100V 10% NPO	061300
C25	CAP MONO .1uF 50V 20% Z5U	061305
C26	CAP MPF 0.47UF 5/100VDC	064442
C27	CAP MPF 0.47UF 5/100VDC	064442
D1	DIODE SILICON	070047
D2	DIODE SILICON	070047
D3	DIODE SILICON	070047
D4	DIODE SILICON	070047
D5	DIODE SILICON	070047
D6	DIODE 200V 3A	070126
D7	DIODE 200V 3A	070126
J1	CONN MALE 9 POS FRICTION LK	117244
J2	CONN MALE 9 POS FRICTION LK	117244
J3	CONN HEADER 2 PIN 0.156	117404
J4	BLADE FASTON W/FEET	117708
J5	CONN 4 PIN	117215
J7	BLADE FASTON W/FEET	117708

J8	CONN 2 PIN MALE	117213
J9	BLADE FASTON W/FEET	117708
LD1	LDR NETWORK VTL5C9	144179
Q1	TRANSISTOR PNP	132224
Q2	TRANSISTOR NPN	132223
Q3	TRANSISTOR NPN	132223
Q4	TRANSISTOR N JFET	132222
Q5	TRANSISTOR N JFET	132222
Q6	TRANSISTOR N JFET	132222
Q7	TRANSISTOR NPN POWER	132255
Q8	TRANSISTOR SI NPN 25V	132254
Q9	TRANSISTOR NPN POWER	132255
Q10	TRANSISTOR PNP	132224
Q11	TRANSISTOR NPN POWER	132255
Q12	TRANSISTOR SI NPN 25V	132254
Q13	TRANSISTOR NPN	132223
Q14	TRANSISTOR SI NPN 25V	132254
Q15	TRANSISTOR NPN	132223
Q16	TRANSISTOR PNP	132224
Q17	TRANSISTOR NPN 25C3334C	132285
Q18	TRANSISTOR PNP 2SA32IC	132286
Q19	TRANSISTOR NPN SILICON	132171
Q20	TRANSISTOR PNP SILICON	132172
Q21	TRANSISTOR NPN	132223
Q22	TRANSISTOR NPN 25C3334C	132285
Q23	TRANSISTOR PNP 2SA32IC	132286
Q24	TRANSISTOR NPN	132268
Q25	TRANSISTOR PNP	132267
Q26	TRANSISTOR NPN POW 2SC5200	132291
Q27	TRANSISTOR PNP POW 2SA1943	132292
Q28	TRANSISTOR NPN POW 2SC5200	132291
Q29	TRANSISTOR PNP POW 2SA1943	132292
Q30	TRANSISTOR NPN POW 2SC5200	132291
Q31	TRANSISTOR PNP POW 2SA1943	132292
Q32	TRANSISTOR NPN POW 2SC5200	132291
Q33	TRANSISTOR PNP POW 2SA1943	132292
Q34	TRANSISTOR NPN POW 2SC5200	132291
Q35	TRANSISTOR PNP POW 2SA1943	132292
R1	RES MF 10 OHM 1% 1/4W	144157
R2	RES MF 10 OHM 1/4W	144157
R3	RES MF 4.75K 1% 1/4W	144097
R4	RES MF 100 OHM 1% 1/4W	144196
R5	RES MF 475 OHM 1% 1/4W	144086
R6	RES MF 22.1K 1% 1/4W	144187
R7	RES MF 10M 1% 1/4W	144264
R8	RES MF 267K 1% 1/4W	144118
R9	RES MF 2.21K 1% 1/4W	144298
R10	RES MF 221 OHM 1% 1/4W	144172
R11	RES MF 267K 1% 1/4W	144118
R12	RES MF 47.5K 1% 1/4W	144108
R13	RES MF 47.5K 1/4W	144108
R14	RES MF 3.32K 1% 1/4W	144095
R15	RES MF 221 OHM 1% 1/4W	144172
R16	RES MF 1K 1% 1/4W	144090
R17	RES MF 221 OHM 1% 1/4W	144172
R18	RES MF 3.32K 1/4W	144095
R19	RES MF 221 OHM 1% 1/4W	144172
R20	RES MF 1K 1% 1/4W	144090
R21	RES MF 221 OHM 1% 1/4W	144172
R22	RES MF 499 OHM 1% 1/4W	144087
R23	RES MF 267K 1% 1/4W	144118
R24	RES MF 187K 1% 1/4W	144406
R25	RES MF 324 OHM 1% 1/4W	144338
R26	RES MF 324 OHM 1% 1/4W	144338
R27	RES MF 6.49K .5% 1/4W	144401
R28	RES MF 13.7K 1% 1/4W	144342
R29	RES MF 221 OHM 1/4W	144172
R30	RES WW 2 OHM 10% 5W	139005

R31	RES WW 4 OHM 5W	139119
R32	RES FP 22 OHM 1/4W 5	137033
R33	RES FP 22 OHM 1/4W 5	137033
R34	RES MF 324 OHM 1/4W	144338
R35	RES MF 324 OHM 1/4W	144338
R36	RES MF 2.21K 1/4W	144298
R37	RES MF 22.1K 1/4W	144187
R39	RES MF 22.1K 1/4W	144187
R40	RES MET OX 680 OHM 5% .5W	137093
R41	RES MET OX 680 OHM 5% .5W	137093
R42	RES MF 1.82K 1% 1/4W	144296
R43	RES MET OX 430 OHM 5% .5W	137095
R44	POT TRIM 200 OHM 20% HORIZ AD	134390
R45	RES MF 1.82K 1% 1/4W	144296
R46	RES MET OX 47 OHM 5% .5W	137096
R47	RES WW DUAL .47 OHM 5% 5W	139199
R48	RES WW DUAL .47 OHM 5% 5W	139199
R49	RES WW DUAL .47 OHM 5% 5W	139199
R50	RES WW DUAL .47 OHM 5% 5W	139199
R51	RES WW DUAL .47 OHM 5W	139199
R52	RES MF 1K 1% 1/4W	144090
R53	RES MF 1K 1% 1/4W	144090
R54	RES WW DUAL .47 OHM 5W	139199
R55	RES WW DUAL .47 OHM 5% 5W	139199
R56	RES WW DUAL .47 OHM 5% 5W	139199
RT1	SENSOR THERMAL	144249
U1	IC OPAMP NE4558N	133028



049757 POWER SUPPLY

C1	CAP POLY .047UF 10% 250VDC	064364
C2	CAP ELECT 10UF 50V	066445
C3	27000uF 100V ELECTROLYTIC	066489
C4	27000uF 100V ELECTROLYTIC	066489
C5	CAP ELECT 22UF 100V	066506
C6	CAP ELECT 3300UF 35V	066509
C7	CAP ELECT 3300UF 35V	066509
C8	CAP ELECT 4.7UF 50V	066512
C9	CAP ELECT 10UF 100VDC	066462
D1	DIODE RECTIFIER	070131
D2	DIODE RECTIFIER	070131
D3	DIODE RECTIFIER	070131
D4	DIODE RECTIFIER	070131
D5	DIODE RECTIFIER	070131
D6	DIODE RECTIFIER	070131
D7	DIODE SILICON	070047
HS1	HEATSINK T0220	080014
HS2	HEATSINK T0220	080014
J1	BLADE FASTON W/FEET	117708
J2	BLADE FASTON W/FEET	117708
J3	BLADE FASTON W/FEET	117708
J4	BLADE FASTON W/FEET	117708
J5	BLADE FASTON W/FEET	117708
J6	BLADE FASTON W/FEET	117708
J7	CONN MALE 7 PIN	117217
J8	CONN 4 PIN	117215
J9	BLADE FASTON W/FEET	117708
J11	CONN HEADER 2 PIN 0.156	117404
J12	CONN HEADER 2 PIN 0.156	117404
J13	BLADE FASTON W/FEET	117708
J14	CONN MALE 9 POS FRICTION LK	117244
J15	CONN MALE 9 POS FRICTION LK	117244
J16	CONN MALE 9 POS FRICTION LK	117244
J17	BLADE FASTON W/FEET	117708
J18	BLADE FASTON W/FEET	117708
K1	RELAY 48V 18.8mA	87052
Q1	TRIAC DRIV OPTOCPLR 600V	131022
Q2	TRANSISTOR NPN	132223
Q3	TRANSISTOR PNP	132224

PARTS LIST con't

Q4	TRANSISTOR NPN	132223
Q5	TRANSISTOR PNP	132224
Q6	TRANSISTOR P CHAN JUNC FET	132226
Q7	TRANSISTOR PNP	132224
R1	RES MF 33.2K 1% 1/4W	144015
R2	RES MF 33.2K 1% 1/4W	144015
R3	RES MF 2.74M 1/4W	144271
R4	RES WW 1.5K 10% 5W	139079
R5	RES MF 1.1K 1% 1/4W	144091
R6	RES MF 22.1K 1% 1/4W	144187
R7	RES MF 1M 1/4W	144269
R8	RES MF 12.1K 1% 1/4W	144154
R9	RES MF 2.1K 1% 1/4W	144299
R10	RES MF 12.1K 1% 1/4W	144154
R11	RES MF 3.32K 1% 1/4W	144095
R12	RES MF 20K 1% 1/4W	144104
R13	RES MF 2.1K 1% 1/4W	144299
R14	RES MF 150K 1% 1/4W	144419
R15	RES WW 2.7 OHM 10W	139173
R16	RES WW 2.7 OHM 10W	139173
SP1	BRACKET PCB CARD MOUNTING	003611
SP2	BRACKET PCB CARD MOUNTING	003611
SP3	BRACKET PCB CARD MOUNTING	003611
SP4	BRACKET PCB CARD MOUNTING	003611
U1	IC REGULATOR 15V	133154
U2	IC REGULATOR -15V	133153

4 049755 INPUT

C1	CAP ELECT 10UF 50V	066445
C2	CAP ELECT 10UF 50V	066445
C3	CAP ELECT 10UF 50V	066445
C4	CAP ELECT 10UF 50V	066445
C5	CAP MONO 47PF 200V 10% NPO	061299
C6	CAP MONO 22PF 200V 10% NPO	061298
C7	CAP MONO 47PF 200V 10% NPO	061299
C8	CAP MONO 22PF 200V 10% NPO	061298
C9	CAP MONO 22PF 200V 10% NPO	061298
C10	CAP MONO 22PF 200V 10% NPO	061298
C11	CAP MONO .1uF 50V 20% Z5U	061305
C12	CAP ELECT 10UF 50V	066445
C13	CAP MPF 0.22UF 5% 63VDC	064329
C14	CAP MONO .1uF 50V 20% Z5U	061305
C15	CAP MONO .1uF 50V 20% Z5U	061305
J1	XLR FEM HORIZ PCB WITH LATCH	117814
J2	XLR FEM HORIZ PCB WITH LATCH	117814
J3	JACK PHONO GOLD PJ261G	117436
J4	JACK HEADPHONE DUAL BLK 1/8	117825
J5	CONN MALE 9 POS FRICTION LK	117244
J6	CONN MALE 9 POS FRICTION LK	117244
R1	RES MF 20K 1% 1/4W	144104
R2	RES MF 20K 1% 1/4W	144104
R3	RES MF 20K 1% 1/4W	144104
R4	RES MF 20K 1% 1/4W	144104
R5	RES MF 20K 1% 1/4W	144104
R6	RES MF 20K 1% 1/4W	144104
R7	RES MF 20K 1% 1/4W	144104
R8	RES MF 20K 1% 1/4W	144104
R9	RES MF 40.2K 1% 1/4W	144107
R10	RES MF 40.2K 1% 1/4W	144107
R11	RES MF 20K 1% 1/4W	144104
R12	RES MF 40.2K 1% 1/4W	144107
R13	RES MF 1K 1% 1/4W	144090
R14	RES MF 20K 1% 1/4W	144104
R15	RES MF 1K 1% 1/4W	144090
R16	RES MF 40.2K 1% 1/4W	144107

R17	RES MF 20K 1% 1/4W	144104
R18	RES MF 20K 1% 1/4W	144104
R19	RES MF 3.32K 1% 1/4W	144095
R20	RES MF 3.32K 1% 1/4W	144095
R21	RES MF 20K 1% 1/4W	144104
R22	RES MF 100 OHM 1% 1/4W	144196
R23	RES MF 68.1 OHM 1% 1/4W	144082
R24	RES MF 1M 1/4W	144269
R25	RES MF 20K 1% 1/4W	144104
R26	RES MF 10 OHM 1% 1/4W	144157
R27	RES MF 10 OHM 1% 1/4W	144157
S1	JSA4320-0201	148069
SP1	BRACKET PCB CARD MOUNTING	003611
U1	IC OPAMP NE4558N	133028
U2	IC NAND SCHMIT 2-IN X 4	133192
U3	IC REGULATOR +5 VOLT	133093

5 049756 METER/LIGHTING

C4	CAP MONO .1uF 50V 20% Z5U	061305
C5	CAP MONO .1uF 50V 20% Z5U	061305
C8	CAP MPF 0.22UF 5% 63VDC	064329
C9	CAP MPF 0.1UF 100V	064337
C10	CAP ELECT 10UF 50V	066445
C11	CAP MONO .1uF 50V 20% Z5U	061305
C12	CAP MONO .1uF 50V 20% Z5U	061305
C13	CAP MPF 0.22UF 5% 63VDC	064329
C14	CAP MPF 0.1UF 100V	064337
C15	CAP ELECT 10UF 50V	066445
D1	DIODE ZENER 8.2V 1/2W	070130
D9	LED AMBER	058133
D13	LED AMBER	058133
D14	DIODE SILICON	070047
D15	DIODE SILICON	070047
D16	DIODE SILICON	070047
D17	DIODE SILICON	070047
D18	DIODE SILICON	070047
D19	DIODE SILICON	070047
D20	DIODE SILICON	070047
D21	DIODE SILICON	070047
D22	DIODE SILICON	070047
D23	DIODE SILICON	070047
D24	DIODE SILICON	070047
D25	DIODE SILICON	070047
DS5	LED GREEN 5MM HI-INTENSITY	058165
DS6	LED GREEN 5MM HI-INTENSITY	058165
DS7	LED GREEN 5MM HI-INTENSITY	058165
DS8	LED SQUARE RED	058109
J1	CONN MALE 9 POS FRICTION LK	117244
J2	CONN 4 PIN	117215
J3	CONN 3 POS MLE MTS100 NORM	117214
J4	HEADER 2 PIN LATCHING	117766
J5	CONN 4 PIN	117215
J6	HEADER 2 PIN LATCHING	117766
Q1	TRANSISTOR NPN	132223
Q2	TRANSISTOR NPN	132223
Q3	TRANSISTOR NPN	132223
Q4	TRANSISTOR NPN	132223
Q8	TRANSISTOR NPN	132223
Q9	TRANSISTOR NPN	132223
Q10	TRANSISTOR NPN	132223
Q11	TRANSISTOR NPN	132223
Q12	TRANSISTOR NPN	132223
Q13	TRANSISTOR NPN	132223
Q14	TRANSISTOR NPN	132223
Q15	TRANSISTOR NPN	132223
R6	RES MF 187K 1% 1/4W	144406
R8	RES MF 12.1K 1% 1/4W	144154
R9	RES MF 475K 1% 1/4W	144364

R11	RES MF 4.75K 1% 1/4W	144097
R13	RES MF 681 OHM 1% 1/4W	144195
R18	RES MF 12.1K 1% 1/4W	144154
R19	RES MF 4.75K 1% 1/4W	144097
R28	RES MF 562 OHM 1/4W	144408
R29	RES MF 806 OHM 1/4W	144089
R37	RES MF 187K 1% 1/4W	144406
R38	RES MF 681 OHM 1% 1/4W	144195
R39	RES MF 475K 1% 1/4W	144364
R40	RES MF 200K 1/4W	144117
R41	RES MF 10.2K 1% 1/4W	144130
R42	RES MF 10M 1% 1/4W	144264
R43	RES MF 2.21M 1/4W	144265
R44	RES MF 100 OHM 1% 1/4W	144196
R45	RES MF 187K 1% 1/4W	144406
R46	RES MF 1.21K 1% 1/4W	144191
R47	RES 82.5K 1/4W	144112
R48	POT TRIM 100K OHM 20%	134383
R49	RES MF 221K 1% 1/4W	144421
R50	RES MF 6.81K 1/4W	144297
R51	RES MF 100 OHM 1% 1/4W	144196
R53	RES MF 200K 1/4W	144117
R54	RES MF 10.2K 1% 1/4W	144130
R55	RES MF 10M 1% 1/4W	144264
R56	RES 82.5K 1/4W	144112
R57	RES MF 2.21M 1/4W	144265
R58	RES MF 187K 1% 1/4W	144406
R59	RES MF 6.81K 1/4W	144297
R60	POT TRIM 100K OHM 20%	134383
R61	RES MF 1.21K 1% 1/4W	144191
U1	IC DUAL OPERATIONAL AMP	133260
U2	IC DUAL OPERATIONAL AMP	133260

6 049758 METER LED

DS1	LED BLUE 5MM HI-INTENSITY	058166
DS2	LED BLUE 5MM HI-INTENSITY	058166
DS3	LED GREEN 5MM HI-INTENSITY	058165
DS4	LED GREEN 5MM HI-INTENSITY	058165
DS5	LED BLUE 5MM HI-INTENSITY	058166
DS6	LED BLUE 5MM HI-INTENSITY	058166
DS7	LED GREEN 5MM HI-INTENSITY	058165
DS8	LED GREEN 5MM HI-INTENSITY	058165
J1	CONN 4 PIN RIGHT ANGLE	117240
R1	RES MF 221 OHM 1% 1/4W	144172
R2	POT TRIM 500 OHM 20% HOR ADJ	134410
R3	RES MF 221 OHM 1% 1/4W	144172
R4	POT TRIM 500 OHM 20% HOR ADJ	134410
R5	RES MF 221 OHM 1% 1/4W	144172
R6	POT TRIM 500 OHM 20% HOR ADJ	134410
R7	RES MF 221 OHM 1% 1/4W	144172
R8	POT TRIM 500 OHM 20% HOR ADJ	134410

EXPLODED VIEW

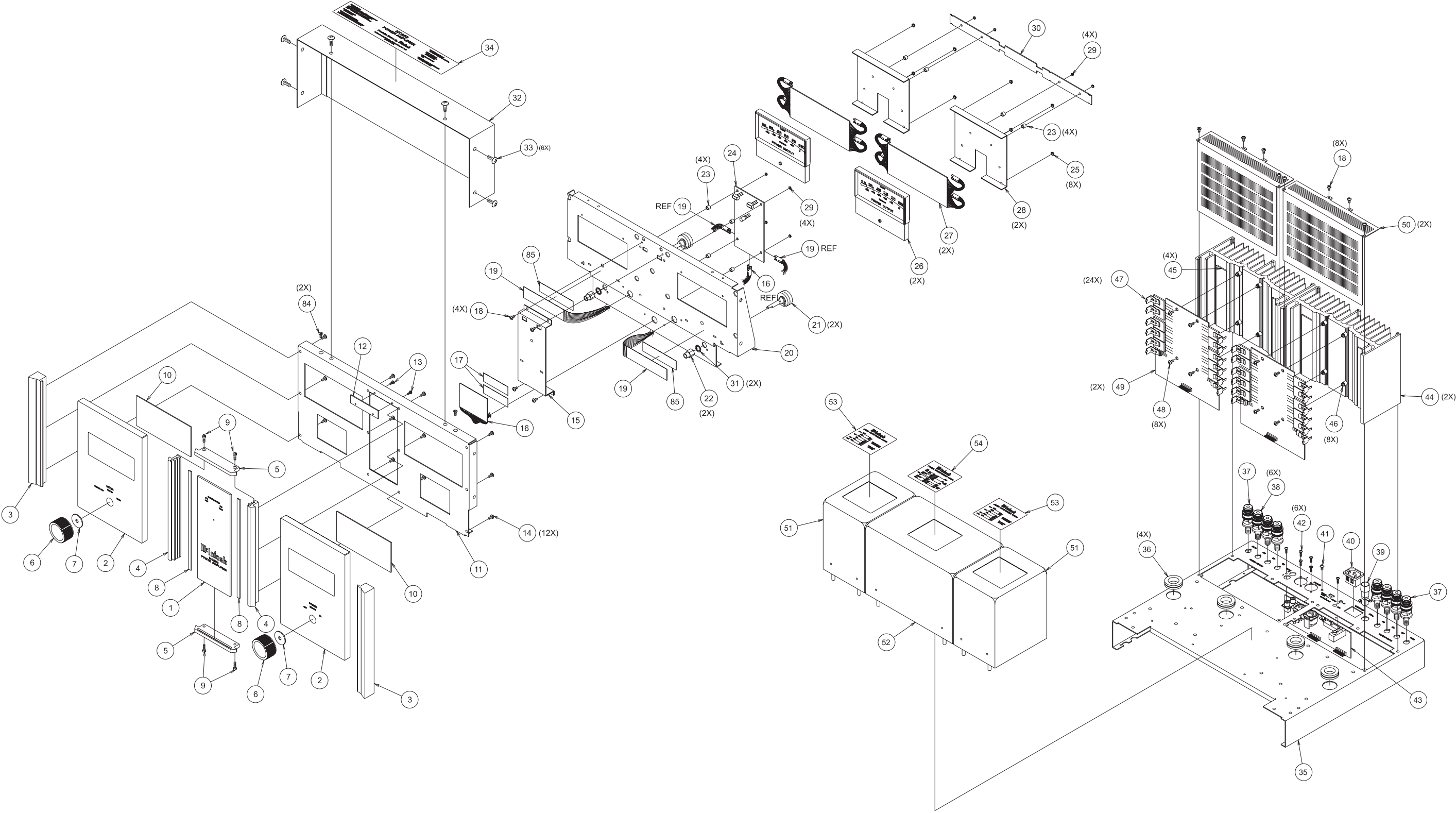

EXPLODED VIEW con't

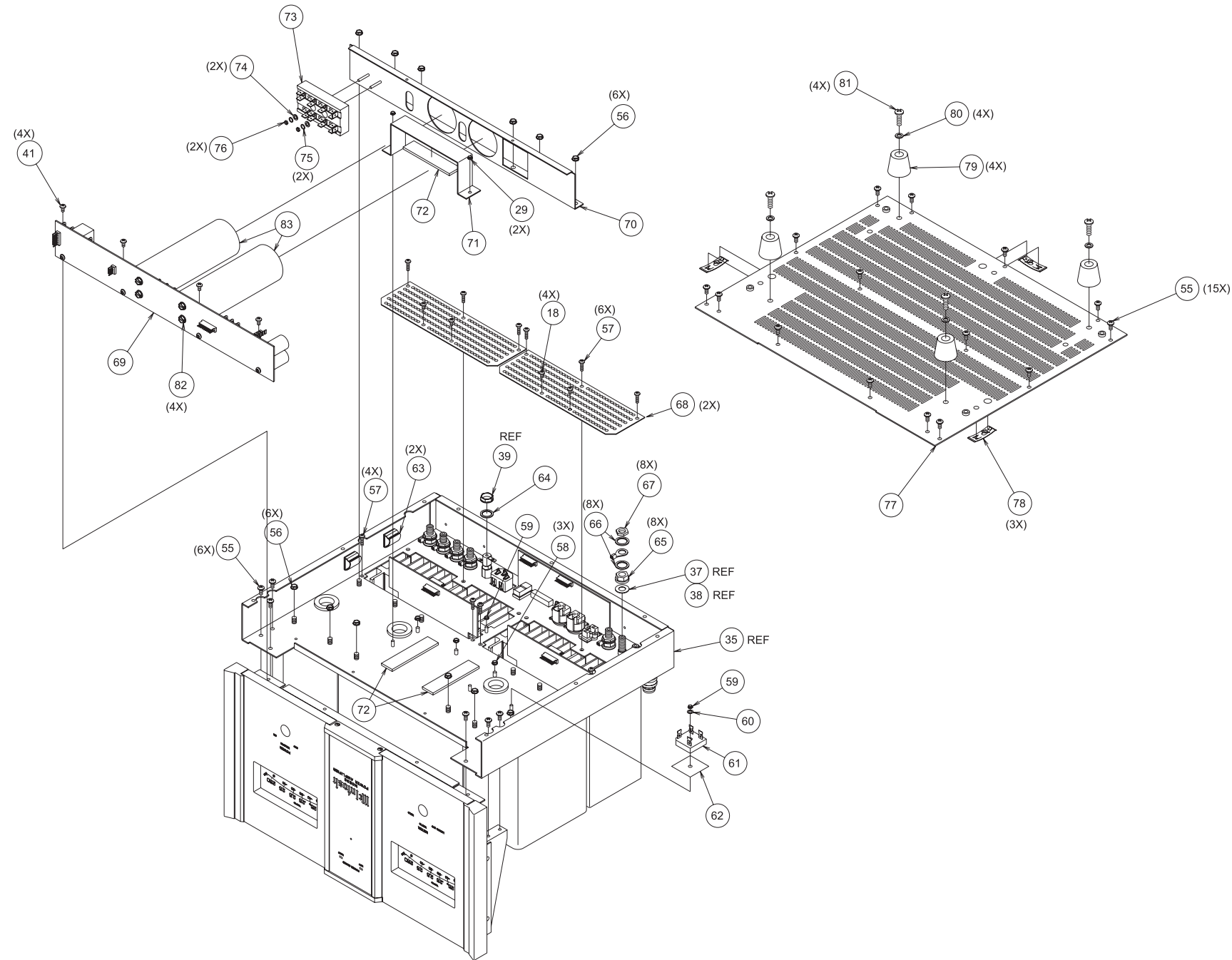

EXPLODED VIEW PARTS LIST

Ref No.	Part No.	Description
1	016469	GLASS CENTER PANEL
2	016487	GLASS PANEL W/HOLE
3	018717	END CAP
4	018711	CENTER EXTRUSION
5	018710	TOP/BOTTOM END CAP
6	049321	ASSY KNOB
7	104164	WASHER BLK FELT 1 X 1/4 X 1/16
8	094016	TAPE FOAM 1/4 X 1/8
9	100342	SCREW 6-32 X 3/8 FILLISTER HD
10	092426	FILTER COLOR METER
11	005351	GLASS PANEL, PLATE
12	005312	PLATE GAP
13	101074	SCREW TAPPING 4-40 X 1/4 PH PN
14	100276	SCREW MACH SEMS 6-32 X 5/16 PH PN
15	005237	TITLE MOUNT
16	017913	LOGO BACKLIGHT
17	094430	TAPE FOAM WHITE 1/2W X 1/8 THK
18	101054	SCREW TAPTITE 6-32 X 1/4 PH PN
19	017901	LOGO PUSHBUTTON BACKLIGHT
20	005239	SUBPANEL
21	146243	SWITCH POWER
22	021159	BUSHING SWITCH
23	021030	SPACER 6 X 1/4
24	049756	ASSY METER/LIGHTING PCB
25	102001	NUT KEP 4-40 CADMIUM PLATE
26	124084	METER
27	017881	BACKLIGHT METER
28	005229	METER PLATE
29	102045	NUT KEP 6-32 SPECIAL
30	049758	ASSY METER LED PCB
31	104014	WASHER INT STAR 3/8 X .507 X .002
32	005236	DUST COVER
33	100200	SCREW MACH 10-32 X 1/2 PH TRS HD
34	126948	DECAL TOP COVER
35	005234	CHASSIS
36	078025	GROMMET RUBBER 3/4ID
37	117741	POST BINDING BLK
38	117740	POST BINDING RED
39	178161	HOLDER FUSE 5 X 20mm IEC
40	117487	RECEPTACLE AC LINE
41	100250	SCREW MACH SEMS 6-32 X 1/4 PH PN
42	101197	SCREW HI-LO 4-24 X 3/8 PH HD BLK
43	049755	ASSY INPUT PCB
44	018690	HEATSINK
45	084206	ISOSTRATE
46	112087	SPACER PCB 1/4
47	114141	CLIP RIGHT ANGLE
48	101059	SCREW SM 6 X 5/8 PH PN TYPE A
49	049986	ASSY HEATSINK PCB
50	005235	HEATSINK COVER
51	049766	POTTED TRANSFORMER OUTPUT
52	049763	POWER TRANSFORMER POWER
53	126946	DECAL OUTPUT TRANSFORMER
54	126947	DECAL POWER TRANSFORMER
55	101078	SCREW TAP 8-32 X 5/16 PH PN BLK
56	102006	NUT MACH 10-32 W/LOCK
57	101176	SCREW TC 6-32 X 1/2 PH PN TYPE F
58	102005	NUT MACH 8-32 W/LOCK
59	102003	NUT MACH 6-32 W/LOCK
60	104005	WASHER FLAT STEEL 6 X 3/8 X .032
61	070139	DIODE BRIDGE RECTIFIER
62	084135	THERMAL PAD
63	017452	KLIP WIRE
64	104016	WASHER INT STAR .5 X .630 X .022
65	102052	NUT GOLD SUPPLIED W/117758
66	104162	WASHER LOCK INTERNAL TOOTH
67	102051	NUT HEX M9 X .75 GOLD PLATED
68	005240	HEATSINK VENT
69	049757	ASSY POWER SUPPLY PCB
70	005238	CHASSIS SUPPORT BRACKET
71	005308	CAPACITOR STRAP
72	094391	TAPE FOAM 1/8 X 3/4 3M #4508
73	074091	TERMINAL BLOCK AC
74	104001	WASHER FLAT STEEL 4 X 9/32 X .025
75	104004	WASHER LOCK 5 X .255 INT STAR
76	102022	NUT MACH 4-40 X 3/16 X 1/16
77	005242	BOTTOM COVER
78	106007	SPRING CLIP LATCH TYPE
79	017218	FOOT PLASTIC BLK
80	104080	WASHER FELT #10 CLEAR ZINC
81	100159	SCREW MACH 10-32 X 3/4 PH PN BLK
82	100188	SCREW MACH SEMS 10-32 X 3/8
83	066489	CAP ELECT 2700uF 100V
84	101172	SCREW TC 6-32 X 1/4 PH FL U/C
85	094429	TAPE FOAM 1/32 THK

REPACKING INSTRUCTIONS

In the event it is necessary to repack the unit for shipment, the unit must be packed exactly as shown below.

IMPORTANT - The four plastic feet must be attached to the bottom of the unit so they will locate in the four holes of the bottom pad. Two #10 x 2-1/4" screws and washers must be used to fasten the unit securely to the bottom pad and wood skid. Failure to do this will result in shipping damage.

If a shipping carton or any of the interior parts is needed, please call or write the Customer Service Department of McIntosh Laboratory. Order parts from the accompanying list by part number.

Use the original shipping carton and interior parts only if they are in good serviceable condition.

Qty.	Part No.	Description
1	034198	Inner carton top
1	034188	Inner carton foam pad
4	017218	Plastic foot (unit)
1	033739	Poly bag
4	100159	#10-32 x 3/4" Machine screw
4	104083	#10 x 7/16" Flat washer
1	034194	Bottom pad
3	017218	Plastic foot (spacer)
1	033699	Shipping skid
3	101204	#10 x 2-1/2" Wood screw
3	104033	#10 x 1-3/4" Flat washer
2	034250	Foam end caps
1	034158	Shipping carton
1	034199	Inner carton bottom
1	034249	Slit Scored Wrap

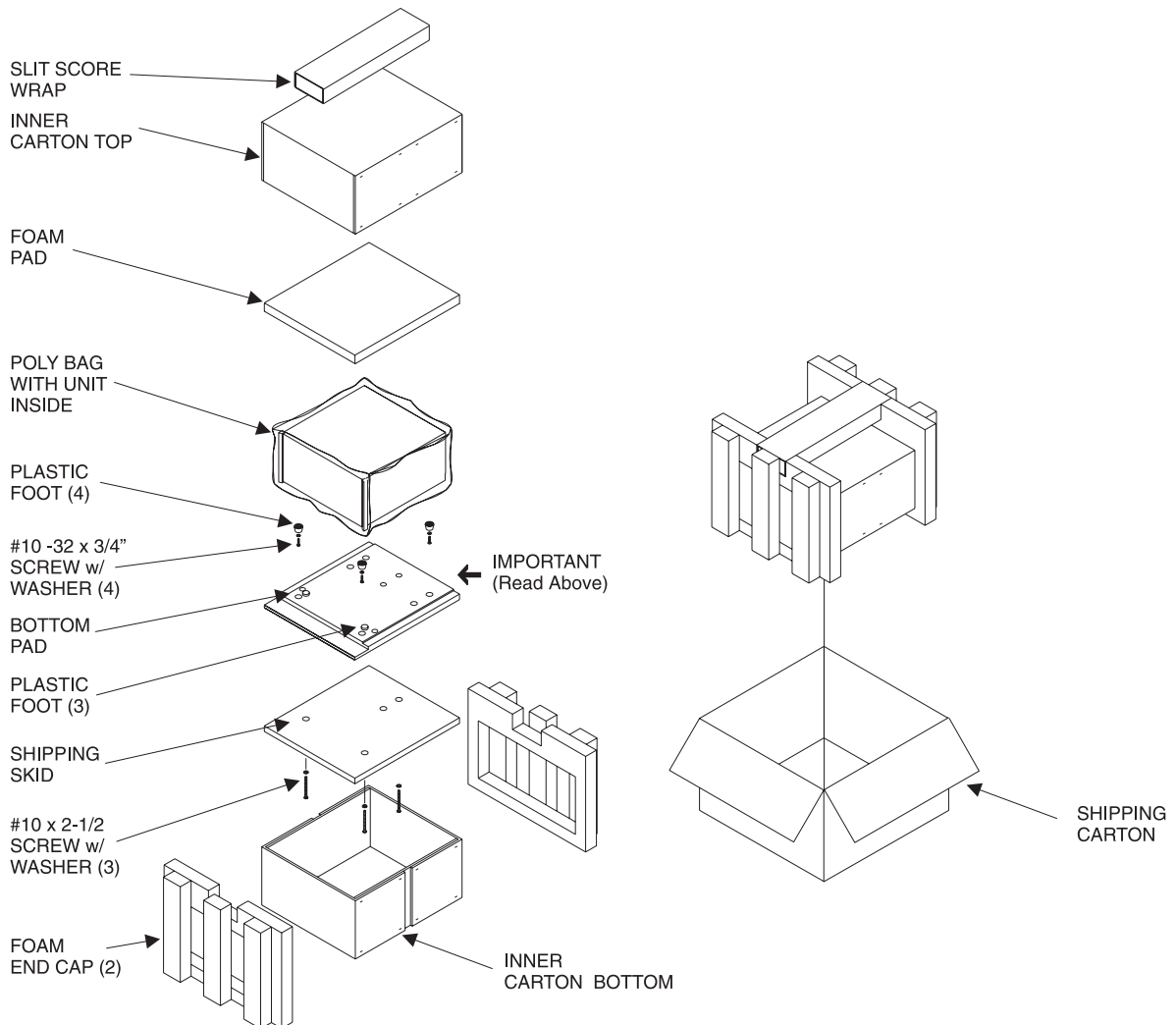

MC252

POWER AMPLIFIER

SERVICE MANUAL

The continuous improvement of its products is the policy of McIntosh Laboratory Incorporated, who reserve the right to improve design without notice. Because of the constant upgrading of McIntosh products' circuitry and components, the Company cannot insure, and does not warrant, the accuracy of the within schematic material, which is intended for information only.