

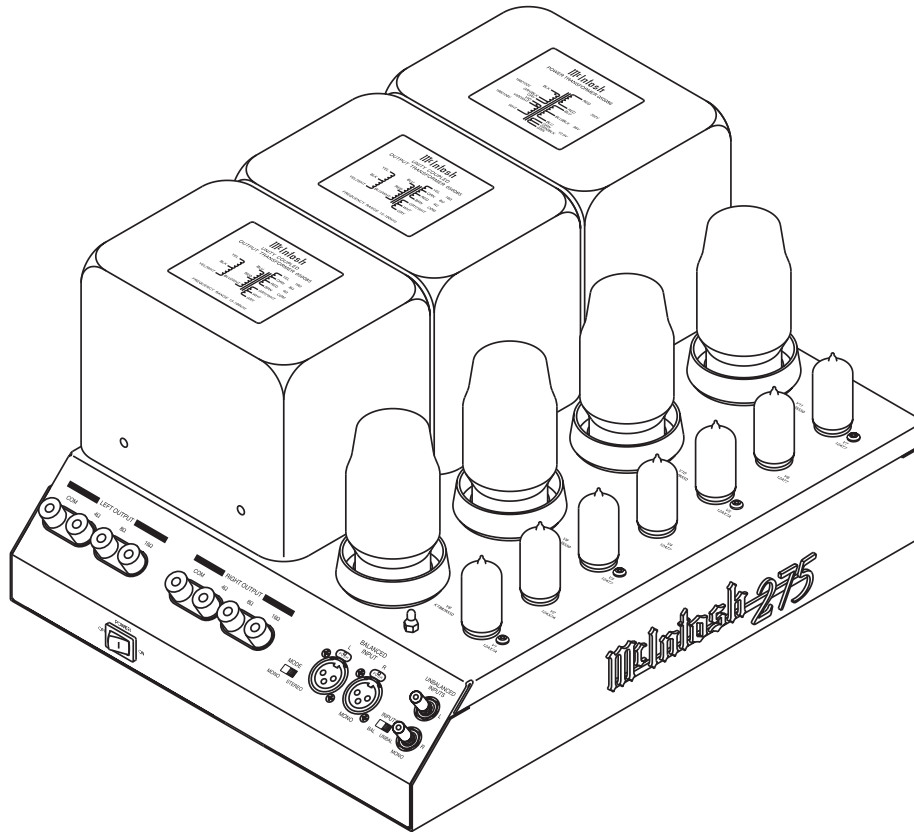

MC275

STEREO POWER AMPLIFIER

STARTING WITH SERIAL NO. WV1536



CONTENTS

Performance Specifications	2	Amplifier Schematic and PCB	9 - 12
Notes	2	Input Schematic and PCB	13 - 14
Rear Panel	3	Parts List	15 - 16
Section Location	4	Exploded View and Parts List	17 - 18
Block Diagram	5	Repacking Instructions	19
Interconnection Diagram	7 - 8		

McIntosh®

SERVICE MANUAL

PERFORMANCE SPECIFICATIONS

Power Output Stereo

Minimum sine wave continuous average power output per channel, both channels operating is:
75 watts into 4, 8 or 16 ohm load

Power Output Mono (Parallel)

Minimum sine wave continuous average power output is:
150 watts into 2 ohm, 4 ohm or 8 ohm load

Output Load Impedance

4, 8, or 16 ohm (Stereo Mode)
2, 4, or 8 ohm (Mono Mode)

Rated Power Band

20Hz to 20,000Hz

Total Harmonic Distortion

Maximum Total Harmonic Distortion at any power level from 250 milliwatts to rated power output is 0.5%

Intermodulation Distortion

Maximum Intermodulation Distortion if instantaneous peak output per channel does not exceed twice the rated output, for any combination of frequencies from 20Hz to 20,000Hz, with both channels operating is 0.5%

A-Weighted Signal To Noise Ratio

100dB

Frequency Response

+0, -0.5dB from 20Hz to 20,000Hz
+0, -3dB from 10Hz to 70,000Hz

Sensitivity

1.2 Volt unbalanced inputs
2.5 Volt balanced inputs

Wide Band Damping Factor

Greater than 14

Input Impedance

90,000 ohms unbalanced
180,000 balanced

Tube Compliment

3 - 12AX7A Inputs and Phase Inverters
4 - 12AT7 Voltage Amplifier and Drivers
4 - KT88/6550 Power Output

Power Requirements

100 Volts, 50/60Hz at 360 watts
110 Volts, 50/60Hz at 3.6 amps
120 Volts, 50/60Hz at 3.6 amps
220 Volts, 50/60Hz at 1.8 amps
230 Volts, 50/60Hz at 1.8 amps
240 Volts, 50/60Hz at 1.8 amps

Note: Refer to the right side panel of the MC275 for the correct voltage.

Overall Dimensions

Width is 16-1/2 inches (41.91cm), Height is 8-1/4 inches (20.96cm) including feet, Depth is 12 inches (30.48cm)

Weight

67 pounds (30.5kg) net, 75 pounds (34.1kg) in shipping carton

NOTES

1. The heavy lines on the schematic denote the primary signal path.
2. Unless otherwise noted, all voltages indicated on the schematics are measured under the following conditions:
 - a. AC input at 120 volts, 50/60Hz.
 - b. All voltages are +/-10% with respect to ground. A high impedance (10 megaohm) voltmeter must be used.
3. Unless otherwise specified:
 - a. Resistor values are in ohms.
 - b. Capacitor values are microfarads (uF).
 - c. Inductor values are in microhenries (uH).
4. On PC board drawings, Square pad indicates:
 - a. Polarized Capacitors - Positive
 - b. Diodes - Cathode
 - c. Others - Pin 1
5. **WARNING**
Parts marked with the symbol  have critical characteristics. Use only replacement parts recommended by the manufacturer.

SECTION LOCATIONS

TOP VIEW WITH COVER REMOVED

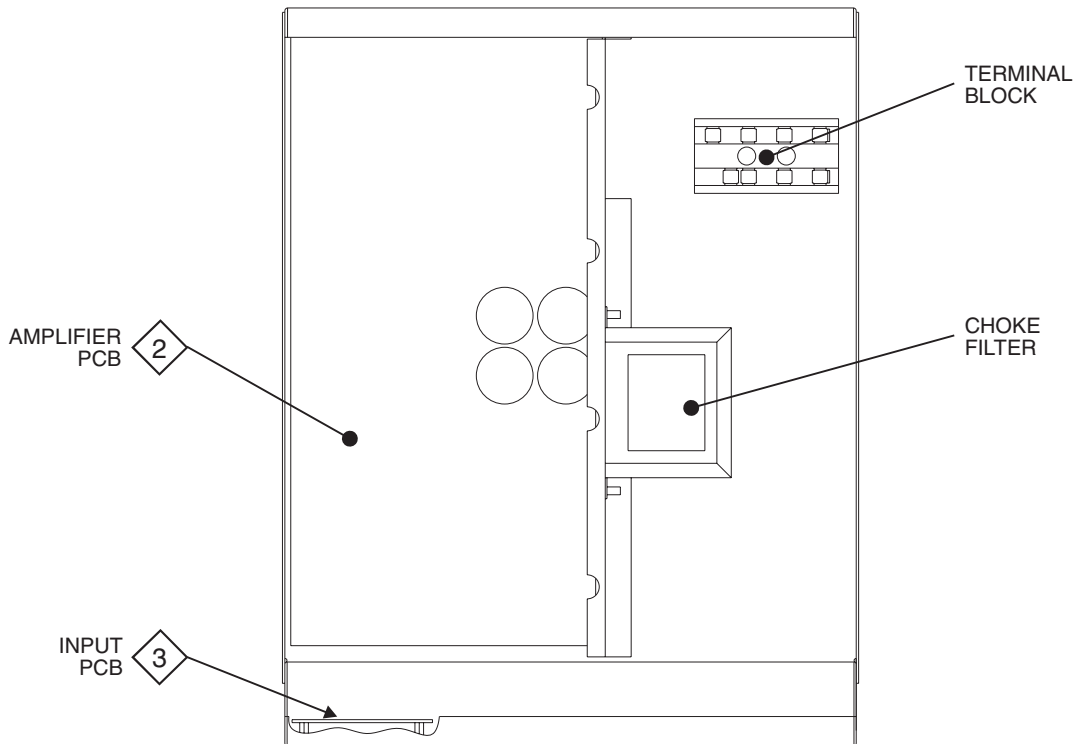
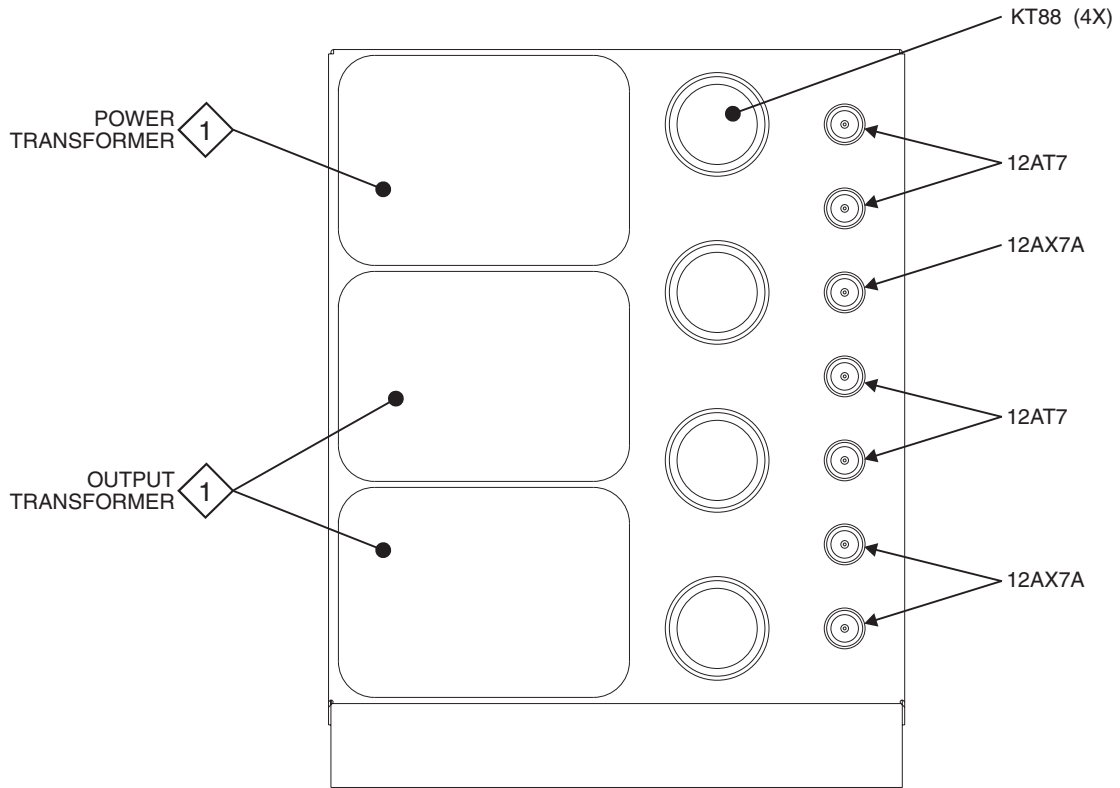

BOTTOM VIEW WITH COVER REMOVED

BLOCK DIAGRAM

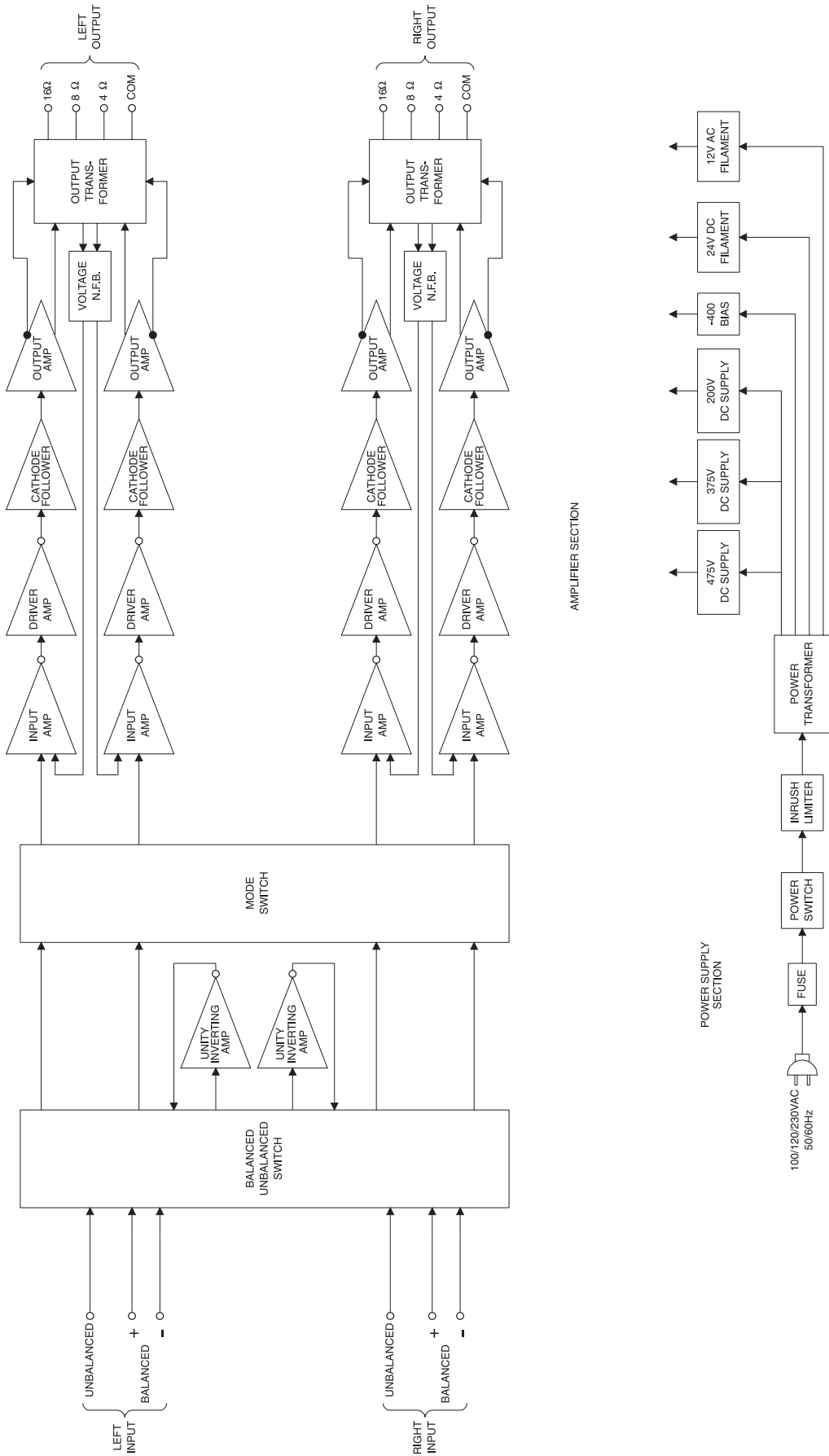

1 INTERCONNECT

! WARNING Parts located in the shaded area have critical characteristics. Use only replacement parts recommended by the manufacturer.

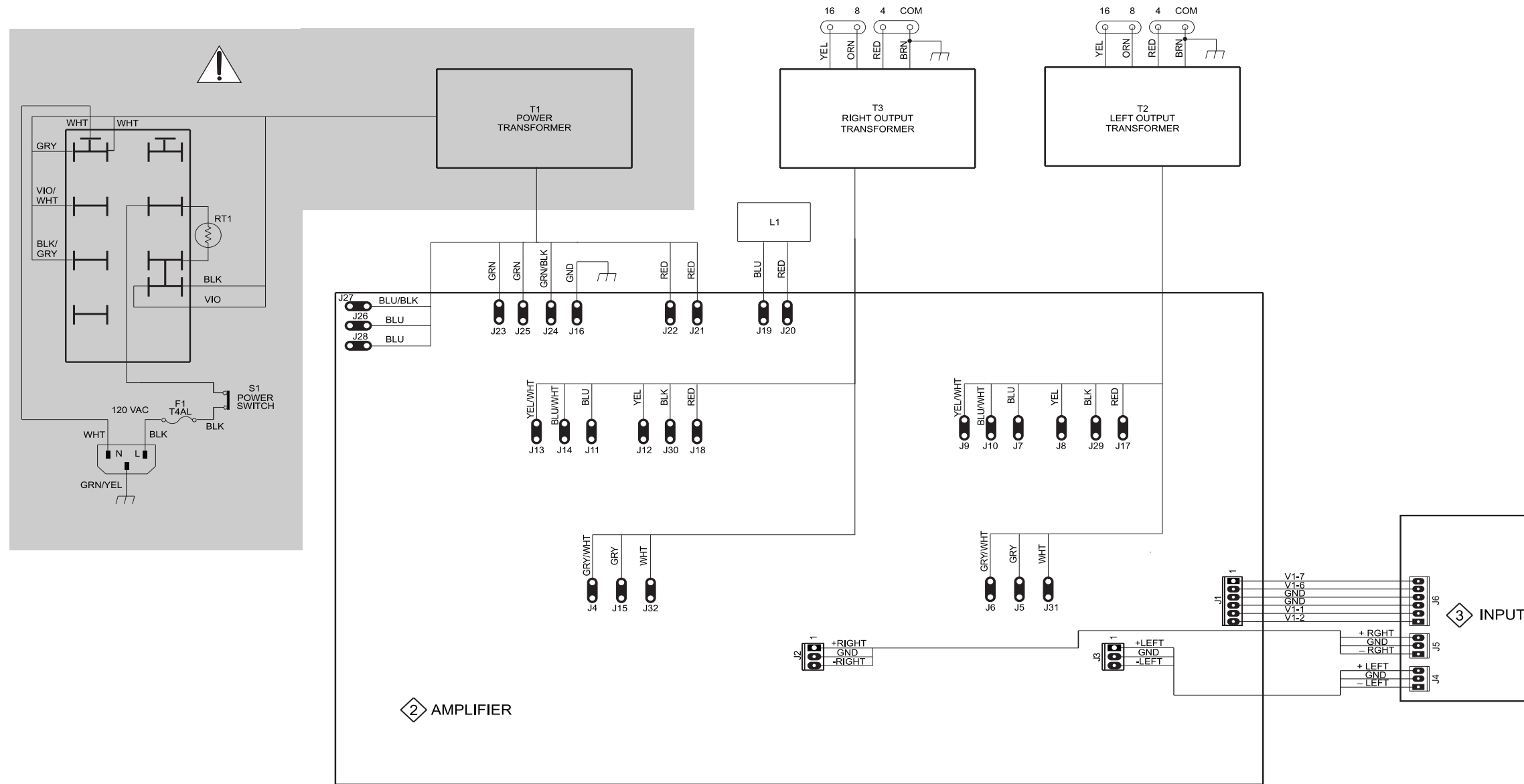

3 INPUT 750082

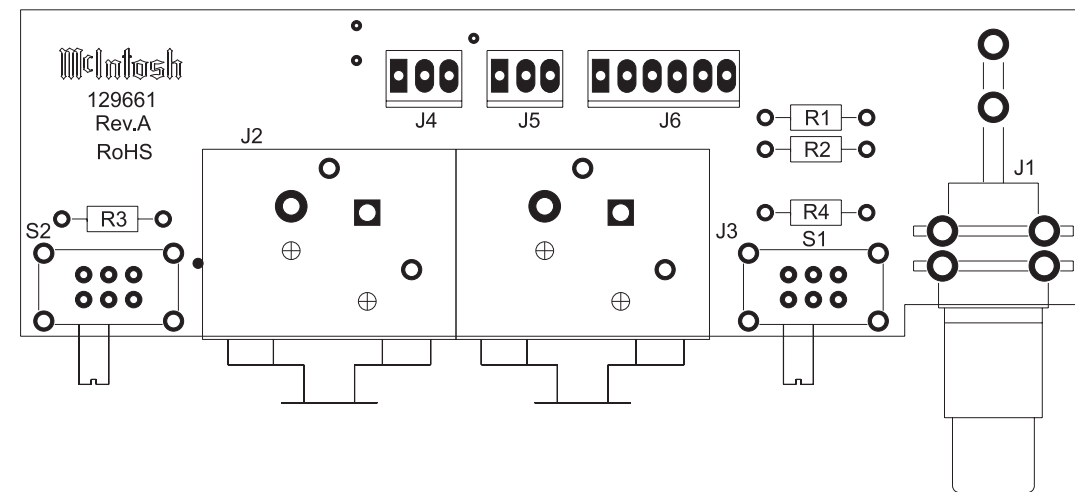
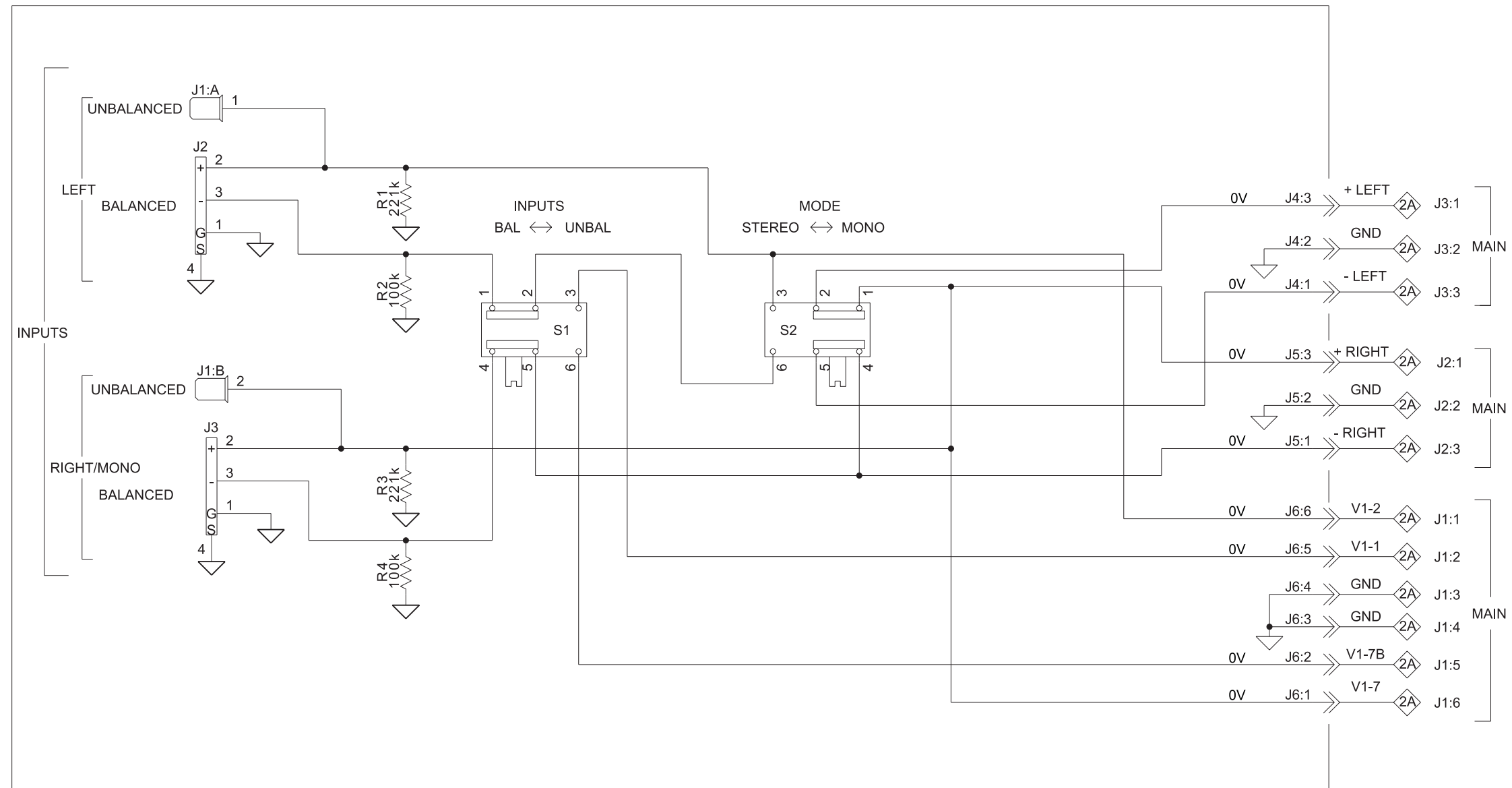

PARTS LIST

Ref. No.	Description	Part No.	Ref. No.	Description	Part No.
1 INTERCONNECT					
F1	FUSE 4A 250V SLO-BLO 5X20 IEC	089135	F1	FUSE 2A 250V SLO-BLO 5X20 IEC	089123
L1	CHOKE FILTER 0.5H 800MA SLOTS	122379	F2	FUSE 2A 250V SLO-BLO 5X20 IEC	089123
RT1	ASSEMBLY THERMISTOR CL-40 5R	052008	F3	FUSE T8AL 250V SLO-BLO 5X20 IEC	089134
S1	CABLE ASSY PWR SWCH	171729	F4	FUSE T8AL 250V SLO-BLO 5X20 IEC	089134
T1	POTTED TRANSFORMER POWER	750086	J1	CONN MALE 6 POS FRICTION LOCK	117218
T2	POTTED TRANSFORMER OUTPUT	750085	J2	CONN 3 POS MALE MTS100 NORMAL	117214
T3	POTTED TRANSFORMER OUTPUT	750085	J3	CONN 3 POS MALE MTS100 NORMAL	117214
			J4	BLADE FASTON W/FEET	117708
			J5	BLADE FASTON W/FEET	117708
			J6	BLADE FASTON W/FEET	117708
			J7	BLADE FASTON W/FEET	117708
			J8	BLADE FASTON W/FEET	117708
			J9	BLADE FASTON W/FEET	117708
			J10	BLADE FASTON W/FEET	117708
			J11	BLADE FASTON W/FEET	117708
			J12	BLADE FASTON W/FEET	117708
			J13	BLADE FASTON W/FEET	117708
			J14	BLADE FASTON W/FEET	117708
			J15	BLADE FASTON W/FEET	117708
			J16	BLADE FASTON W/FEET	117708
			J17	BLADE FASTON W/FEET	117708
			J18	BLADE FASTON W/FEET	117708
			J19	BLADE FASTON .187	117726
			J20	BLADE FASTON .187	117726
			J21	BLADE FASTON W/FEET	117708
			J22	BLADE FASTON W/FEET	117708
			J23	BLADE FASTON W/FEET	117708
			J24	BLADE FASTON W/FEET	117708
			J25	BLADE FASTON W/FEET	117708
			J26	BLADE FASTON W/FEET	117708
			J27	BLADE FASTON W/FEET	117708
			J28	BLADE FASTON W/FEET	117708
			J29	BLADE FASTON W/FEET	117708
			J30	BLADE FASTON W/FEET	117708
			J31	BLADE FASTON W/FEET	117708
			J32	BLADE FASTON W/FEET	117708
			L1	CHOKE 2.2 UH	122405
			L2	CHOKE 2.2 UH	122405
			L3	CHOKE 2.2 UH	122405
			L4	CHOKE 2.2 UH	122405
			R1	RES MF 1M 1% 1/4W	144577
			R2	RES MF 1M 1% 1/4W	144577
			R3	RES MF 221K 1% 1/4W	144629
			R4	RES MO 100K 5% 2W	144698
			R5	RES MO 100K 5% 2W	144698
			R6	RES MF 221K 1% 1/4W	144629
			R7	RES MF 221K 1% 1/4W	144629
			R8	RES MF 221K 1% 1/4W	144629
			R9	RES MF 1K 1% 1/4W	144513
			R10	RES MF 1K 1% 1/4W	144513
			R11	RES MF 100K 1% 1/2W	144635
			R12	RES MF 100K 1% 1/2W	144635
			R13	RES MF 1M 1% 1/4W	144577
			R14	RES MF 1M 1% 1/4W	144577
			R15	RES MF 1M 1% 1/4W	144577
			R16	RES MF 1M 1% 1/4W	144577
			R17	RES MF 10K 1% 1/4W	144504
			R18	RES MF 10K 1% 1/4W	144504
			R19	RES MF 10K 1% 1/4W	144504
			R20	RES MF 10K 1% 1/4W	144504
			R21	RES MF 100 OHM 1% 1/4W	144568
			R22	RES MF 100 OHM 1% 1/4W	144568
2 750675 AMPLIFIER PCB					
C1	CAP ELECT 47UF 450V	066560			
C2	CAP MPF 0.1UF 630VDC	064431			
C3	CAP MPF 0.1UF 630VDC	064431			
C4	CAP ELECT 100UF 25V	066573			
C5	CAP ELECT 100UF 25V	066573			
C6	CAP MPF 0.1UF 5% 63VDC	064325			
C7	CAP MPF 0.1UF 5% 63VDC	064325			
C8	CAP MPF 0.1UF 5% 63VDC	064325			
C9	CAP MPF 0.1UF 5% 63VDC	064325			
C10	CAP ELECT 470UF 16V	066508			
C11	CAP ELECT 470UF 16V	066508			
C12	CAP PF 0.001UF 5% 63VDC	064453			
C13	CAP PF 0.001UF 5% 63VDC	064453			
C14	CAP MPF 0.0022UF 5% 63VDC	064454			
C15	CAP MPF 0.0022UF 5% 63VDC	064454			
C16	CAP MPF 0.1UF 630VDC	064431			
C17	CAP MPF 0.1UF 630VDC	064431			
C18	CAP MPF 0.1UF 630VDC	064431			
C19	CAP MPF 0.1UF 630VDC	064431			
C20	CAP ELECT 470UF 50V	066469			
C21	CAP ELECT 470UF 50V	066469			
C22	CAP POLYPROP 0.22UF 20% 1KVDC	064432			
C23	CAP POLYPROP 0.22UF 20% 1KVDC	064432			
C24	CAP POLYPROP 0.22UF 20% 1KVDC	064432			
C25	CAP POLYPROP 0.22UF 20% 1KVDC	064432			
C26	CAP POLY .047UF 10% 1000VDC	064434			
C27	CAP POLYPROP .047UF 10% 250VDC	064364			
C28	CAP ELECT 680UF 315V	066549			
C29	CAP ELECT 680UF 315V	066549			
C30	CAP ELECT 4700UF 35V	066541			
C31	CAP ELECT 680UF 315V	066549			
C32	CAP ELECT 680UF 315V	066549			
C33	CAP ELECT 47UF 450V	066560			
C34	CAP ELECT 47UF 450V	066560			
C35	CAP ELECT 47UF 450V	066560			
C36	CAP MPF 0.22UF 5% 63VDC	064329			
C37	CAP MPF 0.22UF 5% 63VDC	064329			
D1	DIODE ZENER 200V 1.5W	070177			
D2	DIODE ZENER 200V 1.5W	070177			
D3	DIODE ZENER 200V 1.5W	070177			
D4	DIODE ZENER 200V 1.5W	070177			
D5	DIODE ZENER 200V 1.5W	070177			
D6	DIODE ZENER 200V 1.5W	070177			
D7	DIODE ZENER 200V 1.5W	070177			
D8	DIODE ZENER 200V 1.5W	070177			
D9	DIODE ZENER 200V 1.5W	070177			
D10	DIODE BRIDGE RECT 1000V 6A	070180			
D11	DIODE SIL 400 PIV @ 1.5A	070031			
D12	DIODE SIL 400 PIV @ 1.5A	070031			
D13	DIODE RECTIFIER	070178			
D14	DIODE RECTIFIER	070178			

PARTS LIST *con't*

Ref. No.	Description	Part No.	Ref. No.	Description	Part No.
R23	RES MF 100 OHM 1% 1/4W	144568	R65	RES MO 100K 5% 2W	144698
R24	RES MF 100 OHM 1% 1/4W	144568	R66	RES MO 100K 5% 2W	144698
R25	RES MF 8.25K 1% 1/4W	144549	R67	RES MO 100K 5% 2W	144698
R26	RES MF 8.25K 1% 1/4W	144549	R68	RES MO 100K 5% 2W	144698
R27	RES MF 121K OHM 1% 1/2W	144588	R69	RES WW 220 OHM 10% 5W	139256
R28	RES MF 121K OHM 1% 1/2W	144588	R70	RES WW 220 OHM 10% 5W	139256
R29	RES MF 121K OHM 1% 1/2W	144588	R71	RES WW 220 OHM 10% 5W	139256
R30	RES MF 121K OHM 1% 1/2W	144588	R72	RES WW 220 OHM 10% 5W	139256
R31	RES 698 OHM 1% 1/4W	144511	R73	RES MO 10K 5% 2W	144638
R32	RES 698 OHM 1% 1/4W	144511	R74	RES MO 2.2K 5% 2W	144666
R33	RES 698 OHM 1% 1/4W	144511	R75	RES MO 100K 5% 2W	144698
R34	RES 698 OHM 1% 1/4W	144511	R76	RES MO 100K 5% 2W	144698
R35	RES MF 2.21M 1% 1/4W	144576	(F1)	HOLDER FUSE 5X20MM PCB MOUNT	178159
R36	RES MF 2.21M 1% 1/4W	144576	(F2)	HOLDER FUSE 5X20MM PCB MOUNT	178159
R37	RES MF 2.21M 1% 1/4W	144576	(F3)	HOLDER FUSE 5X20MM PCB MOUNT	178159
R38	RES MF 2.21M 1% 1/4W	144576	(F4)	HOLDER FUSE 5X20MM PCB MOUNT	178159
R39	RES MF 221K 1% 1/4W	144629	(V1)	SOCKET 9 PIN TUBE CERAMIC	178170
R40	RES MF 221K 1% 1/4W	144629	(V2)	SOCKET 9 PIN TUBE CERAMIC	178170
R41	RES MF 221K 1% 1/4W	144629	(V3)	SOCKET 9 PIN TUBE CERAMIC	178170
R42	RES MF 221K 1% 1/4W	144629	(V4)	SOCKET 9 PIN TUBE CERAMIC	178170
R43	RES MF 10K 1% 1/4W	144504	(V5)	SOCKET 9 PIN TUBE CERAMIC	178170
R44	RES MF 10K 1% 1/4W	144504	(V6)	SOCKET 9 PIN TUBE CERAMIC	178170
R45	RES MF 10K 1% 1/4W	144504	(V7)	SOCKET 9 PIN TUBE CERAMIC	178170
R46	RES MF 10K 1% 1/4W	144504	(V8)	SOCKET OCTAL TUBE CERAMIC	178169
R47	RES MO 46.4K 1% 1W	144637	(V9)	SOCKET OCTAL TUBE CERAMIC	178169
R48	RES MO 46.4K 1% 1W	144637	(V10)	SOCKET OCTAL TUBE CERAMIC	178169
R49	RES MO 46.4K 1% 1W	144637	(V11)	SOCKET OCTAL TUBE CERAMIC	178169
R50	RES MO 46.4K 1% 1W	144637			
R51	RES MF 90.9K 1% 1/4W	144557			
R52	RES MF 90.9K 1% 1/4W	144557			
R53	RES MF 1M 1% 1/4W	144577			
R54	RES MF 1M 1% 1/4W	144577			
R55	RES MF 1M 1% 1/4W	144577			
R56	RES MF 1M 1% 1/4W	144577			
R57	RES MF 200K 1% 1/4W	144531			
R58	RES MF 200K 1% 1/4W	144531			
R59	RES MF 200K 1% 1/4W	144531			
R60	RES MF 200K 1% 1/4W	144531			
R61	RES MO 100K 5% 2W	144698			
R62	RES MO 100K 5% 2W	144698			
R63	RES MO 100K 5% 2W	144698			
R64	RES MO 100K 5% 2W	144698			

			3	750082 INPUT PCB	
			J1	JACK PHONO GOLD	117862
			J2	XLR FEMALE HORIZ PCB WITH LATCH	117814
			J3	XLR FEMALE HORIZ PCB WITH LATCH	117814
			J4	CONN 3 POS MALE MTS100 NORMAL	117214
			J5	CONN 3 POS MALE MTS100 NORMAL	117214
			J6	CONN MALE 6 POS FRICTION LOCK	117218
			R1	RES MF 221K 1% 1/4W	144629
			R2	RES MF 100K 1% 1/4W	144528
			R3	RES MF 221K 1% 1/4W	144629
			R4	RES MF 100K 1% 1/4W	144528
			S1	SWITCH SLIDE DPDT	148076
			S2	SWITCH SLIDE DPDT	148076

EXPLODED VIEW and PARTS LIST

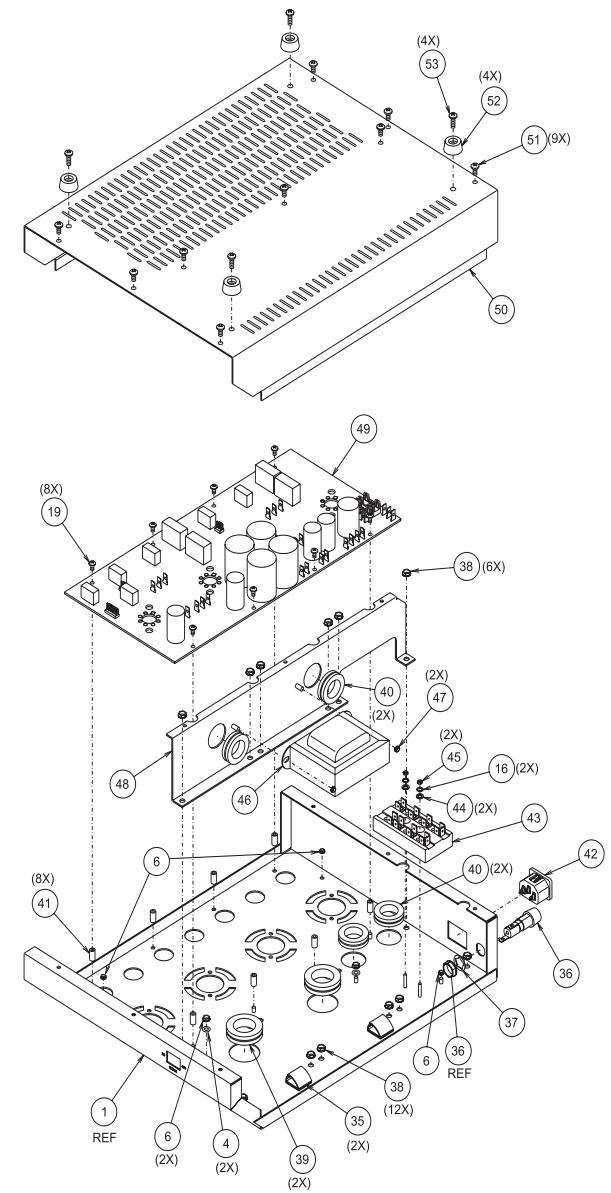
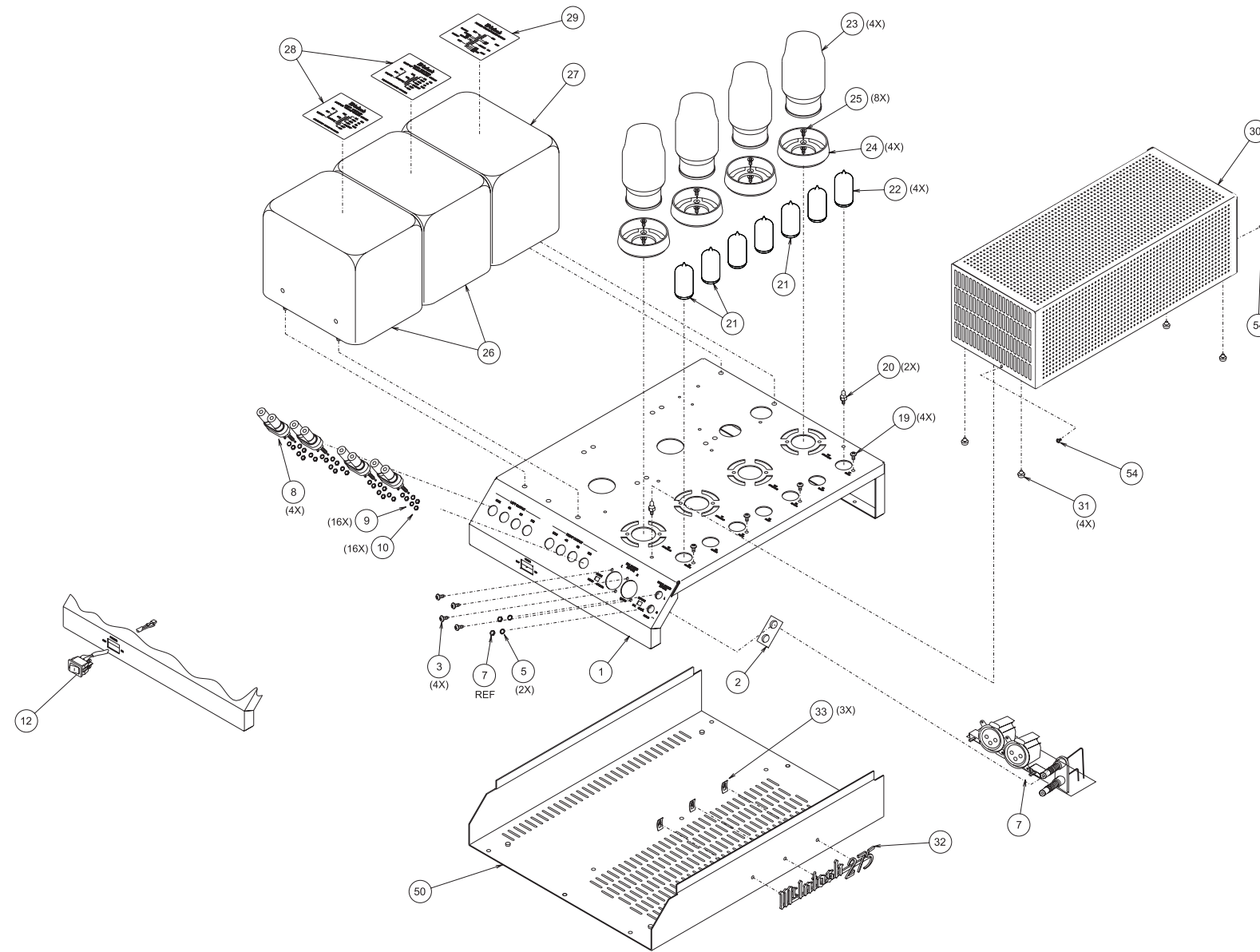

Ref. No. Part No. Description

1	005653	CHASSIS
2	005650	RCA SPACER
3	101197	SCREW HI/LO 4-24 X 3/8 PH RD BLK
4	404007	WASHER LOCK 6 X .288 INT STAR
5	104165	WASHER 3/8 INTERNAL TOOTH GOLD
6	402003	NUT KEP 6-32
7	750082	ASSY INPUT PCB
8	084219	POST BINDING DUAL 4MM THREAD
9	404198	LOCK WASHER
10	410015	NUT M4 INT STAR SS
12	171729	CABLE ASSY POWER SWITCH
13	104165	WASHER 3/8 INT TOOTH GOLD

19	400157	SCREW MACH 6-32 X 1/4 PH PN
20	114012	BALL STUD
21	165065	TUBE 12AX7A McINTOSH
22	165067	TUBE 12AT7
23	165070	TUBE KT88 WITH McINTOSH LOGO
24	017761	AIR PIPE
25	400292	SCREW MACH 6-32 X 3/8 PH FH BLK
26	750085	POTTED TRANSFORMER OUTPUT
27	750086	POTTED TRANSFORMER POWER
28	166126	DECAL OUTPUT TRANSFORMER
29	166127	DECAL POWER TRANSFORMER
30	005651	TUBE COVER

31	017862	PUSH-ON FOOT
32	125667	NAMEPLATE
33	106012	SPRING CLIP: PUSH-ON
35	017452	KLIP WIRE
36	178161	HOLDER FUSE 5 X 20mm IEC
37	404016	WASHER INT STAR .5 X .630 X .022
38	102006	NUT MACH 10-32 W/LOCK
39	078024	GROMMET RUBBER 1" ID
40	078025	GROMMET RUBBER 3/4" ID
41	017859	SPACER NYLON 6-32 X 7/16
42	117487	RECEPTACLE AC LINE
43	074091	TERMINAL BLOCK AC

44	404001	WASHER FLAT STEEL 4 X 9/32 X .025
45	402022	NUT MACH 4-40 X 3/16 X 1/16
46	122379	CHOKE FILTER
47	402005	NUT MACH 8-32 W/LOCK
48	005425	SUPPORT BRACKET
49	750675	ASSY AMPLIFIER PCB
50	005426	BOTTOM COVER
51	401078	SCREW TAP 8-32 X 5/16 PH PN BLK
52	017542	PLASTIC FOOT
53	400153	SCREW MACH 8-32 X 1/2 PH PN
54	401109	SCREW TT 6-32 X 5/16 PH PN BLK

REPACKING INSTRUCTIONS

In the event it is necessary to repack the unit for shipment, the unit must be packed exactly as shown below.

IMPORTANT - For ease of shipment, attach the four feet to the bottom of the unit. Failure to do this will result in shipping damage.

If a shipping carton or any of the interior parts is needed, please call or write the Customer Service Department of McIntosh Laboratory. Order parts from the accompanying list by part number.

Use the original shipping carton and interior parts only if they are in good serviceable condition.

Qty.	Part No.	Description
1	033704	Bottom pad
1	033705	Front Pad
1	033706	Rear Pad
1	033707	Top pad
2	033711	Side pad
1	033712	Foam pad (tube cover)
2	033718	Foam endcaps
1	034005	Shipping carton (outside)
1	034006	Shipping carton (inside)
2	034265	Tube pack
2	034266	Tube pack (end)

MC275

STEREO POWER AMPLIFIER

STARTING WITH SERIAL NO. WV1536

SERVICE MANUAL

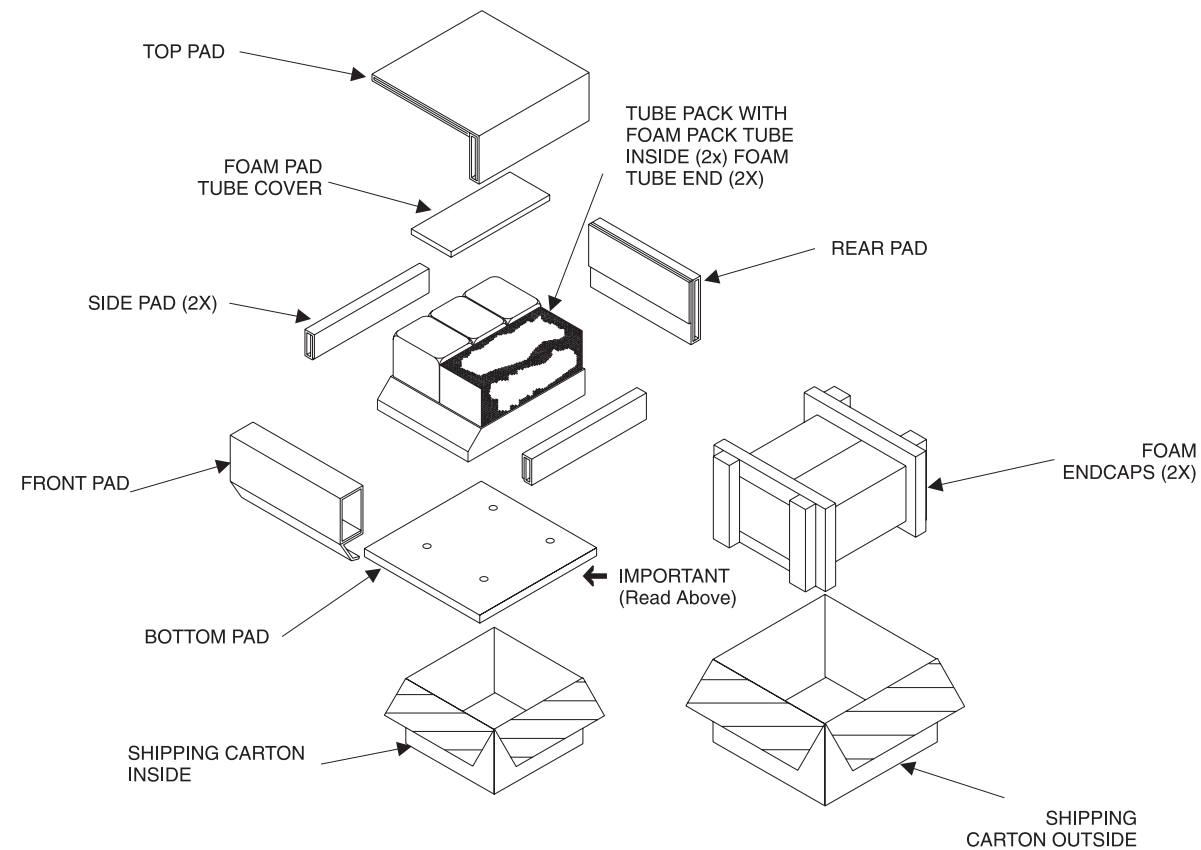

The continuous improvement of its products is the policy of McIntosh Laboratory Incorporated, who reserve the right to improve design without notice. Because of the constant upgrading of McIntosh products' circuitry and components, the Company cannot insure, and does not warrant, the accuracy of the within schematic material, which is intended for information only.