

MC500

POWER AMPLIFIER

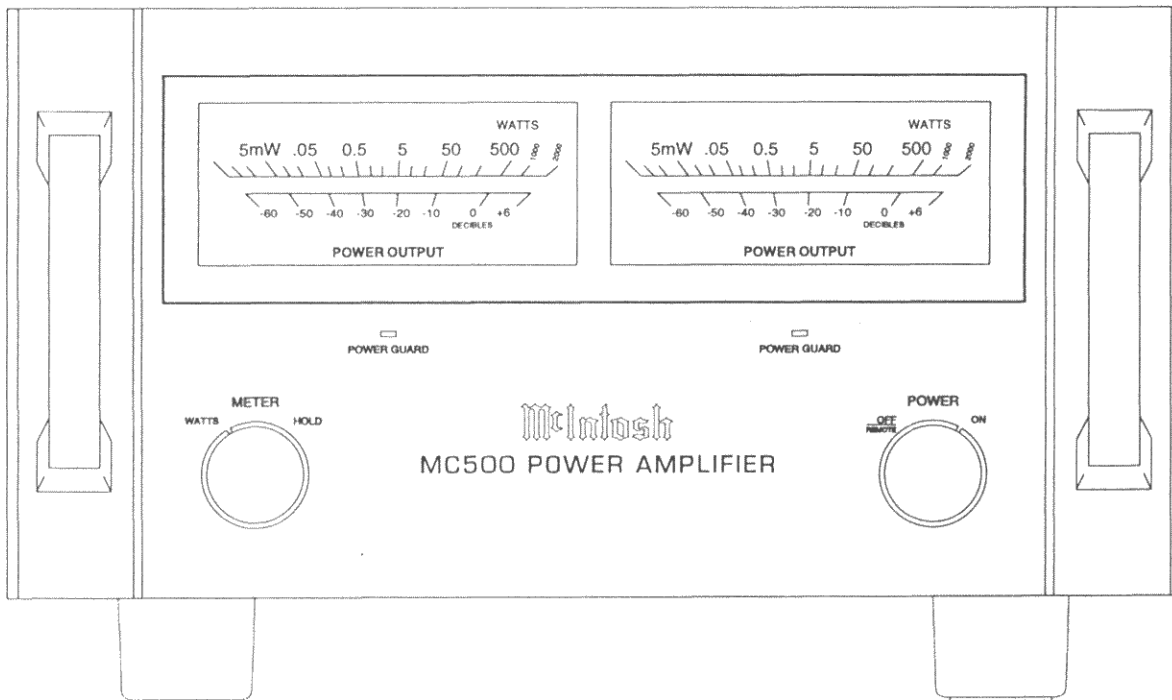

CONTENTS

Performance Specifications	3
Rear Panel	4
Notes	4
Section Locations	5
Block Diagram	6-7
① Interconnection Diagram	8-10
① Front Panel and Trim Parts List	10
② Power Driver, Left and Right	11-13
③ Meter Regulator	14-19
④ Distribution	20-22
⑤ Heatsink	23-24
⑥ Relay and Power Control	25-26
Repacking Instructions	27

McIntosh

Service Manual

Performance Specifications

POWER OUTPUT

500 watts per channel into 8, 4 or 2 ohm load is the minimum sine wave continuous average power output.

1000 watts Mono into a 16, 8 or 4 ohm load is the minimum sine wave continuous average power output.

RATED POWER BAND

20Hz to 20,000Hz

TOTAL HARMONIC DISTORTION

0.005% maximum harmonic distortion at any power level from 250 milliwatts to rated power output.

DYNAMIC HEADROOM

2.1dB

FREQUENCY RESPONSE

+0, -0.25dB from 20Hz to 20,000Hz

+0, -3.0dB from 10Hz to 100,000Hz

INPUT SENSITIVITY

2.2 volts, Stereo Balanced and Unbalanced.

2.2 volts, BRIDGED (Mono) Balanced.

3.2 volts, BRIDGED (Mono) Unbalanced.

A-WEIGHTED SIGNAL-TO-NOISE RATIO

85dB (115dB below rated output).

INTERMODULATION DISTORTION, SMPTE

0.005% maximum if instantaneous peak power output does not exceed twice the output rating.

WIDE BAND DAMPING FACTOR

200 at 8 ohm output

INPUT IMPEDANCE

10,000 ohms

POWER GUARD

Clipping is prevented and THD does not exceed 2% with up to 14dB overdrive at 1000Hz.

POWER REQUIREMENTS

120 volts, 50/60Hz, 12 amperes UL/CSA

SIZE

17-1/4 inches (43.8cm) wide, by 10-3/8 inches (26.4cm) high, 20-1/8 inches (51.5cm) deep, including front handles.

WEIGHT

114 pounds (51.7Kg) net; 127 pounds (57.6Kg) shipping.

Rear Panel

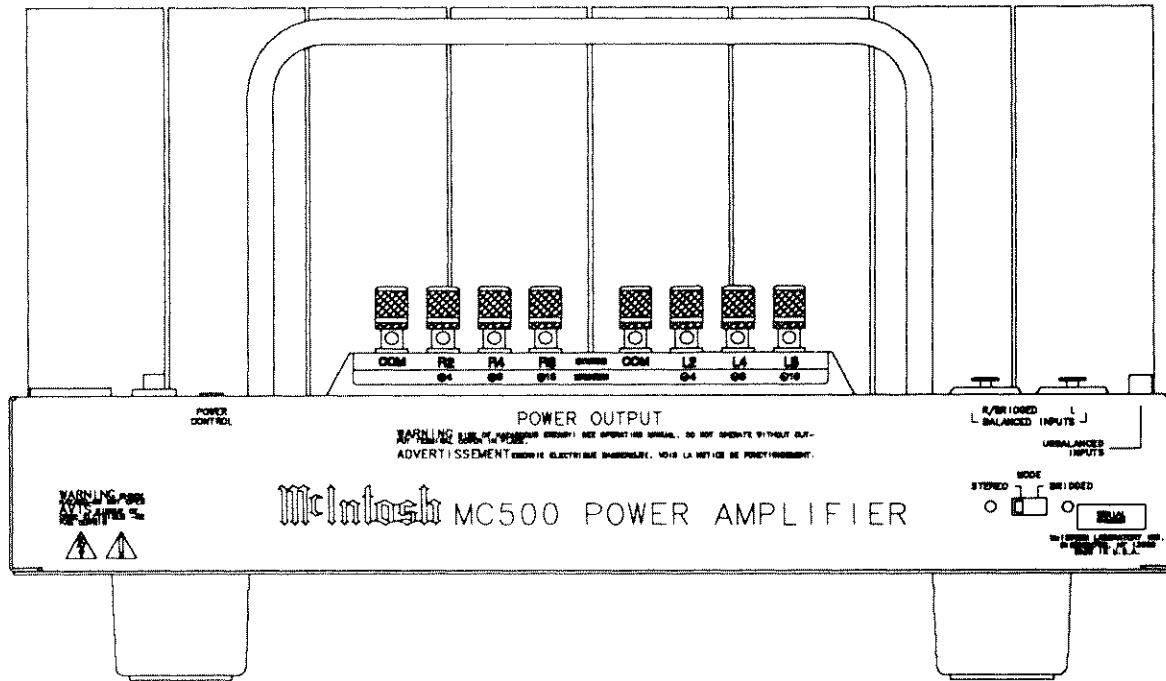



Fig. 1 Rear view

Notes

1. The heavy lines on the schematics denote the primary signal path.
2. Unless otherwise specified:
 - a. Resistor values are in ohms.
 - b. Capacitor values are in microfarads (uF).
 - c. Inductor values are in microhenries (uH).
 - d. All voltages are $\pm 10\%$ with respect to ground. A high impedance (10 megohm) voltmeter must be used.
 - e. Front panel controls are set at:
 METER WATTS
 POWER ON
3. On PC Board Drawing's, Square Pad Indicates:
 - a. Polarized Capacitors - Positive
 - b. Diodes - Cathode
 - c. Others - Pin 1
4. **WARNING:**
 Parts marked with the symbol  have critical characteristics. Use ONLY replacement parts recommended by the manufacturer.

Section Locations

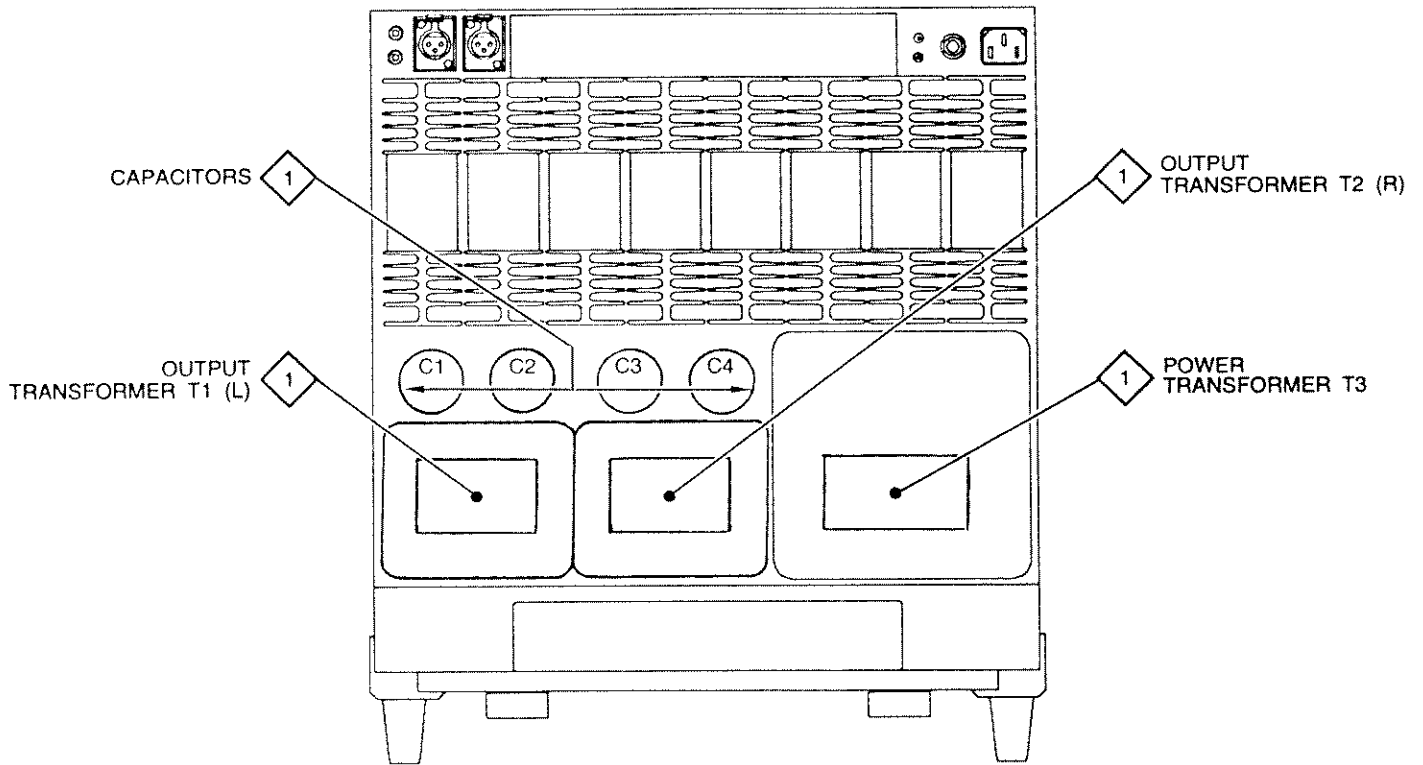

Fig. 2. Top view with cover removed

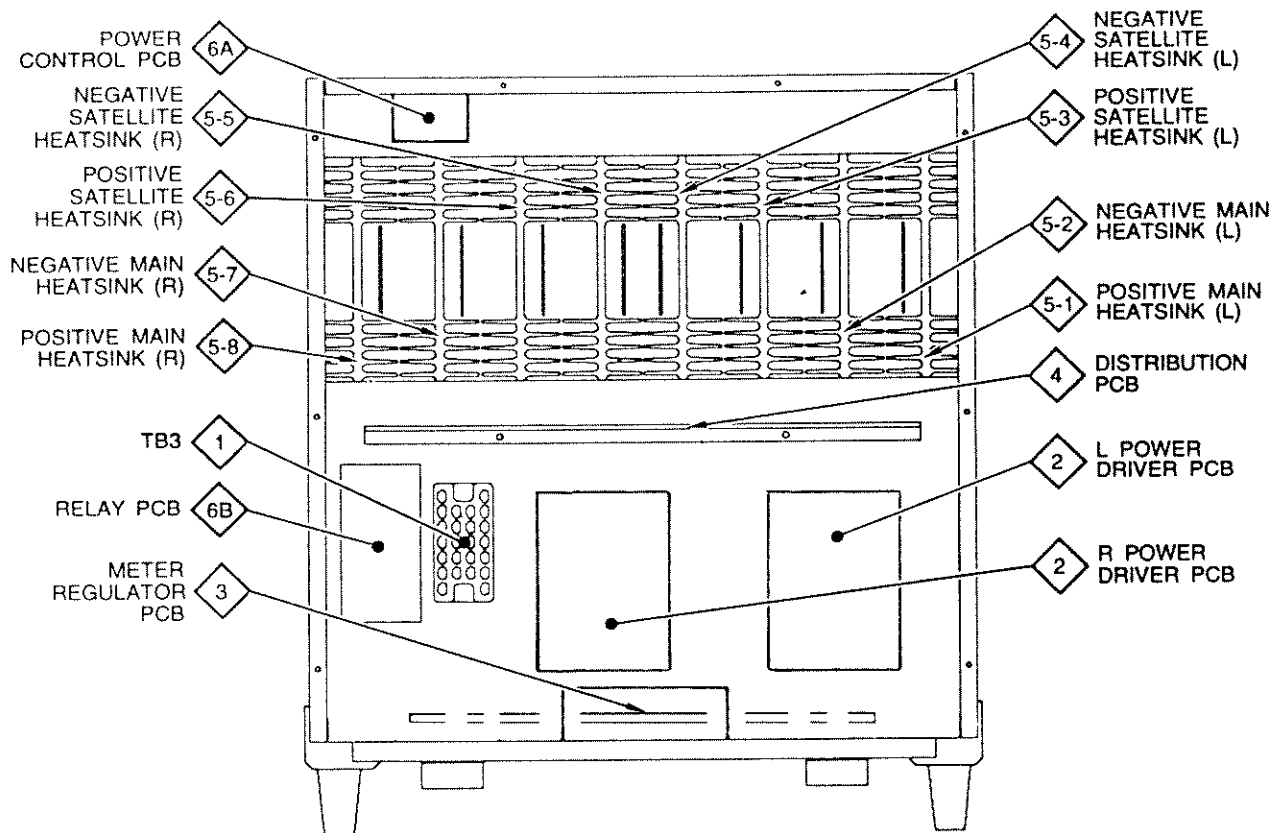
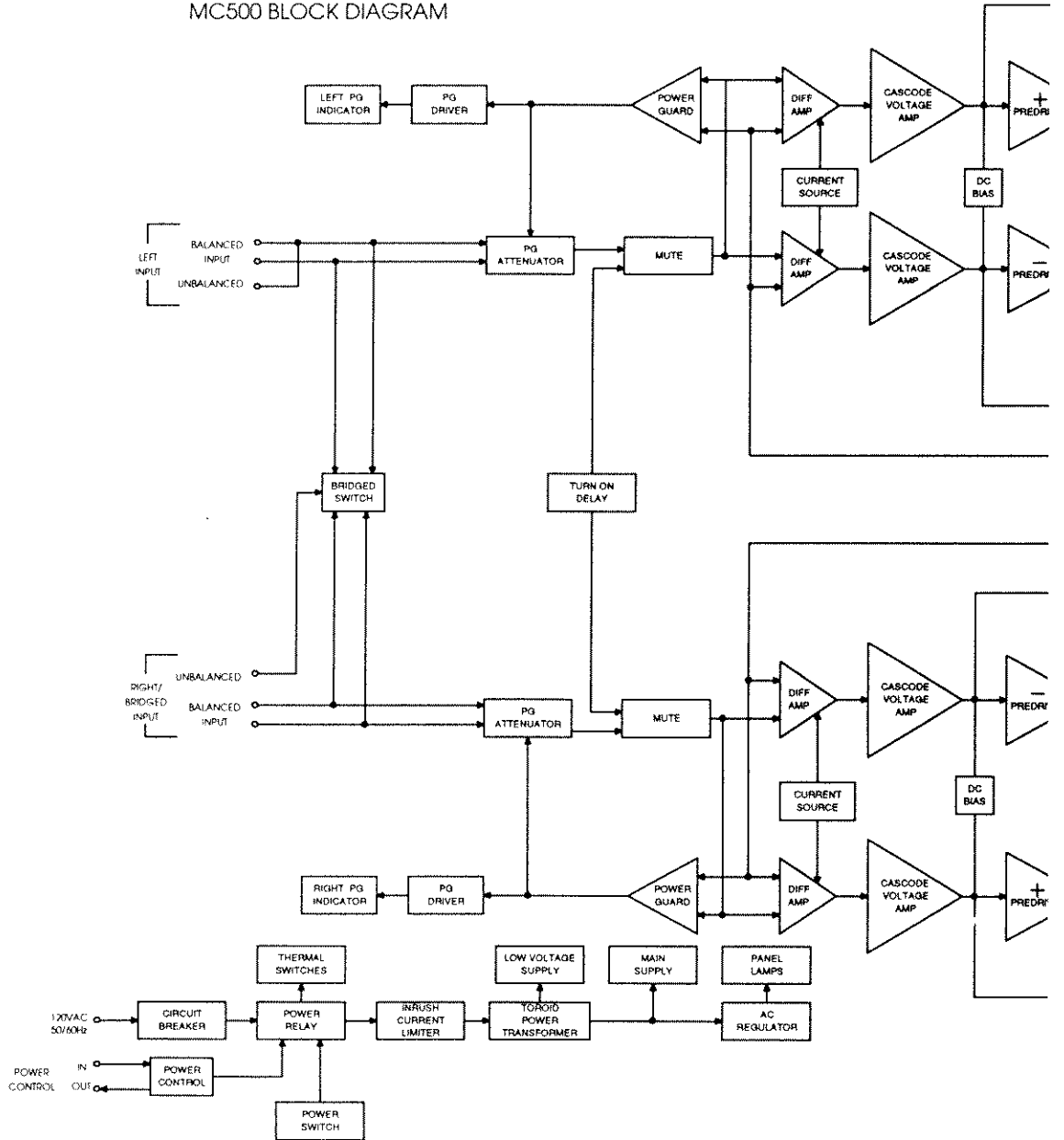
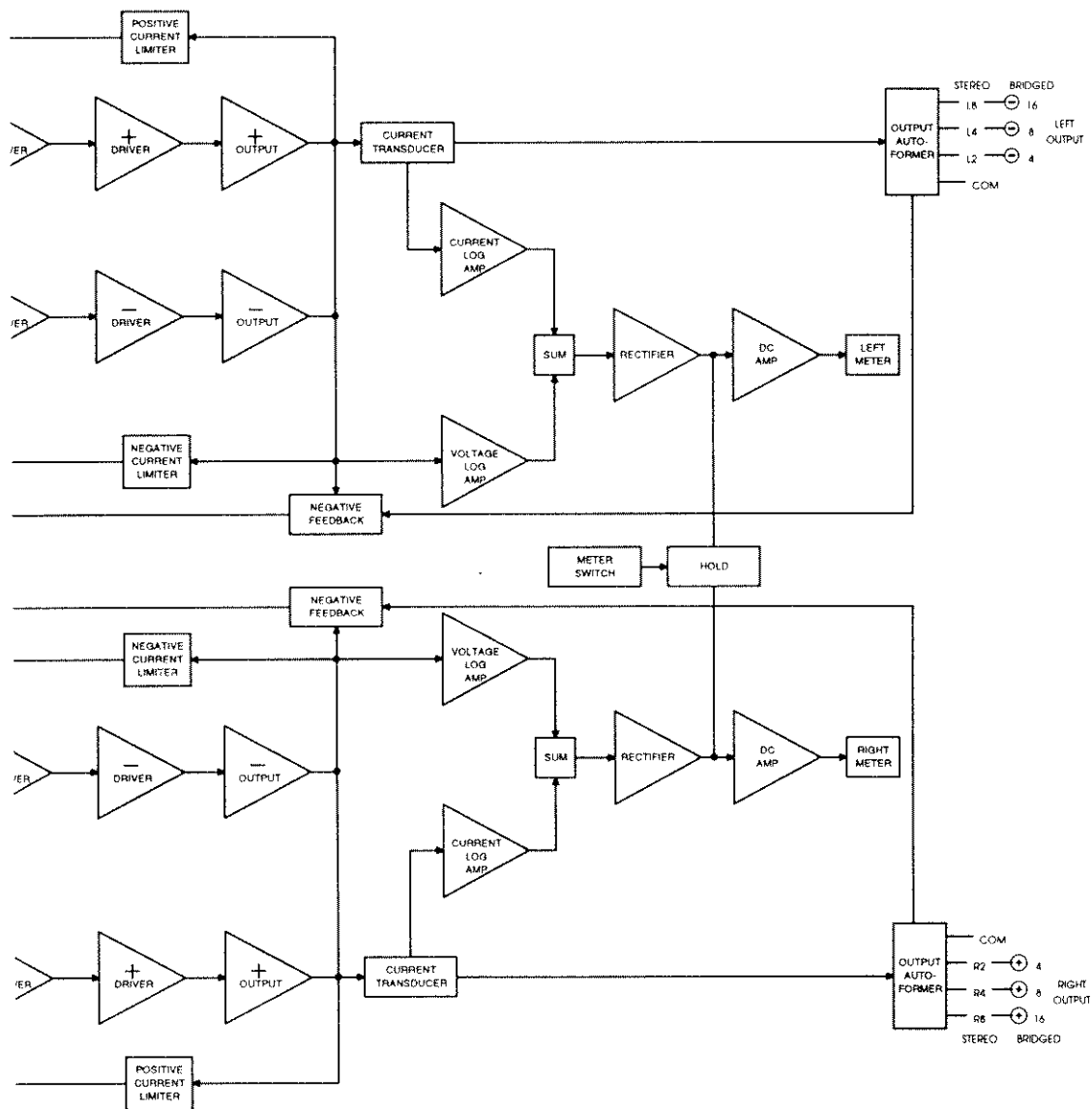

Fig. 3. Bottom view with cover removed

Block Diagram

MC500 BLOCK DIAGRAM





1 Interconnection Diagram

INTERCONNECTION PARTS LIST

Symbol	Part	Description
CAPACITORS		
C1,C4	066449	ELECT, 2200uF, 100V
C7,C8	061276	CD, .0047uF, 400V, UL/CSA
CIRCUIT BREAKERS		
CB1	088016	CB, 20A
DIODES		
D1,D2	070139	BRIDGE, RECT, GBPC3504
METERS		
M1,M2	124055	METER
SWITCHES		
S1,S2	153017	Thermal Switch
S3,S4	146183	Power Switch
S5	148061	Slide Switch, 4PDT
THERMISTORS		
RT1,RT2	144231	Thermistor, 2.5 ohm
TRANSFORMERS		
T1,T2	048116	OUTPUT POWER
T3	048248	POWER

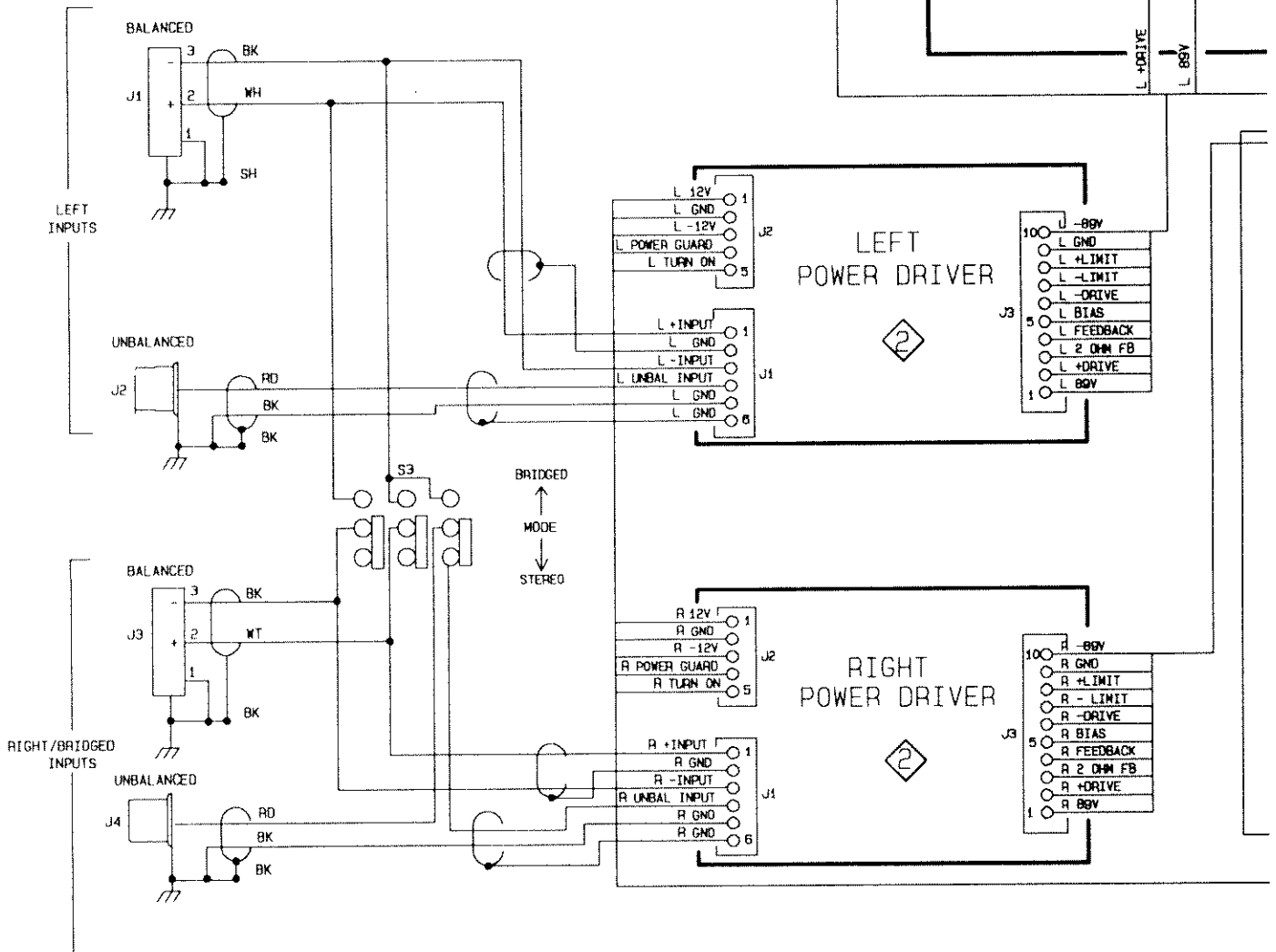
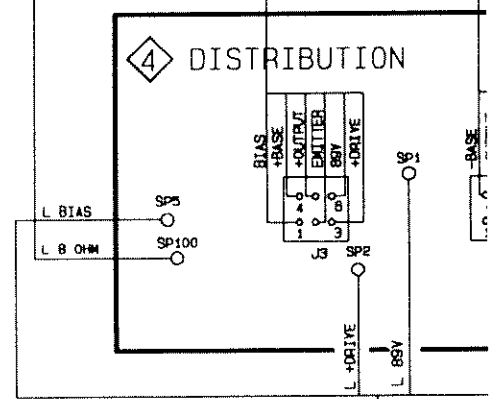
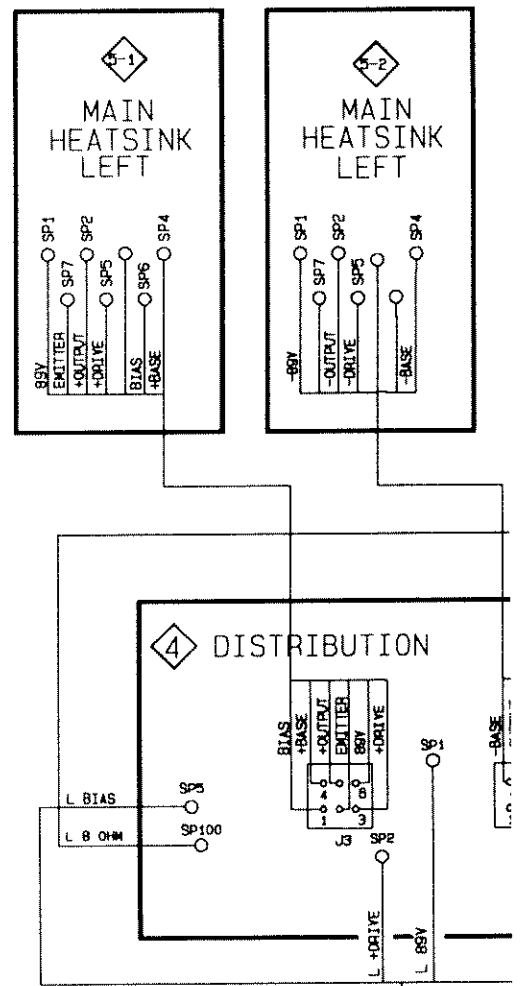

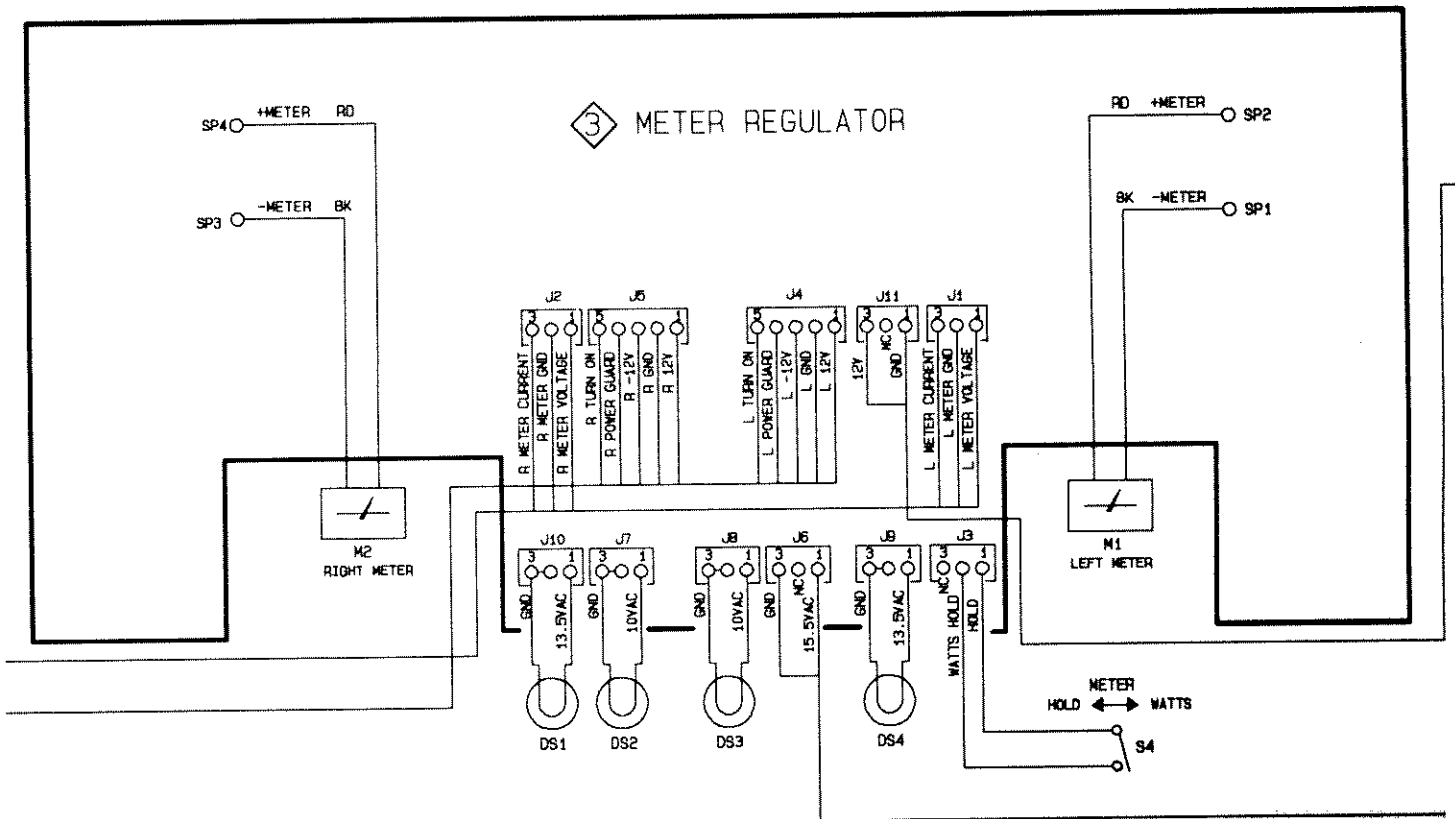
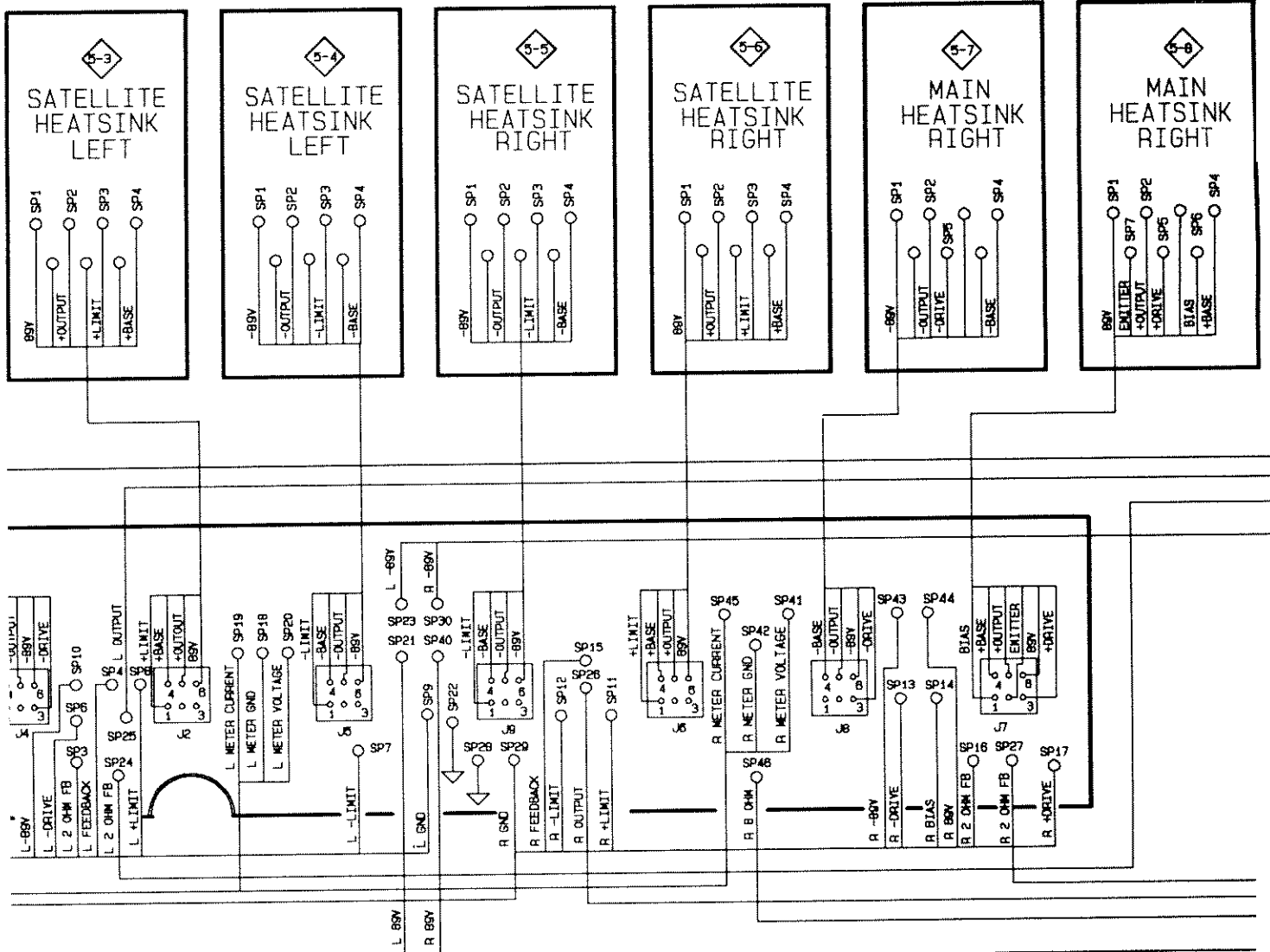

FRONT PANEL and TRIM PARTS LIST

Part	Description
016313	Front Panel, Glass
018386	Handle
047474	Knob

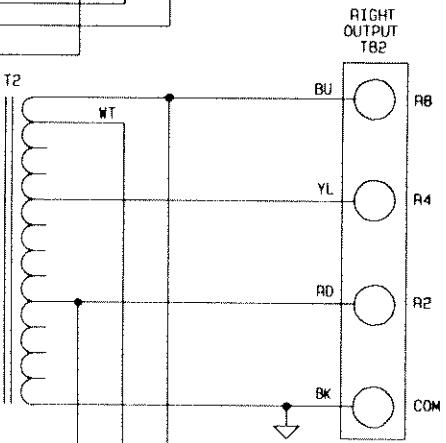
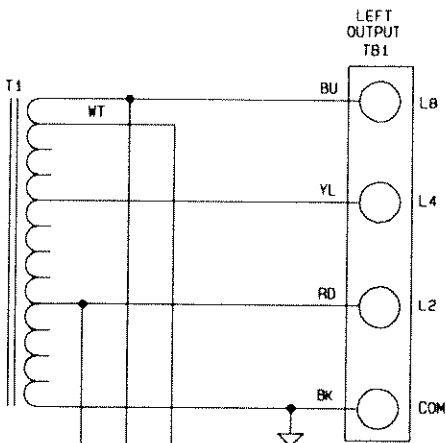

WARNING: Parts located in this shaded area have critical characteristics. Use ONLY replacement parts recommended by the manufacturer.

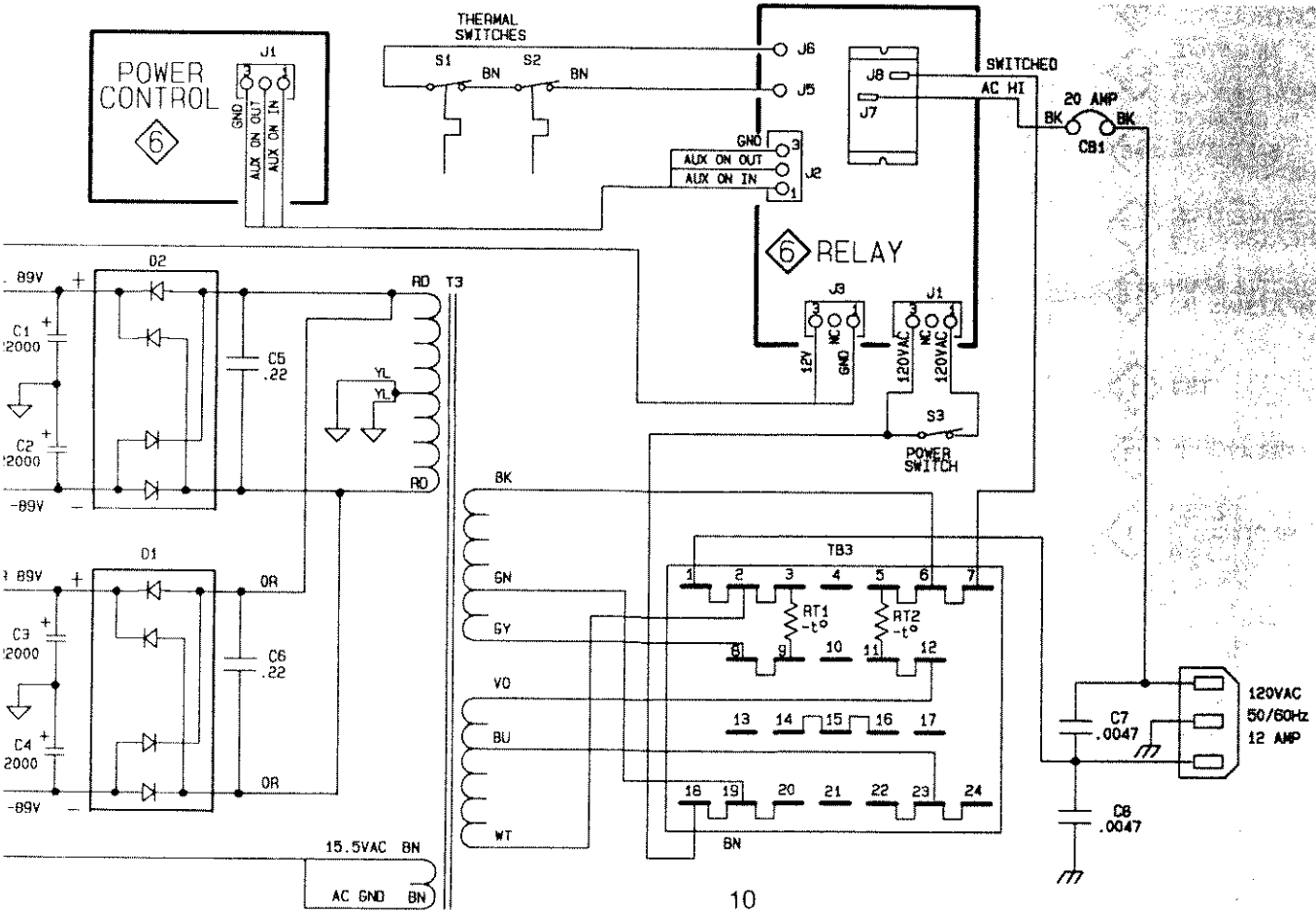

Power Driver, Left and Right

2

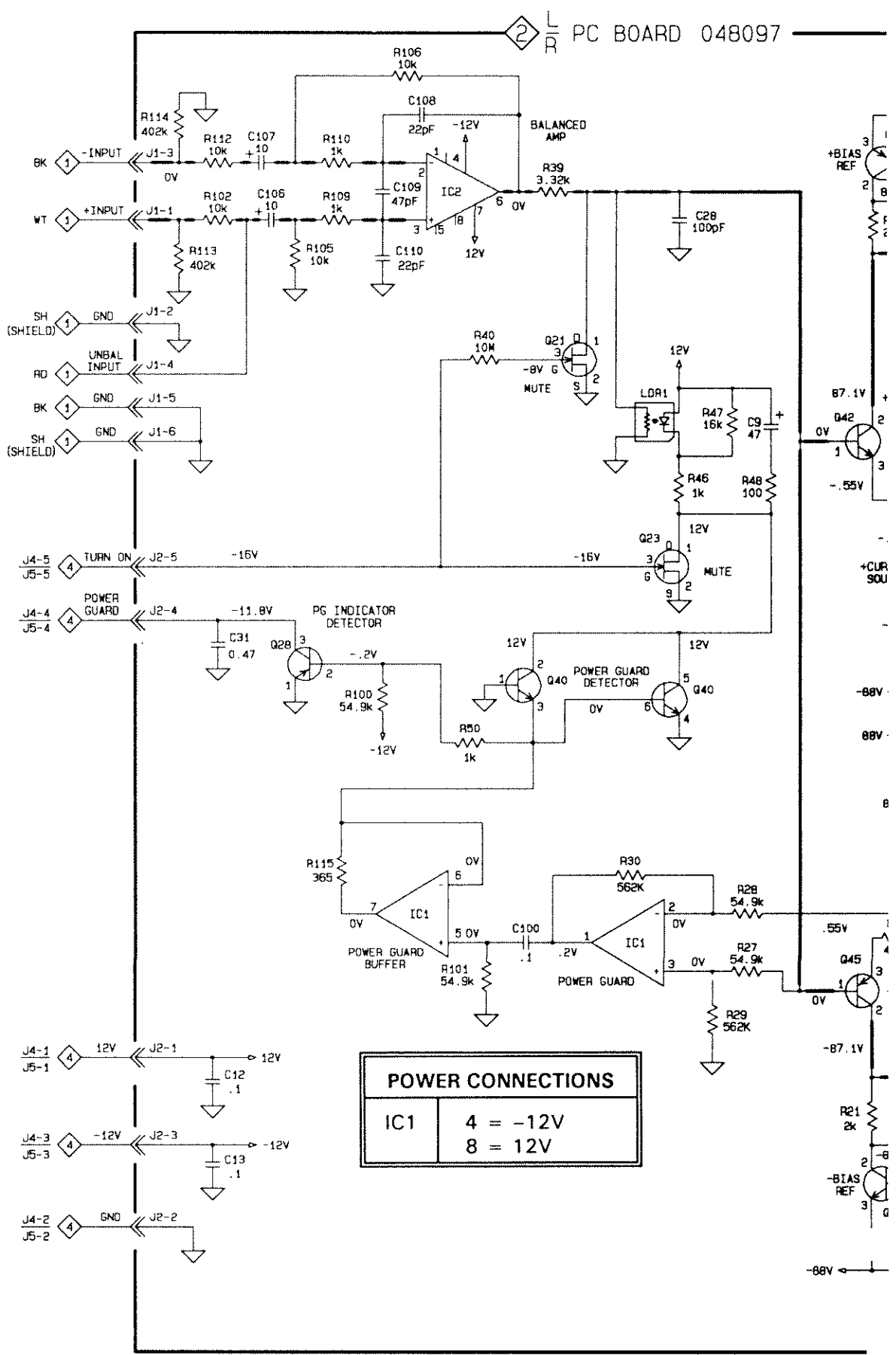

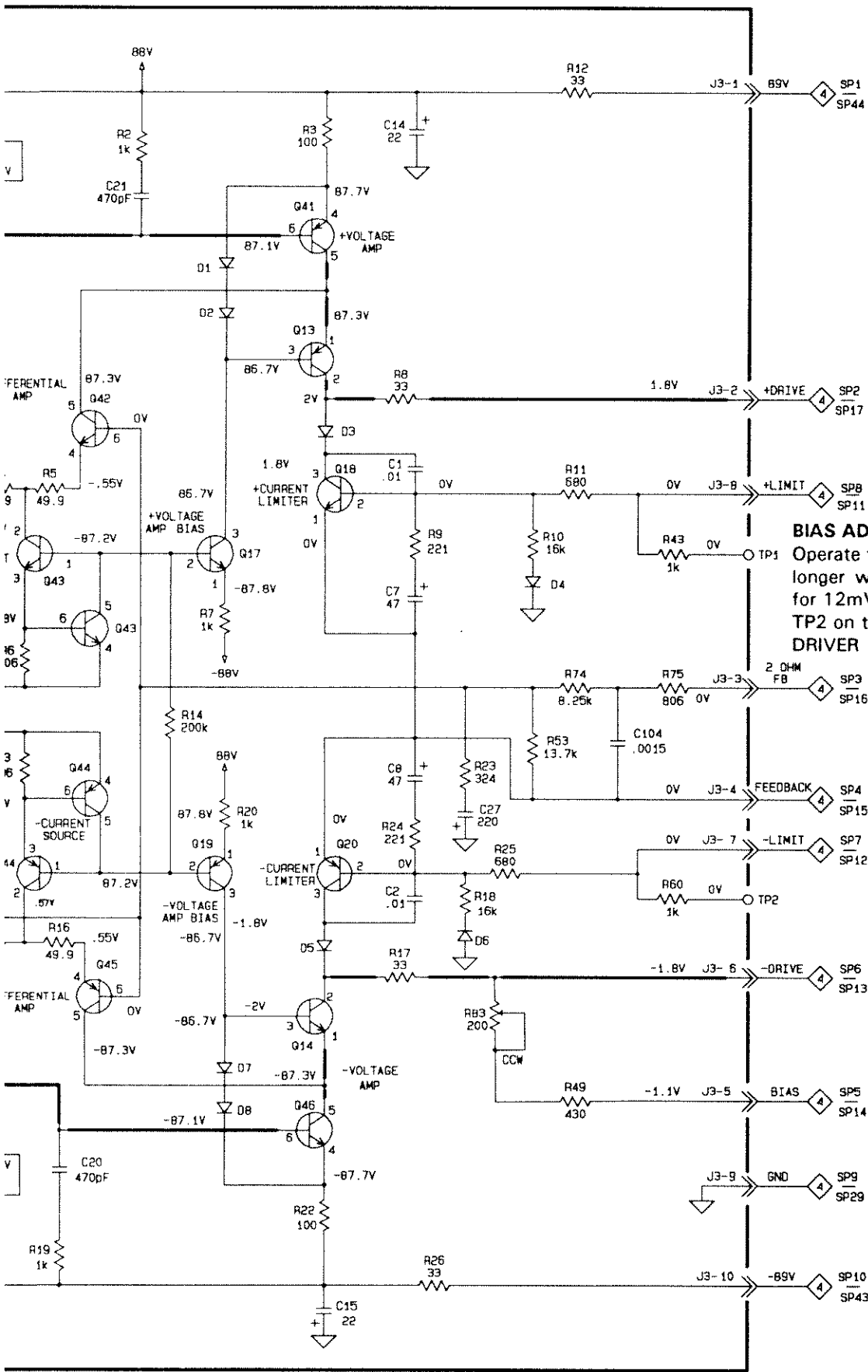

BIAS ADJUSTMENT
 Operate the amplifier for 2 minutes or longer with no output. Adjust R83 for 12mV ± 2mV DC across TP1 and TP2 on the LEFT and RIGHT POWER DRIVER PC Board.

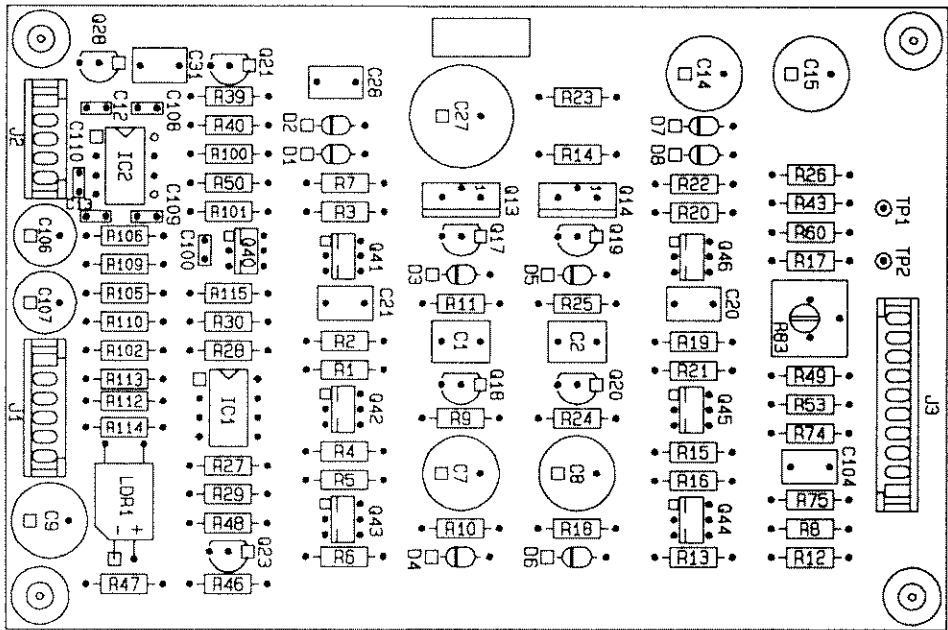

**POWER DRIVER PCB 048097
LEFT AND RIGHT**

**POWER DRIVER(S)
LEFT and RIGHT
PARTS LIST**

Symbol	Part	Description
DIODES		
D1-D8	070047	SIG, 75V, 150mA, 1N4148
INTEGRATED CIRCUITS		
IC1	133028	Dual Hi-Speed Operational Amp, MC4558CP1
IC2	133066	Operational Amp, NE5534N
LIGHT DEPENDENT RESISTORS		
LDR1	144179	LDR, VTL5C9
TRANSISTORS		
Q13	132249	PNP, 2SA1480D or 2SA1480C
Q14	132248	NPN, 2SC3790D or 2SC3790E
Q17	132136	NPN, MPSA42
Q18	132171	NPN, MPSA05
Q19	132147	PNP, MPSA92
Q20	132172	PNP, MPSA55
Q21	132222	N, FET, J108
Q23	132193	N, JFET, 2N4392
Q40	132252	NPN, Dual, 2SC3064G
Q41	132253	PNP, Dual, 2SA1237G
Q42,Q43	132250	NPN, Dual 2SC3066G
Q44,Q45	132251	PNP, Dual, 2SA1239G
Q46	132252	NPN, Dual, 2SC3064G

3 Meter Regulator

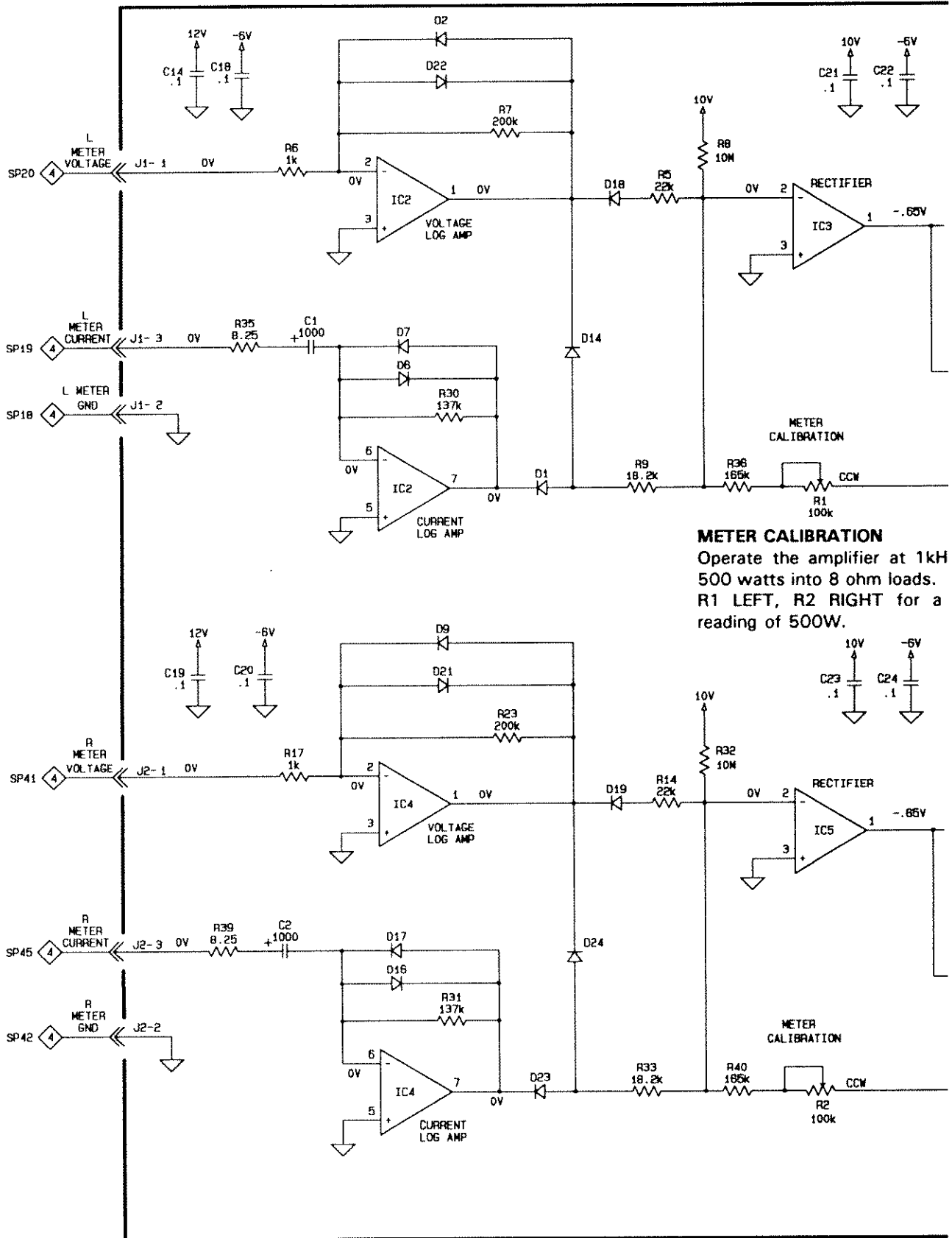

METER CALIBRATION
 Operate the amplifier at 1kH
 500 watts into 8 ohm loads.
 R1 LEFT, R2 RIGHT for a
 reading of 500W.

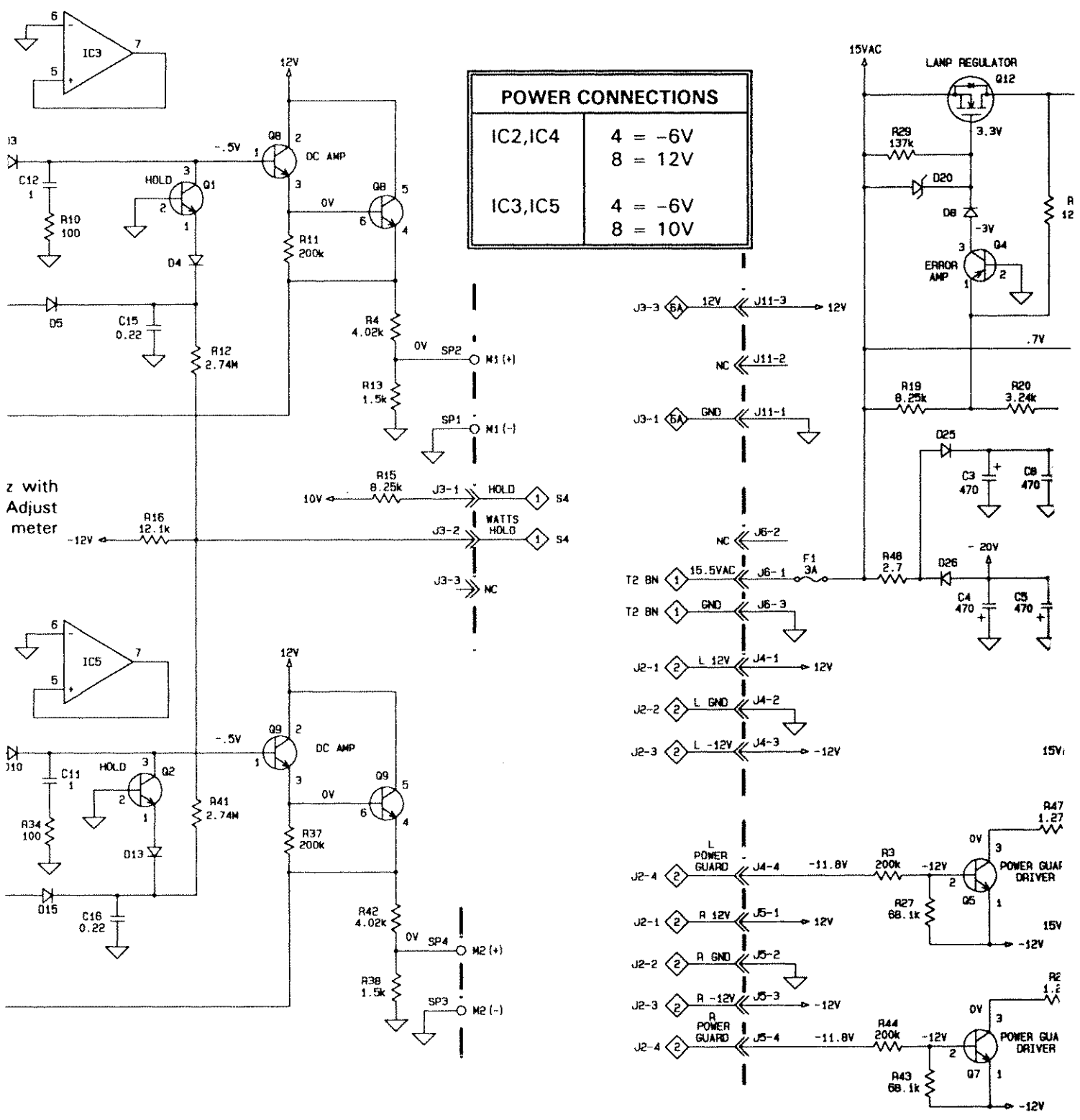

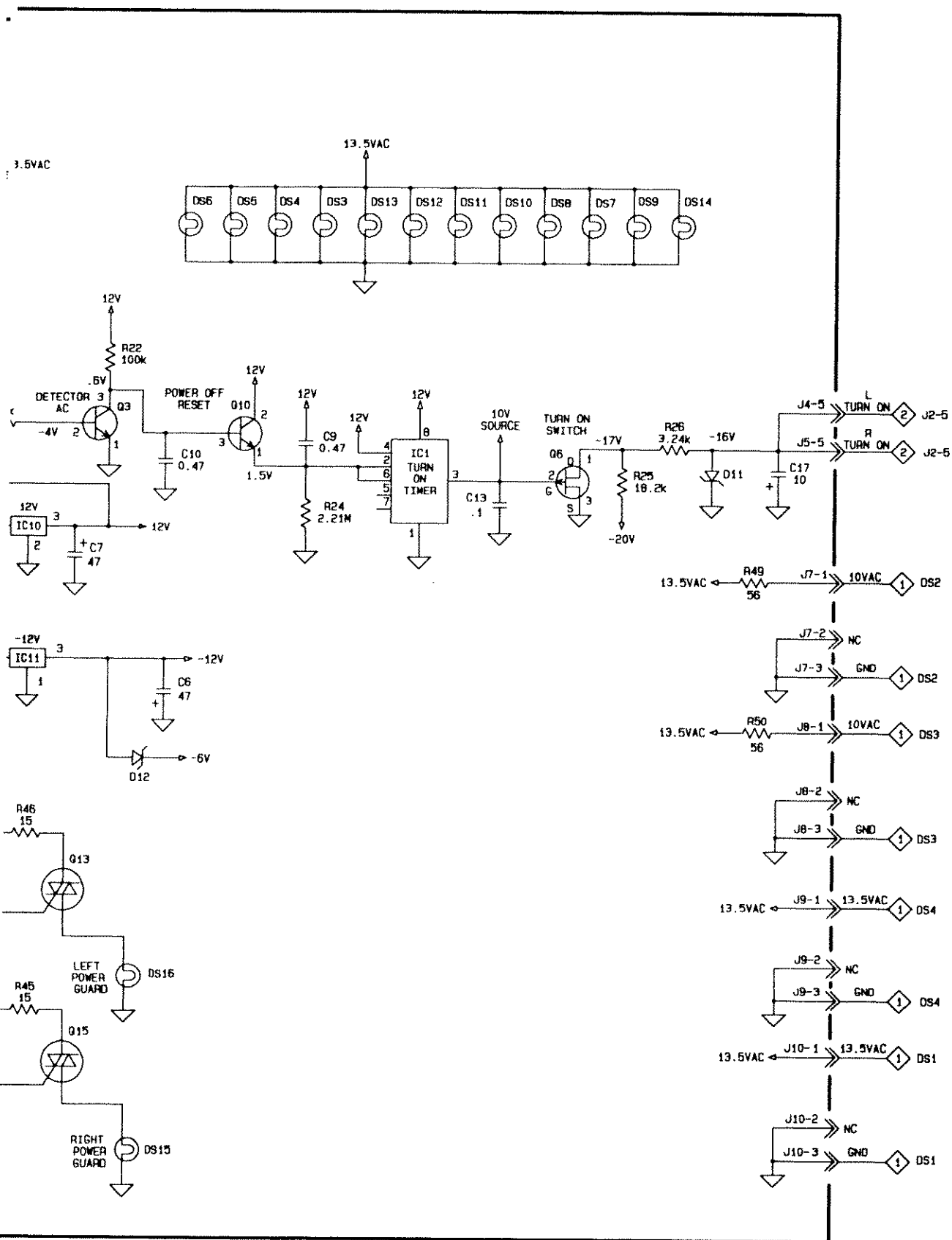

METER REGULATOR PARTS LIST

<i>Symbol</i>	<i>Part</i>	<i>Description</i>
DIODES		
D1,D2	070047	SIG, 75V, 150mA, 1N4148
D3	070136	SIG, Low Leakage, FDH300
D4-D9	070047	SIG, 75V, 150mA, 1N4148
D10	070136	SIG, Low Leakage, FDH300
D11	070114	ZN, 16V, 5% 500mW
D12	070085	ZN, 6.2V, 5%, 500mW, 1N5234B
D13-D19	070136	SIG, Low Leakage, FDH300
D20	070099	ZN, 12V, 5%, 500mW, 1N5242B
D21-D24	070136	SIG, Low Leakage, FDH300
D25,D26	070131	RECT, 400V, 1A, 1N4004
FUSES		
F1	089066	Fuse, SB, 3A, 250V
INTEGRATED CIRCUITS		
IC1	133141	Timer, NE555N
IC2,IC4	133189	Dual Op-Amp, MC33178P
IC3,IC5	133094	Dual Operational Amp, NE5532N
IC10	133156	+12V Regulator, MC78M12CT
IC11	133155	-12V Regulator, MC79M12CT
LIGHTING DEVICES		
DS3-DS14	058120	INC, 14V, 7373
TRANSISTORS		
Q1-Q3	132223	NPN, MPS4124
Q4	132224	PNP, MPS4126
Q5	132090	NPN, DAR, MPSA25
Q6	132226	P, JFET, J174
Q7	132090	NPN, DAR, MPSA25
Q8,Q9	132252	NPN, Dual, 2SC3064G
Q10	132257	NPN, 2SC3792
Q12	132242	N, FET, BUZ71A
Q13,Q15	131018	Triac, 2N6070A

ASTERISKED (*) COMPONENTS
LOCATED ON THE REVERSE OR
BACKSIDE OF THE BOARD

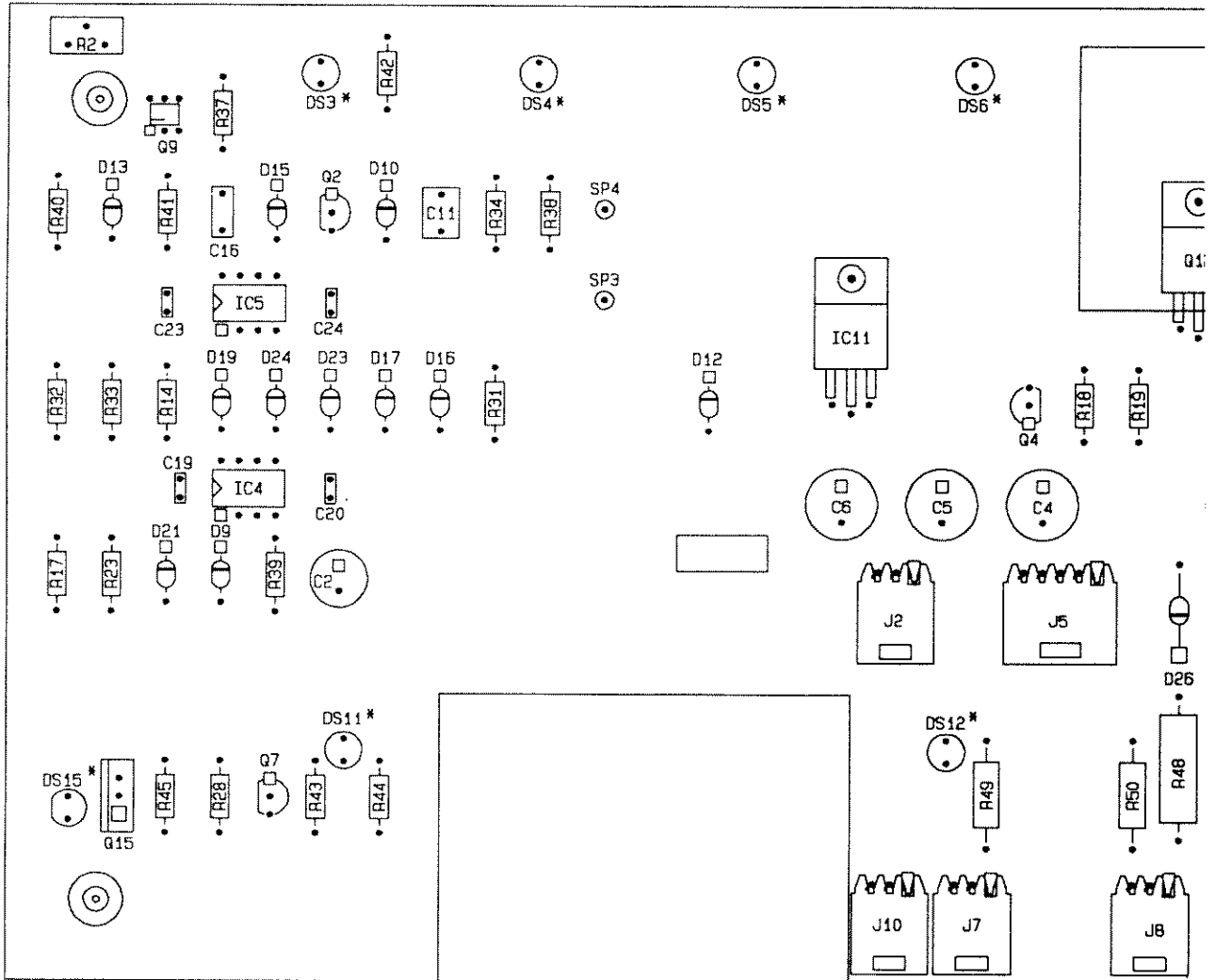

METER REGULAT

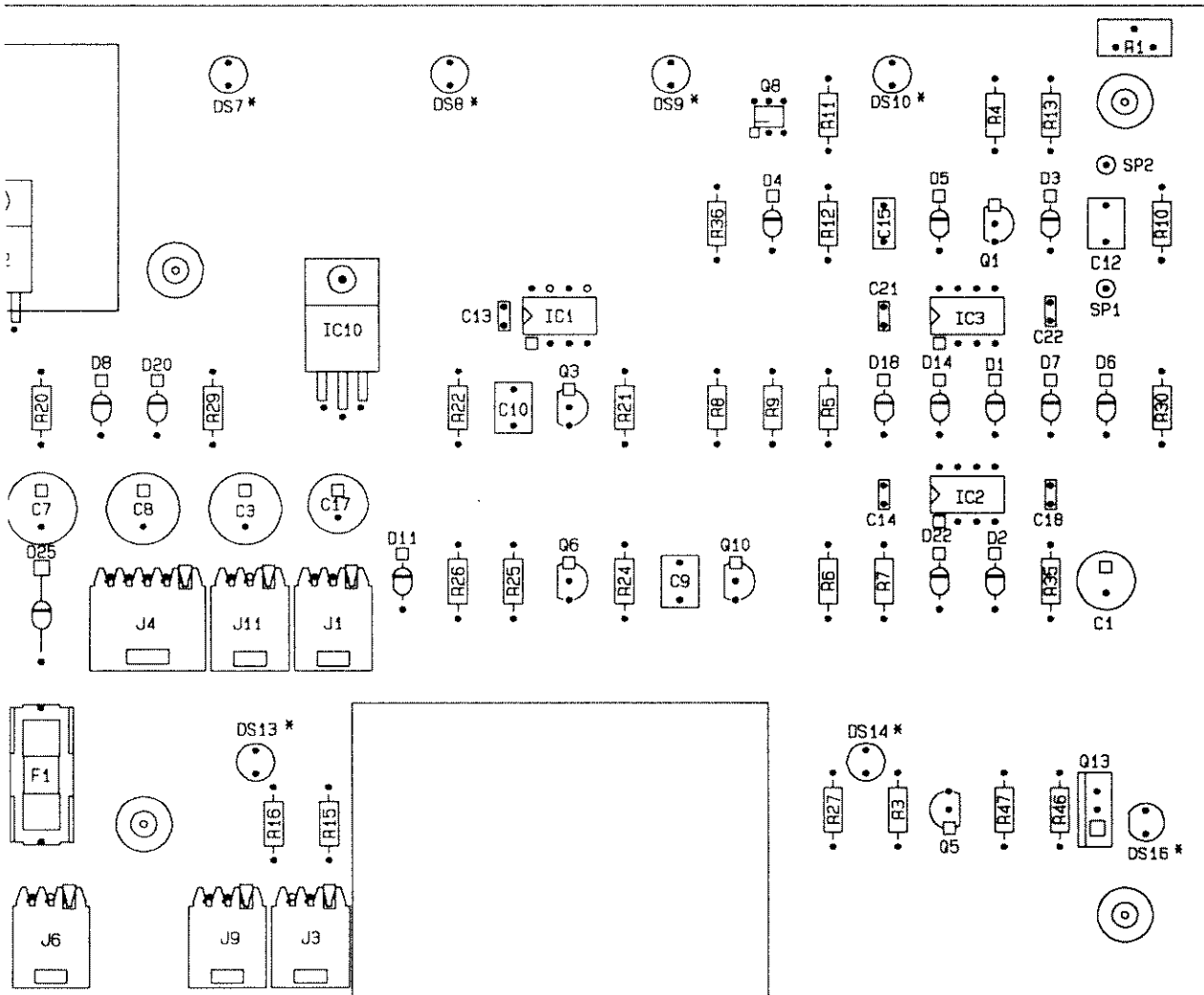

OR PCB 048107

4 Distribution

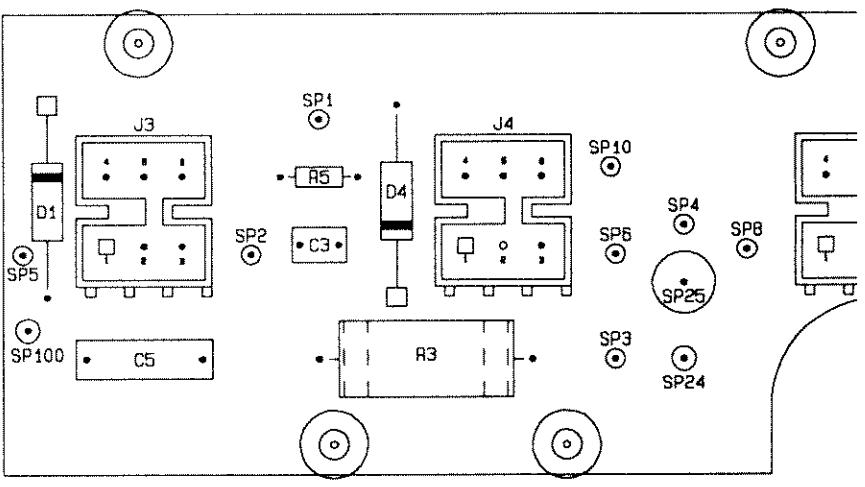
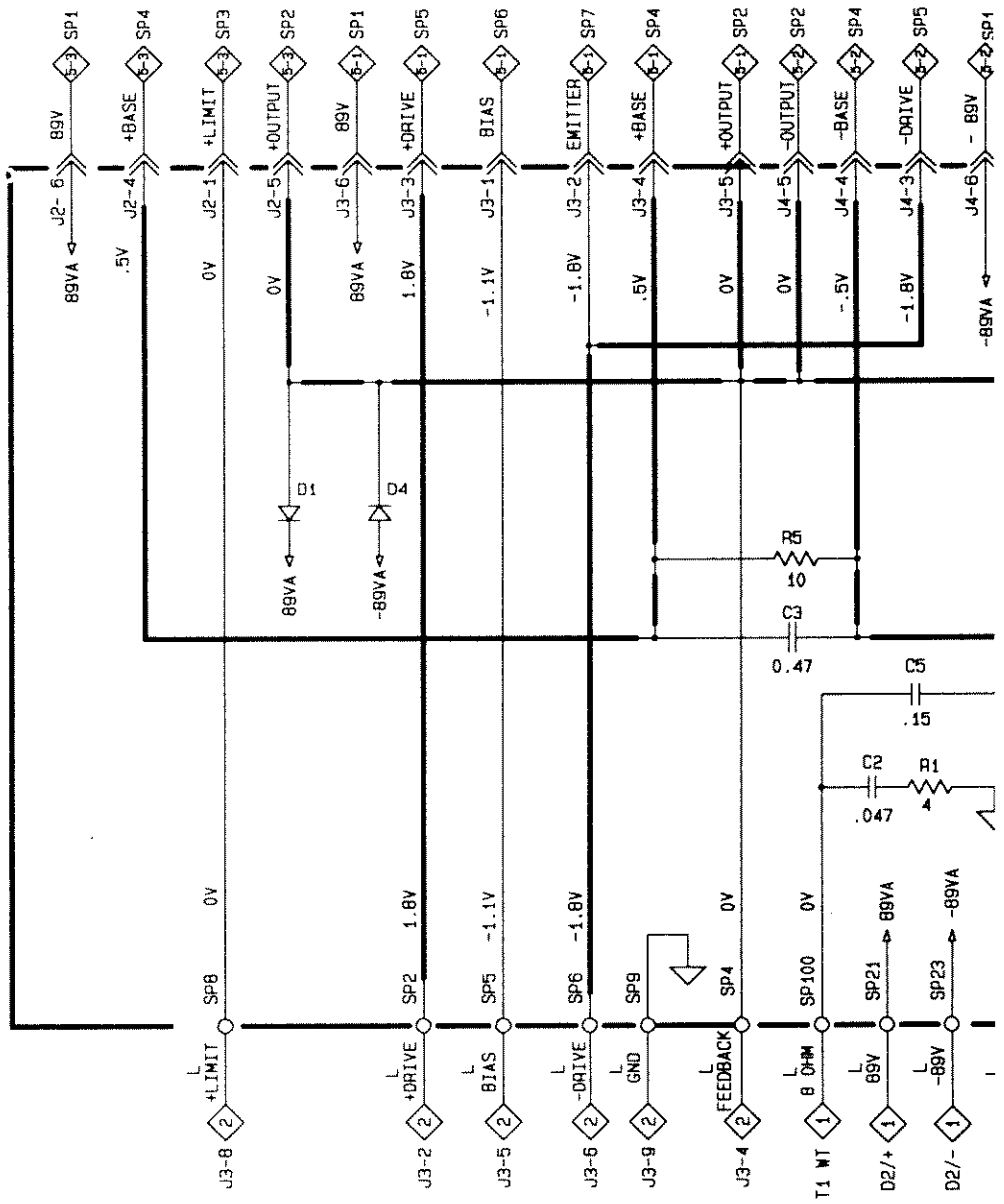

4

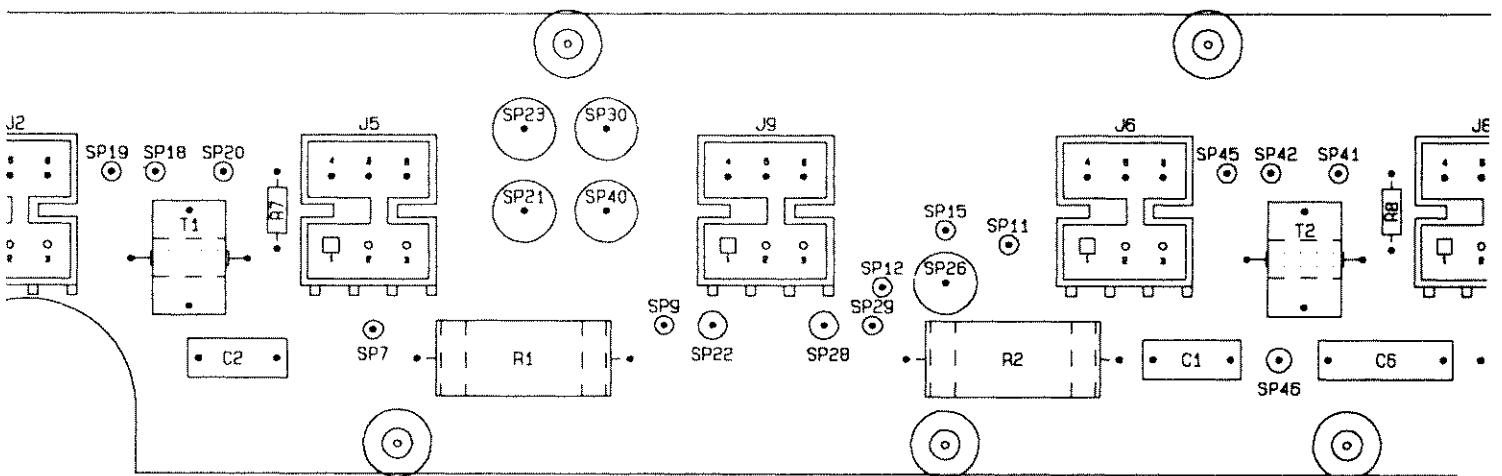
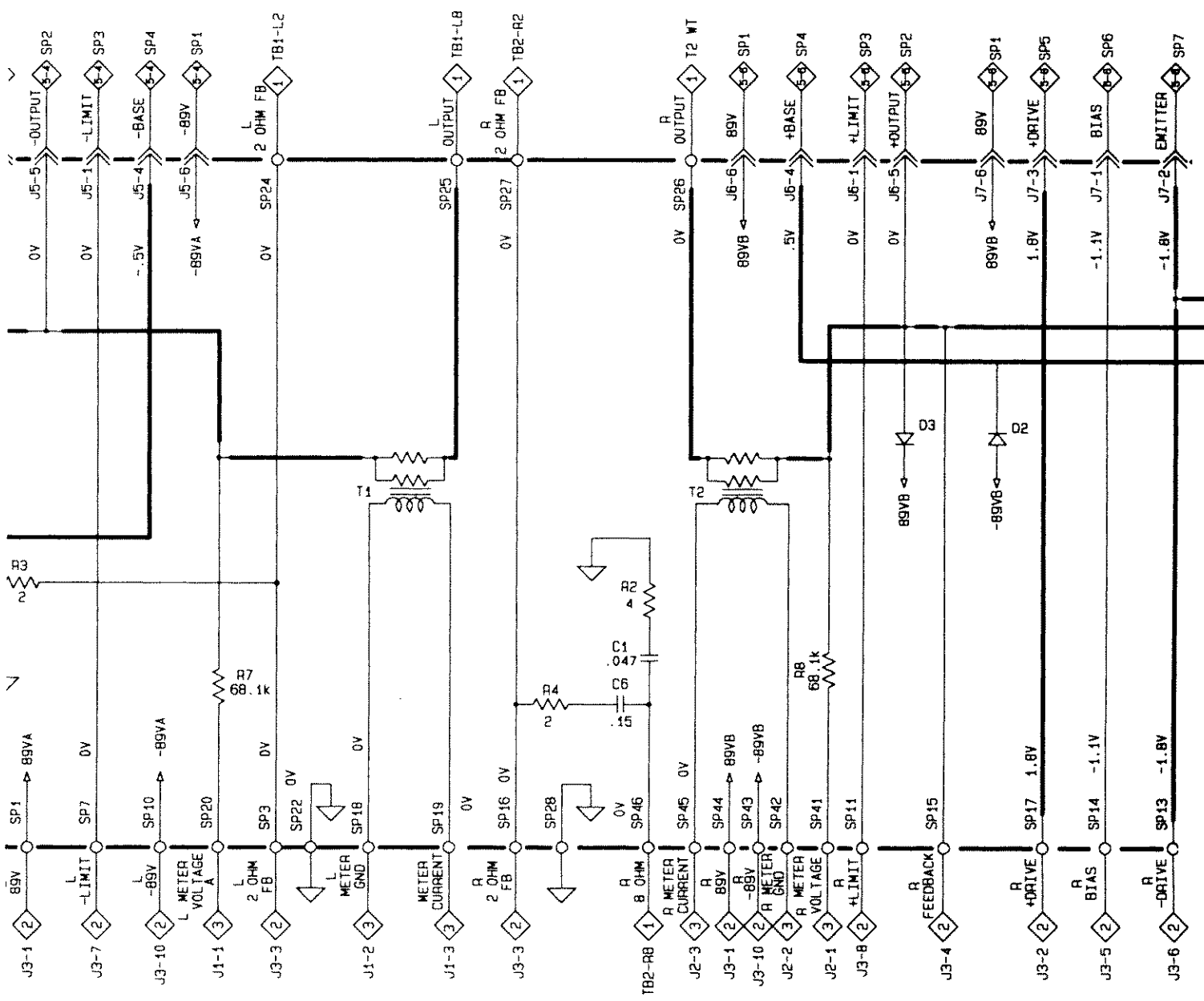

DISTRIBUTION PCB 048134

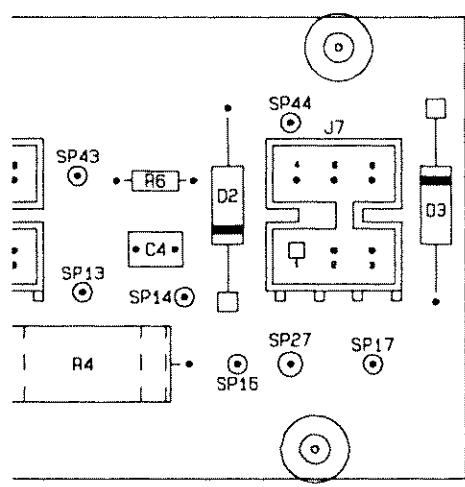
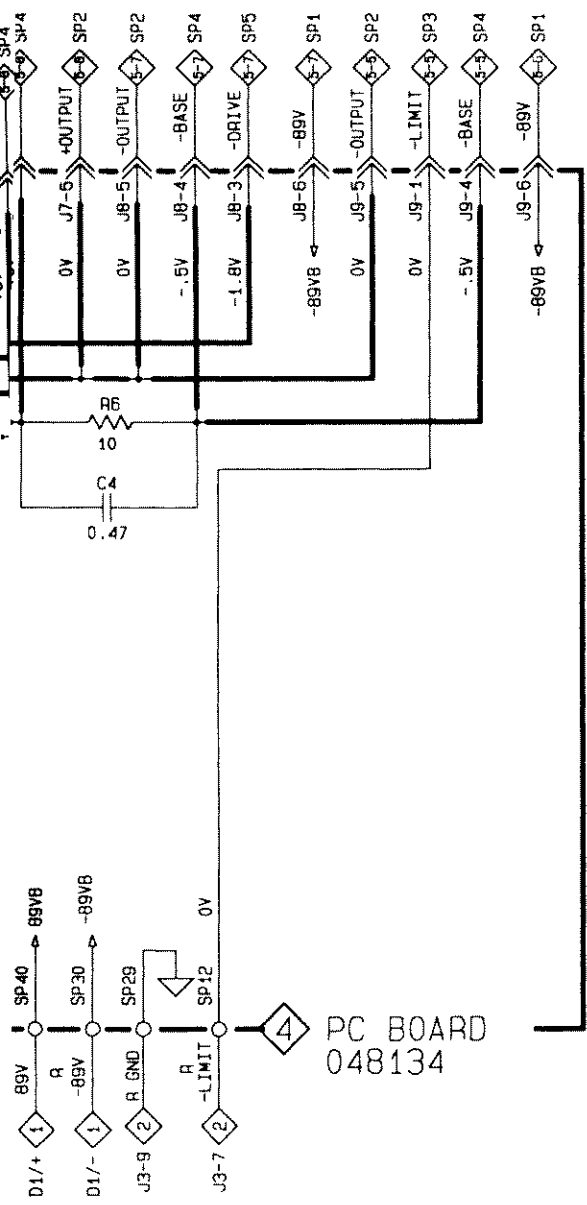

DISTRIBUTION PARTS LIST

Symbol	Part	Description
DIODES		
D1-D4	070126	REC, 200V, 3A
RESISTORS		
R1,R2	139119	WW, 2 ohm, 10%, 5W
R3,R4	139005	WW, 4 ohm, 5%, 5W
TRANSFORMERS		
T1,T2	159215	Current

**HEATSINK NO. 047461
PARTS LIST**

Symbol	Part	Description
TRANSISTORS		
Q1, Q2	132248	NPN, 2SC3790D or E
Q3	132246	NPN, MJ15020
Q4-Q8	132212	NPN

Symbol	Part	Description
RESISTORS		
R3-R7	139185	WW, .5 ohm, 5%, 3W

**HEATSINK NO. 047462
PARTS LIST**

Symbol	Part	Description
TRANSISTORS		
Q2	132249	PNP, 2SA1480D or E
Q3	132247	PNP, MJ15021
Q4-Q8	132213	PNP

Symbol	Part	Description
RESISTORS		
R3-R7	139185	WW, .5 ohm, 5%, 3W

**HEATSINK NO. 047463
PARTS LIST**

Symbol	Part	Description
TRANSISTORS		
Q4-Q8	132212	NPN

Symbol	Part	Description
RESISTORS		
R3-R7	139185	WW, .5 ohm, 5%, 3W

**HEATSINK NO. 047763
PARTS LIST**

Symbol	Part	Description
TRANSISTORS		
Q4-Q8	132213	PNP

Symbol	Part	Description
RESISTORS		
R3-R7	139185	WW, .5 ohm, 5%, 3W

ASTERISKED (*) COMPONENTS
LOCATED ON THE REVERSE OR
BACKSIDE OF THE BOARD

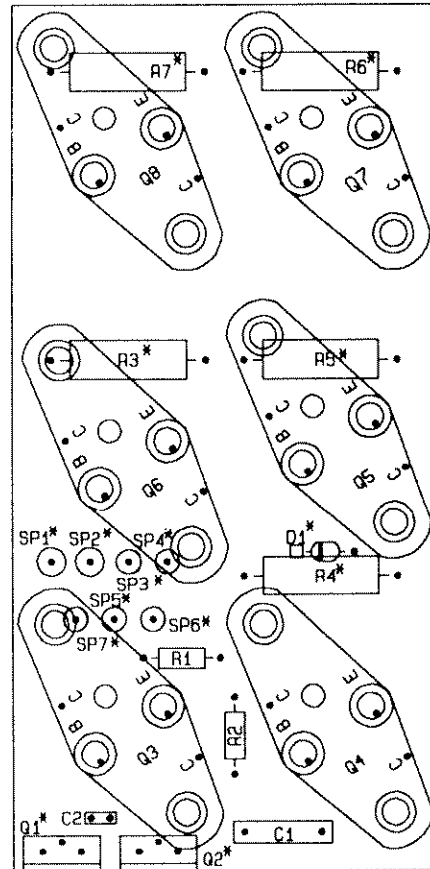

**PCBs: 047461
047462
047463
047763**

FROM DISTRIBUTION BO TO :
HEATSINKS L/ HEATSINKS R

+MAIN HEATSINK
PC BOARD 047461

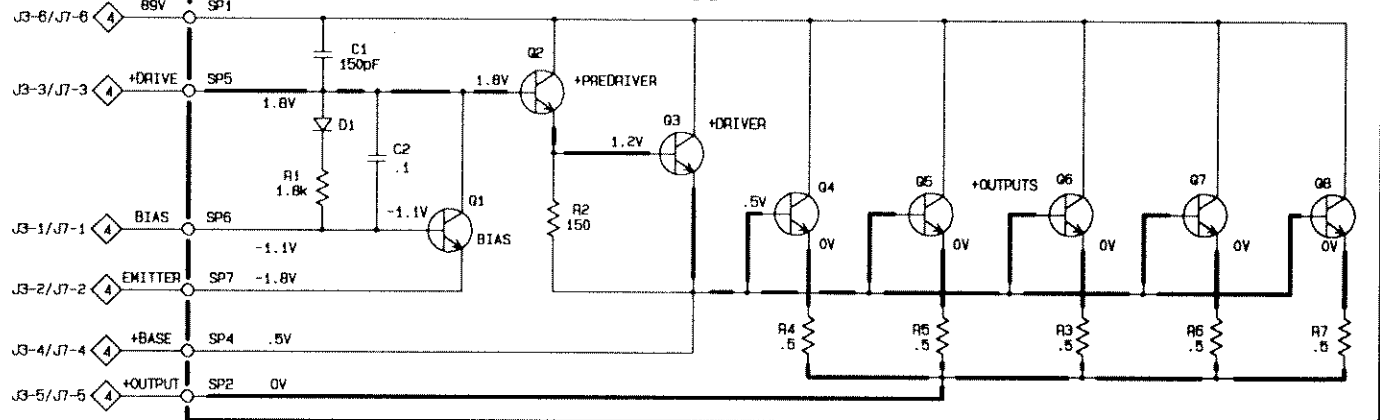

-MAIN HEATSINK
PC BOARD 047462

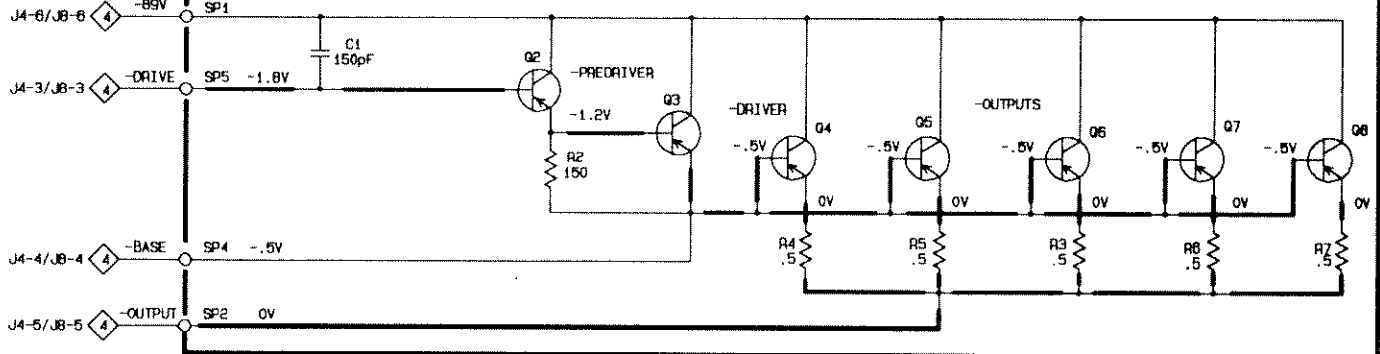

+SATELLITE HEATSINK
PC BOARD 047463

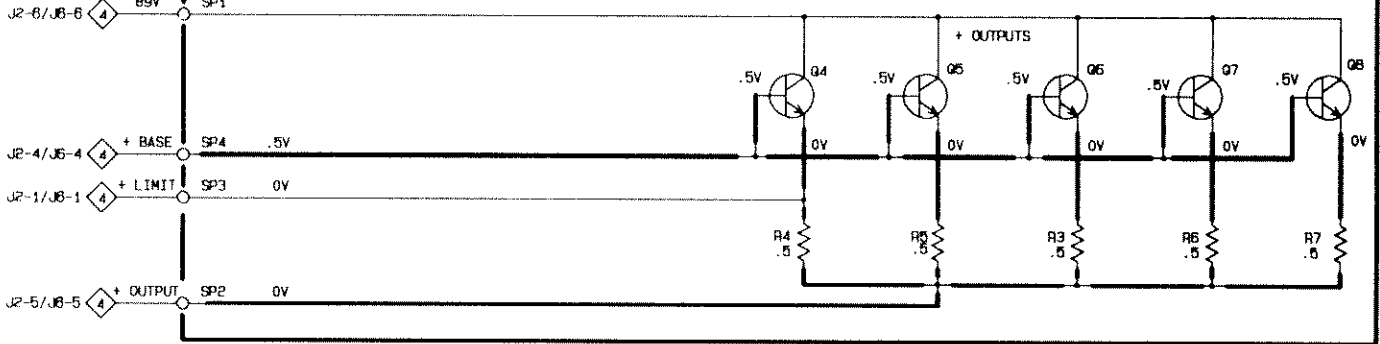

-SATELLITE HEATSINK
PC BOARD 047763

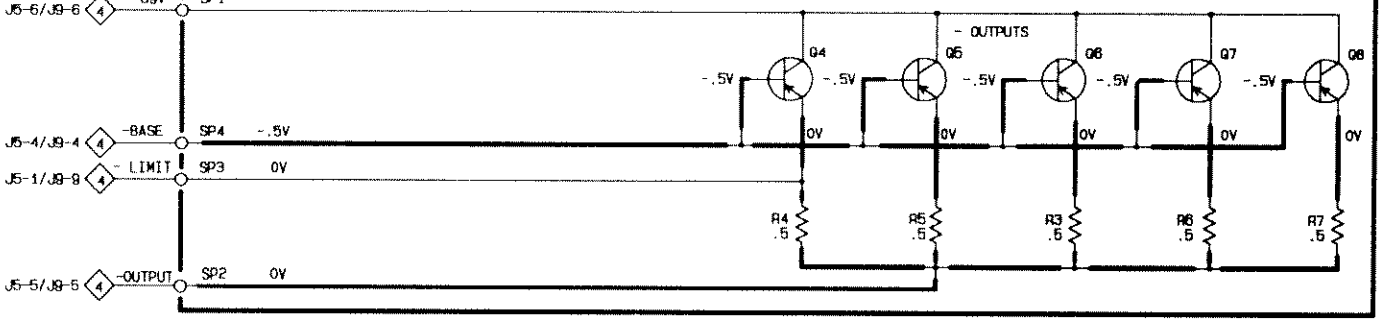

6 Relay and Power Control

WARNING: Parts located in the below shaded areas have critical characteristics. Use ONLY replacement parts recommended by the manufacturer.

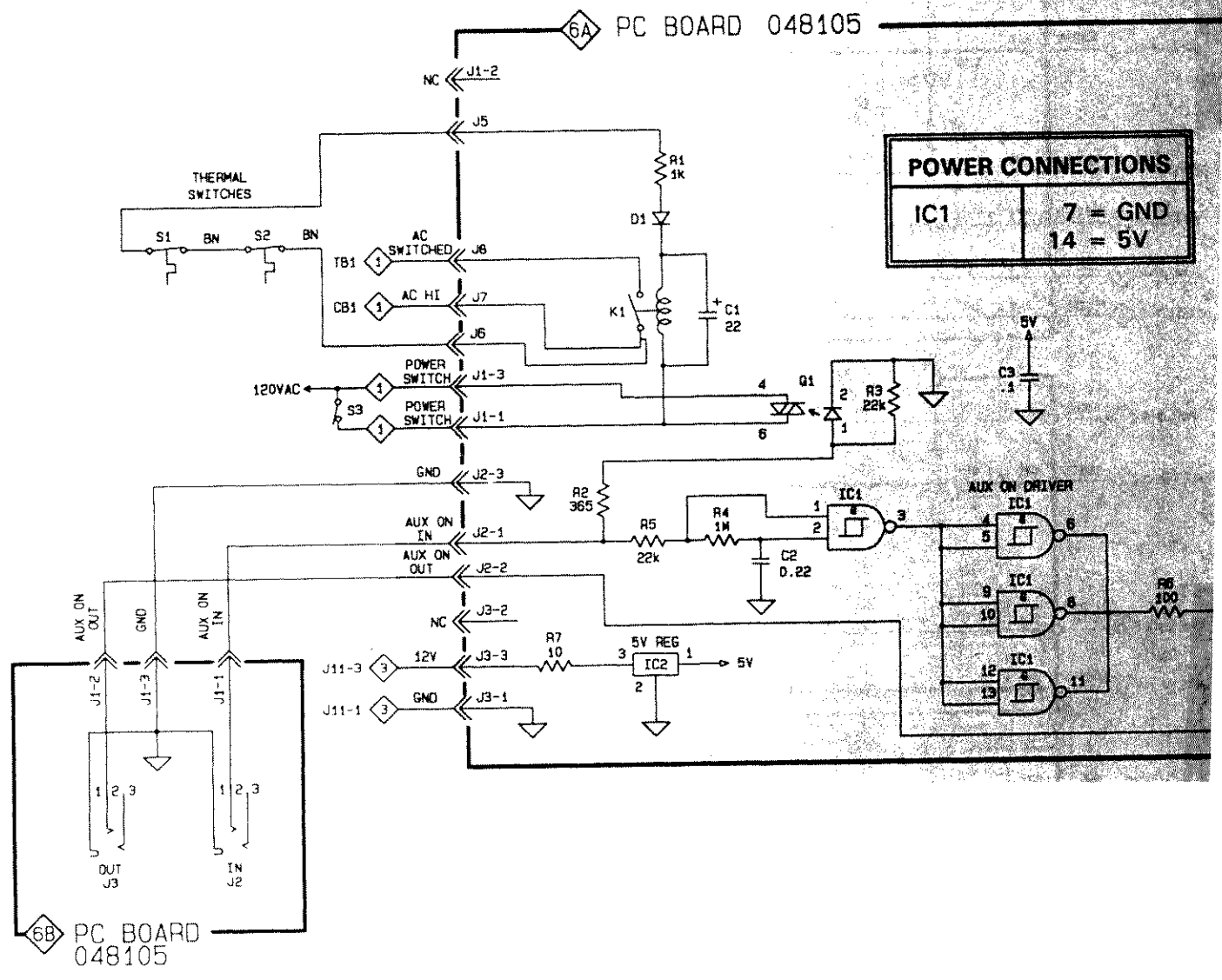

POWER CONNECTIONS	
IC1	7 = GND
	14 = 5V

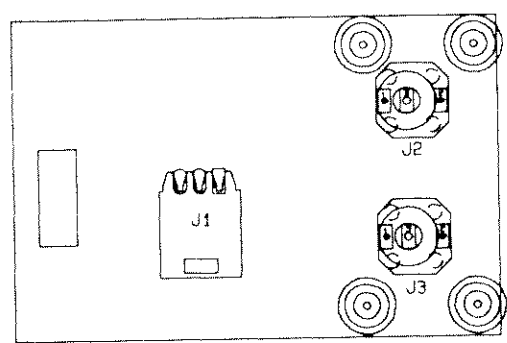

**POWER CONTROL
PORTION OF
PCB 048105**

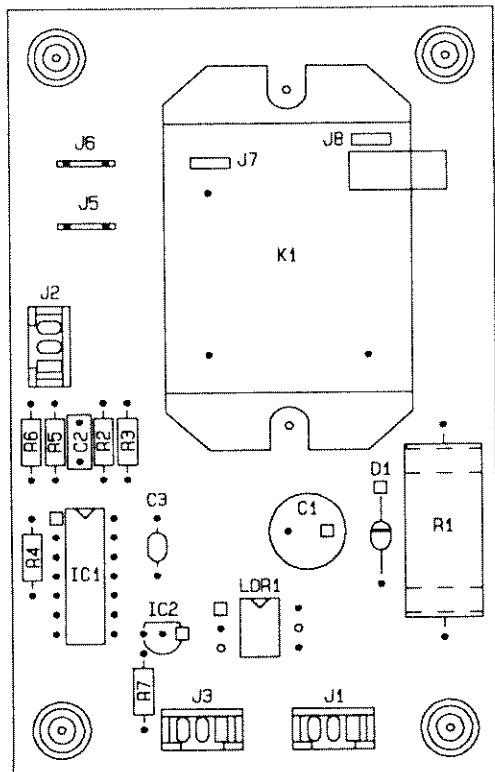

RELAY PCB 048105

RELAY PARTS LIST

<i>Symbol</i>	<i>Part</i>	<i>Description</i>
DIODES		
D1	070131	RECT, 400V, 1A, 1N4004
INTEGRATED CIRCUITS		
IC1	133192	CMOS, Quad 2-Input Schmitt-Trigger NAND Gate, MC74HC132
IC2	133093	+5V Regulator, MC78L05ACP
RELAYS		
K1	087049	SPST, TV-15, 48V, VFB48HU
TRANSISTORS		
Q1	131020	OPTO ISO, MOC3023

Repacking Instructions

In the event it is necessary to return the MC500 to McIntosh Laboratory for service, only use the original shipping carton if the carton and pads are in good serviceable condition.

If a shipping carton is needed, please call or write the Customer Service Department of McIntosh Laboratory. Order using the part numbers on the accompanying list.

Qty.	Part No.	Description
1	033628	Shipping Carton
1	033657	Shipping Carton Bottom
1	033629	Left End Cap
1	033630	Right End Cap

McIntosh

MC500 POWER AMPLIFIER

The continuous improvement of its products is the policy of McIntosh Laboratory Incorporated, who reserve the right to improve design without notice. Because of the constant upgrading of McIntosh products' circuitry and components, the Company cannot insure, and does not warrant, the accuracy of the within schematic material, which is intended for information only.

McIntosh Laboratory Inc., 2 Chambers Street, Binghamton, NY 13903
Telephone (607) 723-3512 Printed in U.S.A. Part No. 040270

BE022004