

MC 7150

STEREO POWER AMPLIFIER

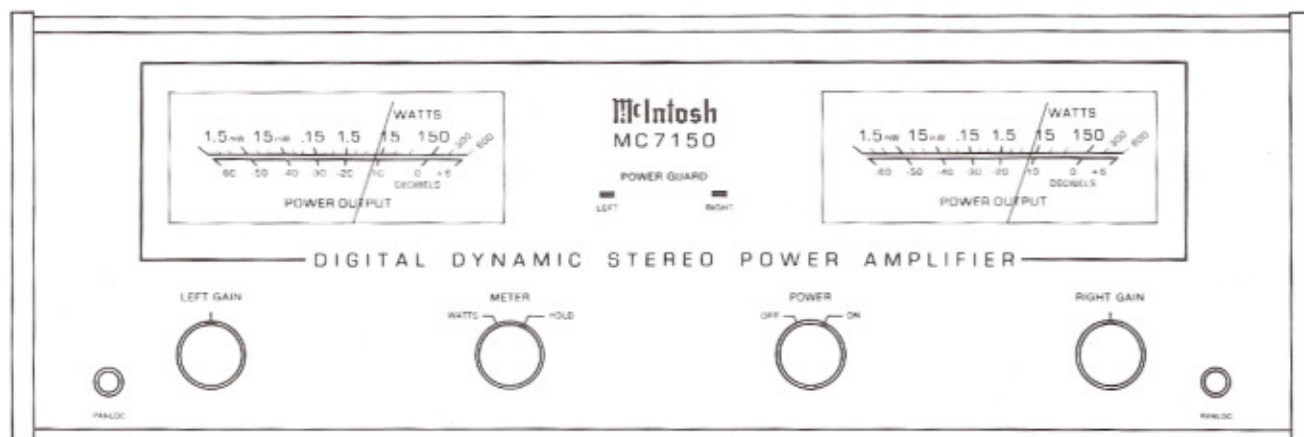

CONTENTS

Performance Specifications	2
Notes	2
Mechanical Views	3-4
Front Panel and Trim Parts List	4
Installation Parts List	4
Block Diagram	5-6
Section Locations	6
Section 1—Interconnection Diagram	7-9
Section 2—Power Supply/Meter	10-15
Section 3—Amplifier	16-20
Repacking Instructions	21

Performance Specifications

STEREO POWER OUTPUT

150 watts into 8, 4 or 2 ohm loads is the minimum sine wave continuous average power output per channel from 20Hz to 20,000Hz with both channels operating.

The output RMS voltage is:

- 34.6 across 8 ohms
- 24.5 across 4 ohms
- 17.3 across 2 ohms

OUTPUT LOAD IMPEDANCE

Stereo: 8, 4 or 2 ohms by connecting to the proper output terminals.

RATED POWER BAND

20Hz to 20kHz

TOTAL HARMONIC DISTORTION

Stereo: 0.005% maximum harmonic distortion at any power level from 250 milliwatts to rated power per channel from 20Hz to 20,000Hz, both channels operating.

INTERMODULATION DISTORTION

Stereo: 0.005% maximum if instantaneous peak power output does not exceed twice the output rating per channel, with both channels operating, for any combination of frequencies from 20Hz to 20,000Hz.

FREQUENCY RESPONSE (at one watt output)

- +0, -0.25dB from 20Hz to 20,000Hz
- +0, -3.0dB from 10Hz to 100,000Hz

HUM AND NOISE (A-weighted)

110dB below rated output

IHF DYNAMIC HEADROOM

1.8dB

DAMPING FACTOR

Greater than 40

INPUT IMPEDANCE

20,000 ohm

INPUT SENSITIVITY

1.4 volts (2.5V at gain control center detent)

POWER REQUIREMENT

120 volts, 50/60Hz, .5 to 7 amperes

Notes

1. The heavy lines on the schematics denote the primary signal path.
2. Unless otherwise specified:
 - a. Resistor values are in ohms.
 - b. Capacitor values smaller than 1 are in microfarads (μF) and greater than 1 are in picofarads (pF).
 - c. Inductor values are in microhenries (μH).
3. Unless otherwise noted, all voltages indicated on the schematics are measured under the following conditions:
 - a. AC input at 120 volts, 50/60Hz.
 - b. All voltages are $\pm 10\%$ with respect to ground.
A high impedance (10 megohm) voltmeter must be used.
 - c. Front panel controls are set at:
POWER.....ON
LEFT GAIN.....FULLY CW
RIGHT GAIN.....FULLY CW
METER SELECTOR.....WATTS
4. The voltages enclosed in a box are signal voltages that are measured with a 1.4V, 1kHz signal connected to both inputs.

Mechanical Views

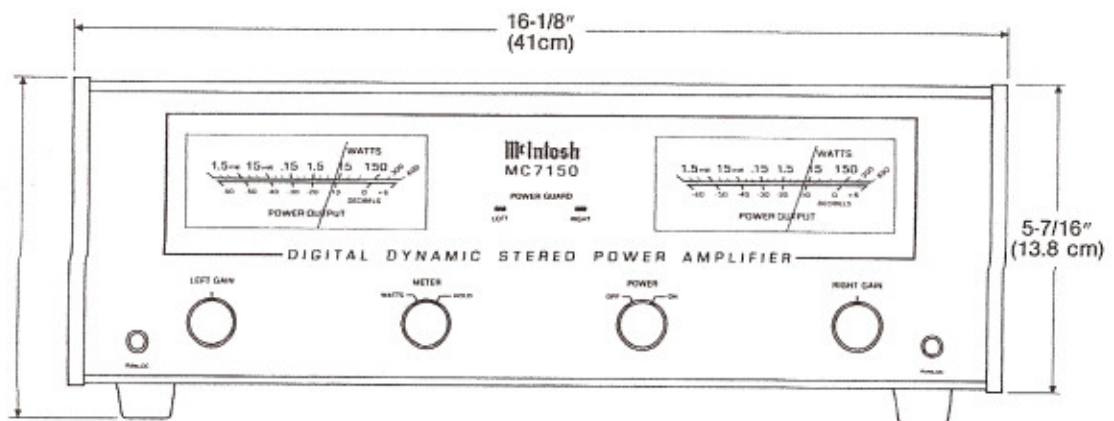
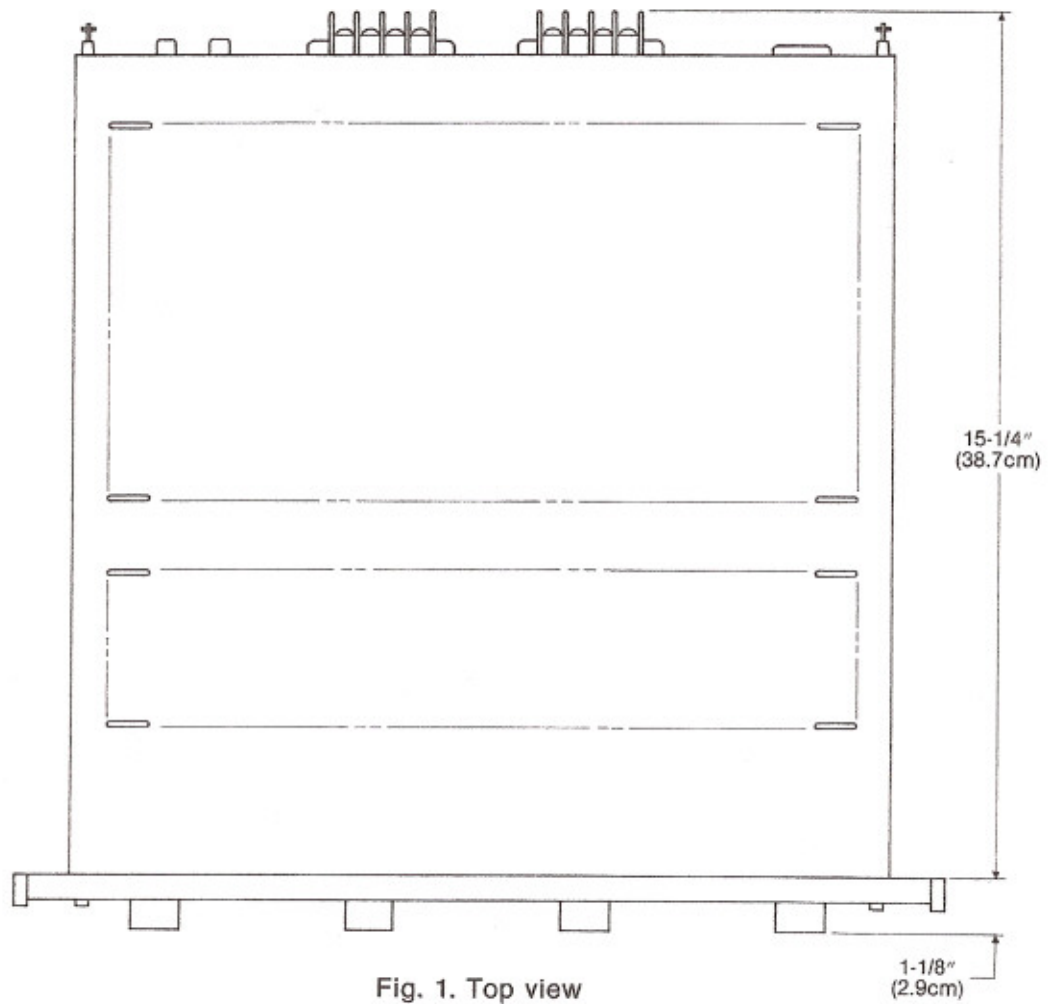

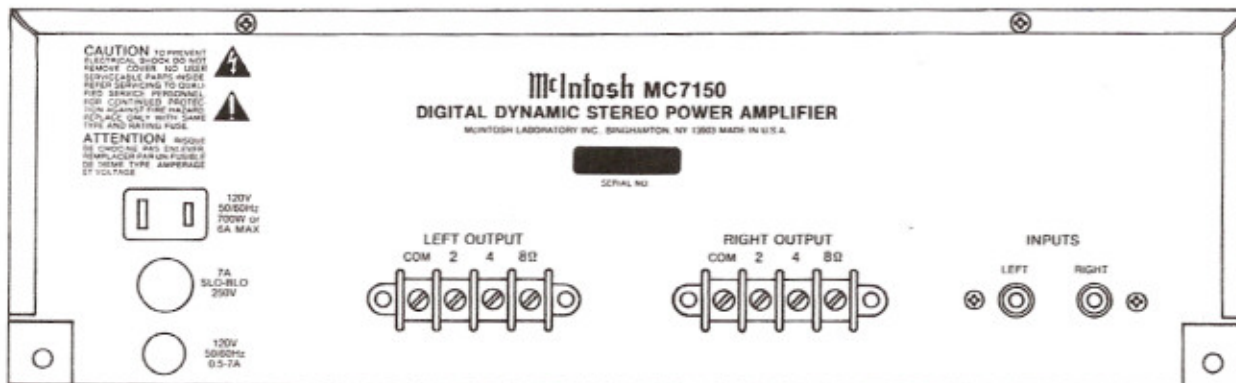

Fig. 3. Rear view

FRONT PANEL AND TRIM PARTS LIST

Part	Description
047149	Front Panel, Complete
047148	Front Panel, Glass
018232	End Cap
090214	Knob, Gain Controls
090224	Knob, Power, Meter
018369	Top Panel Rail
018397	Bottom Extrusion

INSTALLATION PARTS LIST

Part	Description
045142	Hardware Package
043401	Mounting Strips
260752	Mounting Template
003923	Panloc Bracket, Right
003924	Panloc Bracket, Left
017218	Plastic Feet

Block Diagram

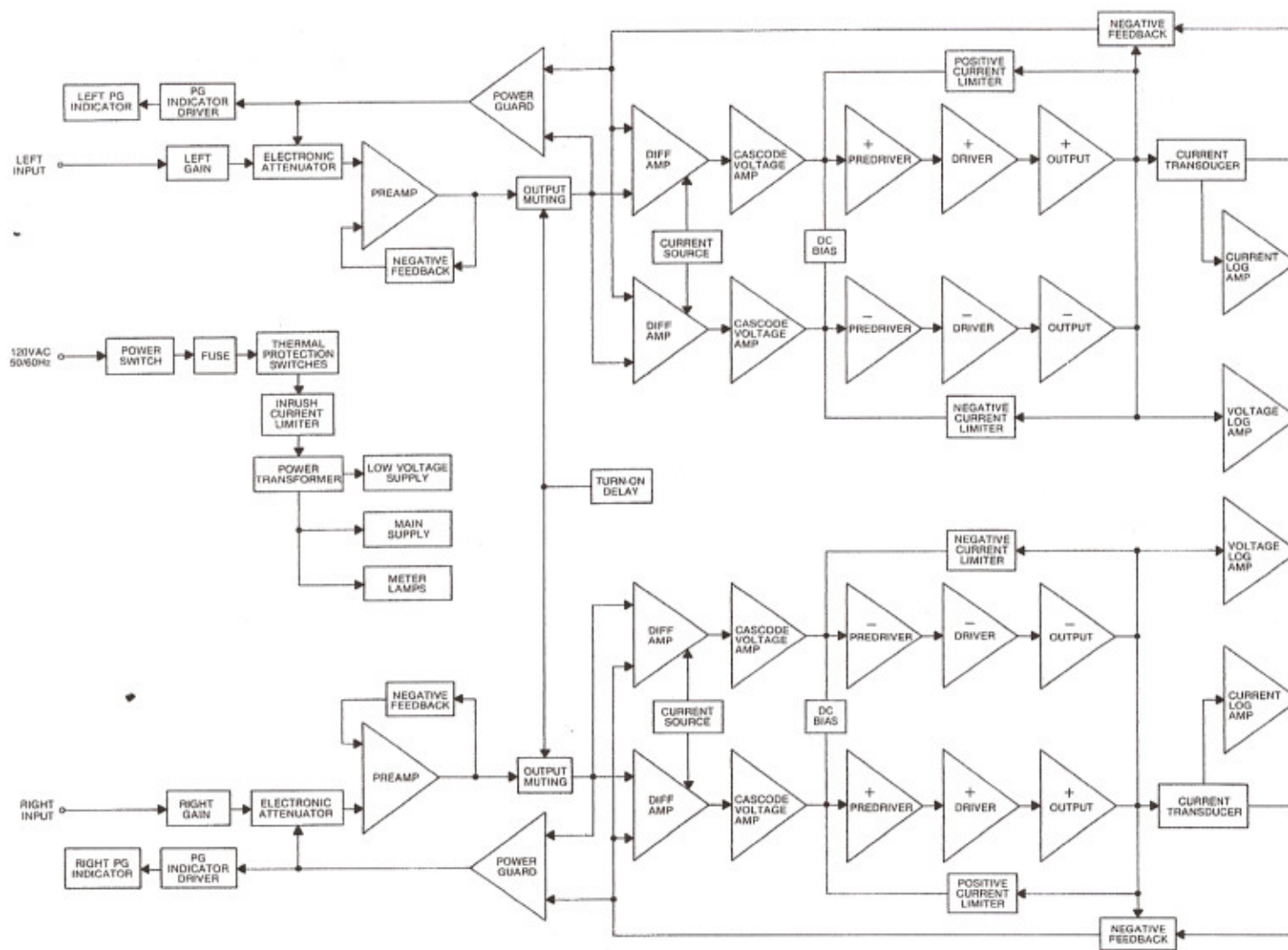

Section Locations

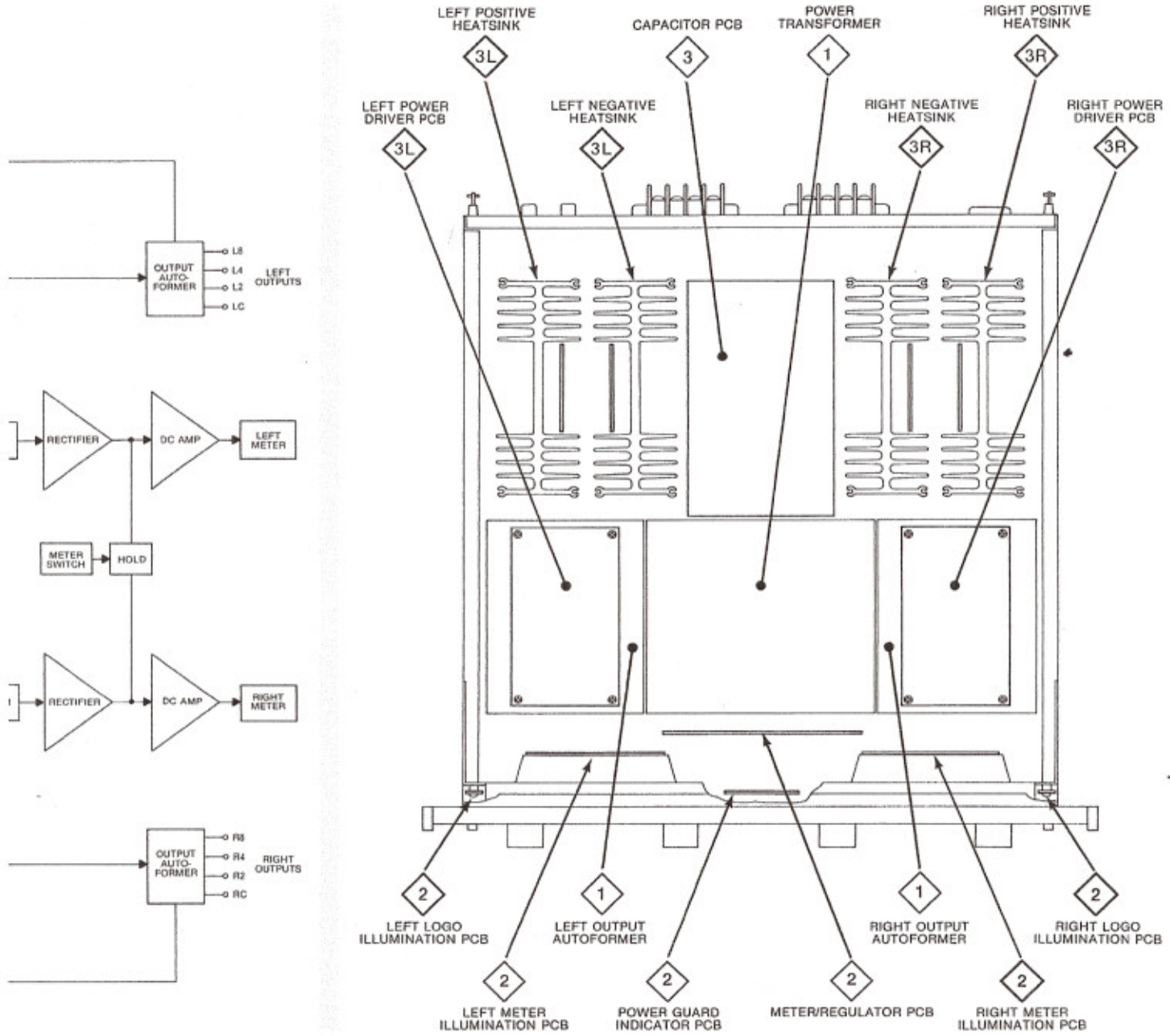
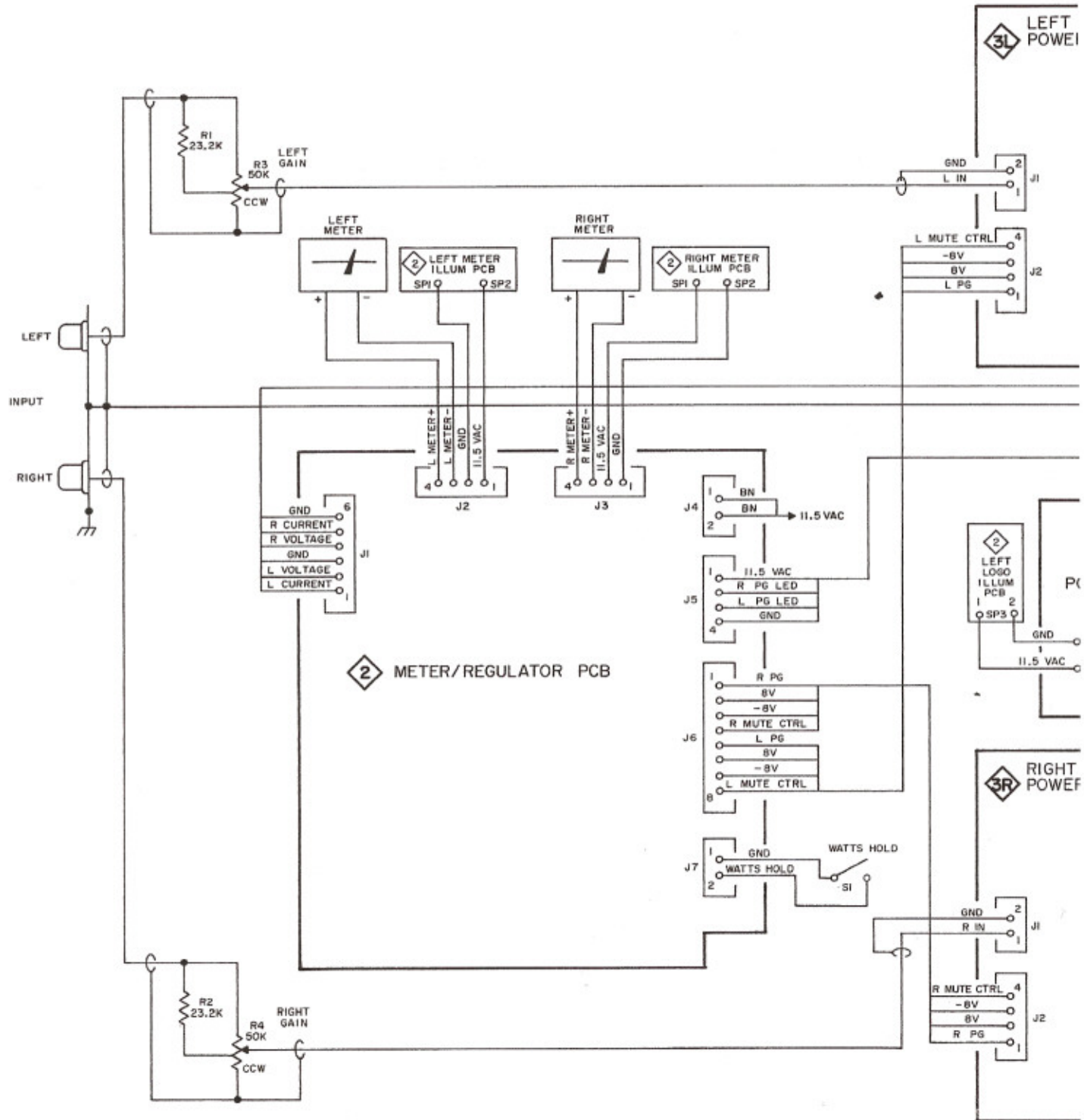
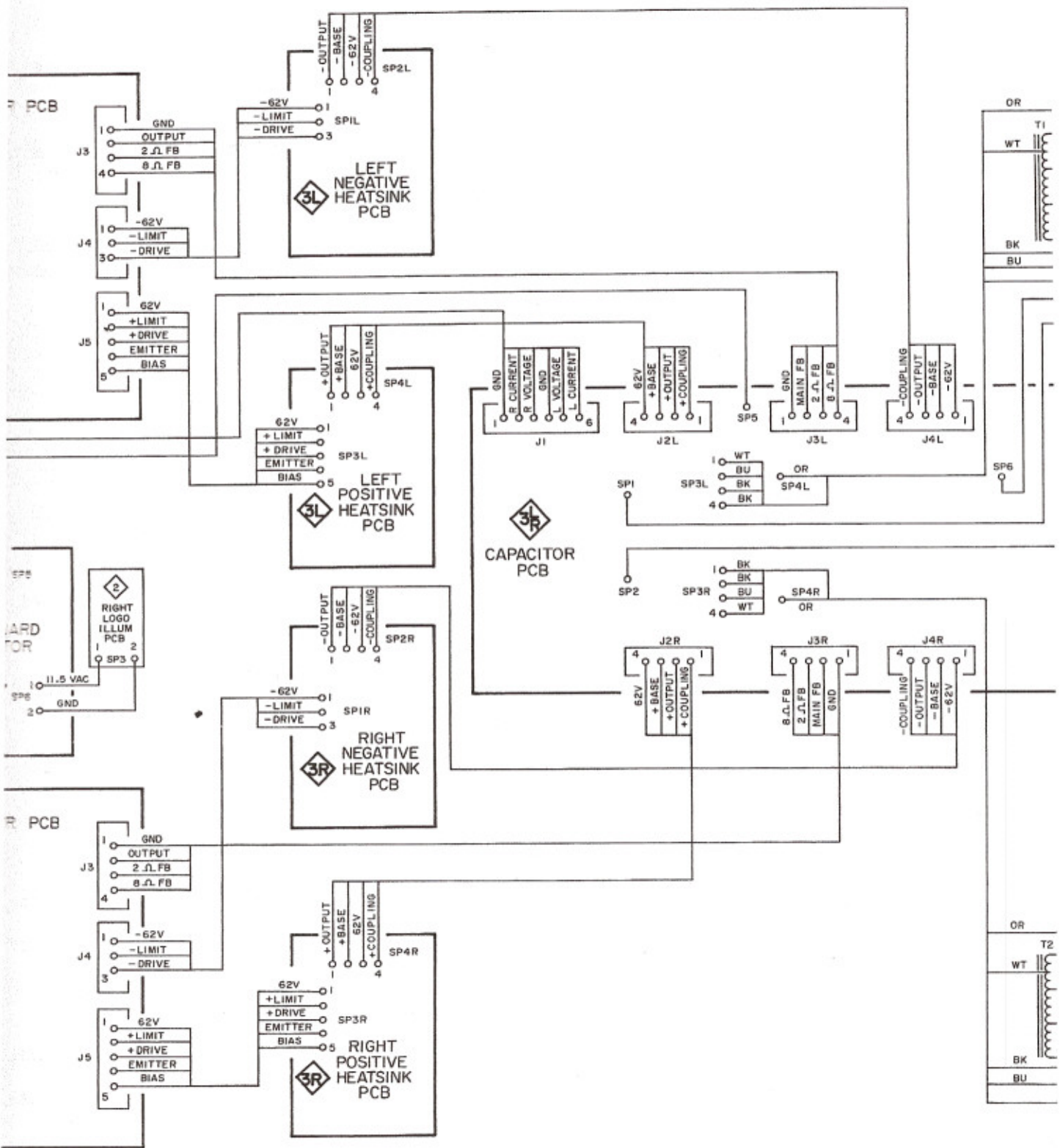
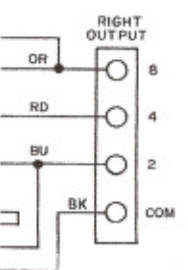
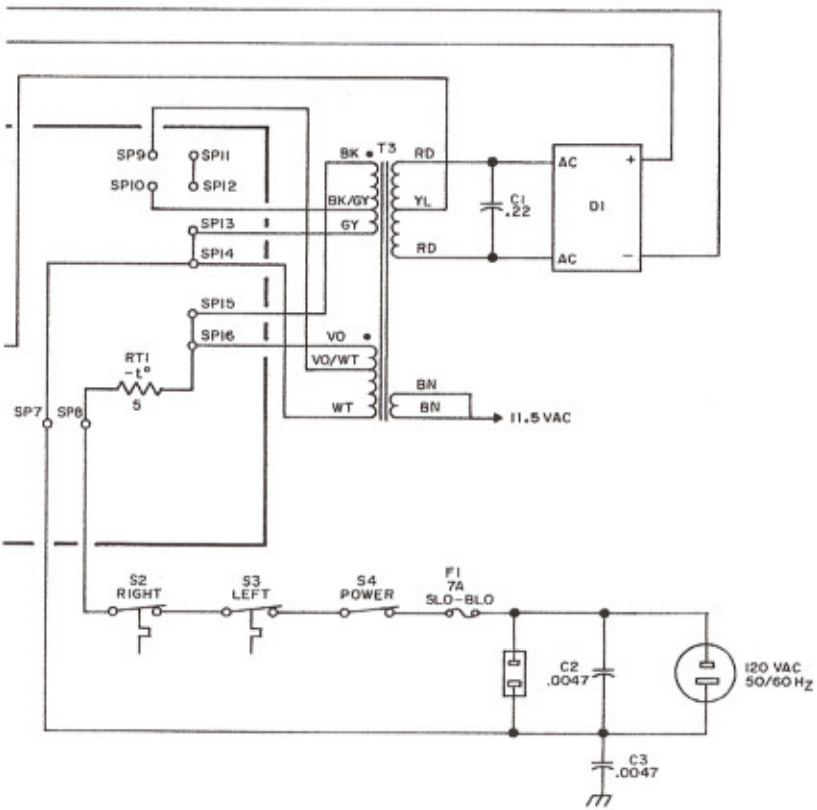
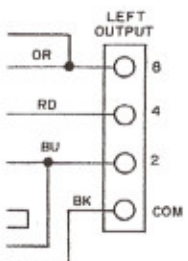

Fig. 4. Top view with cover removed

Interconnection Diagram







INTERCONNECTION PARTS LIST

Symbol	Part	Description
CAPACITORS		
C2, C3	016276	CD, 0.0047uF, 400V, UL/CSA
DIODES		
D1	070137	BRID, Rect, 400V, MDI4040
FUSES		
F1	089054	Fuse, SB, 7A, 250V
RESISTORS		
R3, R4	134442	POT, 50K ohm, Gain Control
THERMISTORS		
RT1	144151	Thermistor, 5 ohm
SWITCHES		
S1, S4	146183	Power Switch (on-off)
S2, S3	153017	Thermal Switch
TRANSFORMERS		
T1, T2	047142	Audio
T3	047141	Power

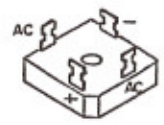

D1

2 Power Supply/Meter

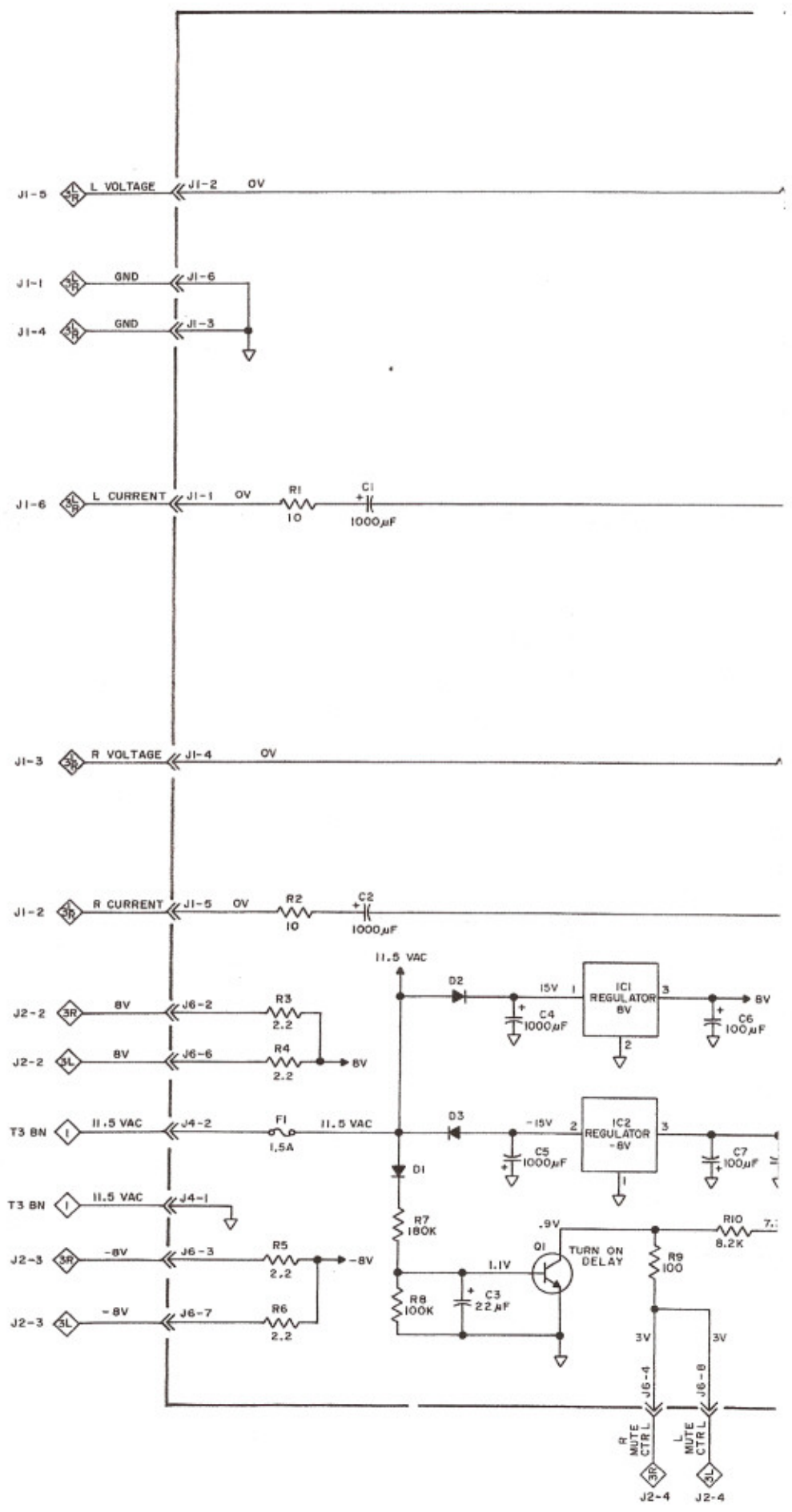

2 PC BOARD 047115
METER/REGULATOR

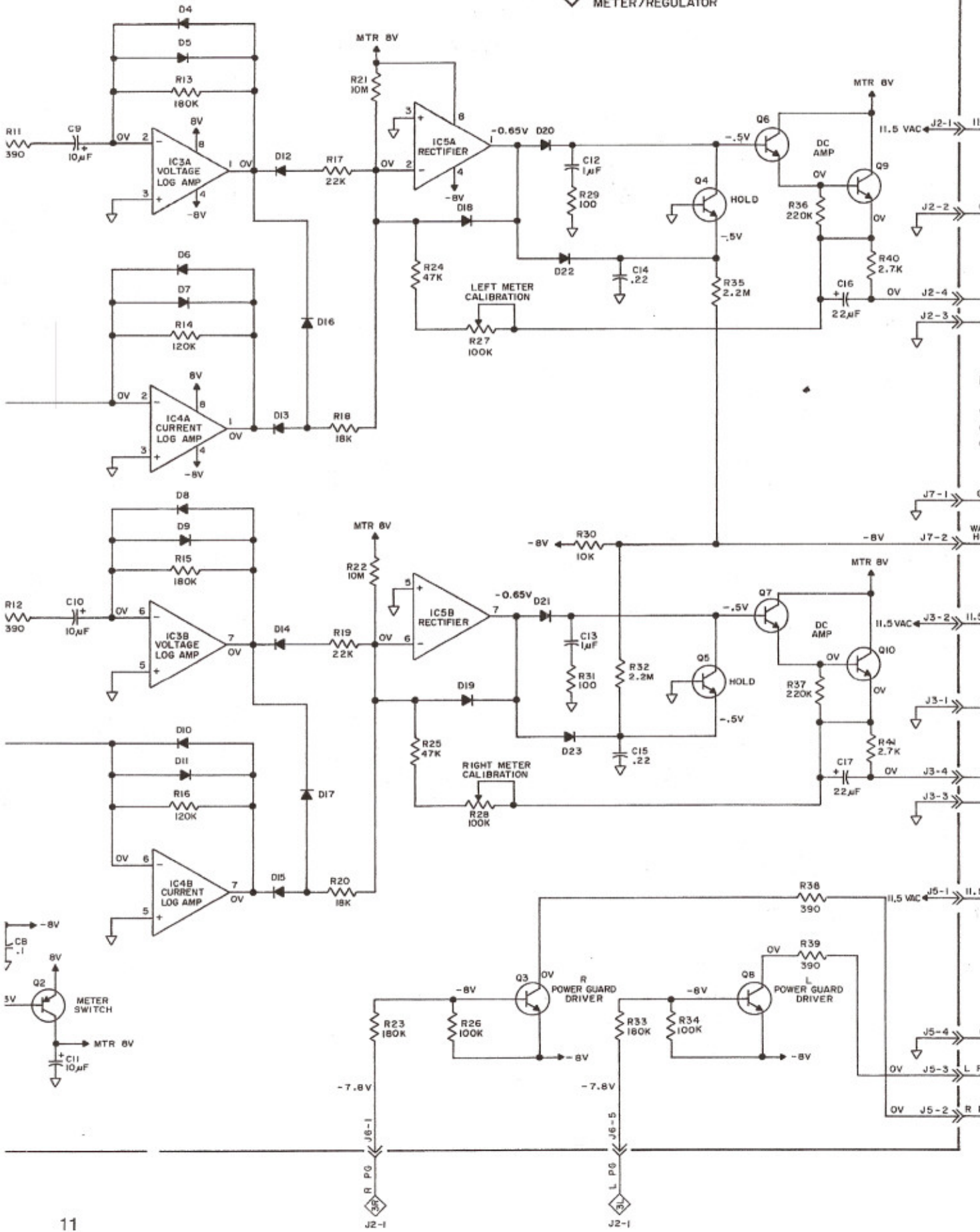

2

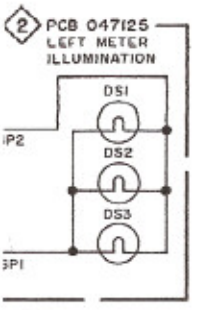

CALIBRATION
rate the amplifier at 1kHz with 150 into 8 ohm loads. Adjust both ation pots R27 (left) and R28 (right) so meter reads 150 watts.

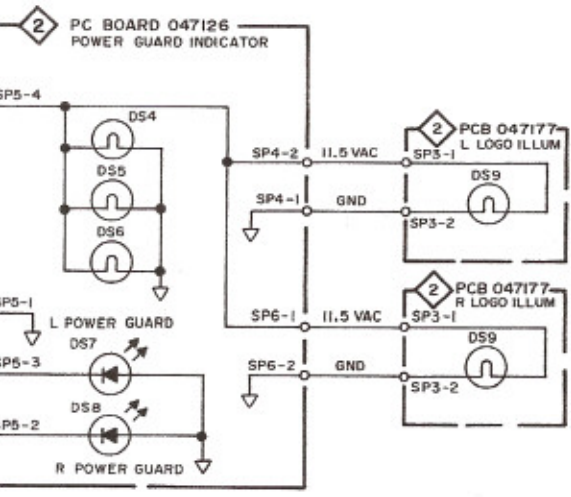
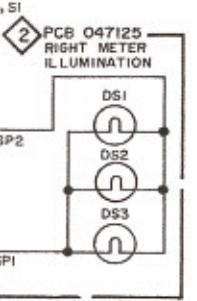

Power Supply/Meter 2

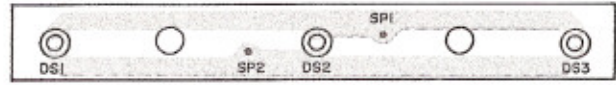

**METER ILLUMINATION
PCB 047125**

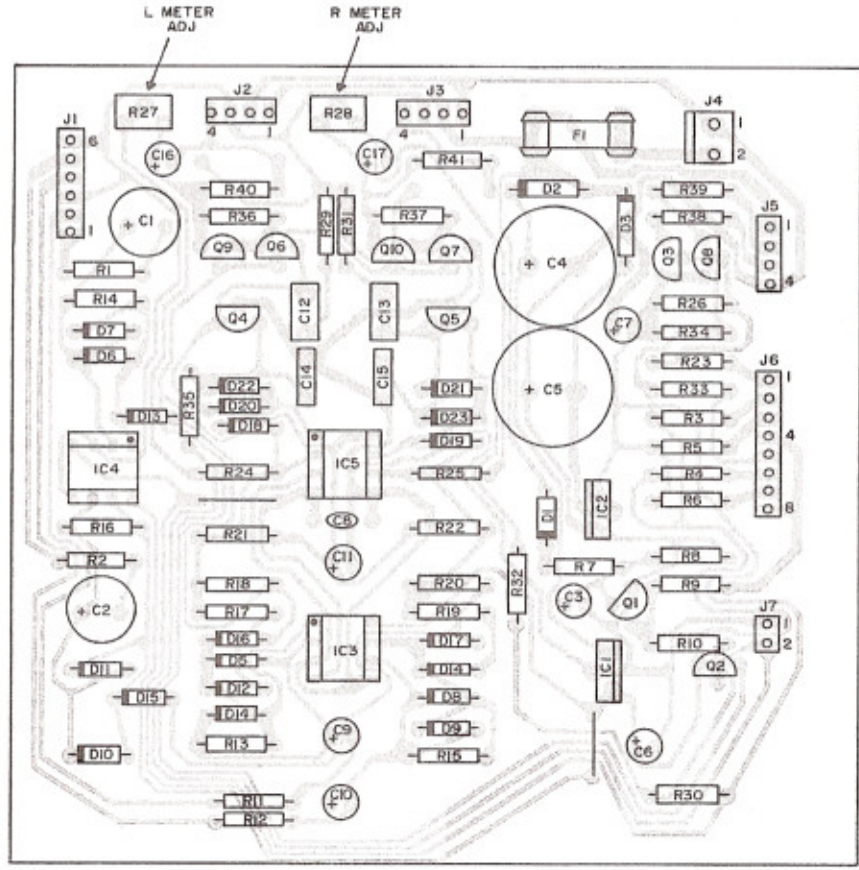

**METER REGULATOR
PCB 047115**

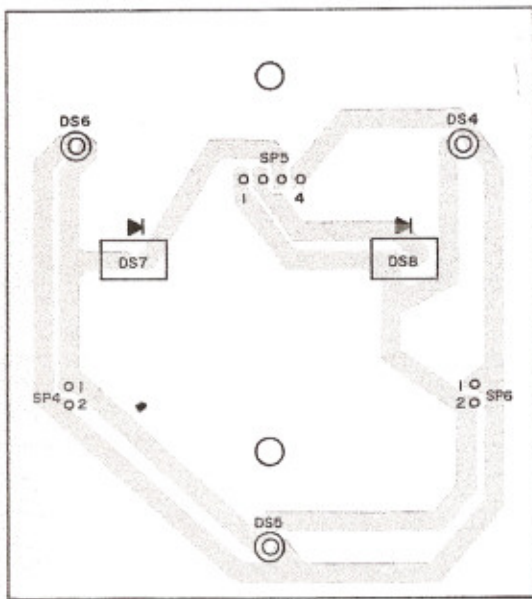

**POWER GUARD INDICATOR
PCB 047126**



**LOGO
ILLUMINATION
PCB 047177**

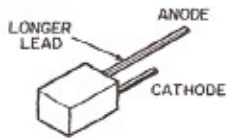

DS7, DS8

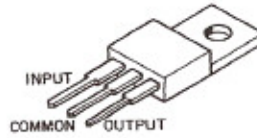

IC1

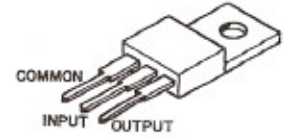

IC2

POWER SUPPLY/METER PARTS LIST

Symbol	Part	Description
DIODES		
D1	070047	SIG, 75V, 150mA, 1N4148
D2, D3	070131	RECT, 400V, 1A, 1N4004
D4-D19	070047	SIG, 75V, 150mA, 1N4148
D20, D21	070136	SIG, Low Leakage, FDH300
D22, D23	070047	SIG, 75V, 150mA, 1N4148
LIGHTING DEVICES		
DS1-DS3	058120	INC, 14V, 7373
DS4, DS6	058061	INC, 14V, 7382
DS5	058120	INC, 14V, 7373
DS7, DS8	058121	LED, Amber Bar, MV15-3101
D9	058120	INC, 14V, 7373
FUSES		
F1	089052	Fuse, 5B, 1.5A, 250V, 2AG
INTEGRATED CIRCUITS		
IC1	133165	+8V Regulator, 78M08CT
IC2	133166	-8V Regulator, 7908CT
IC3, IC4	133028	Dual HI-speed Operational Amp, MC4558CP1
IC5	133094	Dual Operational Amp, NE5532N
METERS		
M1, M2	124046	Meter
TRANSISTORS		
Q1, Q3	132090	NPN, DAR, MPSA25
Q2	132224	PNP, MPS4126
Q4, Q5	132223	NPN, MPS4124
Q6, Q7	132254	NPN, 2SC2362KG
Q8	132090	NPN, DAR, MPSA25
Q9, Q10	132254	NPN, 2SC2362KG

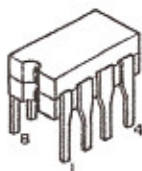

IC3-IC5



Q1-Q5, Q8



Q6, Q7, Q9, Q10

Amplifier

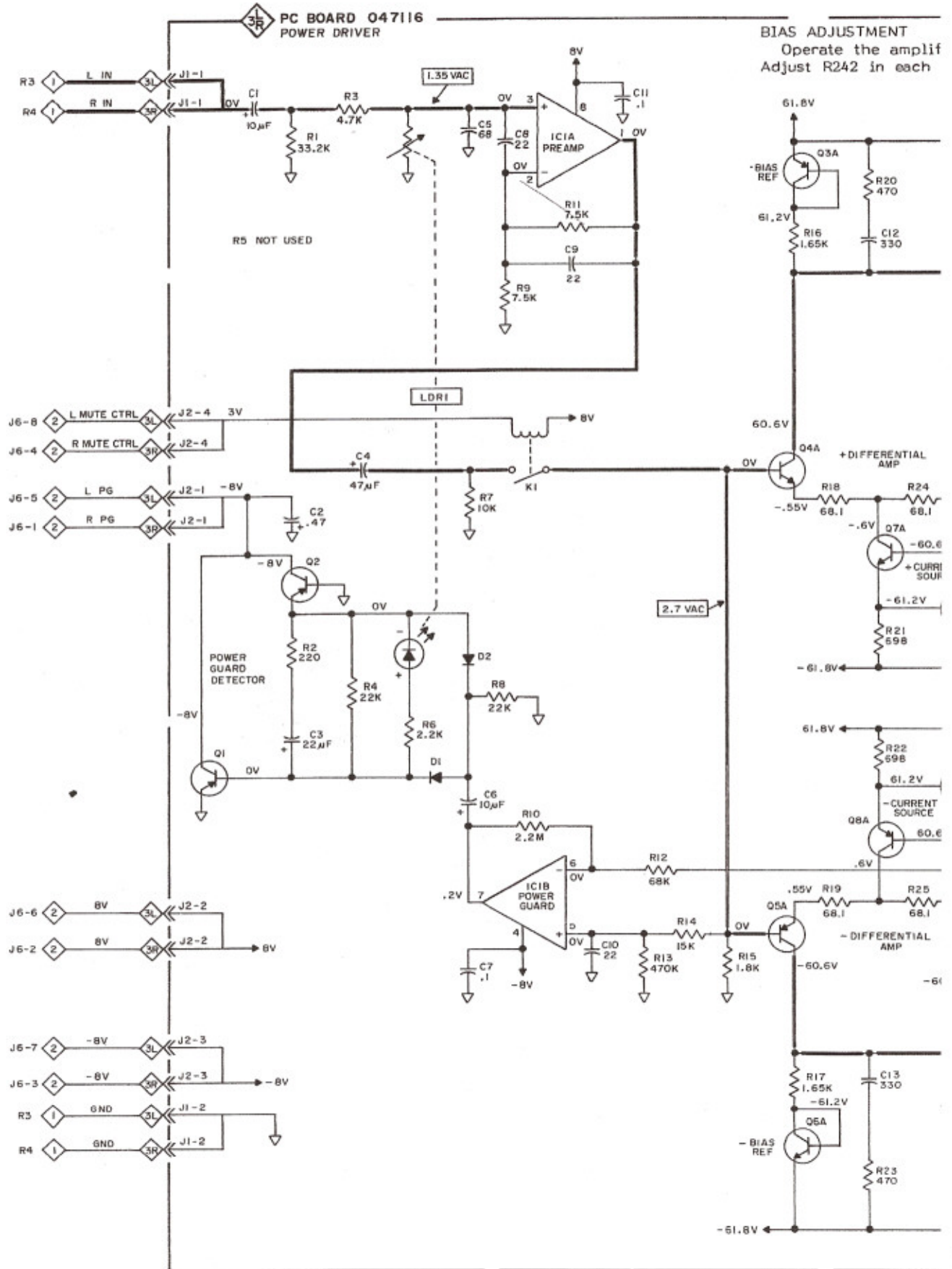

ier for 2 minutes or longer with no output. Heatsinks must NOT be hot.
channel for $13 \pm 2mV$ DC across TP1 and TP2 on the Power Driver PC board.

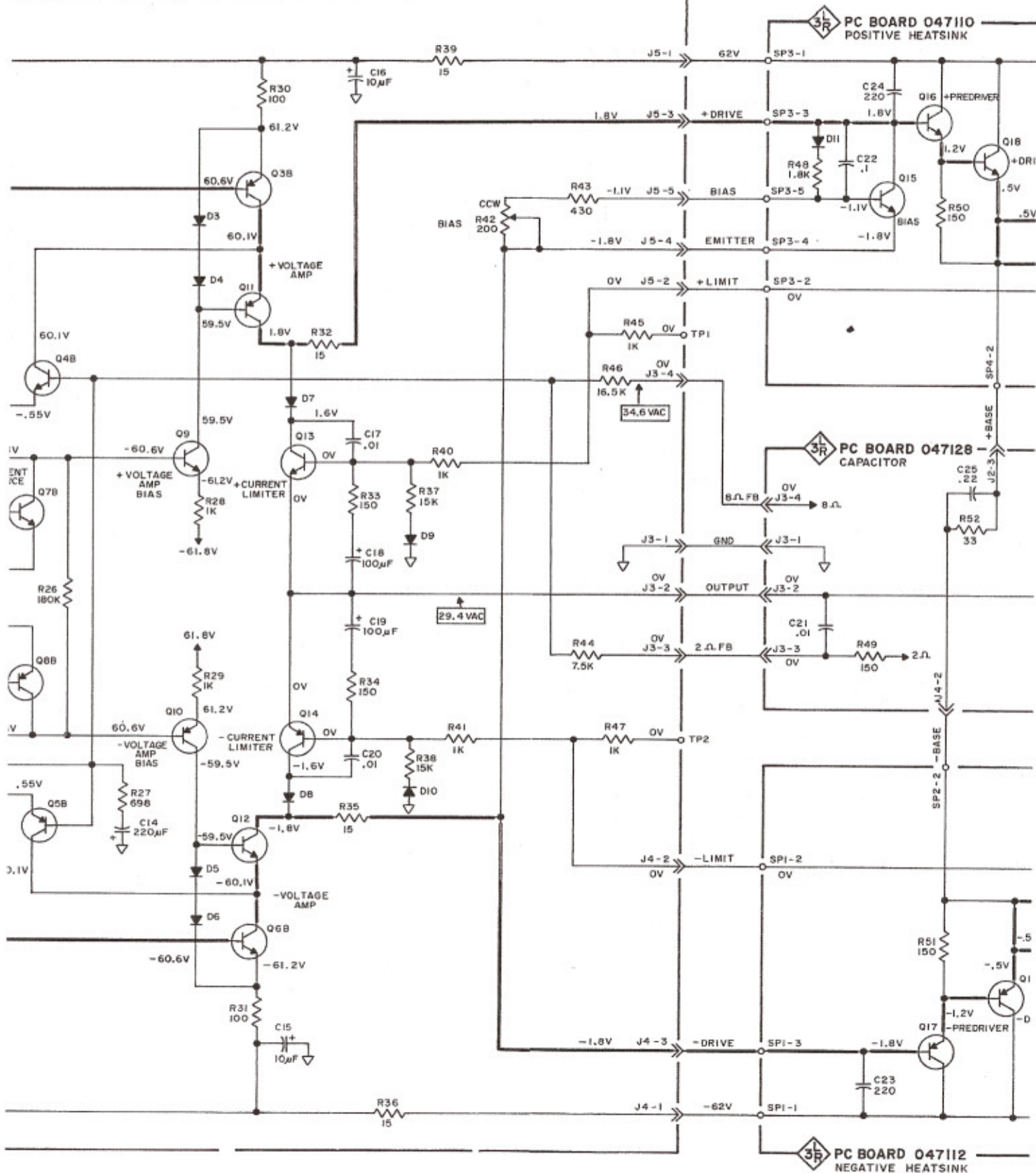

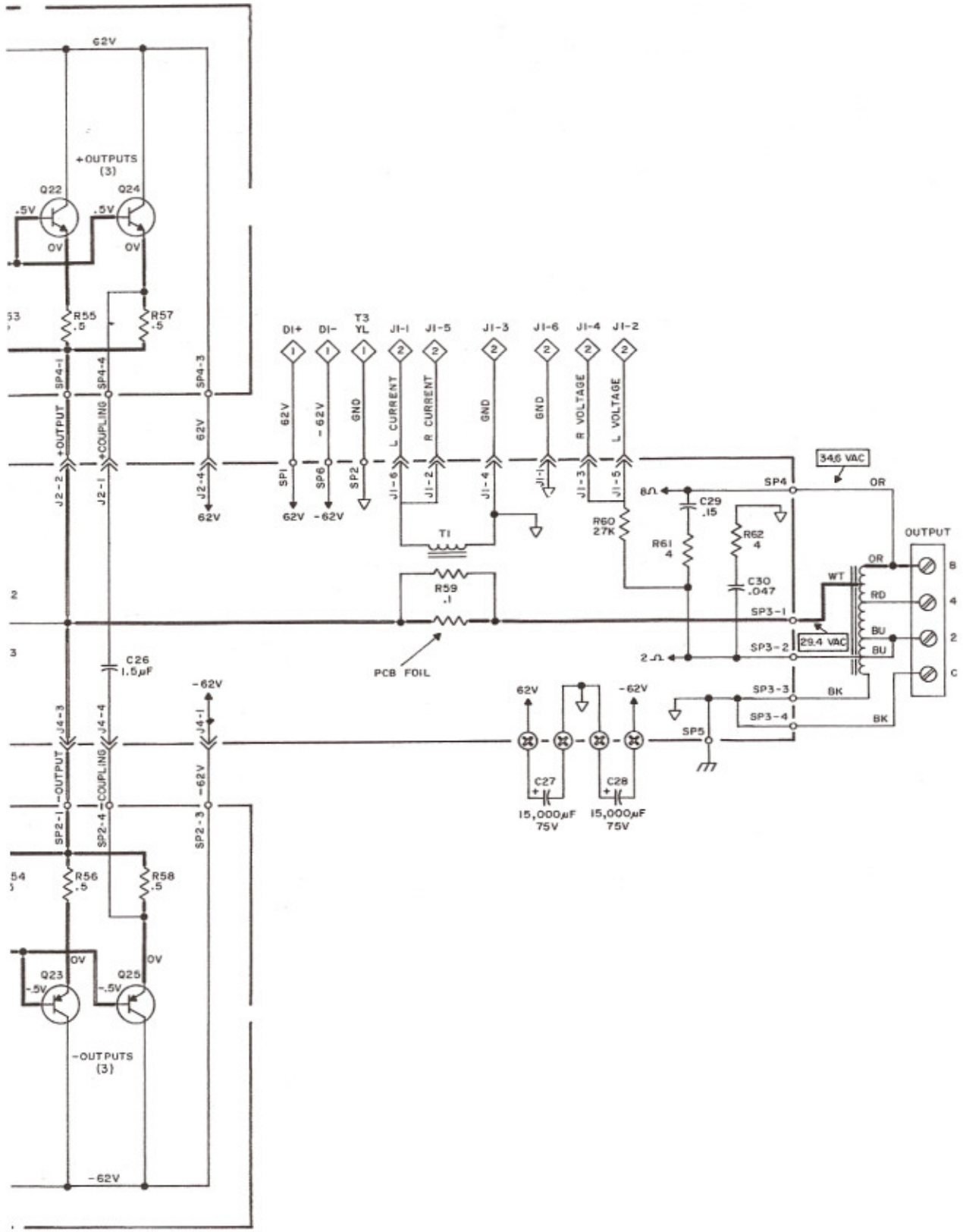

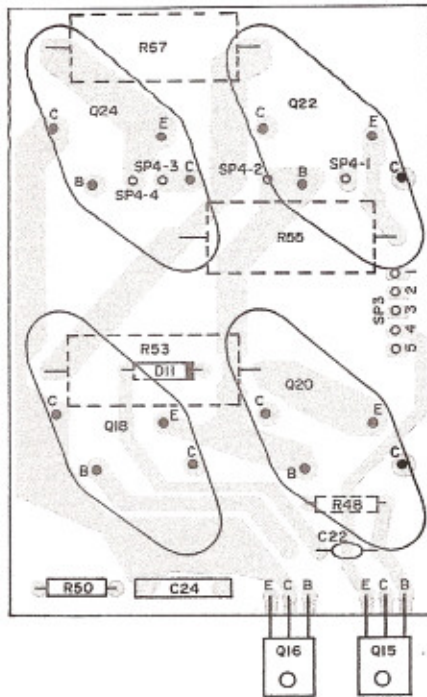

**POSITIVE HEATSINK
PCB 047110**

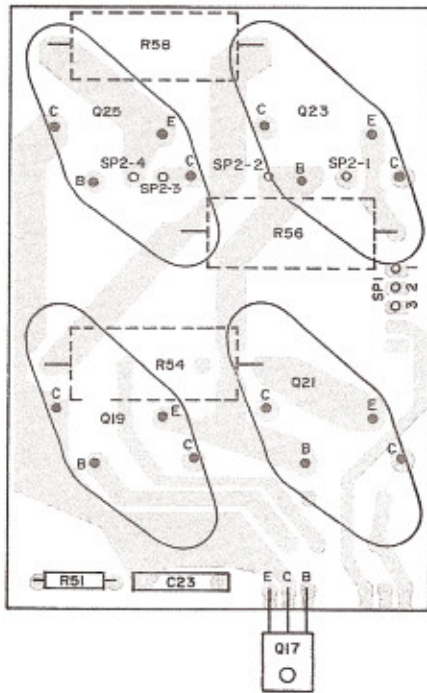

**NEGATIVE HEATSINK
PCB 047112**

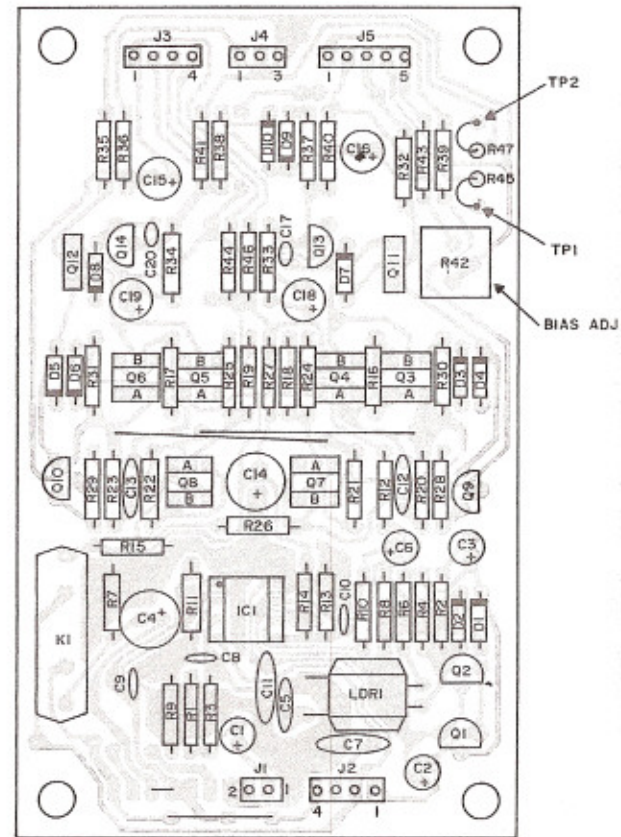

**POWER DRIVER
PCB 047116**

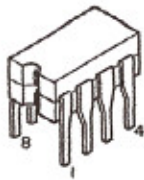

IC1

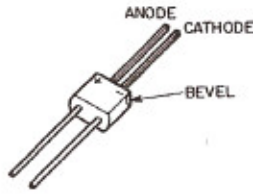

LDR1



Q1, Q2, Q9, Q10,
Q13, Q14

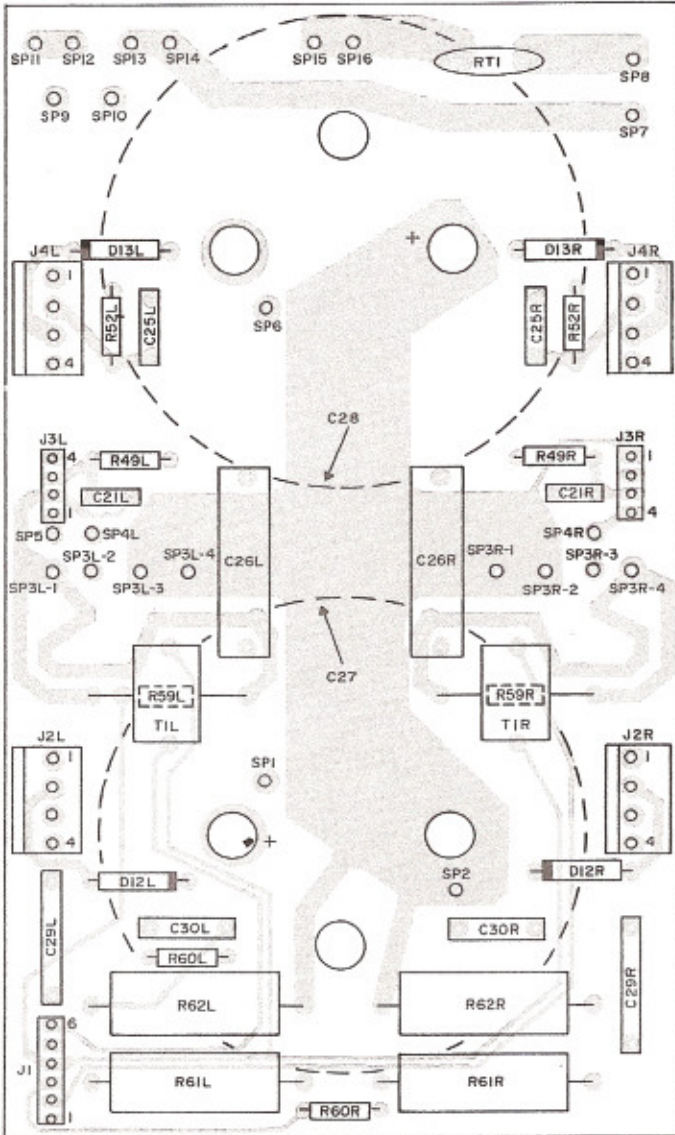

**CAPACITOR
PCB 047128**

AMPLIFIER PARTS LIST

Symbol	Part	Description
CAPACITORS		
C27, C28	066405	ELECT, 15,000uF, 75V
DIODES		
D1-D11	070047	SIG, 75V, 150mA, 1N4148
D12, D13	070031	RECT, 400V, 1.5A
INTEGRATED CIRCUITS		
IC1	133094	Dual Operational Amp, NE5532N
RELAYS		
K1	087050	SPST, 5VDC, Reed, HE3321A0400
LIGHT DEPENDENT RESISTORS		
LDR1	144179	LDR, VTL5C9
TRANSISTORS		
Q1, Q2	132224	PNP, MPS4126
Q3	132253	PNP, Dual, 2SA1237G
Q4	132250	NPN, Dual, 2SC3066G
Q5	132251	PNP, Dual, 2SA1239G
Q6	132252	NPN, Dual, 2SC3064G
Q7	132250	NPN, Dual, 2SC3066G
Q8	132251	PNP, Dual, 2SA1239G
Q9	132136	NPN, MPSA42
Q10	132147	PNP, MPSA92
Q11	132249	PNP, 2SA1480D or 2SA1480E
Q12	132248	NPN, 2SC3790D or 2SC3790E
Q13	132223	NPN, MPS4124
Q14	132224	PNP, MPS4126
Q15, Q16	132248	NPN, 2SC3790D or 2SC3790E
Q17	132249	PNP, 2SA1480D or 2SA1480E
Q18	132246	NPN, MJ15020
Q19	132247	PNP, MJ15021
Q20	132212	NPN
Q21	132213	PNP
Q22	132212	NPN
Q23	132213	PNP
Q24	132212	NPN
Q25	132213	PNP
TRANSFORMERS		
T1	159215	Current

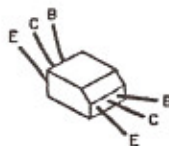

Q3-Q8

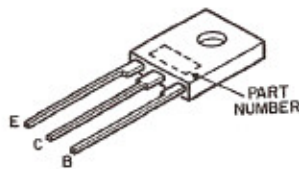

Q11, Q12, Q15-Q17

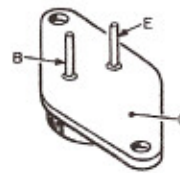

Q18-Q25

Repacking Instructions

In the event it is necessary to repack the MC 7150 for shipment, the unit must be packed exactly as shown below. The shelf brackets do not have to be included in the carton for the unit to be packed properly, but their position in the carton is indicated.

IMPORTANT - The four plastic feet must be attached to the bottom of the MC 7150 so they will locate in the four holes of the bottom pad. Three #10 x 2" screws and washers must be used to fasten the unit securely to the bottom pad and wood skid. Failure to do this will result in shipping damage.

If a shipping carton or any of the interior parts is needed, please call or write the Customer Service Department of McIntosh Laboratory. Order parts from the accompanying list by part number.

Use the original shipping carton and interior parts only if they are all in good serviceable condition.

Qty	Part No.	Description
1	033572	Shipping carton only
2	033087	18" x 36" Air-cushion pad
4	033086	12" x 18" Air-cushion pad
4	033579	Corner post
1	033578	Inside carton only
1	033336	Top pad
1	033525	Panloc pad
1	033573	Bottom pad
1	033571	Wood skid
3	101034	#10 x 2" Sheetmetal screw
3	104033	#10 x 1-3/4" Flat washer
4	017218	Plastic foot
4	100159	#10-32 x 3/4" Machine screw
4	104083	#10 x 7/16" Flat washer
1	033587	Shipping carton complete with all the above parts

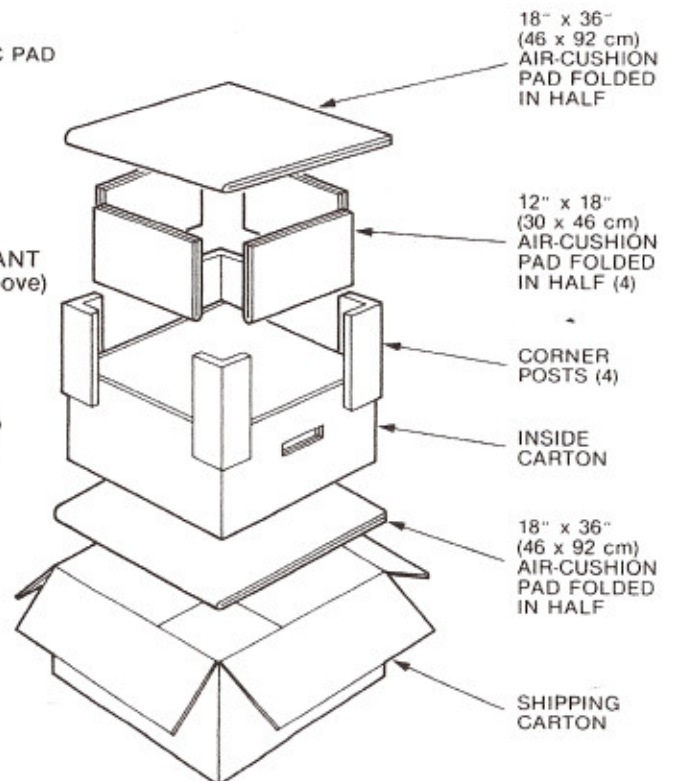
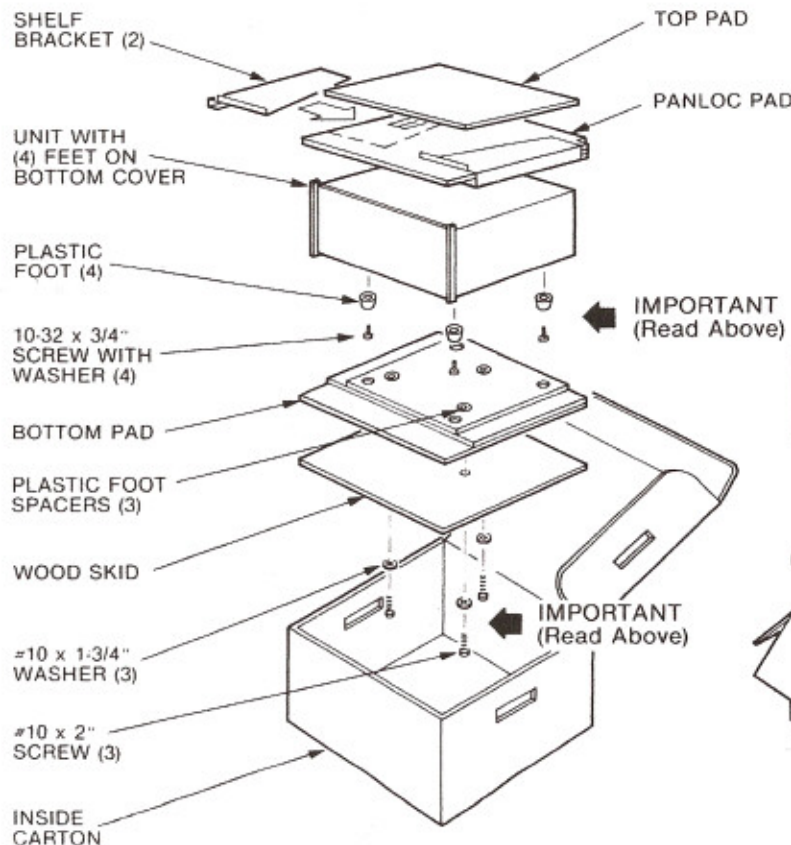

McIntosh[®]

MC7150 STEREO POWER AMPLIFIER

The continuous improvement of its products is the policy of McIntosh Laboratory Incorporated, who reserve the right to improve design without notice. Because of the constant upgrading of McIntosh products' circuitry and components, the Company cannot insure, and does not warrant, the accuracy of the within schematic material, which is intended for information only.

McIntosh Laboratory Inc. 2 Chambers Street Binghamton, NY 13903-2699

Part No. 039749

Printed in U.S.A.

Telephone (607)723-3512