

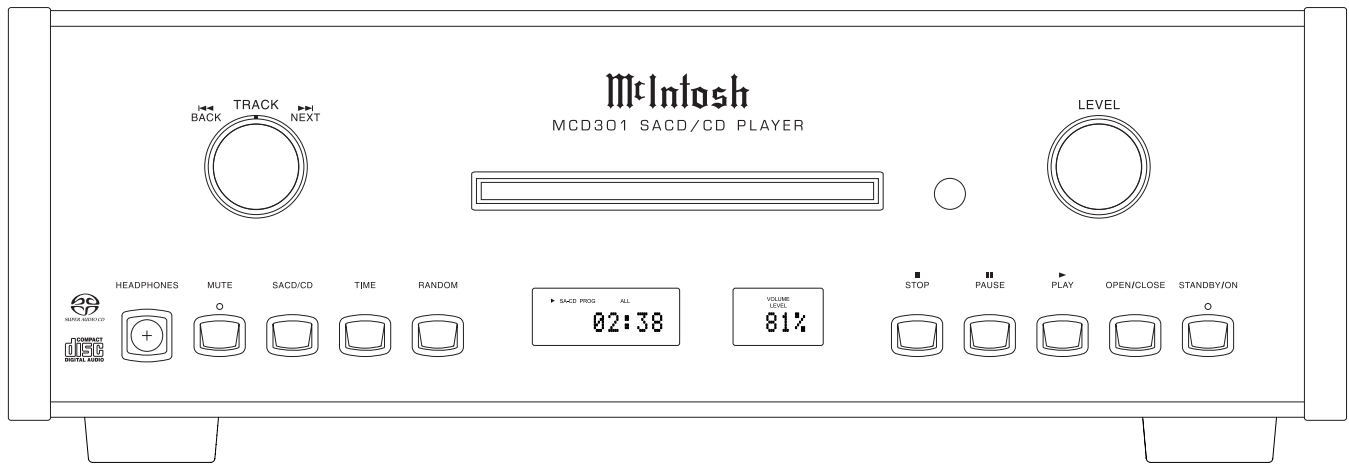

MCD301

SACD / CD PLAYER

SERIAL NO. YM1001 And Above



CONTENTS

Performance Specifications.....	2	Display Schematic and PCB.....	17 - 20
Notes.....	3	Control Schematic and PCB.....	21 - 22
Safety Information	3	Power Schematic and PCB.....	23 - 24
Rear Panel	5	Primary Schematic and PCB	27 - 28
Section Location.....	5	Headphone Schematic and PCB.....	29 - 30
Block Diagram	6	Parts List	31 - 36
Interconnection Diagram.....	7 - 8	Repacking Instructions.....	37
Main Schematic and PCB	9 - 16		

SERVICE MANUAL

PERFORMANCE SPECIFICATIONS

Audio Specifications

Fixed Output level

2.0Vrms Unbalanced
4.0Vrms Balanced

Variable Output level

0 - 6.0Vrms Unbalanced
0- 12.0Vrms Balanced

Output Impedance

600 ohms Unbalanced and Balanced

Frequency Response

4Hz to 40,000Hz, +0.5, -3dB (SACD)
4Hz to 20,000Hz, ±0.5dB (CD)

Signal to Noise Ratio

Better than 110dB (A-weighted)

Dynamic Range

Better than 100dB

Harmonic Distortion

0.002% @ 1000Hz (SACD)
0.003% @ 1000Hz (CD)

Channel Separation

Better than 98dB (1,000Hz)

General Specifications

Digital Output

Optical: - 15dbm to -21dbm (PCM)
Coaxial: 0.5V p-p/75 ohm (PCM)
Sampling Frequencies: 44.1kHz (PCM)

Transport

Laser Type: Twin Beam
Laser Beam Wavelength: 650nm (SACD)/790nm (CD)
Laser Power: CLASS IIa/CLASS I

Power Requirements

100 Volts, 50/60Hz at 35 watts
110 Volts, 50/60Hz at 35 watts
120 Volts, 50/60Hz at 35 watts
220 Volts, 50/60Hz at 35 watts
230 Volts, 50/60Hz at 35 watts
240 Volts, 50/60Hz at 35 watts

Standby: Less than 1 watt

Note: Refer to the rear panel of the MCD301 for the correct voltage.

Overall Dimensions

Width is 17-1/2 inches (44.45cm)

Height is 6 inches (15.24cm)

Depth is 16-1/2 inches (41.91cm)

Note: When the Disc Tray is opened, the panel clearance required in front of mounting panel is 6-3/4 inches (17.2cm).

Weight

28.2 pounds (12.8Kg) net, 44.6 pounds (20.2Kg) in shipping carton

Shipping Carton Dimensions

Width is 26-1/2 inches (67.3cm)

Depth is 24-1/4 inches (62.2cm)

Height is 11-3/4 inches (29.9cm)

NOTES

- The heavy notes on the schematic denote the primary signal path.
- Unless otherwise noted, all voltages indicated on the schematics are measured under the following conditions:
 - AC input at 120 volts, 50/60Hz.
 - All voltages are +/-10% with respect to ground. A high impedance (10 megaohm) voltmeter must be used.
- Unless otherwise specified:
 - Resistor values are in ohms.
 - Capacitor values are microfarads (uF).
 - Inductor values are in microhenries (uH).
- On PC board drawings, Square pad indicates:
 - Polarized Capacitors - Positive
 - Diodes - Cathode
 - Others - Pin 1
- WARNING**
Parts marked with the symbol  have critical characteristics. Use only replacement parts recommended by the manufacturer.
- Use McIntosh Remote Control Model HR056 with the MCD301.

SAFETY INFORMATION

CAUTION: Invisible Laser Radiation when open. DO NOT stare into the beam or view directly with optical instruments. Use of controls or adjustments or performance of procedures other than those specified in the Owners Manual may result in Hazardous Radiation Exposure.

Servicing of laser mechanism is to be performed at the service facility at McIntosh Laboratory Inc.

This product incorporates an embedded Class 3R Laser (IEC60825-1).

LUOKAN 1 LASERLAITE KLASS 1 LASER APPARAT

VAROITUS! Laitteen käyttäminen muulla kuin tassa käyttöohjeessa mainitulla tavalla saattaa altistaa käyttäjän turvallisuusluokan 1 ylittävälle näkymättömälle lasersäteilylle.

VARNING! Om apparaten används på annat sätt än i denna bruksanvisning specificerats, kan användaren utsättas för osynlig laserstrålning, som överskrider gränsen för laserklass 1.

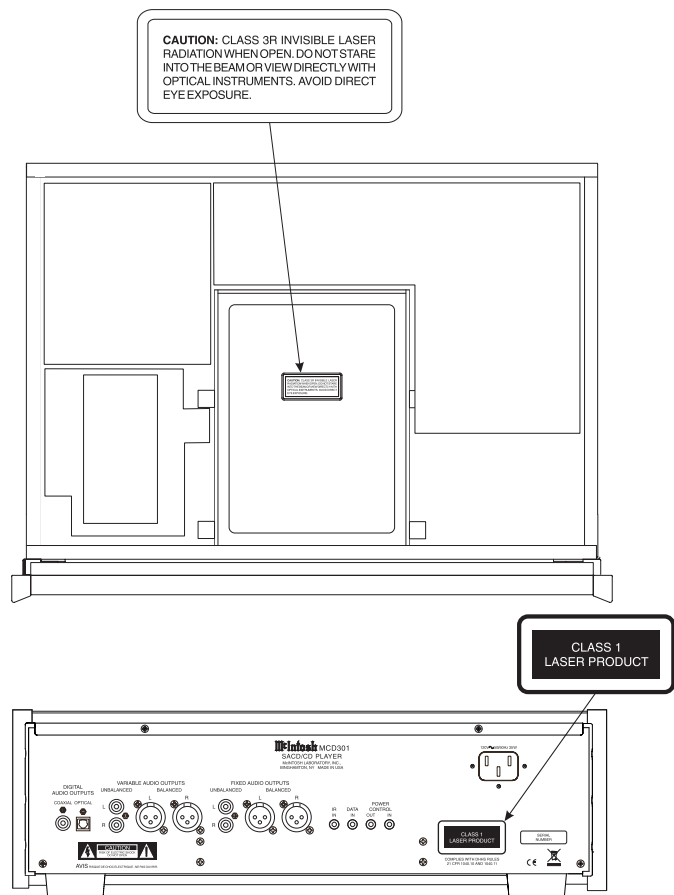

NOTES

REAR PANEL

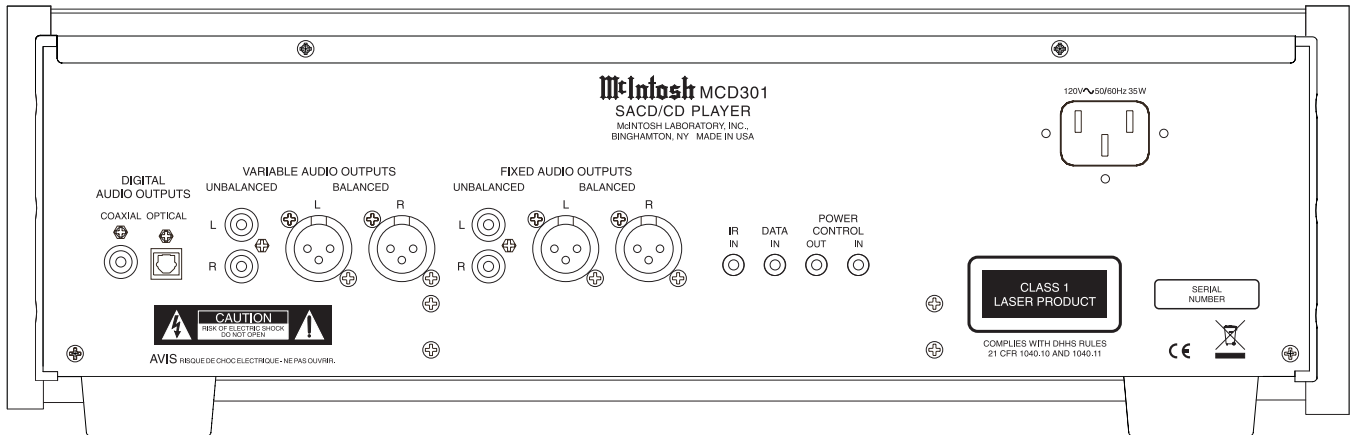

SECTION LOCATIONS

TOP VIEW WITH COVER REMOVED

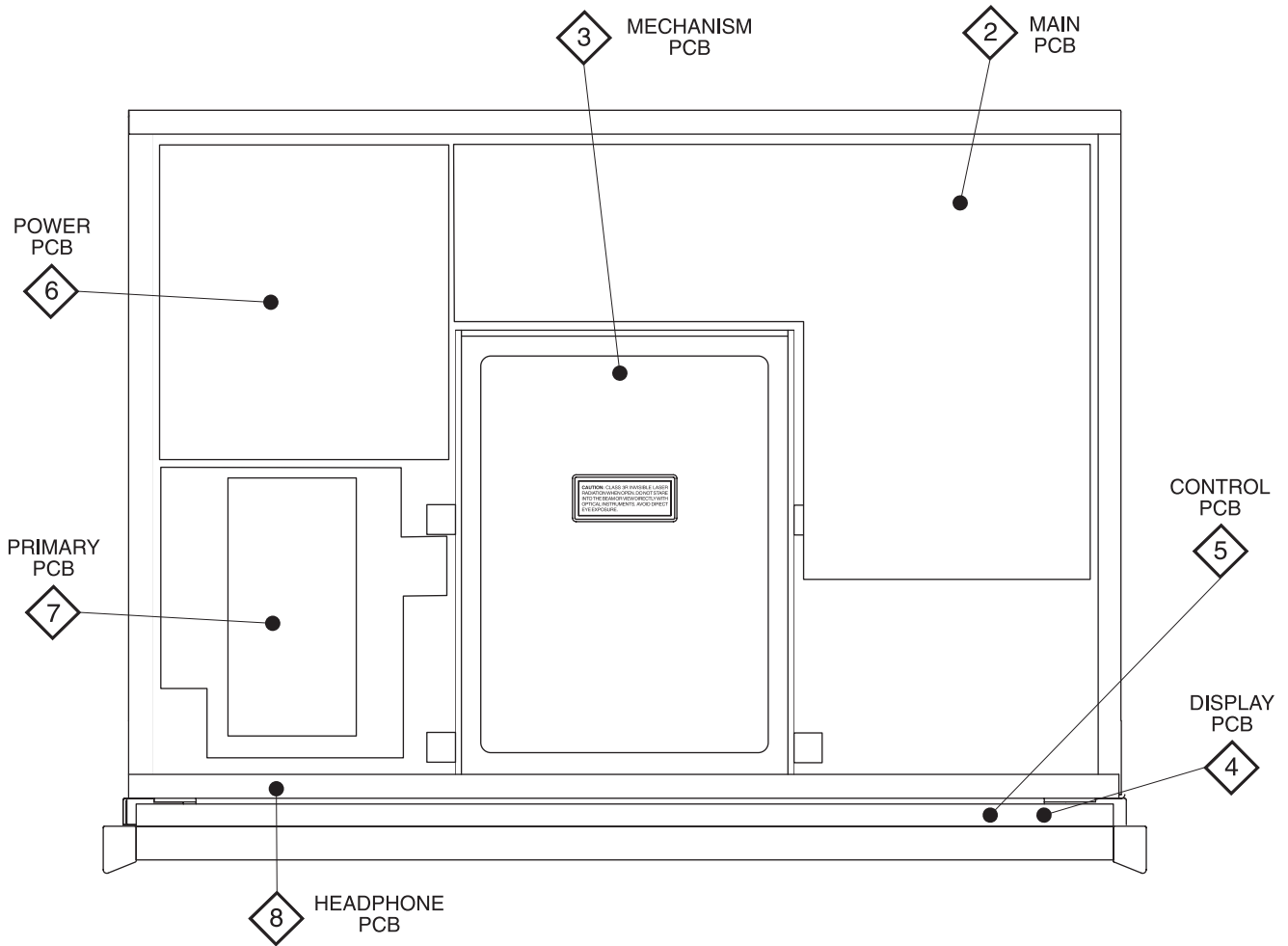

BLOCK DIAGRAM

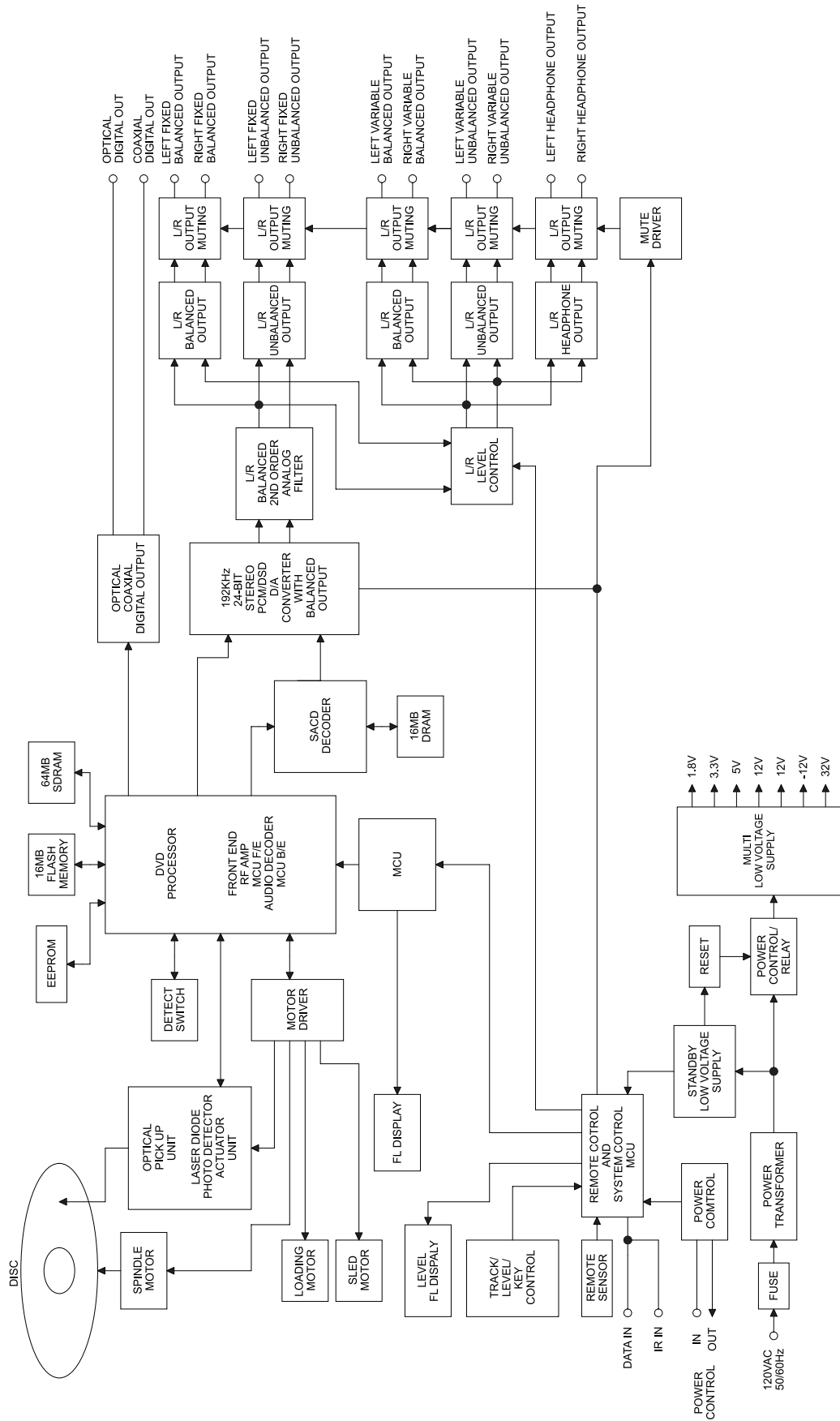

INTERCONNECT

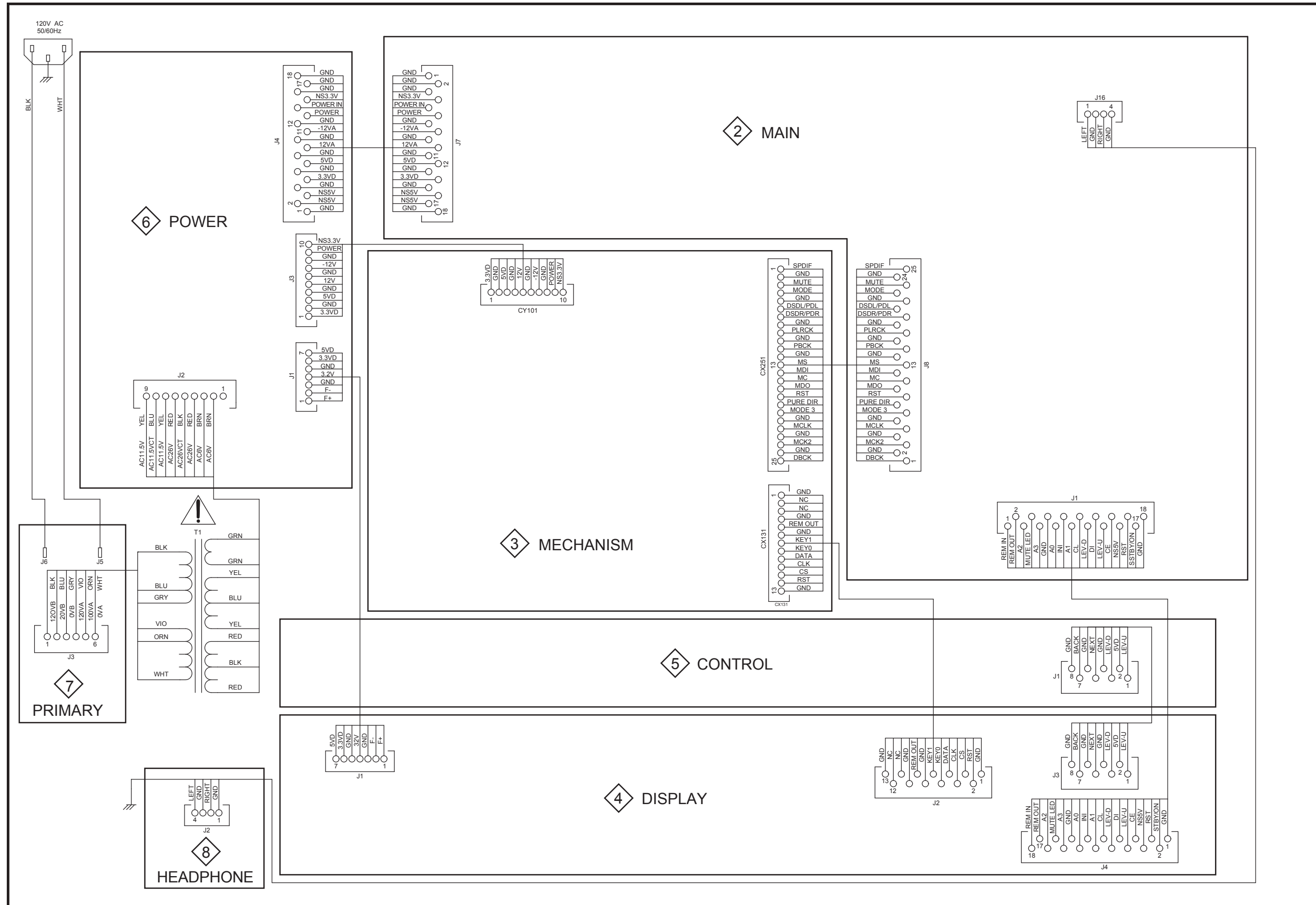

! WARNING Parts marked with a triangle and exclamation mark have critical characteristics. Use only replacement parts recommended by the manufacturer.

2 MAIN 750771 SCH 1 OF 3

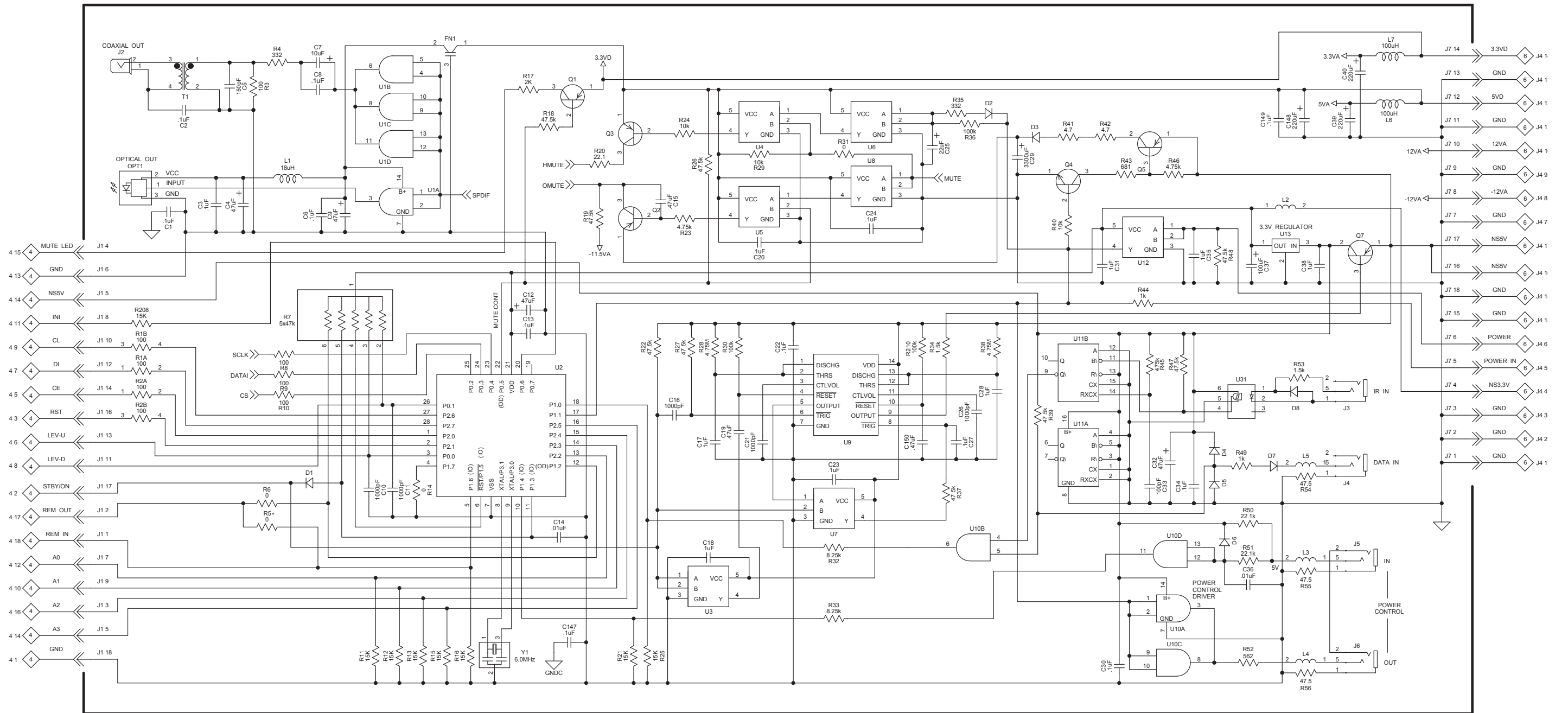

2 MAIN 750771 SCH 2 OF 3

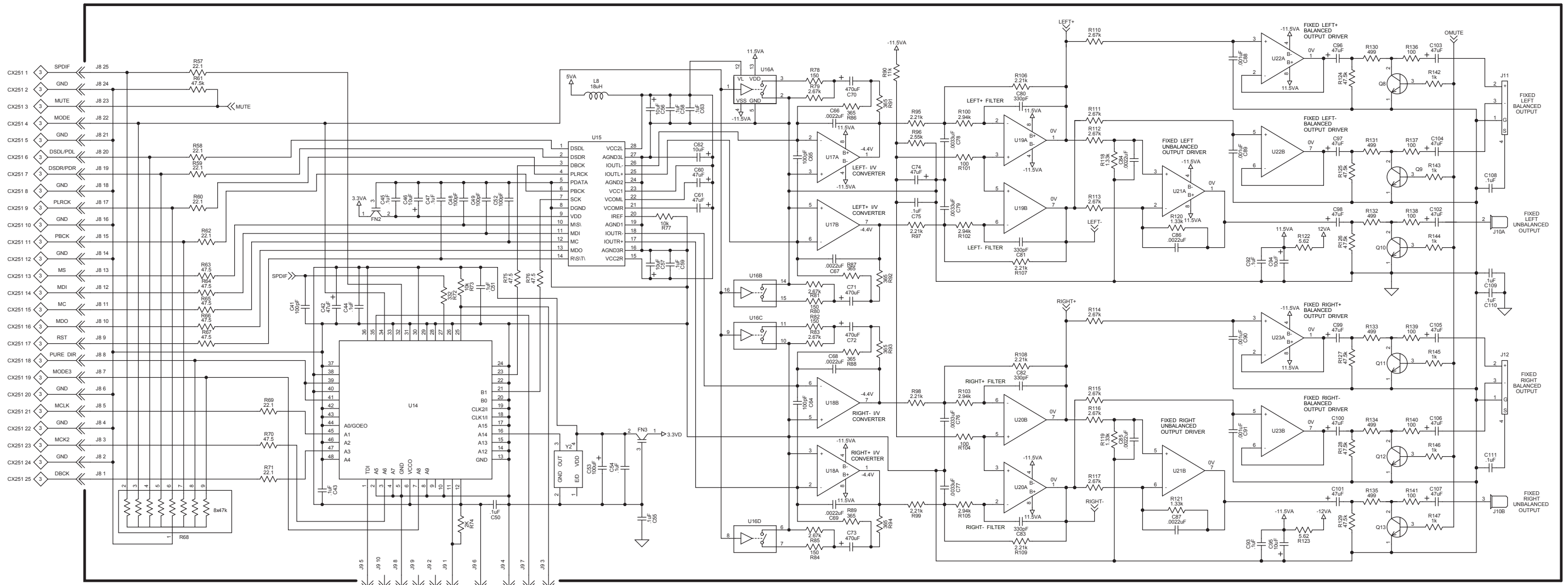

2 MAIN 750771 SCH 3 OF 3

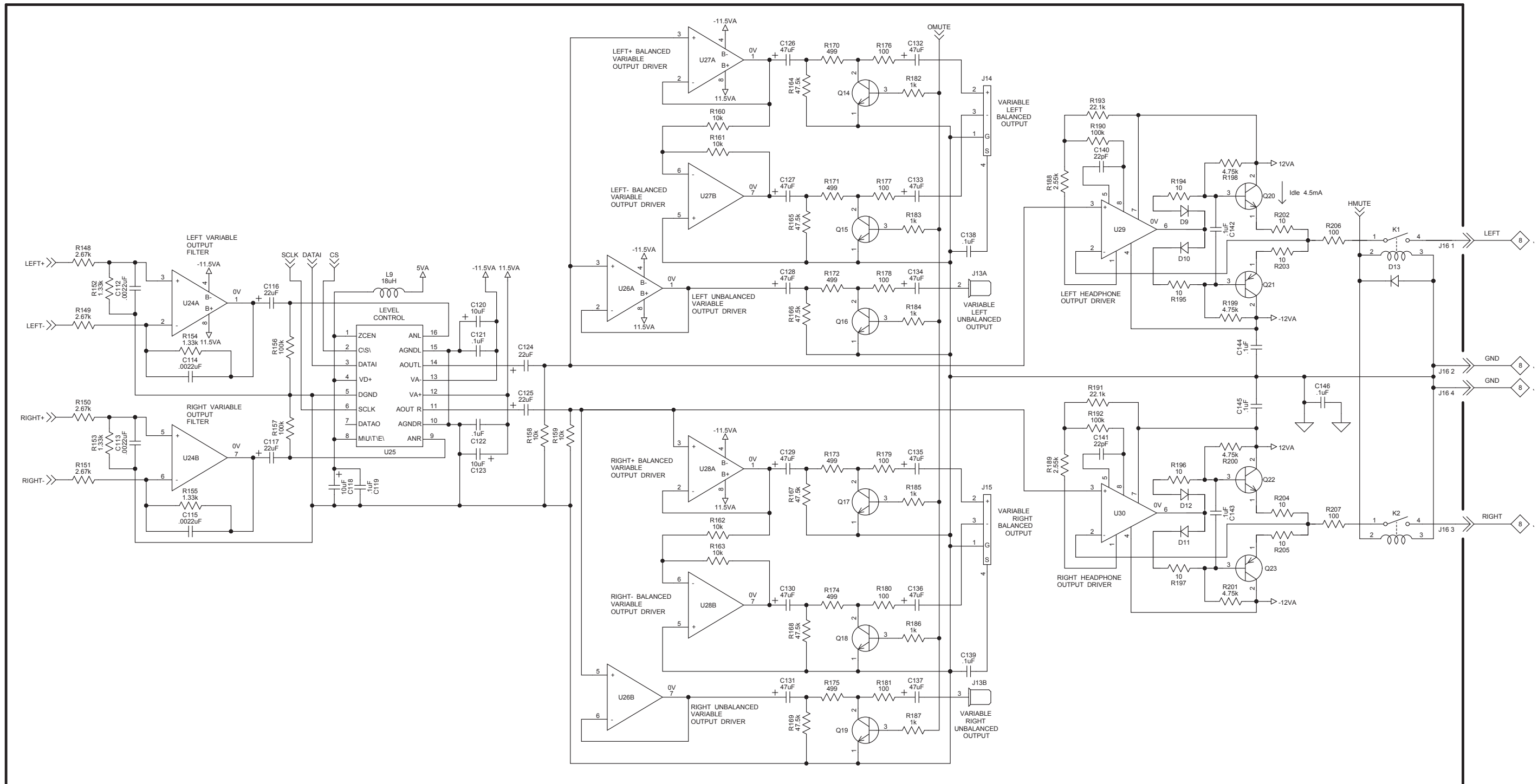

2 MAIN 750771 PCB

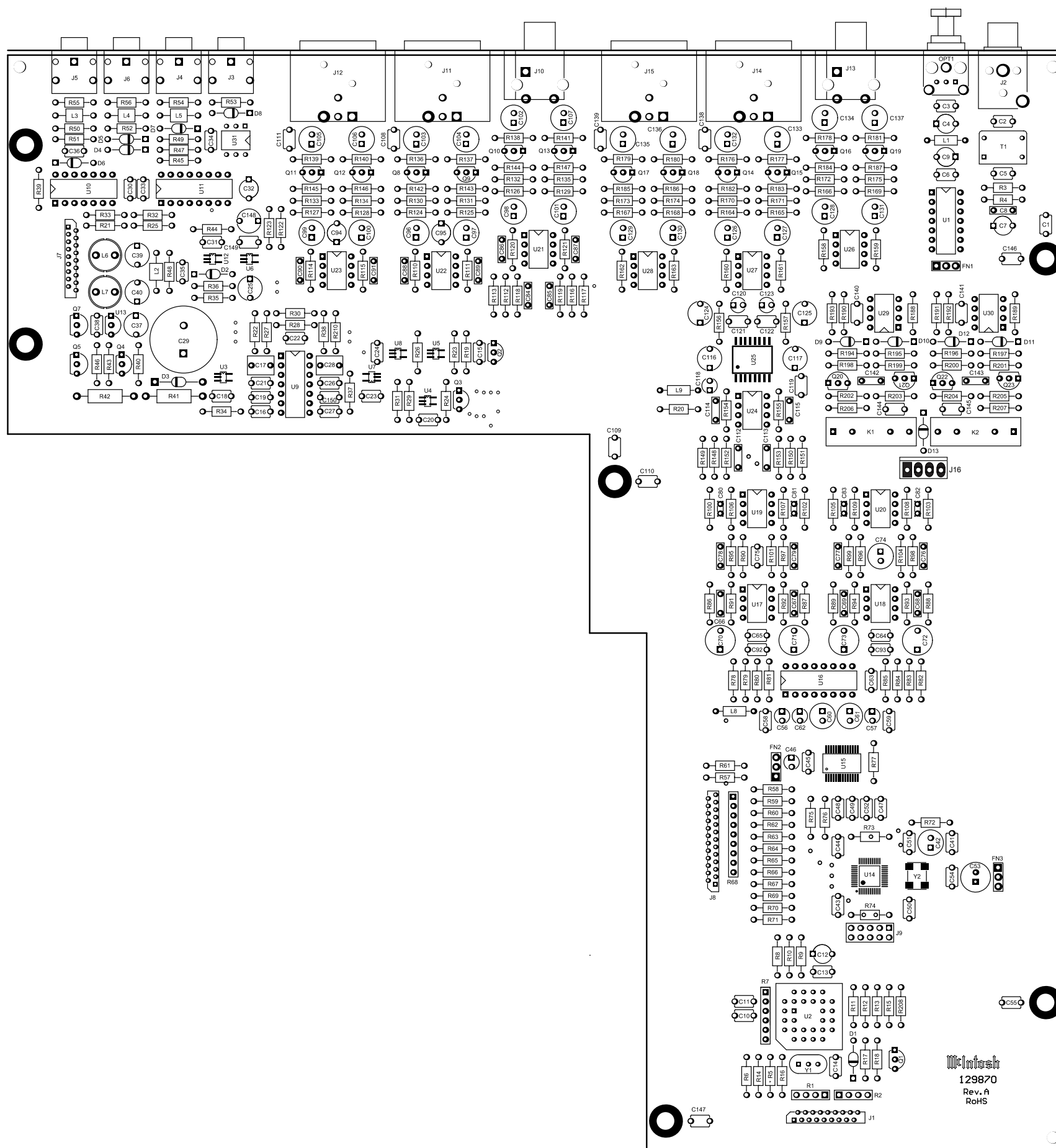

129870
Rev. A
RoHS

4 DISPLAY 750773 SCH

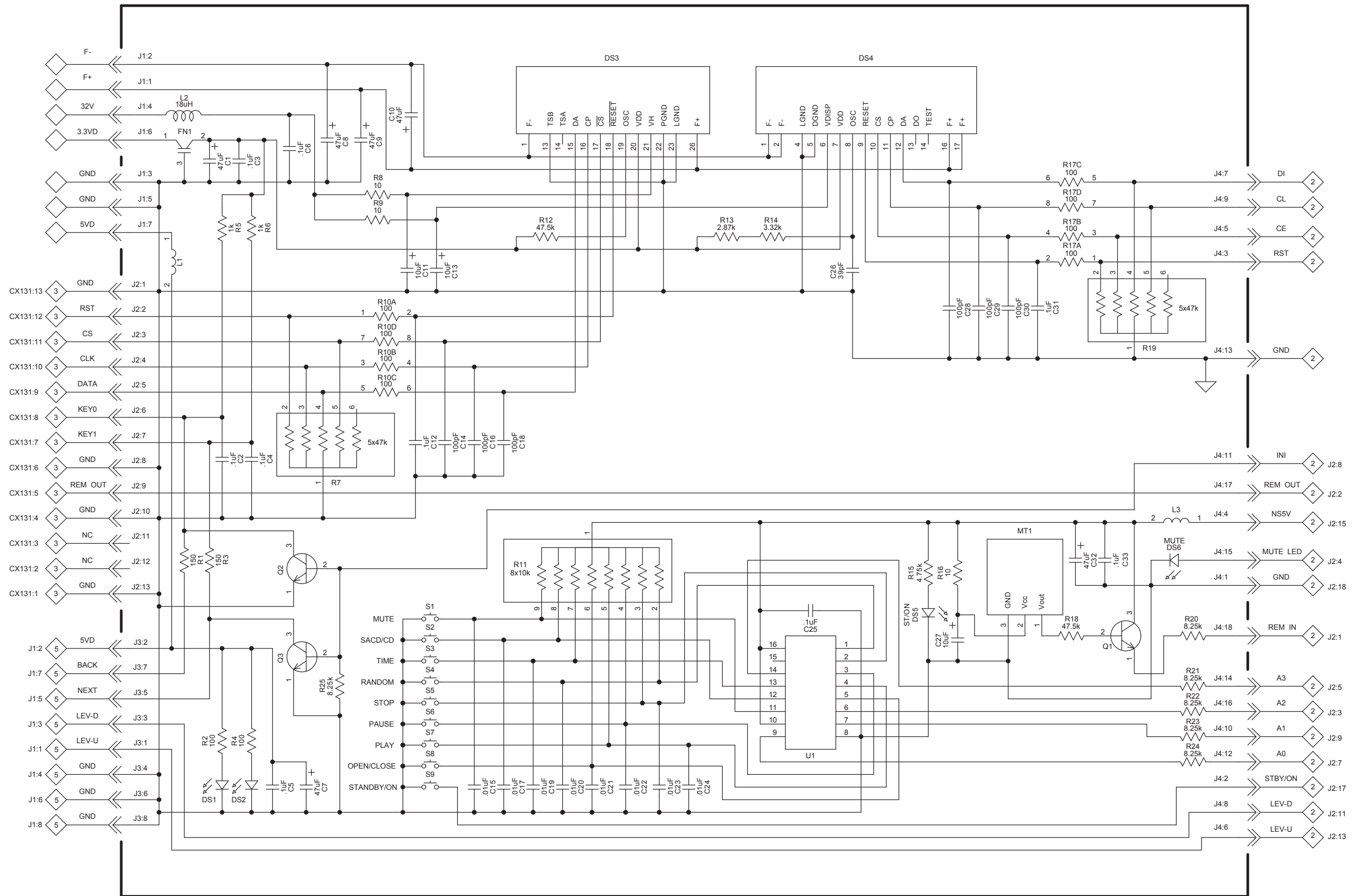

4 DISPLAY 750773 PCB

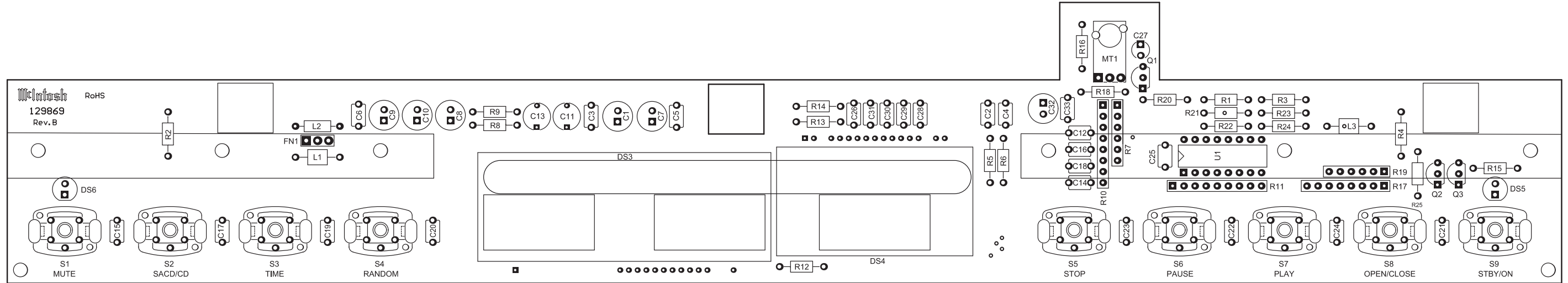

5 CONTROL 750295 SCH and PCB

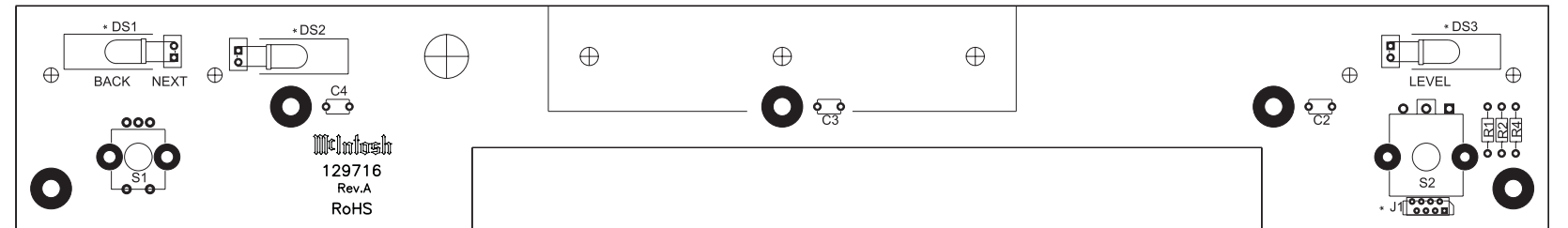
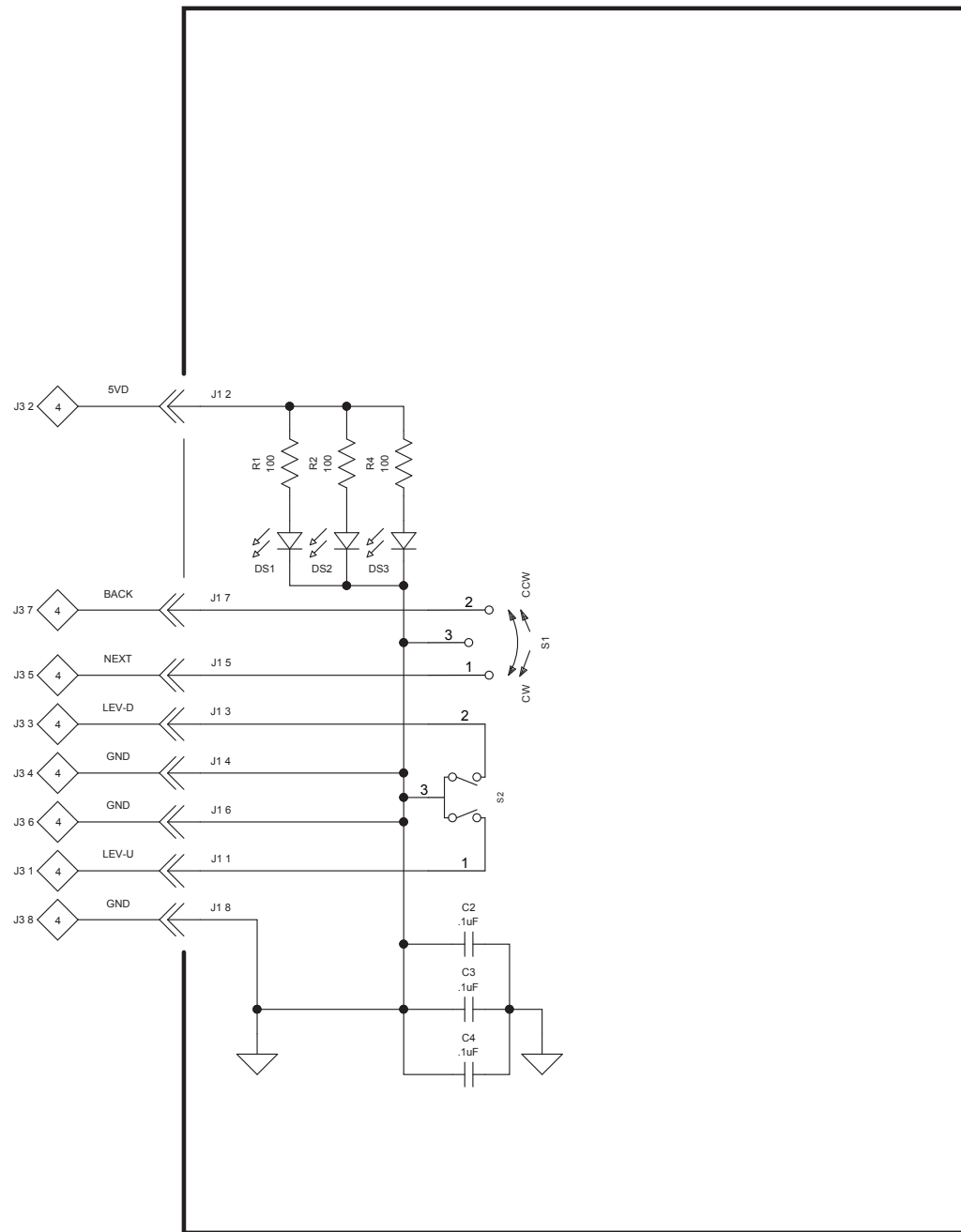

6 POWER 750772 SCH

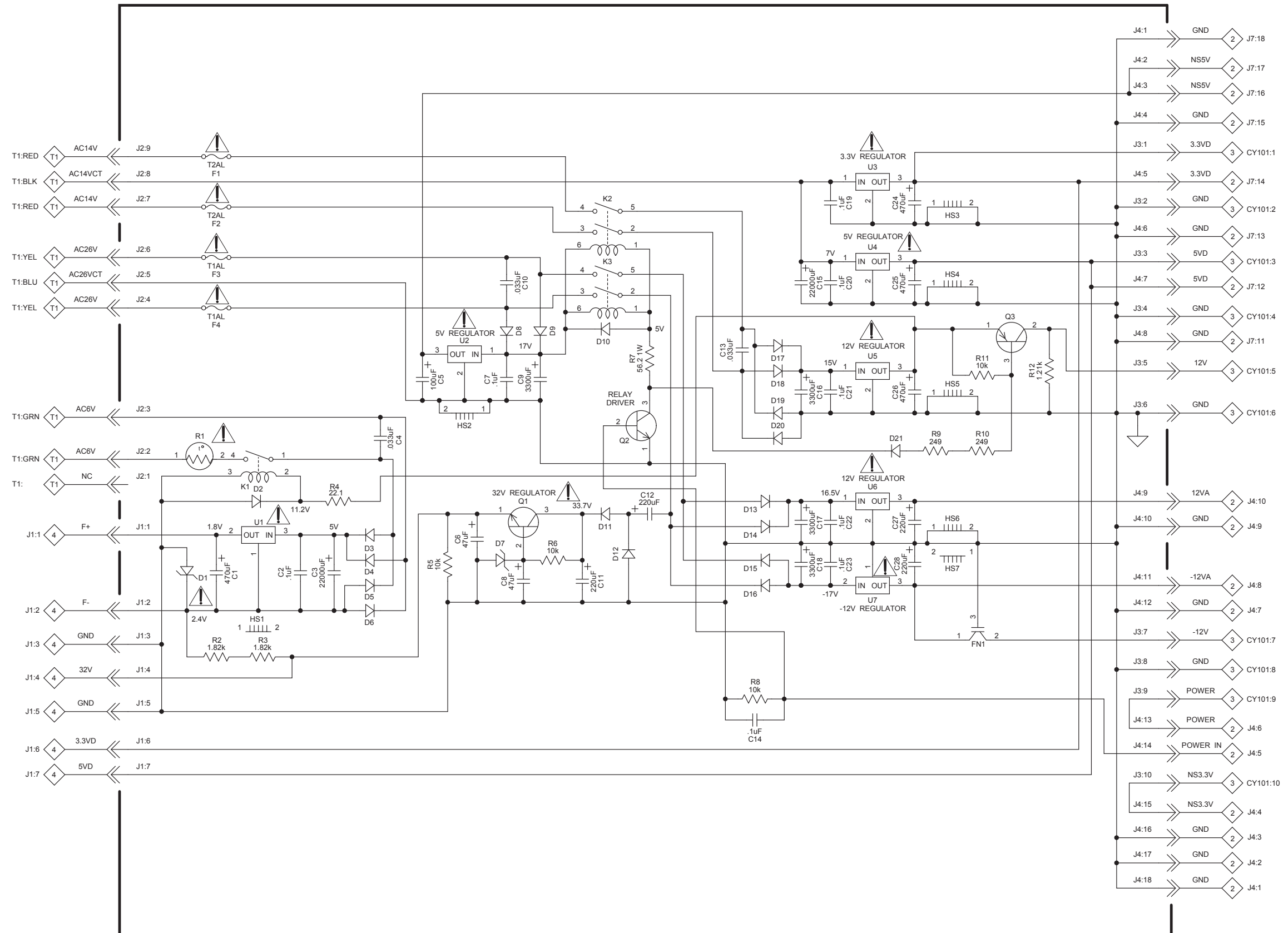

! WARNING Parts marked with a triangle and exclamation mark have critical characteristics. Use only replacement parts recommended by the manufacturer.

6 POWER 750772 PCB

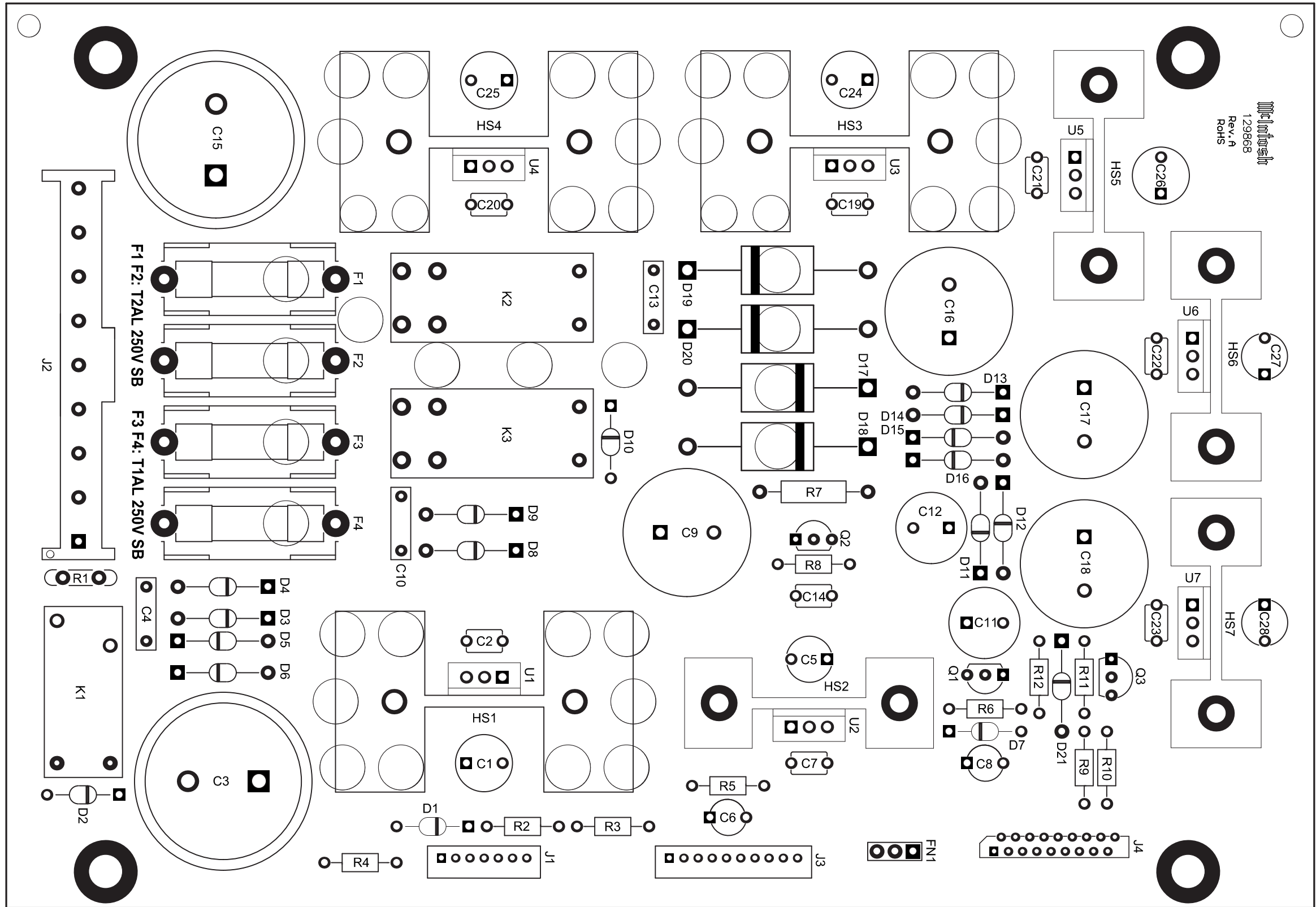

7 PRIMARY 750614 SCH and PCB

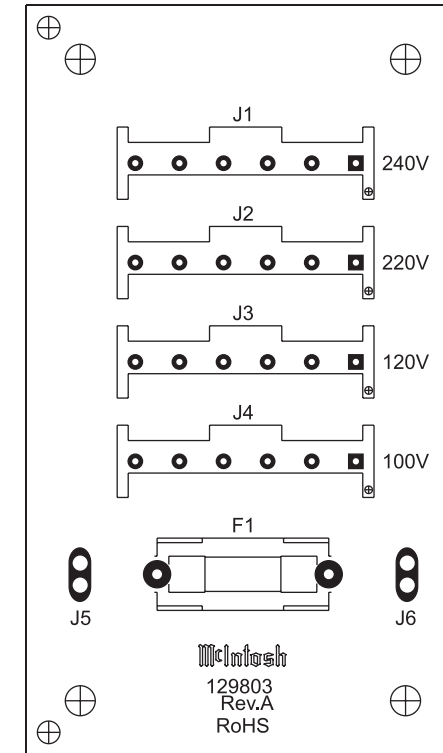
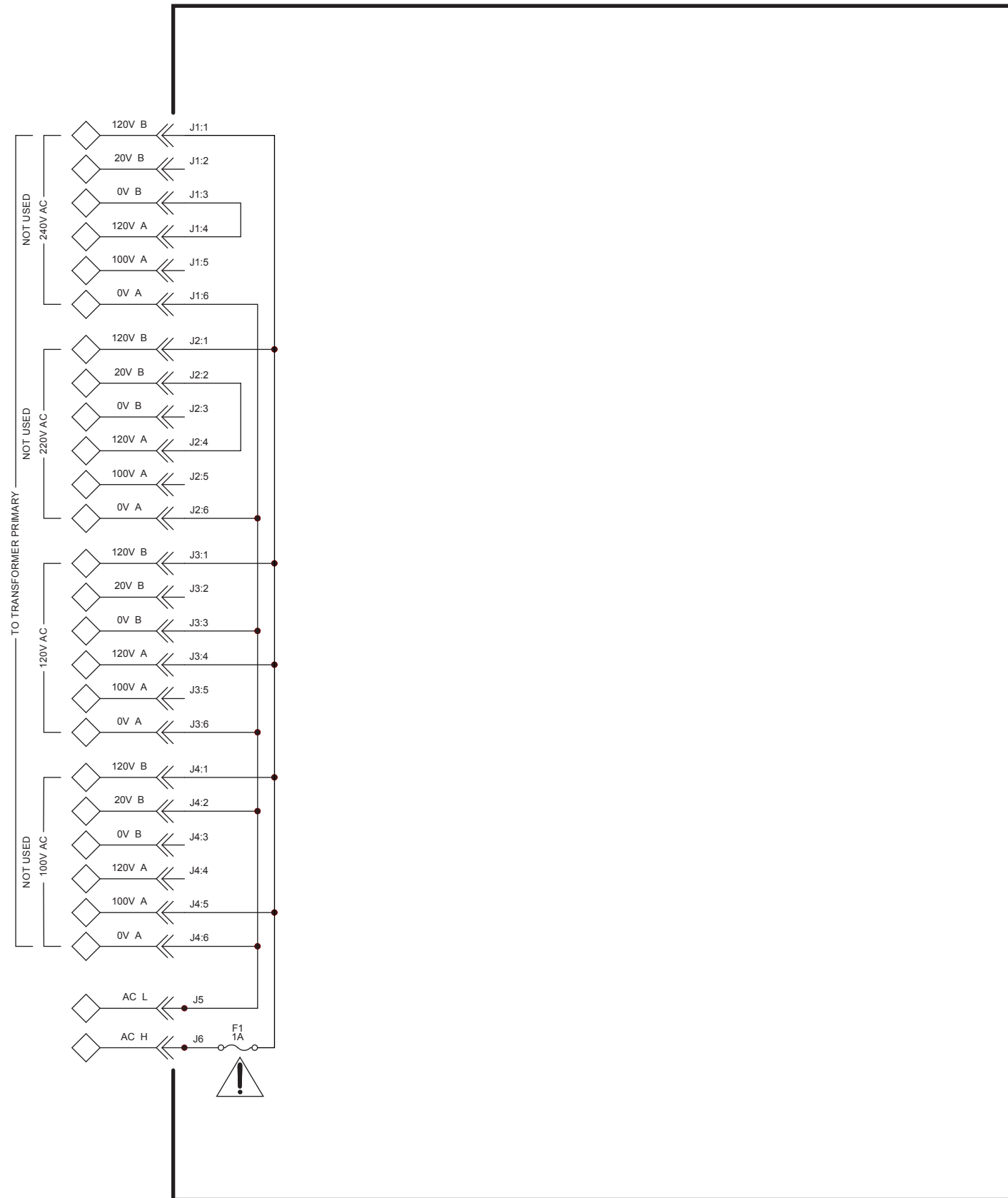

WARNING Parts marked with a triangle and exclamation mark have critical characteristics. Use only replacement parts recommended by the manufacturer.

8 HEADPHONE 750296 SCH and PCB

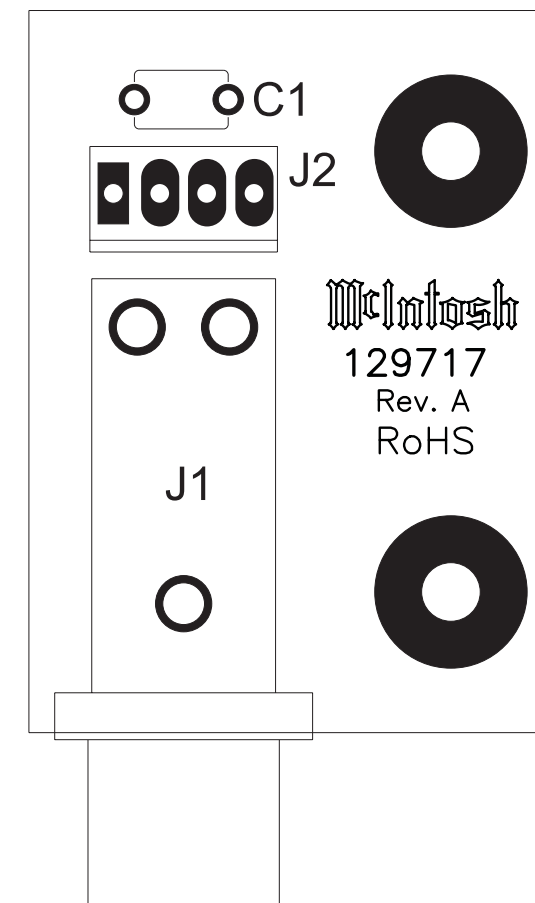
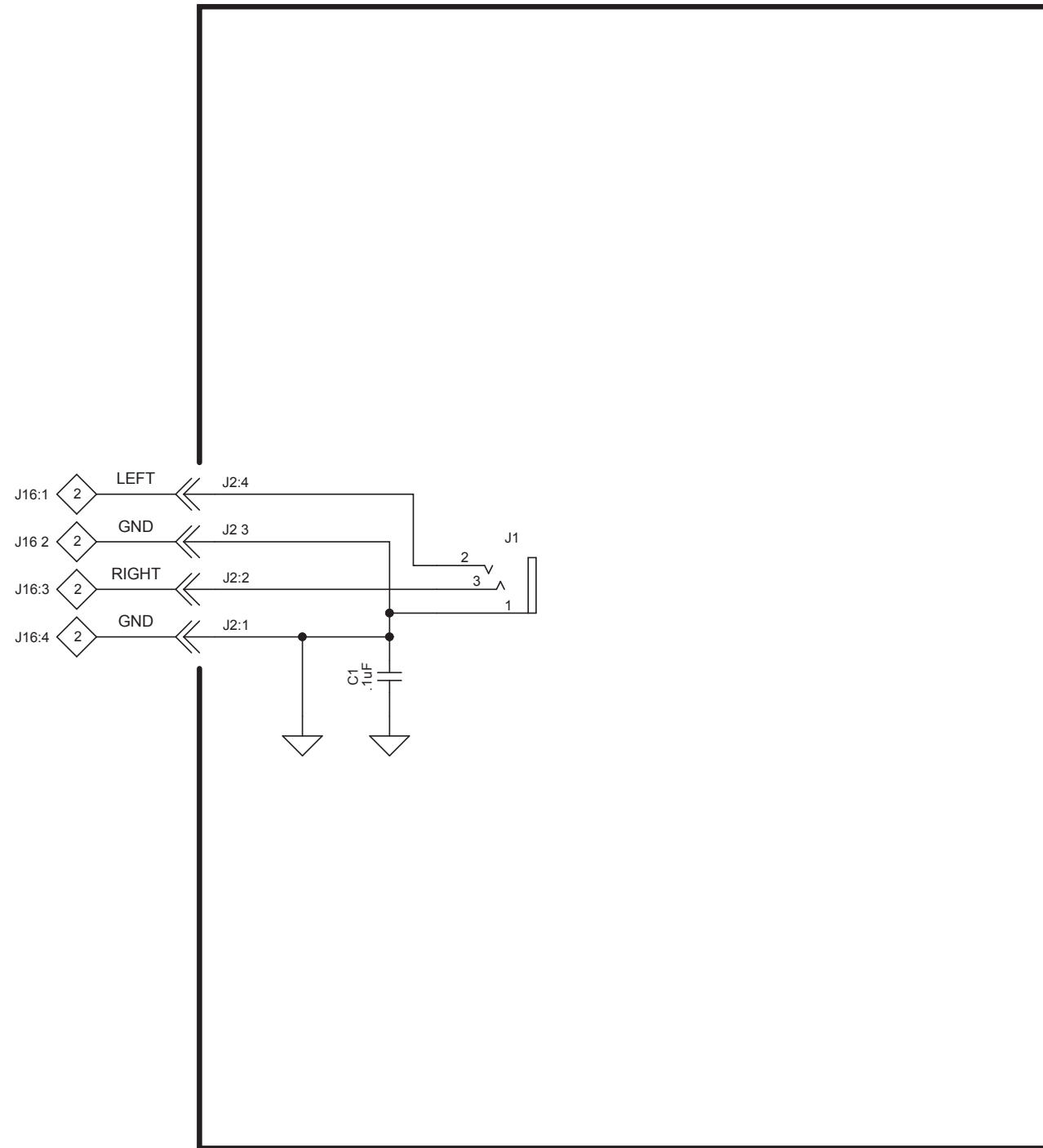

PARTS LIST

2 MAIN PCB 750771

Ref No.	Description	Part No.	Ref No.	Description	Part No.
C1	CAP MONO .1UF 50V 20% Z5U	061346	C61	CAP ELECT 47UF 16V	066380
C2	CAP MONO .1UF 50V 20% Z5U	061346	C62	CAP ELECT 10UF 16V	066580
C3	CAP MONO .1UF 50V 20% Z5U	061346	C63	CAP MONO .1UF 50V 20% Z5U	061346
C4	CAP ELECT 47UF 35V	066446	C64	CAP MONO 100PF 100V 10% NPO	061341
C5	CAP MONO 150pF 5% 200V	061349	C65	CAP MONO 100PF 100V 10% NPO	061341
C6	CAP MONO .1UF 50V 20% Z5U	061346	C66	CAP MPF 0.0022UF 5% 63VDC	064454
C7	CAP ELECT 10UF 50V	066445	C67	CAP MPF 0.0022UF 5% 63VDC	064454
C8	CAP MPF 0.1UF 5% 63VDC	064325	C68	CAP MPF 0.0022UF 5% 63VDC	064454
C9	CAP ELECT 47UF 35V	066446	C69	CAP MPF 0.0022UF 5% 63VDC	064454
C10	CAP MONO 1000PF 50V 10% NPO	061344	C70	CAP ELECT 470UF 16V	066508
C11	CAP MONO 1000PF 50V 10% NPO	061344	C71	CAP ELECT 470UF 16V	066508
C12	CAP ELECT 47UF 35V	066446	C72	CAP ELECT 470UF 16V	066508
C13	CAP MONO .1UF 50V 20% Z5U	061346	C73	CAP ELECT 470UF 16V	066508
C14	CAP MONO .01UF 50V 20%	061345	C74	CAP ELECT 47UF 16V	066380
C15	CAP DISC MONO .47UF 50V	061320	C75	CAP MONO .1UF 50V 20% Z5U	061346
C16	CAP MONO 1000PF 50V 10% NPO	061344	C76	CAP MPF 0.0033UF 5% 63VDC	064455
C17	CAP MPF 1UF 5% 63VDC	064337	C77	CAP MPF 0.0033UF 5% 63VDC	064455
C18	CAP MONO .1UF 50V 20% Z5U	061346	C78	CAP MPF 0.0033UF 5% 63VDC	064455
C19	CAP DISC MONO .47UF 50V	061320	C79	CAP MPF 0.0033UF 5% 63VDC	064455
C20	CAP MONO .1UF 50V 20% Z5U	061346	C80	CAP MONO 330PF	061332
C21	CAP MONO 1000PF 50V 10% NPO	061344	C81	CAP MONO 330PF	061332
C22	CAP MONO .1UF 50V 20% Z5U	061346	C82	CAP MONO 330PF	061332
C23	CAP MONO .1UF 50V 20% Z5U	061346	C83	CAP MONO 330PF	061332
C24	CAP MONO .1UF 50V 20% Z5U	061346	C84	CAP MPF 0.0022UF 5% 63VDC	064454
C25	CAP ELECT 22UF 100V	066574	C85	CAP MPF 0.0022UF 5% 63VDC	064454
C26	CAP MONO 1000PF 50V 10% NPO	061344	C86	CAP MPF 0.0022UF 5% 63VDC	064454
C27	CAP MONO .1UF 50V 20% Z5U	061346	C87	CAP MPF 0.0022UF 5% 63VDC	064454
C28	CAP MPF 1UF 5% 63VDC	064337	C88	CAP PF 0.001UF 5% 63VDC	064453
C29	CAP ELECT 3300UF 35V	066509	C89	CAP PF 0.001UF 5% 63VDC	064453
C30	CAP MONO .1UF 50V 20% Z5U	061346	C90	CAP PF 0.001UF 5% 63VDC	064453
C31	CAP MONO .1UF 50V 20% Z5U	061346	C91	CAP PF 0.001UF 5% 63VDC	064453
C32	CAP ELECT 47UF 35V	066446	C92	CAP MONO .1UF 50V 20% Z5U	061346
C33	CAP MONO 100PF 100V 10% NPO	061341	C93	CAP MONO .1UF 50V 20% Z5U	061346
C34	CAP MONO .1UF 50V 20% Z5U	061346	C94	CAP ELECT 10UF 50V	066445
C35	CAP MONO .1UF 50V 20% Z5U	061346	C95	CAP ELECT 10UF 50V	066445
C36	CAP MONO .01UF 50V 20%	061345	C96	CAP ELECT 47UF 16V	066380
C37	CAP ELECT 100UF 25V	066573	C97	CAP ELECT 47UF 16V	066380
C38	CAP MONO .1UF 50V 20% Z5U	061346	C98	CAP ELECT 47UF 16V	066380
C39	CAP ELECT 220UF 25V	066507	C99	CAP ELECT 47UF 16V	066380
C40	CAP ELECT 220UF 25V	066507	C100	CAP ELECT 47UF 16V	066380
C41	CAP MONO 100PF 100V 10% NPO	061341	C101	CAP ELECT 47UF 16V	066380
C42	CAP ELECT 47UF 16V	066380	C102	CAP ELECT 47UF 16V	066380
C43	CAP MONO .1UF 50V 20% Z5U	061346	C103	CAP ELECT 47UF 16V	066380
C44	CAP MONO .1UF 50V 20% Z5U	061346	C104	CAP ELECT 47UF 16V	066380
C45	CAP MONO .1UF 50V 20% Z5U	061346	C105	CAP ELECT 47UF 16V	066380
C46	CAP ELECT 10UF 16V	066580	C106	CAP ELECT 47UF 16V	066380
C47	CAP MONO .1UF 50V 20% Z5U	061346	C107	CAP ELECT 47UF 16V	066380
C48	CAP MONO 100PF 100V 10% NPO	061341	C108	CAP MONO .1UF 50V 20% Z5U	061346
C49	CAP MONO 100PF 100V 10% NPO	061341	C109	CAP MONO .1UF 50V 20% Z5U	061346
C50	CAP MONO .1UF 50V 20% Z5U	061346	C110	CAP MONO .1UF 50V 20% Z5U	061346
C51	CAP MONO .1UF 50V 20% Z5U	061346	C111	CAP MONO .1UF 50V 20% Z5U	061346
C52	CAP MONO 100PF 100V 10% NPO	061341	C112	CAP MPF 0.0022UF 5% 63VDC	064454
C53	CAP ELECT 100UF 16V 5MM	066576	C113	CAP MPF 0.0022UF 5% 63VDC	064454
C54	CAP MONO .1UF 50V 20% Z5U	061346	C114	CAP MPF 0.0022UF 5% 63VDC	064454
C55	CAP MONO .1UF 50V 20% Z5U	061346	C115	CAP MPF 0.0022UF 5% 63VDC	064454
C56	CAP ELECT 10UF 16V	066580	C116	CAP ELECT 22UF 100V	066574
C57	CAP ELECT 10UF 16V	066580	C117	CAP ELECT 22UF 100V	066574
C58	CAP MONO .1UF 50V 20% Z5U	061346	C118	CAP ELECT 10UF 16V	066580
C59	CAP MONO .1UF 50V 20% Z5U	061346	C119	CAP MONO .1UF 50V 20% Z5U	061346
C60	CAP ELECT 47UF 16V	066380	C120	CAP ELECT 10UF 16V	066580
			C121	CAP MONO .1UF 50V 20% Z5U	061346
			C122	CAP MONO .1UF 50V 20% Z5U	061346
			C123	CAP ELECT 10UF 16V	066580
			C124	CAP ELECT 22UF 100V	066574

PARTS LIST *con't*

MAIN PCB 750771 (cont'd)

Ref No.	Description	Part No.	Ref No.	Description	Part No.
C125	CAP ELECT 22UF 100V	066574	L1	CHOKE 18UH 5%-10%	122394
C126	CAP ELECT 47UF 16V	066380	L2	BEADS FERRITE LEADED	076023
C127	CAP ELECT 47UF 16V	066380	L3	BEADS FERRITE LEADED	076023
C128	CAP ELECT 47UF 16V	066380	L4	BEADS FERRITE LEADED	076023
C129	CAP ELECT 47UF 16V	066380	L5	BEADS FERRITE LEADED	076023
C130	CAP ELECT 47UF 16V	066380	L6	INDUCTOR 100UH POWER	122406
C131	CAP ELECT 47UF 16V	066380	L7	INDUCTOR 100UH POWER	122406
C132	CAP ELECT 47UF 16V	066380	L8	CHOKE 18UH 5%-10%	122394
C133	CAP ELECT 47UF 16V	066380	L9	CHOKE 18UH 5%-10%	122394
C134	CAP ELECT 47UF 16V	066380	OPT1	TRANSMITTER FIBER OPTIC	058180
C135	CAP ELECT 47UF 16V	066380	PCB1	PC BD MAIN	129870
C136	CAP ELECT 47UF 16V	066380	Q1	TRANSISTOR PNP SILICON	132304
C137	CAP ELECT 47UF 16V	066380	Q2	TRANSISTOR PNP SILICON	132304
C138	CAP MONO .1UF 50V 20% Z5U	061346	Q3	TRANSISTOR PNP SILICON	132304
C139	CAP MONO .1UF 50V 20% Z5U	061346	Q4	TRANSISTOR NPN SILICON	132317
C140	CAP MONO 22PF 200V 10% NPO	061339	Q5	TRANSISTOR PNP	132263
C141	CAP MONO 22PF 200V 10% NPO	061339	Q7	TRANSISTOR PNP	132263
C142	CAP MPF 0.1UF 5% 63VDC	064325	Q8	TRANSISTOR NPN	132257
C143	CAP MPF 0.1UF 5% 63VDC	064325	Q9	TRANSISTOR NPN	132257
C144	CAP MONO .1UF 50V 20% Z5U	061346	Q10	TRANSISTOR NPN	132257
C145	CAP MONO .1UF 50V 20% Z5U	061346	Q11	TRANSISTOR NPN	132257
C146	CAP MONO .1UF 50V 20% Z5U	061346	Q12	TRANSISTOR NPN	132257
C147	CAP MONO .1UF 50V 20% Z5U	061346	Q13	TRANSISTOR NPN	132257
C148	CAP ELECT 220UF 25V	066507	Q14	TRANSISTOR NPN	132257
C149	CAP MONO .1UF 50V 20% Z5U	061346	Q15	TRANSISTOR NPN	132257
C150	CAP MONO .47UF 50V	061320	Q16	TRANSISTOR NPN	132257
D1	DIODE SILICON	070174	Q17	TRANSISTOR NPN	132257
D2	DIODE SILICON	070174	Q18	TRANSISTOR NPN	132257
D3	DIODE SIL 400 PIV @ 1.5A	070031	Q19	TRANSISTOR NPN	132257
D4	DIODE SILICON	070174	Q20	TRANSISTOR NPN 2A 50V	132302
D5	DIODE SILICON	070174	Q21	TRANSISTOR PNP	132263
D6	DIODE SILICON	070174	Q22	TRANSISTOR NPN 2A 50V	132302
D7	DIODE SILICON	070174	Q23	TRANSISTOR PNP	132263
D8	DIODE SILICON	070174	R1	RES NETWORK 2X100 OHM ISOLATED	144680
D9	DIODE SILICON	070174	R2	RES NETWORK 2X100 OHM ISOLATED	144680
D10	DIODE SILICON	070174	R3	RES MF 100 OHM 1% 1/4W	144568
D11	DIODE SILICON	070174	R4	RES MF 332 OHM 1% 1/4W	144646
D12	DIODE SILICON	070174	R5	RES CF 0 OHM 5% 1/4W	141554
D13	DIODE SILICON	070174	R6	RES CF 0 OHM 5% 1/4W	141554
FN1	FILTER EMI	180057	R7	RES NETWORK 5X47K BUSSED	144499
FN2	FILTER EMI	180057	R8	RES MF 100 OHM 1% 1/4W	144568
FN3	FILTER EMI	180057	R9	RES MF 100 OHM 1% 1/4W	144568
J1	CONN FFC 18PIN	117908	R10	RES MF 100 OHM 1% 1/4W	144568
J2	JACK RCA ORANGE WITH GOLD	117798	R11	RES MF 15K 1% 1/4W	144623
J3	JACK HEADPHONE STEREO 1/8IN	117945	R12	RES MF 15K 1% 1/4W	144623
J4	JACK HEADPHONE STEREO 1/8IN	117945	R13	RES MF 15K 1% 1/4W	144623
J5	JACK HEADPHONE STEREO 1/8IN	117945	R14	RES CF 0 OHM 5% 1/4W	141554
J6	JACK HEADPHONE STEREO 1/8IN	117945	R15	RES MF 15K 1% 1/4W	144623
J7	CONN FFC 18PIN	117908	R16	RES MF 15K 1% 1/4W	144623
J8	CONN 25 PIN FFC	117974	R17	RES MF 2K 1% 1/4W	144517
J9	10 PIN HEADER	117829	R18	RES MF 47.5K 1% 1/4W	144526
J16	CONN 4 PIN	117215	R19	RES MF 47.5K 1% 1/4W	144526
J10	JACK RCA 1X2 WHT/RED 14MM	117788	R20	RES MF 22.1 OHM 1% 1/4W	144554
J11	RECEPTACLE XLR MALE	117686	R21	RES MF 15K 1% 1/4W	144623
J12	RECEPTACLE XLR MALE	117686	R22	RES MF 47.5K 1% 1/4W	144526
J13	JACK RCA 1X2 WHT/RED 14MM	117788	R23	RES MF 4.75K 1% 1/4W	144520
J14	RECEPTACLE XLR MALE	117686	R24	RES MF 10K 1% 1/4W	144504
J15	RECEPTACLE XLR MALE	117686	R25	RES MF 15K 1% 1/4W	144623
K1	RELAY REED FORM 1A 5V 500 OHMS	087050	R26	RES MF 47.5K 1% 1/4W	144526
K2	RELAY REED FORM 1A 5V 500 OHMS	087050	R27	RES MF 47.5K 1% 1/4W	144526
			R28	RES MF 4.75M 1% 1/4W	144608
			R29	RES MF 10K 1% 1/4W	144504
			R30	RES MF 100K 1% 1/4W	144528
			R31	RES CF 0 OHM 5% 1/4W	141554

PARTS LIST *con't*

MAIN PCB 750771 (cont'd)

Ref No.	Description	Part No.	Ref No.	Description	Part No.
R32	RES MF 8.25K 1% 1/4W	144549	R92	RES MF 365 OHM 1% 1/4W	144505
R33	RES MF 8.25K 1% 1/4W	144549	R93	RES MF 365 OHM 1% 1/4W	144505
R34	RES MF 1.5K 1% 1/4W	144539	R94	RES MF 365 OHM 1% 1/4W	144505
R35	RES MF 332 OHM 1% 1/4W	144646	R95	RES MF 2.21K 1% 1/4W	144584
R36	RES MF 100K 1% 1/4W	144528	R96	RES MF 2.55K 1% 1/4W	144734
R37	RES MF 47.5K 1% 1/4W	144526	R97	RES MF 2.21K 1% 1/4W	144584
R38	RES MF 4.75M 1% 1/4W	144608	R98	RES MF 2.21K 1% 1/4W	144584
R39	RES MF 47.5K 1% 1/4W	144526	R99	RES MF 2.21K 1% 1/4W	144584
R40	RES MF 10K 1% 1/4W	144504	R100	RES MF 2.94K 1% 1/4W	144667
R41	RES MO 4.7 OHM 5% 1W	144656	R101	RES MF 100 OHM 1% 1/4W	144568
R42	RES MO 4.7 OHM 5% 1W	144656	R102	RES MF 2.94K 1% 1/4W	144667
R43	RES MF 681 OHM 1% 1/4W	144567	R103	RES MF 2.94K 1% 1/4W	144667
R44	RES MF 1K 1% 1/4W	144513	R104	RES MF 100 OHM 1% 1/4W	144568
R45	RES MF 475K 1% 1/4W	144604	R105	RES MF 2.94K 1% 1/4W	144667
R46	RES MF 4.75K 1% 1/4W	144520	R106	RES MF 2.21K 1% 1/4W	144584
R47	RES MF 47.5K 1% 1/4W	144526	R107	RES MF 2.21K 1% 1/4W	144584
R48	RES MF 47.5K 1% 1/4W	144526	R108	RES MF 2.21K 1% 1/4W	144584
R49	RES MF 1K 1% 1/4W	144513	R109	RES MF 2.21K 1% 1/4W	144584
R50	RES MF 22.1K 1% 1/4W	144564	R110	RES MF 2.67K 1% 1/4W	144534
R51	RES MF 22.1K 1% 1/4W	144564	R111	RES MF 2.67K 1% 1/4W	144534
R52	RES MF 562 OHM 1% 1/4W	144622	R112	RES MF 2.67K 1% 1/4W	144534
R53	RES MF 1.5K 1% 1/4W	144539	R113	RES MF 2.67K 1% 1/4W	144534
R54	RES MF 47.5 OHM 1% 1/4W	144642	R114	RES MF 2.67K 1% 1/4W	144534
R55	RES MF 47.5 OHM 1% 1/4W	144642	R115	RES MF 2.67K 1% 1/4W	144534
R56	RES MF 47.5 OHM 1% 1/4W	144642	R116	RES MF 2.67K 1% 1/4W	144534
R57	RES MF 22.1 OHM 1% 1/4W	144554	R117	RES MF 2.67K 1% 1/4W	144534
R58	RES MF 22.1 OHM 1% 1/4W	144554	R118	RES MF 1.33K 1% 1/4W	144619
R59	RES MF 22.1 OHM 1% 1/4W	144554	R119	RES MF 1.33K 1% 1/4W	144619
R60	RES MF 22.1 OHM 1% 1/4W	144554	R120	RES MF 1.33K 1% 1/4W	144619
R61	RES MF 47.5K 1% 1/4W	144526	R121	RES MF 1.33K 1% 1/4W	144619
R62	RES MF 22.1 OHM 1% 1/4W	144554	R122	RES MF 5.62OHM 1% 1/4W	144556
R63	RES MF 47.5 OHM 1% 1/4W	144642	R123	RES MF 5.62OHM 1% 1/4W	144556
R64	RES MF 47.5 OHM 1% 1/4W	144642	R124	RES MF 47.5K 1% 1/4W	144526
R65	RES MF 47.5 OHM 1% 1/4W	144642	R125	RES MF 47.5K 1% 1/4W	144526
R66	RES MF 47.5 OHM 1% 1/4W	144642	R126	RES MF 47.5K 1% 1/4W	144526
R67	RES MF 47.5 OHM 1% 1/4W	144642	R127	RES MF 47.5K 1% 1/4W	144526
R68	RES NETWORK 9 X 47K BUS	144673	R128	RES MF 47.5K 1% 1/4W	144526
R69	RES MF 22.1 OHM 1% 1/4W	144554	R129	RES MF 47.5K 1% 1/4W	144526
R70	RES MF 47.5 OHM 1% 1/4W	144642	R130	RES MF 499 OHM 1% 1/4W	144510
R71	RES MF 22.1 OHM 1% 1/4W	144554	R131	RES MF 499 OHM 1% 1/4W	144510
R72	RES MF 332 OHM 1% 1/4W	144646	R132	RES MF 499 OHM 1% 1/4W	144510
R73	RES MF 10K 1% 1/4W	144504	R133	RES MF 499 OHM 1% 1/4W	144510
R74	RES MF 2K 1% 1/4W	144517	R134	RES MF 499 OHM 1% 1/4W	144510
R75	RES MF 47.5 OHM 1% 1/4W	144642	R135	RES MF 499 OHM 1% 1/4W	144510
R76	RES MF 47.5 OHM 1% 1/4W	144642	R136	RES MF 100 OHM 1% 1/4W	144568
R77	RES MF 10K 1% 1/4W	144504	R137	RES MF 100 OHM 1% 1/4W	144568
R78	RES MF 150 OHM 1% 1/4W	144535	R138	RES MF 100 OHM 1% 1/4W	144568
R79	RES MF 2.67K 1% 1/4W	144534	R139	RES MF 100 OHM 1% 1/4W	144568
R80	RES MF 150 OHM 1% 1/4W	144535	R140	RES MF 100 OHM 1% 1/4W	144568
R81	RES MF 2.67K 1% 1/4W	144534	R141	RES MF 100 OHM 1% 1/4W	144568
R82	RES MF 150 OHM 1% 1/4W	144535	R142	RES MF 1K 1% 1/4W	144513
R83	RES MF 2.67K 1% 1/4W	144534	R143	RES MF 1K 1% 1/4W	144513
R84	RES MF 150 OHM 1% 1/4W	144535	R144	RES MF 1K 1% 1/4W	144513
R85	RES MF 2.67K 1% 1/4W	144534	R145	RES MF 1K 1% 1/4W	144513
R86	RES MF 365 OHM 1% 1/4W	144505	R146	RES MF 1K 1% 1/4W	144513
R87	RES MF 365 OHM 1% 1/4W	144505	R147	RES MF 1K 1% 1/4W	144513
R88	RES MF 365 OHM 1% 1/4W	144505	R148	RES MF 2.67K 1% 1/4W	144534
R89	RES MF 365 OHM 1% 1/4W	144505	R149	RES MF 2.67K 1% 1/4W	144534
R90	RES MF 11K 1% 1/4W	144523	R150	RES MF 2.67K 1% 1/4W	144534
R91	RES MF 365 OHM 1% 1/4W	144505	R151	RES MF 2.67K 1% 1/4W	144534
			R152	RES MF 1.33K 1% 1/4W	144619
			R153	RES MF 1.33K 1% 1/4W	144619
			R154	RES MF 1.33K 1% 1/4W	144619

PARTS LIST *con't*

MAIN PCB 750771 (cont'd)

Ref No.	Description	Part No.
R155	RES MF 1.33K 1% 1/4W	144619
R156	RES MF 100K 1% 1/4W	144528
R157	RES MF 100K 1% 1/4W	144528
R158	RES MF 10K 1% 1/4W	144504
R159	RES MF 10K 1% 1/4W	144504
R160	RES MF 10K 1% 1/4W	144504
R161	RES MF 10K 1% 1/4W	144504
R162	RES MF 10K 1% 1/4W	144504
R163	RES MF 10K 1% 1/4W	144504
R164	RES MF 47.5K 1% 1/4W	144526
R165	RES MF 47.5K 1% 1/4W	144526
R166	RES MF 47.5K 1% 1/4W	144526
R167	RES MF 47.5K 1% 1/4W	144526
R168	RES MF 47.5K 1% 1/4W	144526
R169	RES MF 47.5K 1% 1/4W	144526
R170	RES MF 499 OHM 1% 1/4W	144510
R171	RES MF 499 OHM 1% 1/4W	144510
R172	RES MF 499 OHM 1% 1/4W	144510
R173	RES MF 499 OHM 1% 1/4W	144510
R174	RES MF 499 OHM 1% 1/4W	144510
R175	RES MF 499 OHM 1% 1/4W	144510
R176	RES MF 100 OHM 1% 1/4W	144568
R177	RES MF 100 OHM 1% 1/4W	144568
R178	RES MF 100 OHM 1% 1/4W	144568
R179	RES MF 100 OHM 1% 1/4W	144568
R180	RES MF 100 OHM 1% 1/4W	144568
R181	RES MF 100 OHM 1% 1/4W	144568
R182	RES MF 1K 1% 1/4W	144513
R183	RES MF 1K 1% 1/4W	144513
R184	RES MF 1K 1% 1/4W	144513
R185	RES MF 1K 1% 1/4W	144513
R186	RES MF 1K 1% 1/4W	144513
R187	RES MF 1K 1% 1/4W	144513
R188	RES MF 2.55K 1% 1/4W	144734
R189	RES MF 2.55K 1% 1/4W	144734
R190	RES MF 100K 1% 1/4W	144528
R191	RES MF 22.1K 1% 1/4W	144564
R192	RES MF 100K 1% 1/4W	144528
R193	RES MF 22.1K 1% 1/4W	144564
R194	RES MF 10 OHM 1% 1/4W	144553
R195	RES MF 10 OHM 1% 1/4W	144553
R196	RES MF 10 OHM 1% 1/4W	144553
R197	RES MF 10 OHM 1% 1/4W	144553
R198	RES MF 4.75K 1% 1/4W	144520
R199	RES MF 4.75K 1% 1/4W	144520
R200	RES MF 4.75K 1% 1/4W	144520
R201	RES MF 4.75K 1% 1/4W	144520
R202	RES MF 10 OHM 1% 1/4W	144553
R203	RES MF 10 OHM 1% 1/4W	144553
R204	RES MF 10 OHM 1% 1/4W	144553
R205	RES MF 10 OHM 1% 1/4W	144553
R206	RES MF 100 OHM 1% 1/4W	144568
R207	RES MF 100 OHM 1% 1/4W	144568
R208	RES MF 4.75K 1% 1/4W	144520
R210	RES MF 100K 1% 1/4W	144528
T1	TRANSFORMER DIGITAL INTERFACE	159351
U1	IC QUAD AND GATE	133372
U2	PROGRAMMED VERSION OF 133495	133706
(U2)	IC SOCKET 28 PIN PLCC	178186
U3	SINGLE 2-INPUT NOR GATE	133500

Ref No.	Description	Part No.
U4	SINGLE 2-INPUT NAND GATE	133501
U5	SINGLE 2-INPUT AND GATE	133552
U6	SINGLE 2-INPUT AND GATE	133552
U7	SINGLE 2-INPUT OR GATE	133516
U8	SINGLE 2-INPUT AND GATE	133552
U9	IC TIMER	133612
U10	IC QUAD AND GATE	133372
U11	IC MONOSTB MULTIVIB X 2	133593
U12	SINGLE 2-INPUT AND GATE	133502
U13	IC 3.3V LOW DROP REGULATOR	133464
U14	IC PROGRAMMABLE LOGIC DEVICE	310370
U15	DSD1792DB	133441
U16	IC SPST QUAD FET SWITCHES NO	133580
U17	IC OP AMP DUAL FET INPUT	133432
U18	IC OP AMP DUAL FET INPUT	133432
U19	IC DUAL OPERATIONAL AMPLIFIER	133578
U20	IC DUAL OPERATIONAL AMPLIFIER	133578
U21	IC DUAL OPERATIONAL AMPLIFIER	133578
U22	IC DUAL OPERATIONAL AMPLIFIER	133578
U23	IC DUAL OPERATIONAL AMPLIFIER	133578
U24	IC DUAL OPERATIONAL AMPLIFIER	133578
U25	CONTROL VOLUME STEREO	133638
U26	IC DUAL OPERATIONAL AMPLIFIER	133578
U27	IC DUAL OPERATIONAL AMPLIFIER	133578
U28	IC DUAL OPERATIONAL AMPLIFIER	133578
U29	IC OPERATIONAL AMP LOW NOISE	133565
U30	IC OPERATIONAL AMP LOW NOISE	133565
U31	COUPLER OPTICAL SCHMITT OUTPUT	131030
Y1	RESONATOR CERAMIC 6.0MHZ W/CAP	180072
Y2	CRYSTAL OSCILLATOR 33.8688MHZ	180083

4 DISPLAY PCB 750773

C1	CAP ELECT 47UF 16V	066380
C2	CAP MONO .1UF 50V 20% Z5U	061346
C3	CAP MONO .1UF 50V 20% Z5U	061346
C4	CAP MONO .1UF 50V 20% Z5U	061346
C5	CAP MONO .1UF 50V 20% Z5U	061346
C6	CAP MONO .1UF 50V 20% Z5U	061346
C7	CAP ELECT 47UF 16V	066380
C8	CAP ELECT 47UF 16V	066380
C9	CAP ELECT 47UF 16V	066380
C10	CAP ELECT 47UF 16V	066380
C11	CAP ELECT 10UF 50V LOW ESR	066437
C12	CAP MONO .1UF 50V 20%	061346
C14	CAP MONO 100PF 100V 10% NPO	061341
C15	CAP MONO .01UF 50V 20%	061345
C16	CAP MONO 100PF 100V 10% NPO	061341
C17	CAP MONO .01UF 50V 20%	061345
C18	CAP MONO 100PF 100V 10% NPO	061341
C19	CAP MONO .01UF 50V 20%	061345
C20	CAP MONO .01UF 50V 20%	061345
C21	CAP MONO .01UF 50V 20%	061345
C22	CAP MONO .01UF 50V 20%	061345
C23	CAP MONO .01UF 50V 20%	061345
C24	CAP MONO .01UF 50V 20%	061345
C25	CAP MONO .1UF 50V 20%	061346
C26	CAP MONO 39PF 5% 200V	061363
C27	CAP ELECT 10UF 16V	066580
C28	CAP MONO 100PF 100V 10% NPO	061341
C29	CAP MONO 100PF 100V 10% NPO	061341
C30	CAP MONO 100PF 100V 10% NPO	061341
C31	CAP MONO .1UF 50V 20%	061346
C32	CAP ELECT 47UF 16V	066380
C33	CAP MONO .1UF 50V 20%	061346

PARTS LIST *con't*

DISPLAY PCB 750773 (cont'd)

Ref No.	Description	Part No.
DS1	LED GREEN 5MM HI-INT	058165
(DS1)	SPACER LED	112108
DS2	LED GREEN 5MM HI-INT	058165
(DS2)	SPACER LED	112108
DS3	FL TUBE 8BT258GINK	310369
DS4	DISPLAY 4 DIGITS DOT MATRIX VFD	058188
DS5	LED RED 5MM ROUND	058187
(DS5)	LED SPACER .220 LENGTH	163001
DS6	LED RED 5MM ROUND	058187
(DS6)	LED SPACER .220 LENGTH	163001
FN1	FILTER EMI	180057
J1	7 PIN SHROUDED HEADER	117910
J2	CONN 13 PIN FFC	117919
J3	CONNECTOR FFC 8 PIN	117915
J4	CONN FFC 18PIN	117908
L1	BEADS FERRITE LEADED	076023
L2	CHOKER 18UH 5%-10%	122394
L3	BEADS FERRITE LEADED	076023
	TAPE FOAM 3/16 THK 1 X 1/2 BLK	094509
	BUMPER DOT 1/2 DIA X 1/2 THK	094510
MT1	SENSOR IR 38KHZ	121046
PCB1	PC BD DISPLAY	129869
Q1	TRANSISTOR NPN SILICON	132317
Q2	TRANSISTOR NPN SILICON	132317
Q3	TRANSISTOR NPN SILICON	132317
R1	RES MF 150 OHM 1% 1/4W	144535
R2	RES MF 100 OHM 1% 1/4W	144568
R3	RES MF 150 OHM 1% 1/4W	144535
R4	RES MF 100 OHM 1% 1/4W	144568
R5	RES MF 1K 1% 1/4W	144513
R6	RES MF 1K 1% 1/4W	144513
R7	RES NETWORK 5X47K BUSSED	144499
R8	RES MF 10 OHM 1% 1/4W	144553
R9	RES MF 10 OHM 1% 1/4W	144553
R10	RES NETWORK 4 X 100 ISO	144676
R11	RES NET 10K X8 RES B	144675
R12	RES MF 47.5K 1% 1/4W	144526
R13	RES MF 2.87K 1% 1/4W	144546
R14	RES MF 3.32K 1% 1/4W	144518
R15	RES MF 4.75K 1% 1/4W	144520
R16	RES MF 10 OHM 1% 1/4W	144553
R17	RES NETWORK 4 X 100 ISO	144676
R18	RES MF 47.5K 1% 1/4W	144526
R19	RES NETWORK 5X47K BUSSED	144499
R20	RES MF 8.25K 1% 1/4W	144549
R21	RES MF 8.25K 1% 1/4W	144549
R22	RES MF 8.25K 1% 1/4W	144549
R23	RES MF 8.25K 1% 1/4W	144549
R24	RES MF 8.25K 1% 1/4W	144549
R25	RES MF 8.25K 1% 1/4W	144549
S1	SWITCH PB TACT	150058
S2	SWITCH PB TACT	150058
S3	SWITCH PB TACT	150058
S4	SWITCH PB TACT	150058
S5	SWITCH PB TACT	150058
S6	SWITCH PB TACT	150058
S7	SWITCH PB TACT	150058
S8	SWITCH PB TACT	150058
S9	SWITCH PB TACT	150058
U1	DECIMAL TO BCD ENCODER	133454

Ref No. Description

Part No.

CONTROL PCB 750295

C2	CAP MONO .1UF 50V 20% Z5U	061346
C3	CAP MONO .1UF 50V 20% Z5U	061346
C4	CAP MONO .1UF 50V 20% Z5U	061346
DS1	LED GRN 5MM HI-INTENSITY	058165
(DS1)	SPACER LED	112108
DS2	LED GRN 5MM HI-INTENSITY	058165
(DS2)	SPACER LED	112108
DS3	LED GRN 5MM HI-INTENSITY	058165
(DS3)	SPACER LED	112108
J1	CONN 8 PIN FFC	117915
PCB1	PC BD CONTROL	129716
R1	RES MF 100 OHM 1% 1/4W	144568
R2	RES MF 100 OHM 1% 1/4W	144568
R4	RES MF 100 OHM 1% 1/4W	144568
S2	SWITCH ROT ENCODER NO DETENT	146256
S1	ENCODER 11MM SELF-RETURN TYPE	146257

POWER PCB 750772

C1	CAP ELECT 470UF 16V	066508
C2	CAP MONO .1UF 50V 20% Z5U	061346
C3	CAP ELECT 22000UF 16V	066579
C4	CAP MPF 0.033UF 100V 10%	064427
C5	CAP ELECT 100UF 25V	066573
C6	CAP ELECT 47UF 35V	066446
C7	CAP MONO .1UF 50V 20% Z5U	061346
C8	CAP ELECT 47UF 35V	066446
C9	CAP ELECT 3300UF 35V	066509
C10	CAP MPF 0.033UF 100V 10%	064427
C11	CAP ELECT 220UF 50V 20%	066254
C12	CAP ELECT 220UF 50V 20%	066254
C13	CAP MPF 0.033UF 100V 10%	064427
C14	CAP MONO .1UF 50V 20% Z5U	061346
C15	CAP ELECT 22000UF 16V	066579
C16	CAP ELECT 3300UF 35V	066509
C17	CAP ELECT 3300UF 35V	066509
C18	CAP ELECT 3300UF 35V	066509
C19	CAP MONO .1UF 50V 20% Z5U	061346
C20	CAP MONO .1UF 50V 20% Z5U	061346
C21	CAP MONO .1UF 50V 20% Z5U	061346
C22	CAP MONO .1UF 50V 20% Z5U	061346
C23	CAP MONO .1UF 50V 20% Z5U	061346
C24	CAP ELECT 470UF 16V	066508
C25	CAP ELECT 470UF 16V	066508
C26	CAP ELECT 470UF 16V	066508
C27	CAP ELECT 220UF 25V	066507
C28	CAP ELECT 220UF 25V	066507
D1	DIODE ZENER 2.4V	070195
D2	DIODE SILICON	070174
D3	DIODE SIL 400 PIV @ 1.5A	070031
D4	DIODE SIL 400 PIV @ 1.5A	070031
D5	DIODE SIL 400 PIV @ 1.5A	070031
D6	DIODE SIL 400 PIV @ 1.5A	070031
D7	DIODE ZENER 33V 5% 1/2W	070182
D8	DIODE SIL 400 PIV @ 1.5A	070031
D9	DIODE SIL 400 PIV @ 1.5A	070031
D10	DIODE SILICON	070174
D11	DIODE SIL 400 PIV @ 1.5A	070031
D12	DIODE SIL 400 PIV @ 1.5A	070031
D13	DIODE SIL 400 PIV @ 1.5A	070031
D14	DIODE SIL 400 PIV @ 1.5A	070031
D15	DIODE SIL 400 PIV @ 1.5A	070031

PARTS LIST *con't*

POWER PCB 750772 (cont'd)

Ref No.	Description	Part No.
D16	DIODE SIL 400 PIV @ 1.5A	070031
D17	SCHOTTKY RECTIFIER 5A 100V	070171
D18	SCHOTTKY RECTIFIER 5A 100V	070171
D19	SCHOTTKY RECTIFIER 5A 100V	070171
D20	SCHOTTKY RECTIFIER 5A 100V	070171
D21	DIODE SIL 400 PIV @ 1.5A	070031
F1	FUSE 2A 250V SLO-BLO 5X20 IEC	089123
(F1)	HOLDER FUSE 5X20MM PCB MOUNT	178159
F2	FUSE 2A 250V SLO-BLO 5X20 IEC	089123
(F2)	HOLDER FUSE 5X20MM PCB MOUNT	178159
F3	FUSE 1A 250V SB 5X20 ULCSA IEC	089132
(F3)	HOLDER FUSE 5X20MM PCB MOUNT	178159
F4	FUSE 1A 250V SB 5X20 ULCSA IEC	089132
(F4)	HOLDER FUSE 5X20MM PCB MOUNT	178159
FN1	FILTER EMI	180057
HS1	HEATSINK TO-218	080020
HS2	HEATSINK TO220	080021
HS3	HEATSINK TO-220	080024
HS4	HEATSINK TO-218	080020
HS5	HEATSINK TO220	080021
HS6	HEATSINK TO220	080021
HS7	HEATSINK TO220	080021
J1	7 PIN SHROUDED HEADER	117910
J2	HEADER 9 CIRCUIT POST NATURAL	117724
J3	10 PIN SHROUDED HEADER 2MM	117973
J4	CONN FFC 18PIN	117908
K1	RELAY POWER TV5 12V	087070
K2	RELAY DPST 12VDC	087059
K3	RELAY DPST 12VDC	087059
	WASHER SHLDR #10 BLK NYLN INS	104101
PCB1	PC BD POWER	129868
Q1	TRANSISTOR NPN SILICON	132317
Q2	TRANSISTOR NPN SILICON	132317
Q3	TRANSISTOR PNP	132263
R1	FUSE RESETTABLE 900mA	144733
R2	RES MF 1.82K 1% 1/4W	144582
R3	RES MF 1.82K 1% 1/4W	144582
R4	RES MF 22.1 OHM 1% 1/4W	144554
R5	RES MF 10K 1% 1/4W	144504
R6	RES MF 10K 1% 1/4W	144504
R7	RES MO 56.2 1% 1W	144695

Ref No.	Description	Part No.
R8	RES MF 10K 1% 1/4W	144504
R9	RES MF 249 OHM 1% 1/4W	144721
R10	RES MF 249 OHM 1% 1/4W	144721
R11	RES MF 10K 1% 1/4W	144504
R12	RES MF 1.21K 1% 1/4W	144566
U1	IC REGULATOR 1.8V	133673
(U1)	SCR MS 4-40 X 3/8 PH PN BLK	400178
(U1)	INSULATOR ISOSTRATE TO 220	084133
U2	IC REGULATOR 5V	133597
(U2)	SCR MS 4-40 X 1/4 PH PN BLK	400121
(U2)	NUT KEP 4-40 CLR	402001
U3	IC REGULATOR 3.3V 1.5A	133674
(U3)	SCR MS 4-40 X 1/4 PH PN BLK	400121
(U3)	NUT KEP 4-40 CLR	402001
U4	IC REGULATOR 5V 1.5A LOW DROP	133610
(U4)	SCR MS 4-40 X 1/4 PH PN BLK	400121
U5	IC 12V REGULATOR LOW DROP	133611
(U5)	SCR MS 4-40 X 1/4 PH PN BLK	400121
(U5)	NUT KEP 4-40 CLR	402001
U6	IC REGULATOR 12V	133590
(U6)	SCR MS 4-40 X 1/4 PH PN BLK	400121
(U6)	NUT KEP 4-40 CLR	402001
U7	IC REGULATOR -12V	133574
(U7)	INSULATOR ISOSTRATE TO 220	084133
(U7)	SCR MS 4-40 X 1/4 PH PN BLK	400121
(U7)	NUT KEP 4-40 CLR	402001

7 PRIMARY PCB 750614

(F1)	HOLDER FUSE 5X20MM PCB MOUNT	178159
J1	CONN PCB MOUNT POWER RED	117719
J2	CONN PCB MOUNT POWER RED	117719
J3	CONN PCB MOUNT POWER RED	117719
J4	CONN PCB MOUNT POWER RED	117719
J5	BLADE FASTON W/FEET	117708
J6	BLADE FASTON W/FEET	117708
	PC BD PRIMARY	129803

8 HEADPHONE PCB 750296

C1	CAP MONO .1UF 50V 20% Z5U	061346
J1	HEADPHONE JACK 1/4	117881
J2	CONN 4 PIN	117215
	PC BD HEADPHONE	129717

REPACKING INSTRUCTIONS

In the event it is necessary to repack the equipment for shipment, the equipment must be packed exactly as shown below. It is very important that the four plastic feet are attached to the bottom of the equipment. This will ensure the proper equipment location on the bottom pad. Failure to do this will result in shipping damage.

Use the original shipping carton and interior parts only if they are all in good serviceable condition. If a shipping carton or any of the interior part(s) are needed, please call or write Customer Service Department of McIntosh Laboratory. Refer to page 4. Please see the Part List for the correct part numbers.

Quantity	Part Number	Description
1	033838	Shipping carton only
4	033837	End cap
1	033836	Inside carton only
1	033725	Top pad
1	034301	Bottom pad
4	017937	Plastic foot
4	400159	#10-32 x 3/4" screw
4	404080	#10-7/16" Flat washer

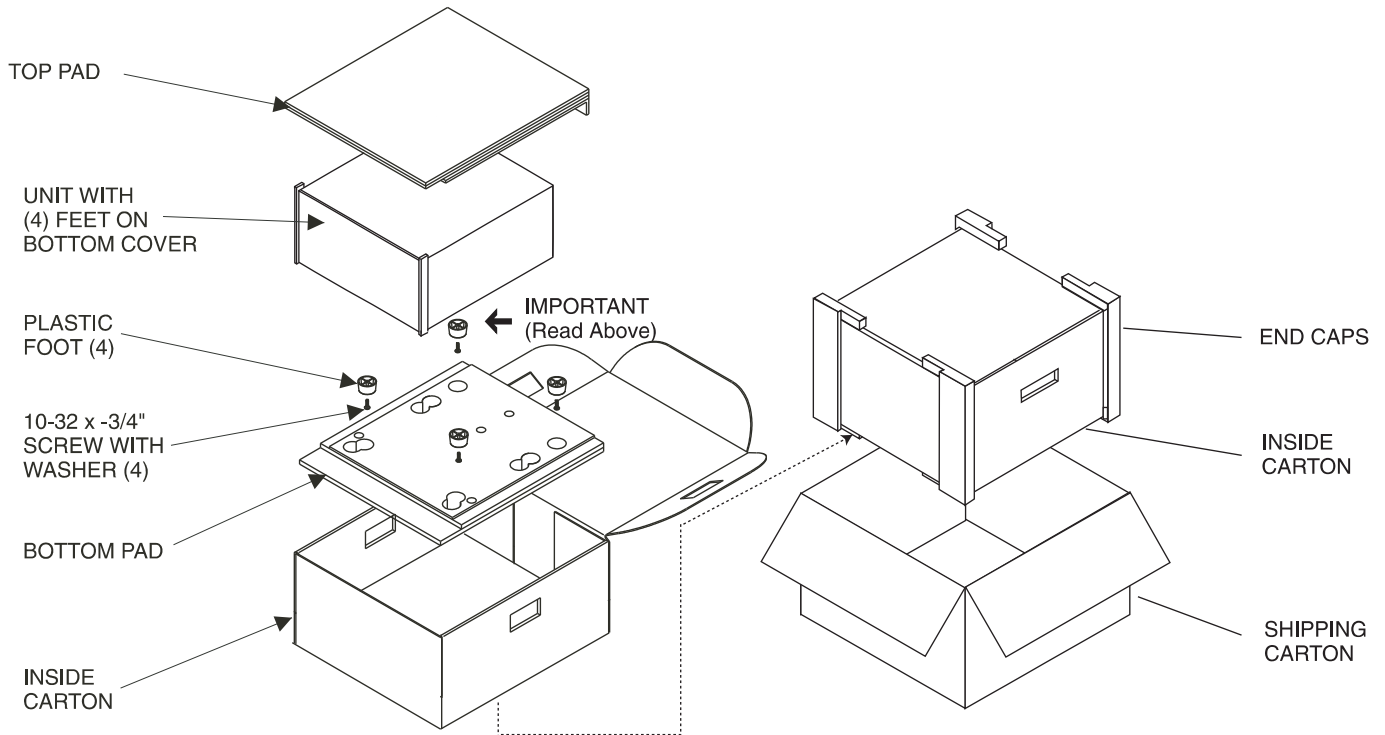

MCD301

SACD / CD PLAYER

SERVICE MANUAL

SERIAL NO. YM1001 And Above



The continuous improvement of its products is the policy of McIntosh Laboratory Incorporated, who reserve the right to improve design without notice. Because of the constant upgrading of McIntosh products' circuitry and components, the Company cannot insure, and does not warrant, the accuracy of the within schematic material, which is intended for information only.