

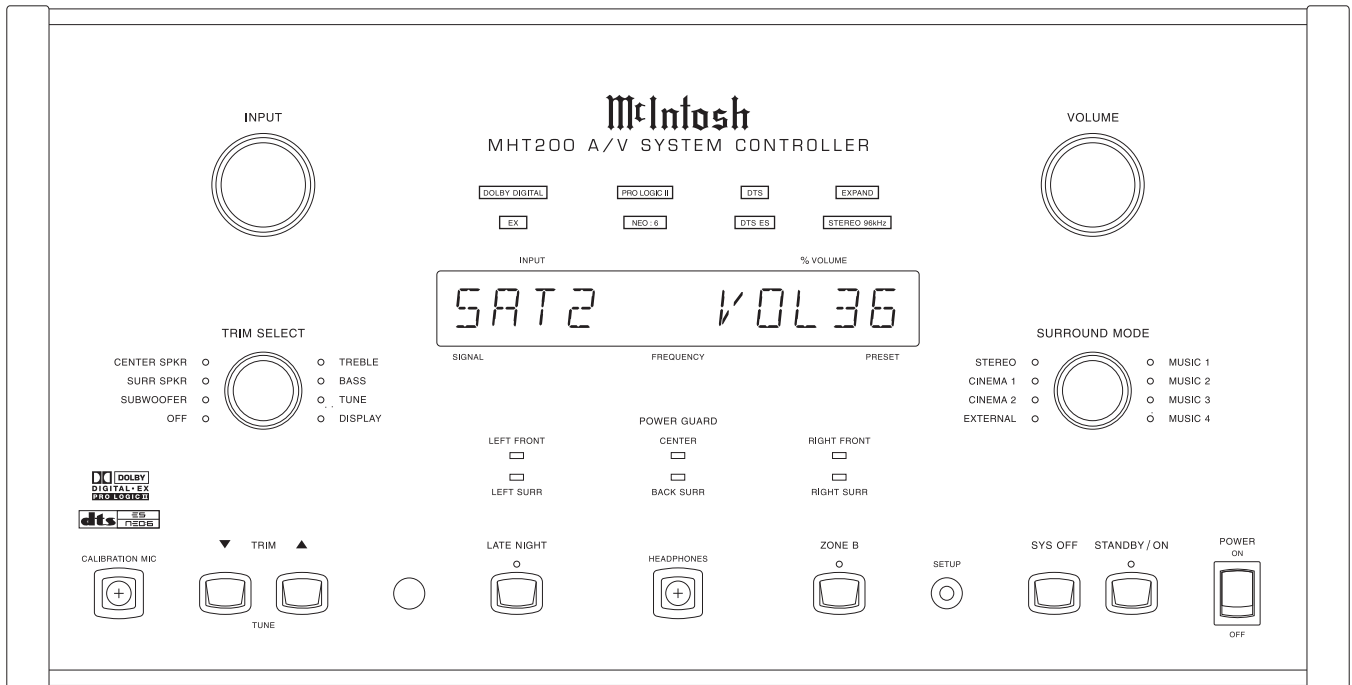

# MHT200

## A/V SYSTEM CONTROLLER



### CONTENTS

Performance Specifications .....	2 - 3	Digital Schematic and PCB .....	37 - 40
Notes .....	3	S-Video Schematic and PCB .....	41 - 52
Rear Panel .....	4	Composite Video Schematic and PCB .....	53 - 58
Section Location .....	4	Main Audio Schematic and PCB .....	59 - 74
Block Diagram .....	5 - 7	Multi Channel Schematic and PCB .....	75 - 86
Interconnection Diagram .....	8 - 10	Amplifier Schematic and PCB .....	89 - 104
Display Schematic and PCB .....	11 - 18	Tuner AM/FM Alignment Procedure .....	105 - 106
Keyboard Schematic and PCB .....	13, 17 - 18	Tuner/RAA1 Schematic and PCB .....	107 - 110
Bottom Schematic and PCB .....	19 - 24	DSP Module PCB .....	111
Power Supply Schematic and PCB .....	25 - 28	Backup Power Supply .....	112
Data2 Schematic and PCB .....	29 - 32	Exploded Views and Parts Lists .....	113 - 114
Data1 Schematic and PCB .....	33 - 36	Repacking Instruction .....	115

# SERVICE MANUAL

# PERFORMANCE SPECIFICATIONS

## Preamplifier and Processor Specifications

### Frequency Response

Stereo:

Left and Right Loudspeakers: +0-0.5dB from 20Hz-20,000Hz

Music 1-4:

Left, Center, Right Loudspeakers: +0-0.5dB from 20Hz-20,000Hz

Large Surround Loudspeakers: +0-0.5dB from 20Hz-20,000Hz

Pro-Logic:

Left, Center, Right, Large Loudspeakers: +/-0.5dB from 20Hz-20,000Hz

Large Surround Loudspeakers: +1-3dB from 20Hz-6.3kHz  
Subwoofer<sup>1</sup>: 20Hz-140Hz

Dolby Digital, DTS and External Input:

Left, Center, Right Large Loudspeakers: +/-0.5dB from 20Hz-20,000Hz

Large Surround Loudspeakers: +/-0.5dB from 20Hz-20,000Hz

Subwoofer<sup>1</sup>: 20Hz-140Hz

### Rated Output

2V for all channels

### Input Impedance

22k ohms

### Output Impedance

Less than 560 ohms for all channels

### Maximum Output Voltage

8V

### Total Harmonic Distortion

0.05% for all channels

### Sensitivity

Analog Input: 100mV IHF

Dolby Level: 200mV Input

External Input: 200mV for 2.0V Output

### Signal To Noise Ratio

Greater than 90dB A-weighted

### Maximum Input Signal

Analog Input: 6Vrms

### Tone Controls

+/-12dB from the flat setting

<sup>1</sup> If any of the channels have the Loudspeaker Setting of Small, the subwoofer has a electronic low pass filter with a corner frequency of 80Hz and a 24dB per Octave roll-off in all modes except external. The Frequency Response of the Subwoofer Channel is also determined by the Crossover Setting.

## Power Amplifier Specifications

### Power Output

Minimum sine wave continuous average power output per channel, all channels operating is: 100 watts into 4 ohm load, 70 watts into a 8 ohm load

### Rated Power Band

20Hz to 20,000Hz

### Total Harmonic Distortion

Maximum Total Harmonic Distortion at any power level from 250 milliwatts to rated power output is: 0.05% for 4 or 8 ohm load

### Dynamic Headroom

1.8dB

### Frequency Response

+0, -0.25dB from 20Hz to 20,000Hz

+0, -3dB from 10Hz to 1000,000Hz

### Sensitivity

1.0 Volt

### A-Weighted Signal To Noise Ratio

92dB (112dB below rated output)

### Intermodulation Distortion

Maximum Intermodulation Distortion if instantaneous peak output per channel does not exceed twice the rated output, for any combination of frequencies from 20Hz to 20,000Hz, with all channels operating is: 0.05% for 4 or 8 ohm loads

### Input Impedance

20,000 ohms

### Wide Band Damping Factor

100 at 4 ohms

200 at 8 ohms

## General Specifications

### Power Requirements

100 Volts, 50/60Hz at 8.4 Amps

110 Volts, 50/60Hz at 7.7 Amps

120 Volts, 50/60Hz at 7.0 Amps

220 Volts, 50/60Hz at 3.5 Amps

230 Volts, 50/60Hz at 3.5 Amps

240 Volts, 50/60Hz at 3.5 Amps

*Note: Refer to rear panel of the MHT200 for the correct voltage.*

### Dimensions

Front Panel: 17-3/4 inches (45.09cm) wide, 9-7/16 inches (23.97cm) high. Depth behind front mounting panel is 19 inches (48.26cm) including clearance for connectors. Panel clearance required in front of mounting panel is 1-1/8 inches (2.9cm).

### Weight

73 pounds (33.1kg) net, 87 pounds (39.5kg) shipping

# PERFORMANCE SPECIFICATIONS *con't*

## FM Tuner

### Useable Sensitivity

14dBm which is 1.4uV across 75 ohms

### 50dB Quieting Sensitivity

Mono: 19dBm which is 2.4uV across 75 ohms

Stereo: 35dBm which is 15uV across 75 ohms

### Signal To Noise Ratio

Mono: 75dB

Stereo: 70dB

### Frequency Response

Mono: +0, -1dB from 20Hz to 15,000Hz

Stereo: +0, -1dB from 20Hz to 15,000Hz

### Harmonic Distortion

Mono: 0.3% at 100Hz, 0.3% at 1,000Hz, 0.3% at 10,000Hz

Stereo: 0.45% at 100Hz, 0.45% at 1,000Hz, 0.65% at 10,000Hz

### Intermodulation Distortion

Mono: 0.25%

Stereo: 0.45%

### Capture Ratio

1.2dB

### Alternate Channel Selectivity

75dB

### Spurious Response

100dB

### Image Response

75dB

## RF Intermodulation

65dB

## Stereo Separation

45dB at 100Hz

45dB at 1,000Hz

35dB at 10,000Hz

## SCA Rejection

65dB

## AM Tuner

### Sensitivity

20uV External Antenna Input

### Signal To Noise Ratio

48dB at 30% modulation

58dB at 100% modulation

### Harmonic Distortion

0.5% maximum at 50% modulation

### Frequency Response

50Hz to 6kHz NRSC

### Adjacent Channel Selectivity

45dB minimum IHF

### Image Rejection

65dB minimum from 540Hz to 1,600kHz

### IF Rejection

80dB minimum

# NOTES

1. The heavy lines on the schematic denote the primary signal path.
2. Unless otherwise noted, all voltages indicated on the schematics are measured under the following conditions:
  - a. AC input at 120 volts, 50/60Hz.
  - b. All voltages are +/-10% with respect to ground. A high impedance (10 megaohm) voltmeter must be used.
4. On PC board drawings, Square pad indicates:
  - a. Polarized Capacitors - Positive
  - b. Diodes - Cathode
  - c. Others - Pin 1
5. **WARNING**  
Parts marked with the symbol  have critical characteristics. Use only replacement parts recommended by the manufacturer.

# REAR PANEL

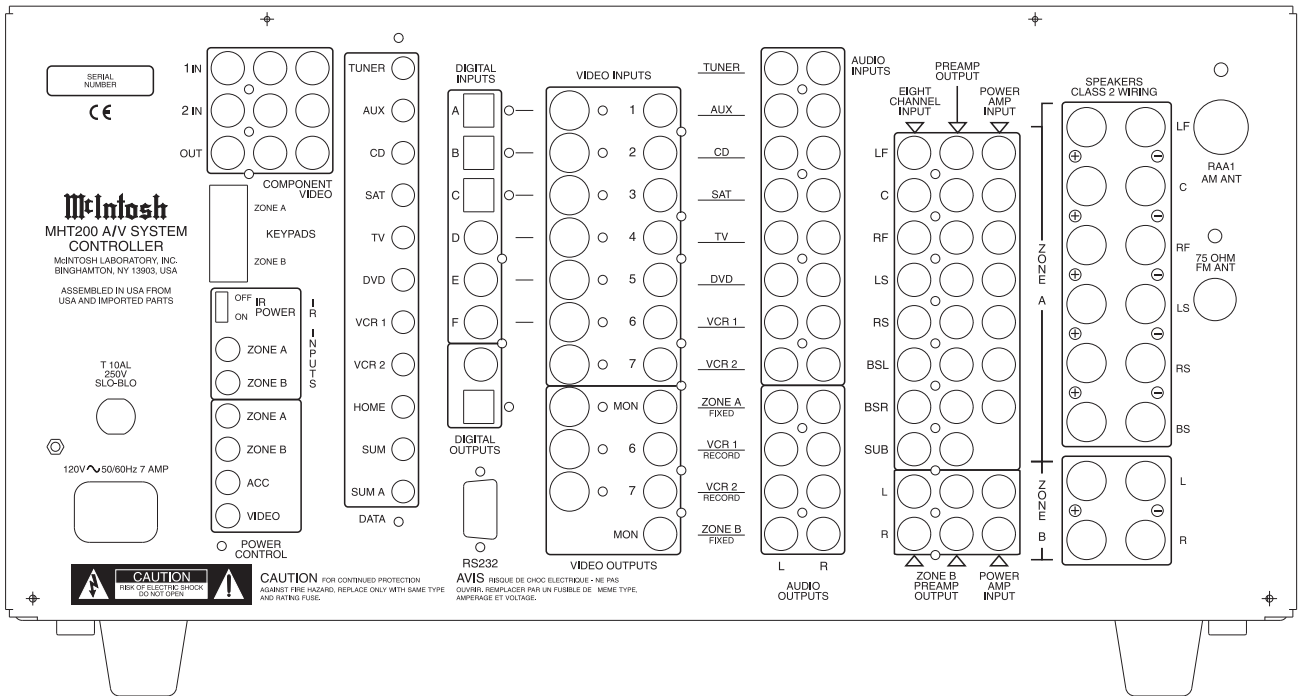

# SECTION LOCATIONS

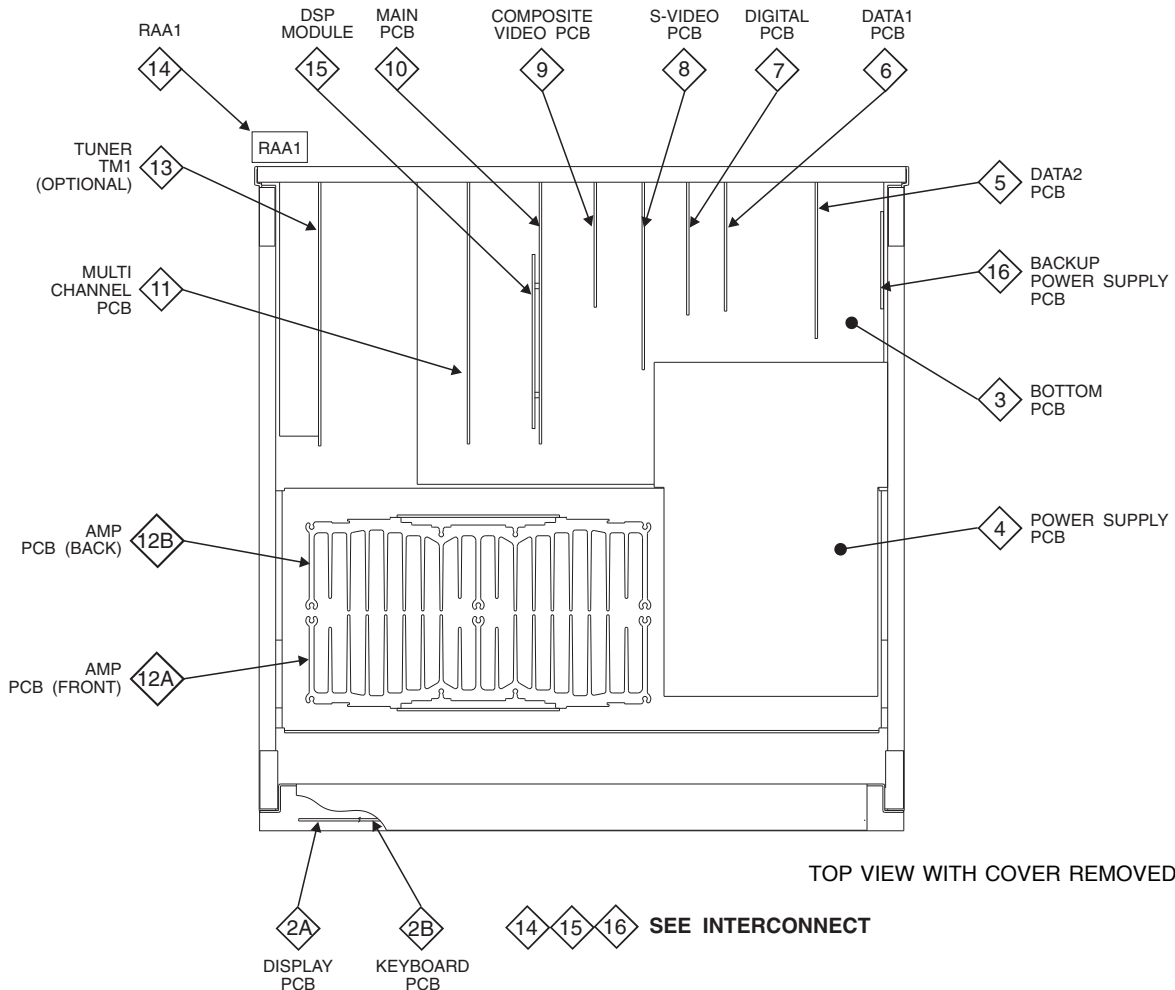

# BLOCK DIAGRAM

MHT200

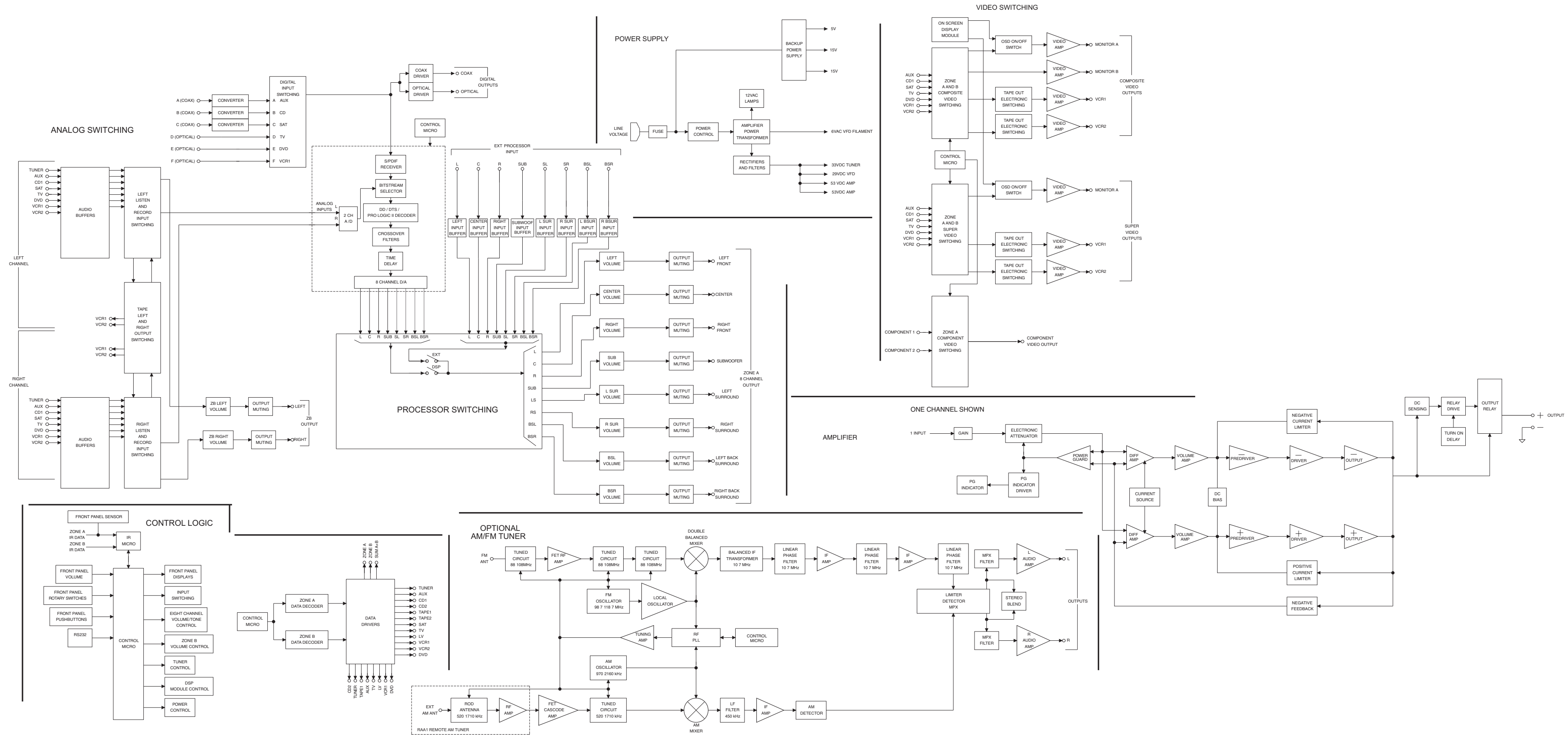

# 1 INTERCONNECT

**!** WARNING Parts located in the shaded area have critical characteristics. Use only replacement parts recommended by the manufacturer.

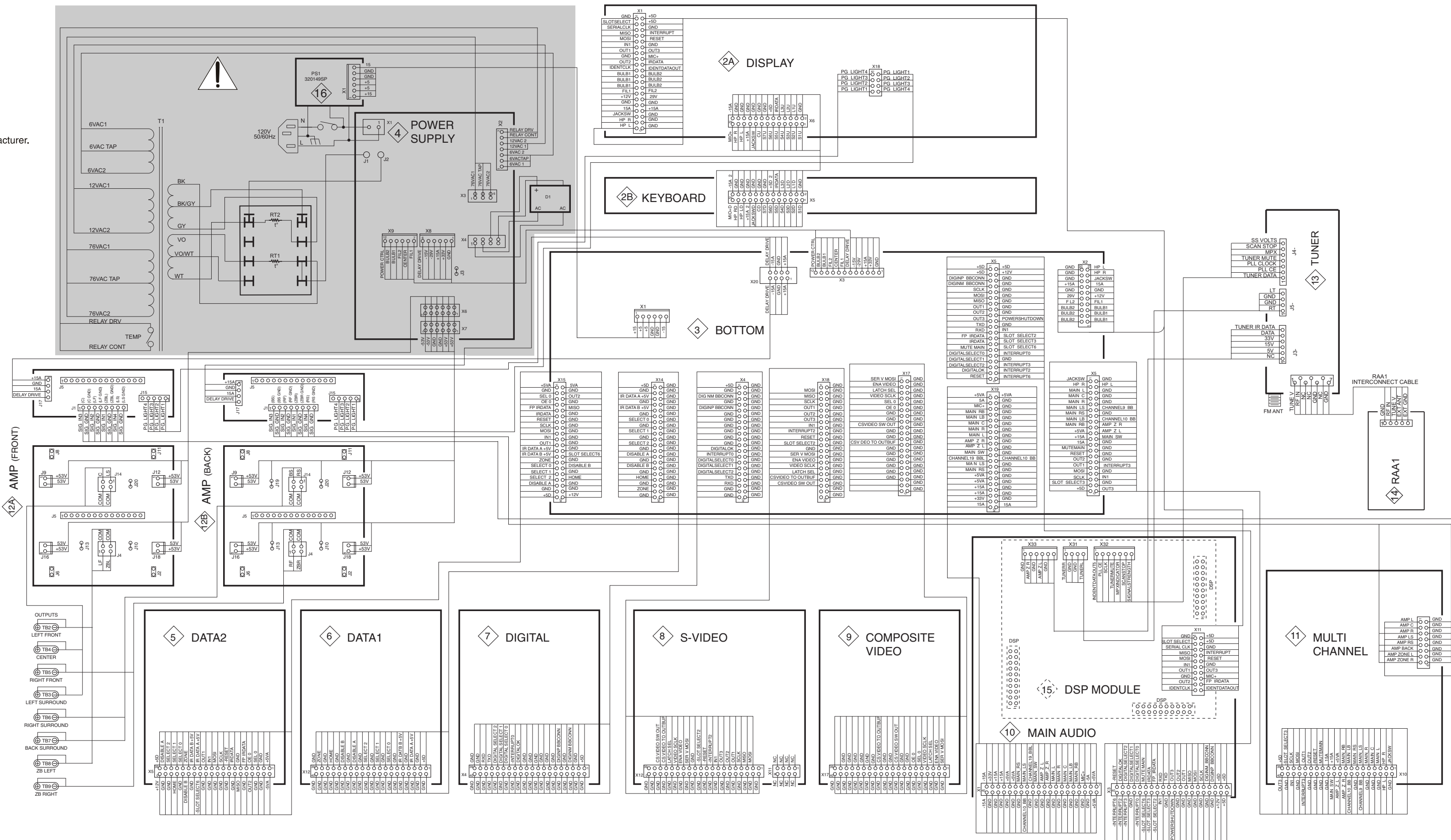

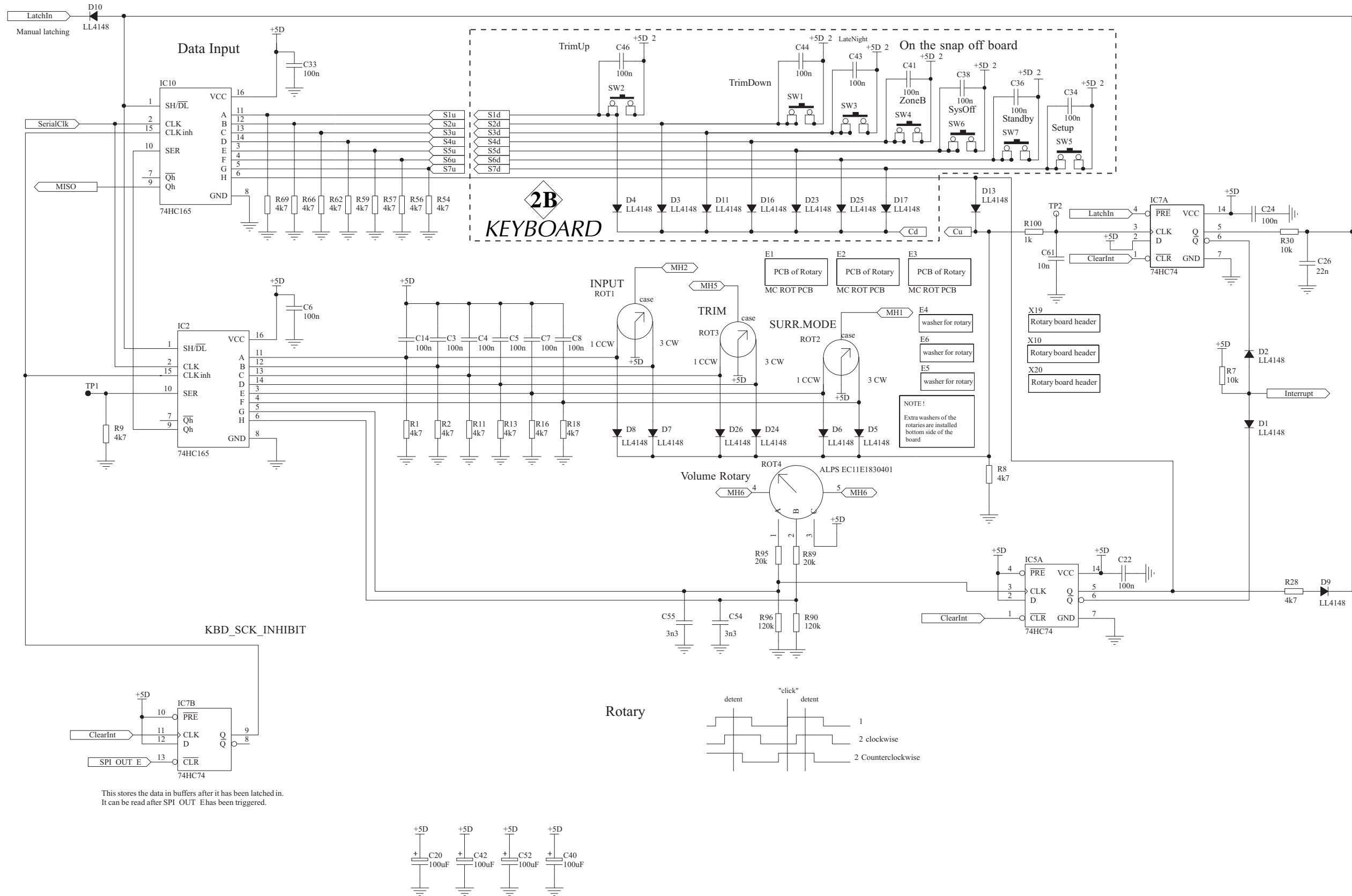

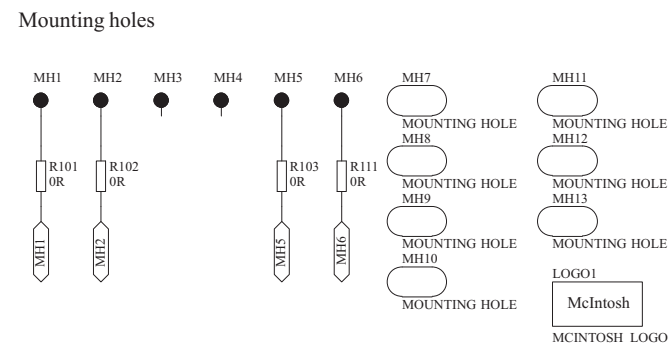
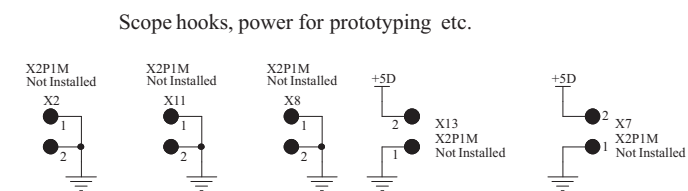
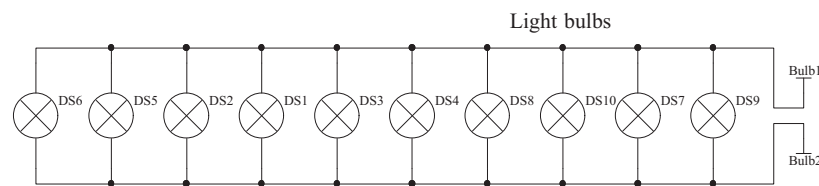
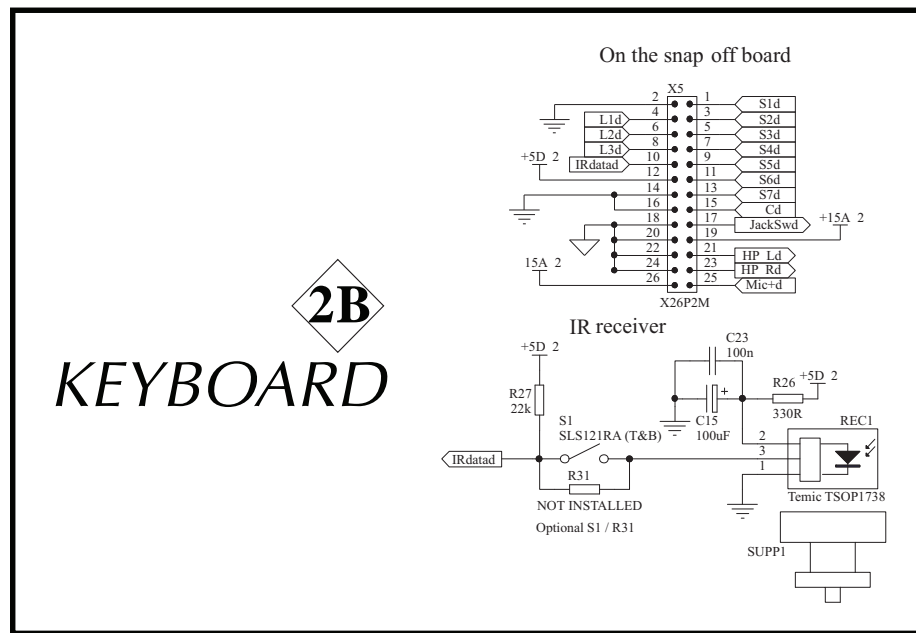
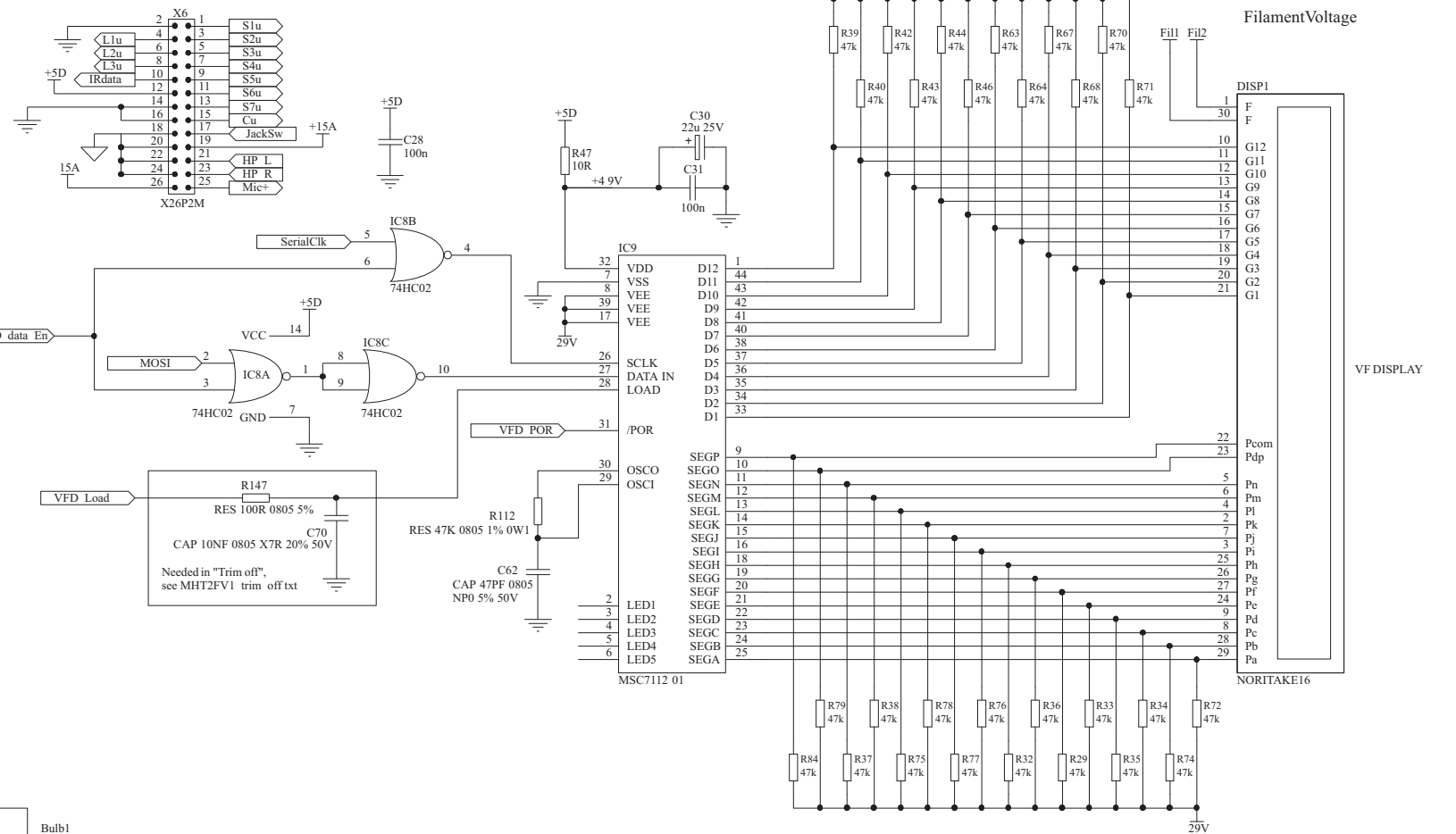
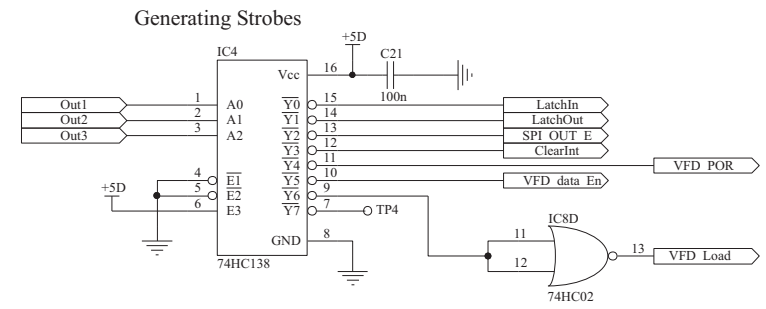
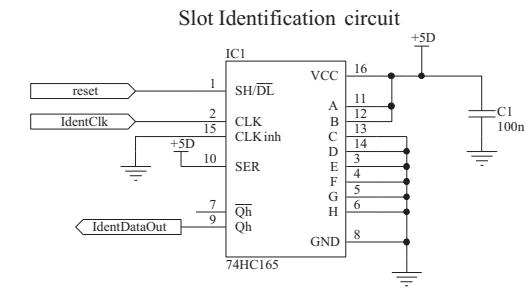
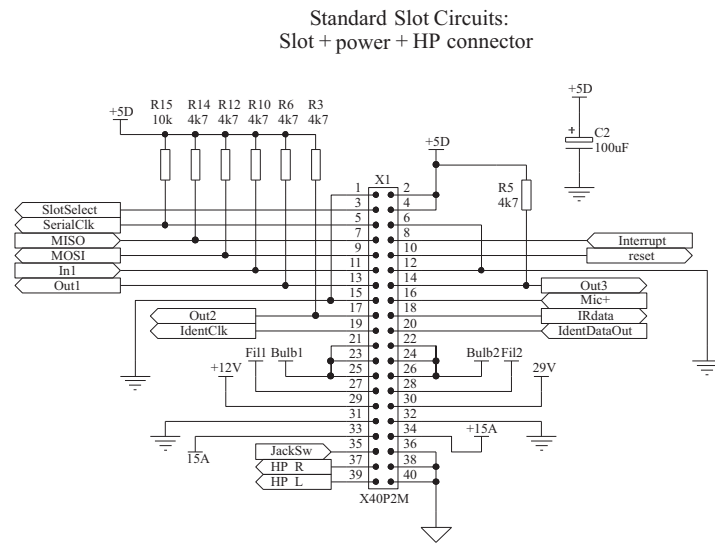



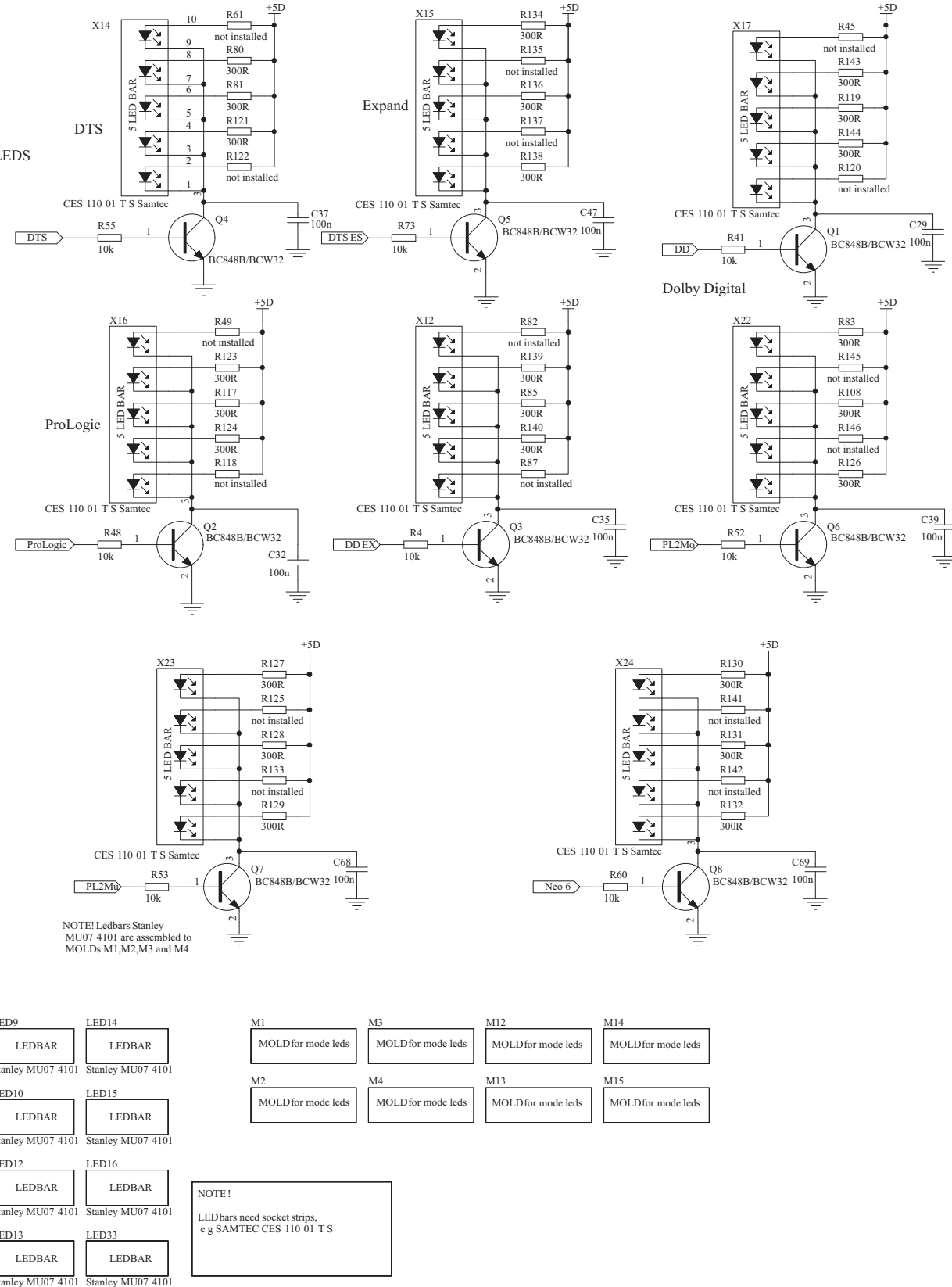
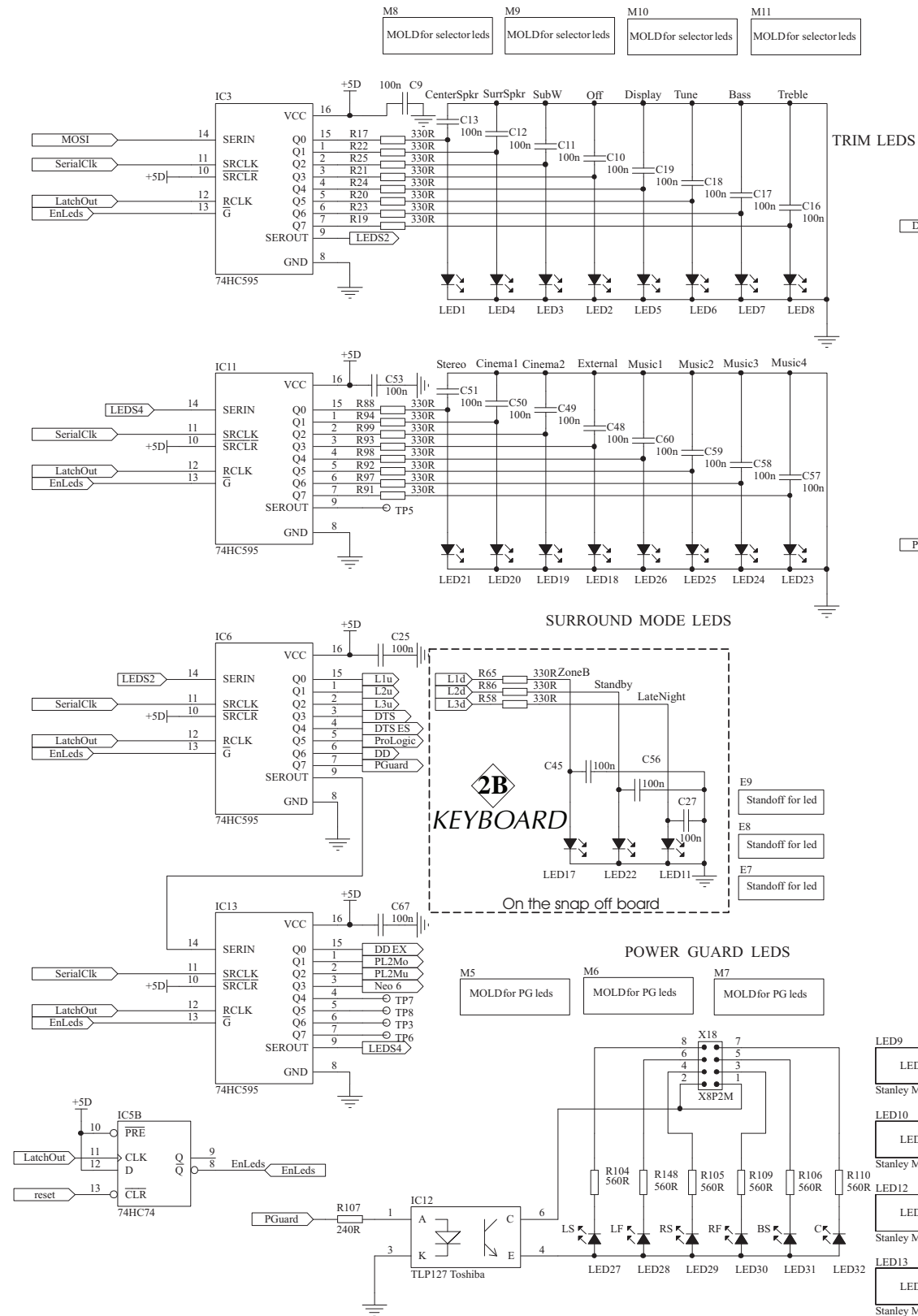

**2A** *DISPLAY 320167 SH 4 OF 4 AND PCB*

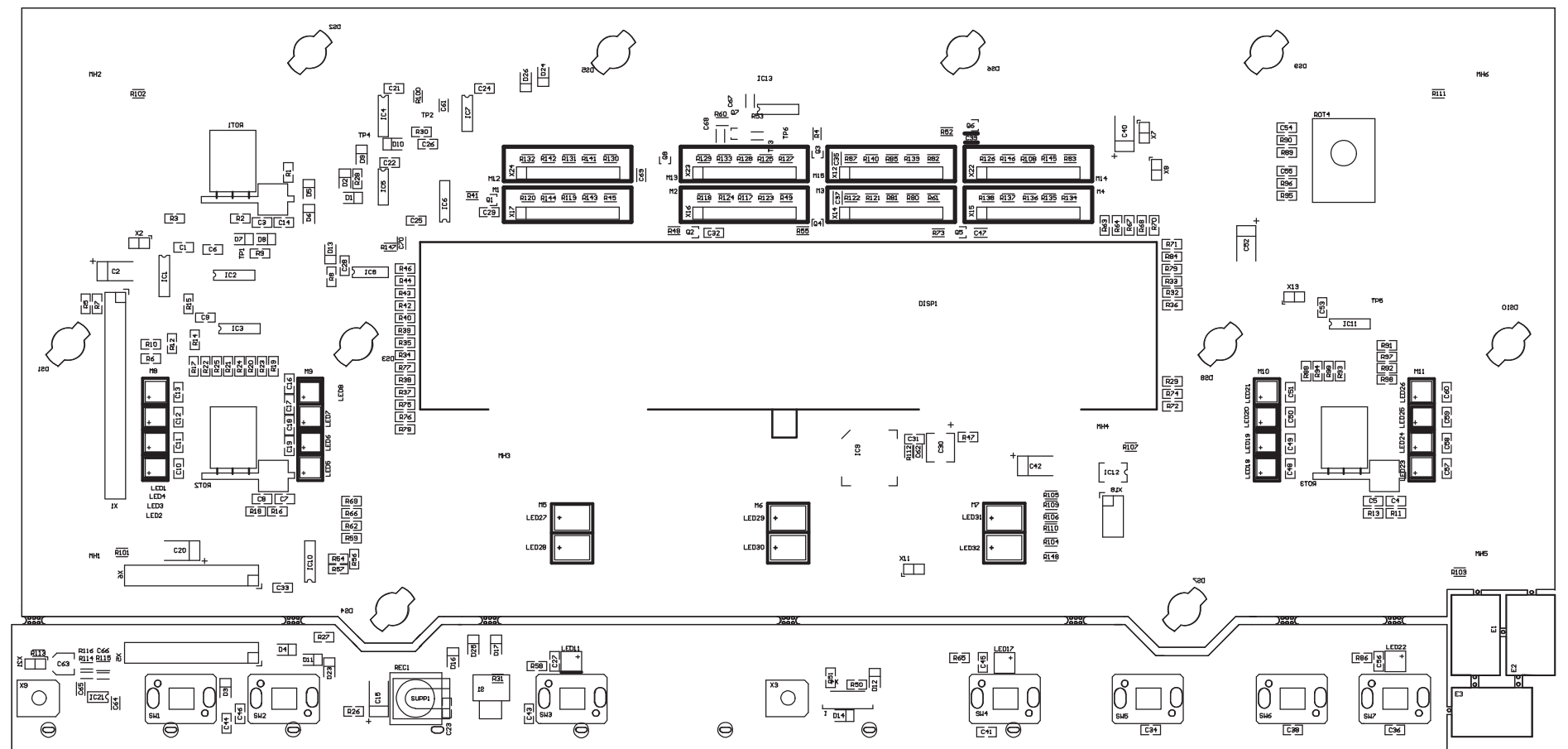
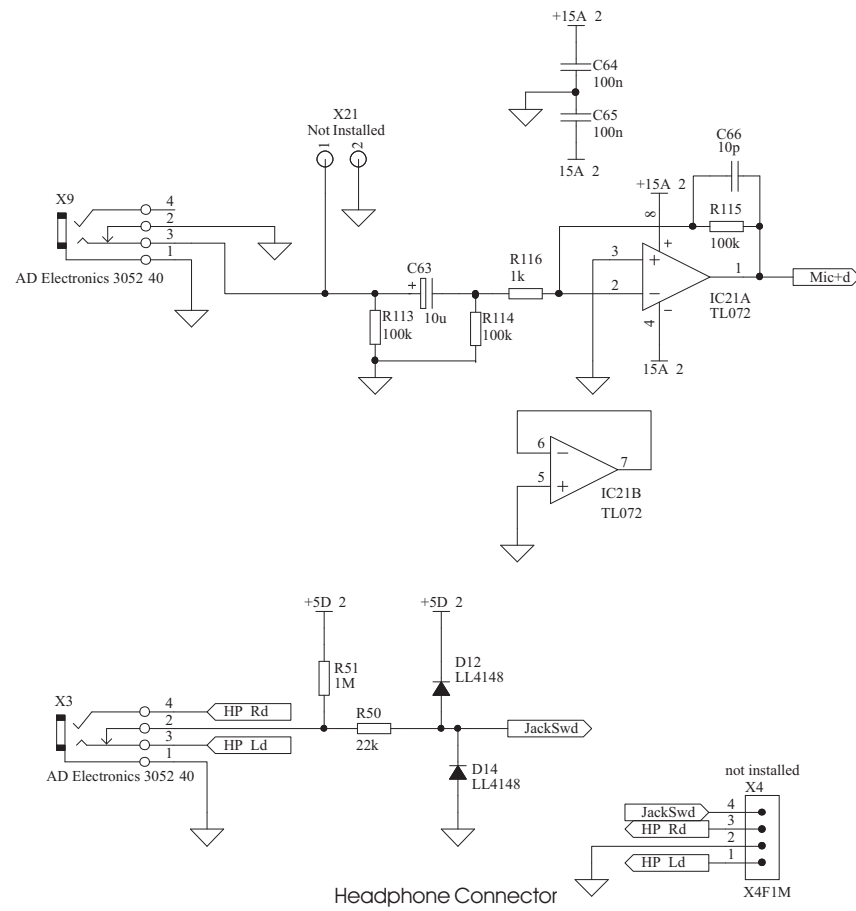

**2B** *KEYBOARD 320167*

**!** WARNING Parts located in the shaded area have critical characteristics. Use only replacement parts recommended by the manufacturer.

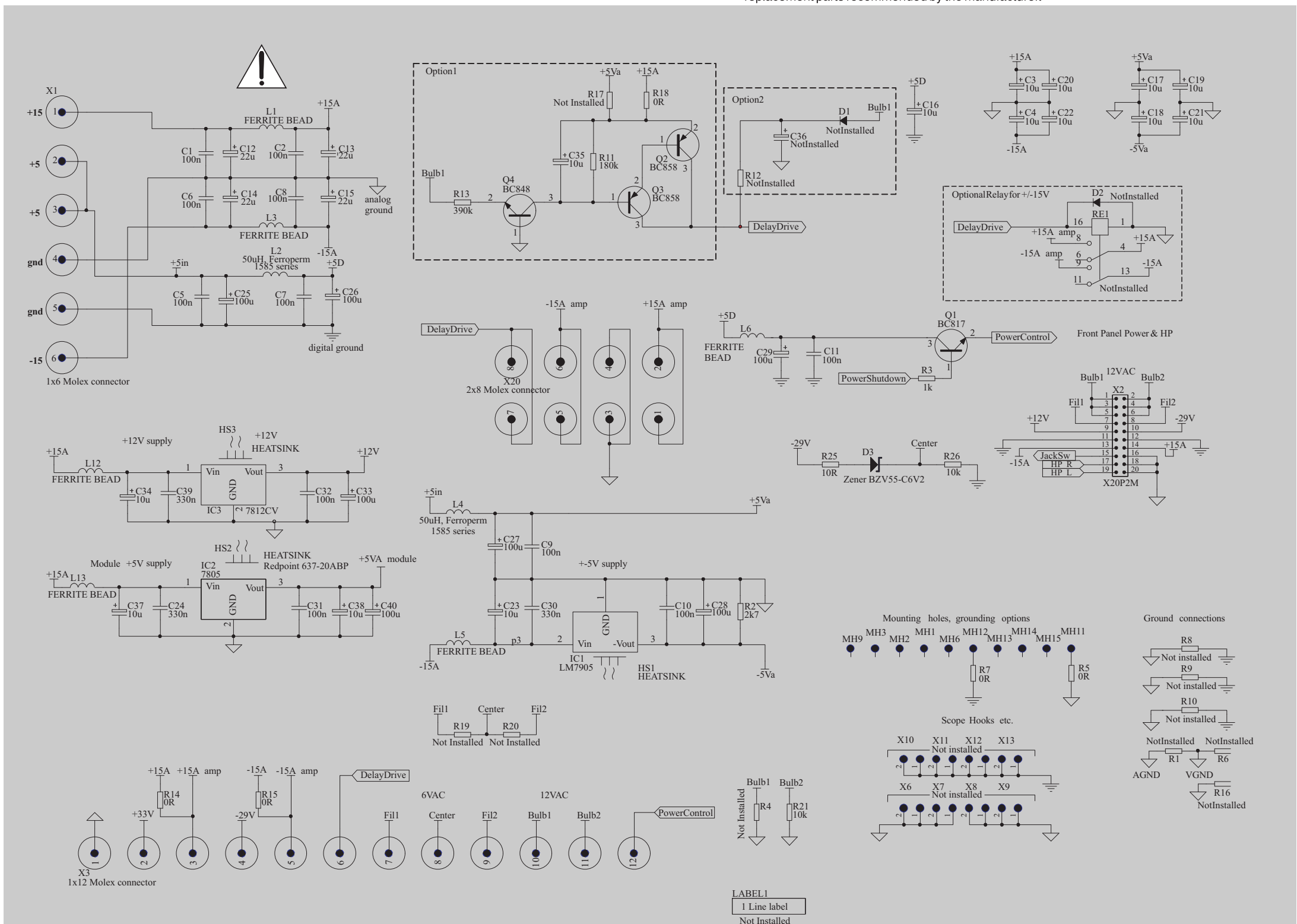

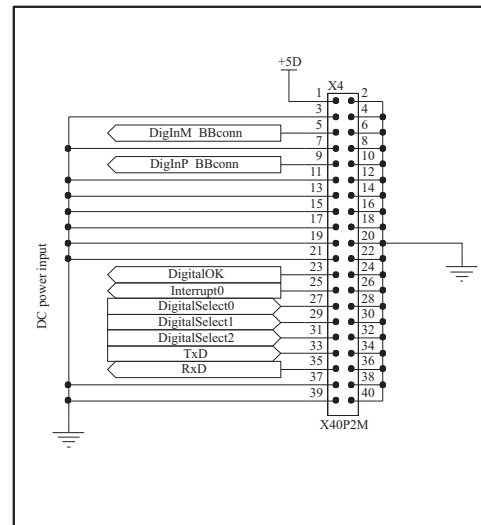

Digital Board

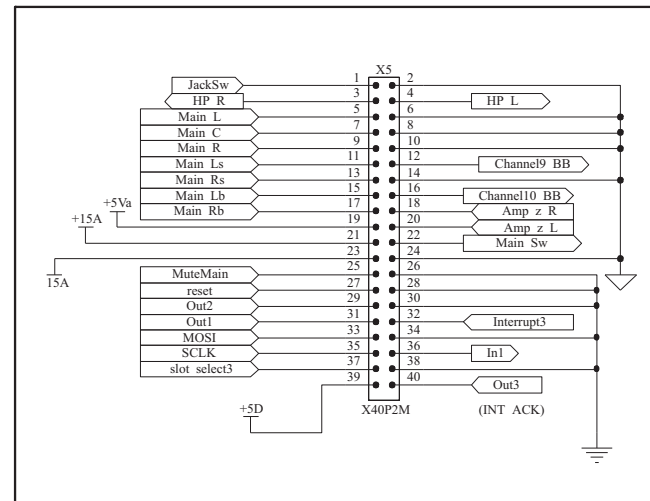

Multichannel Board

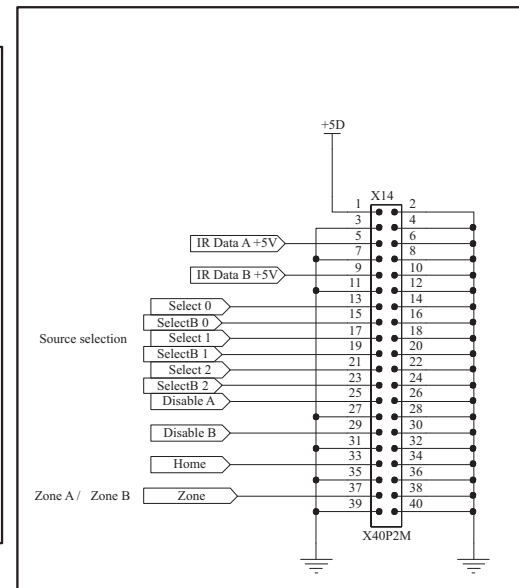

DataBoard 1

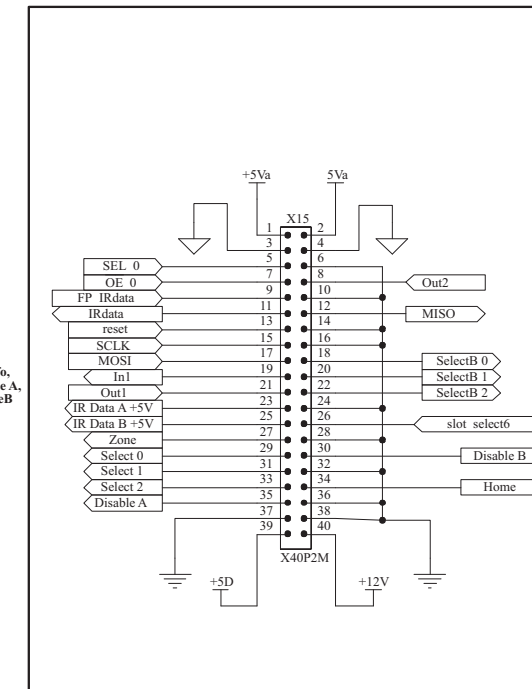

Databoard2

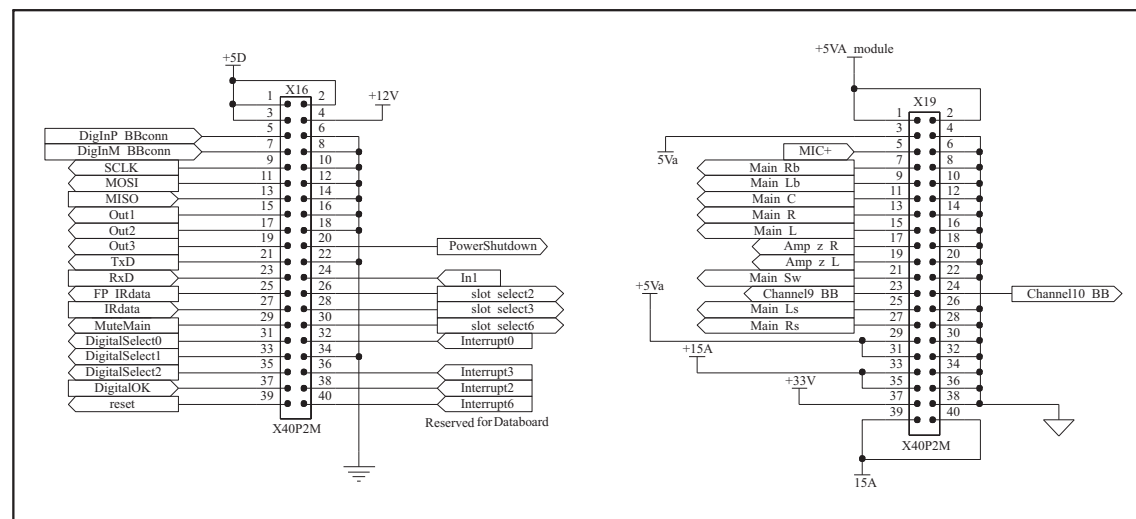

Main Audio Board

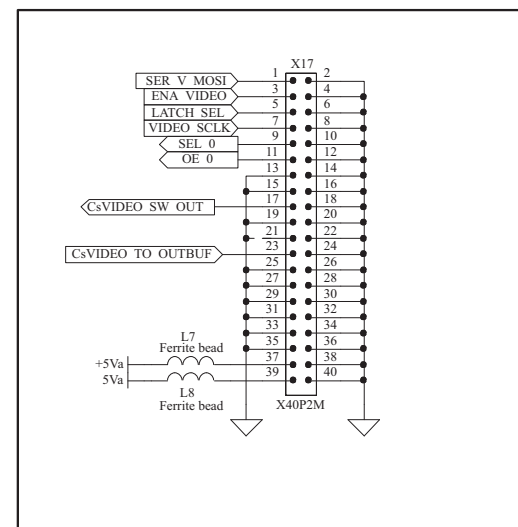

Cs VideoBoard

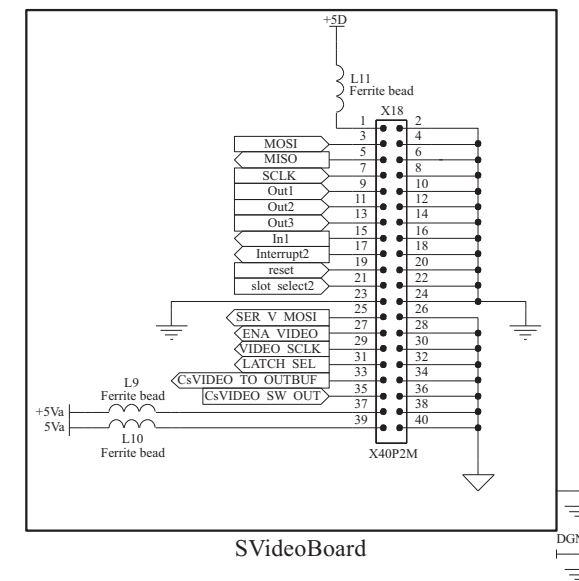

SVideoBoard

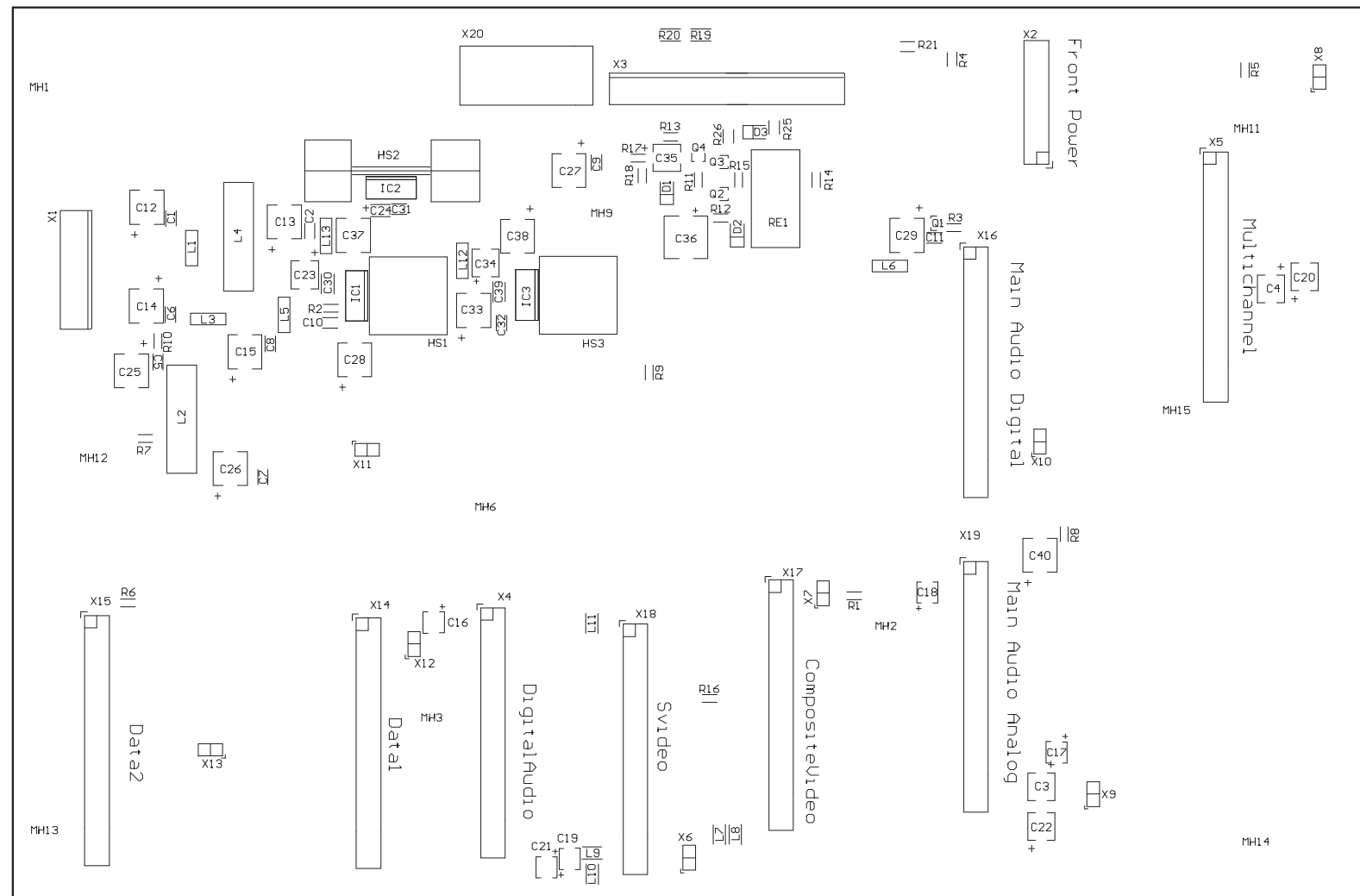

# 4 POWER SUPPLY 320131

**!** WARNING Parts located in the shaded area have critical characteristics. Use only replacement parts recommended by the manufacturer.

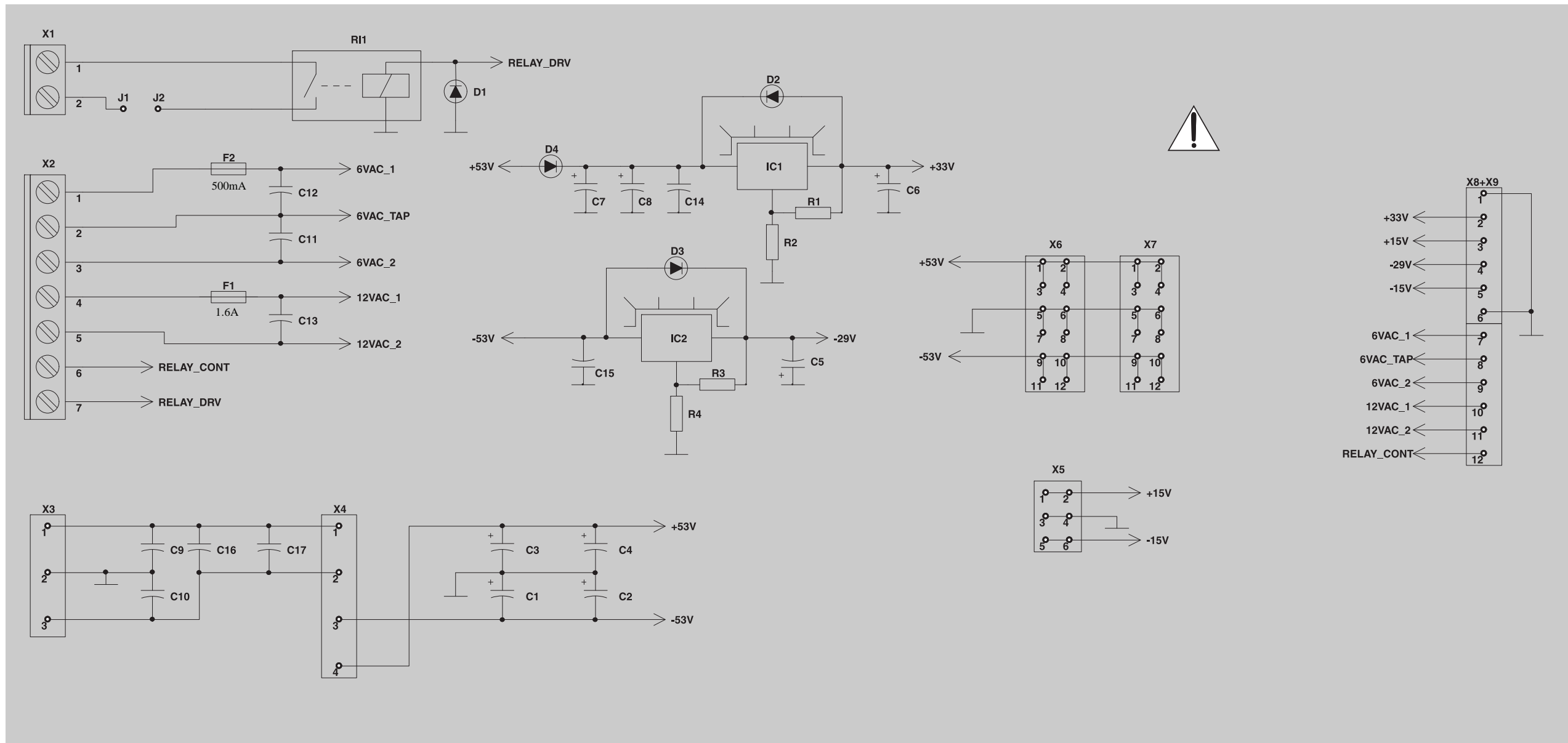

F1 = T1.6AL 250V  
F2 = T500mAL 250V

**4** POWER SUPPLY 320131

**!** WARNING Parts located in the shaded area have critical characteristics. Use only replacement parts recommended by the manufacturer.

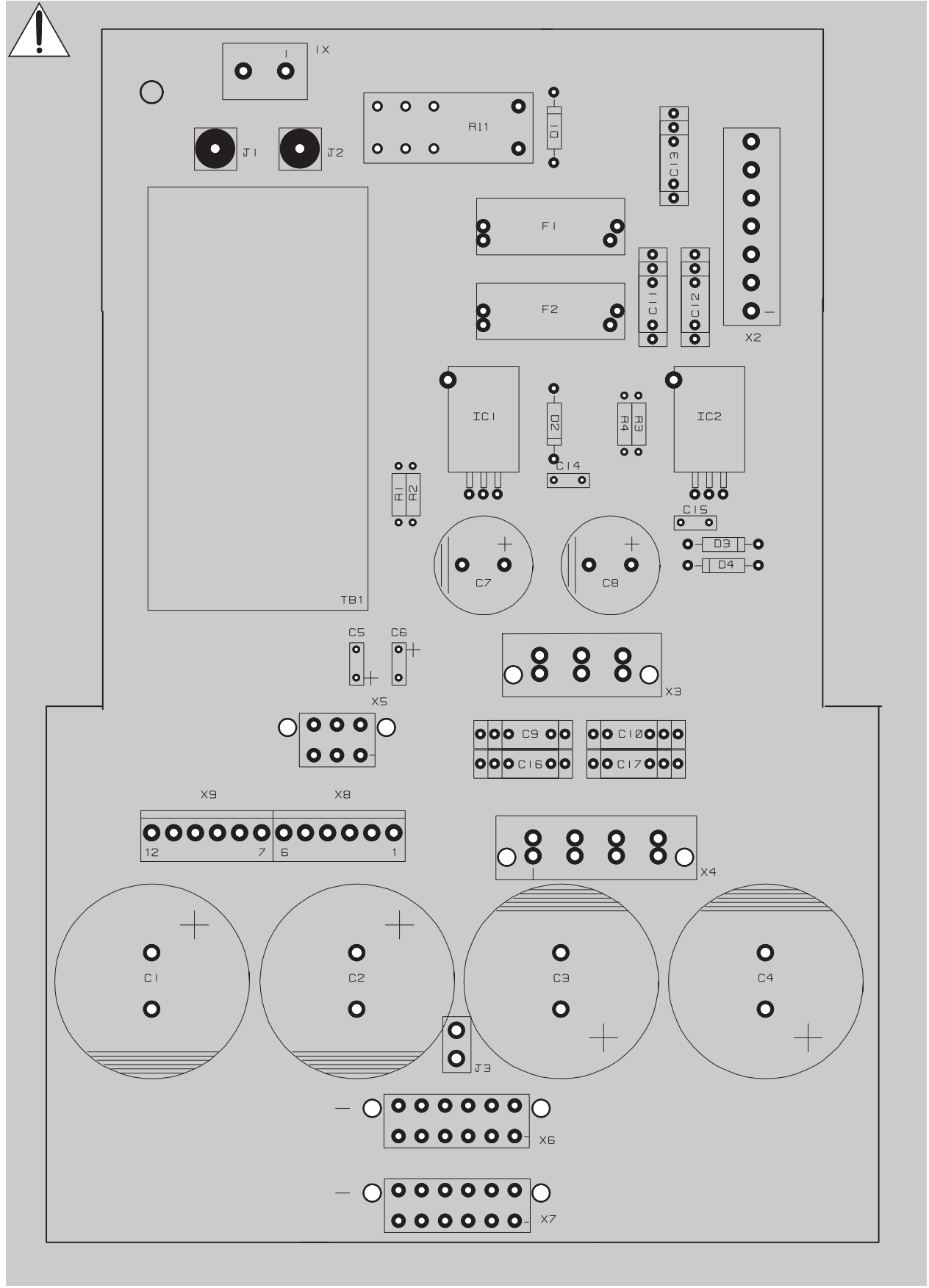

# 5 DATA2 320123

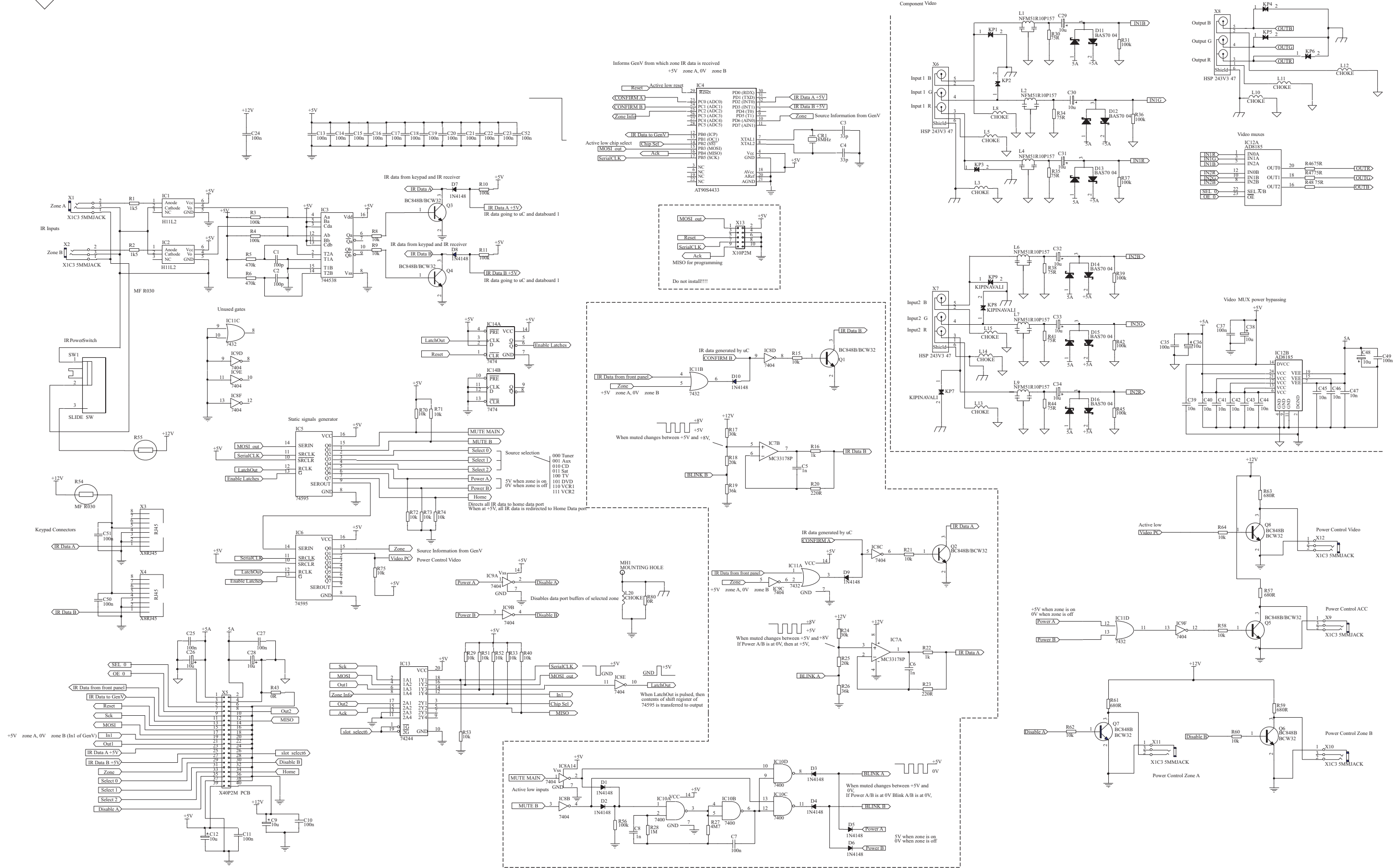



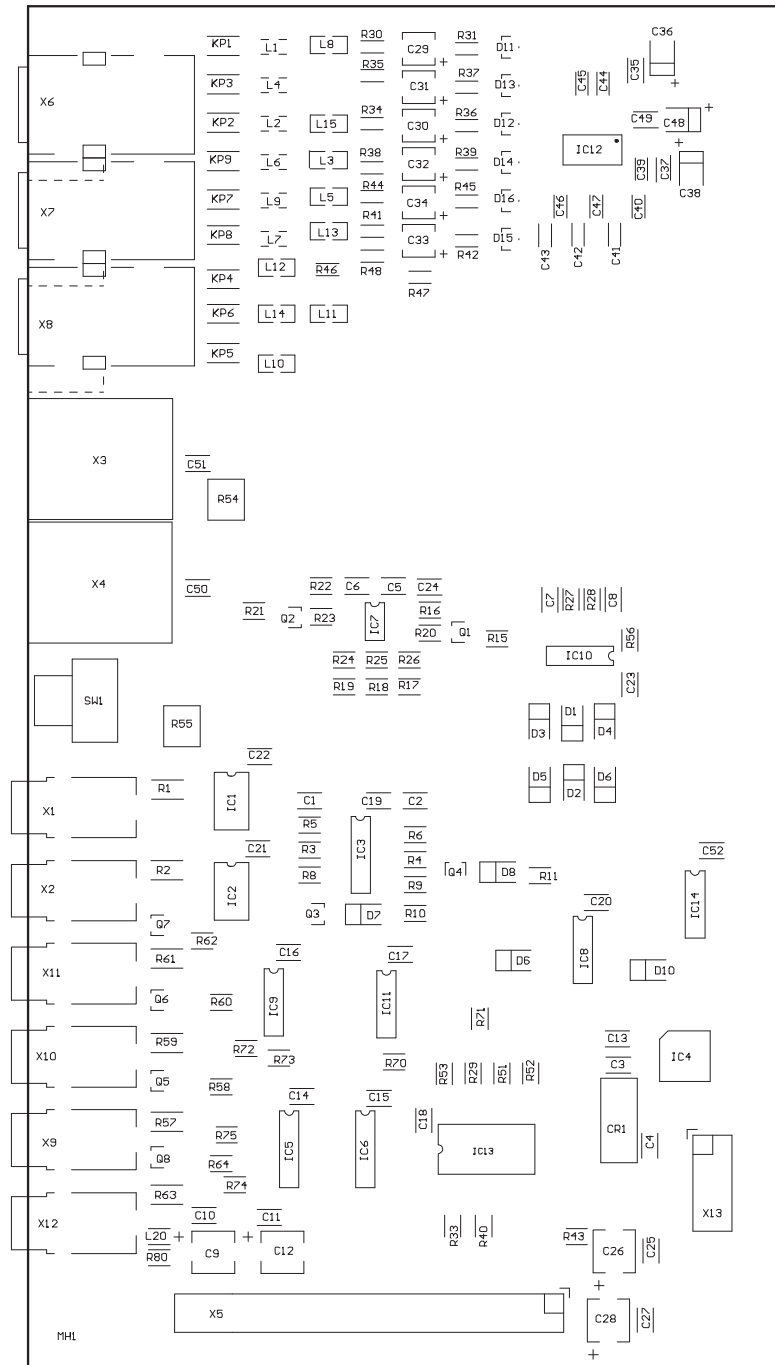

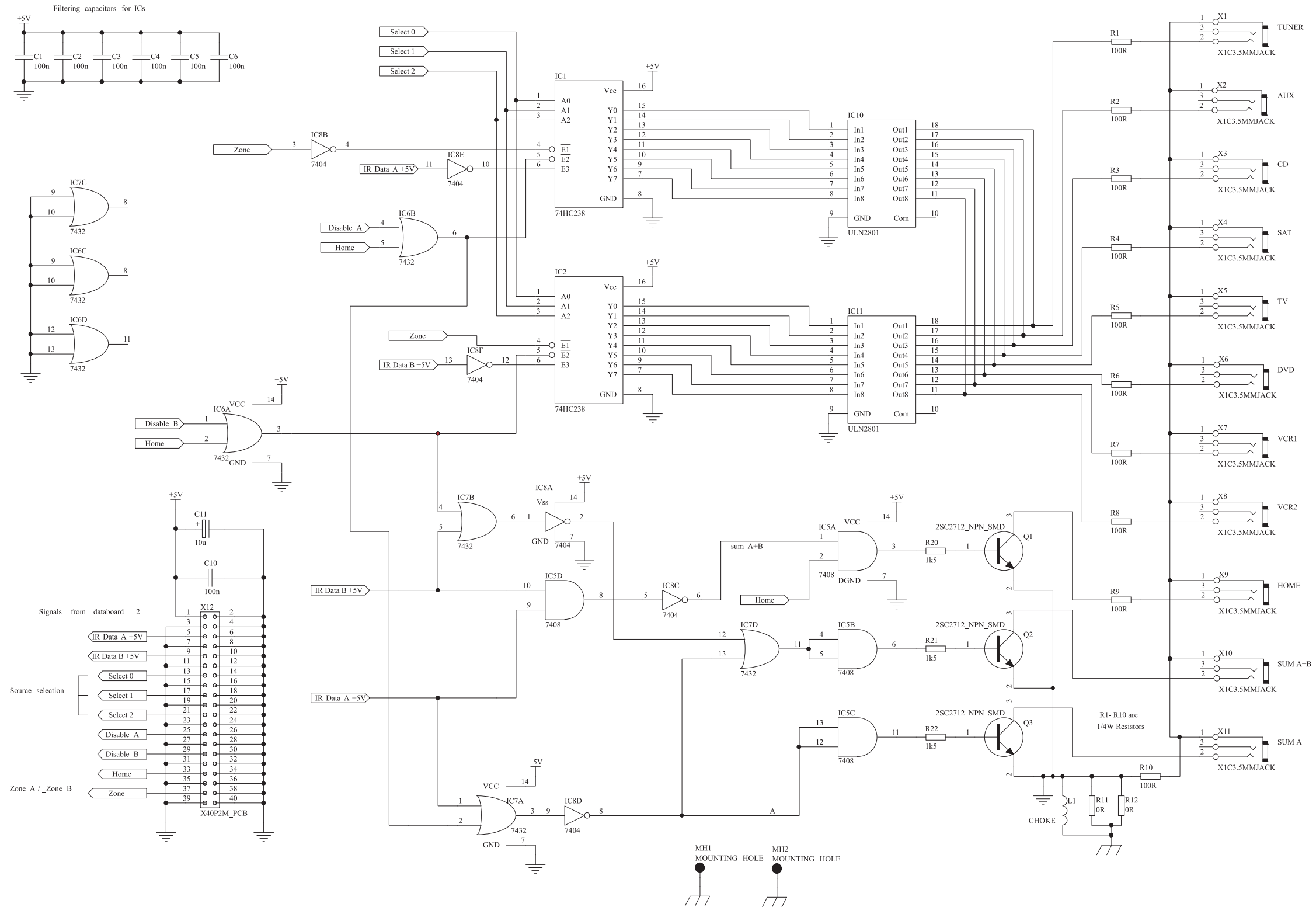

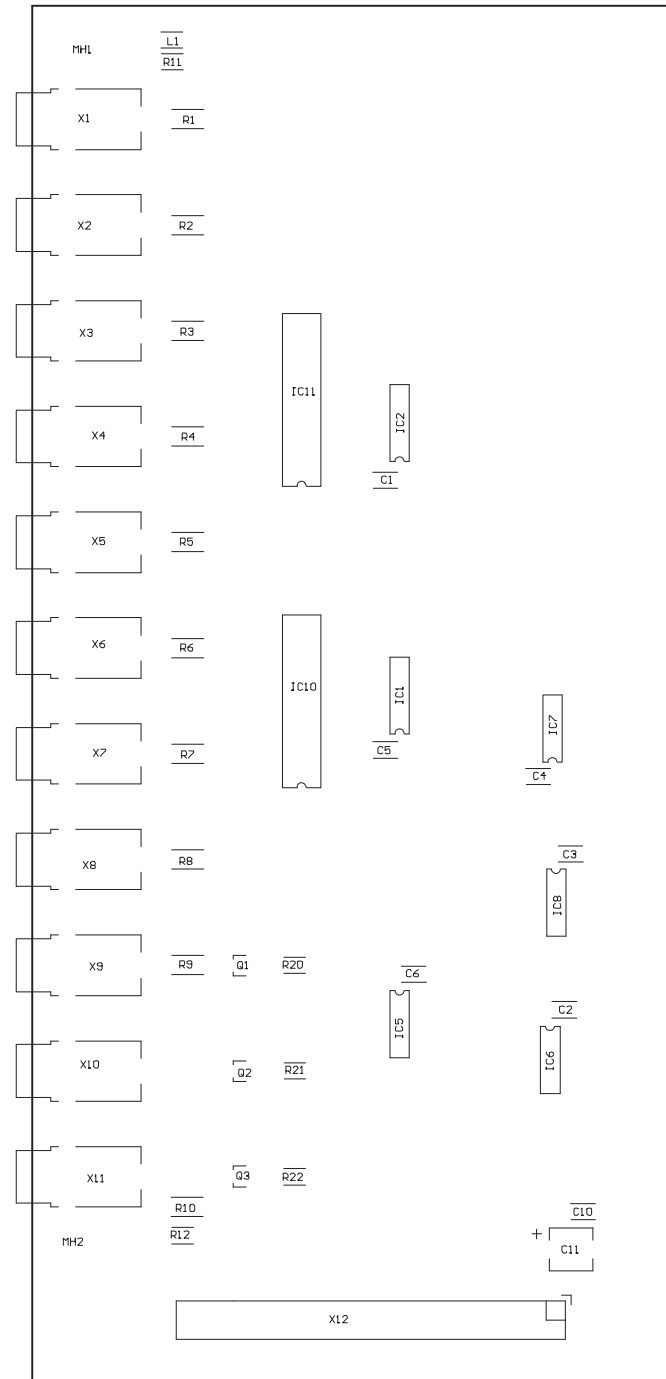

# 7 DIGITAL 320126

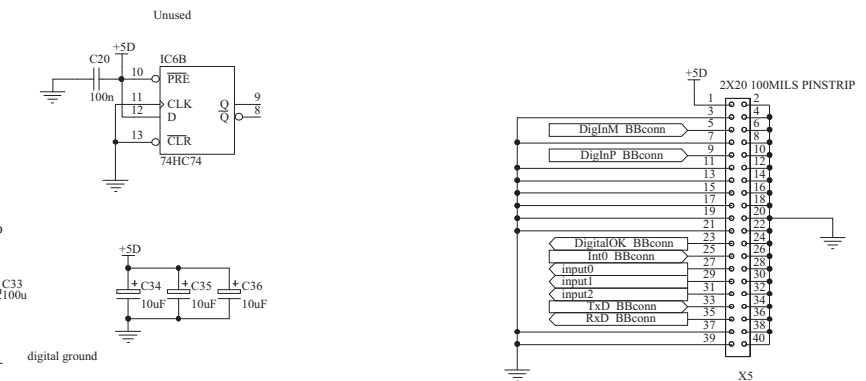
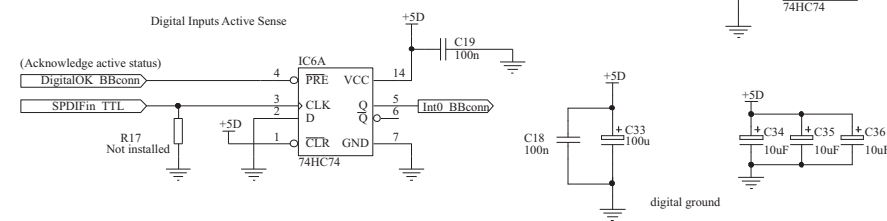
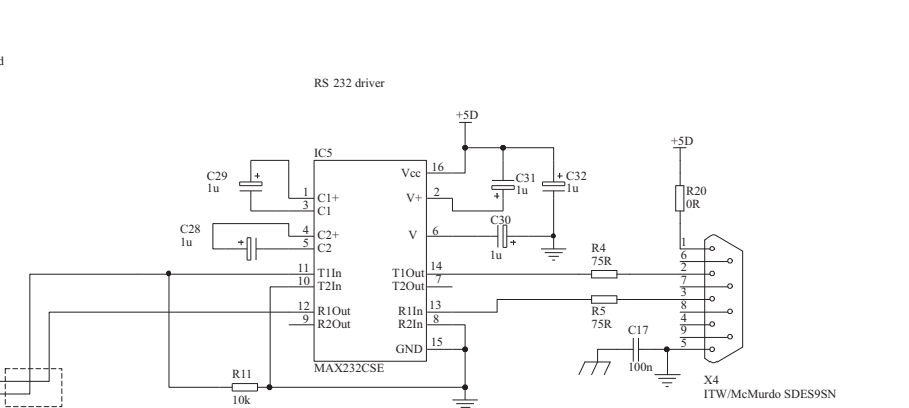
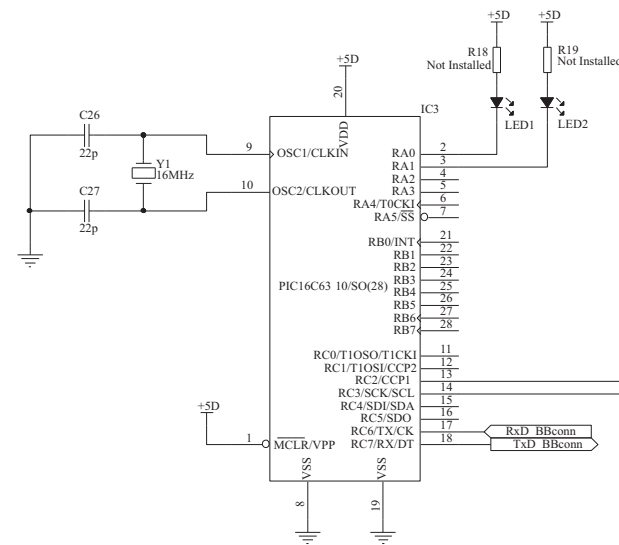
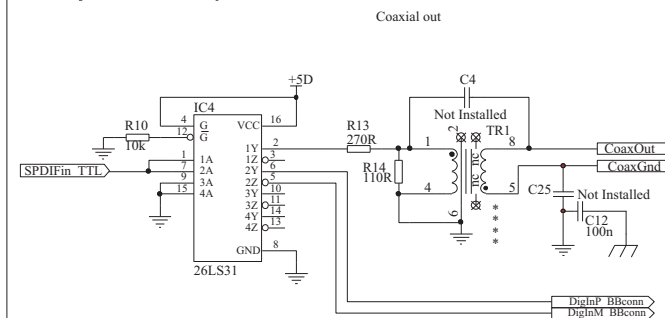
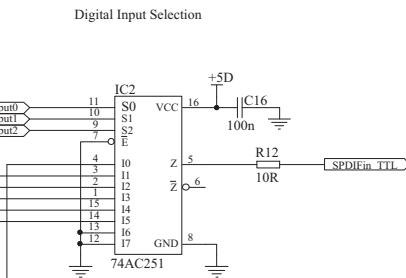
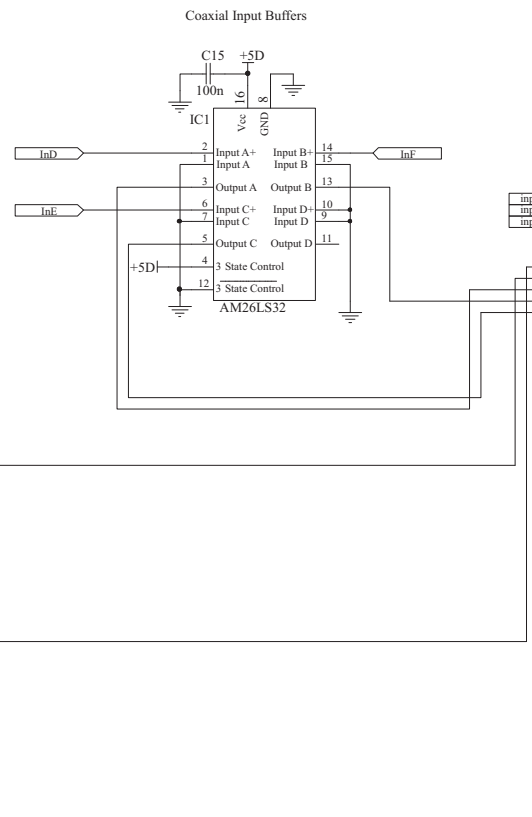
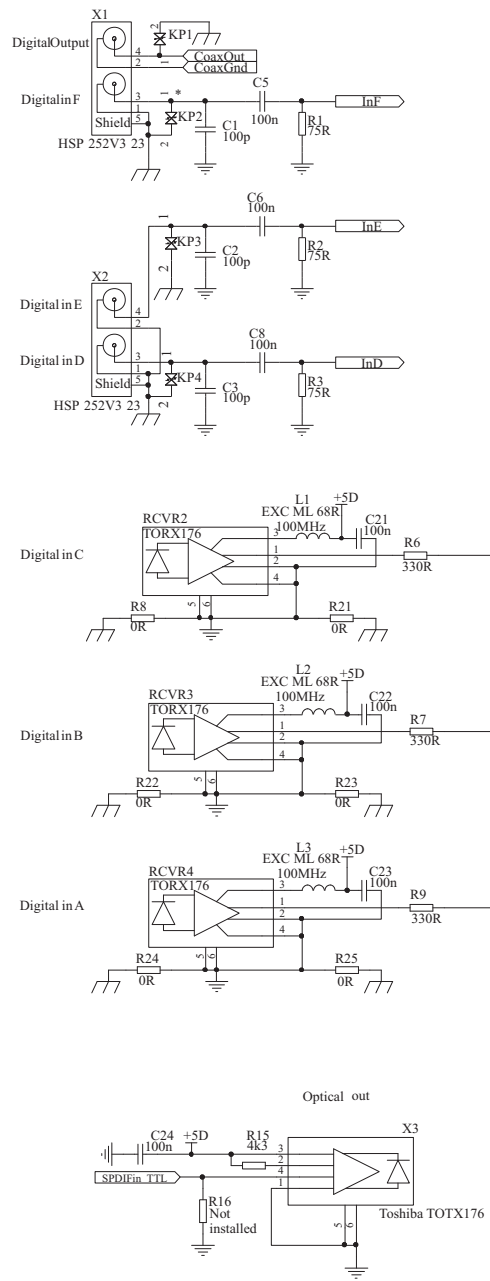

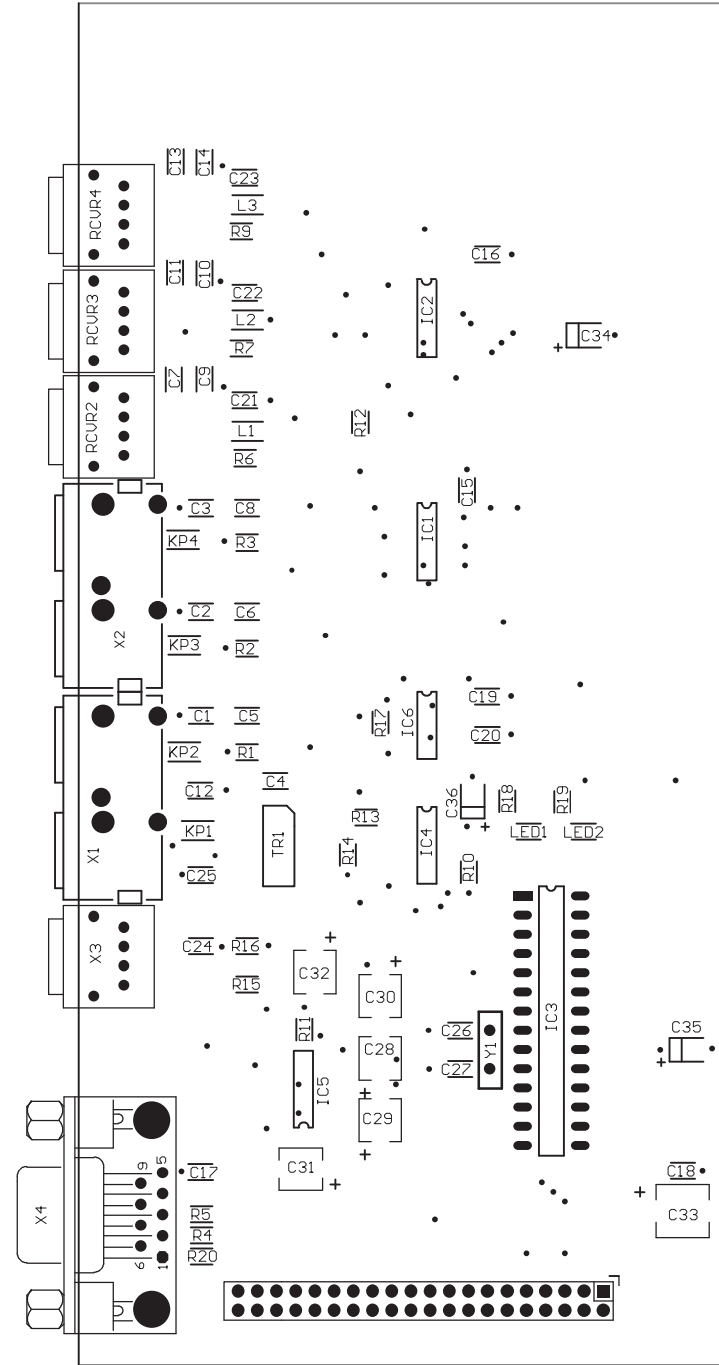

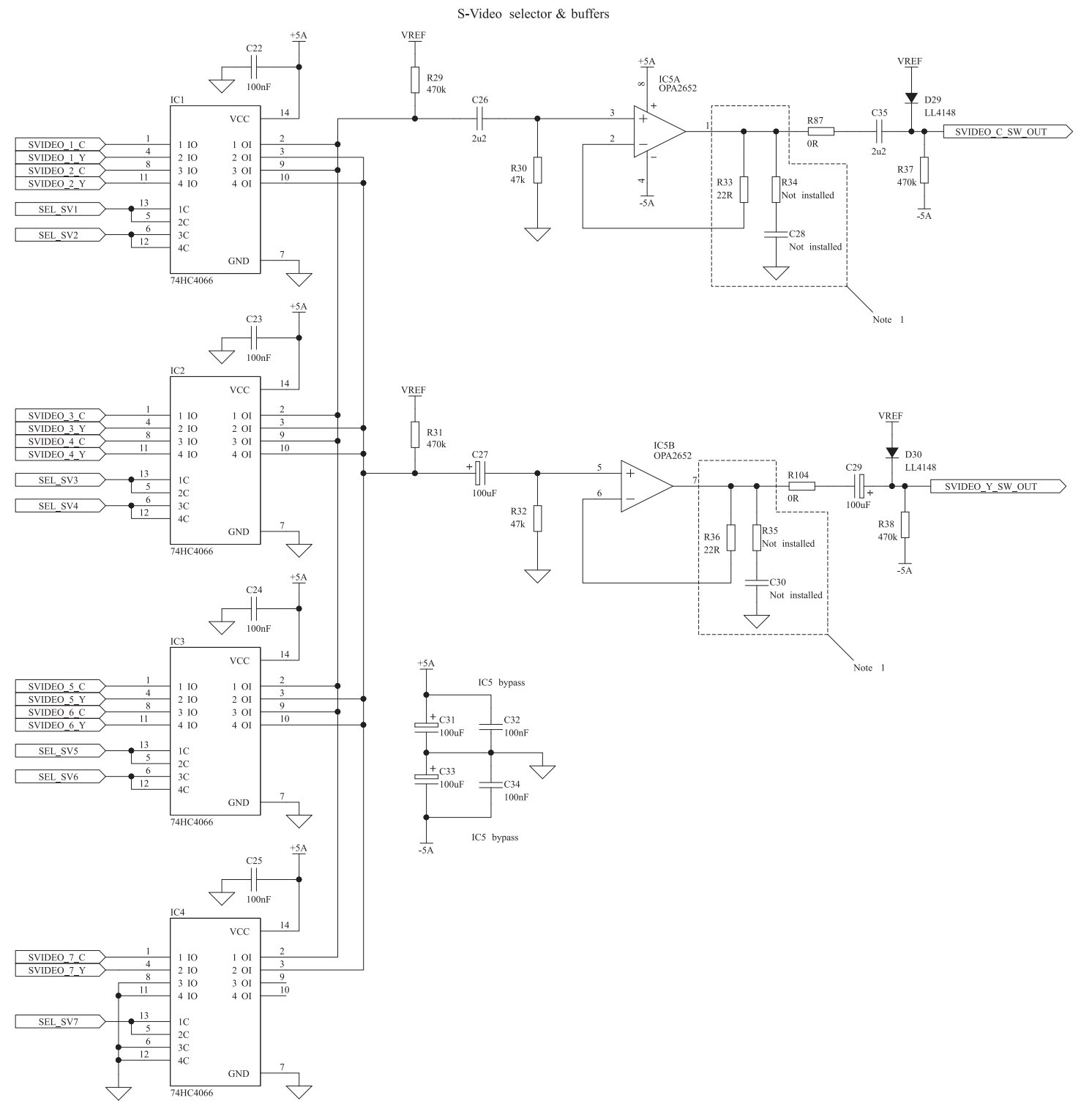
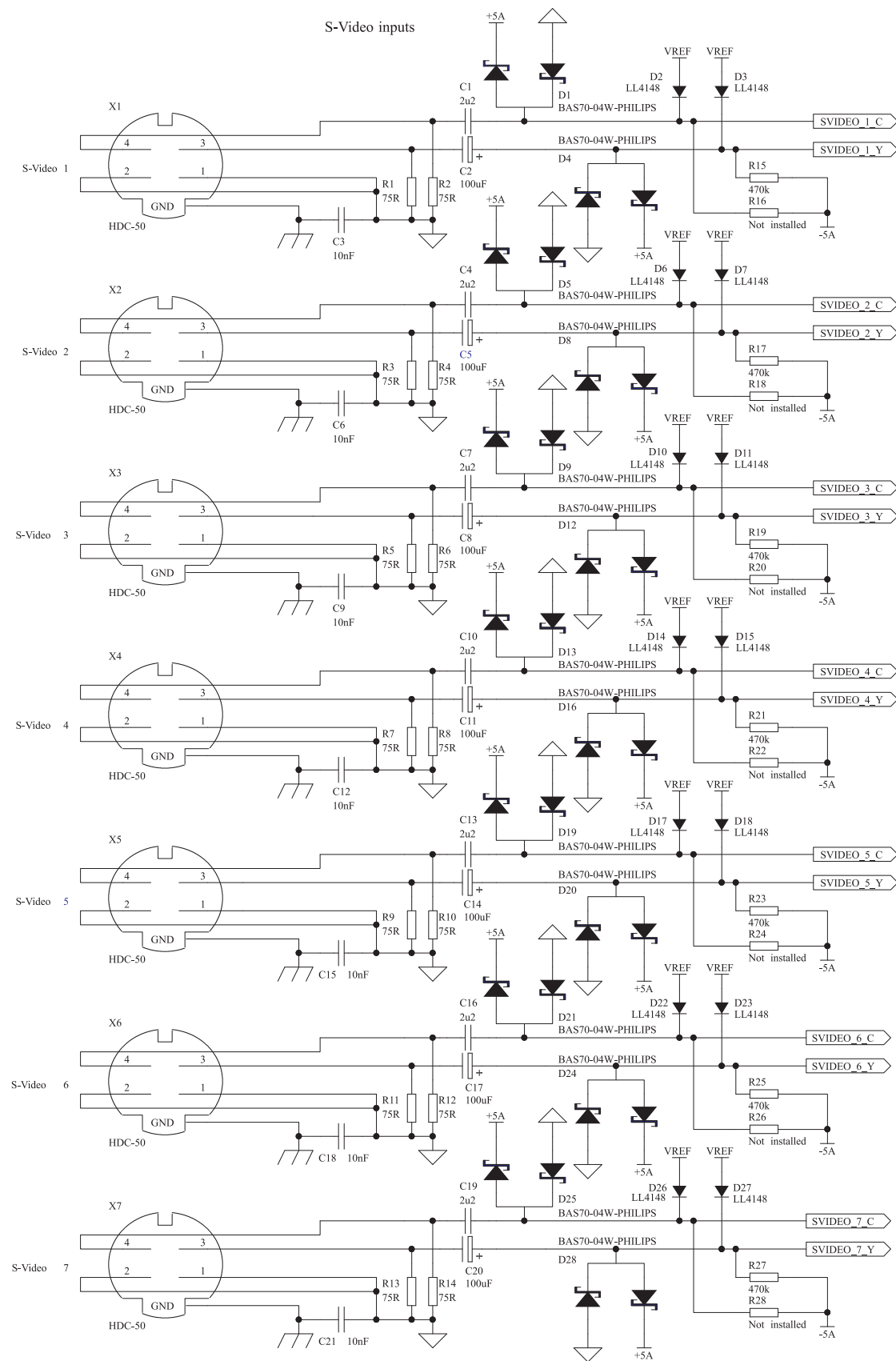

OSD Output Buffering And Switching

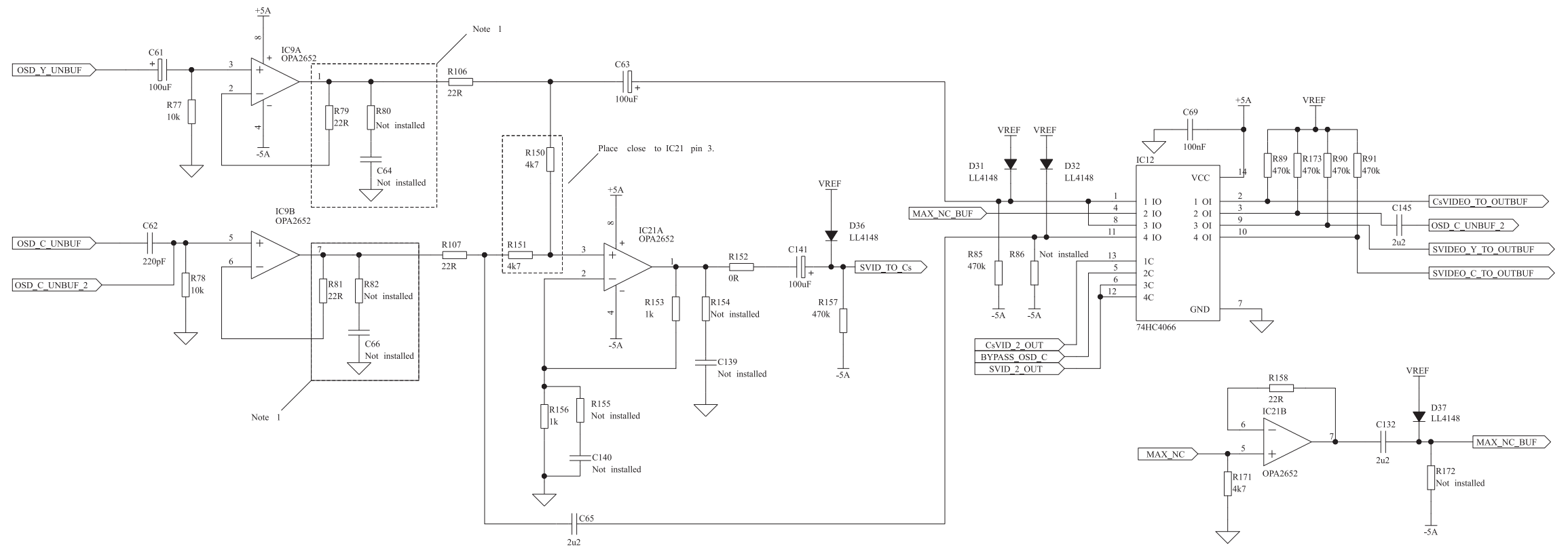

S-Video OSD out buffering

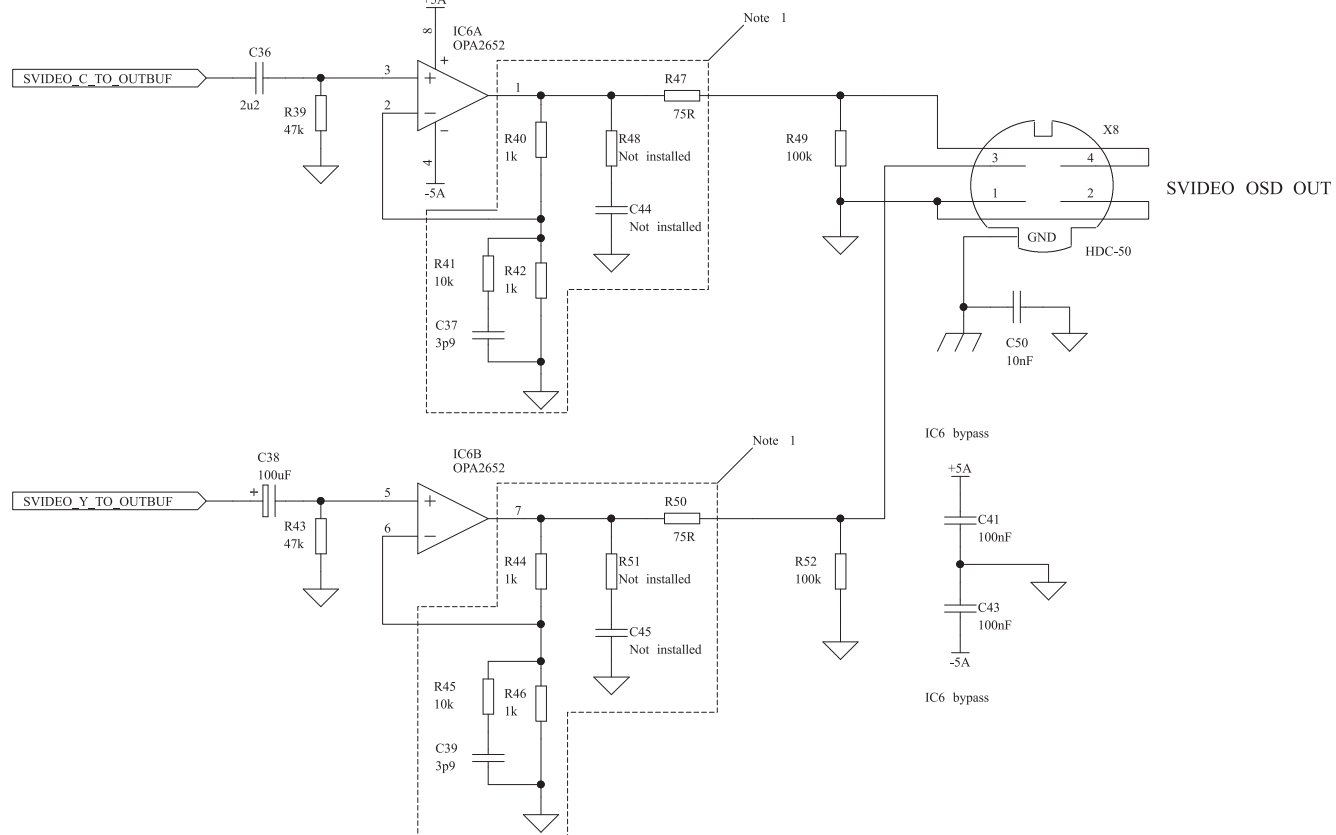

Video Signal Routing to OSD

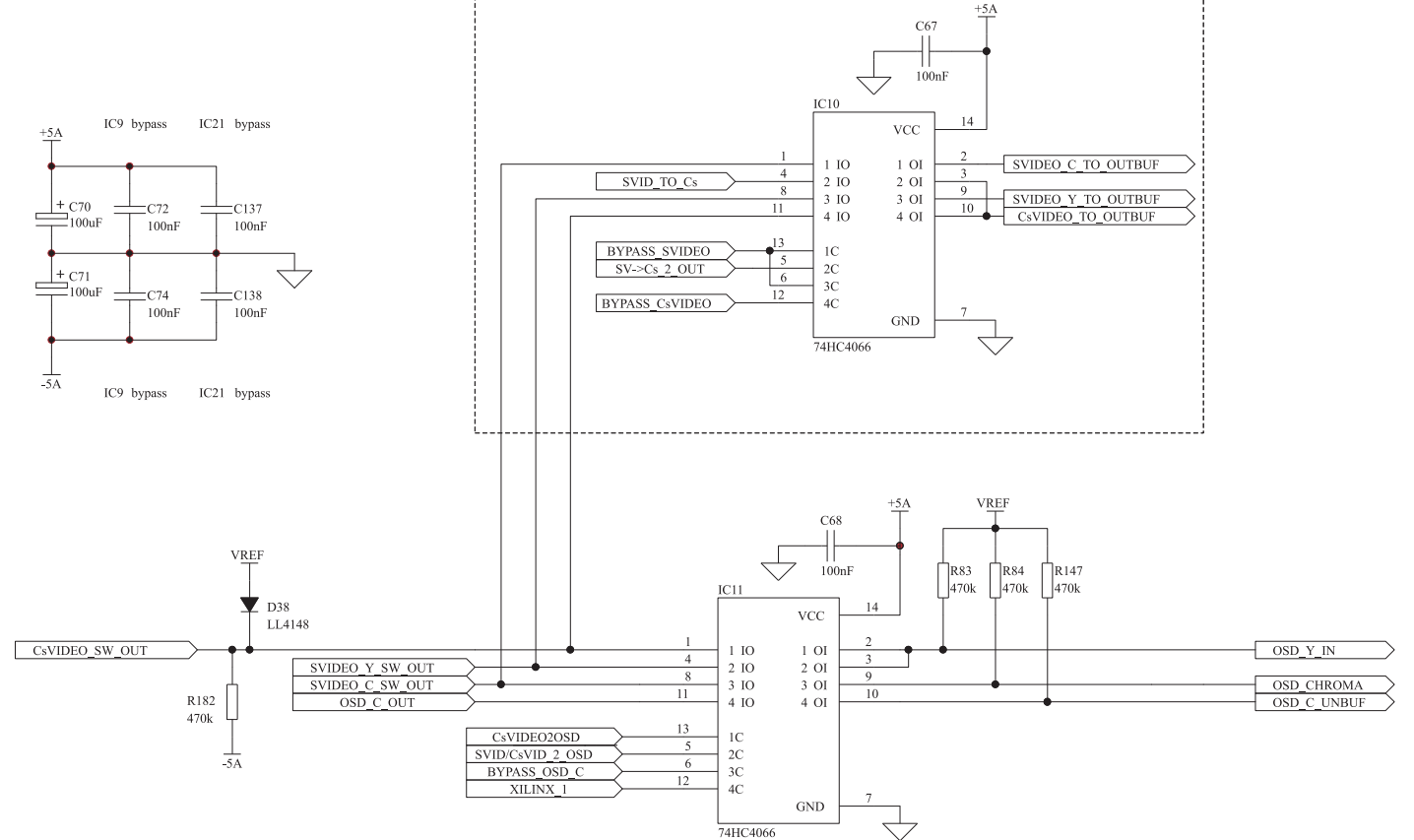

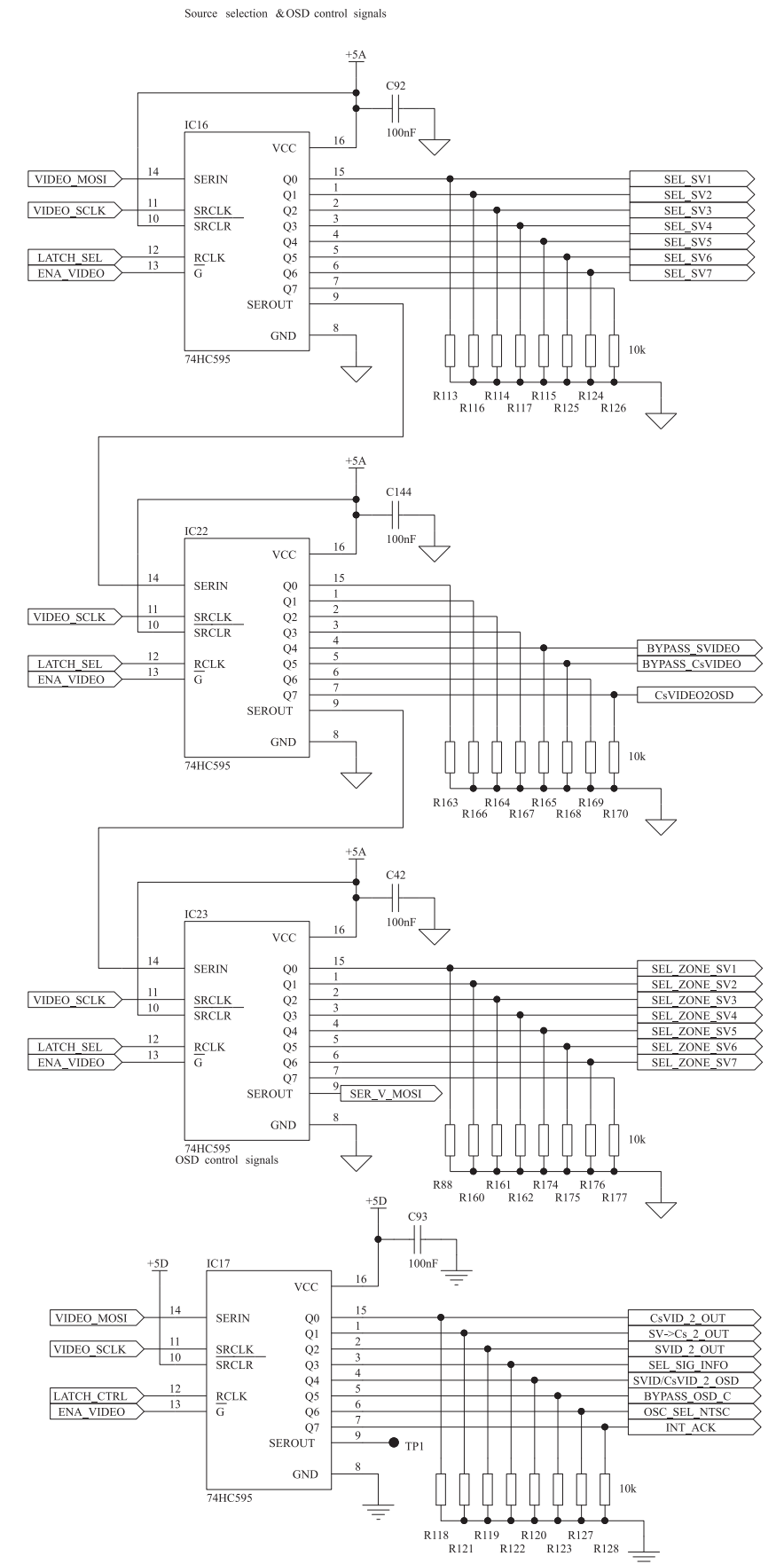
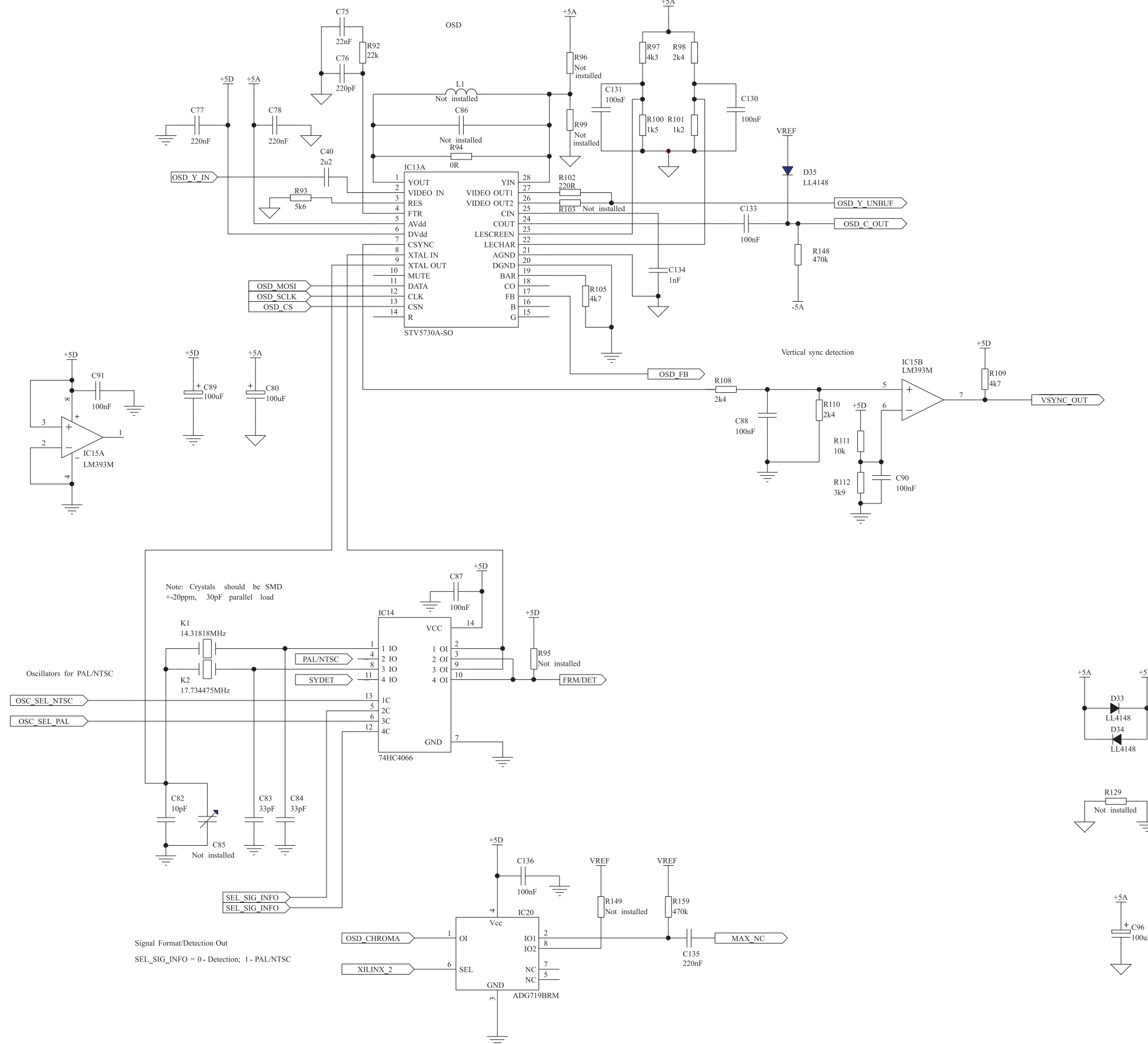



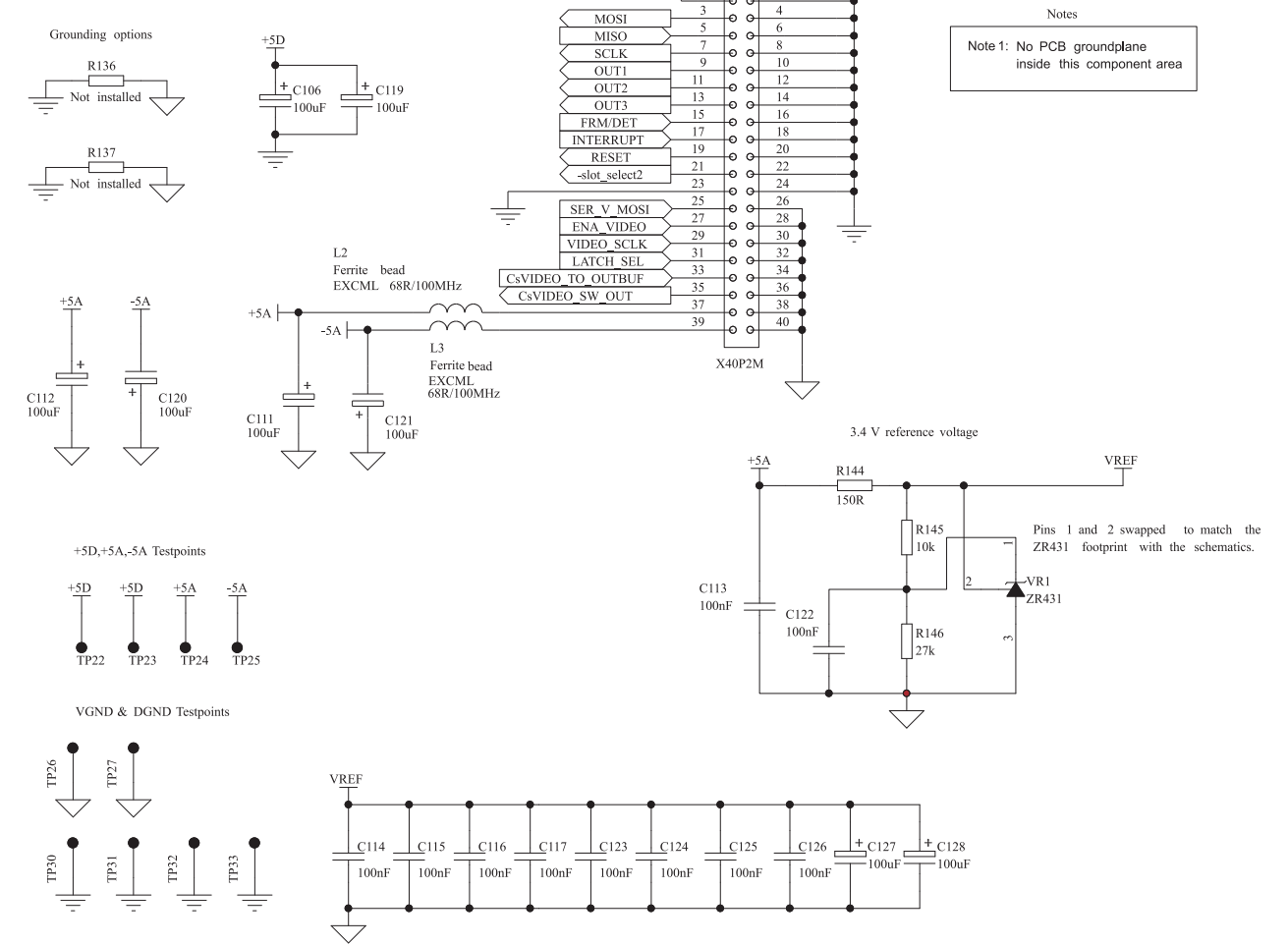
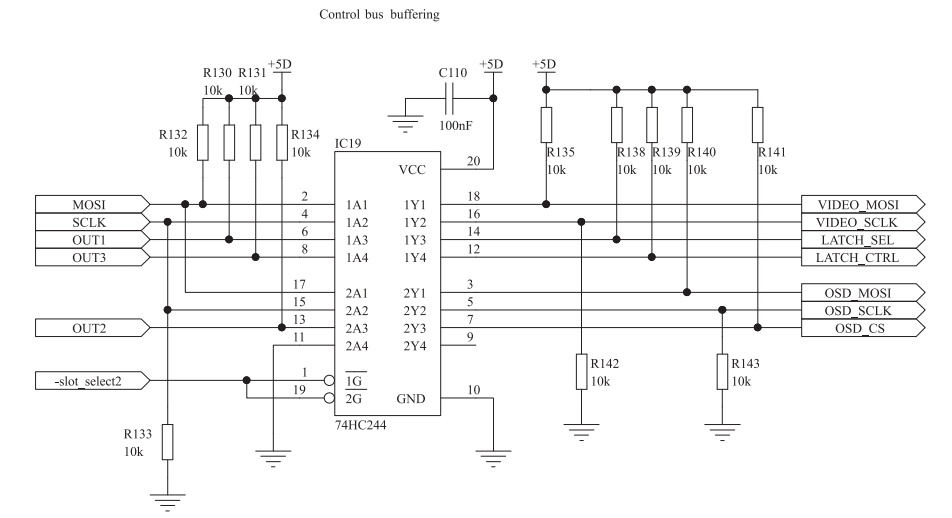
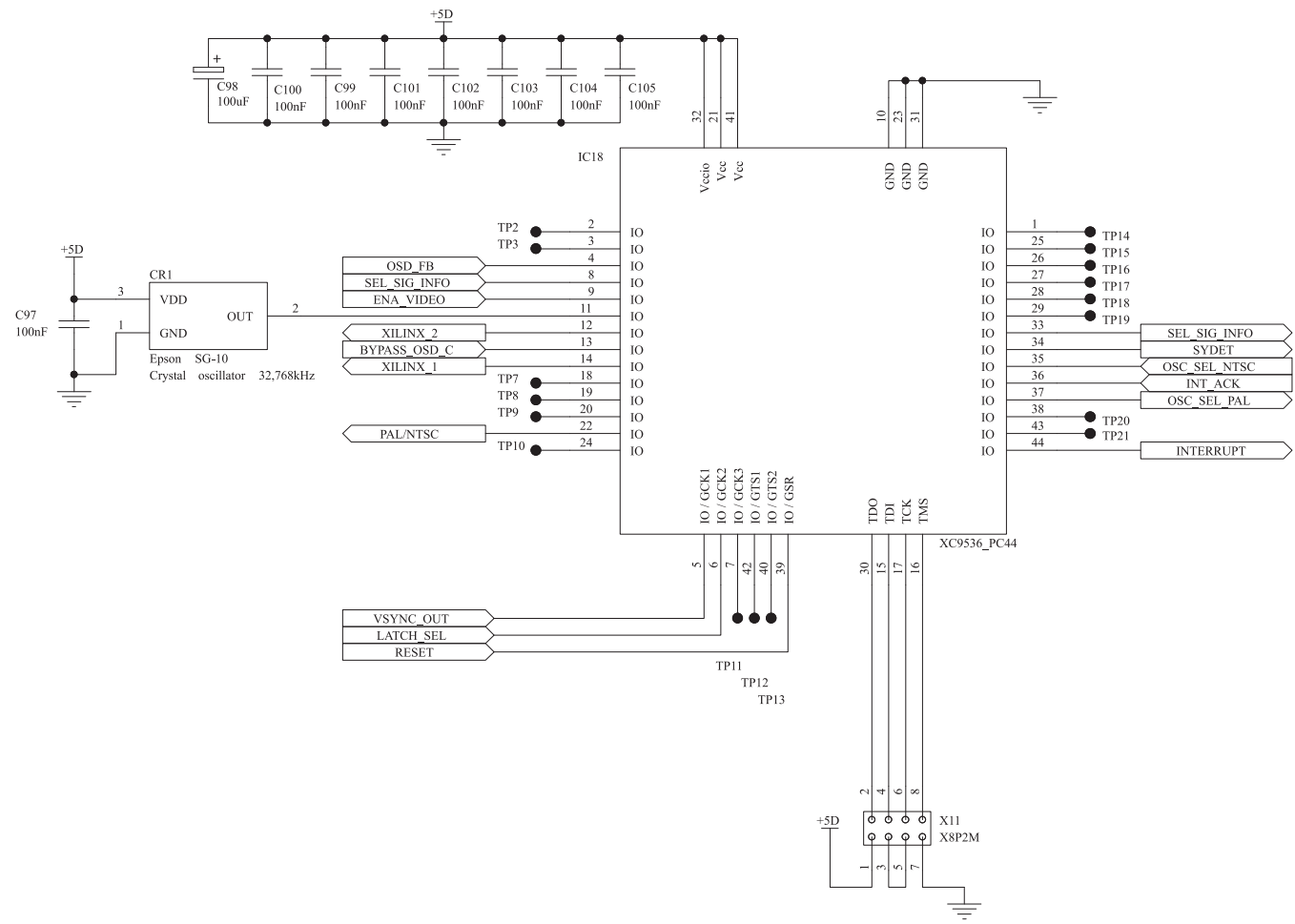

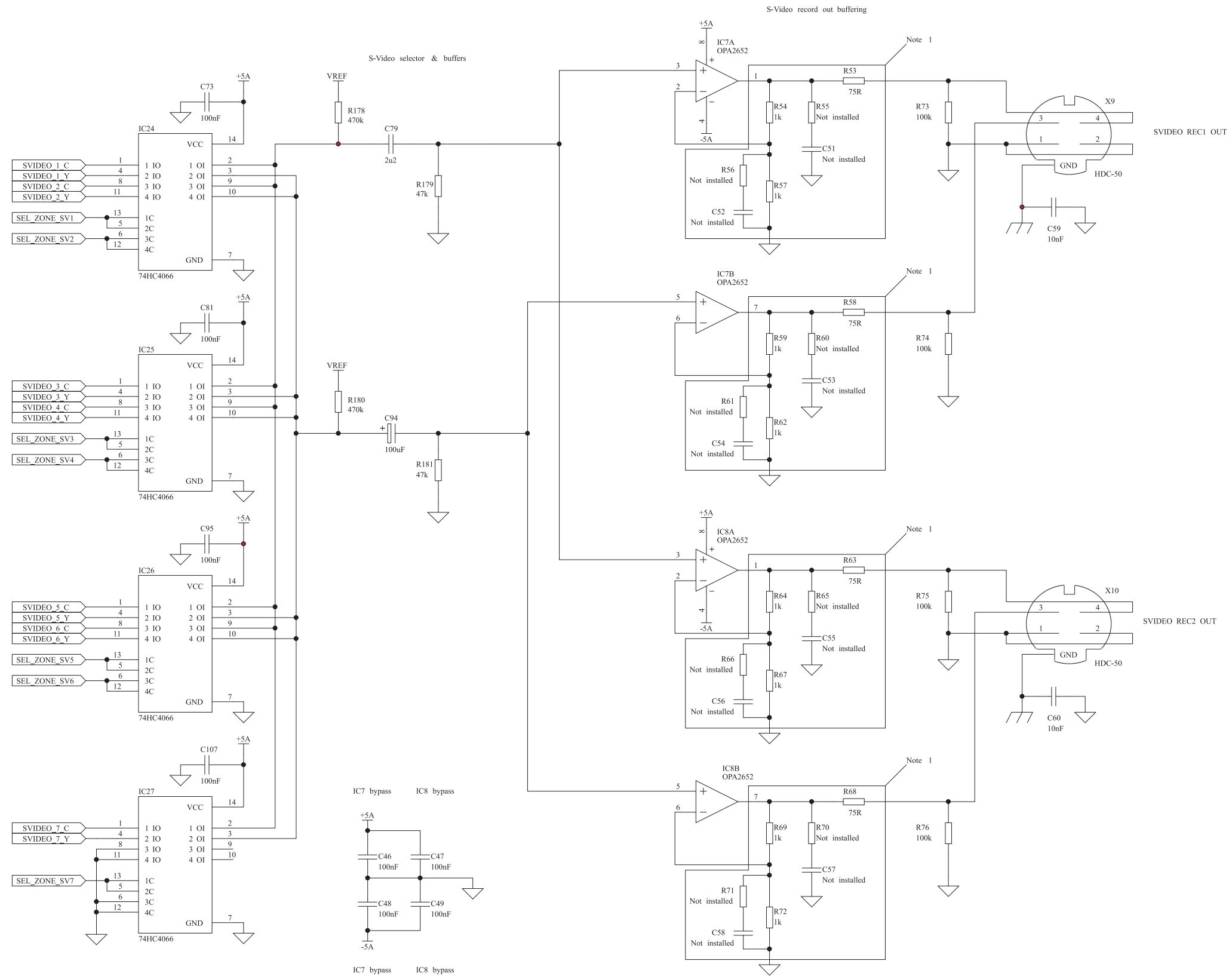

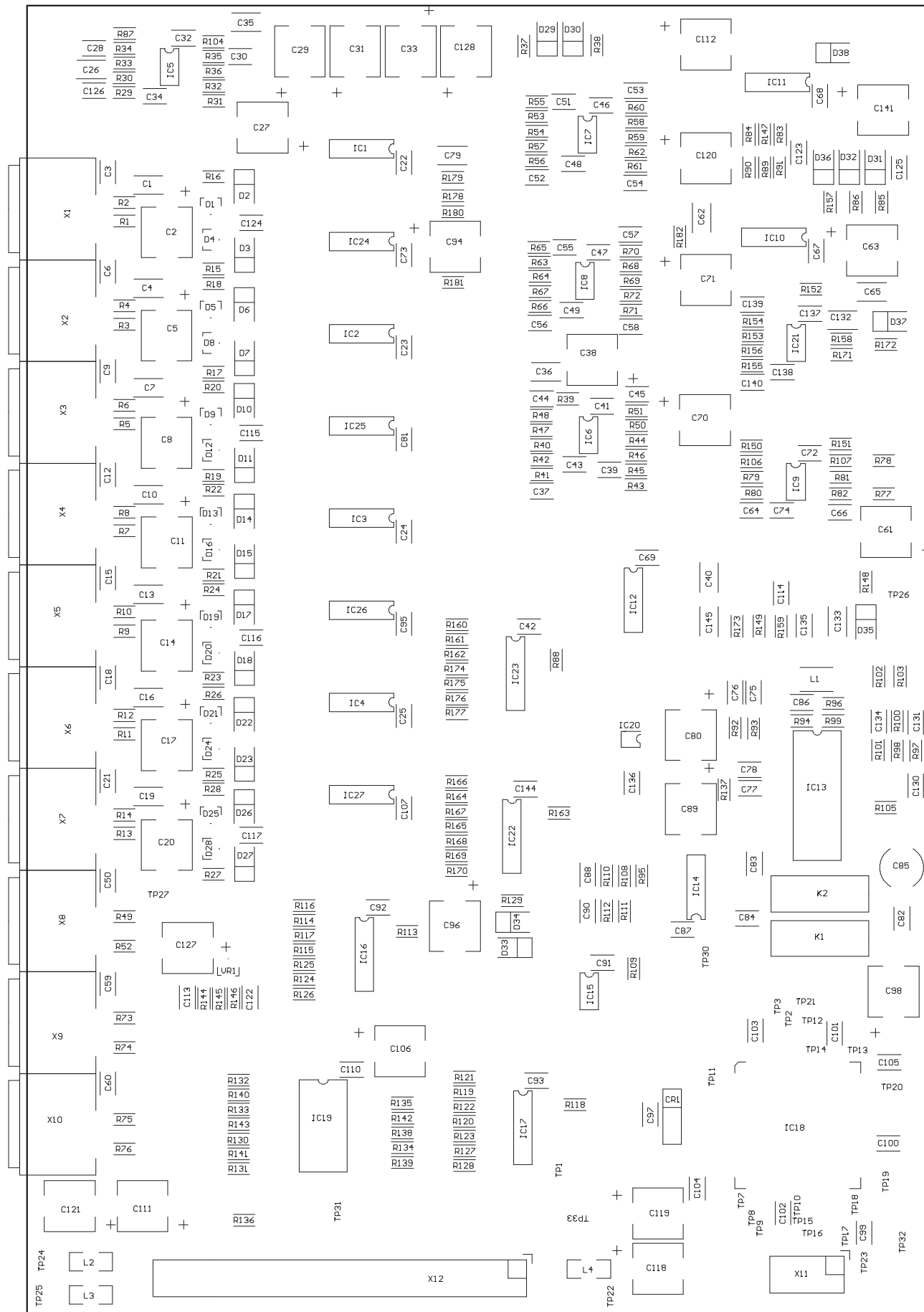

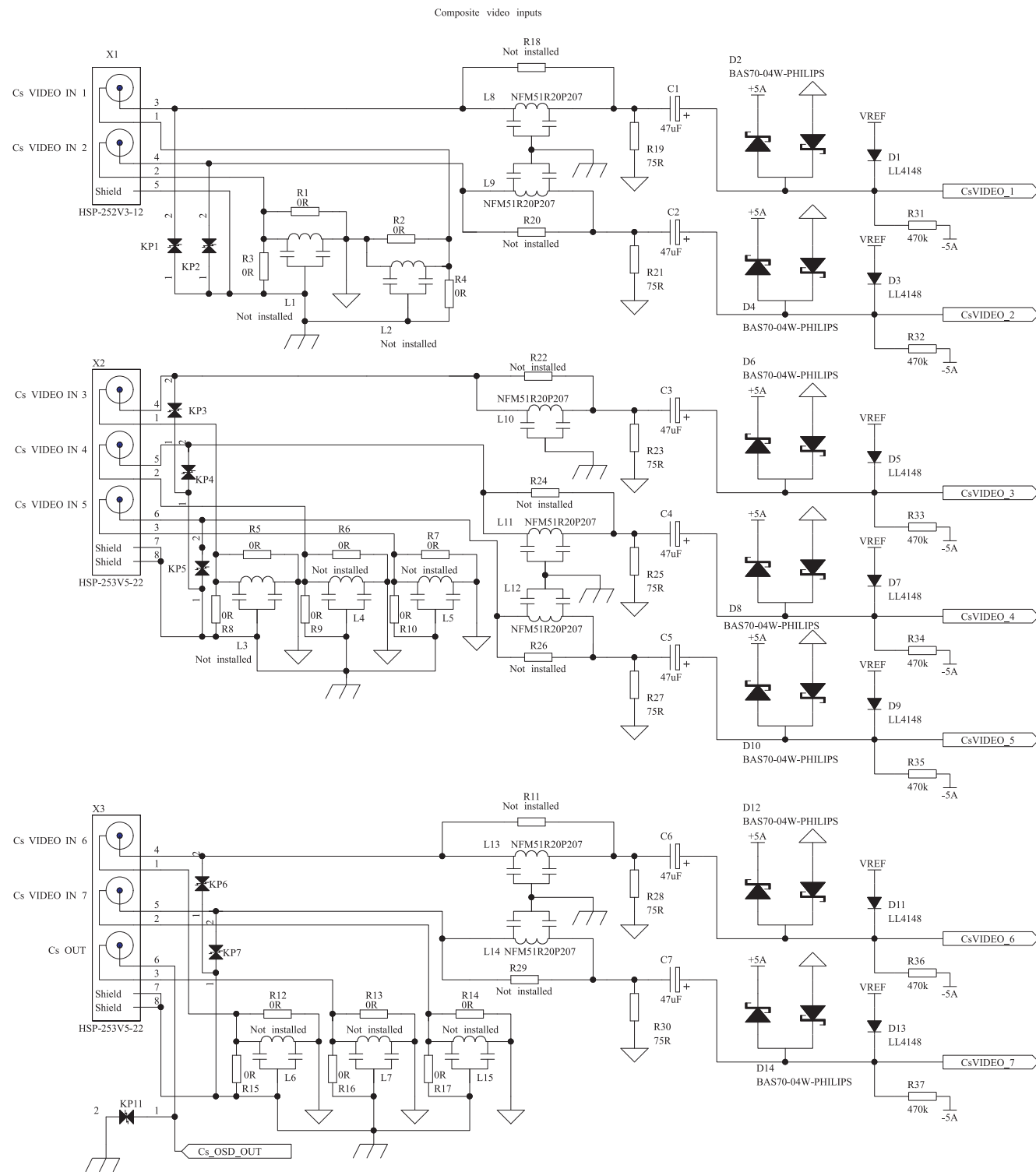

Composite video selectors & buffers

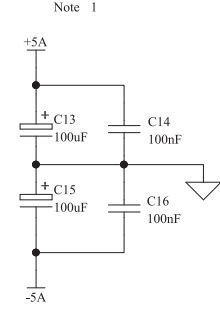
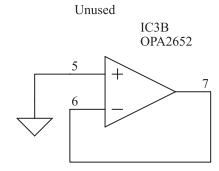
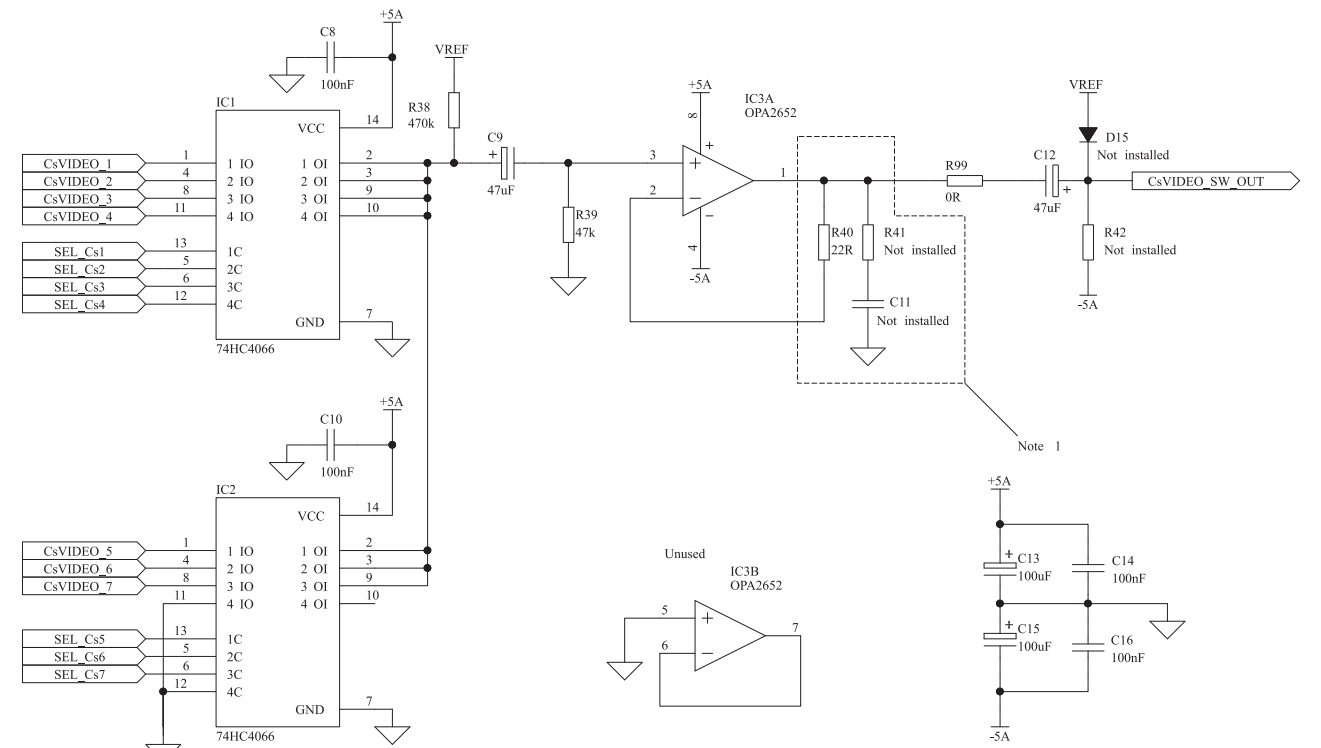

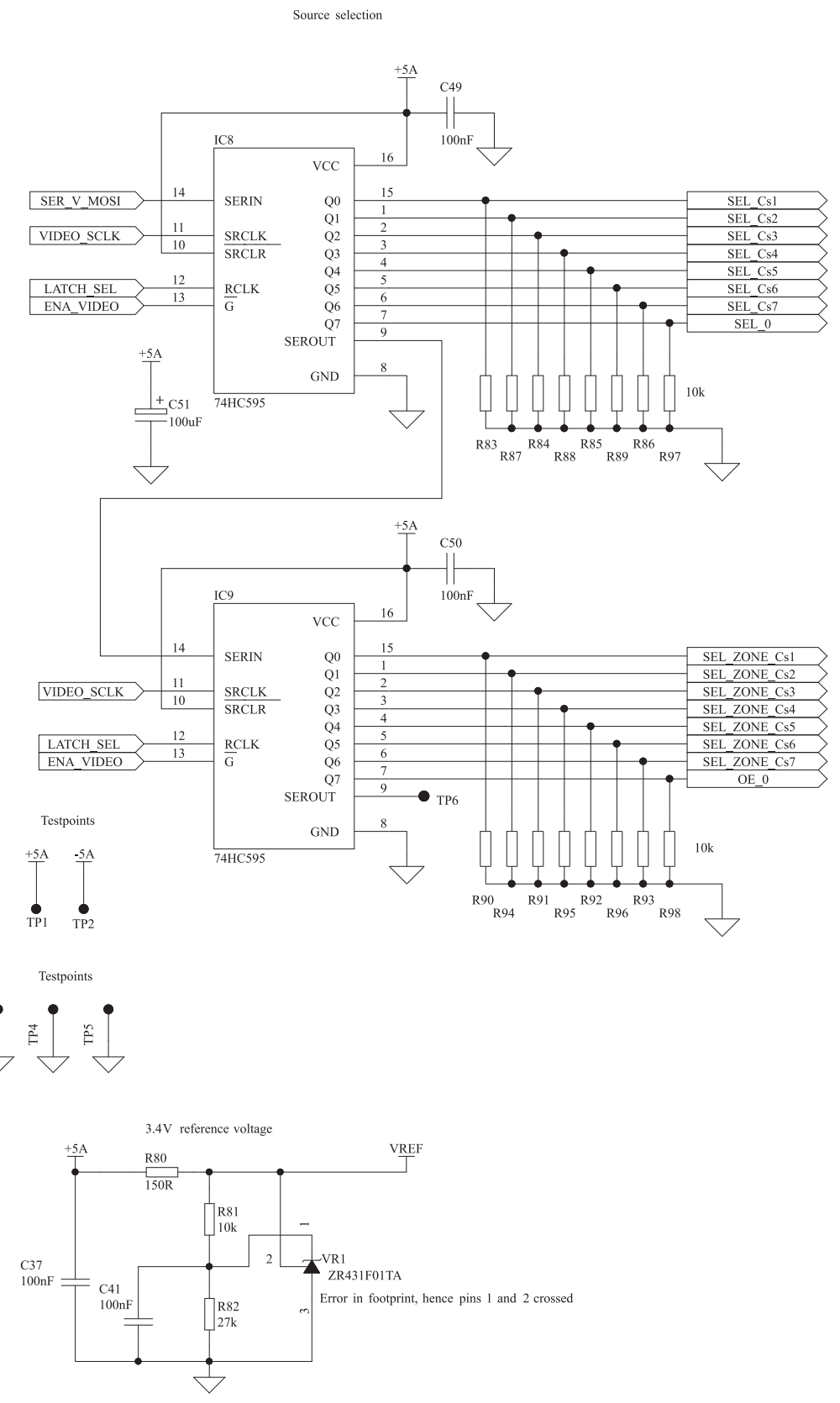
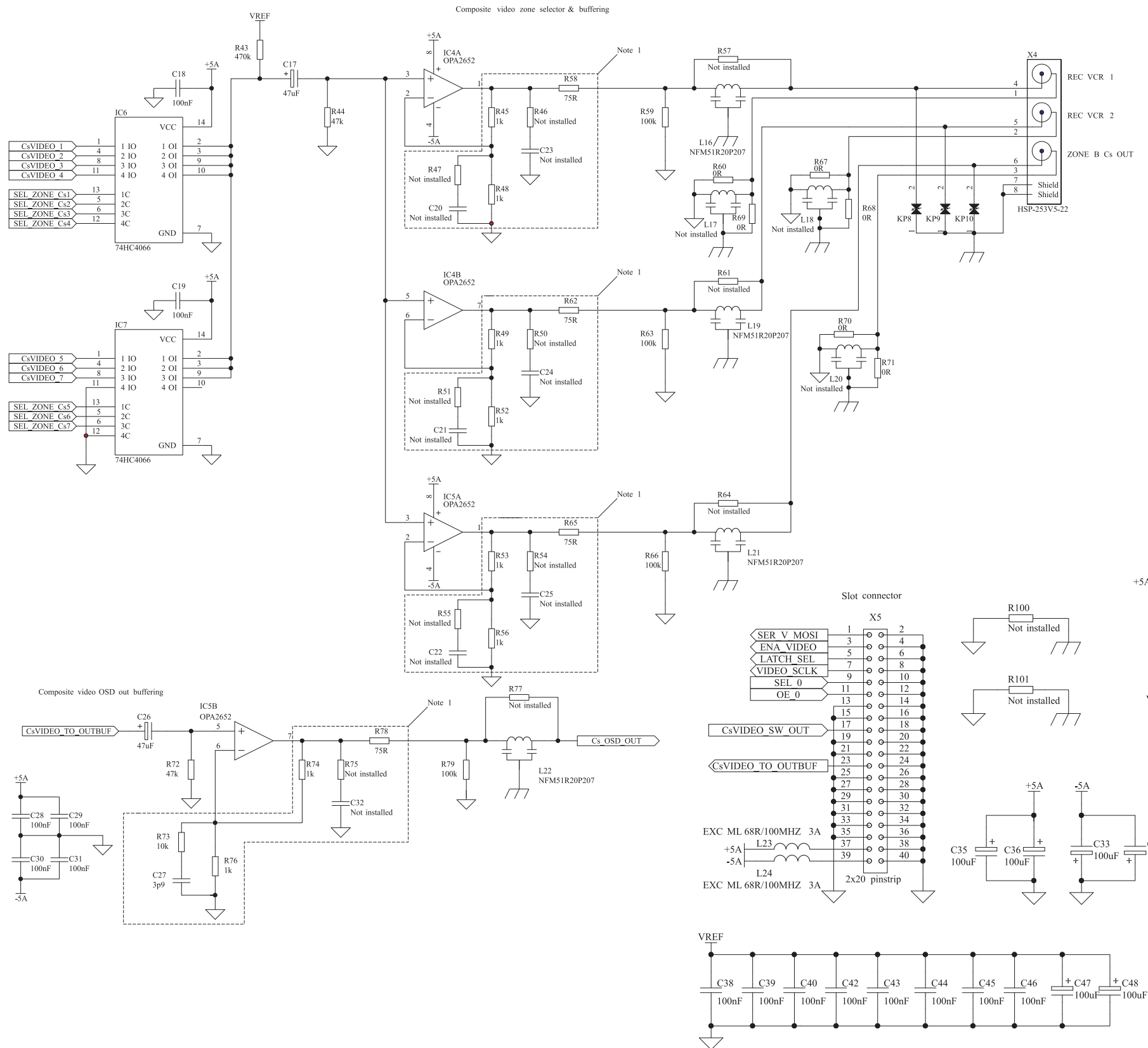

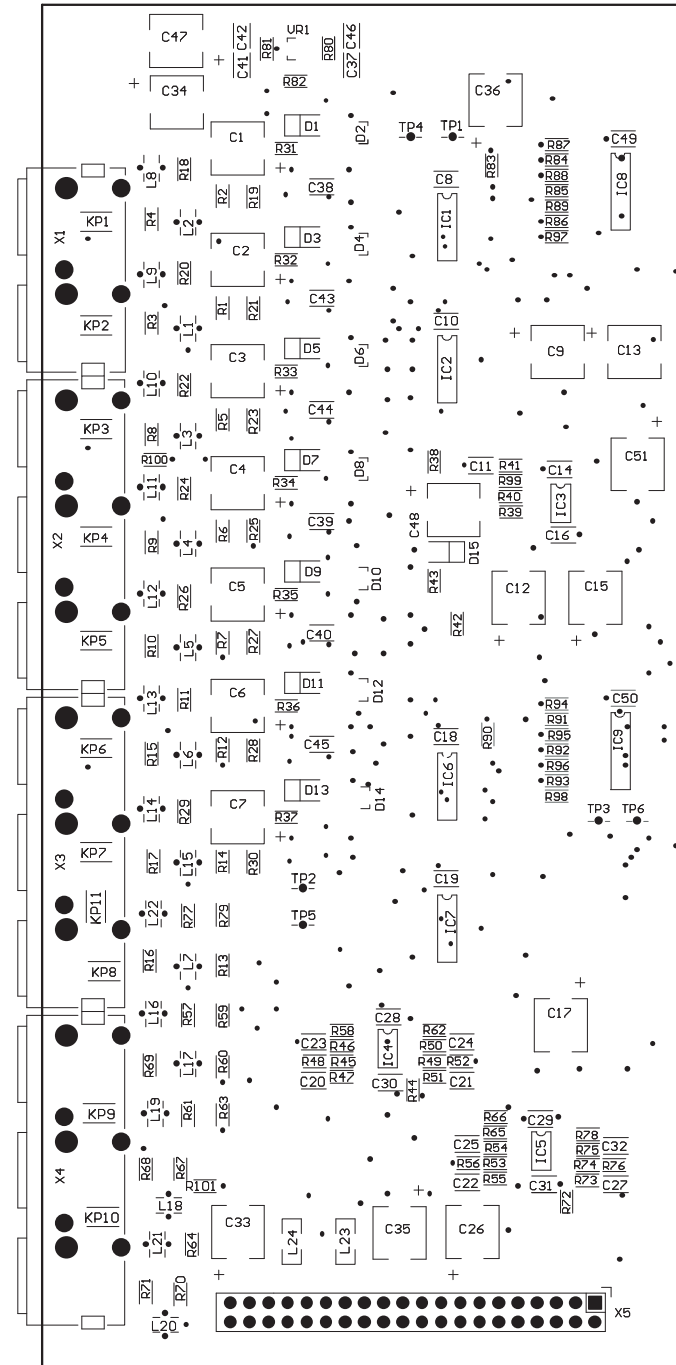

10 MAIN AUDIO 320165 SH 1 OF 7

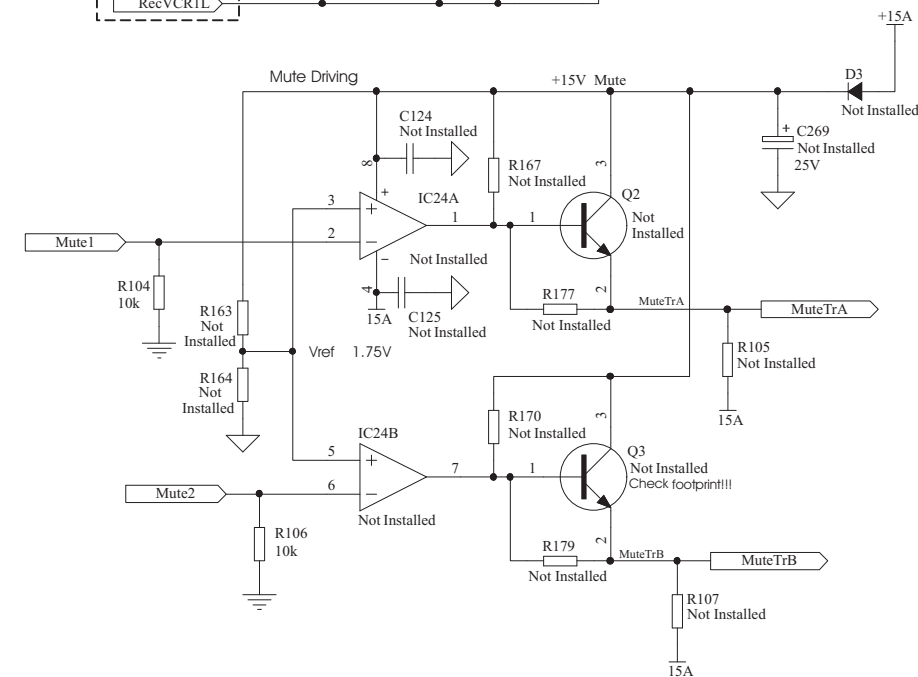
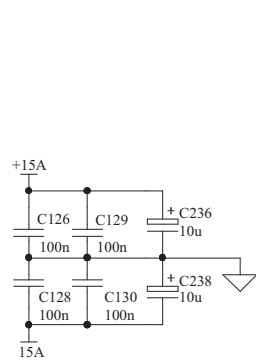
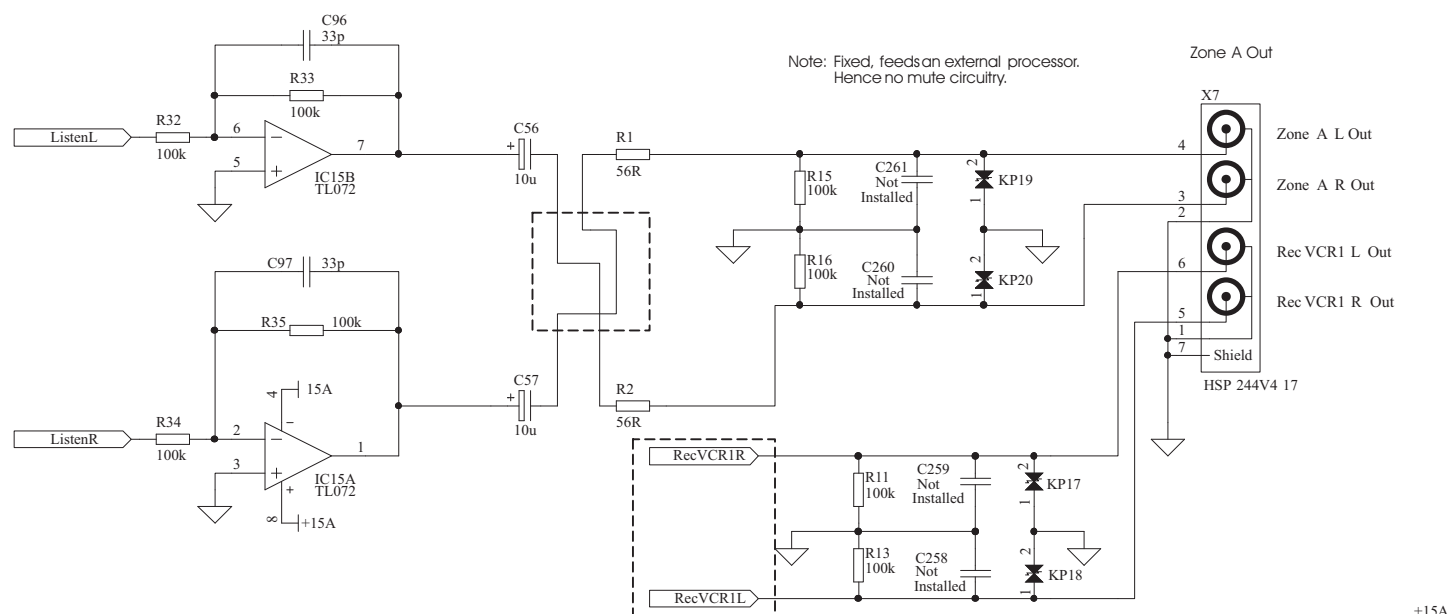
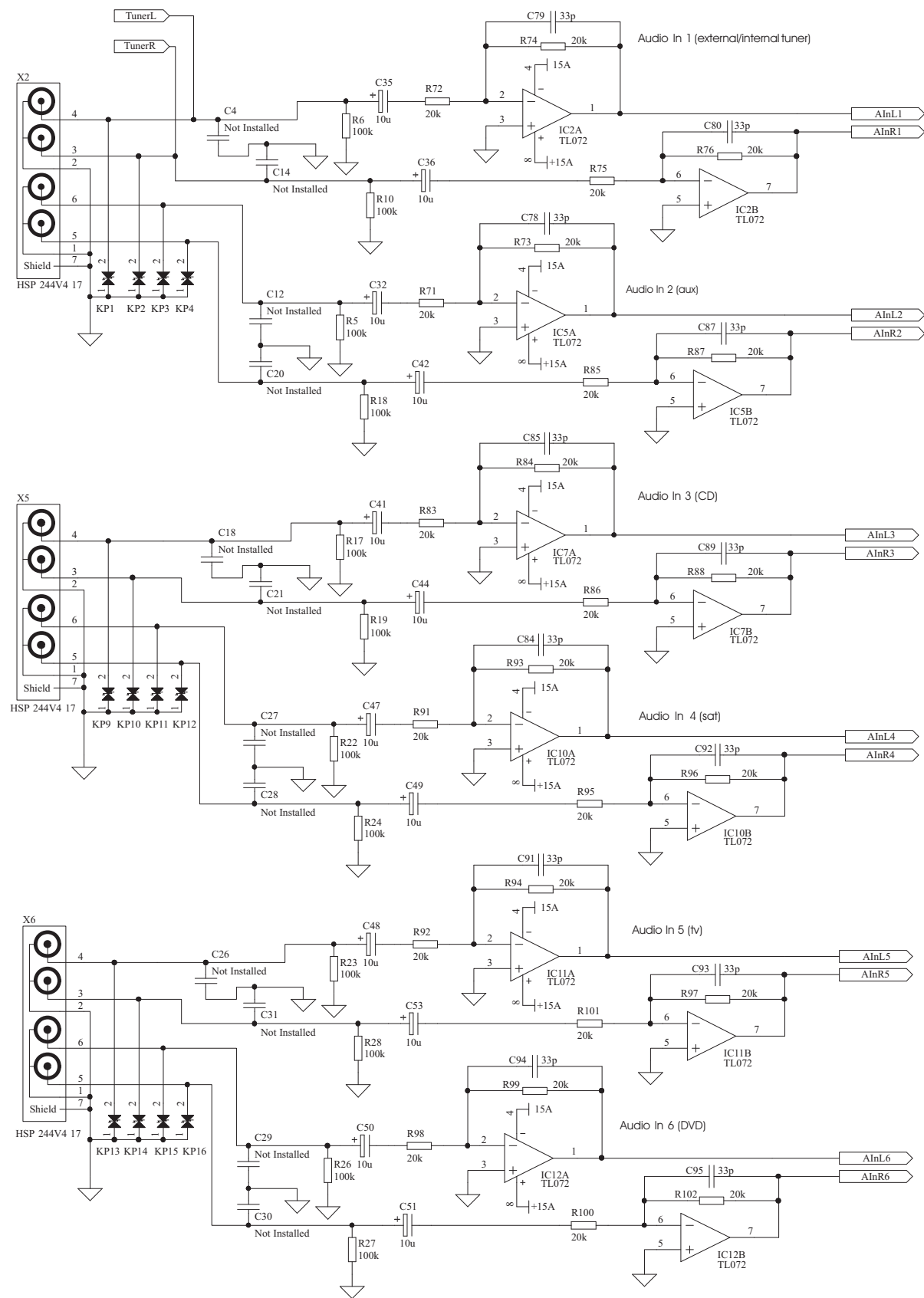

**10** MAIN AUDIO 320165 SH 2 OF 7

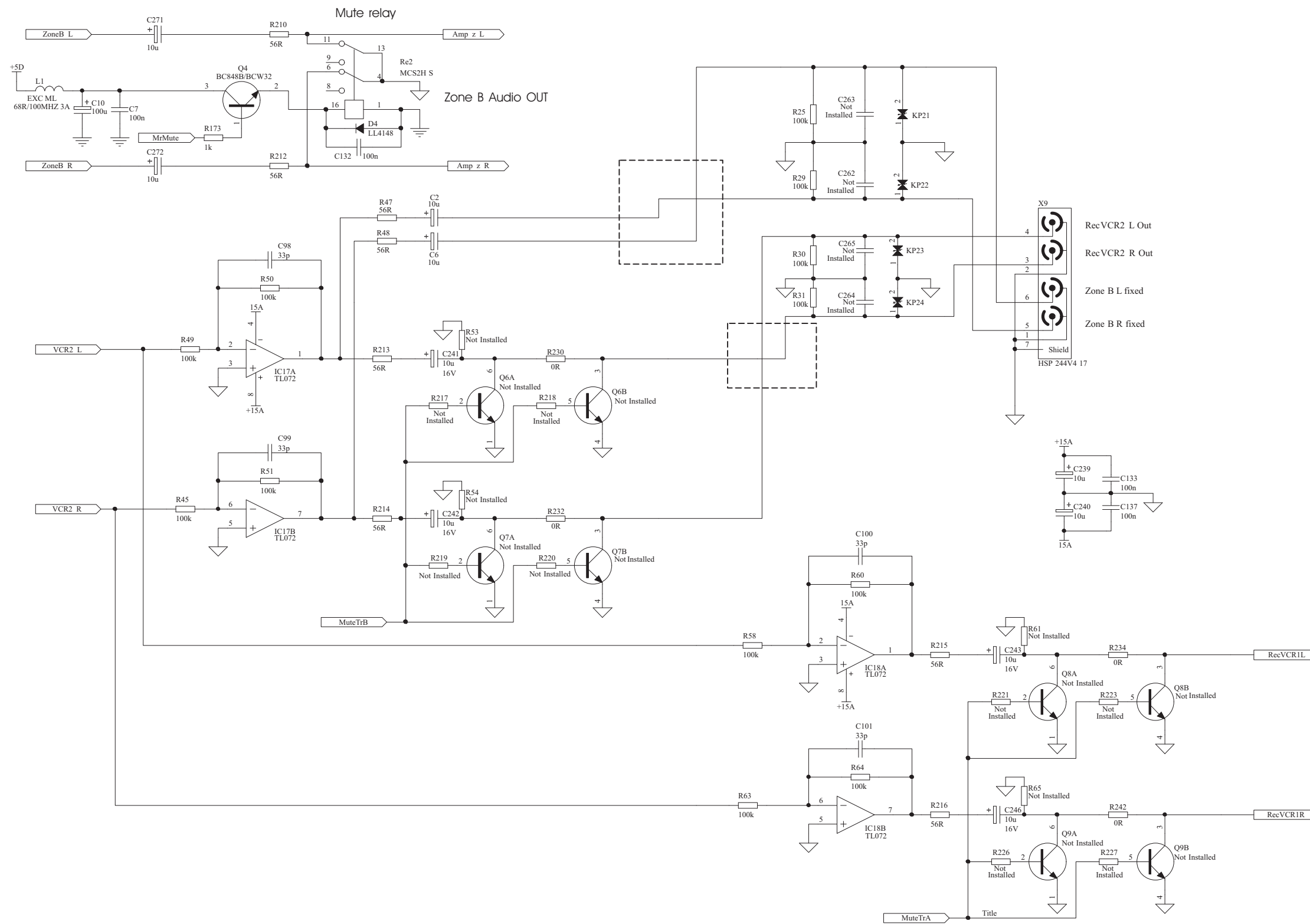



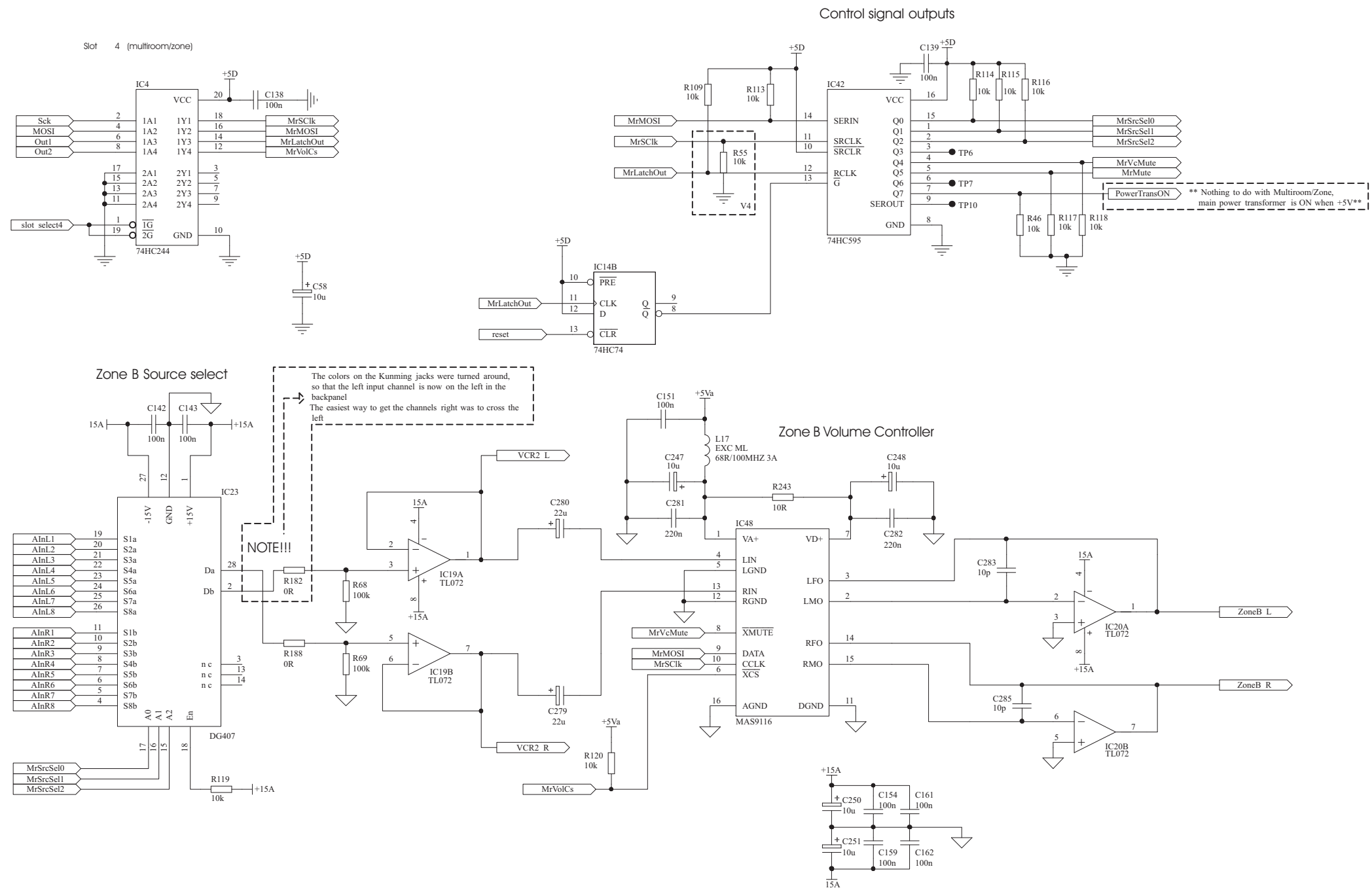

# 10 MAIN AUDIO 320165 SH 4 OF 7

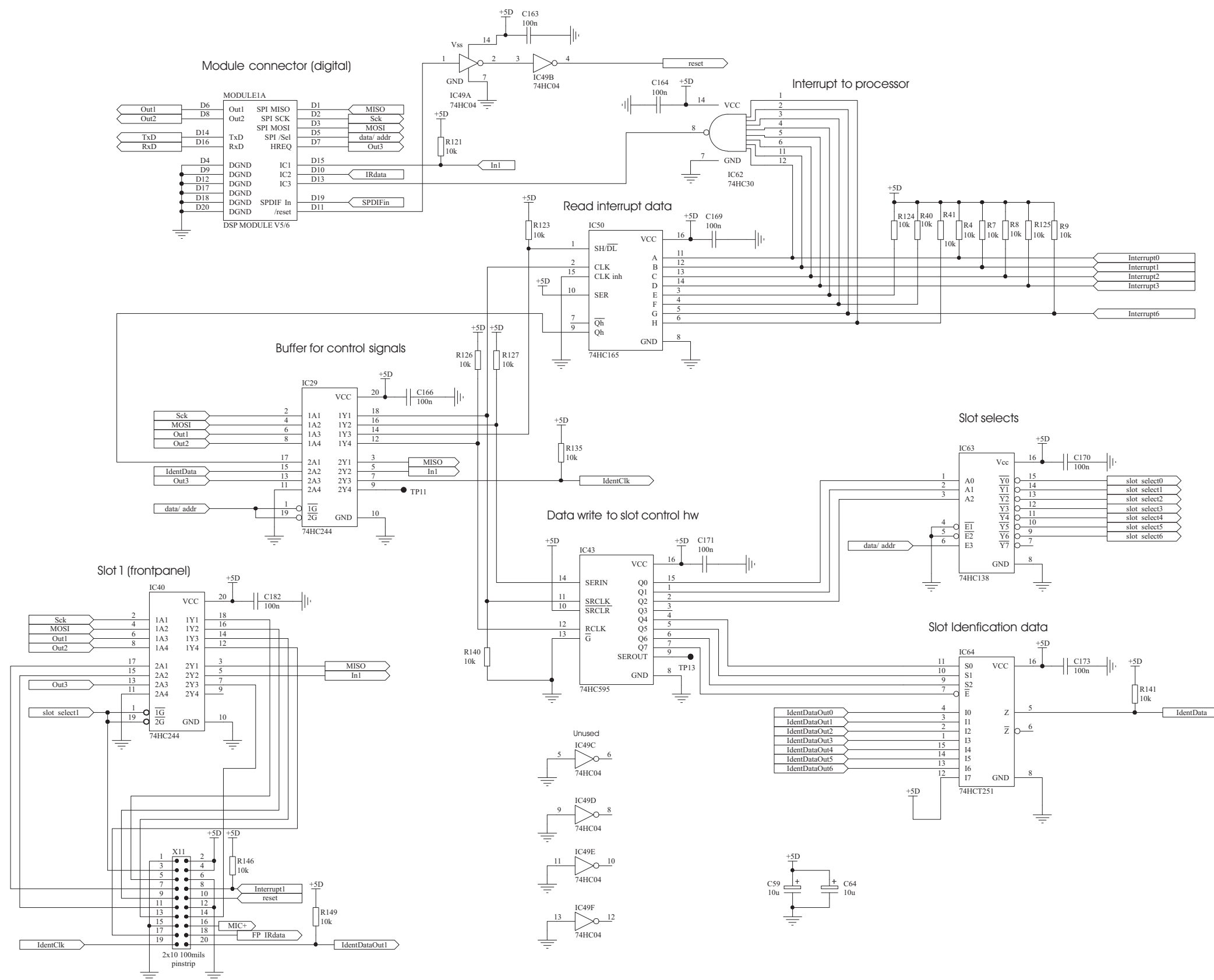

Motherboard data write

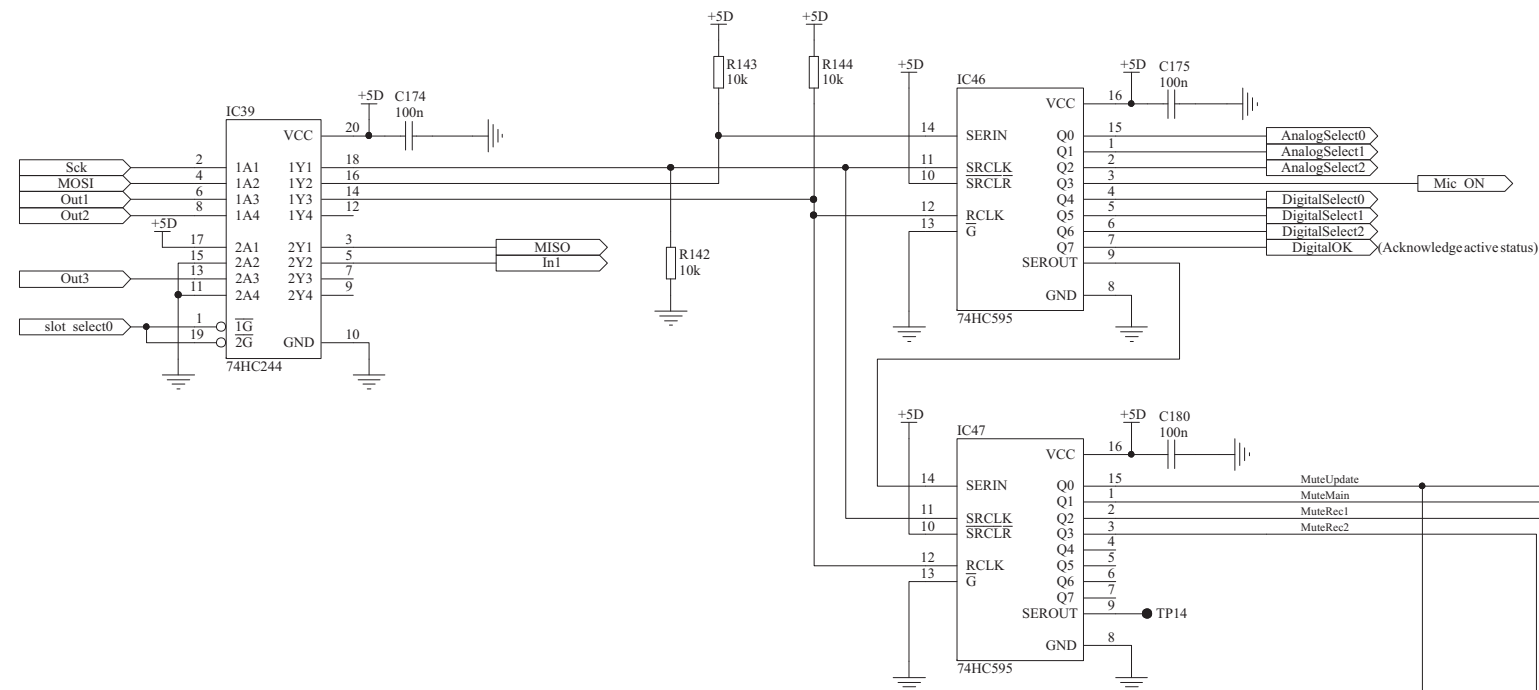

Mute controls

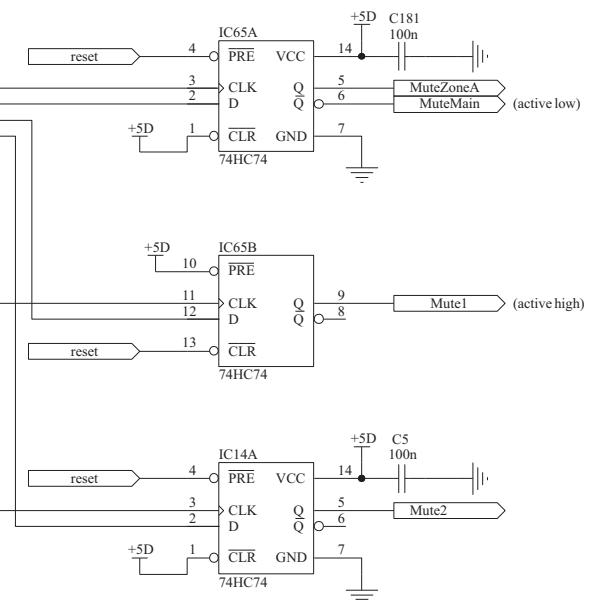

Digital Audio Input Buffer

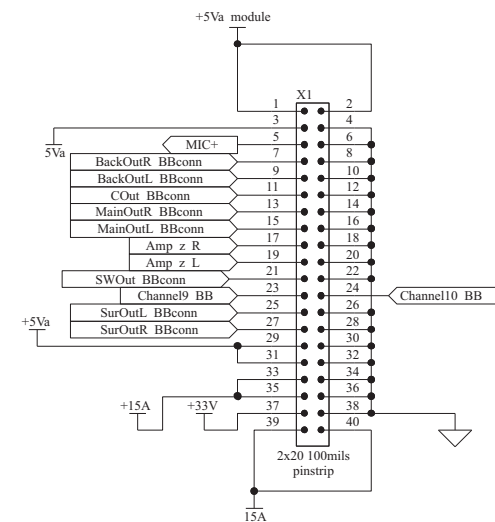
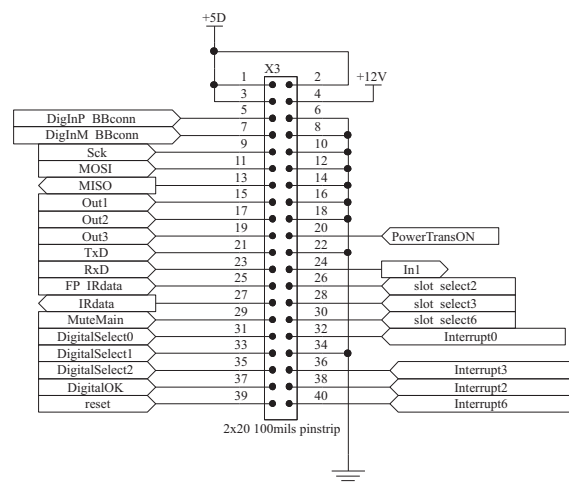
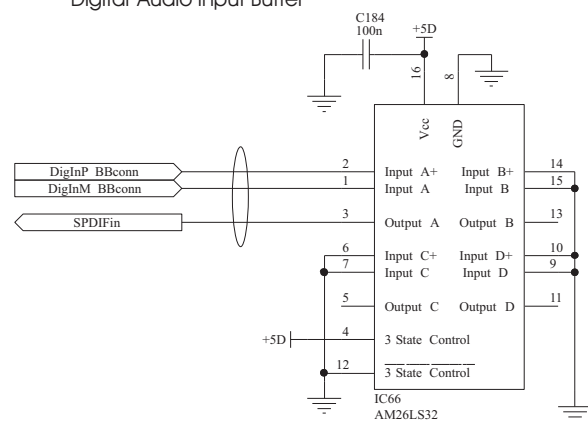

# 10 MAIN AUDIO 320165 SH 6 OF 7

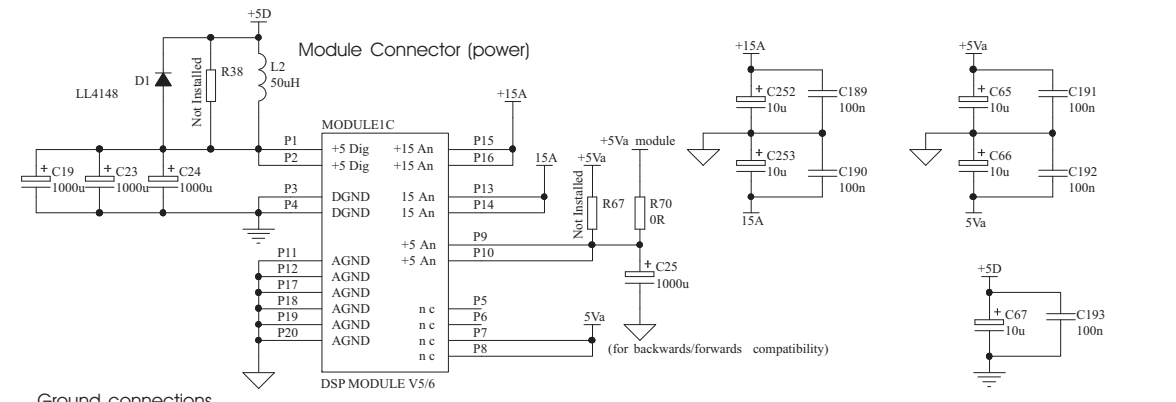

Ground connections

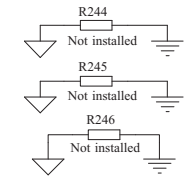

Scope Hooks etc.

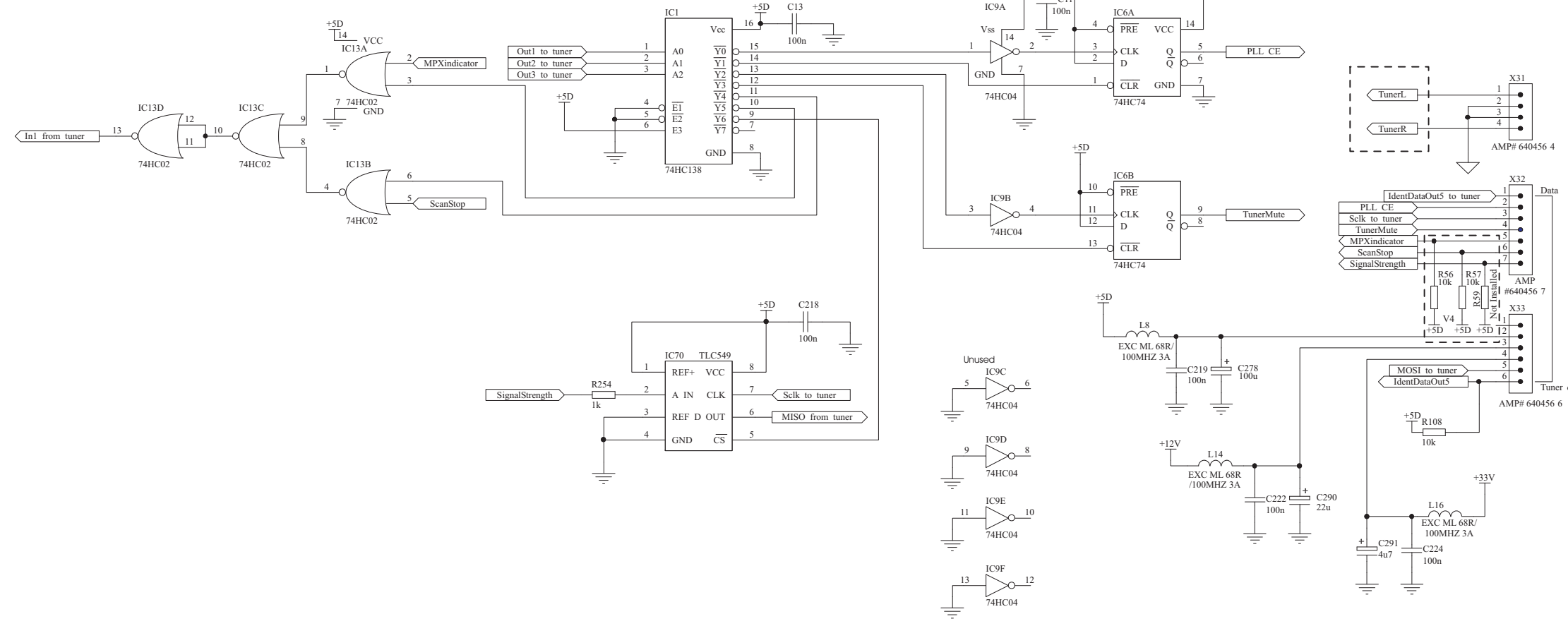
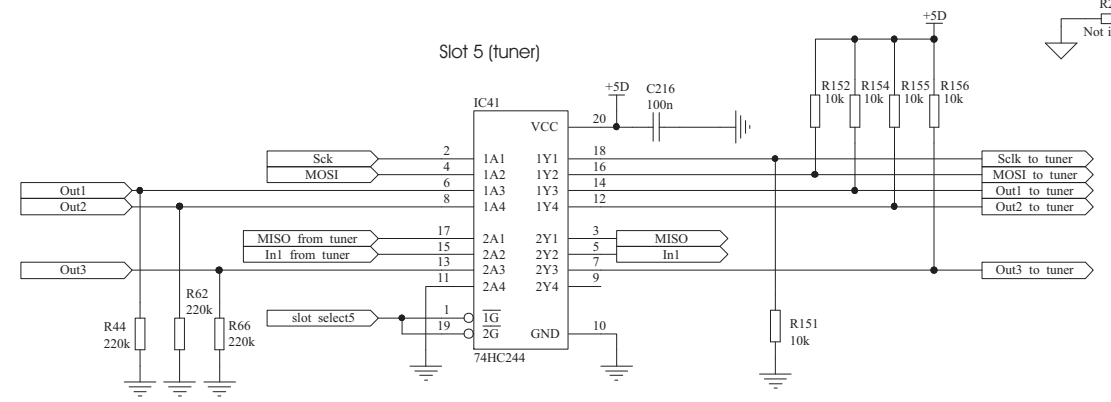
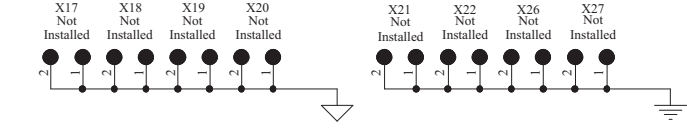

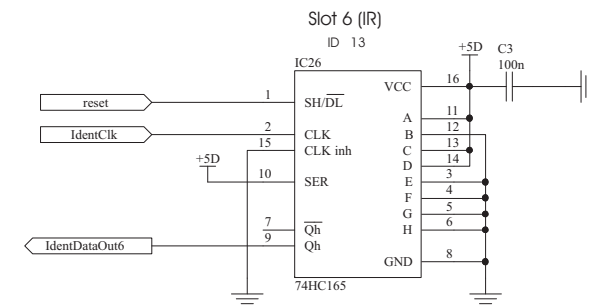
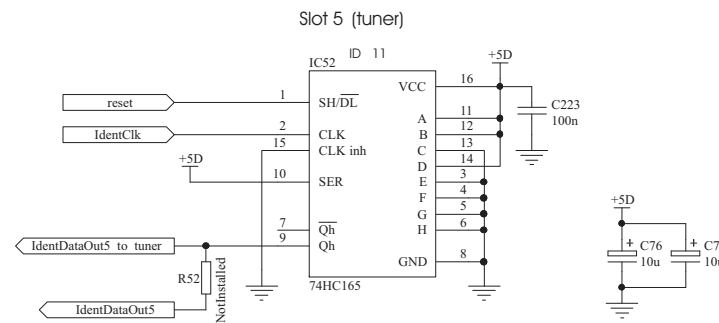
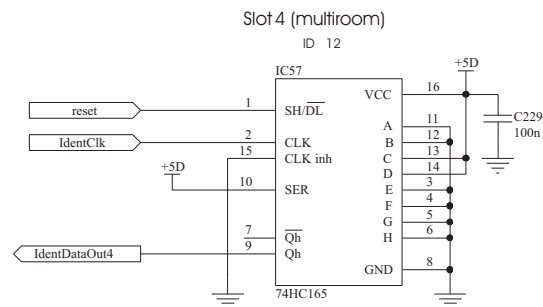
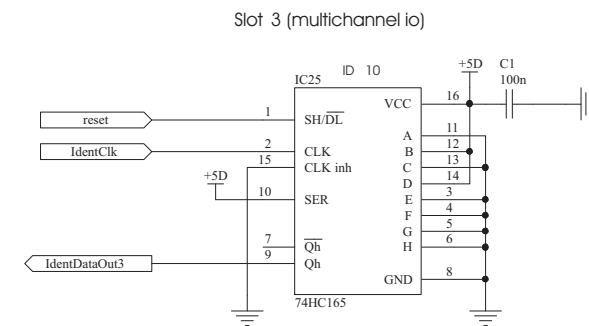
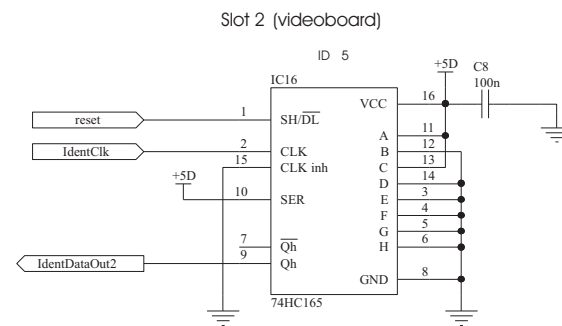
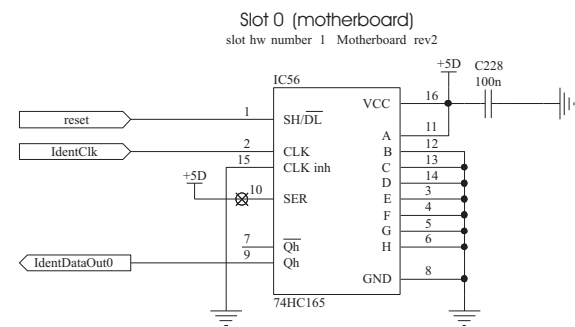

**10** MAIN AUDIO 320165

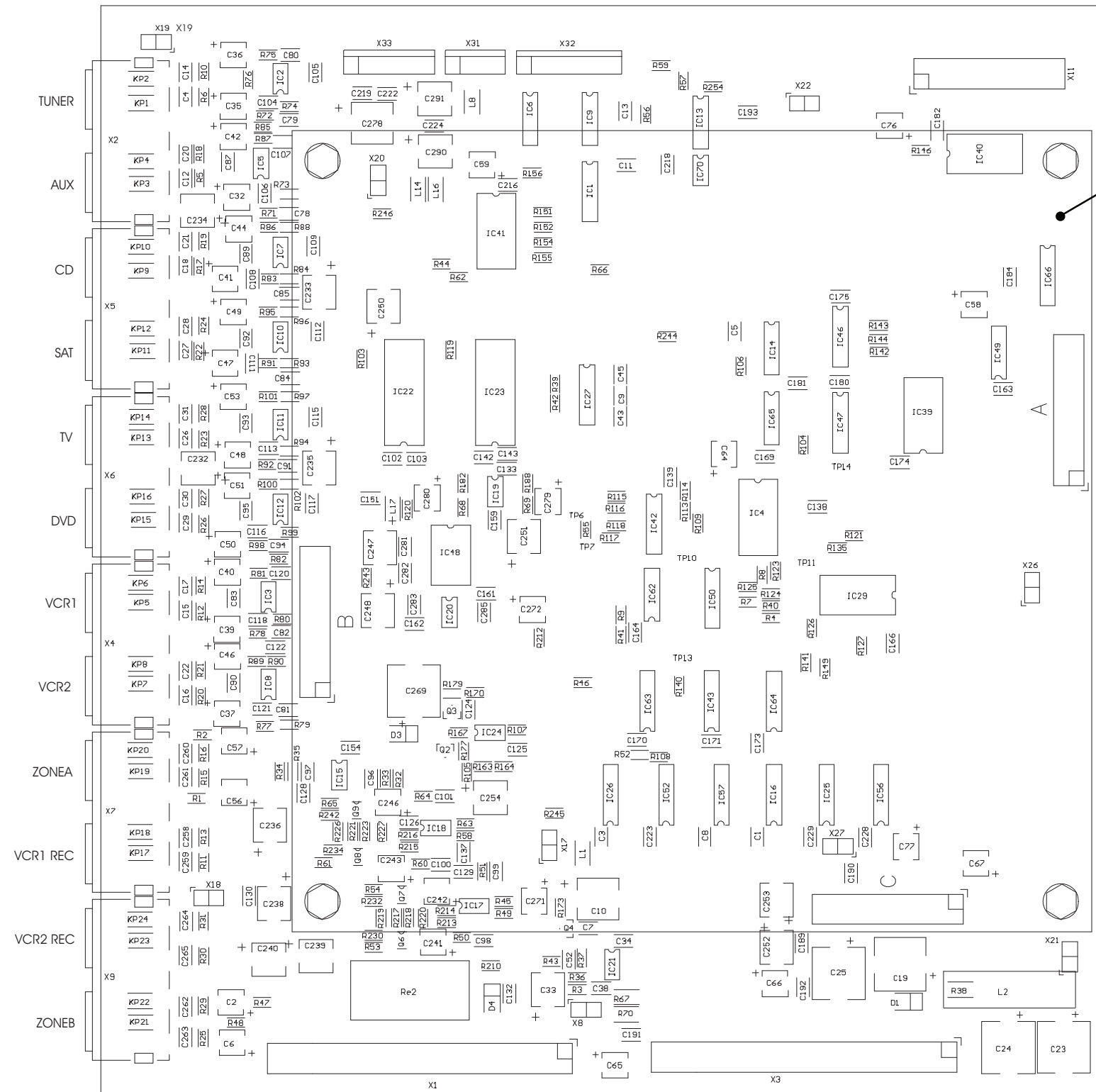

**15** DSP MODULE

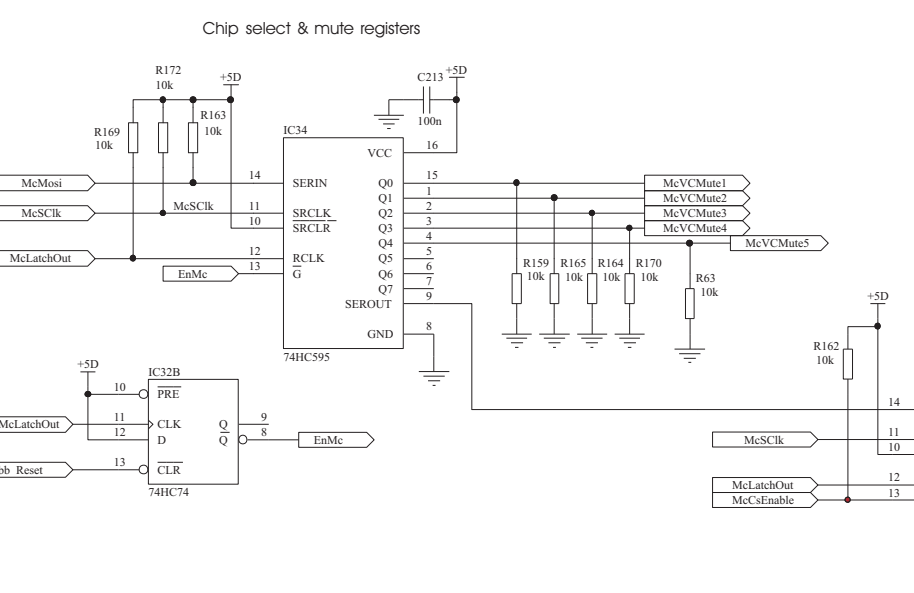
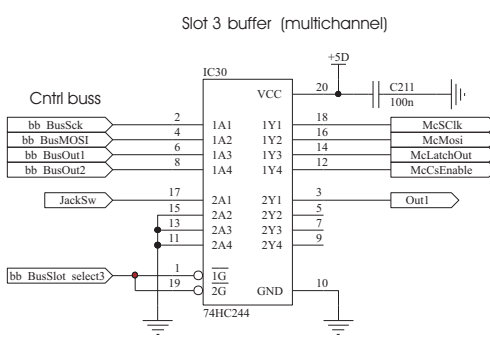
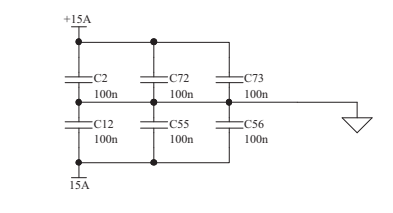
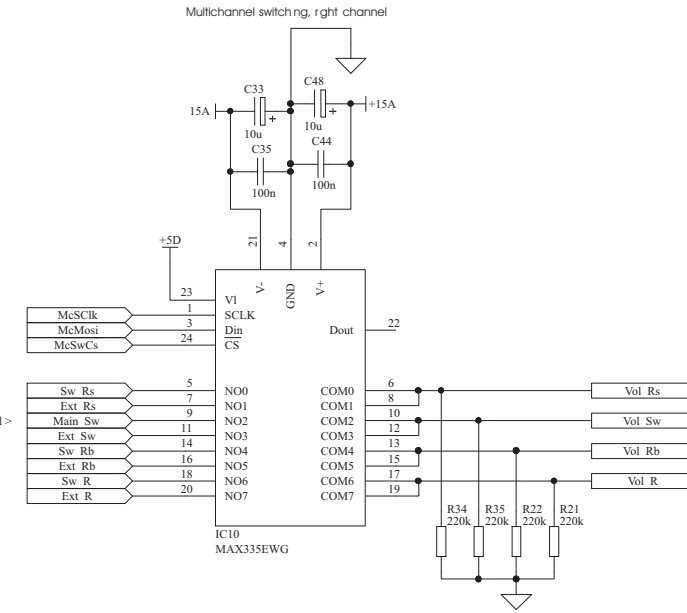
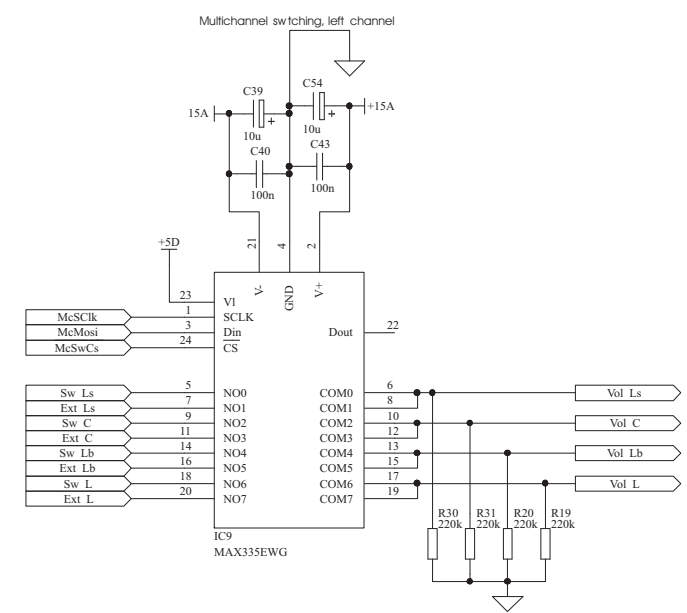
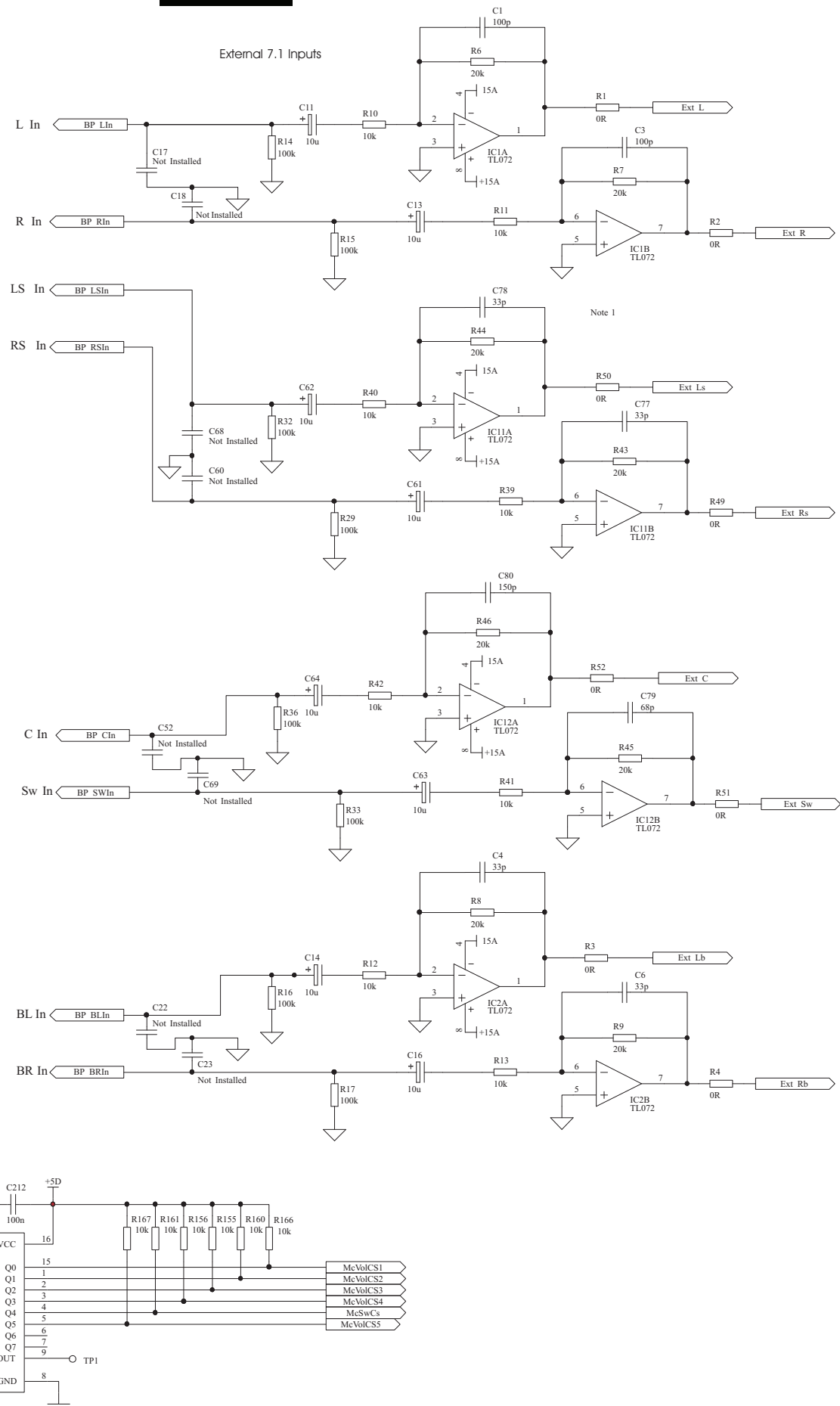

# 11 MULTI CHANNEL 320169 SH 2 OF 6

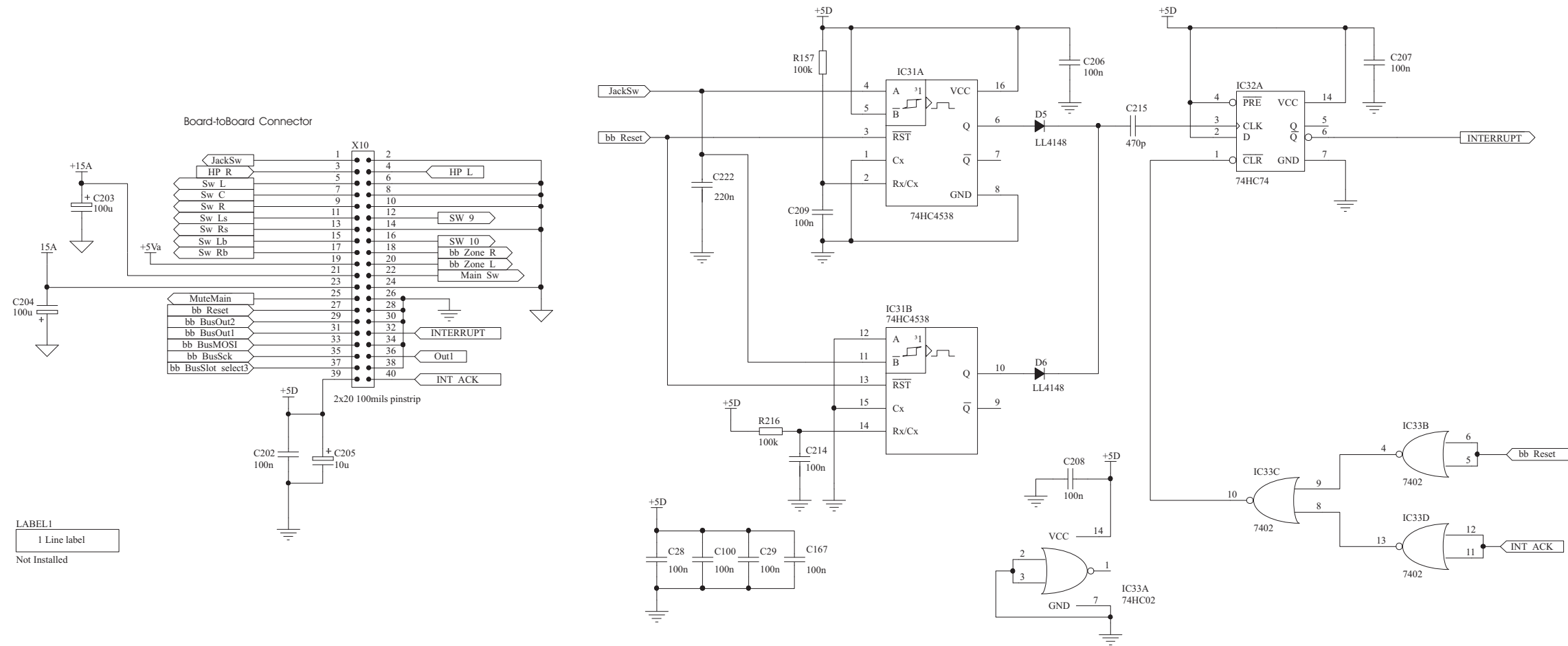

LABEL1  
1 Line label  
Not Installed



# 11 MULTI CHANNEL 320169 SH 3 OF 6

MHT200

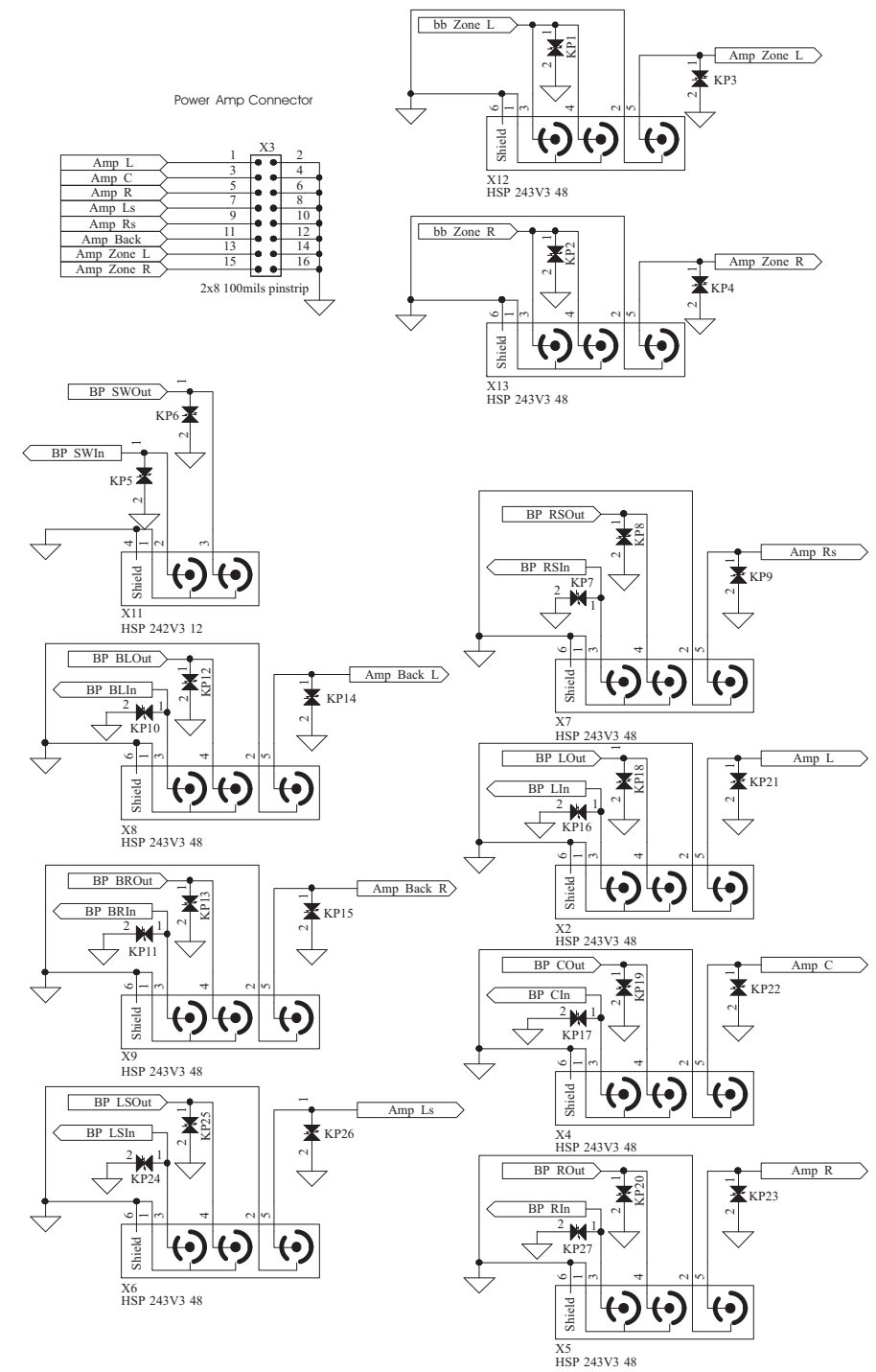
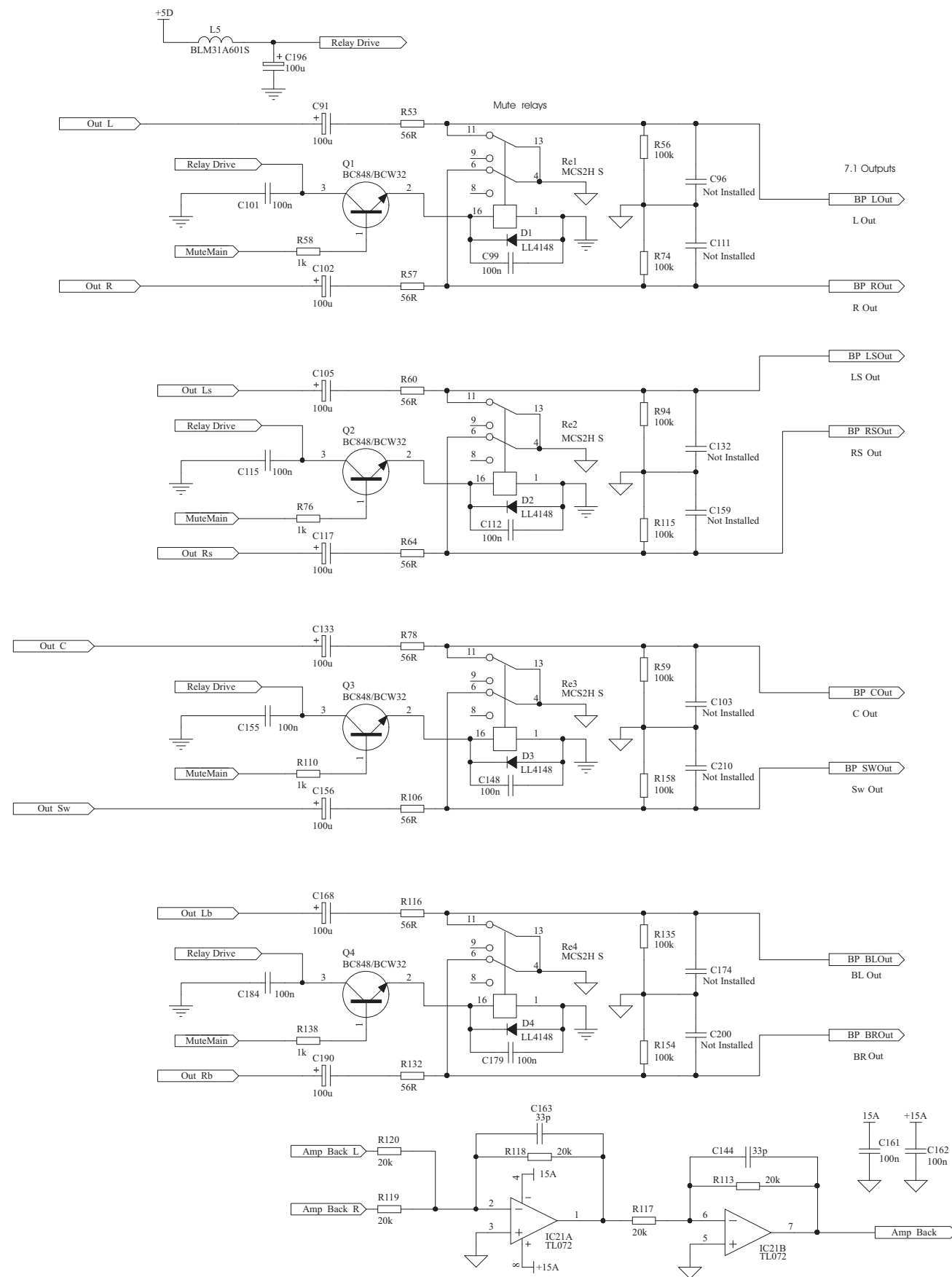

# 11 MULTI CHANNEL 320169 SH 4 OF 6

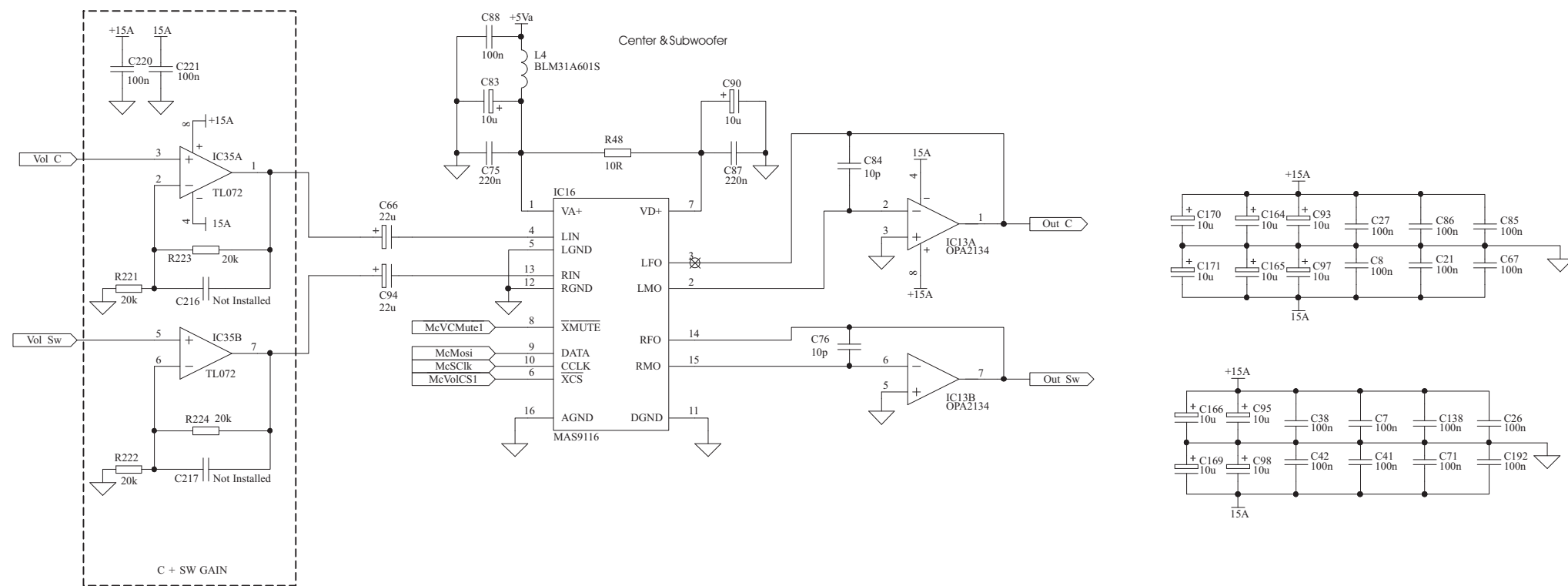
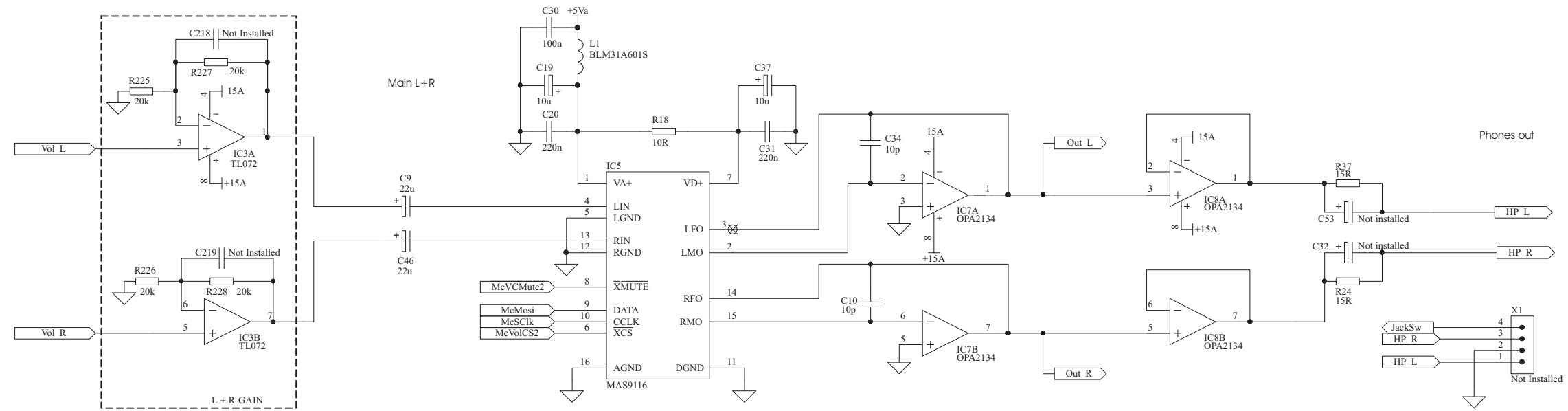

**11** MULTI CHANNEL 320169 SH 5 OF 6

MHT200

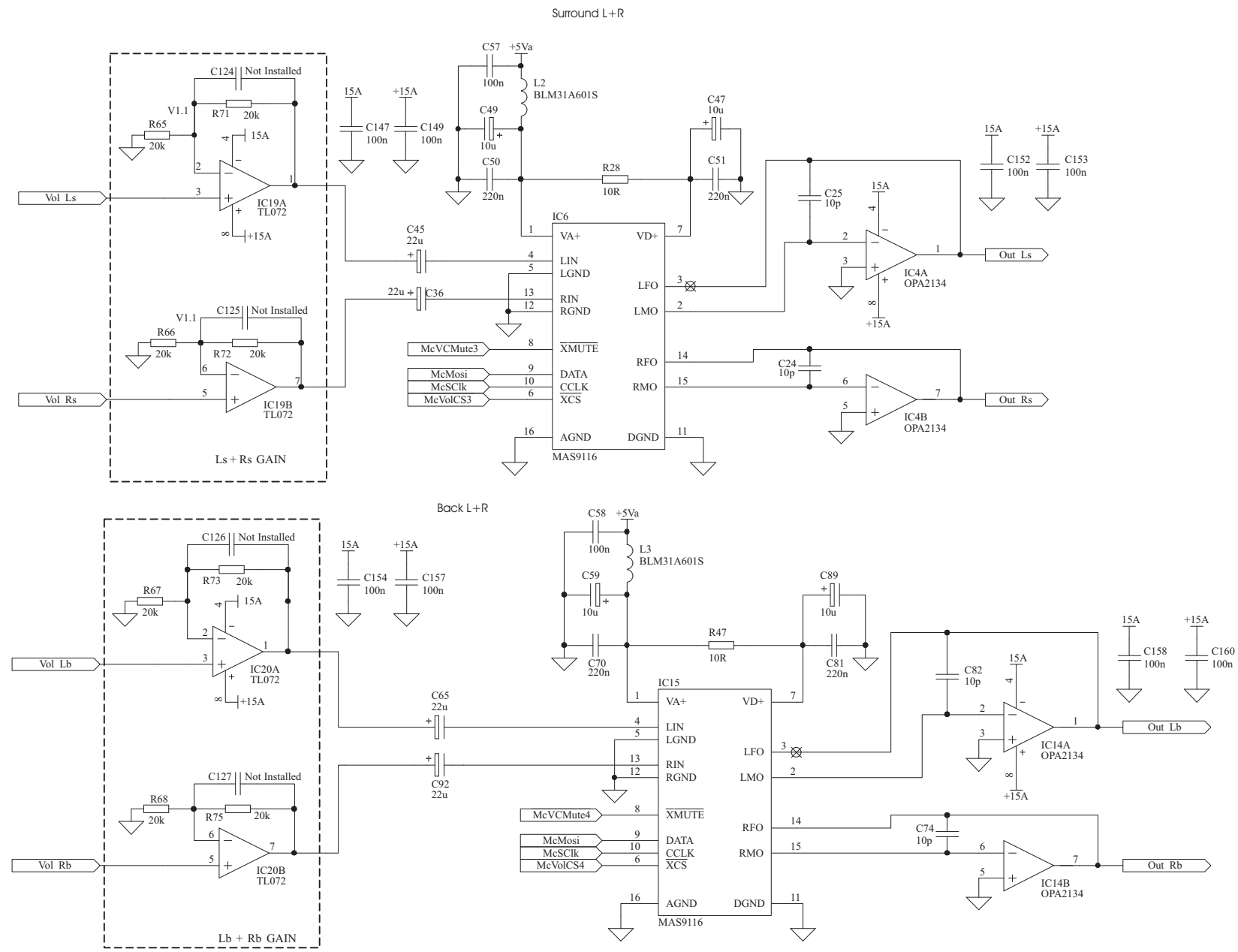

**11** MULTI CHANNEL 320169

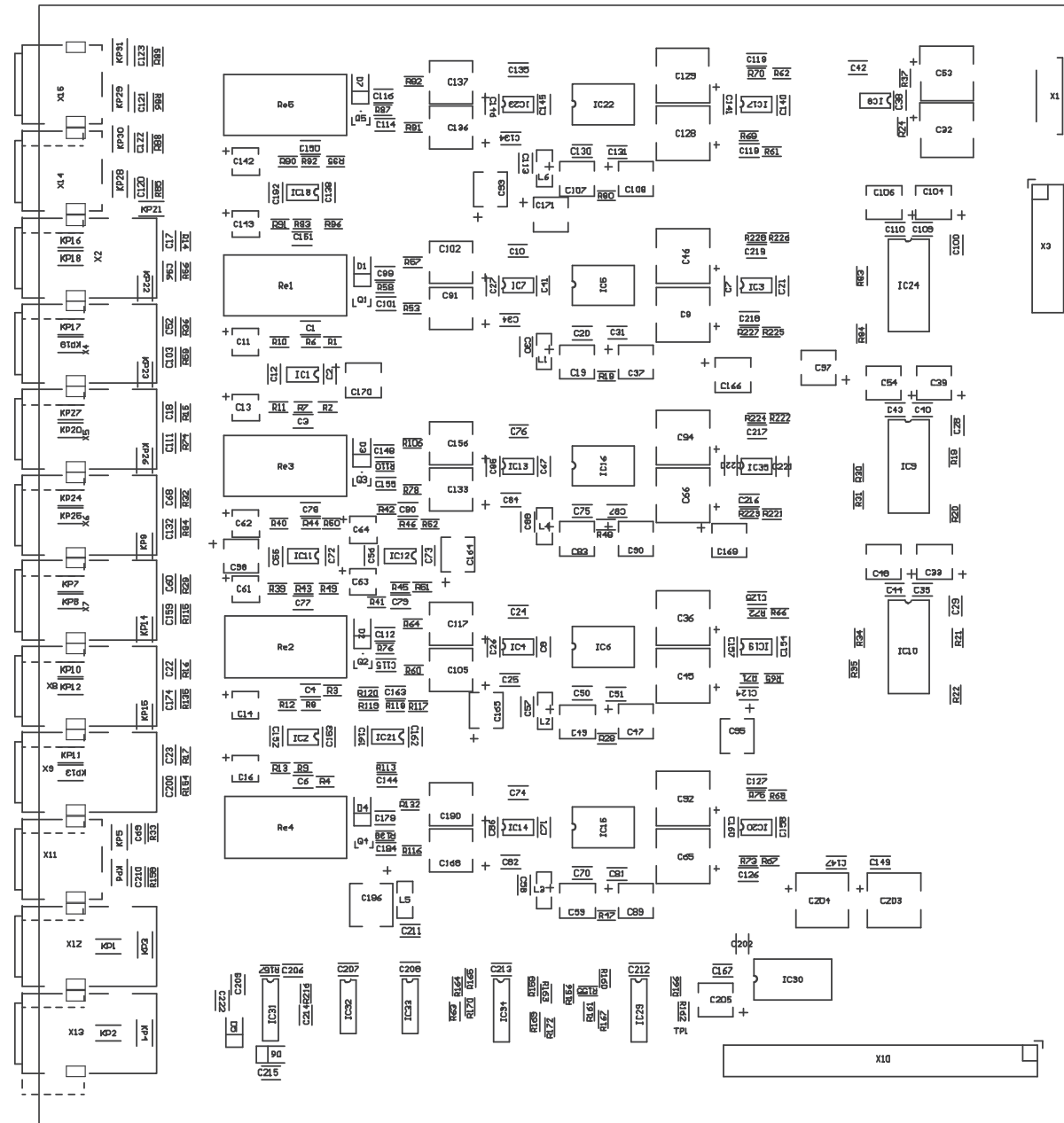

# NOTES

MHT200

# AMPLIFIER 320129 (FRONT & BACK) SH 1 OF 7

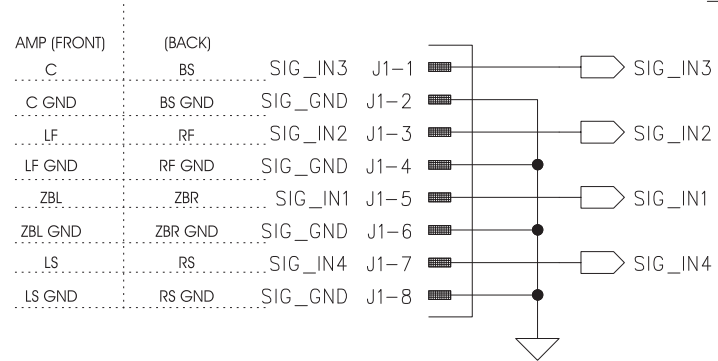
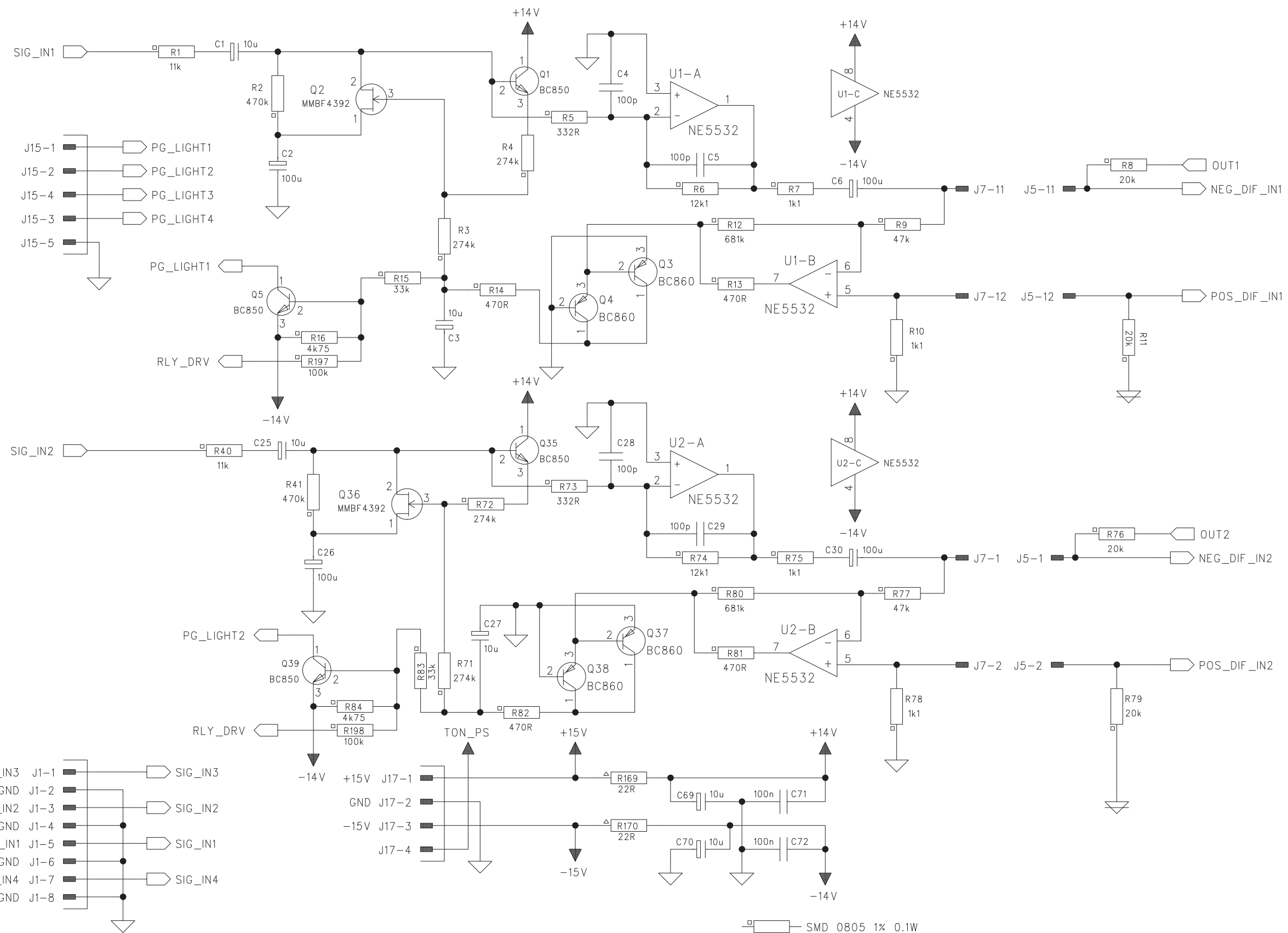

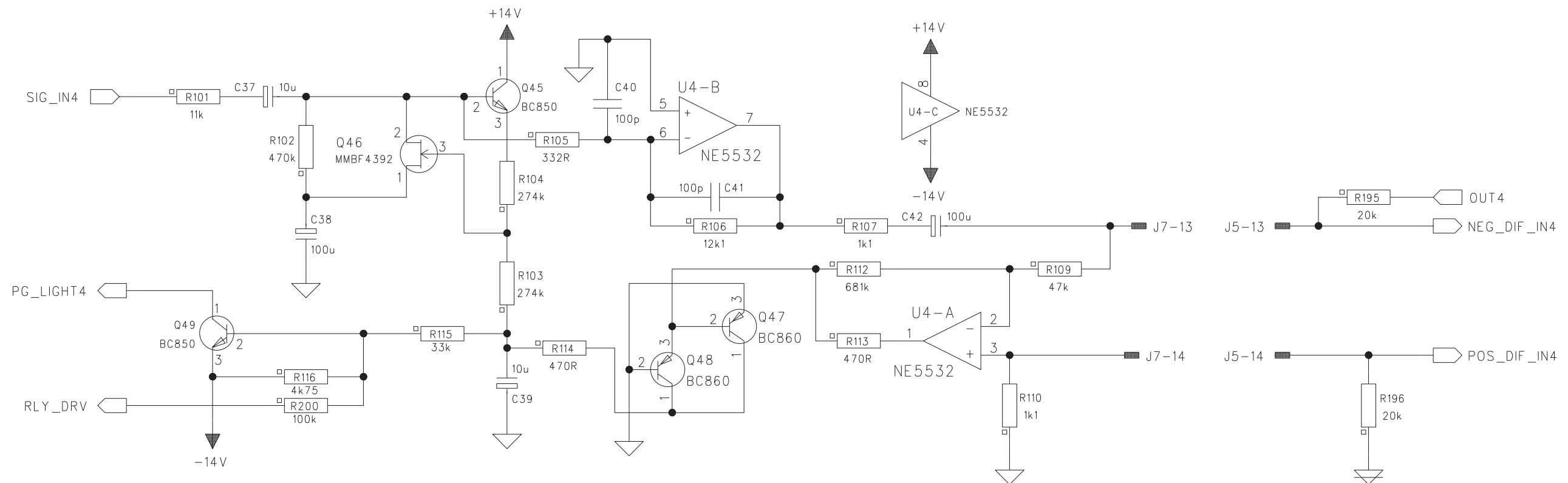
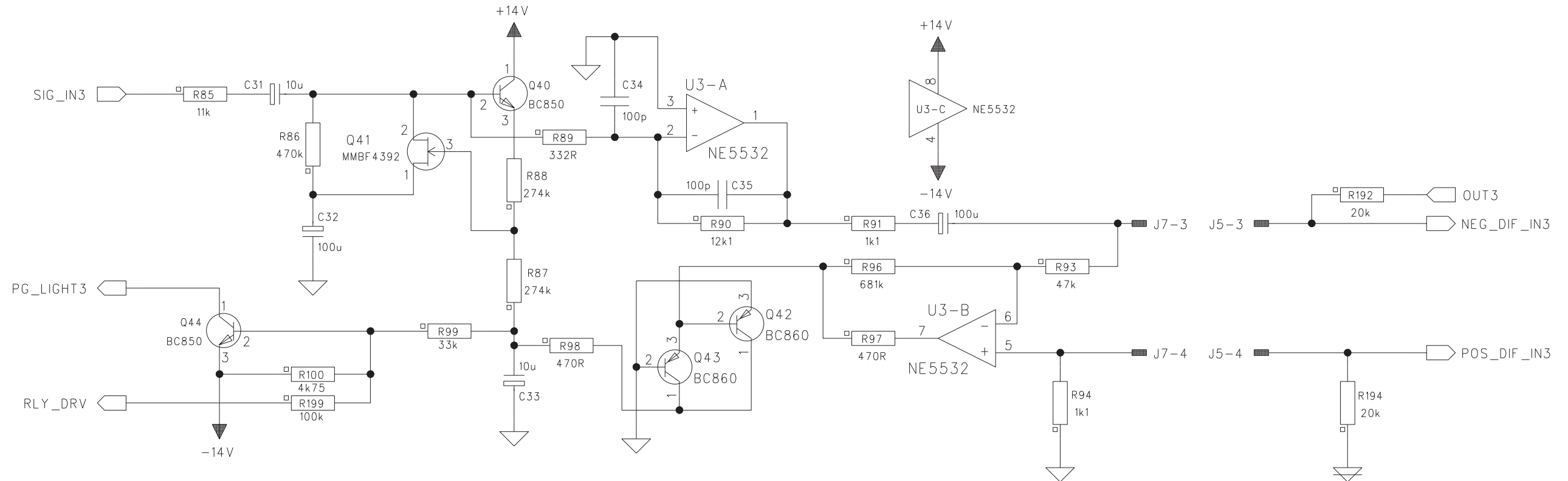

100 W Amplifier (1)

□ SMD 0805 1% 0.1W

△ PTH MFR 5% 0.6W

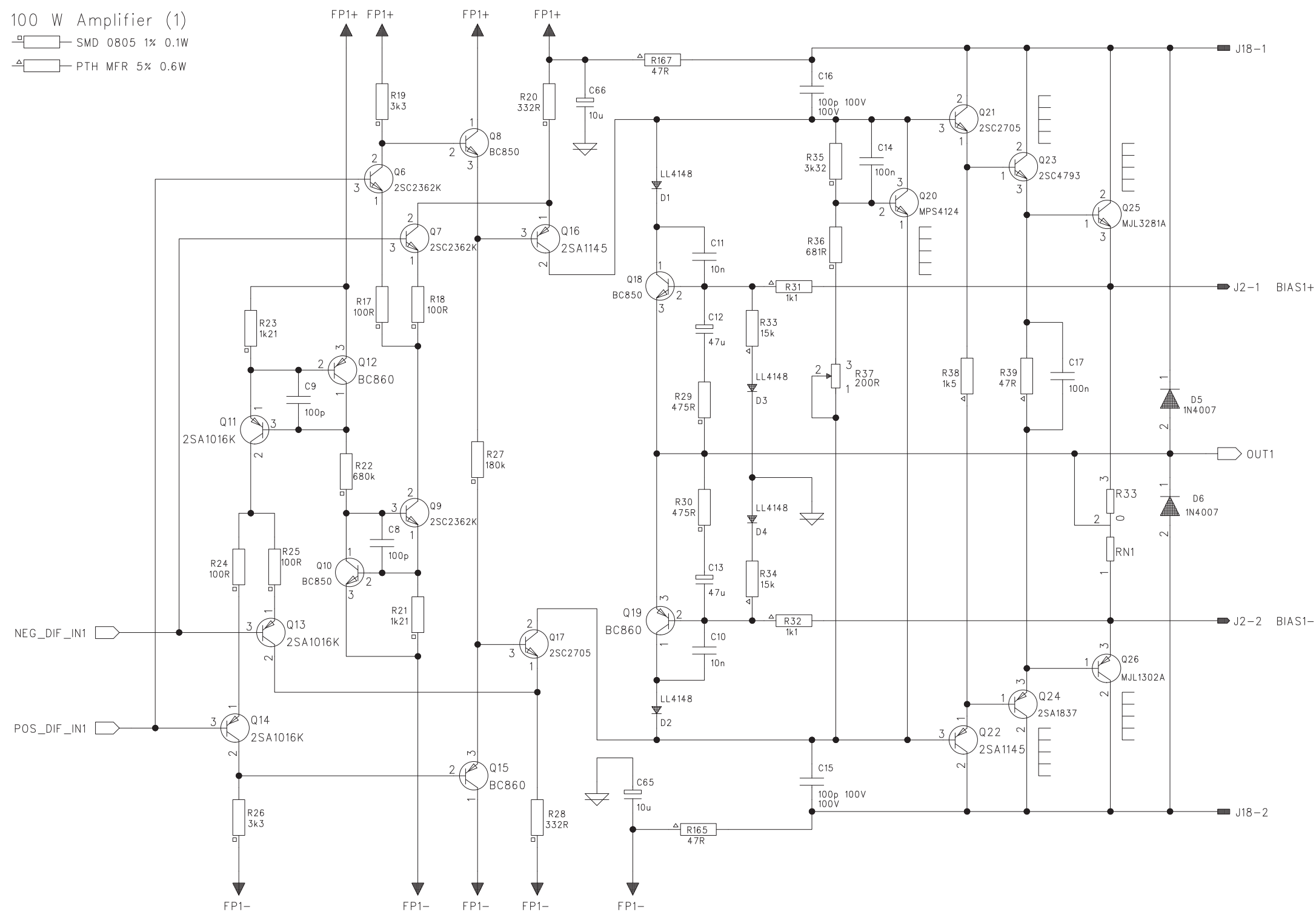



100 W Amplifier (2)

□ SMD 0805 1% 0.1W

△ PTH MFR 5% 0.6W

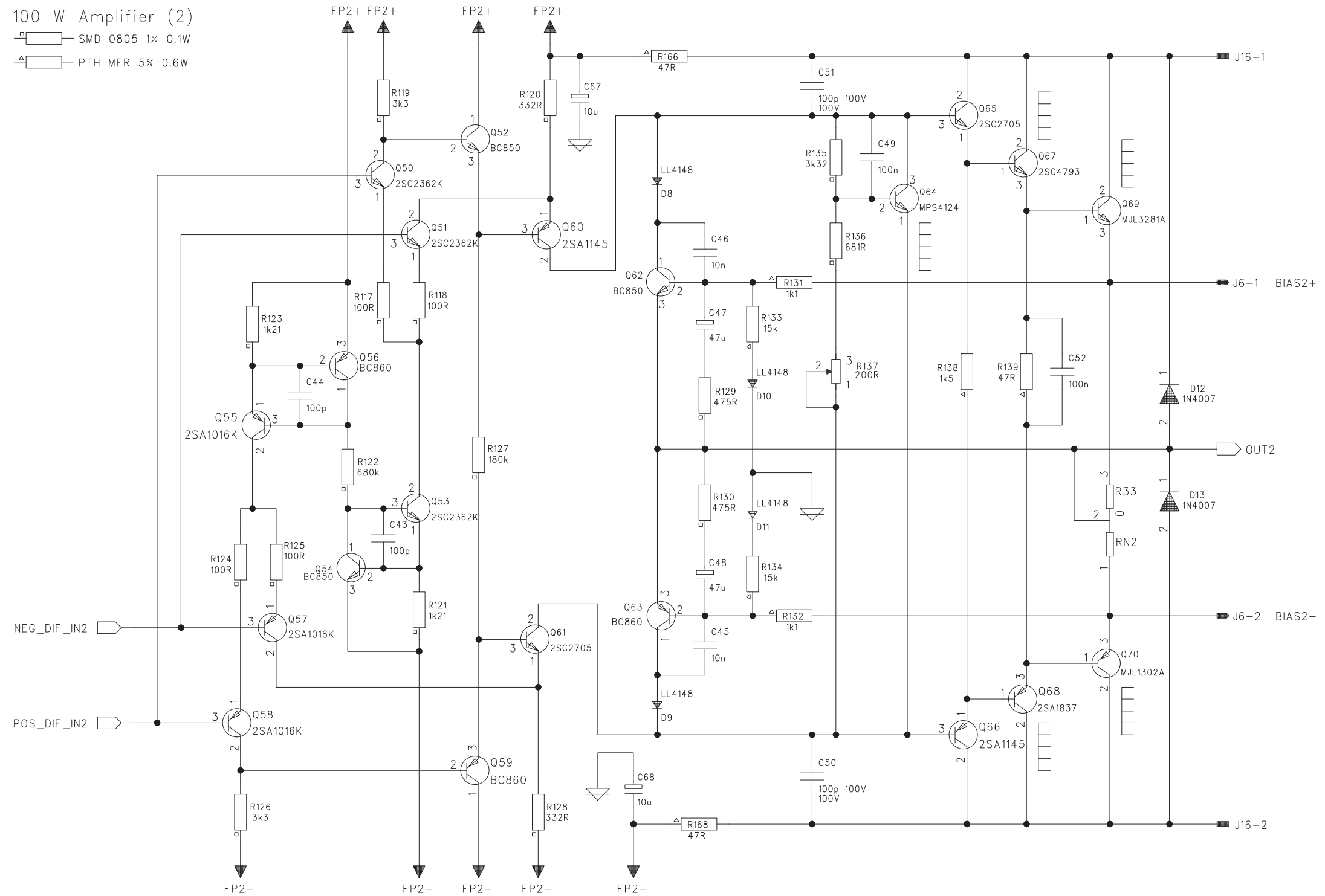

100 W Amplifier (3)

- SMD 0805 1% 0.1W
- △ PTH MFR 5% 0.6W

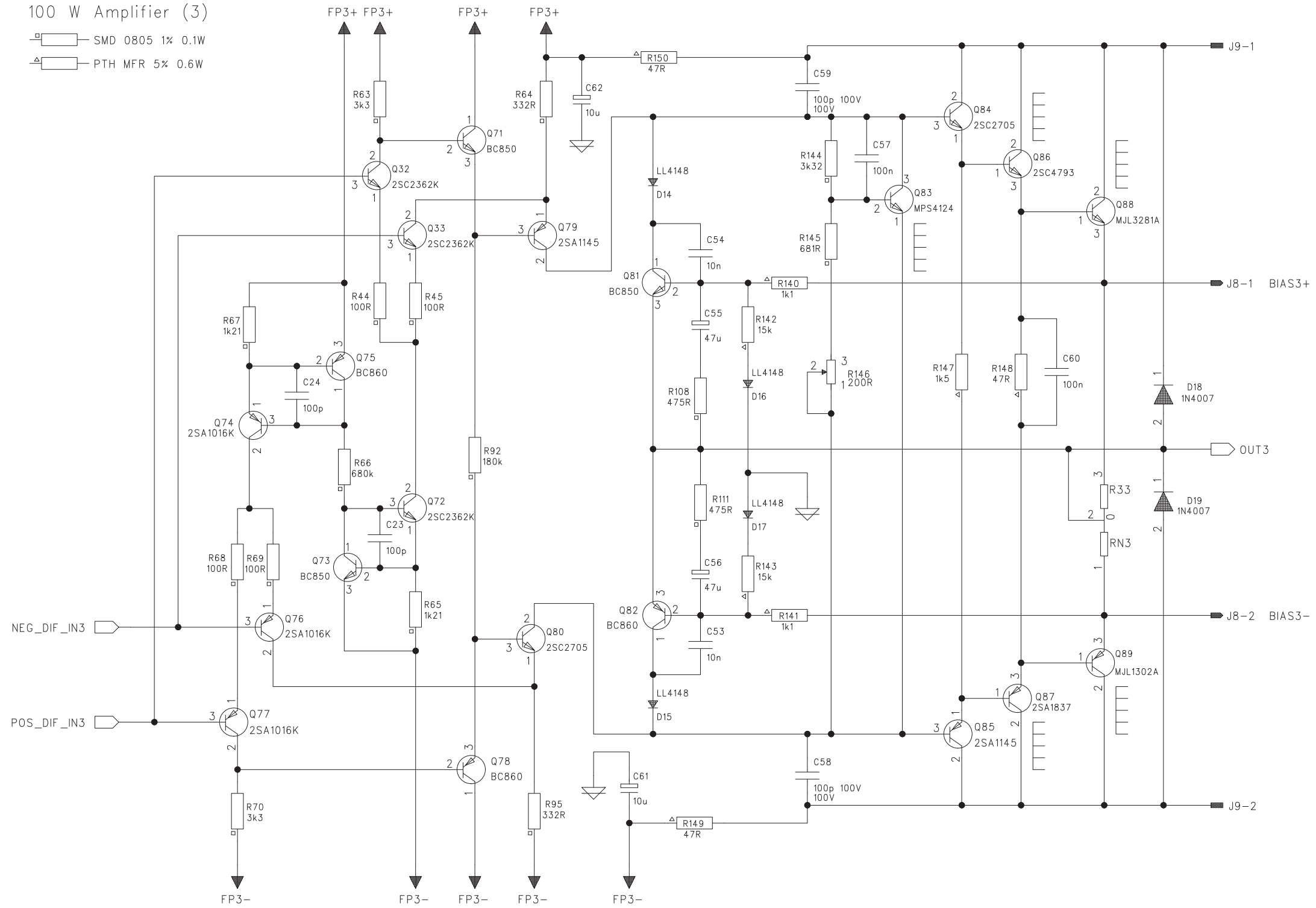

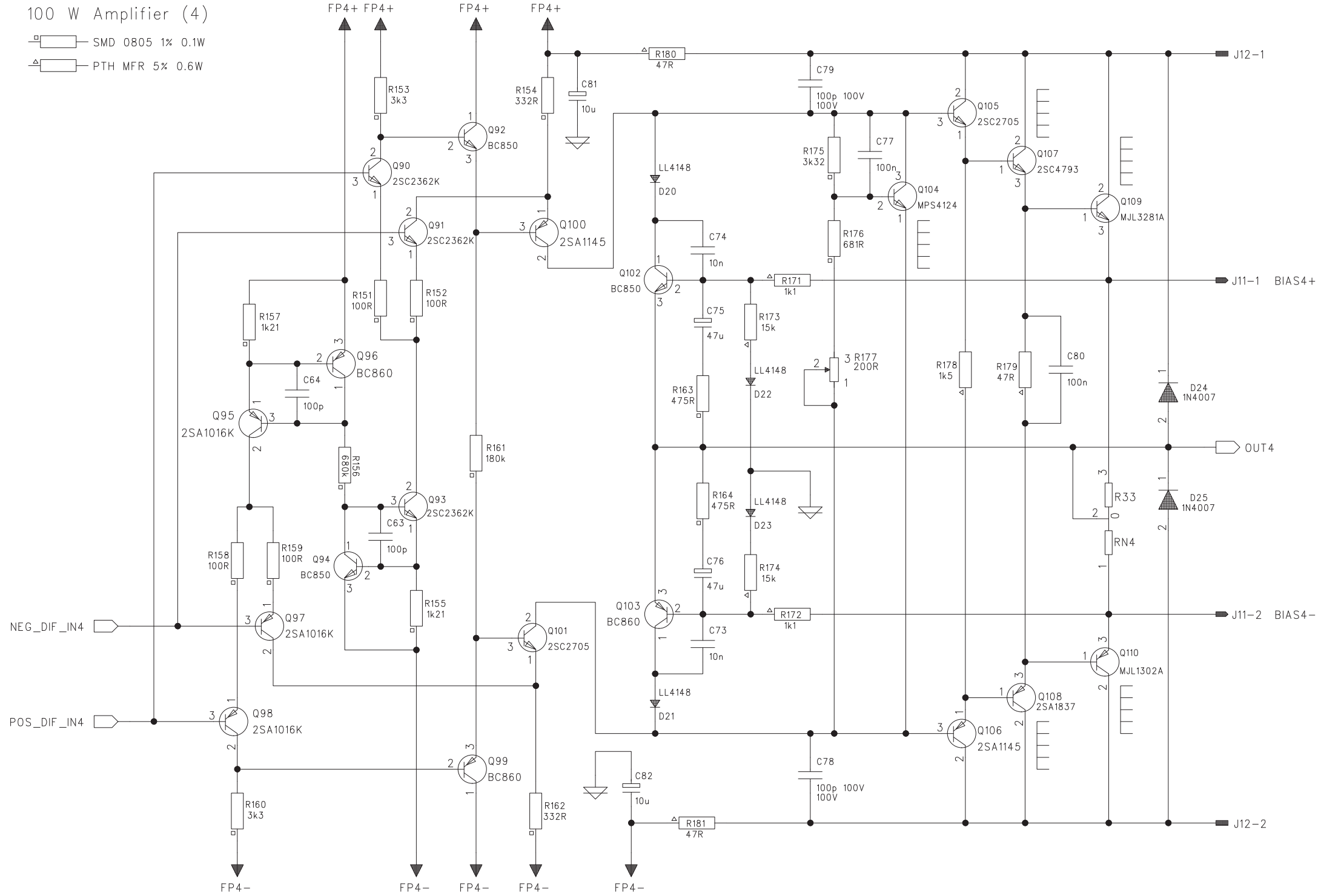

# AMPLIFIER 320129 (FRONT & BACK) SH 7 OF 7

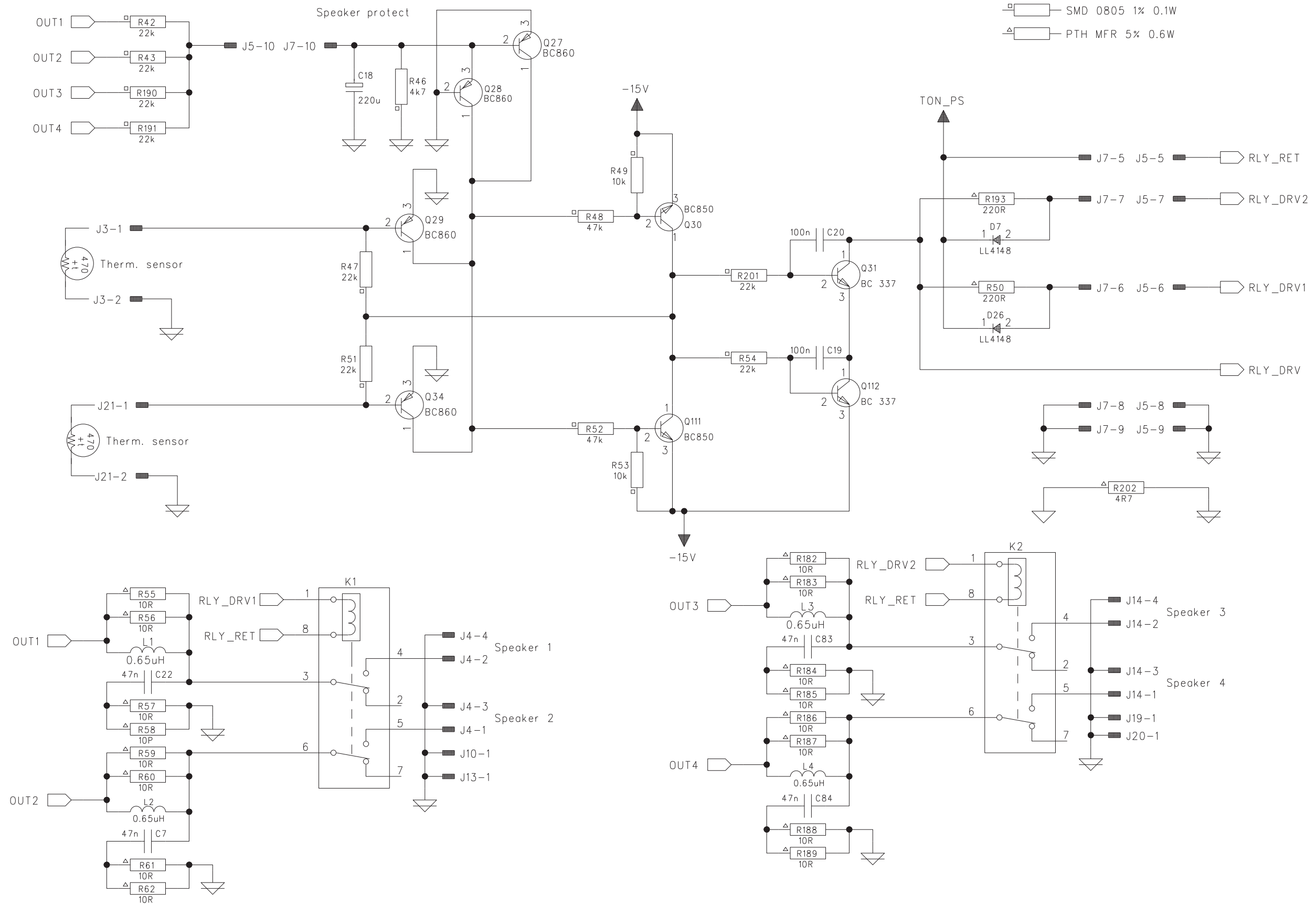

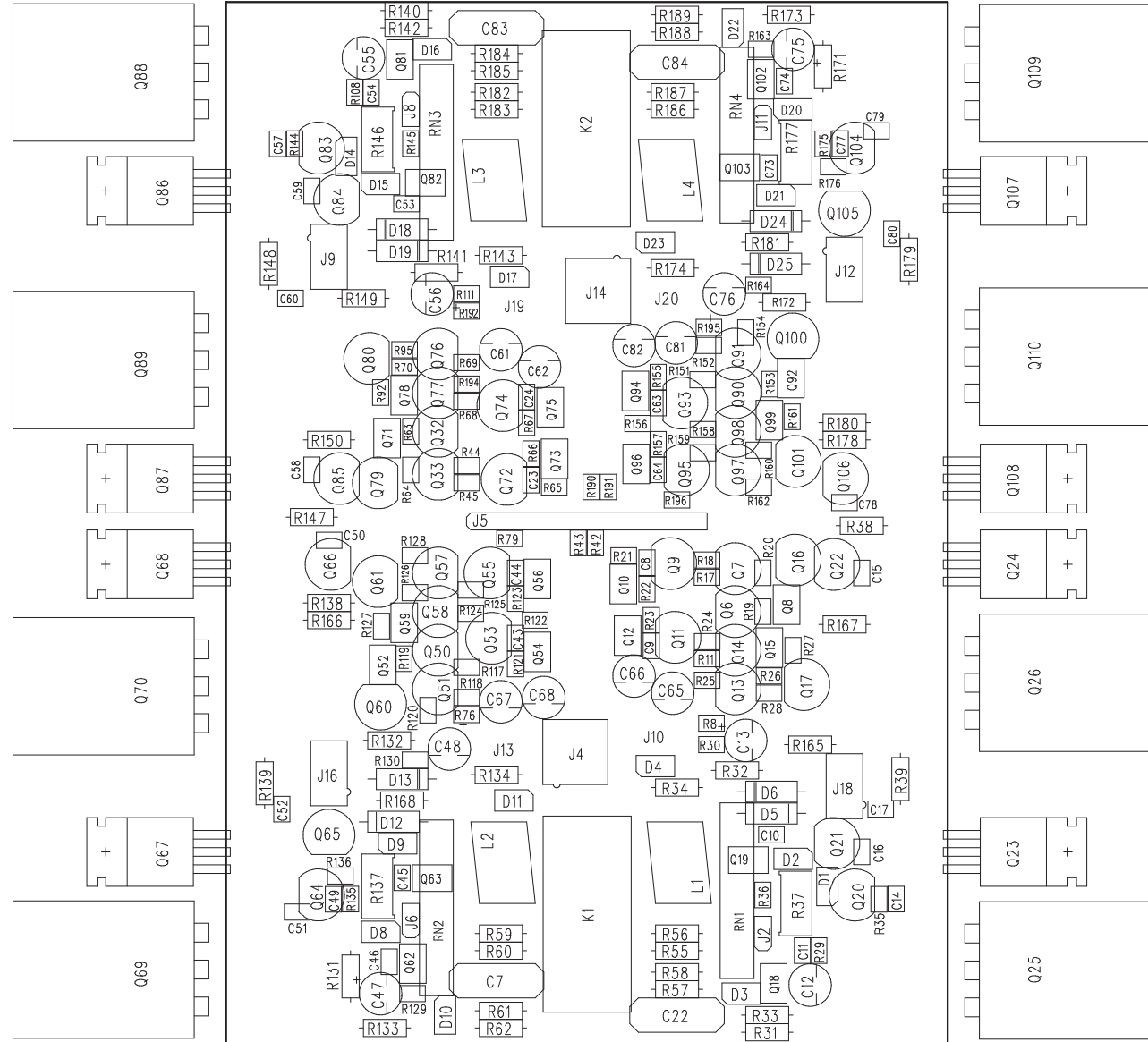
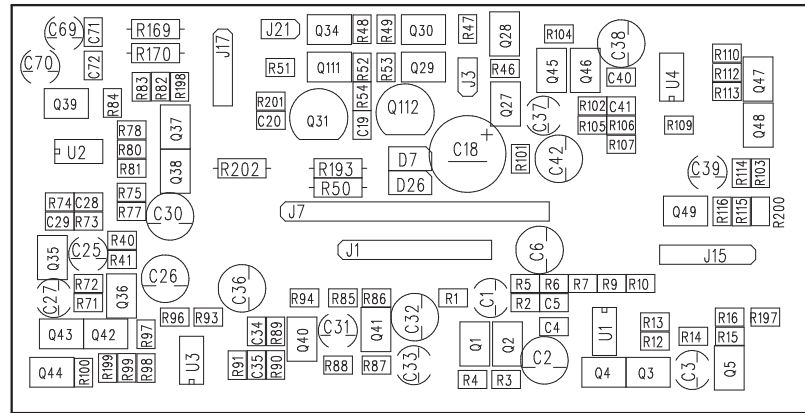

# TUNER ALIGNMENT PROCEDURE

Note: Refer to Figure 1 while reading the below procedure.

## FM ALIGNMENT PROCEDURE

1. Connect an FM Signal Generator to Antenna Input.
2. Connect Distortion Analyzer to the TUNER INPUT RCA jacks. (These jacks act as the Tuner Output.)
3. Remove Top Cover and AM/FM TUNER Cover. Turn On the AC rocker switch. Press the red Standby button to turn the unit On.
4. Select Tuner with the Zone A selector knob. Put Tuner into FM mode and tune to 87.5MHz.
5. Adjust L5 (FM OSC Coil) for 3.5VDC at R46.
6. Tune to 108.5MHz and adjust C59 (FM OSC Trimmer Capacitor) for 24.5VDC at R46.
7. Repeat steps 4, 5 and 6 as necessary for a tuning range of 3.5VDC to 24.5VDC at R46.
8. Tune the Generator and Tuner to 90MHz and adjust Coils: L2 (FM MIX), L3 (FM RF) and L4 (FM ANT) for best sensitivity.
9. Tune the Generator and Tuner to 104MHz and adjust Trimmer Capacitors: C60 (FM MIX), C62 (FM RF) and C63 (FM ANT) for best sensitivity.
10. Repeat 8 and 9 until no improvement in sensitivity is noted.
11. Tune Tuner to 90MHz with no RF Input and adjust T9 (FM DETector Primary) for zero volts between TP1 and TP2 relative (connector J6).
12. Tune the Generator to 90MHz and adjust the RF Output to 1000uV and 100% MONO modulation at 1000Hz. Then adjust T8 (FM DETector SECondary) for lowest distortion.
13. Reduce the Generator Output to minimum and detune the Generator so the Receiver picks up only noise, then recheck the voltage between TP1 and TP2 (connector J6). Adjust T8 and C65 if needed. If it is not 0+/- 0.2VDC, repeat steps 11 and 12. If there is interference from a station on this frequency, tune the Tuner to a nearby frequency free from interference for this measurement.
14. Tune the Generator to 90MHz with a 1000uV output. Then switch the Generator to stereo (left only) and adjust T10 (FM IF Transformer) for the lowest distortion at the TUNER INPUT RCA jacks.
15. Switch the Analyzer to the right channel TUNER INPUT jack and adjust R71 (MPX SEPARation Pot) for best separation (minimum output).
16. Switch the Generator to the Right Channel and the Analyzer to the Left Channel. Adjust R71 (MPX SEPARation Pot) and check for best separation (minimum output).
17. Disconnect voltmeter from TP1 and TP2 (J6). Reduce the generator output to 5uV and adjust R73 (STEREO SWITCH Pot) so the MPX light (Dot next to Signal Strength number) just comes on.

## AM ALIGNMENT PROCEDURE

1. Connect an AM Signal Generator to the RAA1 "EXT ANT" pin of the 5 pin connector. (Refer to Page 110.) Connect a Distortion Analyzer to the MHT200 rear panel TUNER INPUT RCA jacks. (These jacks act as the Tuner Output.)
2. Tune to bottom of band, and adjust T11 (AM OSC Coil) for 3.0VDC at R46.
3. Tune to top of band and adjust C64 (AM OSC Trimmer Capacitor) for 26.0VDC at Connector R46.
4. Repeat steps 4 and 5 as necessary for a Tuning Voltage Range of 3.0 to 26.0VDC.
5. Tune the Generator and Tuner to 600kHz, then adjust Coils: T101 (AM ANT) and T12 (AM RF) for best sensitivity. Note: Coil T101 (AM ANT) is located on the RAA1. It is labeled "L1".

6. Tune the Generator and Tuner to 1400kHz, then adjust Trimmer Capacitors: C106 (AM ANT) and C61 (AM RF) for best sensitivity. Note: Trimmer Capacitor C106 (AM AMT) is located on the RAA1. It is labeled "C1".
7. Repeat 8 and 9 until no improvement in sensitivity is noted.
8. Note the initial position of R70, and then adjust R70 fully counter clockwise. Tune the Generator and Tuner to 1400kHz (20uV, 30% modulation), then Adjust T7 (AM IF) for maximum signal.
9. Tune the Generator and Tuner to 1400kHz (100mV, 30% modulation). Slowly adjust R70 clockwise until the MHT100 front panel signal strength display reads "9".
10. Check both channels for signal to noise performance, and re-adjust R70 and as needed.

Figure 1

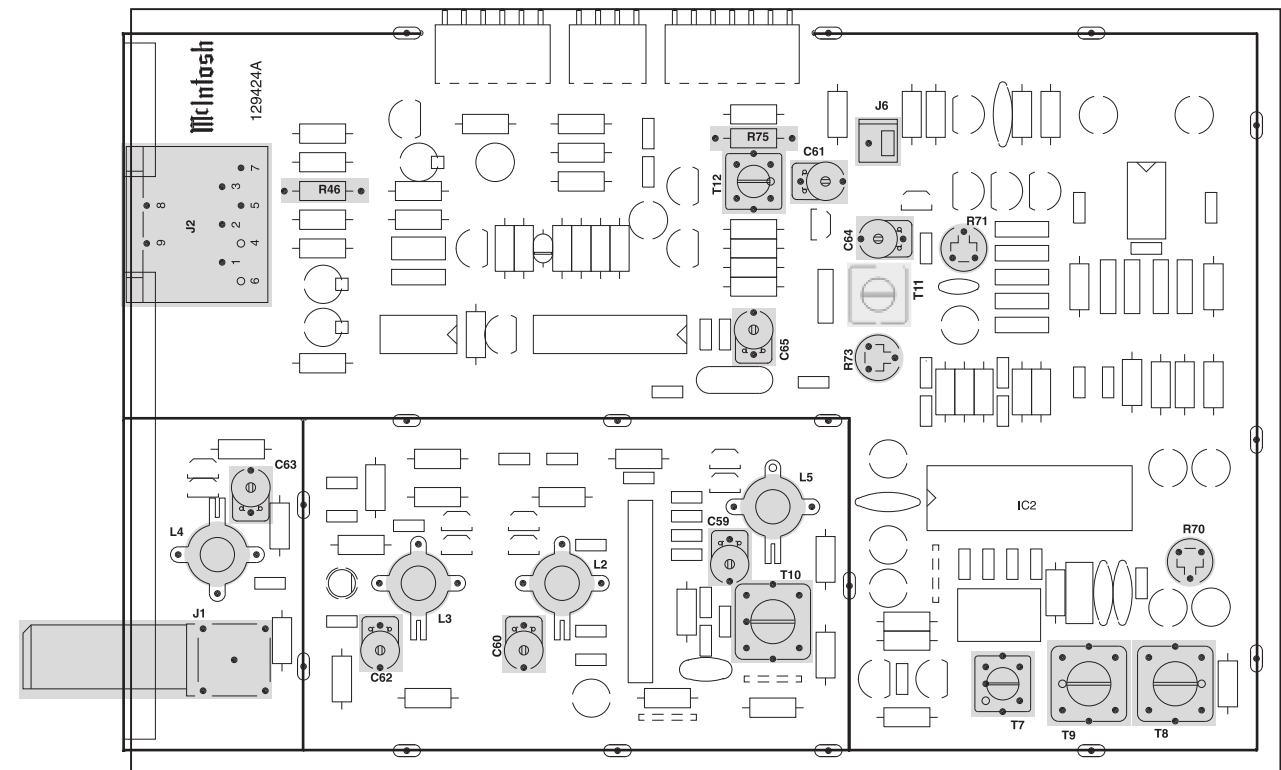

# 13 TUNER 049084

MHT200

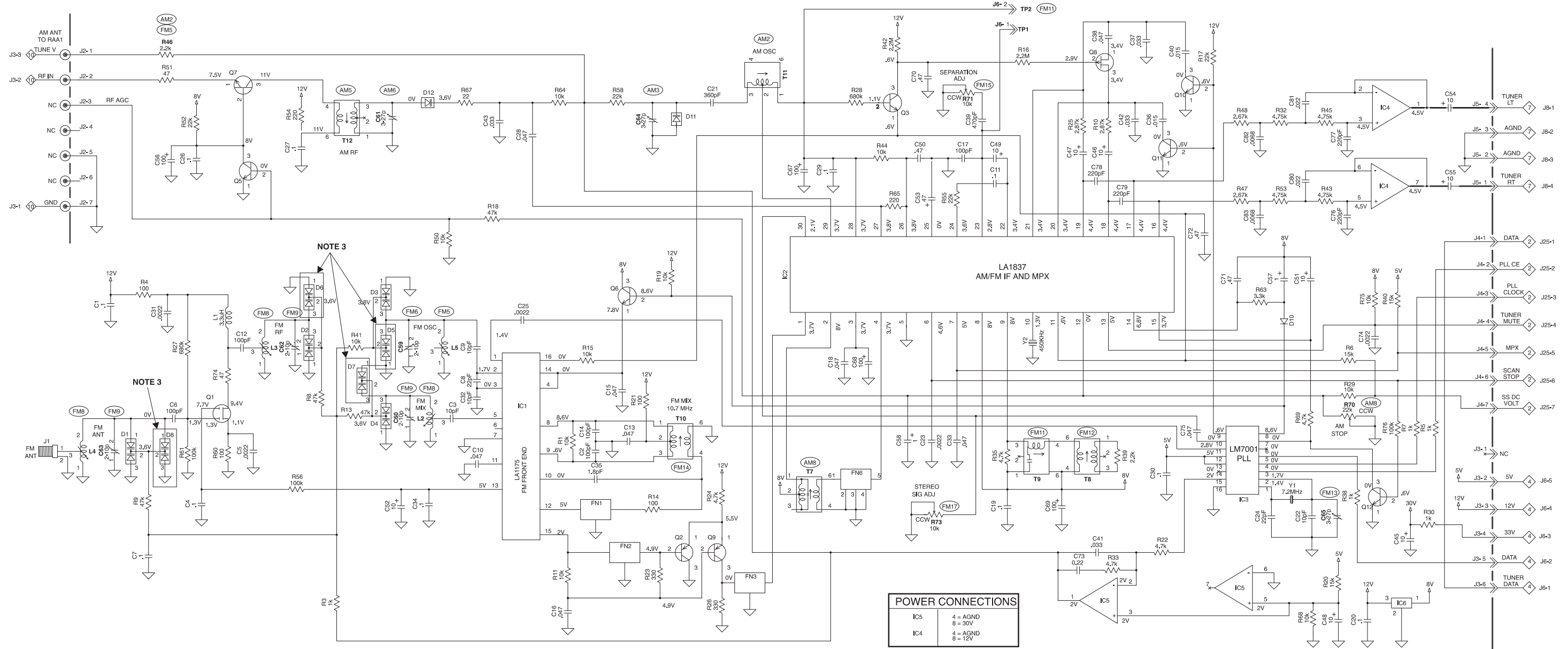

**POWER CONNECTIONS**

IC5	4 = AGND
	8 = 30V
IC4	4 = AGND
	8 = 12V

NOTES: SEE PAGE 105 - 106 FOR TUNER ALIGNMENT PROCEDURES.  
 (FM1) THROUGH (FM17) REFER TO STEPS IN THE FM ALIGNMENT PROCEDURE.  
 (AM1) THROUGH (AM10) REFER TO STEPS IN THE AM ALIGNMENT PROCEDURE.  
 NOTE 3: FOR JAPANESE CONVERSION, VARACTORS D5, D6, D7 AND D8 ARE ADDED IN PARALLEL WITH D1, D2, D3 AND D4.

# 13 TUNER 049084

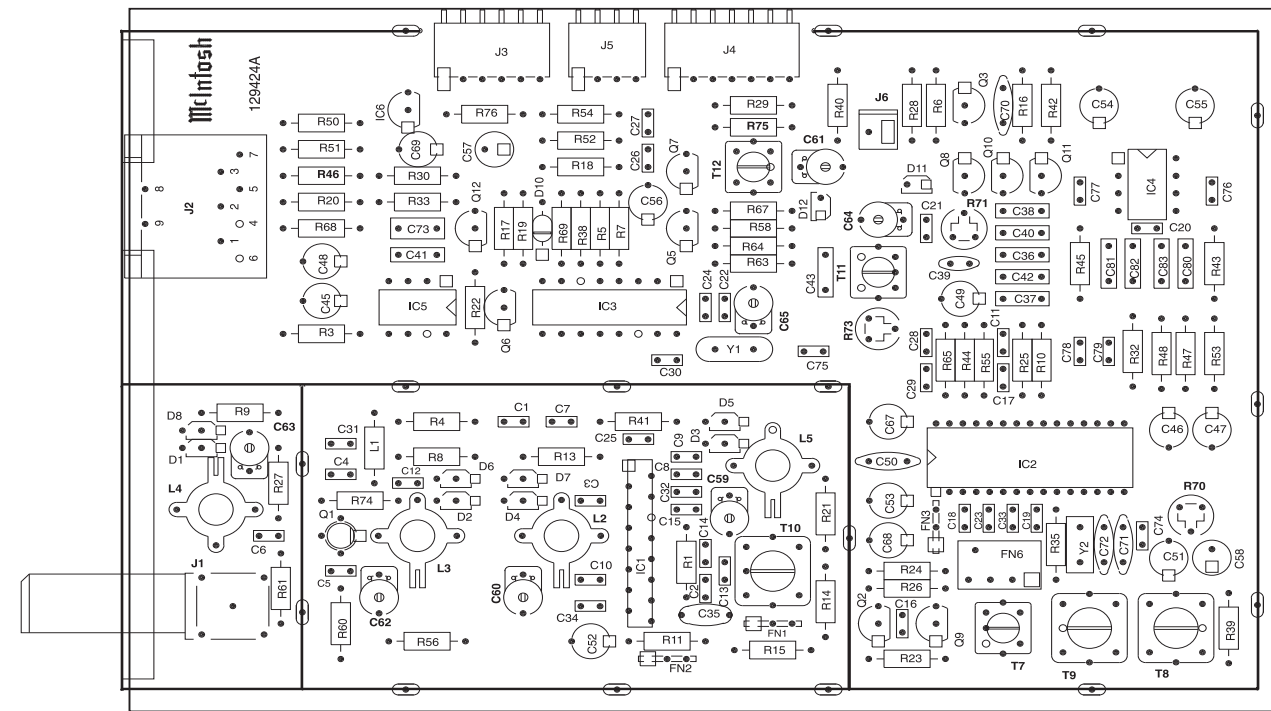

NOTE: SEE PAGE 105 - 106 FOR TUNER ALIGNMENT PROCEDURES

# 14 RAA1 SECTION

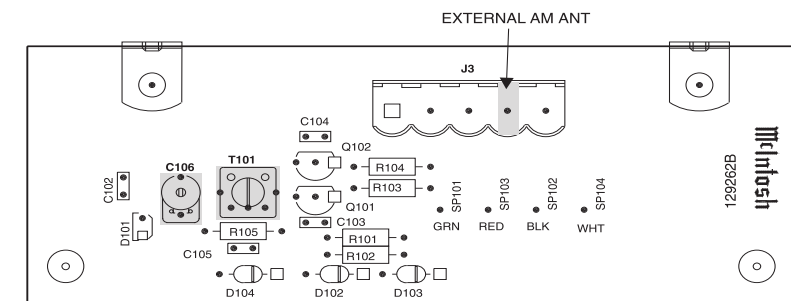
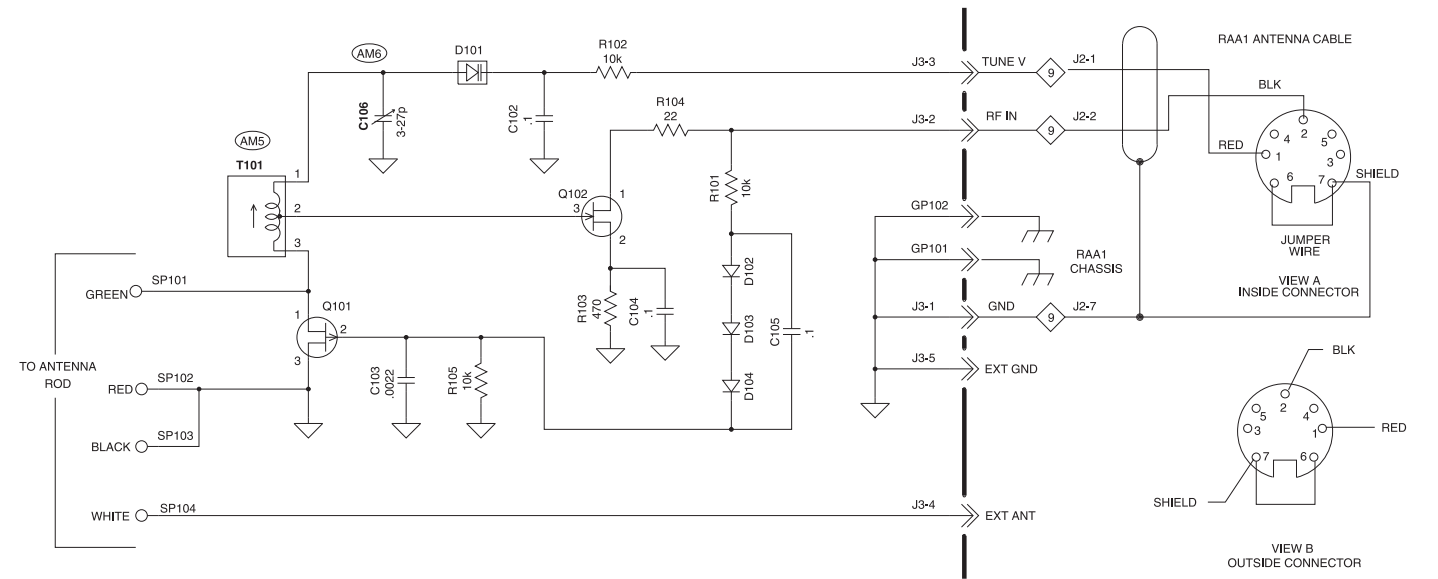



**15** *DSP MODULE* 320166

**MHT200**

**16** *BACKUP POWER SUPPLY* 320149

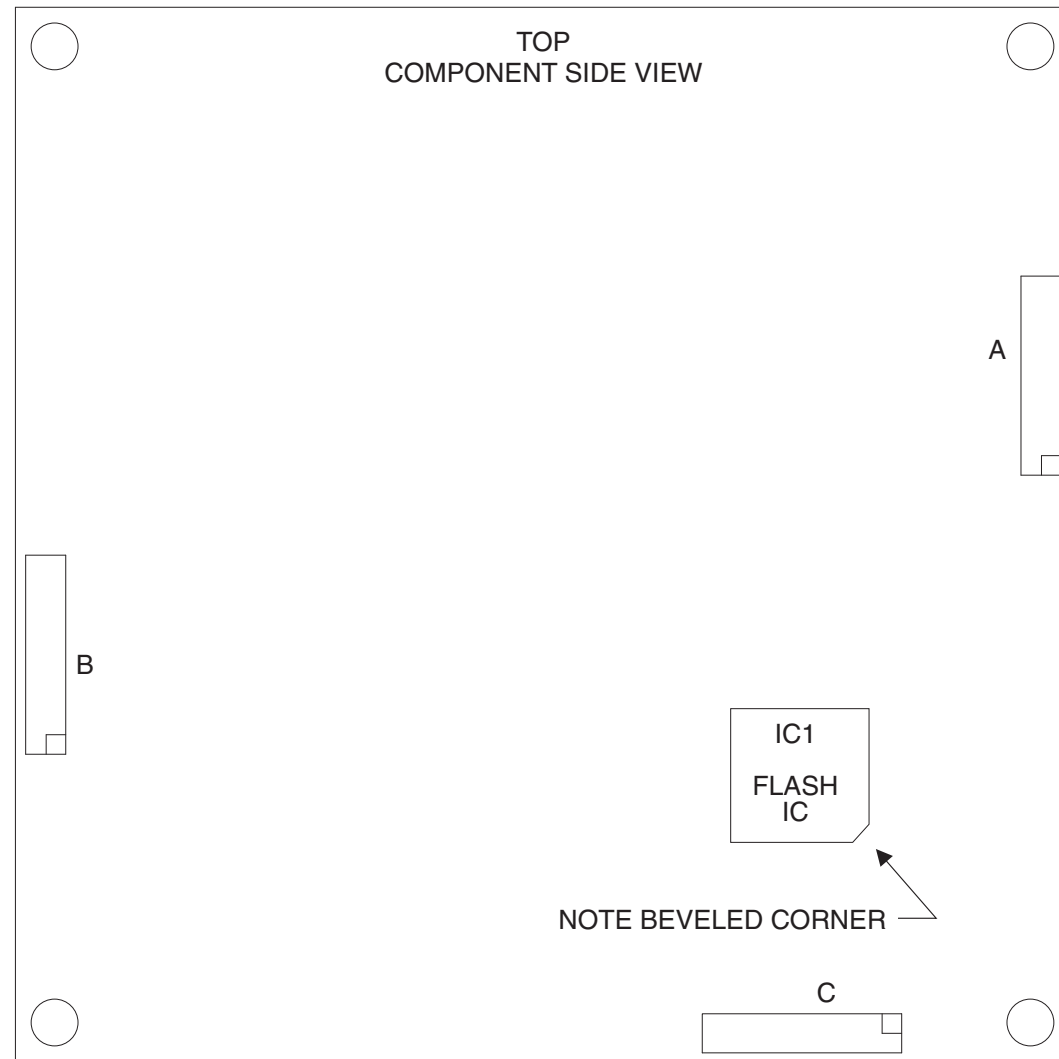

IC1  
 133506SP = BLANK IC  
 133507SP = MHT200 V6.44 PROGRAMMED IC

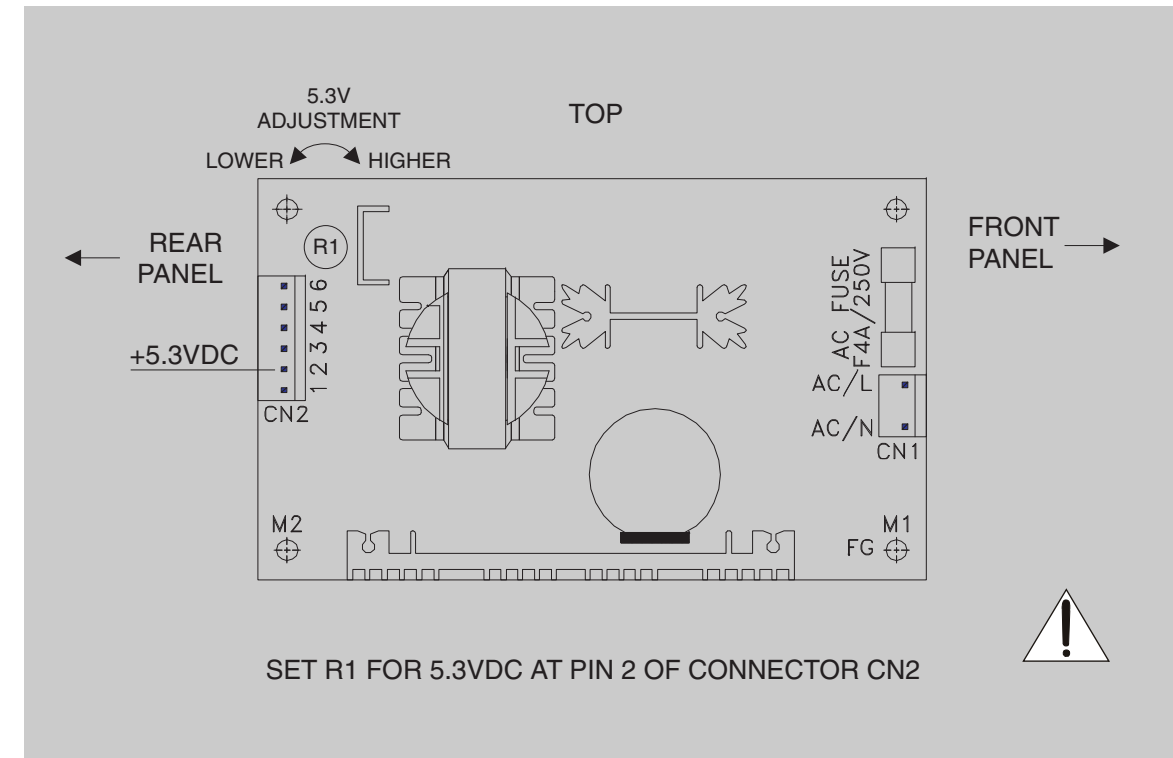

SET R1 FOR 5.3VDC AT PIN 2 OF CONNECTOR CN2

**!** **WARNING** Parts located in the shaded area have critical characteristics. Use only replacement parts recommended by the manufacturer.

# MHT200 EXPLODED VIEW and PARTS LIST

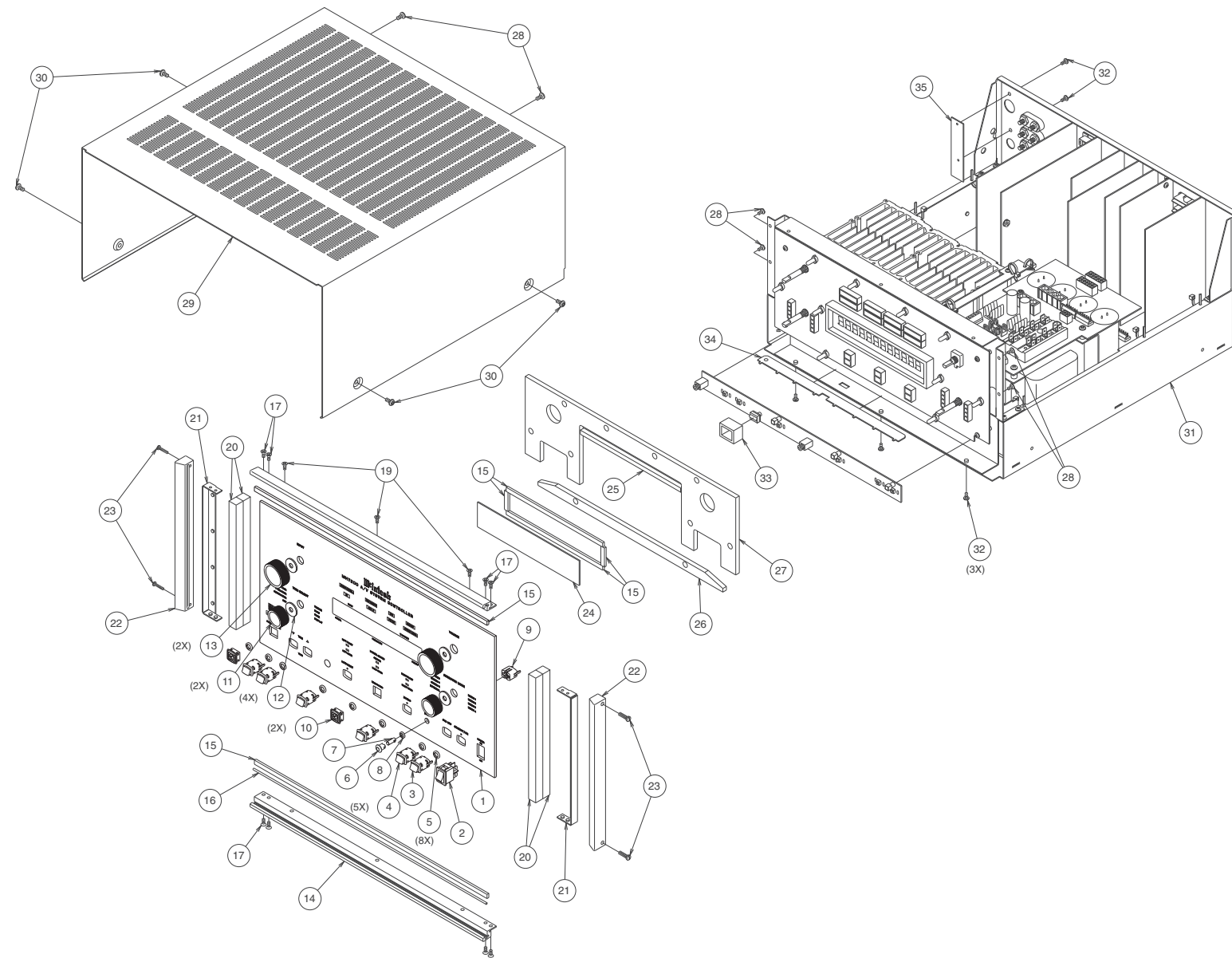

- |    |        |                                     |
|----|--------|-------------------------------------|
| 1  | 016489 | GLASS                               |
| 2  | 148073 | SWITCH DPDT ROCKER                  |
| 3  | 017531 | PUSHBUTTON ASSY RED                 |
| 4  | 017517 | PUSHBUTTON ASSY BLK                 |
| 5  | 078033 | O-RING                              |
| 6  | 017938 | BEZEL PUSHBUTTON                    |
| 7  | 017852 | PUSHBUTTON BLK                      |
| 8  | 078032 | O-RING                              |
| 9  | 017741 | RECEPTACLE PUSHBUTTON               |
| 10 | 017854 | BEZEL HEADPHONE                     |
| 11 | 049600 | ASSY KNOB 25.5mm                    |
| 12 | 104017 | WASHER FELT                         |
| 13 | 049598 | ASSY KNOB 35mm                      |
| 14 | 018706 | EXTRUSION BOTTOM                    |
| 15 | 094016 | TAPE FOAM 1/4 X 1/8                 |
| 16 | 098113 | CORD DIAL .027 BLACK BRAID SILK     |
| 17 | 100149 | SCREW MACH 6-32 X 1/4 FL U/H ST     |
| 18 | 018705 | EXTRUSION TOP                       |
| 19 | 101172 | SCREW TC 6-32 X 1/4 PH FL U/C       |
| 20 | 094360 | TAPE FOAM 1/2 X 1/2                 |
| 21 | 004939 | BRACKET EXTRUSION                   |
| 22 | 018615 | END CAP 9"                          |
| 23 | 101042 | SCREW TS 4-40 X 1/2 FILLISTER       |
| 24 | 017738 | PLEXIFILTER                         |
| 25 | 094017 | TAPE FOAM 1/4 X 1/4                 |
| 26 | 017851 | PUSHBUTTON DISPLAY PLEXI            |
| 27 | 017850 | PLEXIGLAS LOGO/TRIM/SURROUND        |
| 28 | 101054 | SCREW TAPTITE 6-32 X 1/4 PH PN BLK  |
| 29 | 005163 | TOP COVER                           |
| 30 | 101078 | SCREW TAP 8-32 X 5/16 PH PN BLK     |
| 31 | 320143 | MHT200 CONTROLLER SUBASSY           |
| 32 | 101109 | SCREW TAPTITE 6-32 X 5/16 PH PN BLK |
| 33 | 094443 | SENSOR GASKET                       |
| 34 | 017218 | PCB STIFFENER                       |
| 35 | 005078 | REAR PANEL PLUG                     |

# REPACKING INSTRUCTION

In the event it is necessary to repack the unit for shipment, the unit must be packed exactly as shown below.

**IMPORTANT** - The four plastic feet must be attached to the bottom of the unit so they will locate in the four holes of the bottom pad. Two #10 x 2-1/4" screws and washers must be used to fasten the unit securely to the bottom pad and wood skid. Failure to do this will result in shipping damage.

If a shipping carton or any of the interior parts is needed, please call or write the Customer Service Department of McIntosh Laboratory. Order parts from the accompanying list by part number.

Use the original shipping carton and interior parts only if they are in good serviceable condition.

Qty.	Part No.	Description
1	033160	Slit scored wrap
1	034198	Inner carton top
1	033725	Top pad
4	017218	Plastic foot (unit)
1	033739	Poly bag
4	100159	#10-32 x 3/4" Machine screw
4	104083	#10 x 7/16" Flat washer
1	034197	Bottom pad
2	017218	Plastic foot (spacer)
1	034196	Shipping skid
2	101169	#10 x 2-1/4" Wood screw
2	104033	#10 x 1-3/4" Flat washer
2	034159	Foam end caps
1	034158	Shipping carton
1	034199	Inner carton bottom

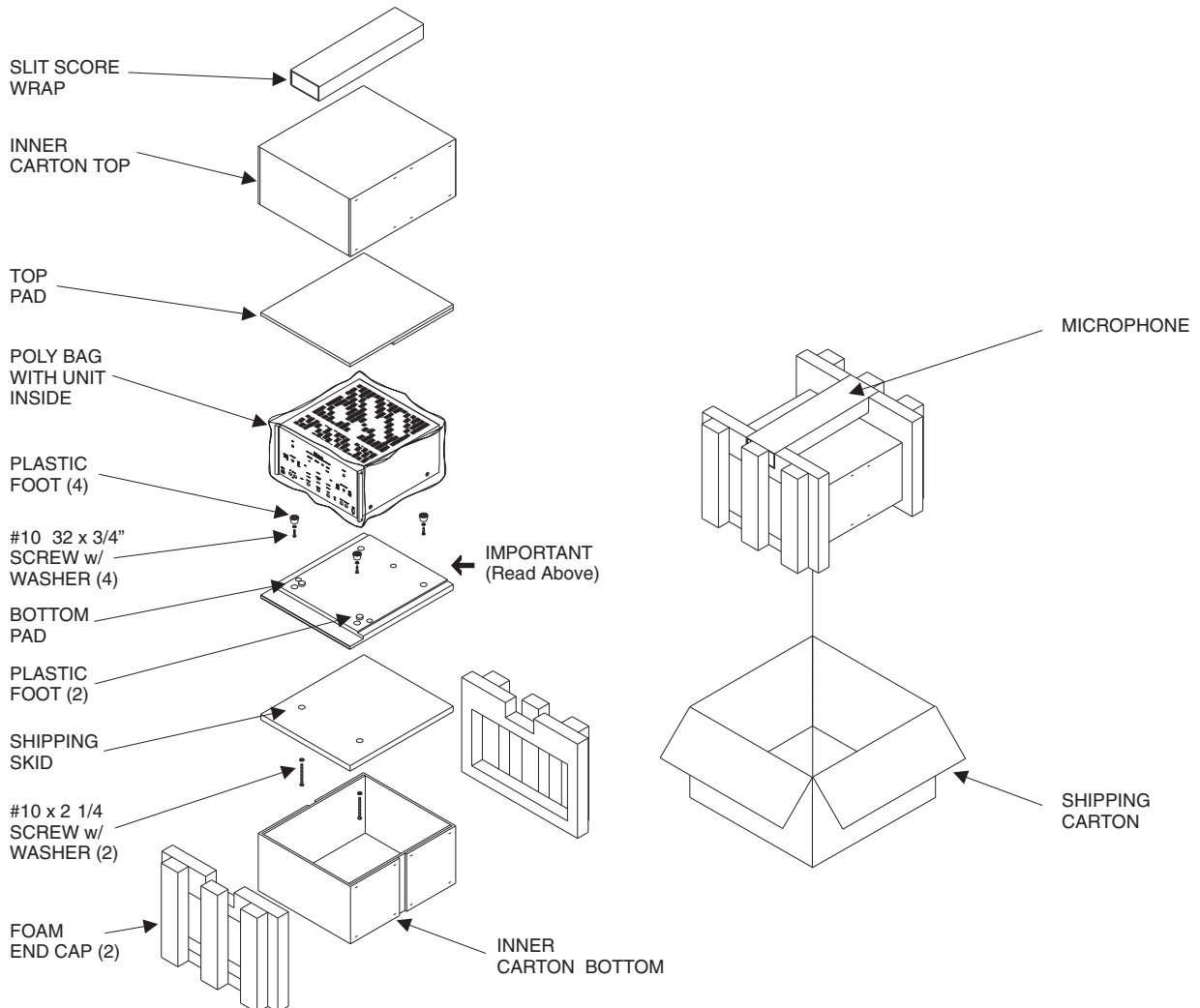

# MHT200

## A/V SYSTEM CONTROLLER

### SERVICE MANUAL



The continuous improvement of its products is the policy of McIntosh Laboratory Incorporated, who reserve the right to improve design without notice. Because of the constant upgrading of McIntosh products' circuitry and components, the Company cannot insure, and does not warrant, the accuracy of the within schematic material, which is intended for information only.