

McIntosh

MR 73

FM/AM TUNER

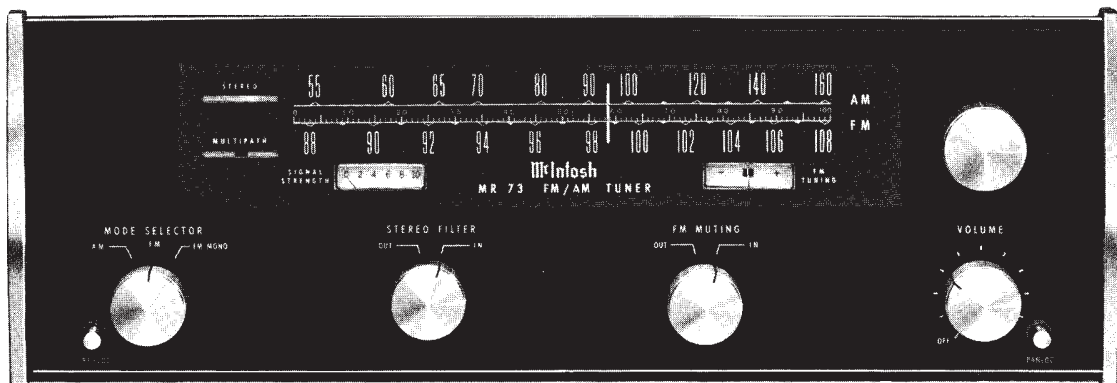

SERVICE INFORMATION

STARTING WITH SERIAL NO. 10T01

McINTOSH LABORATORY INC. 2 CHAMBERS STREET BINGHAMTON, NEW YORK

MR 73

FM TUNER SECTION

USEABLE SENSITIVITY

Better than $2.5\mu\text{V}$ (IHF useable sensitivity)

SIGNAL TO NOISE RATIO

Better than 70dB

HARMONIC DISTORTION

Mono, less than 0.3%. Stereo, less than 0.7%.

FREQUENCY RESPONSE

Flat from 20Hz to 20kHz with standard de-emphasis and 19kHz pilot filter

CAPTURE RATIO

Better than 1.5dB

SPURIOUS REJECTION

90dB or greater

IMAGE REJECTION

75dB or greater (at 100MHz)

STEREO SEPARATION

Better than 35dB at 1kHz.

SCA FILTER

Better than 50 dB rejection from 67kHz to 74kHz

AM TUNER SECTION

SENSITIVITY

Better than $12\mu\text{V}$ at 1000kHz (using external antenna input)

SIGNAL TO NOISE RATIO

Better than 55dB

HARMONIC DISTORTION

Less than 1% at 30% modulation

FREQUENCY RESPONSE

Down 6dB at 5kHz

SELECTIVITY

-30dB at 10kHz

IMAGE REJECTION

60dB or greater at 1000kHz

GENERAL

OUTPUT LEVEL

Fixed output, 2.5 volts
Variable output, 0 to 2.5 volts

POWER REQUIREMENTS

117 volts AC 50-60Hz, 20 watts

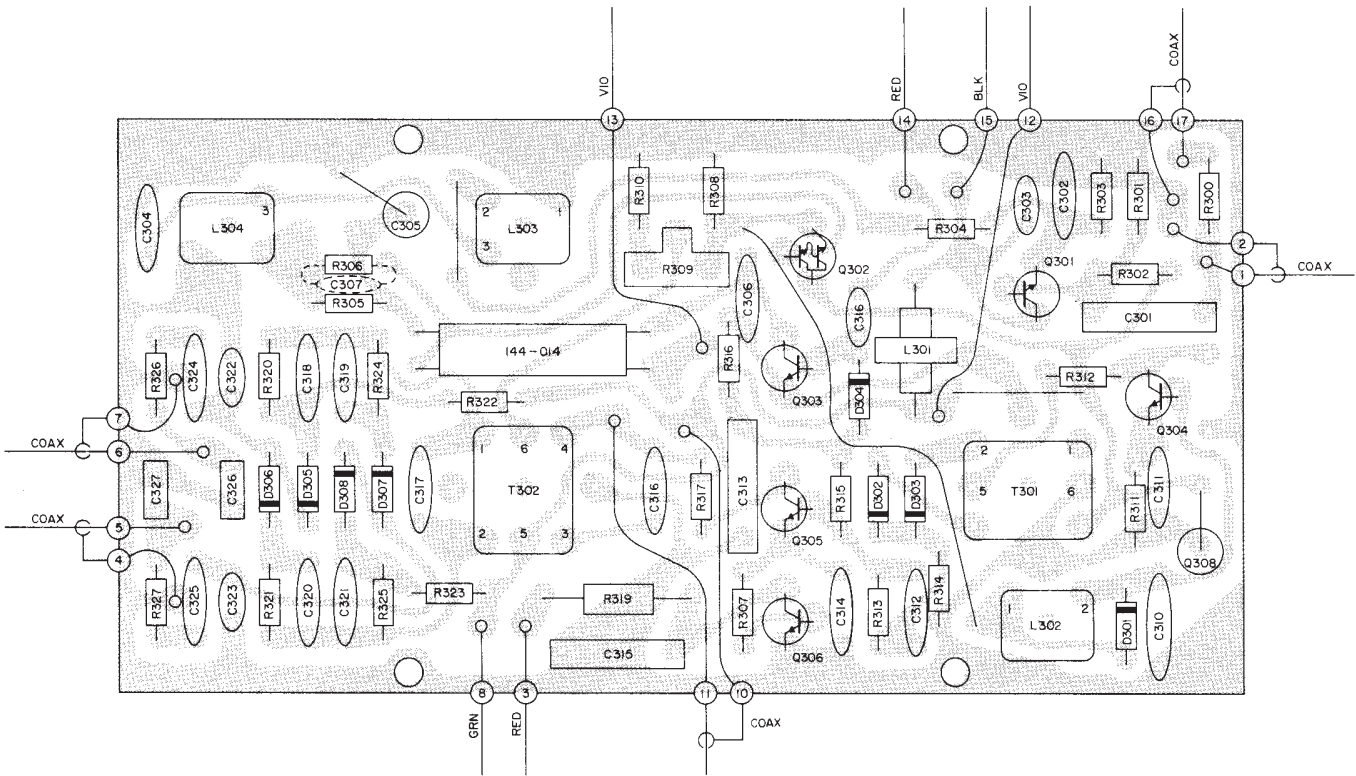

MPX PRINTED CIRCUIT BOARD 044-072

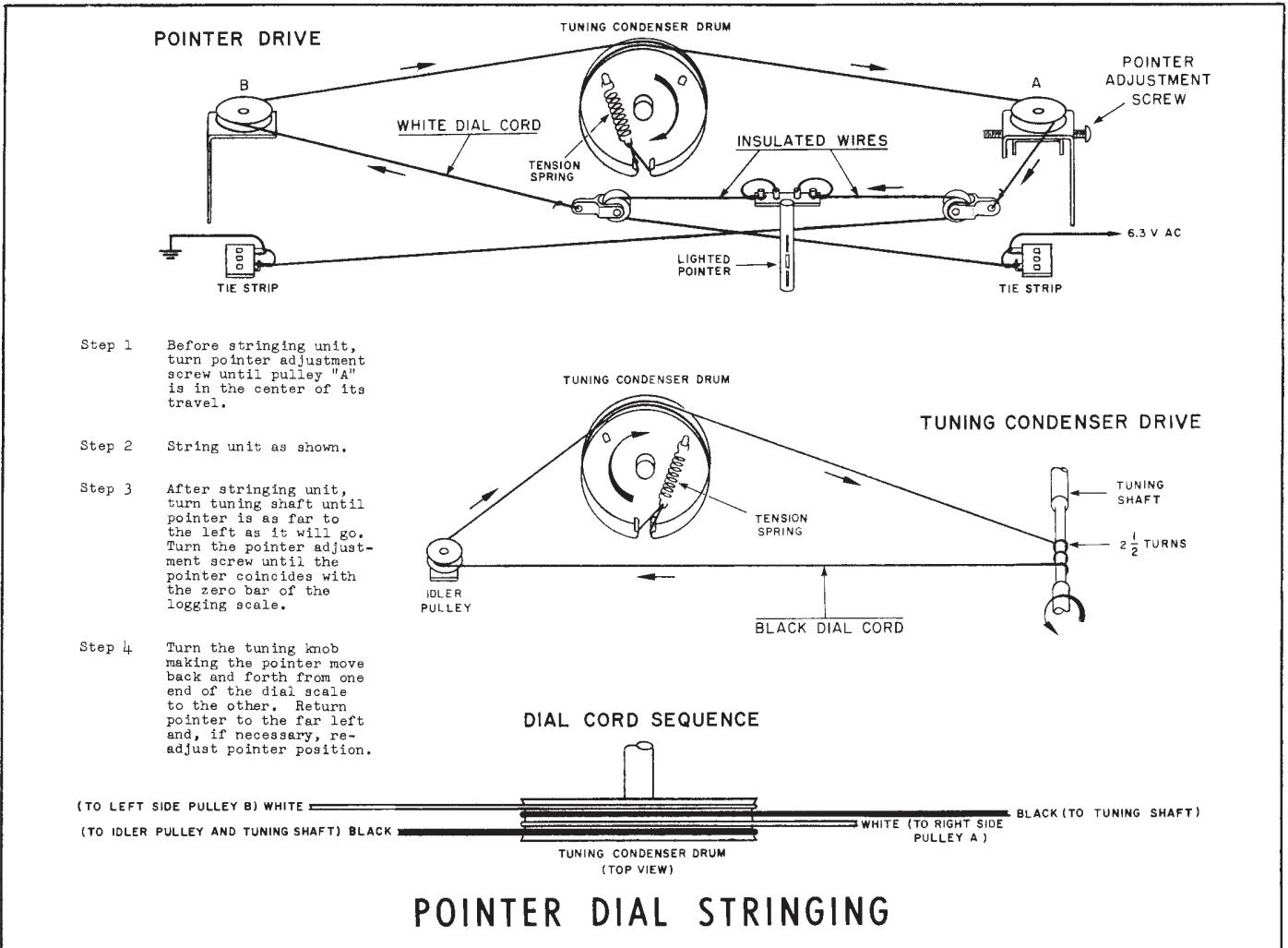

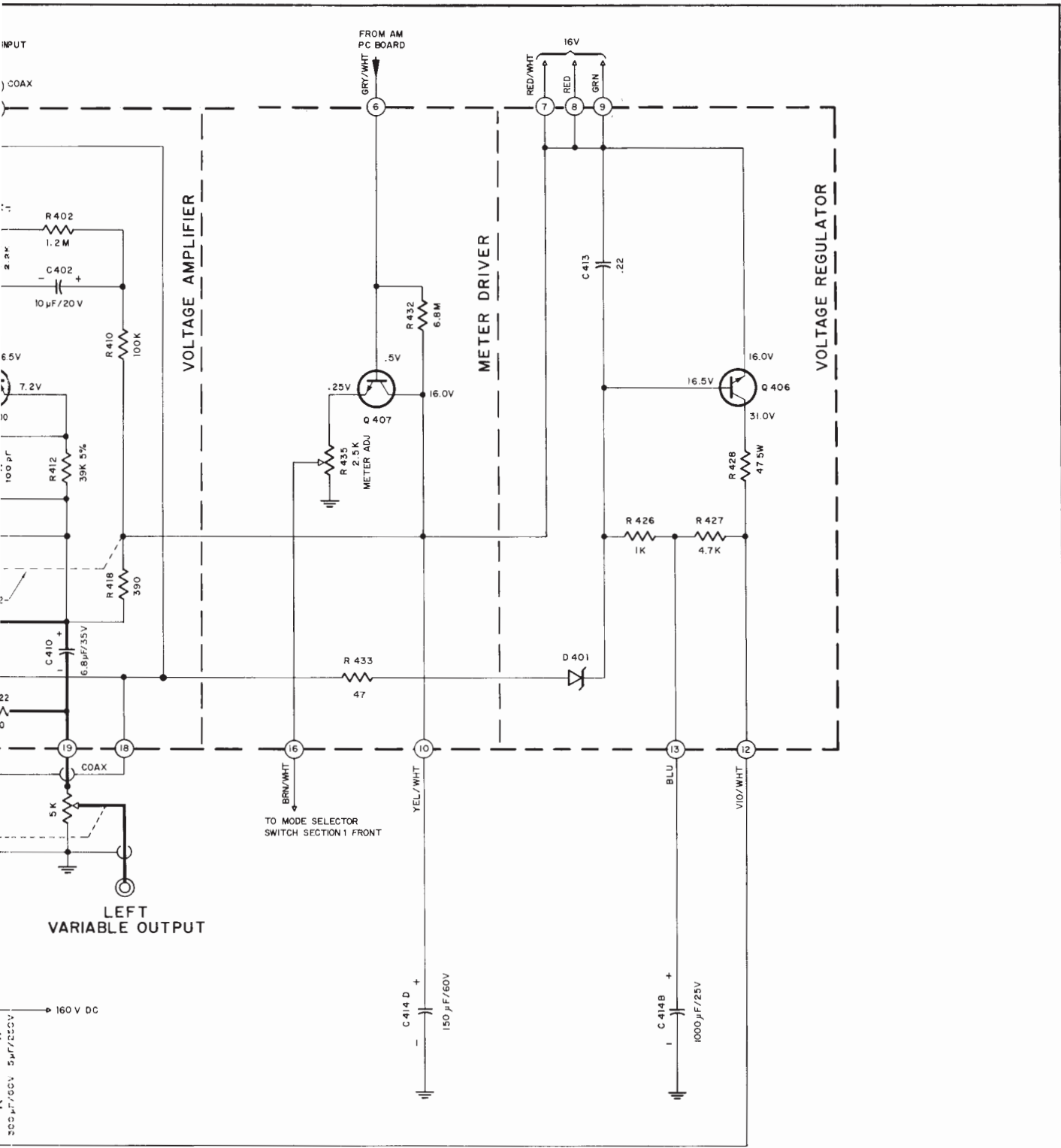

AMPLIFIER AND POWER SUPPLY SECTION

MR 73 154-437

SCHEMATIC NOTES

MR 73

1. Unless otherwise specified: Resistance values are in ohms, 1/4 watt, and 10% tolerance; capacitance values smaller than 1 are in microfarads (μF); capacitance values greater than 1 are in picofarads (pF); inductors are in microhenries (μH).
2. Printed circuit board components are outlined on the schematics by dotted lines. The circled numbers around the dotted lines correspond to the numbers on the PC Board layouts.
3. The heavy lines on the schematics denote the primary signal path.
4. The terminal numbering of rotary switches is for reference only.
5. All voltages indicated on the schematics are measured under the following conditions:
 - a. Use of an 11 megohm input impedance VTVM.
 - b. All voltages $\pm 10\%$ with respect to chassis ground.
 - c. No signal at input or antenna terminals.
 - d. AC input at 117 volts, 50/60 Hz.
 - e. Front panel controls at:

Tuning indicator	100MHz (no signal)	Mode	AM (to measure AM section)
Volume	Fully CW		Stereo (to measure FM section)
H. F. Filter	Out	Muting Adj.	MAX
Muting	Out	Panel Lights	Bright

6. In units with Serial No's below 15T33: R434 is not used.
7. In units with Serial No's below 15T74: R112 is 3.3k; R20 and C33 are used; R15 is connected as shown by dotted lines and center terminal of AM sensitivity switch (S2) is connected to ground as shown by dotted line.
8. In units with Serial No's from 24T00 to 33T50: C109 and C113 are not used; R106 is 680 Ω and XF-2 is McIntosh Part No. 044-045A.
9. In units with Serial No's below 33T50: R105 is 10k; R107 & R113 are 100 Ω 10%; C4 is 1.2pF and L5 is 1.2 μH .
10. In units with Serial No's below 27T84: R21 is not used.
11. In units with Serial No's below 33T50: R329 is not used; R307 is 200k; there is no connection from R307 to Pin 12 of MPX PC board and Pin 14 of MPX PC board is connected to the arm of R307 only.
12. In units with Serial No's below 33T50, PC board 043-975 is used. It connects the collector of Q402 and Q403 as shown by dotted line.

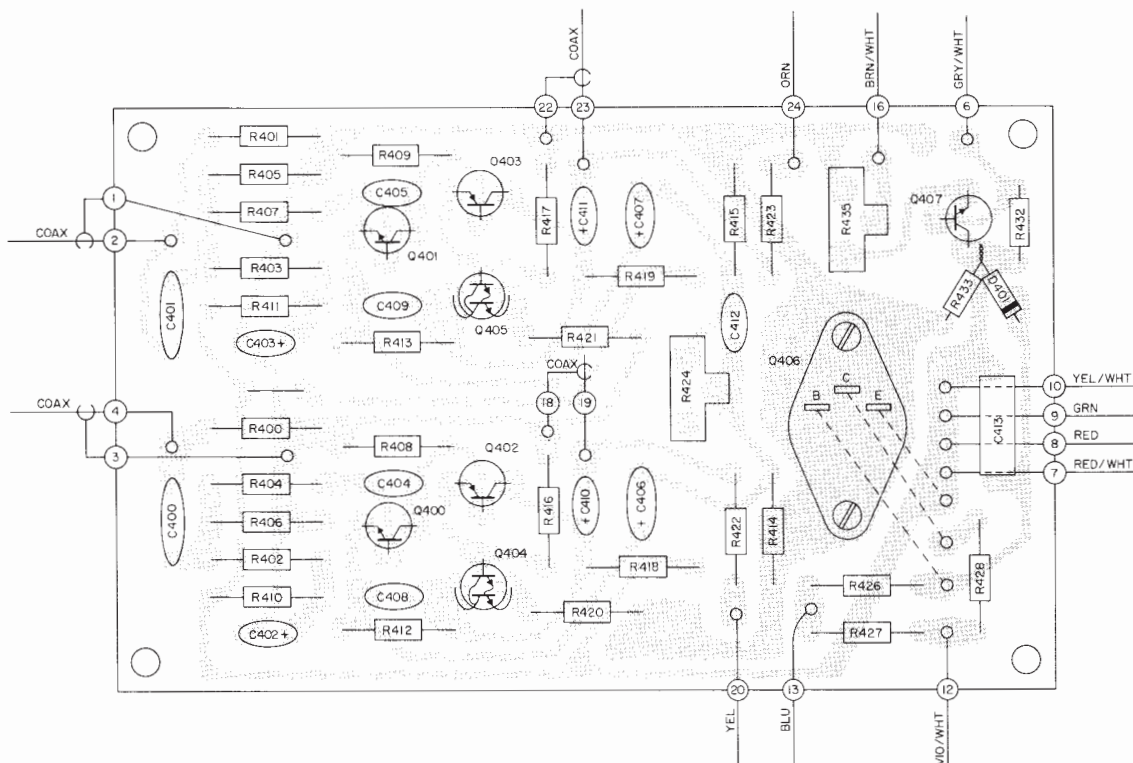

AMPLIFIER & VOLTAGE REG PC. BOARD 044-111

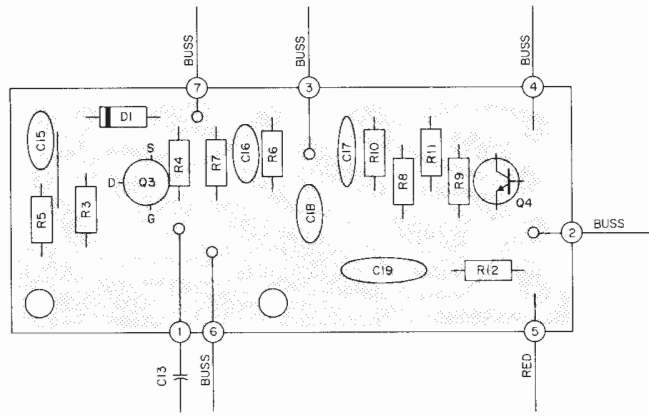

MIXER & LOCAL OSCILLATOR PC BOARD 044-038

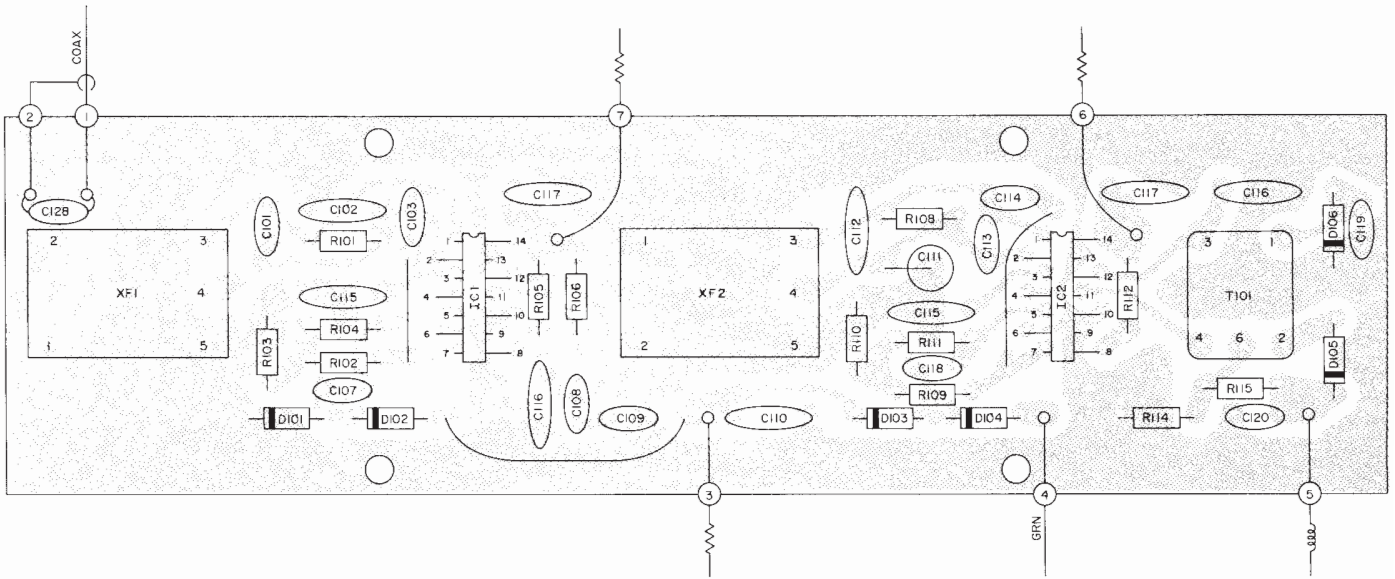

IF PRINTED CIRCUIT BOARD 043-973

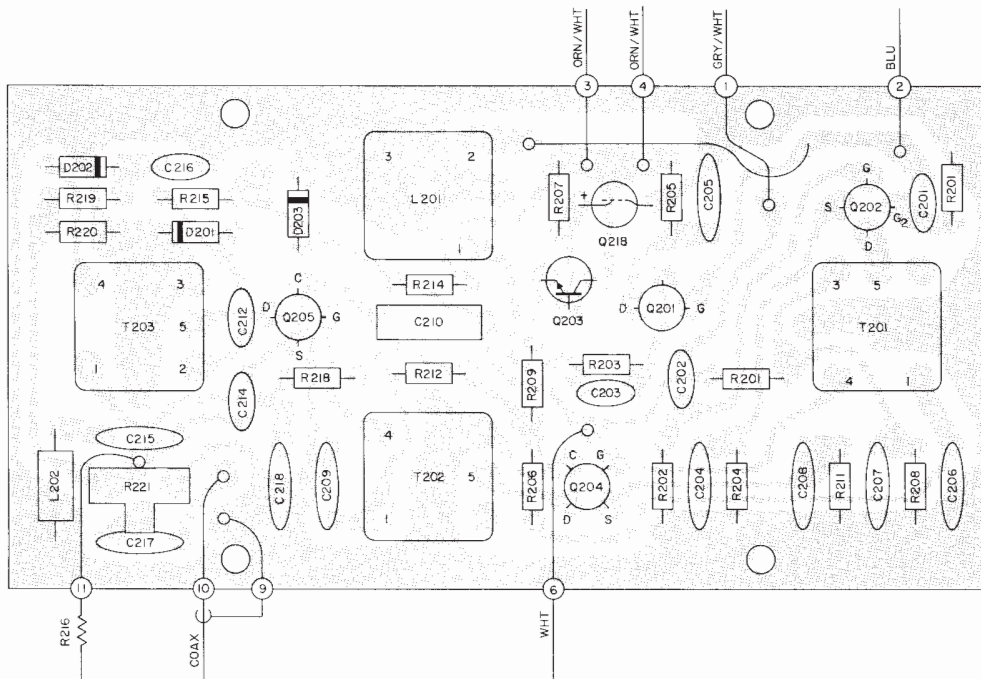

AM PRINTED CIRCUIT BOARD 044-071

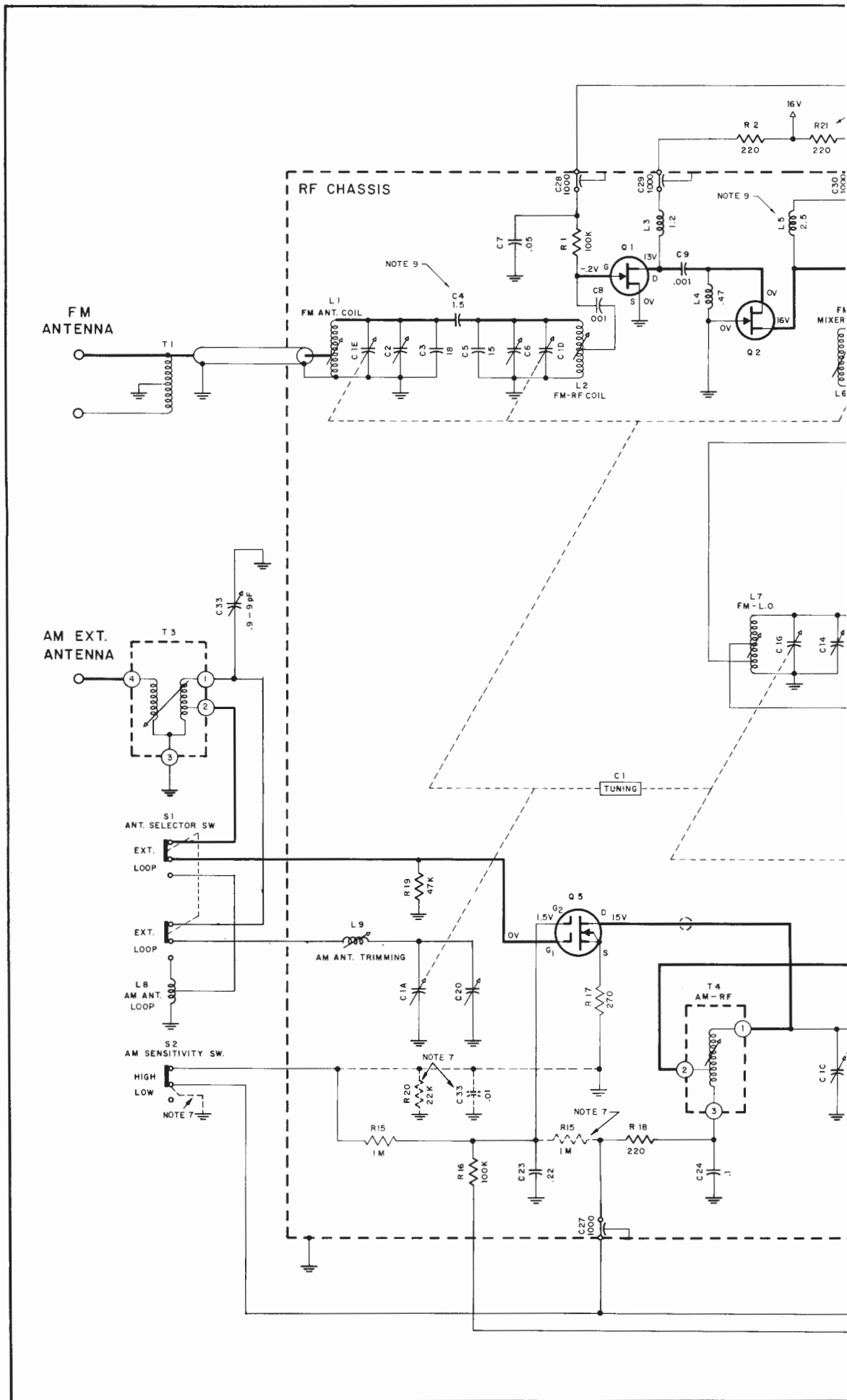

NOTE 10

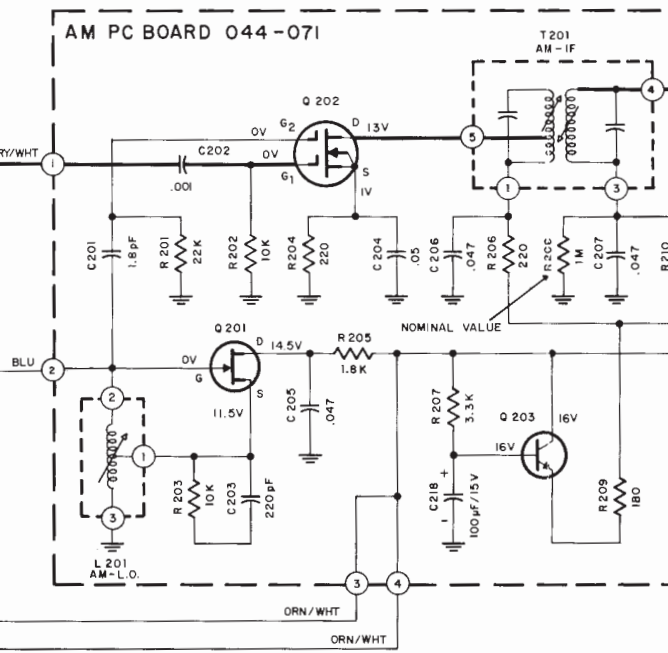
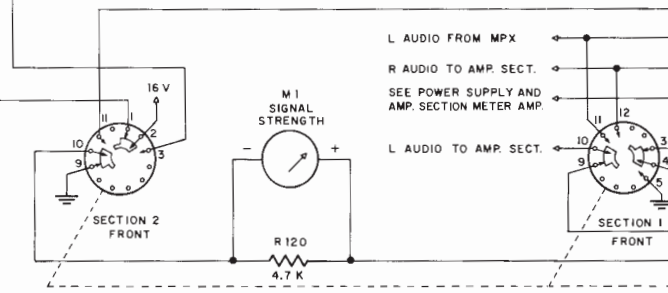
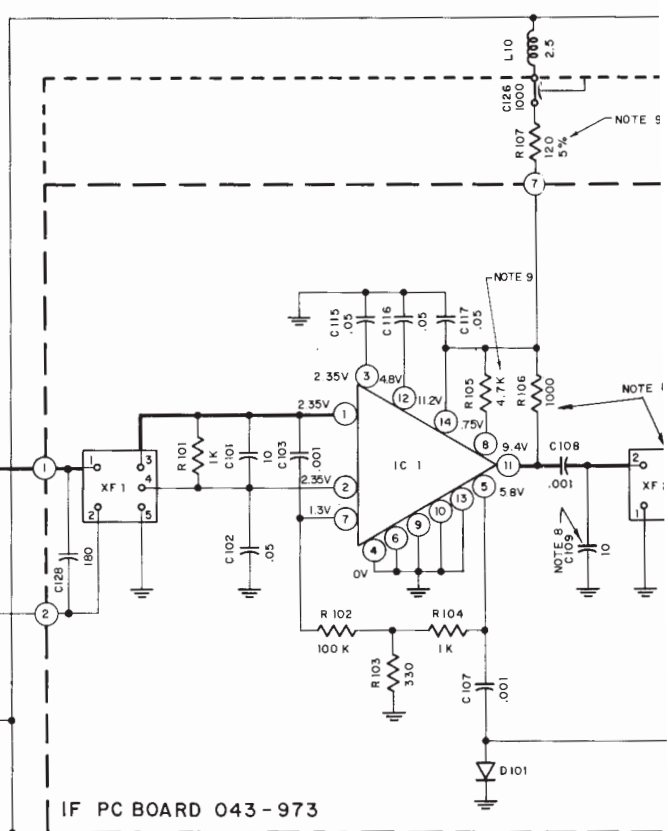
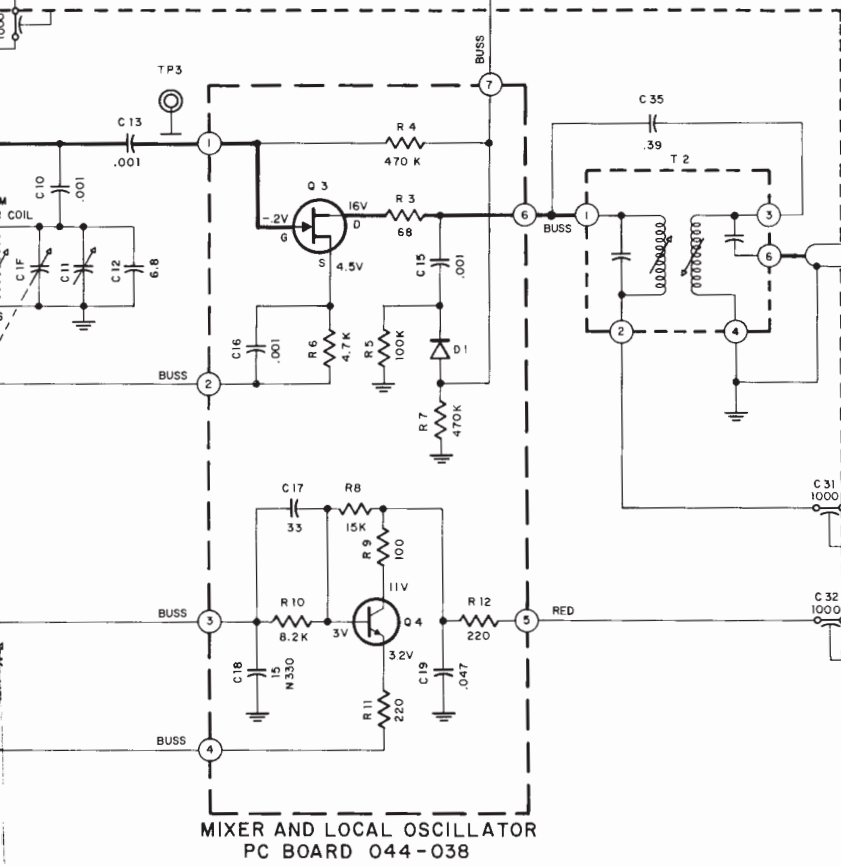

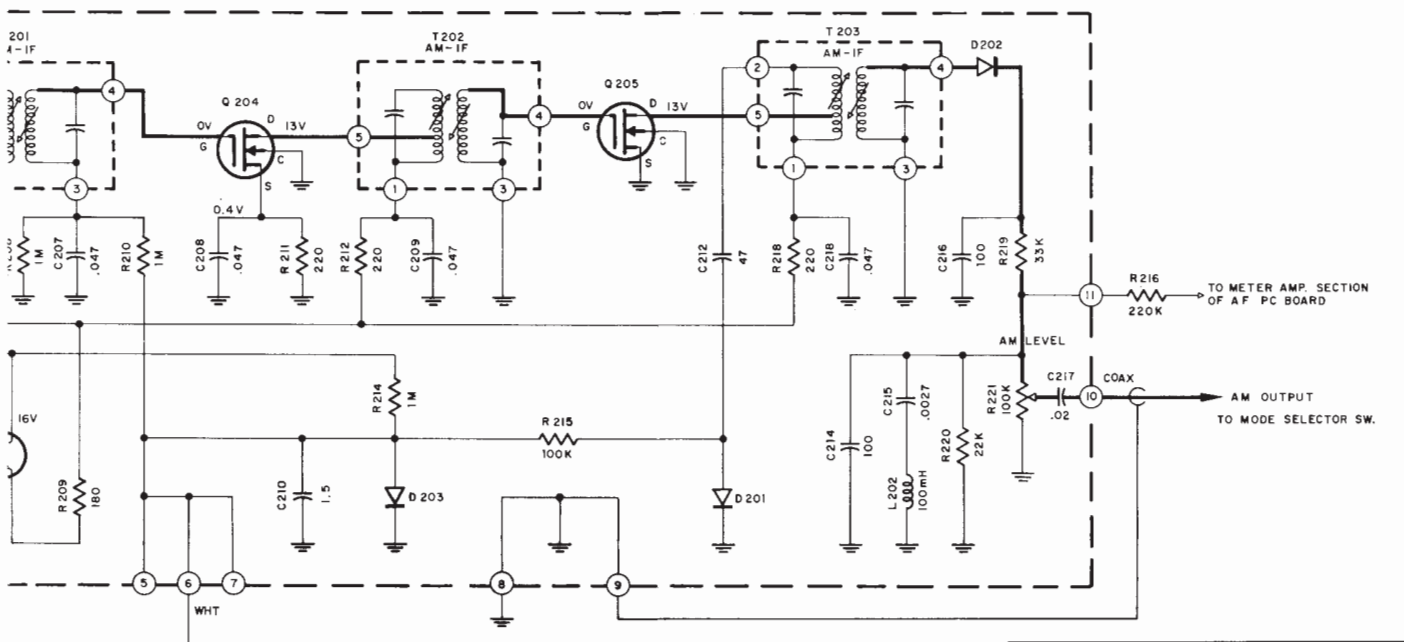
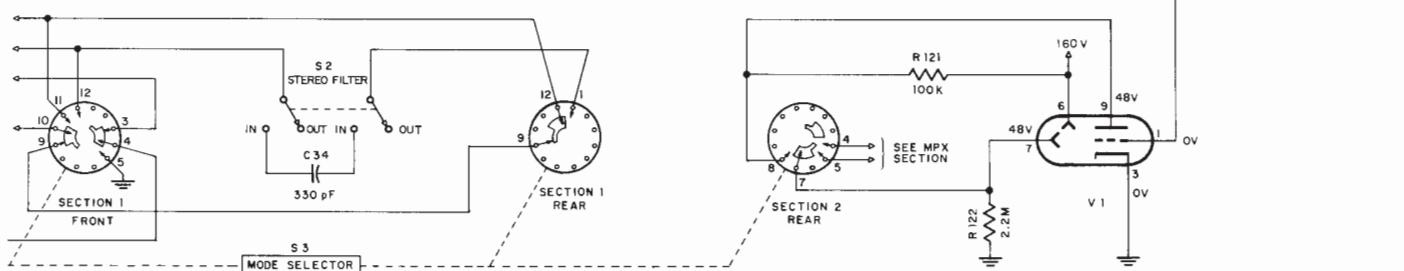
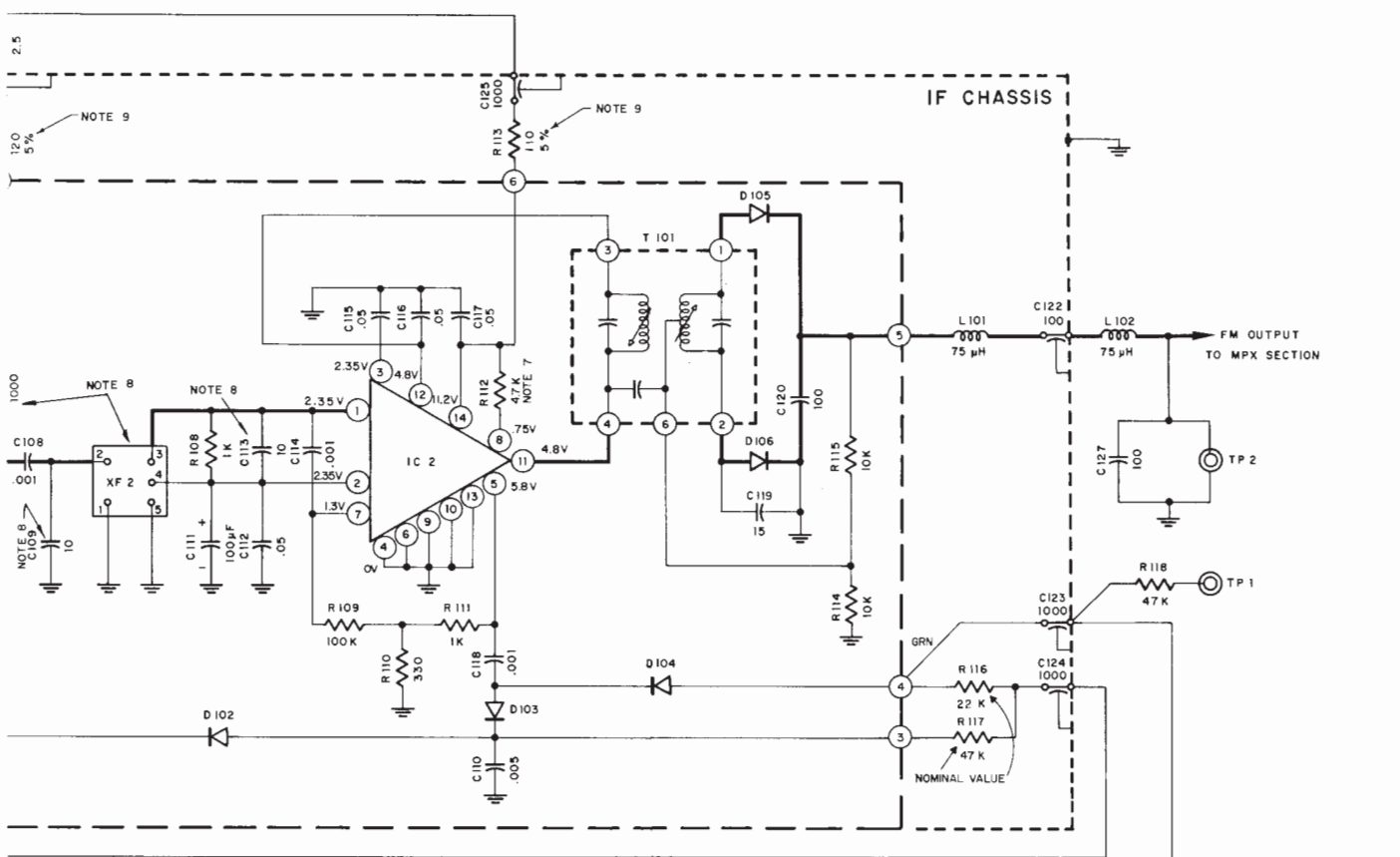

FM/AM TUNER SECTION

LAMP AND METER REPLACEMENT

To Replace Panel Lights

1. Remove bottom cover.

To Replace Dial Panel Lights

1. Remove knobs & front panel.

To Replace Stereo Light

1. Remove dust cover.

To Replace Multipath Light

1. Remove knobs & front panel.

To Replace Meters

1. Remove knobs & front panel.
2. Remove dial panel screws.
3. Tilt forward dial panel sliding off pointer.
4. Loosen meter screws & remove.

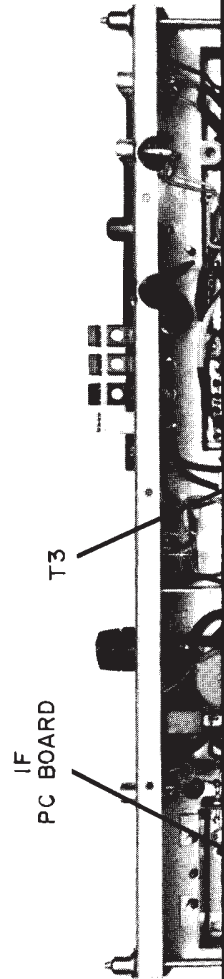

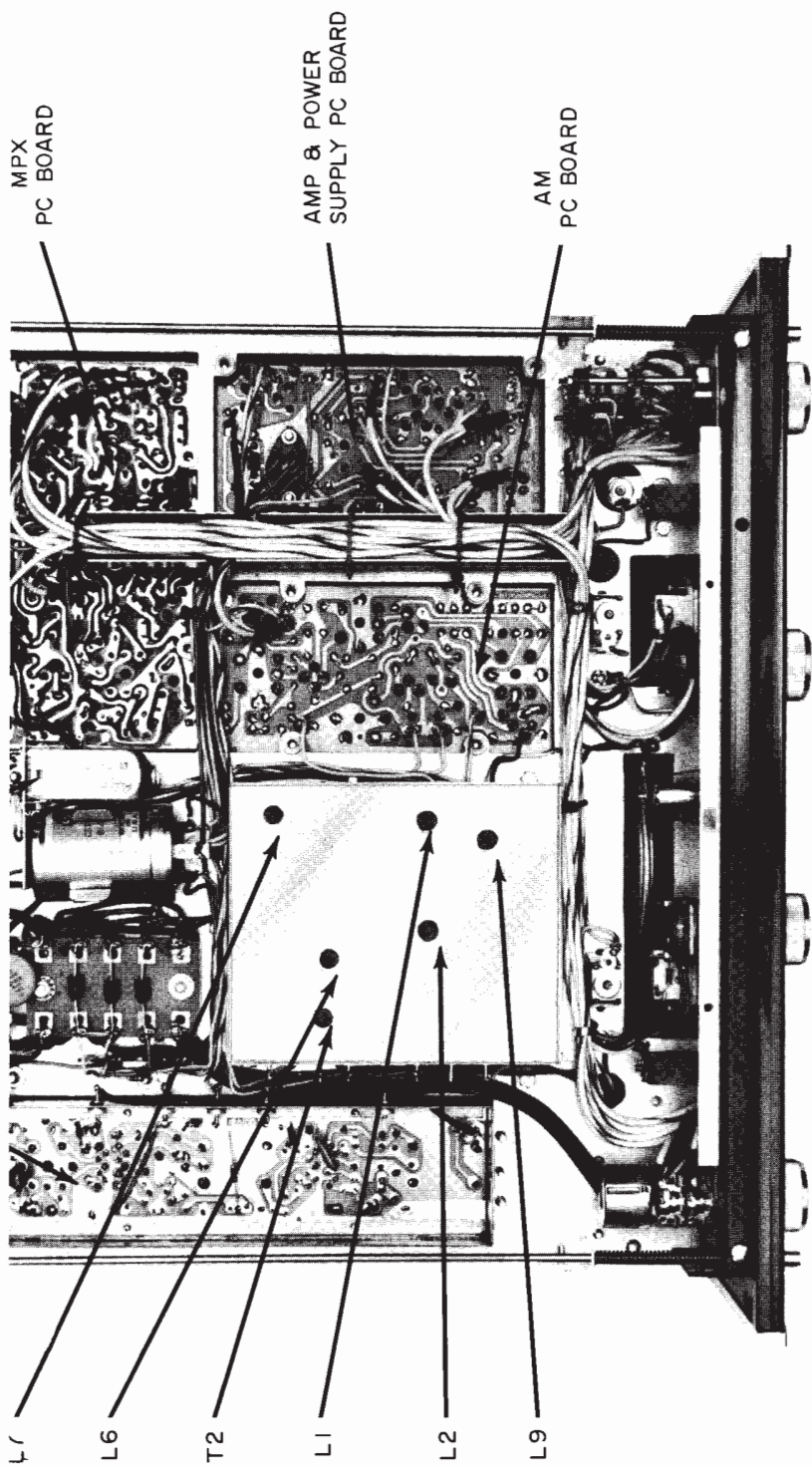

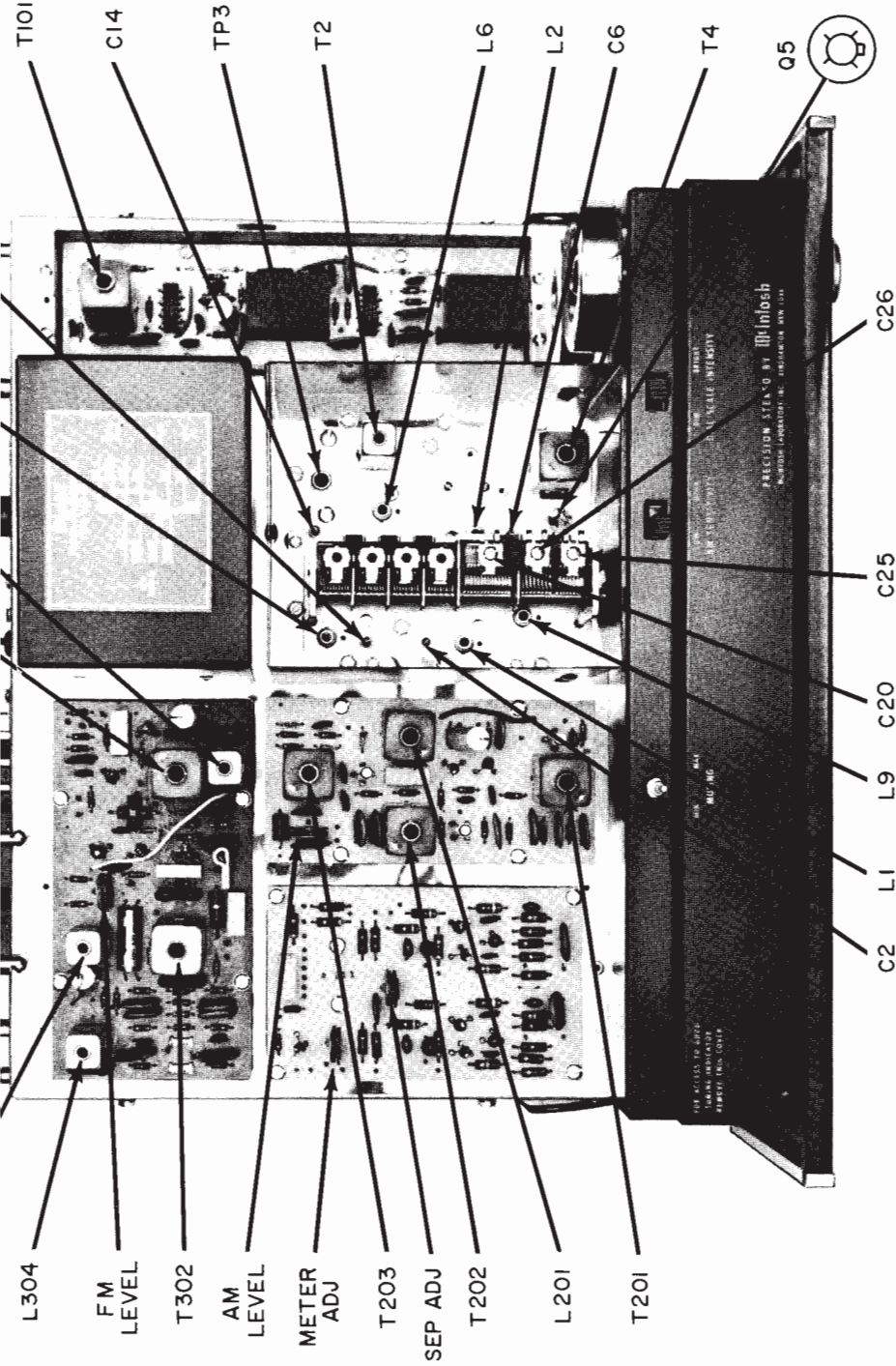

MR 73 ALIGNMENT INSTRUCTIONS

All McIntosh tuners are carefully aligned and tested at the factory using the finest available test equipment. All McIntosh tuners will meet their published specifications when shipped from the factory.

After extensive operation, or servicing, it may be desirable to realign the tuner circuits for best performance. The charts below give complete information on the circuit realignment procedure for the MR 73.

The test equipment listed (or its equivalent) is necessary to properly align an MR 73. The accuracy of the alignment will be directly related to the accuracy and calibration of the test equipment used.

If the necessary test equipment is not available, alignment should not be attempted. For additional information, contact Customer Service Department, McIntosh Laboratory Inc., 2 Chambers Street, Binghamton, New York 13903 (telephone 607-723-3512).

Alignment should be done in the following order: AM-FM-MPX

TEST EQUIPMENT REQUIRED

1. FM Signal Generator (Measurements 188 or equivalent)
2. AM Signal Generator (Measurements 65B or equivalent)
3. VTVM (RCA WV96C)
4. Multiplex Generator (Radiometer SMG1)
5. 10.7MHz Generator (preferably crystal controlled)
6. Oscilloscope (Hewlett-Packard L20B or equivalent)
7. Harmonic Distortion Analyzer (Hewlett-Packard 333A or equivalent)

AM ALIGNMENT

STEP	TUNER DIAL SETTING	SIGNAL GENERATOR			INDICATOR		ADJUST	TEST LIMITS	REMARKS
		FREQ.	COUPLING	MODULATION	TYPE	CONNECTED TO			
1	600kHz	4.5kHz	Through external .01 μ F capacitor to junction of C202 and T4 pin 2.	CW	VTVM	Pin 11 on AM circuit board.	Maximum possible positive voltage	Connect stator of OSC. Tuning capacitor (GIB) to ground with a jumper wire to make AM local oscillator inoperative. As the tuner output increases, attenuate generator output to keep voltage at VTVM below 0.5 volt.	
2	600kHz	600kHz	Through a 200pF capacitor to ant. terminals. Antenna switch in loop antenna position.	CW	Same	Same	Same	Same as step 1 except remove jumper from osc. section. Use a large signal from the signal generator because there is no direct connection from the generator to the loop antenna.	
3	1400kHz	1400kHz	Same	Same	Same	Same	Same	Repeat steps 2 & 3 until dial calibration is accurate.	
4	600kHz	600kHz	Same	Same	Same	Same	Same	Same as step 2 except adjust generator so that output signal is just above the noise level.	
5	1400kHz	1400kHz	Same	Same	Same	Same	Same	Repeat steps 4 & 5 until output is as high as possible.	
6	600kHz	600kHz	Same. Throw antenna switch to external antenna.	Same	Same	Same	Same	Reduce output of signal generator to a very low level to hold voltage at VTVM below 0.5 volt.	
7	1400 kHz	1400kHz	Same	Same	Same	Same	Same	Same	
8	1000kHz	1000kHz	Same	30% @ 400Hz	Distortion Analyzer	L or R output	With a distortion analyzer, the following measurements can be performed: 1. With a 1mV input signal adjust "AM Level" control (R49) for 0.8 volts of audio output at tape-outputs. This will correspond to 2.5 volts audio output for a 100% modulated signal. 2. With a 1mV input signal, harmonic distortion, whistle filter attenuation at 10kHz modulating frequency and signal to noise ratio may be measured. 3. IFPM sensitivity of 20 microvolts for -20dB of signal to noise ratio. (this measurement is only possible in the absence of man-made interference, as fluorescent lamps, etc.)		

FM ALIGNMENT

STEP	TUNER DIAL SETTING	SIGNAL GENERATOR			INDICATOR		ADJUST	TEST LIMITS	REMARKS
		FREQ.	COUPLING	MODULATION	TYPE	CONNECTED TO			
1	Point of no interference or signal	10.7MHz	T0 TP-3	FM \pm 200kHz sweep at 60 Hz rate	Oscilloscope	TP # 1	Optimum symmetry about 10.7 Mhz and cores of T2	Connect scope for IF response display. Hold the signal generator output to a low level such that the DC voltage at TP #1 is about -0.5 volts.	

STEP	DIAL SETTING	SIGNAL GENERATOR			INDICATOR			ADJUST	TEST LIMITS	REMARKS
		FREQ.	COUPLING	MODULATION	TYPE	CONNECTED TO				
1	Point of no interference or signal	10.7MHz	TO TP-3	FM ±200kHz sweep at 60 Hz rate	Oscilloscope	TP # 1	Top (primary) and bottom (secondary) cores of T2	Optimum symmetry about 10.7 MHz and 10.7MHz ± 5kHz markers.	Connect scope for IF response display. Hold the signal generator output to a low level such that the DC voltage at TP #1 is about -0.5 volts.	
2	Same	10.7MHz	Same	CW	VTVM	Pin 6 of T101 through 1 meg. resistor.	T101 primary bottom core	Maximum possible negative voltage		
3	Same	Same	Same	Same	Same	TP # 2	T101 secondary top core	Adj. for 0 volts		
4	105MHz	105 MHz	300 ohm antenna terminals w/matching network	400Hz 75kHz deviation	VTVM	connected to TP# 1 and scope connected to L or R audio output	Oscillator Trimmer, C14	Maximum negative voltage		
5	90MHz	90MHz	Same	Same	Same		Oscillator Coil, L7	Same	Same. Repeat Steps 4 and 5 until dial is accurate.	
6	105 MHz	105MHz	Same	Same	Same		Mixer-Trimmer, RF Trimmer & Antenna-Trimmer C11, C6, C2	Same	As the circuits align reduce this input signal to hold the voltage at TP#1 to -2 volts or less.	
7	90MHz	90MHz	Same	Same	Same		Mixer, RF and antenna tuning cores L6, L2, L1	Same	Same. Repeat Steps 6 and 7 until TP #1 is as high as possible at odd alignment frequencies.	
8	90MHz	90MHz	Same	Same	Harmonic Distortion Analyzer connected to L or R output.		T101 primary bottom core.	Adj. for minimum distortion	Apply 1 MV input signal. Adjust T-01 bottom core for minimum distortion. Should be less than 0.3%.	
9	90MHz	90 MHz	Same	10kHz, 75kHz, deviation	Same		T2 top and bottom	Adj. for minimum distortion	Readjust very slightly (less than 1/8 turn) T2 top and bottom cores for minimum distortion. If further adjustment seems necessary, recheck step # 1.	
10	90 MHz	90 MHz	Same	400 Hz 75 kHz deviation.	Same		R307 muting control		Apply 5 µV input signal. Place front panel muting switch in "IN" position. Adjust R307 muting control from CCW position until the audio output drops 2 dB. Return muting switch in "OFF" position.	
11	90MHz	90MHz	Same	Same	Same				This step is an overall sensitivity check. Reduce input signal to the point where total noise and distortion reads 3% (-30dB). The input signal will then be the maximum usable sensitivity and should be less than 2.5µV.	

MULTIPLY DECODER ALIGNMENT

STEP	TUNER DIAL SETTING	SIGNAL GENERATOR			INDICATOR			ADJUST	TEST LIMITS	REMARKS
		FREQ.	COUPLING	MODULATION	TYPE	CONNECTED TO				
1	100MHz	3000 antenna terminals w/ approx. 1000 microvolts signal w/matching network	75kHz Deviation @ 67kHz	AC-VTVM	L or R output jack	L303 and L304 (SCA adj.)	Minimum output @ L or R output jack.	Adjust for minimum output with 67kHz modulation.		
2	100MHz	Same	19kHz stereo pilot	AC-VTVM or oscilloscope w/very low cap.	T301, pin 2 or 3.	L302 (19kHz phase adj.) & T301 (19 kHz doubler)	Adjust for maximum AC voltage	Decrease pilot level, if necessary, so that 19kHz circuits do not limit or saturate.		

MULTIPLY DECODER ALIGNMENT

STEP	TUNER DIAL SETTING	SIGNAL GENERATOR			INDICATOR		ADJUST	TEST LIMITS	REMARKS
		FREQ.	COUPLING	MODULATION	TYPE	CONNECTED TO			
1	100MHz	100MHz	300Ω antenna terminals w/ approx. 1000 microvolts signal w/* matching network	75kHz Deviation @ 67kHz	AC-VTVM	L or R output jack	L303 and L304 (SCA adj.)	Minimum output @ L or R output jack. Adjust for minimum output with 67kHz modulation.	
2	100MHz	100MHz	Same	19kHz stereo pilot	AC-VTVM or oscilloscope w/very low cap. probe.	T301, pin 2 or 3.	L302 (19kHz phase adj.) & T301 (19 kHz doubler)	Decrease pilot level, if necessary, so that 19kHz circuits do not limit or saturate.	
3	Same	Same	Same	Same	Same	T302, Pin1 or 2.	T302 (Pri) & Adj. for bottom (Sec) maximum AC tuning slugs voltage	Decrease pilot level so that 19kHz and 38kHz circuits do not limit. Mode switch must be in stereo position.	
4	Same	Same	Same	1kHz (100% modulation) L or R only, pilot level normal and on.	Same	L or R output jack	T302, Bottom tuning slug. Also adj. R424	First, set R424 to MAX resistance. Modulate left channel and measure right channel output. Adjust T302 bottom - tuning slug (Sec.) for minimum right channel output. (maximum separation). Then adjust R424 for maximum separation. Repeat the adjustment of T302 bottom and R424 until maximum separation is obtained. Then, reverse channels and measure left channel separation. For this adjustment and measurement, no test lead should be connected to T302.	
5	100MHz	100MHz	Same	1kHz (100% modulation) L or R only, pilot on	AC-VTVM	L or R output jack		Adjust "FM-Level" control (R307) for 2.5 volts of audio output at fixed output jacks. Then, turn off the modulation and measure the residual of the 19kHz and 38kHz frequencies.	

Note 1 : If signal Generator has other than 50 ohm internal impedance, use a resistor of 150 ohms less internal generator impedance.

* ANTENNA MATCHING NETWORK

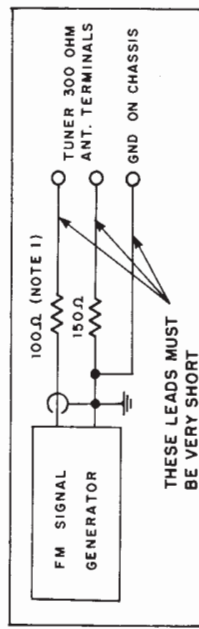

REPLACEMENT PARTS

All parts not listed are common items obtainable from radio parts jobbers.

Replacement parts may be obtained when ordered by PART NUMBER from:

McIntosh Laboratory, Inc.
Customer Service Department
2 Chambers Street
Binghamton, New York 13903
(telephone 607-723-3512)

Symbol Number	CAPACITORS			Part Number
	Description			
C23	Mylar	22 μ F	200V	064-087
C24	Mylar	.1 μ F	250V	064-086
C111	Elect.	100 μ F	15V	066-127
C210	Tant. Elect.	1.5 μ F	35V	066-092
C218	Elect.	100 μ F	15V	066-127
C301	Mylar	.22 μ F	50V	064-068
C305	Elect.	100 μ F	15V	066-127
C308	Elect.	100 μ F	15V	066-127
C313	Mylar	.1 μ F	250V	064-067
C315	Mylar	.22 μ F	250V	064-068
C402,403	Elect.	10 μ F	20V	066-149
C406,407	Elect.	22 μ F	20V	066-148
C410,411	Elect.	6.8 μ F	35V	066-146
C413	Mylar	.22 μ F	250V	064-068
C414	Elect.	5/300/150/1000 250/60/60/25		066-145
DIODES				
D1	Ge. signal diode			070-003
D101,102	Ge. signal diode			070-003
D103,104	Ge. signal diode			070-003
D105,106	Si. signal diode			070-022
D201	Ge. signal diode			070-003
D202,203	Ge. signal diode			070-003
D301	Bias diode			070-046
D302,303	Si. signal diode			070-022
D304	Si. signal diode			070-022
D305,306	Ge. signal diode			070-003
D307,308	Ge. signal diode			070-003
D401	Zener diode 16V			070-048
D402,403	Si. rectifier			070-031
D404	Si. rectifier			070-031
FUSES				
F200	Fuse	.5A Slo-Blo		089-020

CHOKES

L1	FM antenna coil	122-069
L2	FM RF coil	122-070
L3	Choke 1.2 μ H	122-011
L4	Choke .47 μ H	122-010
L5	Choke 2.5 μ H	122-033
L6	FM mixer coil	122-071
L7	FM local oscillator coil	122-072
L8	AM Loop antenna	122-074
L9	AM antenna trimming coil	122-073
L10	Choke 2.5 μ H	122-033
L101,102	Choke 75 μ H	122-013
L201	AM oscillator coil	122-066
L202	Choke 100MH	122-004
L301	Choke 1mH	122-065
L302	Filter coil (19kHz phase)	122-080
L303,304	Filter coil (SCA)	122-079

TRANSISTORS

Q1,2	Si. junction F.E.T.	132-049
Q3	Si. junction F.E.T.	132-049
Q4	Si. NPN transistor	132-015
Q5	Si. M.O.S. F.E.T.	132-064
Q201	Si. junction F.E.T.	132-049
Q202	Si. M.O.S. F.E.T.	132-064
Q203	Si. NPN transistor	132-041
Q204,205	Si. M.O.S. F.E.T.	132-061
Q301	Si. NPN transistor	132-057
Q302	Si. NPN transistor	132-052
Q303,304	Si. NPN transistor	132-057
Q305	Si. NPN transistor	132-057
Q306	Si. NPN transistor	132-042
Q400,401	Si. PNP transistor	132-056
Q402,403	Si. NPN transistor	132-041
Q404,405	Si. NPN transistor	132-052
Q406	Si. NPN transistor	132-072
Q407	Si. NPN transistor	132-041

POTENTIOMETERS

R221	AM level control	134-177
R244	Volume control	134-217
R307	Muting control	134-216
R309	FM level control	134-197
R424	Separation adjust	134-212
R435	Meter adjust	134-197

CHOKES

FM antenna coil	122-069
FM RF coil	122-070
Choke 1.2 μ H	122-011
Choke .47 μ H	122-010
Choke 2.5 μ H	122-033
FM mixer coil	122-071
FM local oscillator coil	122-072
AM Loop antenna	122-074
AM antenna trimming coil	122-073
Choke 2.5 μ H	122-033
Choke 75 μ H	122-013
AM oscillator coil	122-066
Choke 100MH	122-004
Choke 1mH	122-065
Filter coil (19kHz phase)	122-080
Filter coil (SCA)	122-079

TRANSISTORS

Si. junction F.E.T.	132-049
Si. junction F.E.T.	132-049
Si. NPN transistor	132-015
Si. M.O.S. F.E.T.	132-064
Si. junction F.E.T.	132-049
Si. M.O.S. F.E.T.	132-064
Si. NPN transistor	132-041
Si. M.O.S. F.E.T.	132-061
Si. NPN transistor	132-057
Si. NPN transistor	132-052
Si. NPN transistor	132-057
Si. NPN transistor	132-057
Si. NPN transistor	132-042
Si. PNP transistor	132-056
Si. NPN transistor	132-041
Si. NPN transistor	132-052
Si. NPN transistor	132-072
Si. NPN transistor	132-041

POTENTIOMETERS

AM level control	134-177
Volume control	134-217
Muting control	134-216
FM level control	134-197
Separation adjust	134-212
Meter adjust	134-197

RESISTORS

R428	Wirewound 47 Ω 5W	139-045
R429	Wirewound 2 Ω 5W	139-005
R430	Wirewound 2.7 Ω 1W	139-002

SWITCHES

S1	Antenna selector	148-019
S2	AM sensitivity	148-023
S3	Mode selector	146-135
S301	Muting switch	146-136
S302	H.F. filter switch	146-136
S401	Dial scale intensity	148-023

TRANSFORMERS

T1	Balun	043-226
T2	FM IF transformer	162-042
T3	AM antenna matching trans.	162-043
T4	AM RF transformer	162-033
T101	FM discriminator	162-036
T201	AM IF transformer	162-038
T202	AM IF transformer	162-038
T203	AM IF transformer	162-038
T301	RF transformer (19kHz)	162-031
T302	RF transformer (38kHz)	162-039
T401	Power transformer	043-865

TUBES

V1	6HU6	165-025
----	------	---------

INTEGRATED CIRCUITS

IC1,2	Integrated circuit	133-002
-------	--------------------	---------

METERS

M1	Signal strength meter	124-005
M301	Tuning Meter	124-006

CRYSTAL FILTERS

XF-1	Crystal filter	044-045
XF-2	Crystal filter	044-045A

LAMPS

#1847 (meter lamp)	058-008
#1866 (front panel)	058-014
#1828 (MPX lamp)	058-027
Festoon lamp (dial glass)	058-032

FRONT PANEL & TRIM

Front panel	043-971
Front panel end caps	018-120
Tuning knob	043-272
Volume control knob	043-253
Mode selector knob	043-253
Muting knob	043-253

H.F. filter knob	043-253
Muting adj. knob	090-010

MOUNTING SYSTEM

Shelf bracket (right)	043-592
Shelf bracket (left)	043-593
Mounting template #100	038-179
Hardware package	043-446

MISCELLANEOUS ITEMS

FM dipole antenna	170-033
Dial glass	044-079
Pointer	043-876
Dial cord (complete)	043-891
Fuseholder	178-001
AC power cord	170-021
Shipping carton	043-988
Owners manual	038-448
Plastic feet	017-041
Push terminal (antenna)	074-032
Audio cable (6')	170-015
LDR network	144-013

McIntosh SERVICE BULLETIN

FM-RF AMPLIFIER MODIFICATION

MODEL: MR73 FM/AM Tuner

PURPOSE OF MODIFICATION: To decrease power dissipation in transistor Q2

WHAT UNITS ARE AFFECTED: Serial No. 10T01 to 27T84 Only.

WHEN MODIFICATION SHOULD BE MADE: When the customer complains that FM sensitivity has decreased or FM tuner has become noisy.

McINTOSH MODIFICATION KIT NO.: 044-175

PARTS REQUIRED: (Supplied in Kit)

QUANTITY	PART NUMBER	DESCRIPTION
1	132-049	FET transistor <i>USE 132-097 @</i>
1	136-396	220 Ω 10% 1/4W resistor

PROCEDURE: (Refer to the diagram on reverse side)

- Step 1 Remove bottom cover and bottom cover of RF front end.
- Step 2 Replace transistor Q2. Be sure leads are of same length and have same positioning as used on original transistor.
- Step 3 Counting from the front of the tuner, locate the fourth feed-thru capacitor on the left side of the RF front end. Remove the red lead and connect it to the unused second feed-thru capacitor. Remove the 220 Ω 10% 1/4W resistor (R2) connecting between feed-thru capacitors 3 and 4, and connect this resistor between feed-thru capacitors 2 and 3. Connect the new 220 Ω 10% 1/4W resistor (R21) between feed-thru capacitors 2 and 4.
- Step 4 Replace both covers.
- Step 5 Check performance of tuner. Perform alignment steps 6 and 7 as in Service Manual if necessary to meet performance specifications. To perform alignment remove the cover from the top of the RF front end.

(over)

FRONT OF UNIT

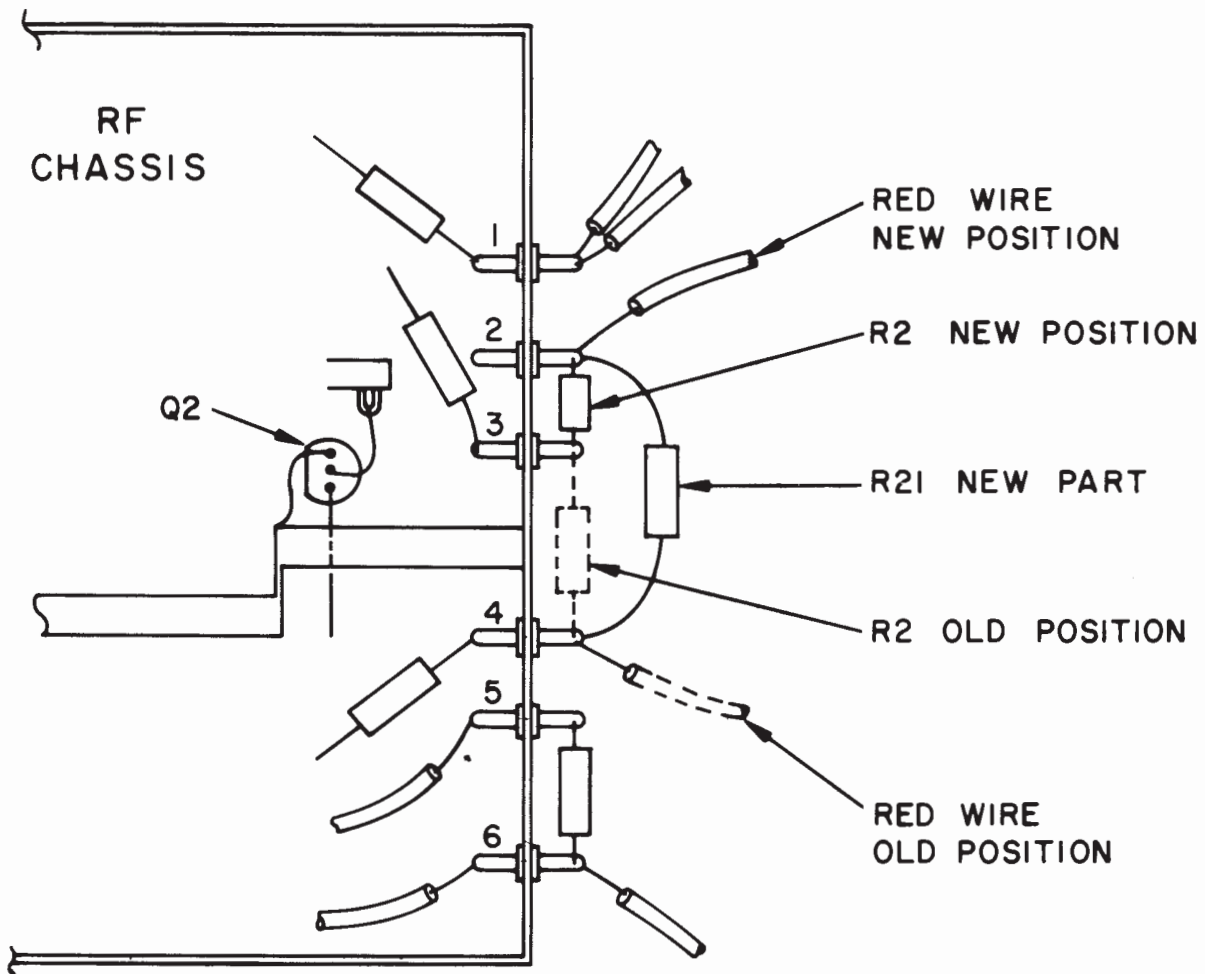

BOTTOM VIEW



SERVICE BULLETIN

MR 73
S.B. No. 2

AM NOISE REDUCTION MODIFICATION

MODEL: MR 73 FM/AM Tuner

PURPOSE OF MODIFICATION: To improve AM signal to noise ratio.

WHAT UNITS ARE AFFECTED: Serial No. 10T01 to 35T90 Only.

WHEN MODIFICATION SHOULD BE MADE: When customer complains that AM is noisy on local stations or that sensitivity is poor.

McINTOSH MODIFICATION KIT NO.: No kit.

PARTS REQUIRED:

QUANTITY	PART NUMBER	DESCRIPTION
1	061-043	.01 μ F +80-20% Disc capacitor

PROCEDURE:

- Step 1 Remove Multiplex-AM top and bottom covers. Remove capacitors C204 and C208 on AM PC board. See service manual for exact location.
- Step 2 Remove bottom cover of RF front end. Connect the .01 μ F disc capacitor across R17, a 270 Ω 1/4W resistor. (One end of R17 is connected to Q5). Replace covers.
- Step 3 Check performance. If dial calibration is off at high end of the band, perform AM alignment steps 3, 5, and 7 as in service manual. The top cover of the RF front end is removed for access to the alignment trimmers.

038-531