



MS300

MUSIC SERVER



CONTENTS

Performance Specifications	2	Interconnection Diagram	5
Notes	2	Front Panel Schematic and PCB	7 - 10
Safety Information	2	Exploded View and Parts List	11 - 12
Rear Panel	3	Parts List	15
Section Location	3	Repacking List	17
Block Diagram	4		

SERVICE MANUAL

PERFORMANCE SPECIFICATIONS

Specifications are subject to change without notice. Please check the McIntosh web site for any changes to the specifications.

Audio Specifications

Frequency Response: 2–20,000Hz, +/-1 dB
Signal to Noise Ratio: 102dB (IHF A-Weighted)
Dynamic Range: 96dB
Harmonic Distortion: 0.01%
Channel Separation: 95dB (1,000Hz)
Output Level: 2.0 Vrms
Output Impedance: 200 ohms

Video Specifications

Signal System: NTSC, PAL (Factory Option)
Output Impedance: 75 ohm

General Specifications

Digital Output Optical: -15dbm to -21dbm
Digital Output Coaxial: 0.4Vpp to 0.6Vpp/75 ohm
Digital Signal Format: 44.1kHz Sampling Frequency
Power Requirements: 100-240 Volts, 50-60Hz at 60 watts
Overall Dimensions: Width is 17-1/2 inches (44.45cm)
Height is 5-3/8 inches (13.69cm)
Depth is 15 inches (38.1cm)

Note: When the disc tray is Opened, the panel clearance required in front of mounting panel is 5-1/4 inches (13.3cm)

Weight: 20.7 pounds (9.4Kg) net, 37.2 pounds (16.9Kg) in shipping carton

NOTES

1. Unless otherwise noted, all voltages indicated on the schematics are measured under the following conditions:
 - a. AC input at 120 volts, 50/60Hz.
 - b. All voltages are +/-10% with respect to ground. A high impedance (10 megaohm) voltmeter must be used.
3. Unless otherwise specified:
 - a. Resistor values are in ohms.
 - b. Capacitor values are microfarads (uF).
 - c. Inductor values are in microhenries (uH)
4. On PC board drawings, Square pad indicates:
 - a. Polarized Capacitors - Positive
 - b. Diodes - Cathode
 - c. Others - Pin 1
5. **WARNING**
Parts marked with the symbol  have critical characteristics. Use only replacement parts recommended by the manufacturer.
6. Use McIntosh Remote Control Model HR053 with the MS300.
7. See Advanced Users Guide for Keyboard (050202) operation.

SAFETY INFORMATION

CAUTION: Invisible Laser Radiation when open. DO NOT stare into the beam or view directly with optical instruments. Use of controls or adjustments or performance of procedures other than those specified in the Owners Manual may result in Hazardous Radiation Exposure.

This product incorporates an embedded CLASS 3B Laser (IEC60825-1).



COMPLIES WITH DHHS RULES
21 CFR 1040.10 AND 1040.11

CAUTION: CLASS 3B INVISIBLE
LASER RADIATION WHEN OPEN.
AVOID EXPOSURE TO THE BEAM.

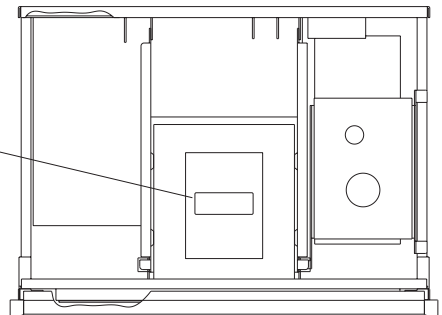

REAR PANEL

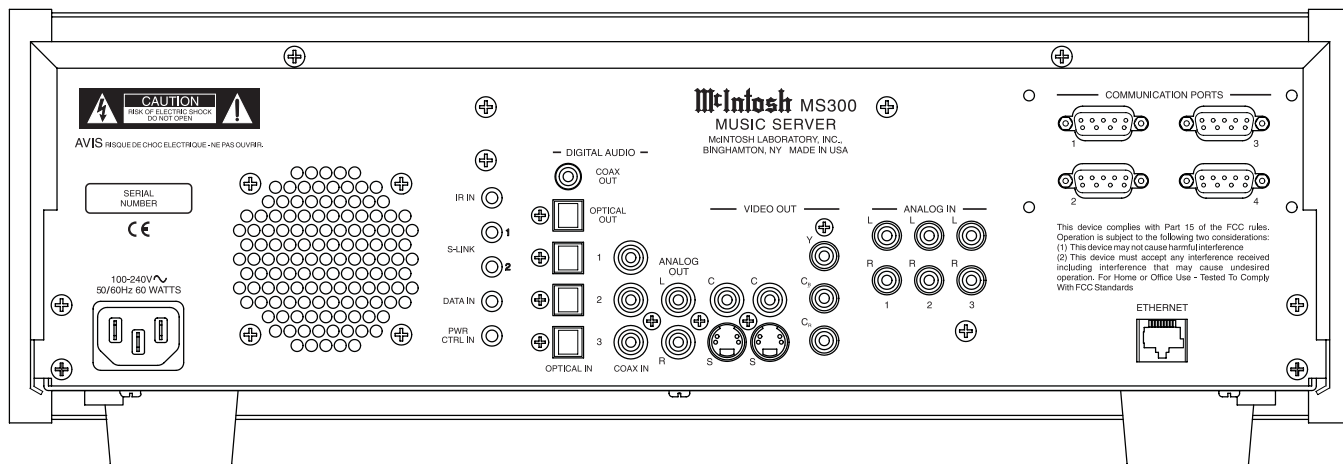

SECTION LOCATIONS

TOP VIEW WITH COVER REMOVED

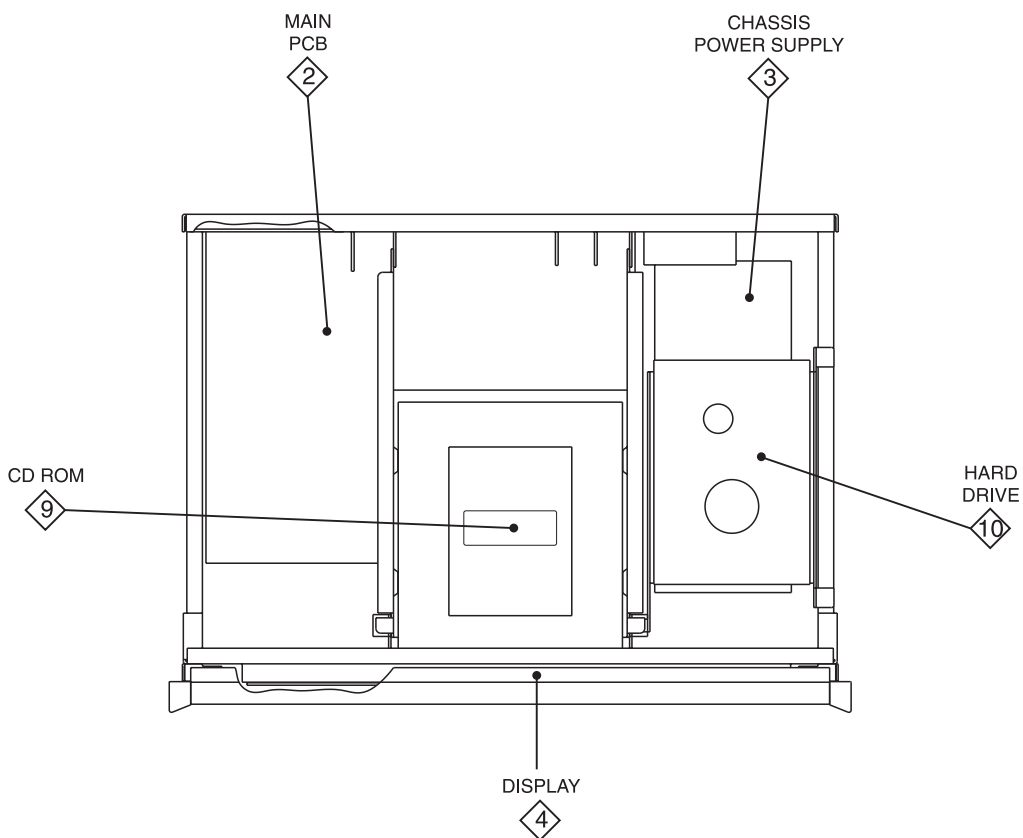

NOTES

1

INTERCONNECT

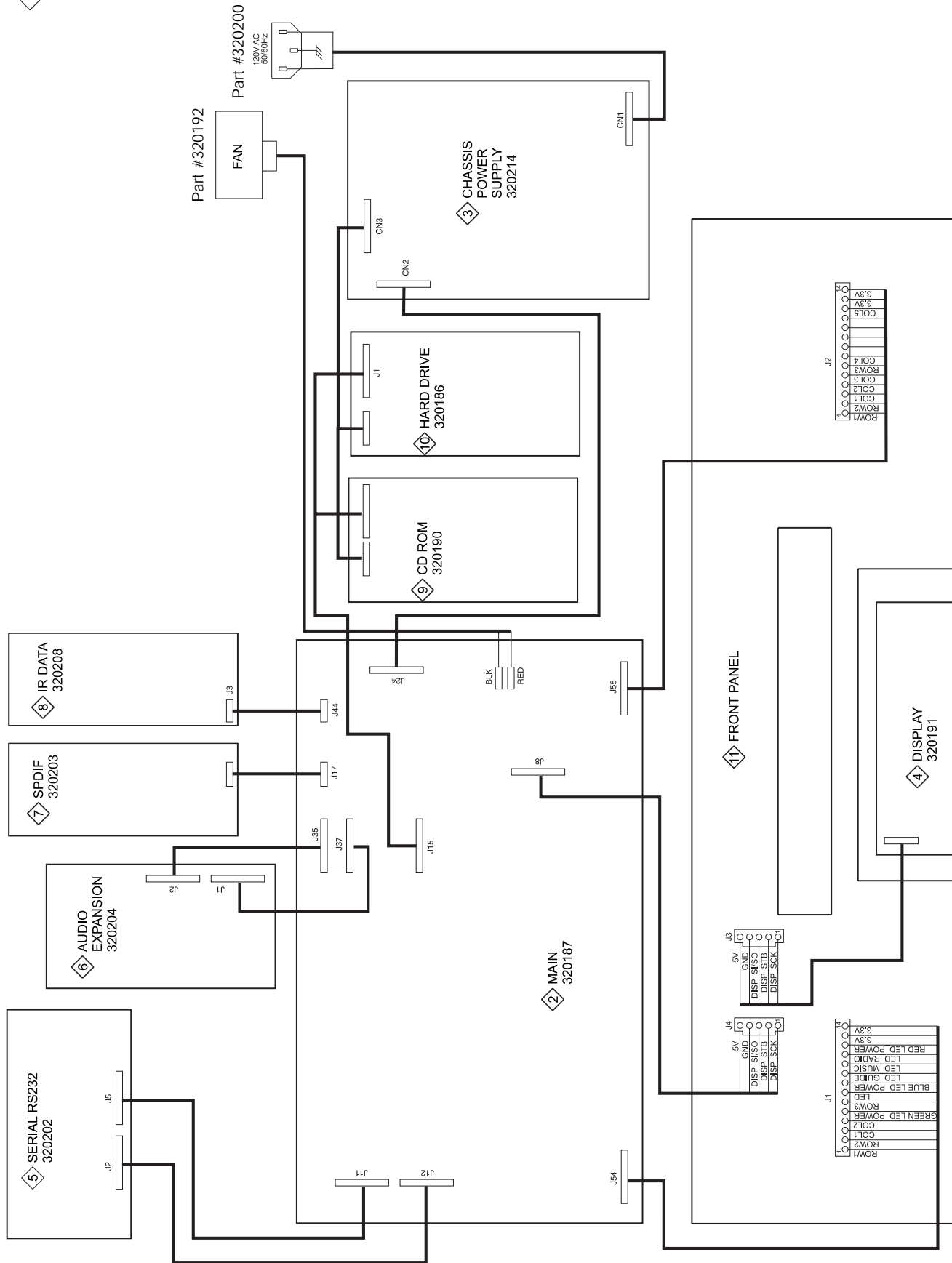

NOTES

11 FRONT PANEL 050177

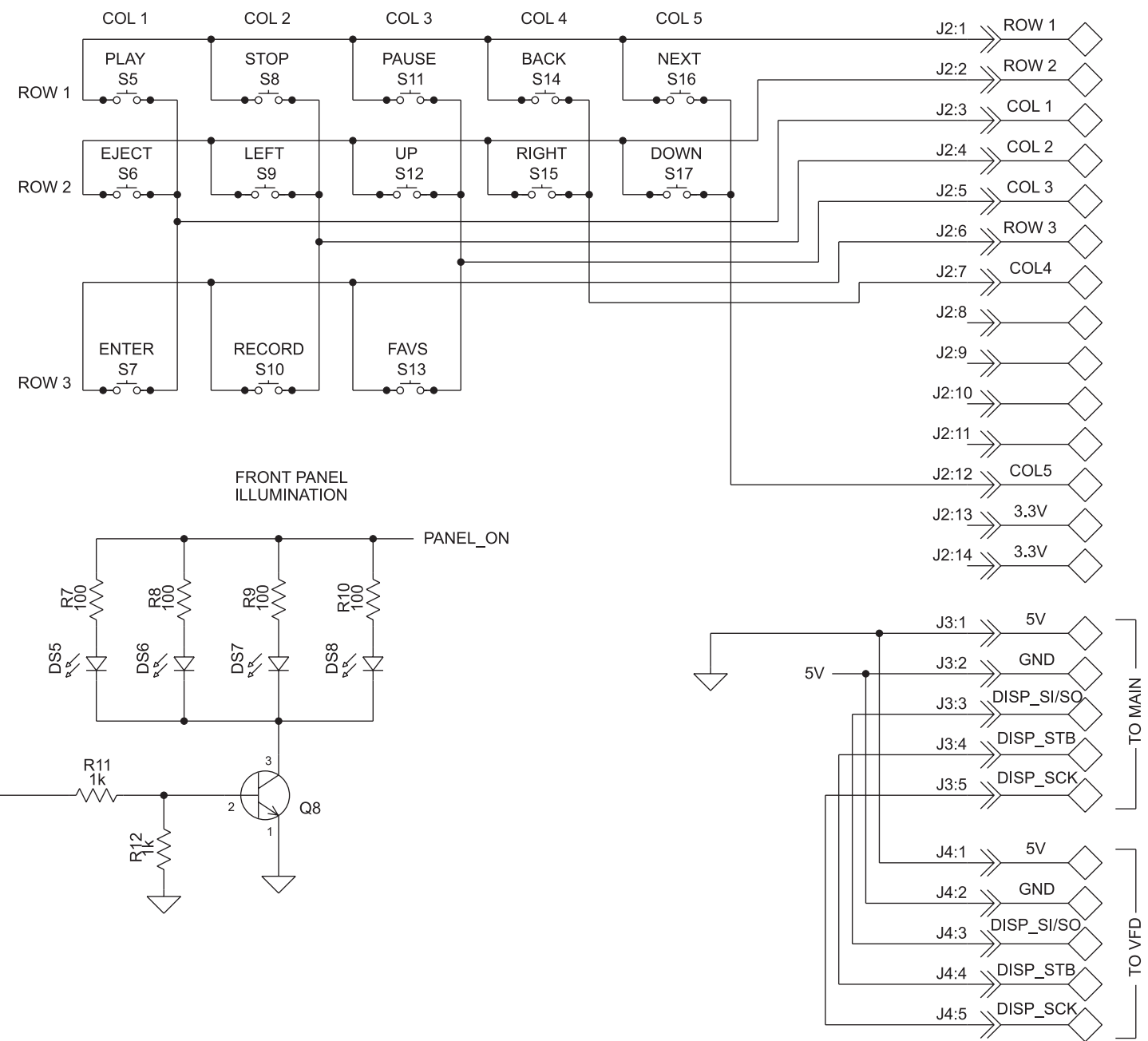
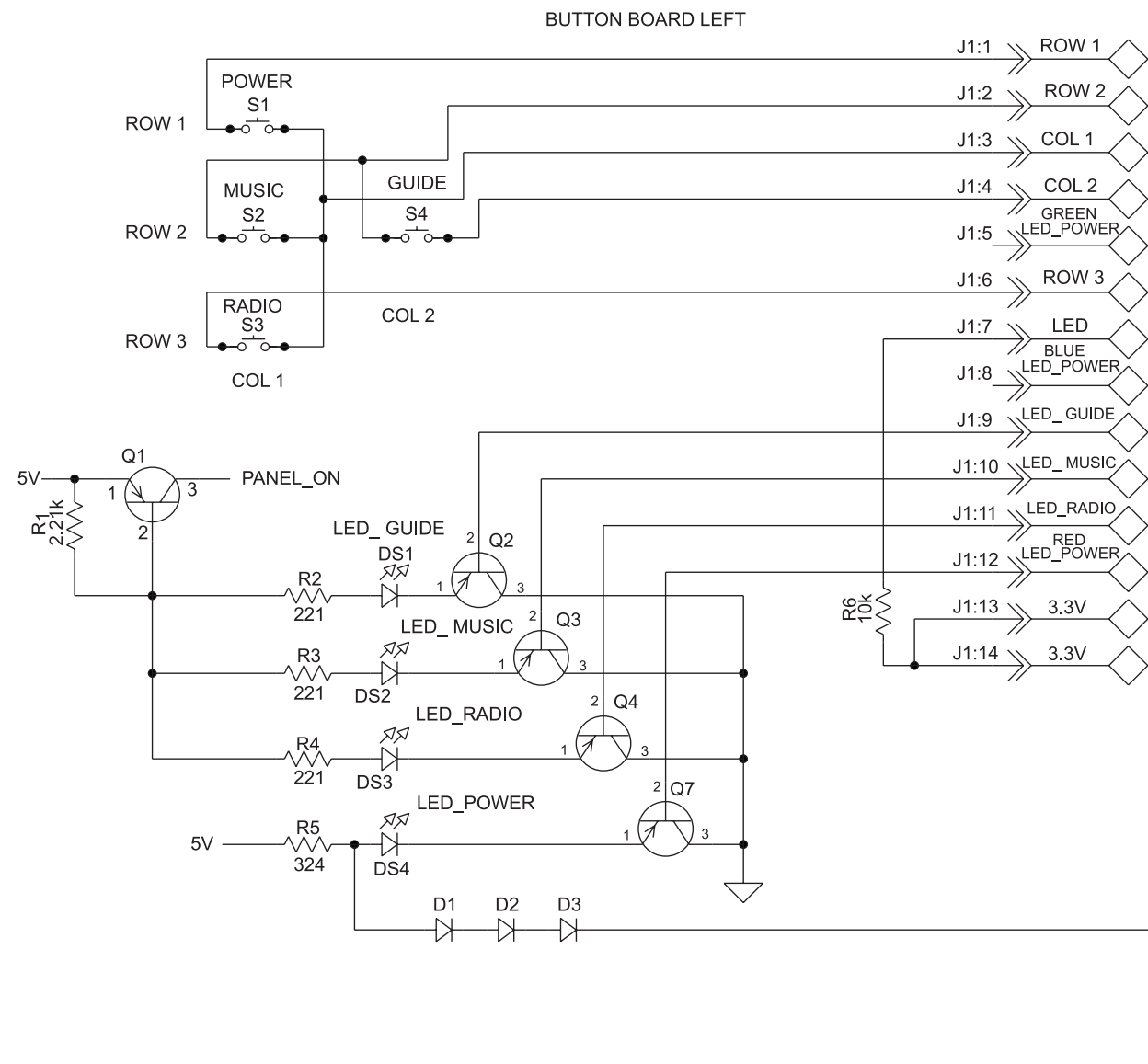

11 FRONT PANEL 050177

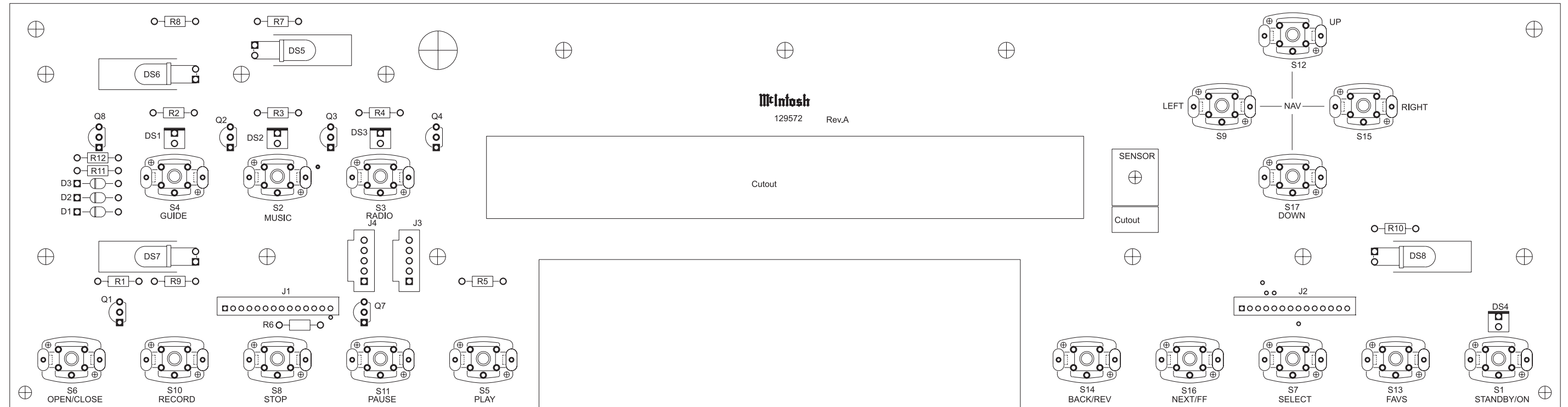

EXPLODED VIEW AND PARTS LIST

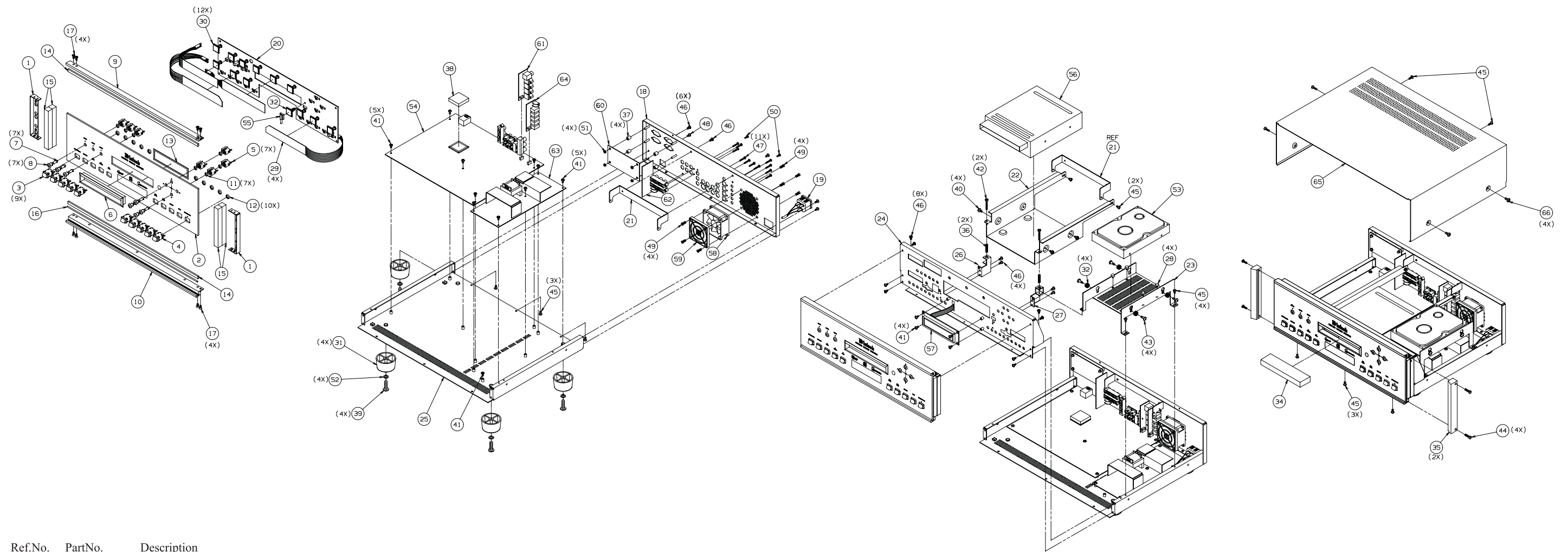

Ref.No.	PartNo.	Description	Ref.No.	PartNo.	Description	Ref.No.	PartNo.	Description
1	005090	BRACKET EXTRUSION	18	005496	FAB REAR PANEL	35	018611	ENDCAP 5IN
2	016514	FAB GLASS PANEL	19	320200	CABLE ASSY POWER INLET	36	019056	SPRING
3	017517	PUSHBUTTON ASSY	20	050177	ASSY PCB FRONT PANEL	37	021092	SPACER: 6 X 5/16
4	017741	PUSHBUTTON ASSY RED	21	005491	FAB REAR CD TRAY MOUNT	38	076022	FERRITE SHIELD W/ADHESIVE
5	017781	RECEPTACLE PUSHBUTTON	22	005493	FAB CD TRAY	39	100159	SCREW MACH 10-32 X 3/4 PH PN BLK
6	017781	BEZEL FRONT	23	005494	FAB HD TRAY	40	100211	SCREW MACH M3 X 6MM PHL PN BLK
7	017852	PUSHBUTTON BLACK	24	005495	FAB SUBPANEL	41	100250	SCREW MACH SEMS 6-32 X 1/4 PH PN
8	017938	PUSHBUTTON BEZEL	25	005497	FAB CHASSIS	42	100300	SCREW MACH SEMS 6-32 X 1 PH PAN
9	018585	EXTRUSION MATERIAL, GLASS	26	005503	FAB FRONT LEFT CD TRAY MOUNT	43	100362	SCREW 6-32 SHOULDER HD MOUNT
10	018706	EXTRUSION BOTTOM	27	005504	FAB FRONT RIGHT CD TRAY MOUNT	44	101042	SCREW TS 4-40 X 1/2 SLOT FLLSTR
11	078032	O-RING	28	017862	FOOT PUSH-ON	45	101054	SCREW TAPTT 6-32 X 1/4 PH PN BLK
12	078033	O-RING	29	017901	LOGO PUSHBUTTON BACKLIGHT	46	101196	SCREW TAP SEMS 6-32 X 1/4 PH PAN
13	092419	FILTER DISPLAY	30	017902	SUPPORT PCB LOCKING ADHSV BASE	47	101197	SCREW HI/LO 4-24 X 3/8 PH RD BLK
14	094016	TAPE FOAM 1/4 X 1/8IN	31	017937	FOOT	48	101222	SCREW TT SEMS 6-32 X 1/4 PH PAN
15	094360	TAPE FOAM 1/2 X 1/2IN	32	017981	VIBRATION ISOLATOR HARD DR	49	101240	SCREW FAN MOUNT BLACK
16	098113	CORD DIAL .027 BLACK BRAID SLK	33	017982	SUPPORT PCB LOCKING .250 MINI	50	101249	SCREW TAPTT M3 X 8MM PH PAN BLK
17	100147	SCREW MACH 6-32 X 3/16 PHIL	34	017983	MOLDING DOOR MS300	51	102045	NUT KEP 6-32 SPECIAL
						52	104083	WASHER #10 PLATED
						53	320186	HDD 300G 7200RPM FED MAXTOR
						54	320187	E2-MOTHERBOARD ASSEMBLY
						55	320188	CABLE ASSY IR RECEIVER
						56	320190	CDRW 52X12X52X
						57	320191	DISPLAY VFDCM 2 X 20 SERIAL
						58	320192	FAN 60MM X 60MM 12VDC BRUSHLESS
						59	320193	FANGUARD 60 X 60 PLASTIC
						60	320202	SERIAL BOARD RS232
						61	320203	SPDIF BOARD
						62	320204	AUDIO EXPANSION BOARD
						63	320214	POWER SUPPLY 75W
						64	320208	ASSY PCB SLINK
						65	005102	TOP COVER
						66	101078	SCREW TAP 8-32 X 5/16 PH PN BLK

NOTES

PARTS LIST

- ② **320187 MAIN PCB**
- ③ **320189 CHASSIS/POWER SUPPLY PCB**
See Note
- ④ **320191 DISPLAY PCB**
See Note
- ⑤ **320202 SERIAL RS232 PCB**
See Note
- ⑥ **320204 AUDIO EXPANSION PCB**
See Note
- ⑦ **320203 SPDIF PCB**
See Note
- ⑧ **320208 IR DATA PCB**
See Note
- ⑨ **320190 CD ROM PCB**
See Note
- ⑩ **320186 HARD DRIVE**
See Note

- ⑪ **050177 FRONT PANEL PCB**
- D1 DIODE SILICON 070047
- D2 DIODE SILICON 070047
- D3 DIODE SILICON 070047
- DS1 LED SQUARE RED 058109
- DS2 LED SQUARE RED 058109
- DS3 LED SQUARE RED 058109
- DS4 LED SQUARE RED 058109
- DS5 LED GREEN 5MM HI-INT 058165
- DS6 LED GREEN 5MM HI-INT 058165
- DS7 LED GREEN 5MM HI-INT 058165
- DS8 LED GREEN 5MM HI-INT 058165
- J1 CONN HEADER SHROUDED 1X14 117875
- J2 CONN HEADER SHROUDED 1X14 117875
- J3 CONN HEADER 1X5 STRAIGHT 117874
- J4 CONN HEADER 1X5 STRAIGHT 117874
- Q1 TRANSISTOR PNP SILICON 132172
- Q2 TRANSISTOR PNP 132224
- Q3 TRANSISTOR PNP 132224
- Q4 TRANSISTOR PNP 132224
- Q7 TRANSISTOR PNP 132224
- Q8 TRANSISTOR NPN 132223
- R1 RES MF 2.21K 1% 1/4W 144298
- R2 RES MF 221 OHM 1% 1/4W 144172
- R3 RES MF 221 OHM 1% 1/4W 144172
- R4 RES MF 221 OHM 1% 1/4W 144172
- R5 RES MF 324 OHM 1% 1/4W 144338
- R6 RES MF 10K 1% 1/4W 144053

- R7 RES MF 100 OHM 1% 1/4W 144196
- R8 RES MF 100 OHM 1% 1/4W 144196
- R9 RES MF 100 OHM 1% 1/4W 144196
- R10 RES MF 100 OHM 1% 1/4W 144196
- R11 RES MF 1K 1% 1/4W 144090
- R12 RES MF 1K 1% 1/4W 144090
- S1 SWITCH PB TACT 150058
- S2 SWITCH PB TACT 150059
- S3 SWITCH PB TACT 150059
- S4 SWITCH PB TACT 150059
- S5 SWITCH PB TACT 150058
- S6 SWITCH PB TACT 150058
- S7 SWITCH PB TACT 150058
- S8 SWITCH PB TACT 150058
- S9 SWITCH PB TACT 150059
- S10 SWITCH PB TACT 150058
- S11 SWITCH PB TACT 150058
- S12 SWITCH PB TACT 150059
- S13 SWITCH PB TACT 150058
- S14 SWITCH PB TACT 150058
- S15 SWITCH PB TACT 150059
- S16 SWITCH PB TACT 150058
- S17 SWITCH PB TACT 150059

NOTE:
Modules not available as replacement parts. If defect is suspected in these modules, contact factory for service options.

NOTES

REPACKING INSTRUCTIONS

In the event it is necessary to repack the unit for shipment, the unit must be packed exactly as shown below.

IMPORTANT - The four plastic feet must be attached to the bottom of the unit so they will locate in the four holes of the bottom pad. Failure to do this will result in shipping damage.

If a shipping carton or any of the interior parts is needed, please call or write the Customer Service Department of McIntosh Laboratory. Order parts from the accompanying list by part number.

Use the original shipping carton and interior parts only if they are in good serviceable condition.

Qty.	Part No.	Description
1	033838	Shipping carton only
4	033837	Foam end cap
1	033836	Inside carton only
1	033725	Top pad
1	034301	Bottom pad
4	017937	Plastic foot
4	100159	#10-32 x 3/4" Machine screw
4	104080	#10 x 7/16" Flat washer

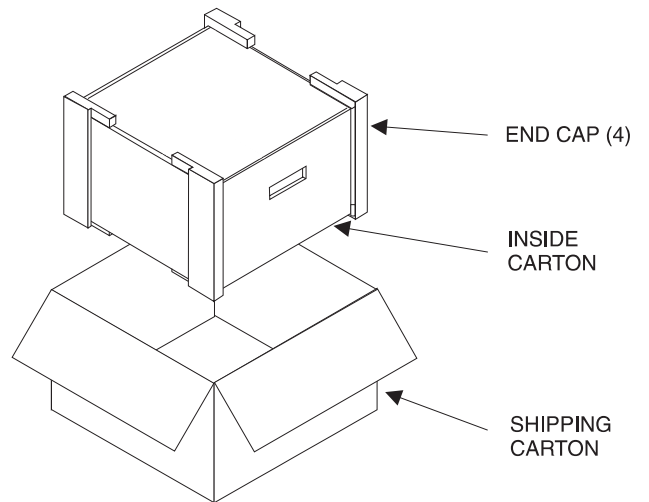
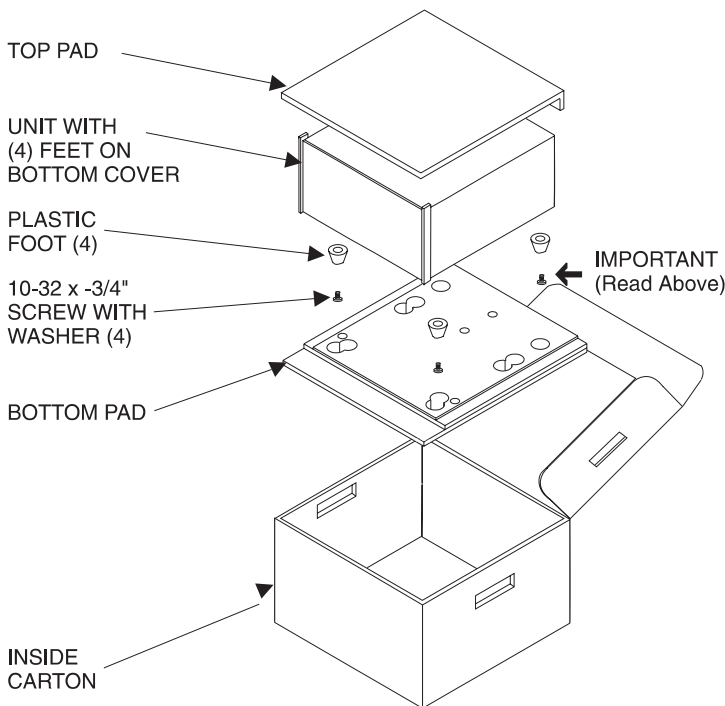

MS300

MUSIC SERVER

SERVICE MANUAL



The continuous improvement of its products is the policy of McIntosh Laboratory Incorporated, who reserve the right to improve design without notice. Because of the constant upgrading of McIntosh products' circuitry and components, the Company cannot insure, and does not warrant, the accuracy of the within schematic material, which is intended for information only.

McINTOSH LABORATORY, INC., 2 CHAMBERS STREET, BINGHAMTON, NEW YORK 13903 Printed in U.S.A. Part Number 040XXX