

# MICRO SEIKI®

DIRECT DRIVE TURNTABLE SYSTEM  
**DD-40**  
SERVICE MANUAL



 **MICRO SEIKI CO., LTD.**  
TOKYO JAPAN

Distributed in U.S.A. by  
TEAC CORPORATION OF AMERICA 7733 Telegraph Road, Montebello, Ca. 90640

Printed in JAPAN

# CONTENTS

1. PARTS NOMENCLATURE .....	1
2. REPLACEMENT	
TONEARM REPLACEMENT .....	2
MOTOR REPLACEMENT .....	2
POWER SUPPLY CIRCUIT BOARD REPLACEMENT .....	2
POWER SWITCH REPLACEMENT .....	2
SPEED SELECTION SWITCH & VARIABLE RESISTOR REPLACEMENT .....	3
3. ADJUSTMENTS	
OVER HANG ADJUSTMENT .....	4
HEADSHELL TILT ADJUSTMENT .....	4
LATERAL BALANCING ADJUSTMENT .....	4
ANTI-SKATING ADJUSTMENT .....	4
ARM LIFTER ADJUSTMENT .....	5
TONEARM HEIGHT ADJUSTMENT .....	5
FINE SPEED ADJUSTMENT FOR TURNTABLE SPEEDS .....	5
DUST COVER HINGES ADJUSTMENT .....	5
4. POWER SUPPLY CIRCUIT Ass'y .....	6
NEON LAMP CIRCUIT Ass'y .....	6
5. POWER SUPPLY CIRCUIT DIAGRAM .....	7
6. EXPLODED VIEW .....	8
PARTS LIST FOR EXPLODED VIEW .....	9
7. EXPLODED VIEW (TONEARM) .....	10
PARTS LIST FOR EXPLODED VIEW .....	11
8. PACKING FOR SHIPMENT .....	12
9. SPECIFICATIONS .....	13

# PARTS NOMENCLATURE

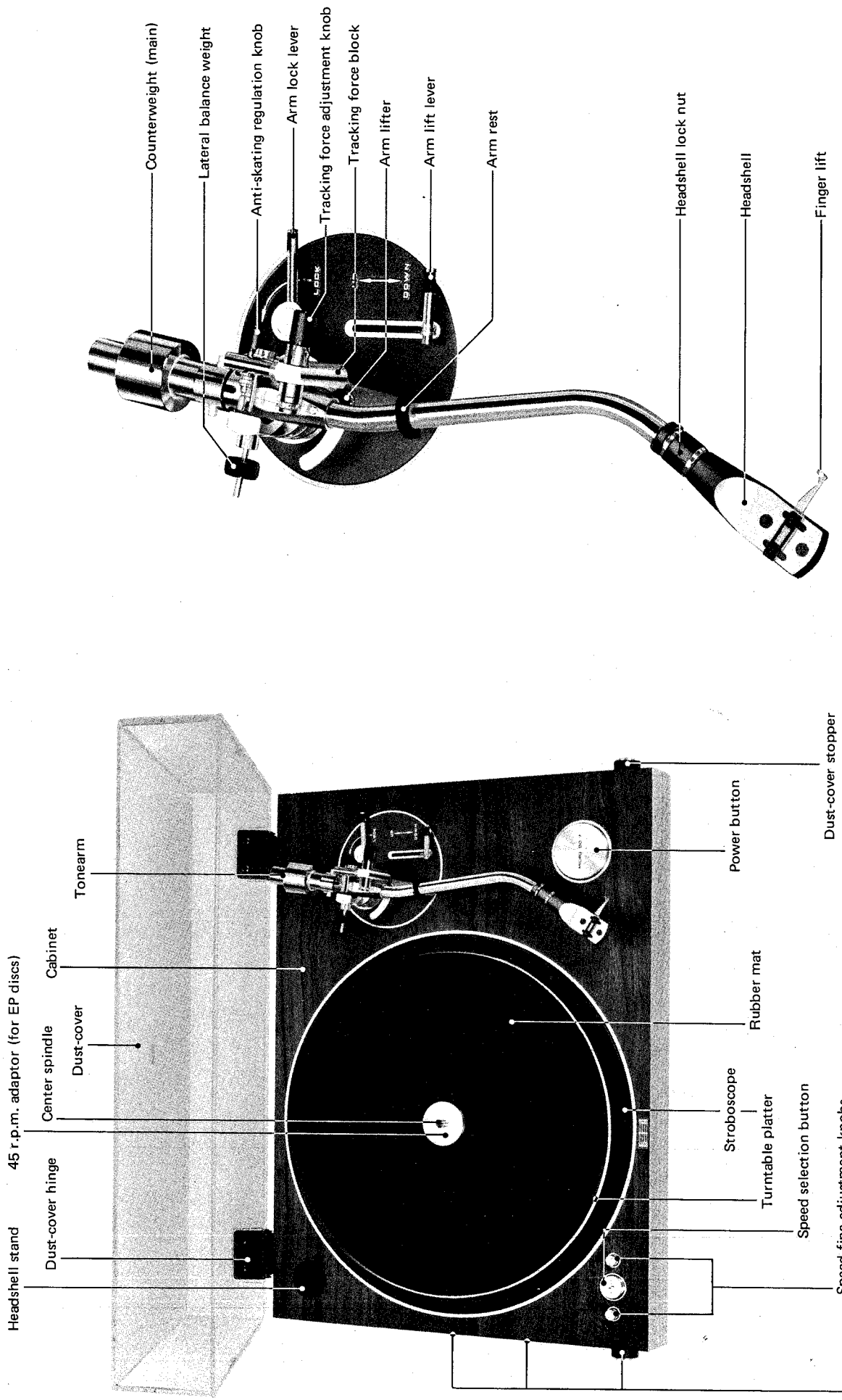

Sub-arm base installation nuts  
(3 locations of which 1 also functions as the dust-cover stopper)

Photo 1

Photo 2

# REPLACEMENT

## ● TONEARM REPLACEMENT

- 1) Remove the turntable platter.
- 2) Remove the 3 screws at the bottom of the wooden base.

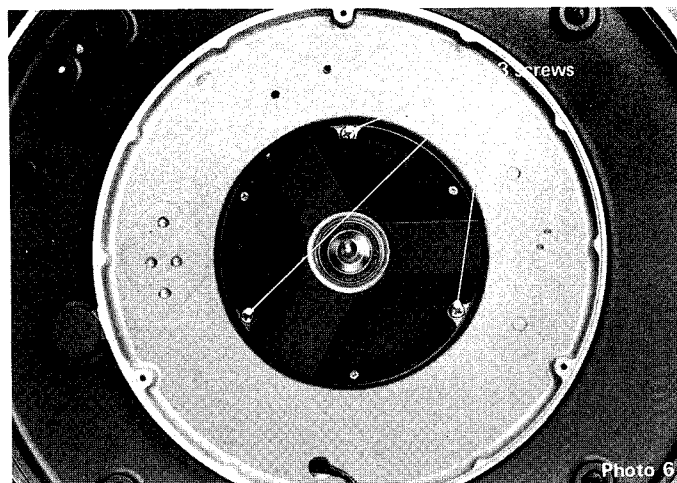
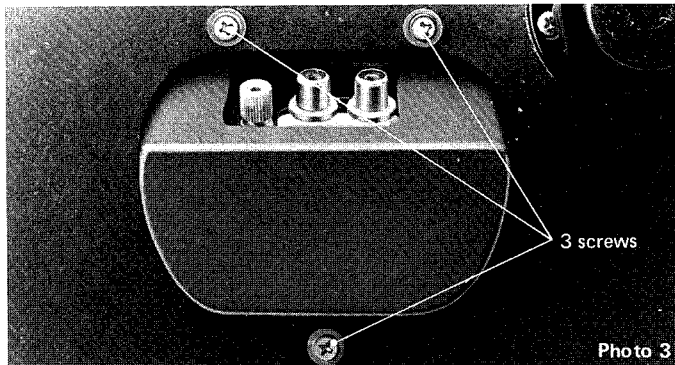

## ● MOTOR REPLACEMENT

- 1) Remove the 3 screws retaining the bottom cover to the main panel.

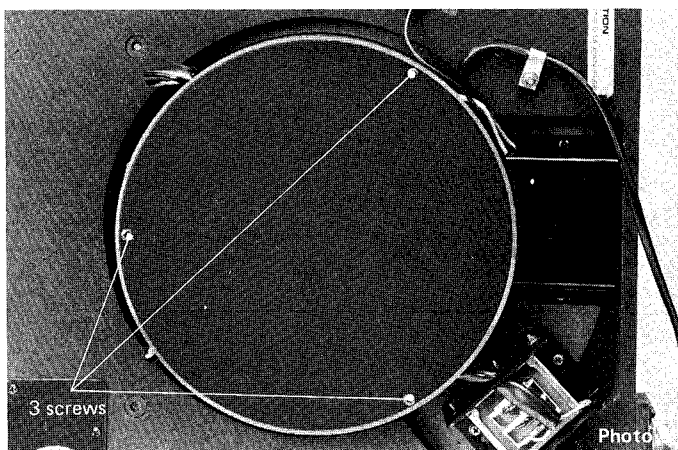

- 2) Unsolder the lead wires from the power supply circuit board and the terminal lug.
- 3) Remove the 3 screws retaining the motor cover to the main panel.

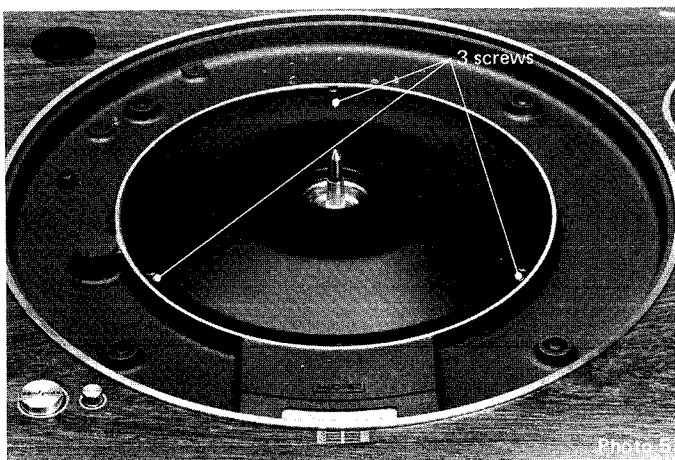

- 4) Remove the 3 screws securing the motor to the main panel.

## ● POWER SUPPLY CIRCUIT BOARD REPLACEMENT

- 1) Remove the 3 screws retaining the bottom cover to the main panel.
- 2) Unsolder the lead wires from the circuit board.
- 3) Remove the 2 screws retaining the circuit board to the main panel.

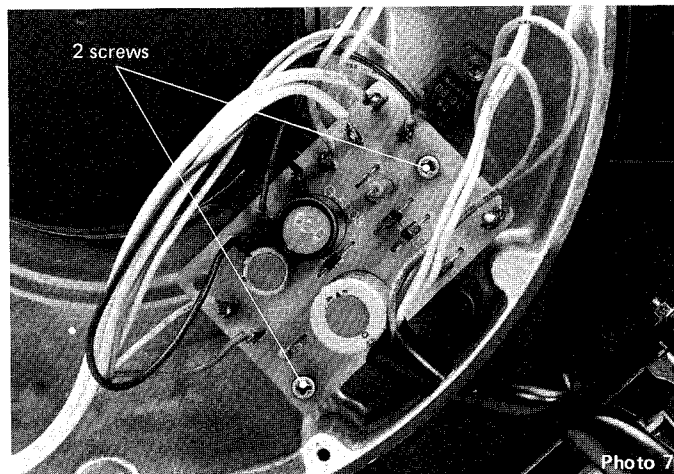

## ● POWER SWITCH REPLACEMENT

- 1) Remove the height adjustor of the rubber foot.

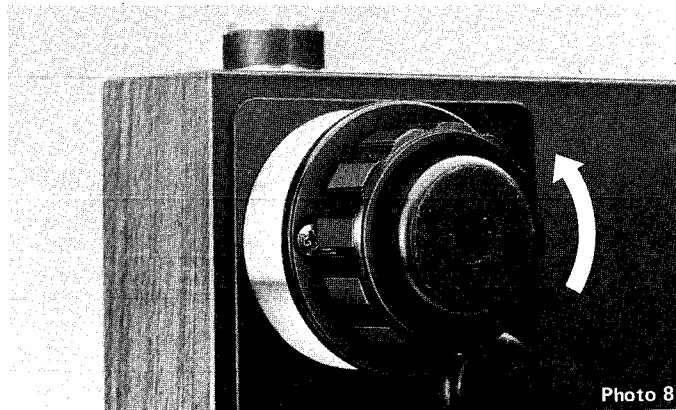

- 2) Remove the 3 screws retaining the foot base to the wooden base and the power switch cover.

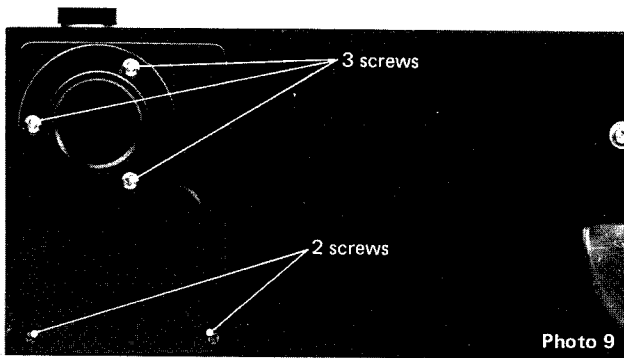

Photo 9

- 3) Remove the 2 screws retaining the cover to the wooden base.
- 4) To remove the power button, insert the screwdriver in to the center hole of the power switch bracket and push up.

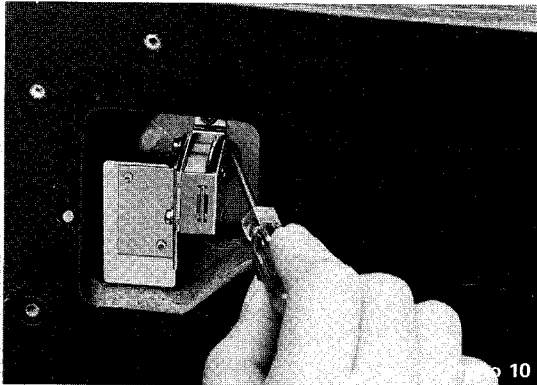

Photo 10

- 5) Remove the 2 screws retaining the power switch mechanism ass'y to the bracket.

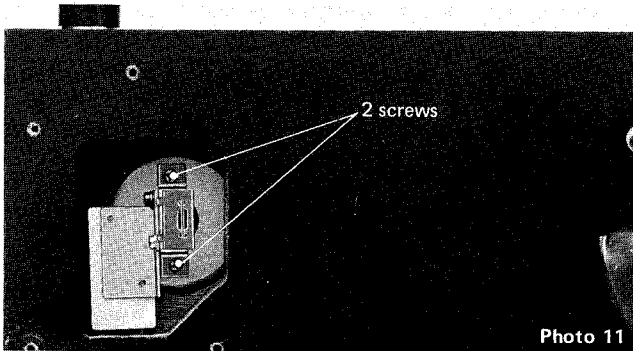

Photo 11

- 6) Unsolder the lead wires from the micro switch.
- 7) Remove the 2 polycarbonate screws retaining the micro switch to the assembly.

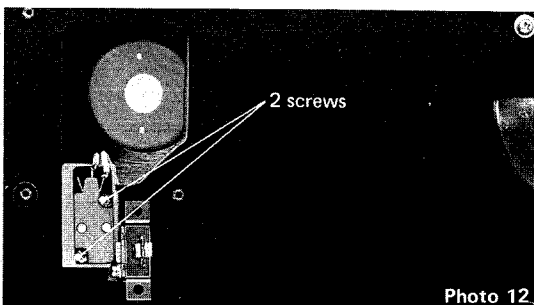

Photo 12

## • SPEED SELECTION SWITCH & VARIABLE RESISTOR REPLACEMENT

- 1) Remove the height adjustor of the rubber foot.

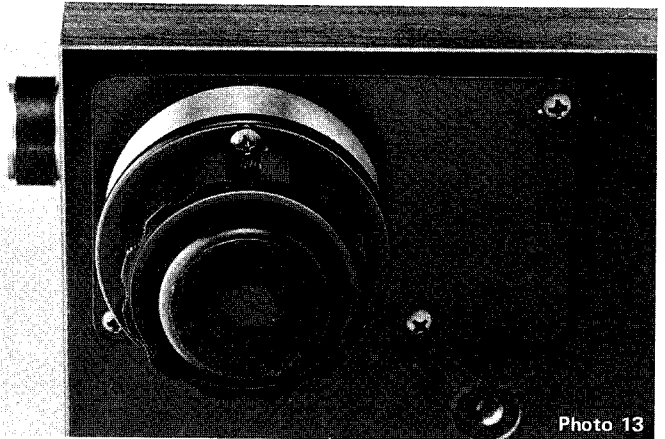

Photo 13

- 2) Remove the 3 screws retaining the foot base to the wooden base and the selection switch cover.
- 3) Remove the 3 screws retaining the cover to the wooden base.

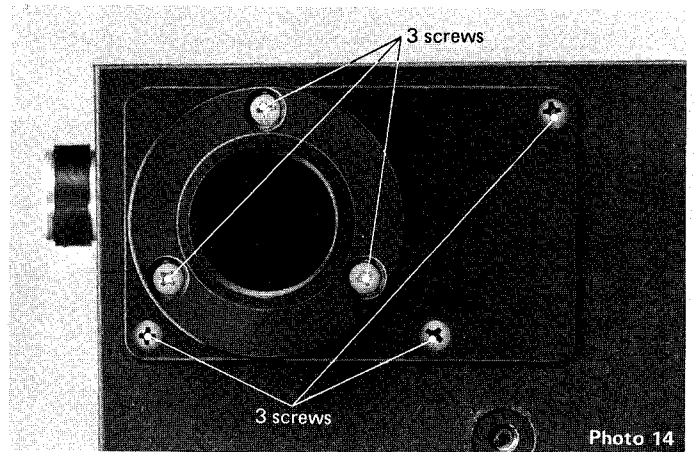

Photo 14

- 4) Unsolder the lead wires from the selection switch or variable resistor.
- 5) Remove the 3 screws retaining the selection switch bracket to the wooden base.

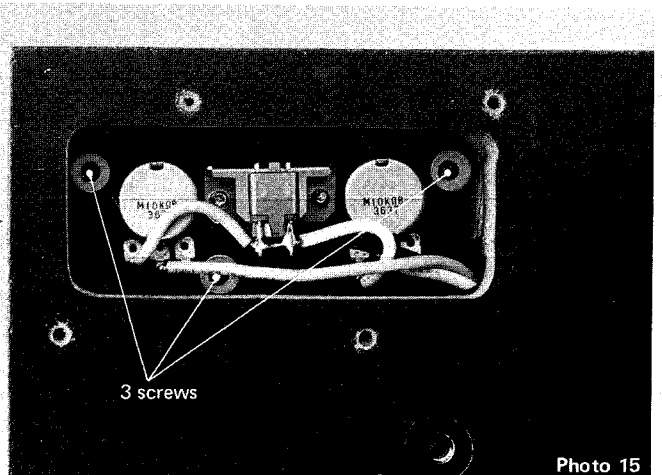

Photo 15

# ADJUSTMENTS

- Overhang adjustment

Overhang is the distance between the center of the platter spindle and the stylus tip. The DD-40 is designed to operate with minimal tracking error when the overhang is adjusted to 15 mm. In order to adjust the cartridge correctly, place the enclosed overhang gauge over the headsheel as shown in photo 5.

Loosen the cartridge securing screws and align the stylus to the ▼ marks on the gauge by moving the cartridge either forward or backward. When a different cartridge is installed in the headshell, be sure to re-adjust, using the method described above.

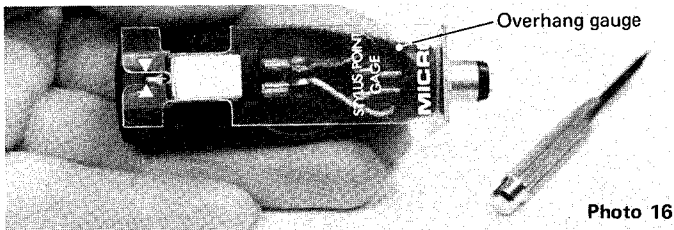

Photo 16

- Headshell Tilt Adjustment

If there is headshell tilt after shell change-over, remedy this condition by loosening the clamp screw and correcting the faulty tilt as shown in Photo 17.

Caution: Do not adjust or tamper with this screw unless it is necessary.

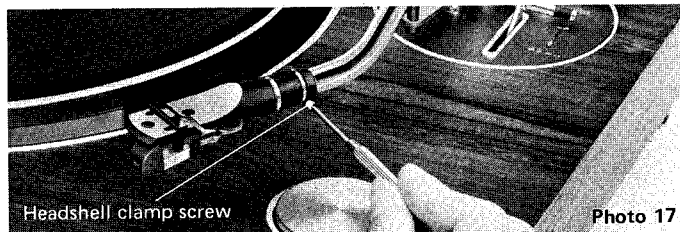

Photo 17

- LATERAL BALANCING ADJUSTMENT

- 1) Turn the tracking force adjustment knob to set the tracking force level to zero.
- 2) Turn the counterweight to achieve the tonearm balance.
- 3) Plug the large lateral balance weight on to the lateral shaft.

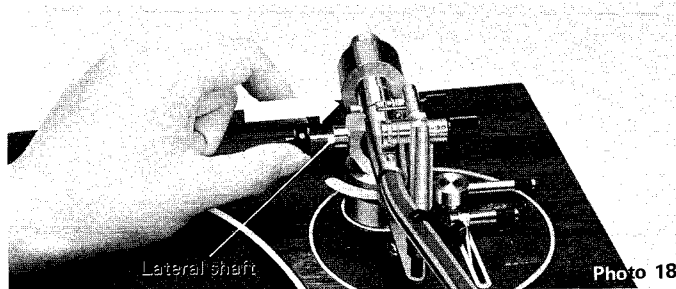

Photo 18

- 4) Raise the rear of the turntable and observe the direction in which the tonearm travels. Slide the lateral balance weight along the shaft in the same direction until the tonearm stop moving.

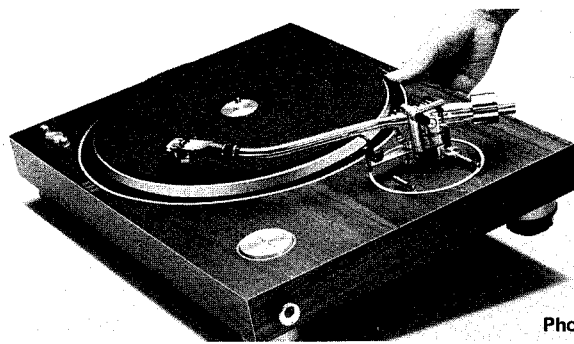

Photo 19

- 5) Tighten the lock screws to secure the lateral balance weight.

Note:

- (1) In a case such as that shown in Fig. 1 when the lateral balance weight has been set at the extreme end of the lateral shaft, and yet the tonearm continues to travel in the direction shown by arrow A, correct by using both the large and the small lateral weights.
- (2) In a case such as that shown in Fig. 1 when the large lateral balance weight has been set at the innermost point on the lateral shaft, and yet the tonearm continues to travel in the direction shown by arrow B, change to the small balance weight and re-adjust.

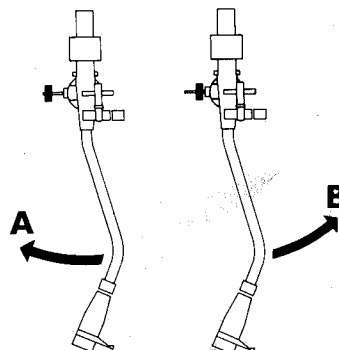

Fig. 1

- Anti-skating Adjustment

The DD-40 anti-skating device can be regulated to conform with stylus tip configurations. When the cartridge to be used has an elliptical stylus, turn the anti-skating regulation knob until the red line on the shaft is aligned with that inscribed on the wire guide (see Photo 20 and Fig. 2). With a spherical stylus align the blue line on the shaft to that on the wire guide. Set this way, corresponding outside force is added, rendering regulation unnecessary even when the tracking force is changed.

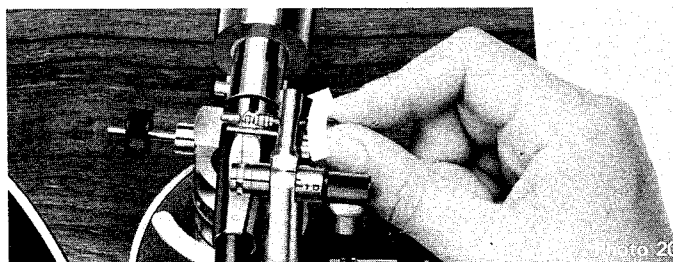

Photo 20

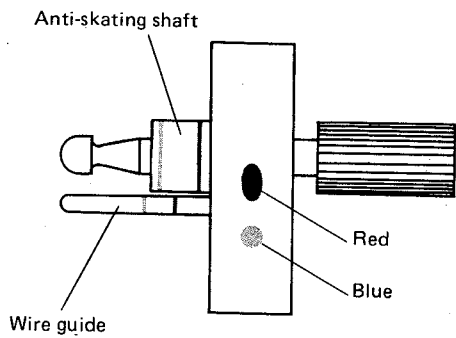

Fig. 2

● **Arm Lifting Adjustment**

The optimum distance between the stylus tip and the record surface is approximately 1 cm. Raise the arm lift lever and move the tonearm to a point above the record surface. Determine whether the distance between the stylus and the record surface is adequate. If necessary, regulate the adjusting screw as illustrated in Photo 21.

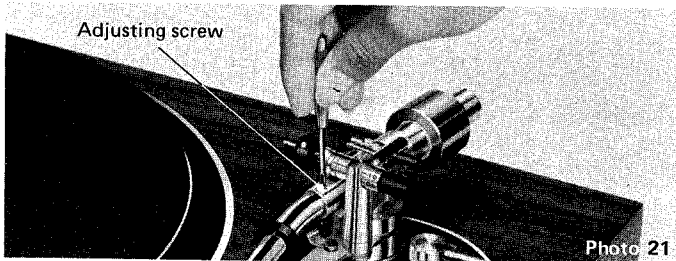

Photo 21

In case where an adjustment cannot be completed by means of the adjusting screw only, loosen the lifter mechanism height adjustment screw and re-adjust the height of the arm lift (see Photo 22).

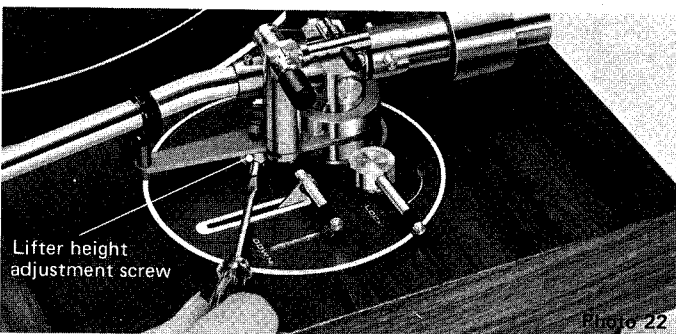

Photo 22

● **Tonearm Height Adjustment**

It is necessary to adjust the tonearm height (in conformity with the height of the cartridge being used) until it lies on a plane parallel to the record surface.

Place a record on the turntable and lower the arm lift lever. Then, watching from the right-hand side of the unit, release the arm lock lever and observe if the tonearm adopts a parallel position. (When the lock is released, the tonearm will rise to the furthest point permitted by its spring.) If the required adjustment still exceeds the height obtained by the spring, further adjust by gently pulling up the base cap. (Photo 23)

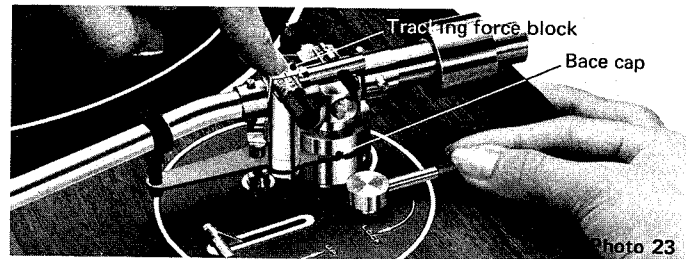

Photo 23

● **FINE SPEED ADJUSTMENT FOR TURNTABLE SPEEDS**

When adjustment of the speed fine adjustment knob does not give a satisfactory speed, adjust the motor in accordance with the following procedure.

- 1) Remove the 3 screws retaining the bottom cover to the main panel.
- 2) Set the speed fine adjustment knobs to the middle position.
- 3) While watching the stroboscope stripes on the turntable platter, adjust the variable resistor inside the motor for appropriate static display of the strobe.

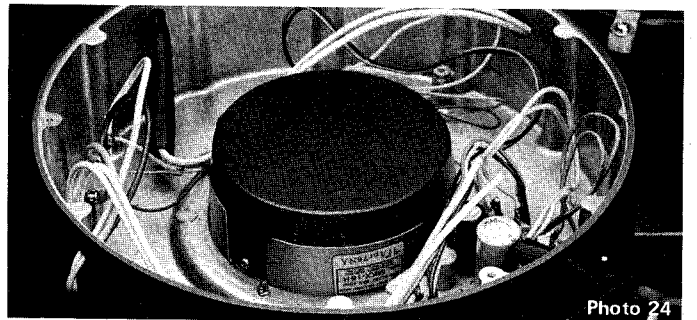

Photo 24

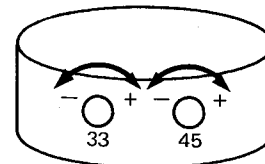

Fig. 3

- 4) Alternate switching between 33 and 45 rpm speeds while making adjustment. Make sure that both speeds are correct.

● **DUST COVER HINGES ADJUSTMENT**

The tension of the dust cover hinges can be adjusted by turning the screws on the back of the hinges.

1. Counter clockwise: More tension
2. Clockwise : Less tension

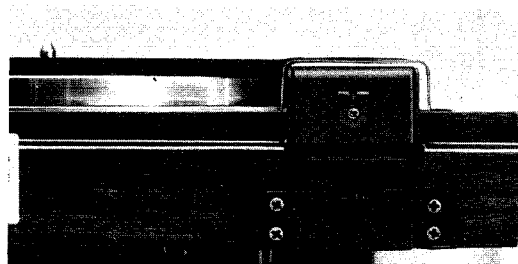
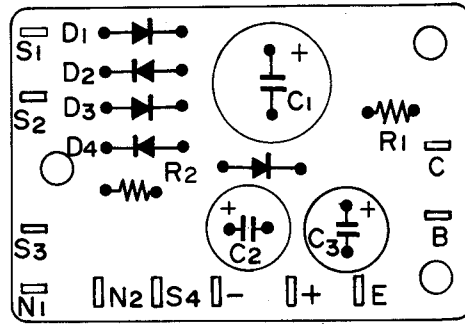

Photo 25



# POWER SUPPLY CIRCUIT ASS'Y

(TOP VIEW)



CIRCUIT REF. No.	PARTS No.	DESCRIPTION
D1~ D4	00063-06	F-14A
ZD1	00064-00	WZ-240
C1	00066-00	470 $\mu$ / 35V
C2	00067-04	100 $\mu$ / 25V
C3	00068-09	220 $\mu$ / 35V
R1	00069-03	3.3K $\frac{1}{4}$ W
R2	00070-06	33K $\frac{1}{2}$ W

# NEON LAMP CIRCUIT ASS'Y

(TOP VIEW)

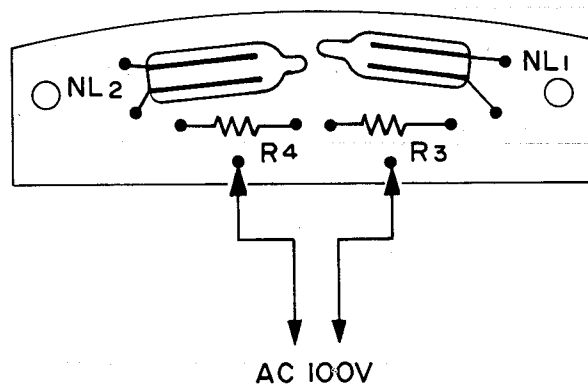

CIRCUIT REF. No.	PARTS No.	DESCRIPTION
R3.R4	00058-05	15K $\frac{1}{4}$ W
NL1 .NL2	00057-00	NL-13



# POWER SUPPLY CIRCUIT DIAGRAM

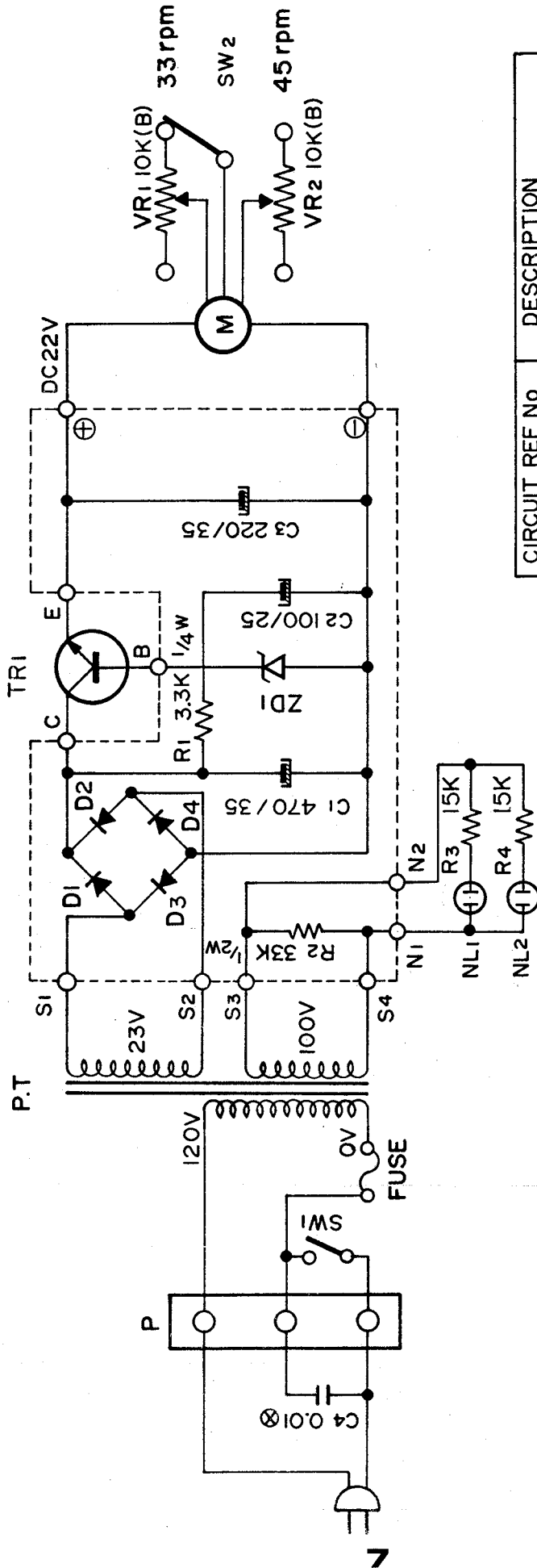

CIRCUIT REF No	DESCRIPTION
TRI	2SD313, 2SD325
D1~D4	F-14A
ZD1	WZ-240
NL1,NL2	NL-13
FUSE	0.5A $\phi$ 6x23L
P.T	POWER TRANSFORMER
P	TERMINAL 3P

# EXPLODED VIEW

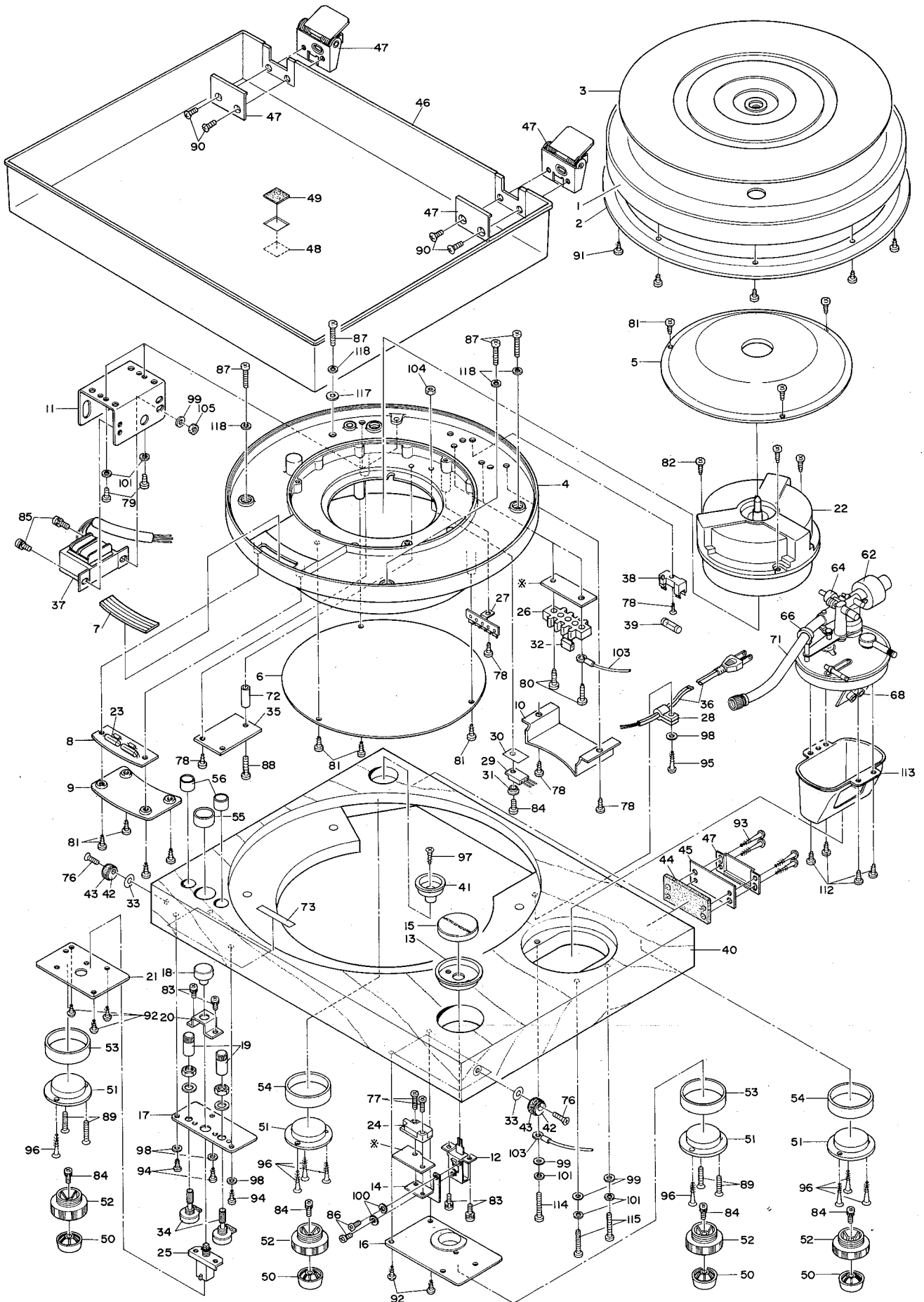

# PARTS LIST FOR EXPLODED VIEW

## TURNTABLE

REF. NO.	PARTS NO.	DESCRIPTION	REF. NO.	PARTS NO.	DESCRIPTION
1	20584-03	Turntable Platter	59	90008-05	Screwdriver
2	30728-27	Stroboscope Ring	60	41610-06	Stylus Brush
3	43931-20	Rubber Mat	61		Headshell Ass'y
4	10221-56	Main Panel	62	43921-06	Main Weight
5	44135-08	Motor Cover	63	43922-16	Sub-weight
6	43951-28	Bottom Cover	64	44086-13	Lateral Weight (A)
7	44436-16	Strobe Mask	65	44087-18	Lateral Weight (B)
8	43862-23	Neon Tube Cover	66	42821-01	Tonearm Rest
9	4386-24	Neon Tube Circuit Board	67	43962-20	Lifter Blade
10	44414-10	Terminal Cover	68	43912-12	Output Terminal Ass'y
11	30853-07	Transformer Holder	69	43910-34	Terminal Holder
12		Power Switch Mechanism Ass'y	70	30729-37	Output Cord
13	44160-06	Power Switch Bracket	71		Tonearm Ass'y
14	43831-12	Switch Holder	72	60064-06	Spacer $\phi$ x17 $\bar{l}$
15	44431-08	Power Button	73	44040-11	Strobe Label
16	43833-32	Power Switch Cover	774	60094-07	Flat Head Screw M2.6x10
17	43851-10	Change-over Switch Bracket	75	60095-01	Flat Head Screw M2.6x14
18	43942-13	Switch Button Ass'y	76	60046-08	Countersunk Head Screw M5x20
19	43826-27	Control Knob	77		Pan Head Tapping Screw 3x15
20	44047-29	Button Guide	78	60065-00	Pan Head Tapping Screw 3x8
21	43834-21	Change-over Switch Cover	79	60066-05	Pan Head Tapping Screw 4x8
22	00062-01	Motor KMX-15F	80	60067-00	Pan Head Tapping Screw 4x15
23	00057-00	Neon Tube, NL-13	81	60047-02	Binding-head Tapping Screw 3x8 B
24	00075-09	Micro Switch, AM-47009	82	60048-07	Pan Head Tapping Screw 4x16
25		Push Switch, SVE-12	83		Pan Head Screw M3x5
26	00080-00	Terminal 3P	84		Pan Head Screw M3x8
27	00074-04	Terminal Lug type 1L4P	85		Pan Head Screw M4x10
28	50032-00	Cord Holder	86	60049-01	Pan Head Screw M3x3
29	00065-05	Transistor 2SD313	87	60051-09	Pan Head Screw M5x30 B
30	50051-08	Insulator Sheet	88	60068-04	Pan Head Screw M3x25
31	50050-03	Bushing Sanyo M90-02	89	60052-08	Oval Countersunk Head Screw M3x25
32	00071-00	X-Type Capacitor 0.01 $\mu$ F	90	60052-08	Oval Countersunk Head Screw M4x10 B
33	44140-14	Washer $\phi$ 14	91		Binding Head Screw M3x8 B
34	00060-02	Variable Resistor 10 k $\Omega$ (B)	92	60055-07	Oval Head Wood Screw $\phi$ 3.1x10 B
35	44244-05	Power Supply Circuit Board	93	60057-01	Oval Head Wood Screw $\phi$ 3.1x32 B
36	00081-04	AC Cord	94	60057-06	Oval Head Wood Screw $\phi$ 2.7x10
37	30866-04	Power Transformer	95	60072-00	Oval Head Wood Screw $\phi$ 3.1x16
38	00078-02	Fuse Holder X-N 1157	96	60072-00	Oval Head Wood Screw $\phi$ 3.1x16
39	00077-08	Fuse 0.5A	97	60074-00	Countersunk Head Wood Screw $\phi$ 3.1x10 B
40	10255-13	Wooden Base	98	60074-00	Washer $\phi$ 3x $\phi$ 8x0.8t
41	43969-28	Headshell Stand	99	60119-03	Washer $\phi$ 4x $\phi$ 10x1t
42	43842-10	Dust Cover Stopper	100	60060-08	Spring Washer M3
43	43843-15	Rubber Ring	101		Spring Washer M4
44	43847-34	Hinge Base	102	60039-08	Oval Lug M3
45	43848-23	Hinge Plate	103	60062-07	Oval Lug M3
46	20475-01	Dust Cover	104	60027-05	Nut M3
47		Lock Plate & Spring Hinge Ass'y	105	60119-03	Nut M3
48	44136-02	Name Plate (Outside)	106	60096-06	Flat Head Screw M3.6x18 B
49	42634-03	Name Plate (Inside)	107	44430-03	Carton Box
50	42888-05	Rubber Foot Ass'y 50 $^{\circ}$	108		Side Packing (R & L)
51	43507-31	Foot Base	109		Parts Container
52	42177-08	Height Adjustor	110		Parts Container Cover
53	43852-09	Foot Base Ring (S)	111	44168-02	Top Packing
54	43936-18	Foot Base Ring (L) (20)	112		Pan Head Tapping Screw M3x5
55	43837-25	Decoration Ring (L)	113		Tonearm Base Cover
56	43838-20	Decoration Ring (S)	114		Pan Head Screw M4x40
57	43850-15	Record Adaptor 45 rpm	115		Pan Head Screw M4x35
58	42890-02	Overhang Gauge	116		Cover Sheet

# EXPLODED VIEW (TONEARM)

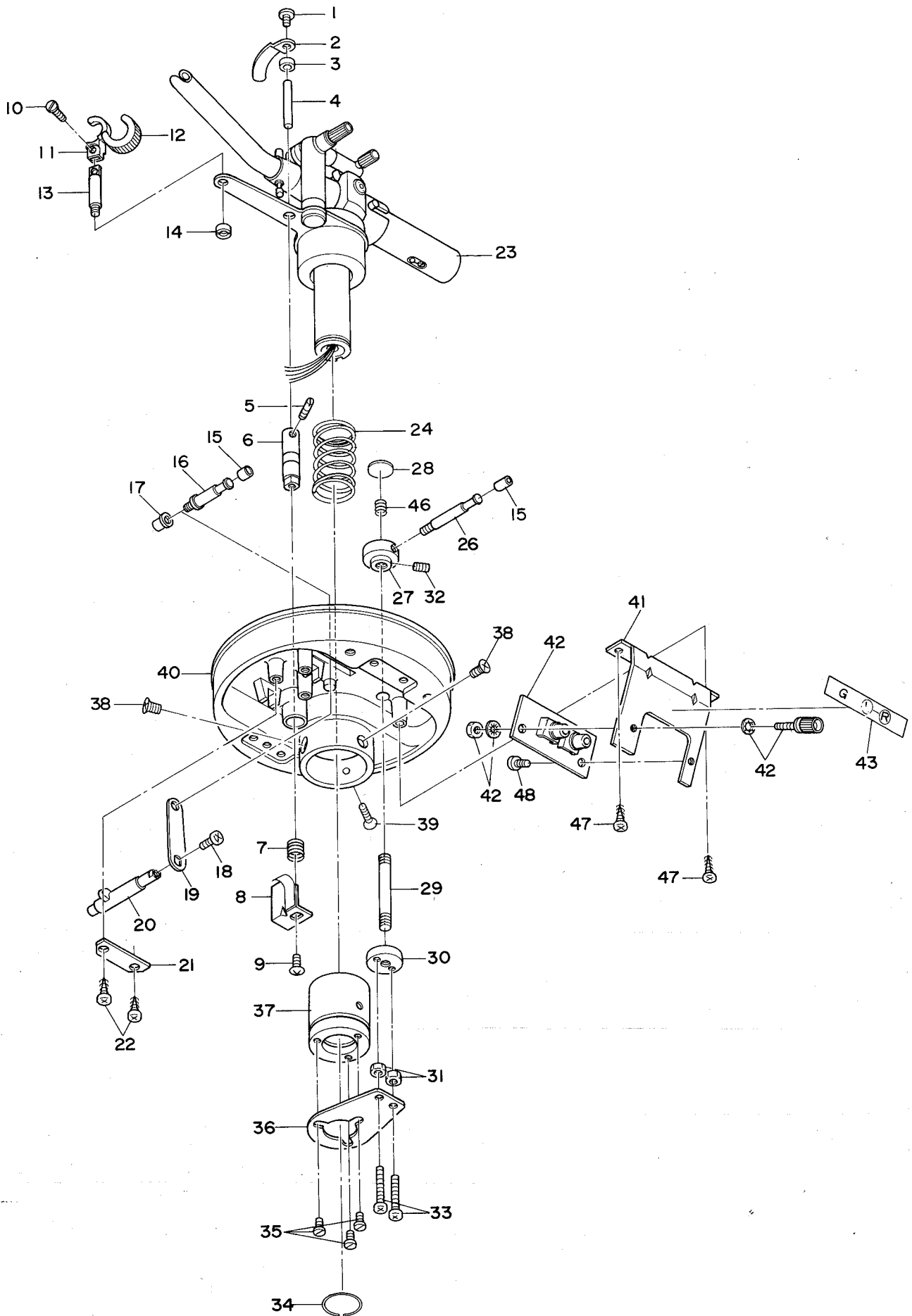

# PARTS LIST FOR EXPLODED VIEW

## TONARM ASS'Y

REF. NO.	PARTS NO.	DESCRIPTION	REF. NO.	PARTS NO.	DESCRIPTION
1	43864-22	Set Screw	41	43910-34	Terminal Holder
2	43926-20	Lifter Plate	42	43912-12	Output Terminal Ass'y
3	43925-04	Lifter Plate Base	43	43956-15	Label
4	43927-24	Lifter Plate Shaft	44		
5	43953-11	Set Screw	45		
6	43928-29	Lifter Shaft	46	60105-01	Set Screw M6x6
7	43934-24	Lifter Spring	47	60081-00	Tapping Screw M3x5
8	43934-24	Actuating Plate	48	40084-03	Pan Head Screw M3x3
9	60090-09	Truss Screw M3x5	49		
10	60079-02	Screw M2.6x4	50		
11	42821-02	Tonearm Rest			
12	42822-01	Tonearm Locker			
13	43949-41	Tonearm Rest Holder			
14	43950-23	Lock Nut			
15	43862-12	Rubber Tube			
16	43916-15	Lifter Handle			
17	43915-16	Lock Screw			
18	60083-09	Binder Tapping Screw M2.6.6			
19	43914-27	Lifter Lever			
20	43932-30	Cam Shaft			
21	43466-36	Cam Shaft Keeper			
22	60087-07	Tapping Screw M2.6x5			
23	44130-26	Main Sleeve			
24	44063-12	Spring			
25					
26	43919-14	Lock Handle			
27	43917-15	Lock Handle Hub			
28	40830-07	Decoration Cap			
29	44846-05	Lock Shaft			
30	44001-11	Lock Plate Lifter			
31	60109-00	M3 Nut			
32	60104-07	Set Screw M2x4			
33	60088-01	Pan Head Screw M3x18			
34	44013-09	Main Sleeve Stopper			
35	60080-05	Flat Fillister Head Screw M2.3x5			
36	44000-22	Lock Plate			
37	44035-26	Lock Sleeve			
38	60107-00	Countersunk Head Screw M2.6x6			
39	60106-06	Countersunk Head Screw M2.6x8			
40	20485-05	Tonearm Base			

# PACKING FOR SHIPMENT

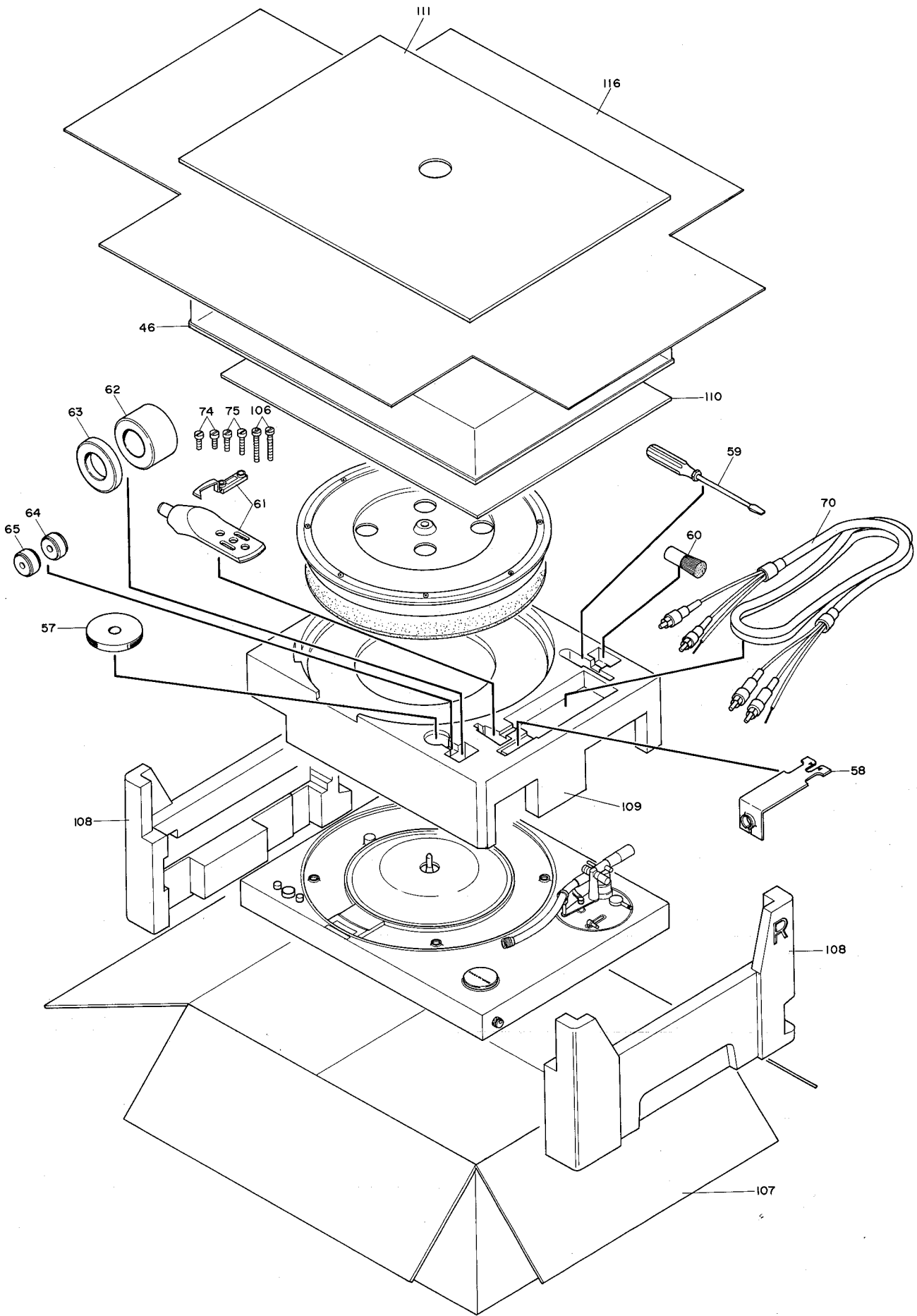

# SPECIFICATIONS

## MOTOR

Drive system .....	Direct drive with DC servo motor
Speeds .....	33-1/3, 45 rpm
Fine speed adjustment range .....	±6%
Turntable platter .....	Die-cast aluminum 32 cm (12-5/8 In) 1.5 kg (3.3 lbs)
Wow & flutter .....	Less than 0.028%
Power .....	U.S.A. & Canada 117V 60Hz other areas 220-240V 50Hz 16.5W

## TONEARM

Type .....	Dynamic balance
Effective length .....	237 mm (9-5/16 in)
Overhang .....	15 mm (9-16 in)
Offset angle .....	21°
Maximum tracking error .....	Less than 1.5°
Range of stylus tracking force adjustment .....	0-3 g
Dimensions .....	(W) 497 x (D) 385 x (H) 154 mm (19-9/16 x 15-5/32 x 6-1/16 in)
Weight .....	11.5 kg (25.4 lbs)



