

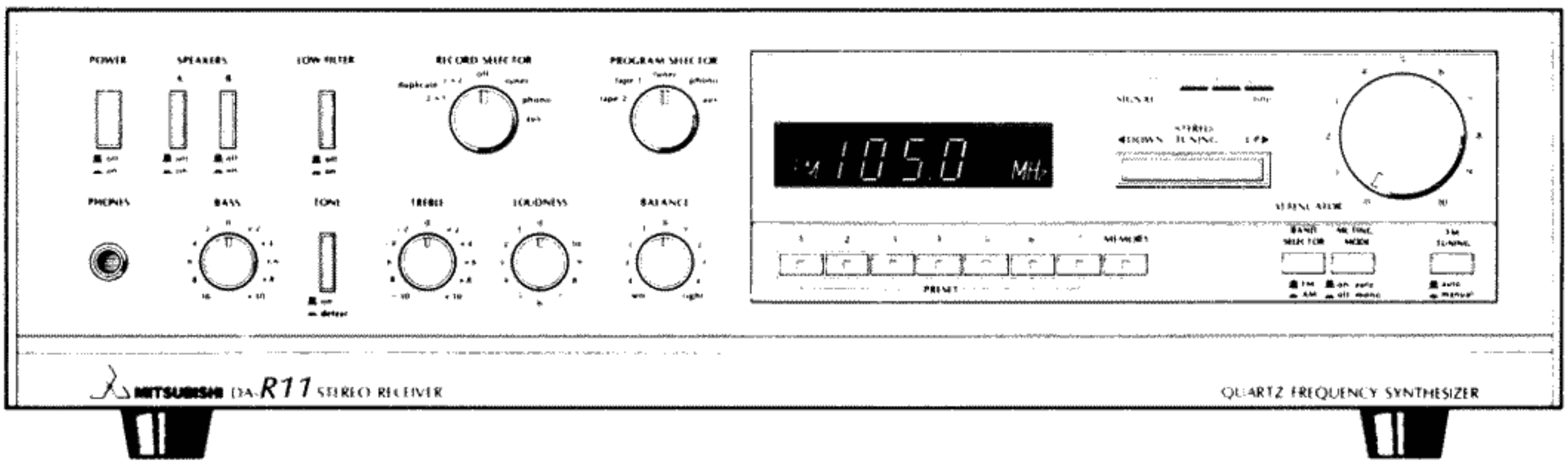

SERVICE MANUAL  
**STEREO RECEIVER**  
 MODEL DA-R11



**CONTENTS**

SPECIFICATIONS .....	2
FRONT PANEL TERMINOLOGY AND FUNCTIONS .....	3
DISASSEMBLY INSTRUCTIONS .....	5
FM ADJUSTMENT .....	6
AM ADJUSTMENT .....	6
INTERNAL DIAGRAMS AND PINOUT OF INTEGRATED CIRCUIT .....	7
WIRING DIAGRAM .....	9
SCHEMATIC DIAGRAM .....	11
PRINTED CIRCUIT BOARDS .....	15
EXPLODED VIEW OF CABINET .....	20
PARTS LIST .....	21
PACKING INSTRUCTIONS .....	24

**MITSUBISHI ELECTRIC SALES AMERICA, INC.**  
 3030 East Victoria Street Rancho Dominguez, California 90221

## SPECIFICATIONS

NOTE: All measurements are for 8 ohms output unless otherwise stated.

### AMPLIFIER SECTION

35 watts per channel, min. RMS, at 8 ohms from 20Hz to 20kHz with no more than 0.015% total harmonic distortion.

45 watts per channel, min. RMS, at 4 ohms from 20Hz to 20kHz with no more than 0.05% total harmonic distortion.

38 watts per channel, min. RMS, into 8 ohms at 1kHz with 0.015% total harmonic distortion.

50 watts per channel, min. RMS, into 4 ohms at 1kHz with 0.015% total harmonic distortion.

#### Input sensitivity/impedance

PHONO . . . . . 2.25mV/50k ohms, 100PF  
AUX, PLAY . . . . . 150mV/50k ohms

#### Maximum input level

PHONO . . . . . 140mV

#### Output level/impedance

REC OUT1, 2 . . . . . 150mV/220 ohms

#### Frequency response

PHONO . . . . .  $\pm 0.3$ dB, 20Hz – 20kHz,  
RIAA

AUX, PLAY . . . . .  $\pm 0.2$ dB, 20Hz – 20kHz

#### Total harmonic distortion (20Hz – 20kHz)

PHONO . . . . . 0.01%

AUX, PLAY . . . . . 0.01%

#### Signal to noise ratio

PHONO (10mV) . . . . . 94dB

PHONO (new IHF) . . . . . 78dB

AUX, PLAY (150mV) . . . . . 106dB

AUX, PLAY (new IHF) . . . . . 87dB

#### Residual noise

(IHF A-weighted) . . . . . 0.1mV

#### Tone control

BASS (boost/cut) . . . . .  $\pm 10$ dB at 100Hz

TREBLE (boost/cut) . . . . .  $\pm 10$ dB at 10kHz

#### Loudness control (Level-related equalization)

(attenuation) . . . . . –30dB

#### Filter characteristics

Low filter . . . . . 18Hz, 12dB/oct

### FM SECTION

Tuning range . . . . . 87.9 – 107.9MHz  
(200kHz step)

#### Usable sensitivity (IHF)

75 ohms . . . . . 0.9 $\mu$ V (10.8dBf)

300 ohms . . . . . 1.9 $\mu$ V (10.8dBf)

#### 50dB quieting sensitivity

MONO . . . . . 3.6 $\mu$ V (16.4dBf)

STEREO . . . . . 41 $\mu$ V (37.3dBf)

Image response ratio . . . . . 45dB

IF response ratio . . . . . 80dB

Spurious response ratio . . . . . 70dB

AM suppression ratio . . . . . 50dB

Capture ratio . . . . . 1.5dB

#### Alternate channel selectivity

(IHF  $\pm 400$ kHz) . . . . . 60dB

#### Signal to noise ratio (IHF)

MONO (65dBf) 82dB . . . . . (85dBf) 82 dB

STEREO (65dBf) 74dB . . . . . (85dBf) 76dB

#### Total harmonic distortion (75kHz deviation)

MONO . . . . . 0.2%

STEREO . . . . . 0.3%

#### Subcarrier product ratio

(IHF) . . . . . 35dB

#### Stereo separation

1kHz . . . . . 40dB

10kHz . . . . . 35dB

#### Frequency response

30Hz to 15kHz . . . . .  $\pm 1$ dB

### AM SECTION

Tuning range . . . . . 522 – 1611kHz

Usable sensitivity . . . . . 300 $\mu$ V/m

Selectivity . . . . . 35dB

Signal to noise ratio . . . . . 50dB

Image response ratio . . . . . 30dB

IF response ratio . . . . . 40dB

Total harmonic distortion . . . . . 0.8%

### GENERAL

Power consumption . . . . . 120W

Dimensions (W x H x D) . . . . . 470 x 135 x 436mm  
(18-1/2 x 5-3/8 x 17-1/5")

Weight . . . . . 9.5kg (21 lbs)

\* Design and specifications are subject to change without notice for improvement.

# FRONT PANEL TERMINOLOGY AND FUNCTIONS

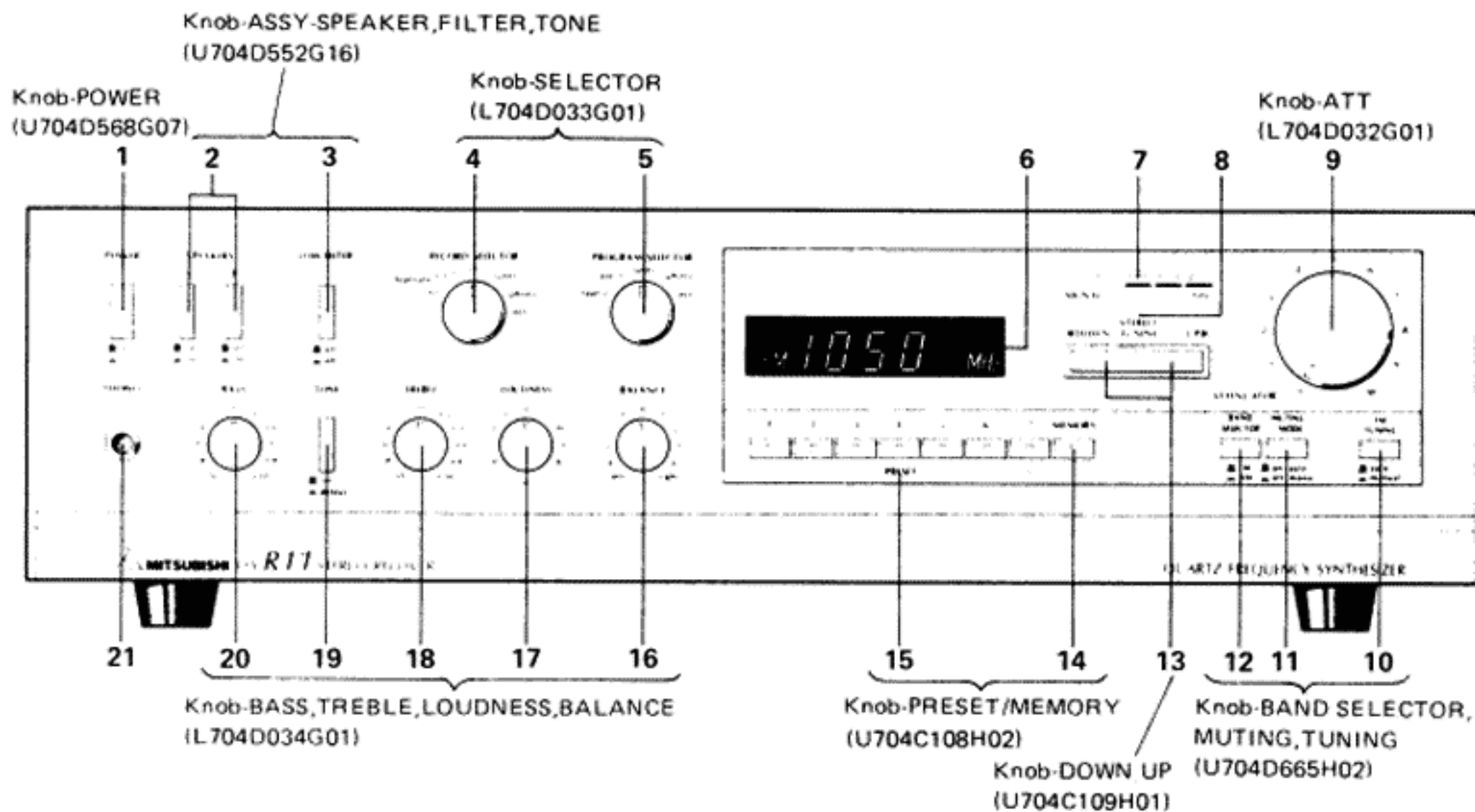

## 1. POWER (Power Switch)

This switch is for turning this unit on and off. When in the ON position, the digital frequency display is illuminated.

## 2. SPEAKERS (Speaker Selection Switches)

These switches control speaker selection.

- |   |   |   |
|---|---|---|
| A | B |   |
| ■ | ■ | For listening with headphones. The speakers are disconnected. |
| ■ | ■ | For listening to the speakers connected to terminals A.       |
| ■ | ■ | For listening to the speakers connected to terminals B.       |
| ■ | ■ | For listening to the speakers connected to terminals A and B. |

## 3. LOW FILTER (Low Frequency Filter Switch)

This filter attenuates the frequencies below 18Hz by 12dB/octave. It is normally used only when reproducing discs, where it eliminates unwanted low frequency noise and helps to prevent acoustic feedback.

## 4. RECORD SELECTOR (Selection Switch for Recording)

This switch selects which program can be recorded by the tape decks connected to the TAPE 1 and TAPE 2 terminals. It can also be used when duplicating is performed independently of the program selected for audition by the PROGRAM SELECTOR switch.

**DUPLICATE** This position is used to duplicate 1 → 2 from the tape deck connected to the PLAY 1 inputs to the tape deck connected to the REC 2 outputs.

**DUPLICATE** This position is used to duplicate 2 → 1 from the tape deck connected to the PLAY 2 inputs to the tape deck connected to the REC 1 outputs.

## 5. PROGRAM SELECTOR (Program Audition Selection Switch)

This switch selects the desired program source for audition. It operates independently of the source selected for recording, but can be used for monitoring.

- tape 2** This position is used to playback or monitor the recording of a tape deck connected to the PLAY 2 inputs.
- tape 1** This position is used to playback or monitor the recording of a tape deck connected to the PLAY 1 inputs.
- tuner** This position is for listening to programs on the AM/FM tuner section.
- phono** This position is for listening to a turntable unit connected to the PHONO inputs.
- aux** This position is for listening to a second tuner, a turntable with a high output ceramic cartridge, an 8-track tape cartridge player, television audio, or any suitable high output sources connected to the AUX inputs.

## 6. DIGITAL FREQUENCY DISPLAY

The digits displayed here show the frequency to which the unit is tuned. If you know the frequency of a station you want to hear, just press the tuning control until that frequency is displayed.

## 7. SIGNAL (Signal Strength Indicator)

This indicator shows the signal strength level of AM and FM broadcasts. For AM broadcasts, the best position for reception is obtained when the maximum number of indicator lamps are illuminated. For FM broadcasts, the best position for reception is obtained when the maximum number of indicator lamps are illuminated and the center indicator of the tuning indicator is illuminated.



## 8. STEREO (Stereo Indicator)

This indicator is illuminated when an FM stereo broadcast is being received in the stereo mode. If the MUTING/MODE switch is in the OFF/MONO position, this indicator will not light.

**NOTE:** The FM stereo program will not be heard in stereo unless the MODE switch is also in the ON/AUTO position.

## 9. ATTENUATOR (Volume Control)

This control adjusts the sound volume from the speakers and the headphones. The volume is increased by rotating clockwise, and decreased by rotating counterclockwise.

## 10. FM TUNING

**■ auto** For automatic tuning operations.

**— manual** For manual tuning operations.

## 11. MUTING/MODE (Muting Mode Selection Switch)

This switch is for selecting the mode of FM reception required.

**on/auto** For FM stereo broadcast reception. In this position both interstation noise and stations too weak for good stereo reception are muted while tuning.

**off/mono** For receiving FM broadcasts (including stereo broadcasts) monaurally. Muting is off, and both the interstation noise and the weaker stations will be heard.

## 12. BAND SELECTOR (Band Selection Switch)

This switch is for selecting FM or AM band reception.

**FM ■** For receiving FM broadcasts.

**AM —** For receiving AM broadcasts.

## 13. TUNING CONTROL

When the UP or DOWN button is pressed with the FM TUNING switch in the AUTO position (only FM), the reception frequency will change continuously until a broadcasting frequency is reached. If then pressed again, the reception frequency will continue to change until the next broadcasting frequency is reached. When the UP or DOWN button is pressed with the TUNING switch in the MANUAL position, however, the reception frequency will be increased or decreased by a 0.2MHz (FM) 10kHz (AM) step. Keeping the UP or DOWN button depressed, will cause the frequency to be changed continuously until the button is released.

## 14. MEMORY

When this button is pressed, the MEMORY indicator illuminates for about 5 seconds. To preset a particular broadcasting station in the memory, first tune to the desired frequency by operating the TUNING buttons, press this MEMORY button, and then while the MEMORY indicator remains on, press a suitable PRESET button. In order to remember the frequencies of preset stations even when the unit is switched off, this receiver has dry-cell batteries (provided in the accessories envelope) for back up memory. Please replace the same types of dry-cell batteries about every 3 years.

## 15. PRESET

When any of these buttons is pressed, the frequency already preset in memory will be tuned automatically. (The indicator in the button does not illuminate.)

## 16. BALANCE (Balance Control)

This control adjusts the balance between the two channels. There is a click-stop at the center position. Rotate clockwise to move the sound image to the right, and counterclockwise to move it to the left. Adjust the control to match any imbalance between the channels of the program sources, or to compensate for listening positions that are nearer one speaker than the other.

## 17. LOUDNESS (Loudness Compensation Control)

This control compensates for our ears reduced sensitivity to high and low frequencies at low listening volumes. First, rotate this control fully clockwise (to the zero position). Then turn up the volume to the highest level at which you will normally be listening, and adjust the bass and treble tone controls suitably. To listen at lower levels, use the LOUDNESS control, leaving the ATTENUATOR position unchanged. This will preserve the same tonal balance at all listening levels.

## 18. TREBLE (Treble Tone Control)

This control boosts or reduces the level of the response in the high frequency region. The zero position is off or flat: rotate it clockwise to increase the treble and counterclockwise to reduce the treble. The best setting will depend upon the characteristics of your speakers, your listening room, and your personal preferences.

## 19. TONE ON/DEFEAT (Tone Defeat Switch)

**on** In this position, both treble and bass tone controls are operative and may be adjusted.

**defeat** In this position the signal bypasses the treble and bass tone controls, and a completely flat frequency response is obtained.

## 20. BASS (Bass Tone Control)

This control boosts or reduces the level of the response in the low frequency region. The zero position is off or flat: rotate it clockwise to increase the bass and counterclockwise to reduce it. The best setting will depend upon the characteristics of your speakers, your listening room and your personal preferences.

## 21. PHONES (Headphone Output)

For stereo listening with headphones, plug the headphones into this output socket. Listening with headphones is possible at all positions of the SPEAKERS switches.

## DISASSEMBLY INSTRUCTIONS

### 1. Removal of Case (Top)

Remove four screws from both sides of the case.

### 2. Removal of Base (Bottom)

Remove screws as shown in Figure 1.

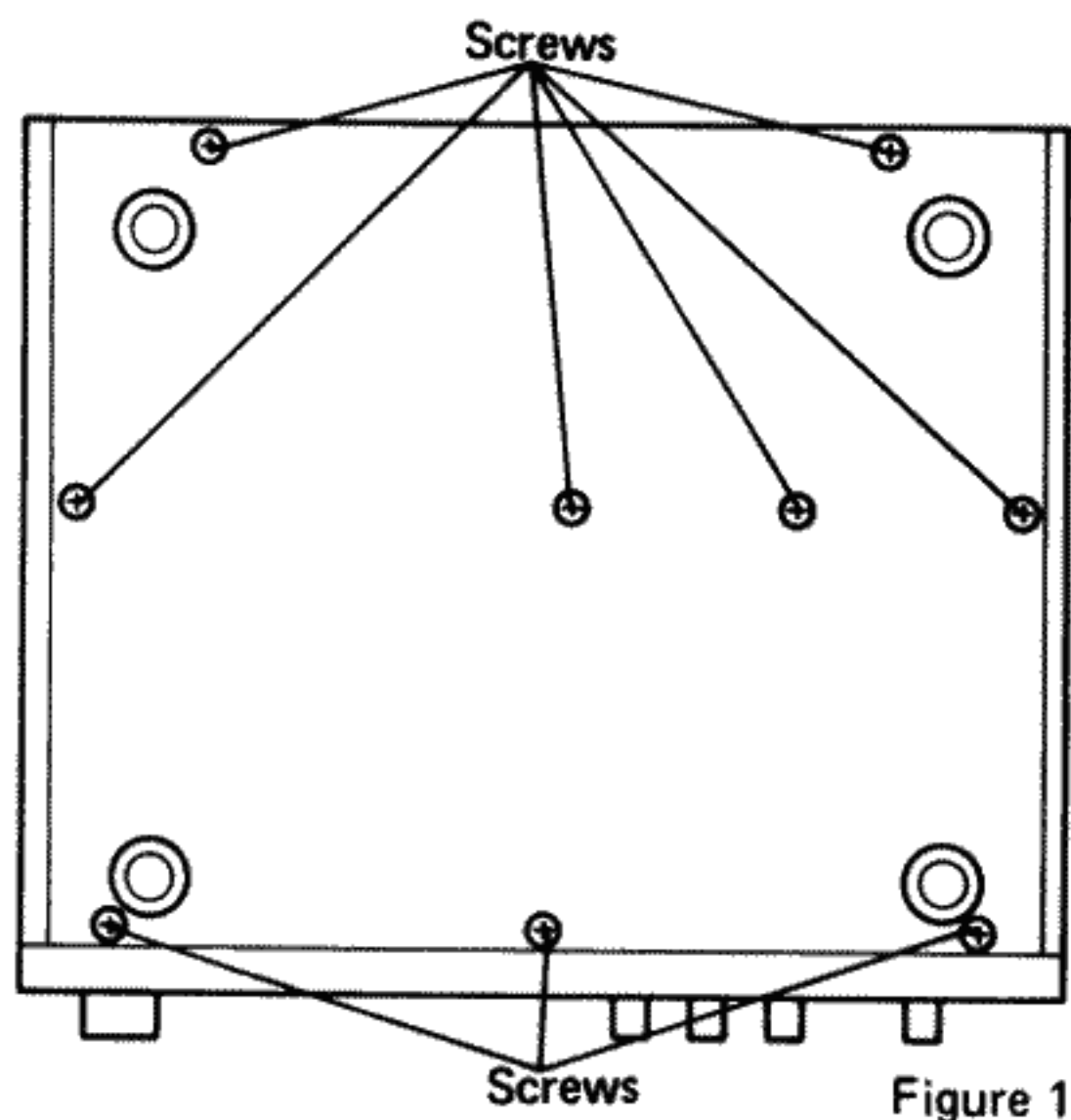

### 3. Removal of Panel Assembly

Remove two screws from top face of the panel.

### 4. Removal of Front P.C. Board

1) Remove a knob and two screws as shown in Figure 2.

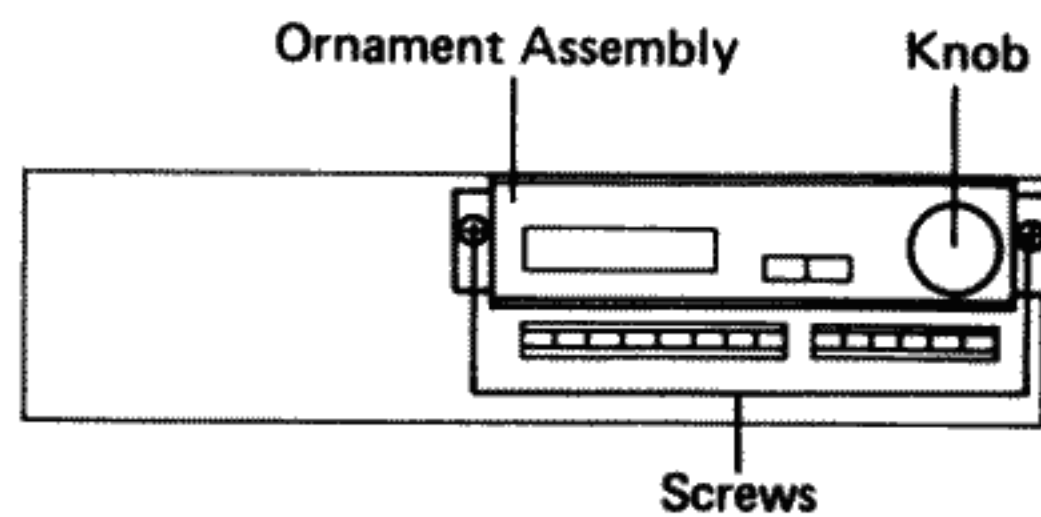

2) Remove knobs and screws as shown in Figure 3.

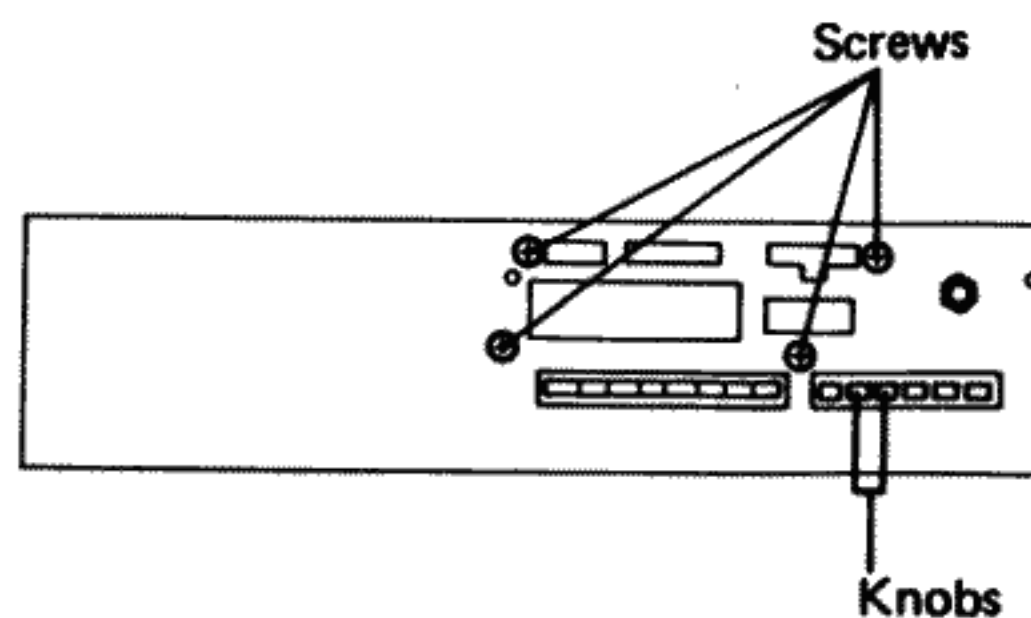

### 5. Removal of Connecting Parts of Switch

To remove part C, insert a driver in slot A and push part B out with the tip of the driver as shown in Figure 4.

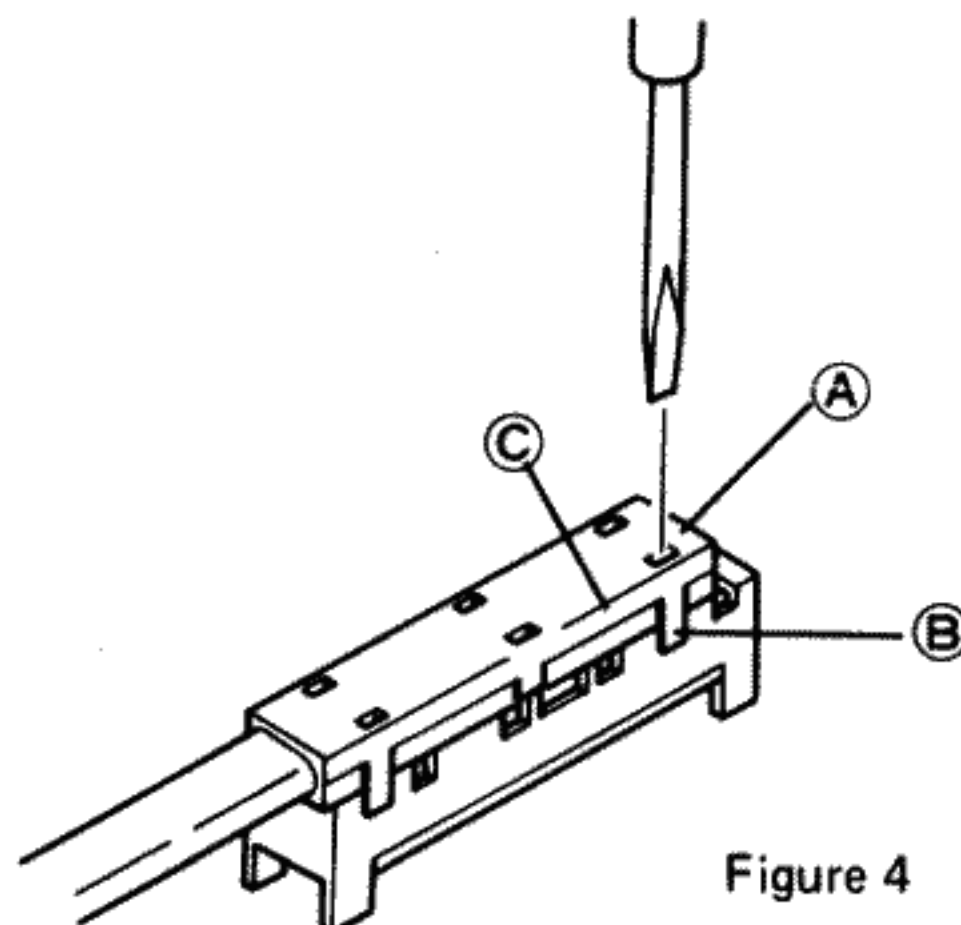

## FM ADJUSTMENT

### 1. Adjustment of FM Front End

- 1) Set trimmers TC101 – TC103 to center, as shown below.

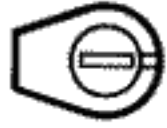

- 2) Set the frequency indicator to 87.9MHz. Measure a voltage on both ends of C812 and adjust it to  $8V \pm 1.0V$  by turning L103.
- 3) Set the frequency indicator to 107.9MHz. Measure the voltage on both ends of C812 and adjust it to  $22V \pm 1.0V$  by turning TC103.
- 4) Repeat steps 2) and 3) until the specified voltage is obtained for each frequency.
- 5) Adjust L101, L102 and T101, so that the U-curve of Q105 collector becomes maximum at a frequency in the above 2). (Refer to Fig. 5)
- 6) Adjust TC101 and TC102, so that the U-curve of Q105 collector becomes maximum at a frequency in the above 3). (Refer to Fig. 5)
- 7) Repeat steps 5) and 6). Note that the adjustment of T101 needs be made only once.

### 2. Adjustment of FM-IF

- 1) Allow the tuner to receive a 65dBf signal, with 100% modulation, at 98.1MHz and 1kHz, and measure a voltage on both ends of R125. Adjust primary core (on the side of IC101) of T102 to adjust the voltage to  $0V \pm 50mV$ .
- 2) Allow the tuner to receive a signal of 87.9MHz and adjust secondary core of T102 for minimum distortion factor.  
For the substandard distortion, adjust T101 within a range of  $\pm 90^\circ$ .

- 3) When a voltage obtained in step 1) exceeds the specified voltage, repeat Step 1).

### 3. Adjustment of FM-MPX

- 1) Allow the tuner to receive a 65dBf signal, without modulation, at 98.1MHz. Turn VR101 till the frequency at TP1 becomes  $19kHz \pm 0.05kHz$ .

NOTE: SSG frequency accuracy of FM is  $\pm 5kHz$ .

## AM ADJUSTMENT

- 1) Set TC201 and TC202 to center, as in the case of 1 – 1) of the FM Adjustment.
- 2) Set the frequency indicator to 530kHz, measure a voltage on both ends of C812, and adjust T201 for the voltage within  $1V \pm 0.1V$ .
- 3) Set the frequency indicator to 1620kHz, measure the voltage on both ends of C812, and adjust TC201 for the voltage within  $21V \pm 0.1V$ .
- 4) Repeat Steps 2) and 3).
- 5) Allow the tuner to receive a 600kHz signal, and adjust T202 for maximum output.
- 6) Allow the tuner to receive a 1400kHz signal, and adjust TC202 for maximum output.
- 7) Repeat Steps 5) and 6).
- 8) Allow the tuner to receive the signal as in step 5), and adjust T203 for maximum output.

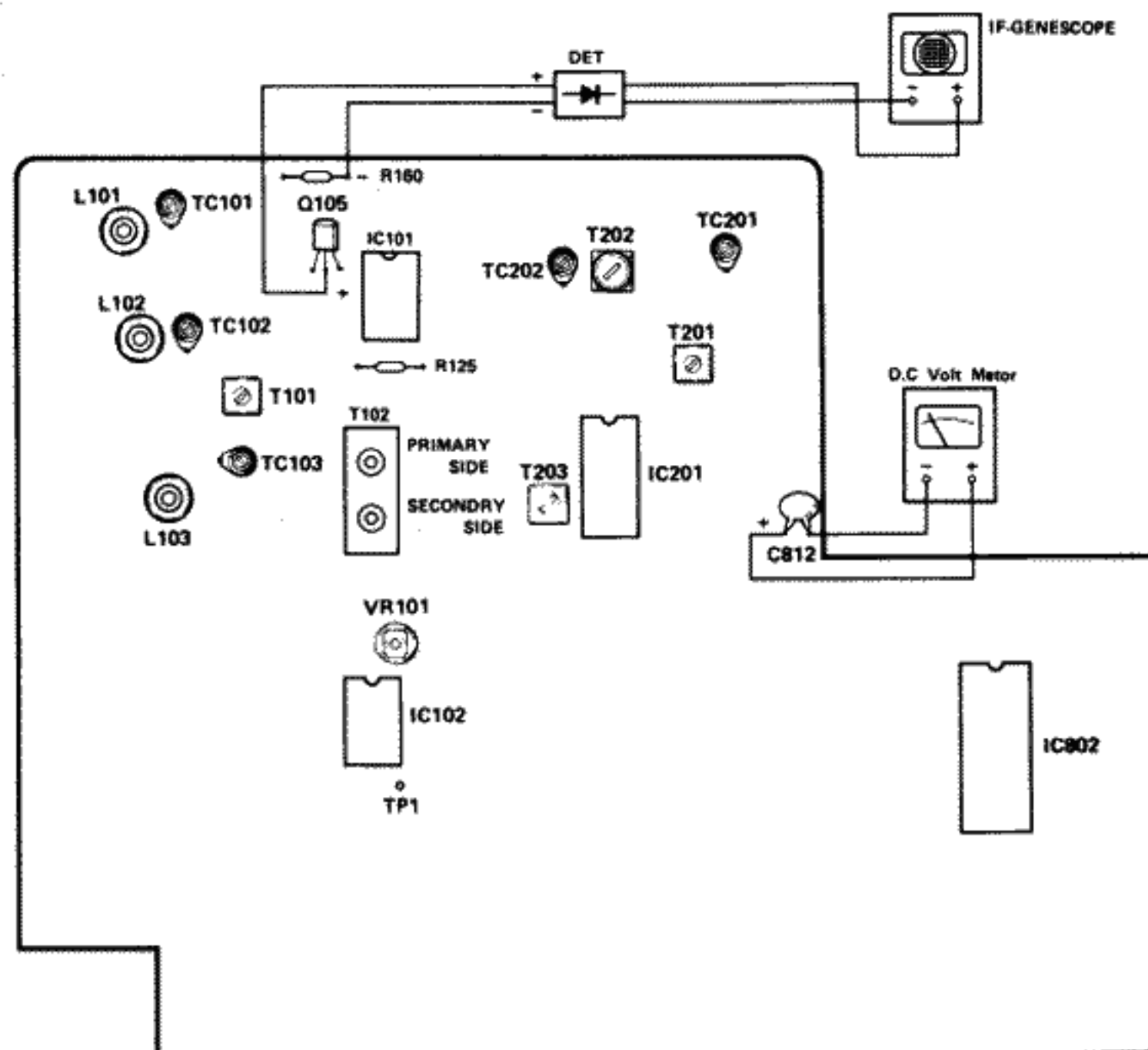
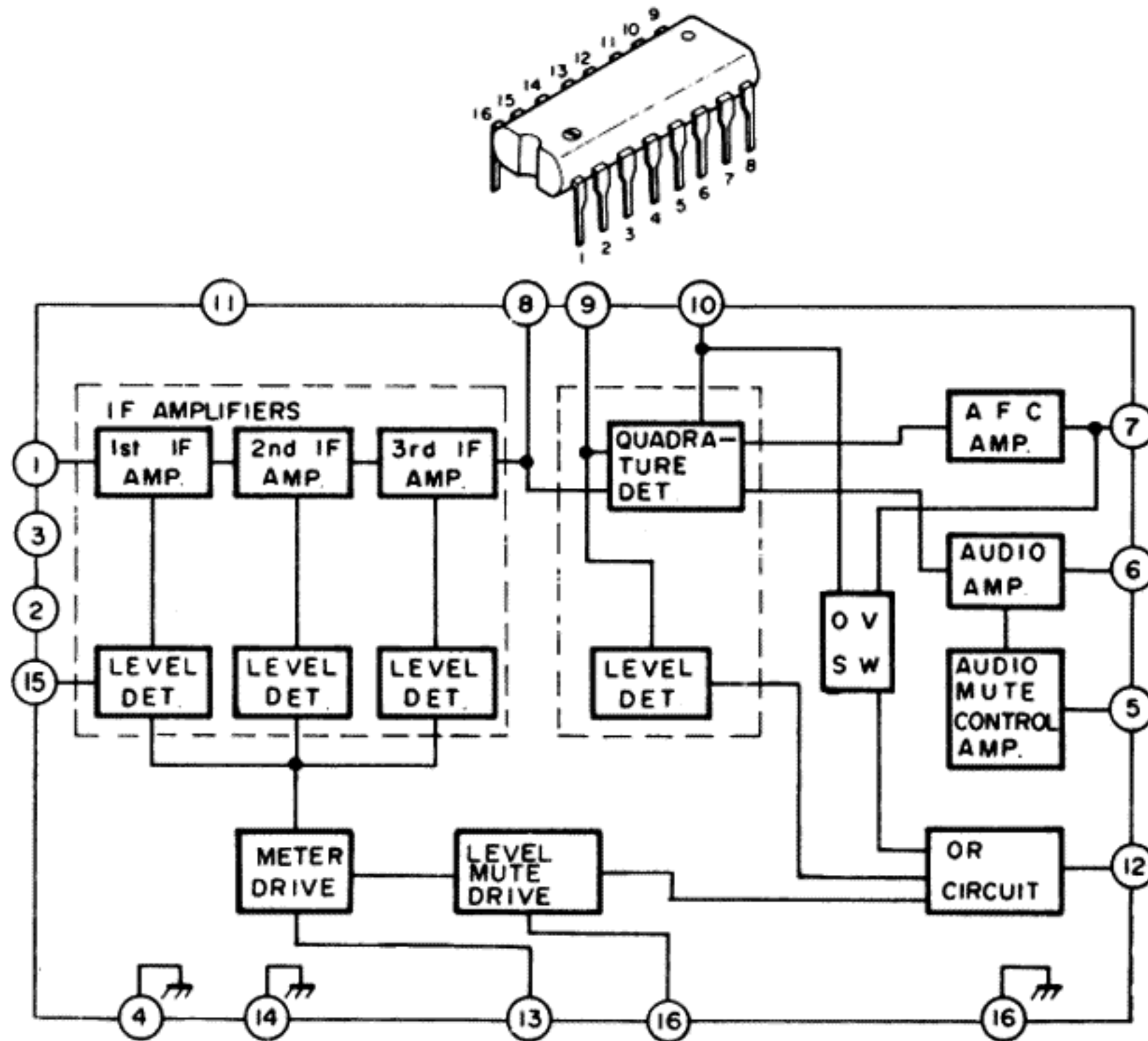

Figure 5



# INTERNAL DIAGRAMS AND PINOUT OF INTEGRATED CIRCUIT

**IC 101 ( FM-IF AMP )**  
**HA11225**



**IC 102 ( FM-MPX )**  
**μPC587C2**

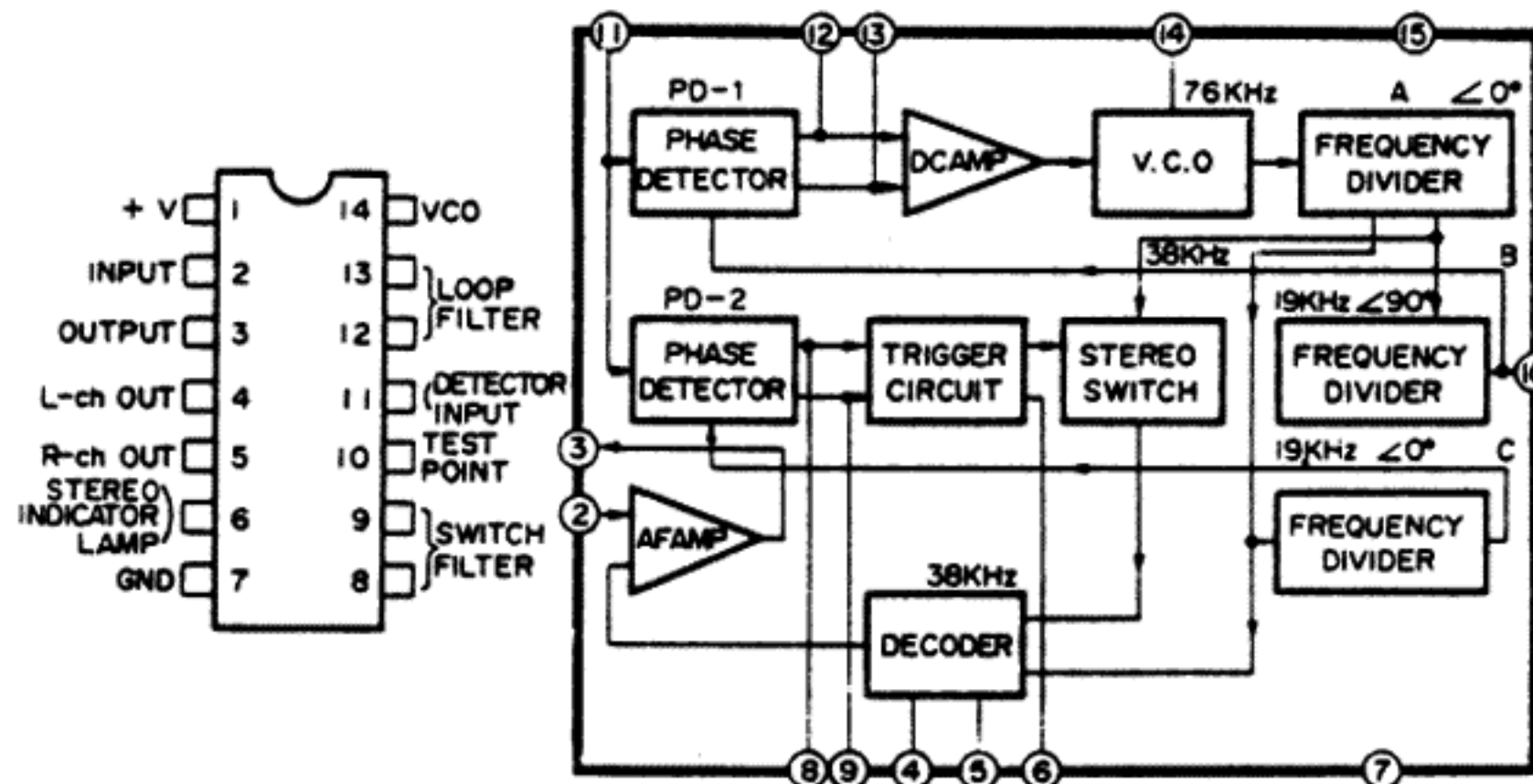

**IC 201 ( AM RF/OSC/MIX/IF/DET )**  
**LA1245**

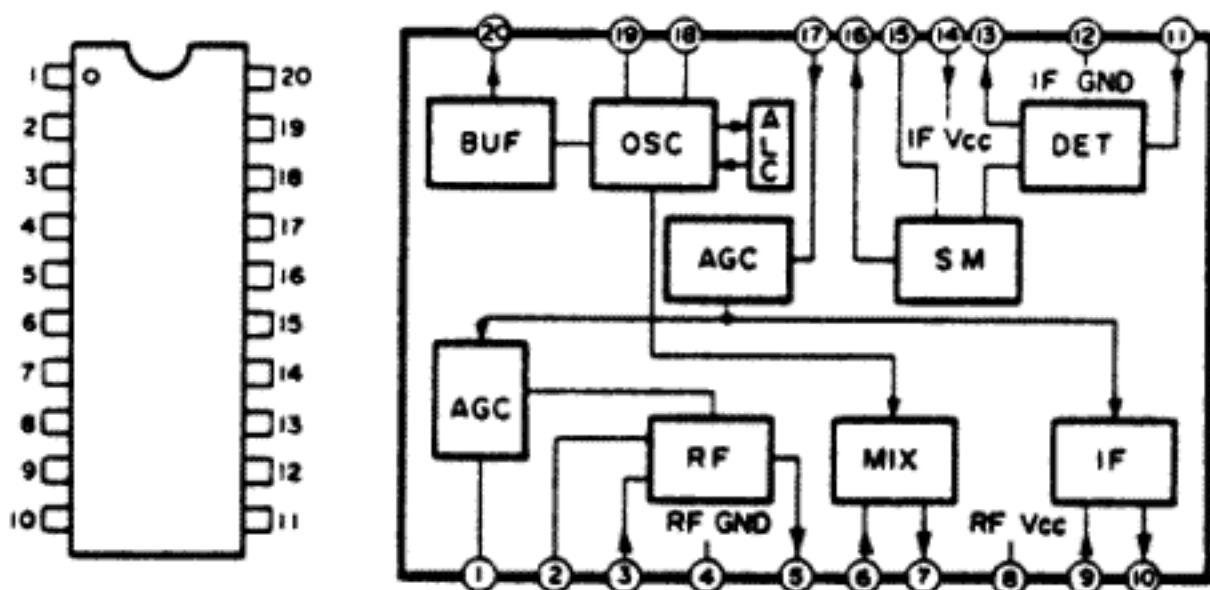

**IC 501 ( VOLTAGE AMP )**  
**STK-3042 (Mk2)**

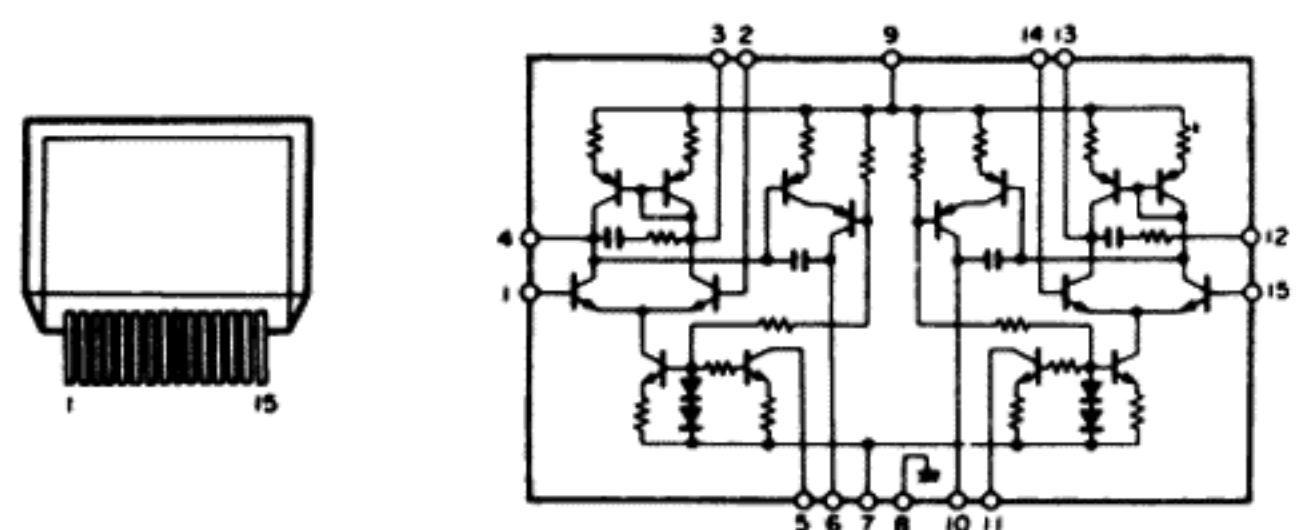

**IC 502, IC 602 ( POWER AMP )**  
STK-1039

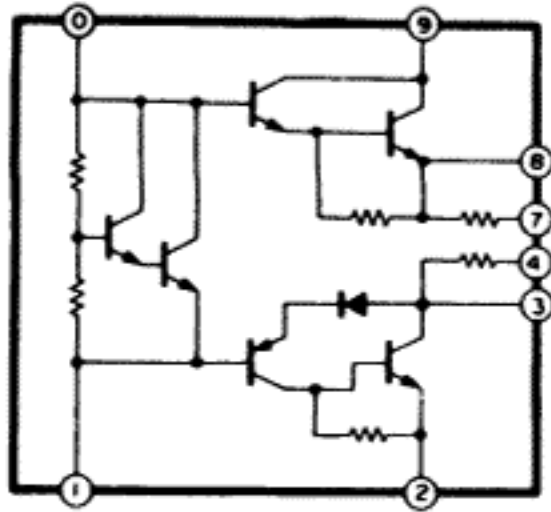
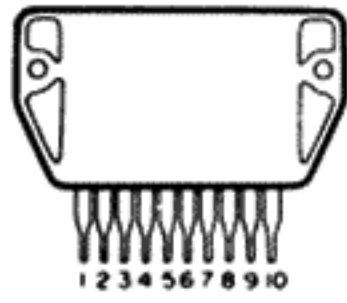

**IC 701 ( PROTECTOR )**  
HA12002

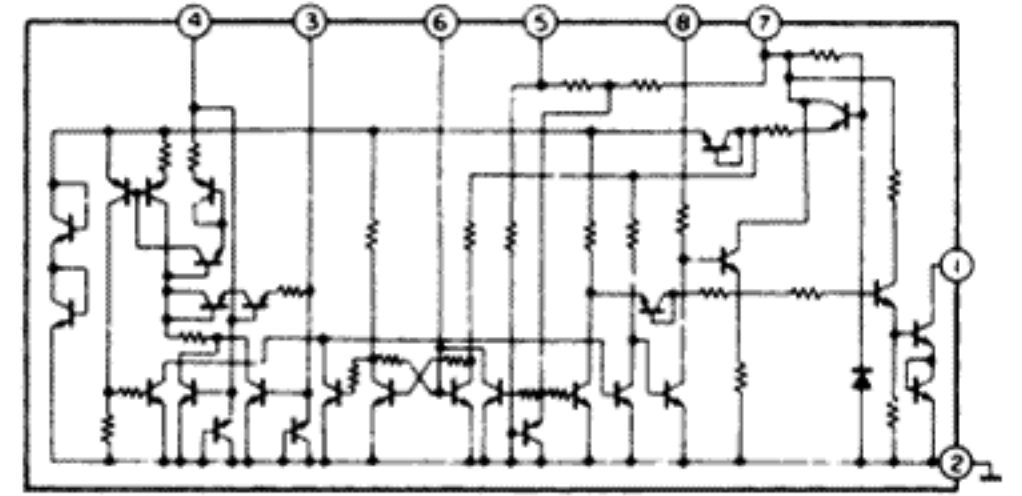
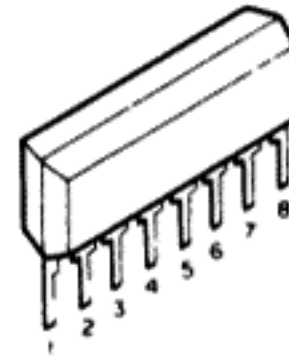

**IC 802 ( PLL-SYNTHESIZER CONTROL )**  
 $\mu$ PD1073

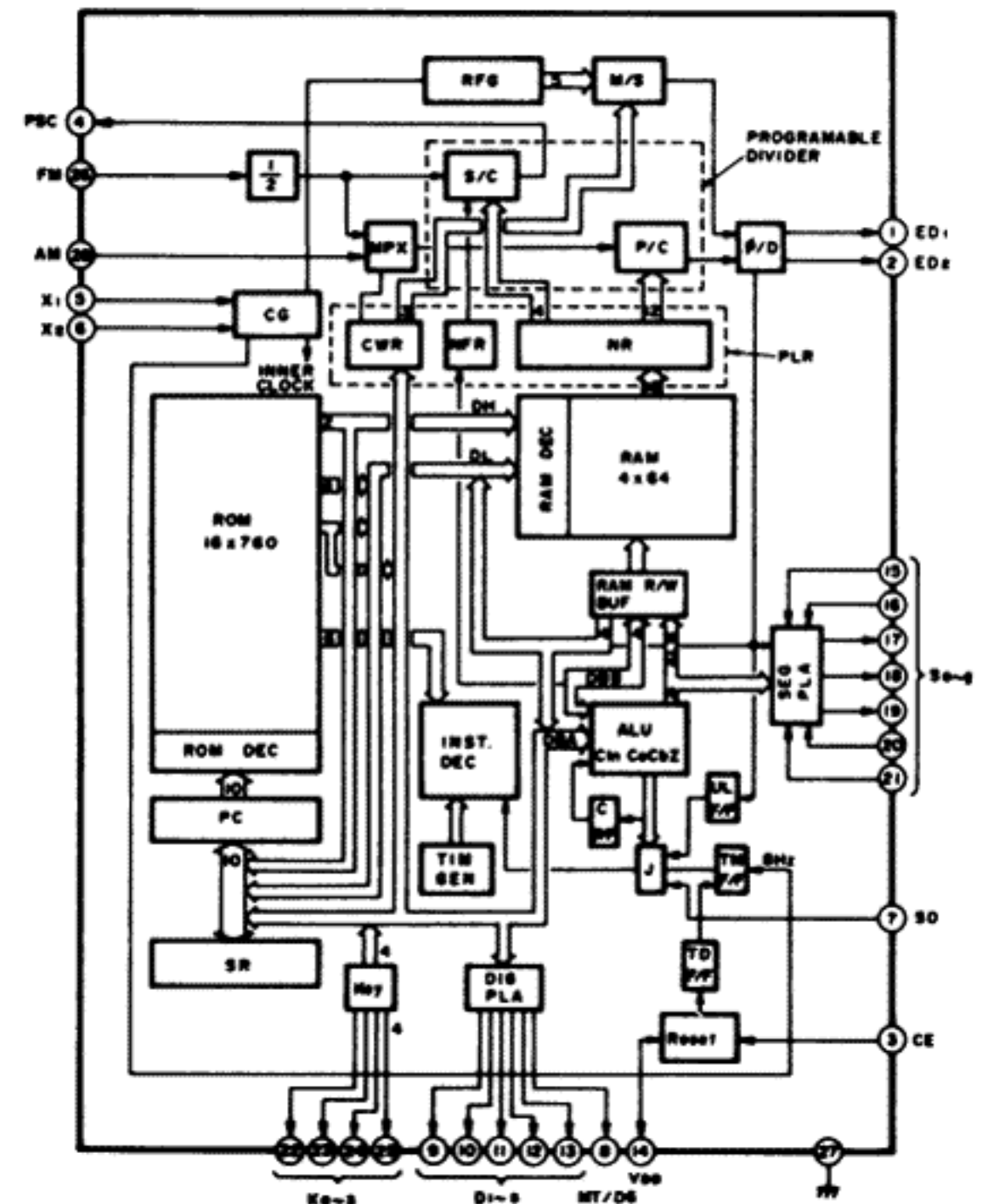
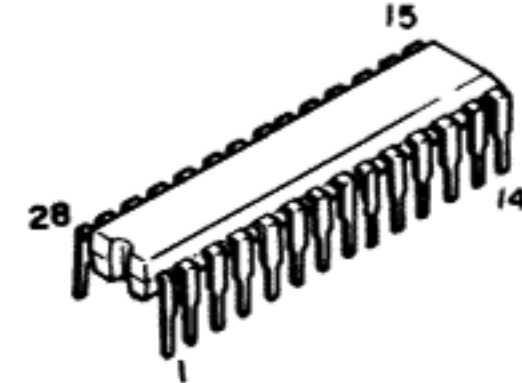

**IC 801 ( PRESCALER )**  
 $\mu$ PB553

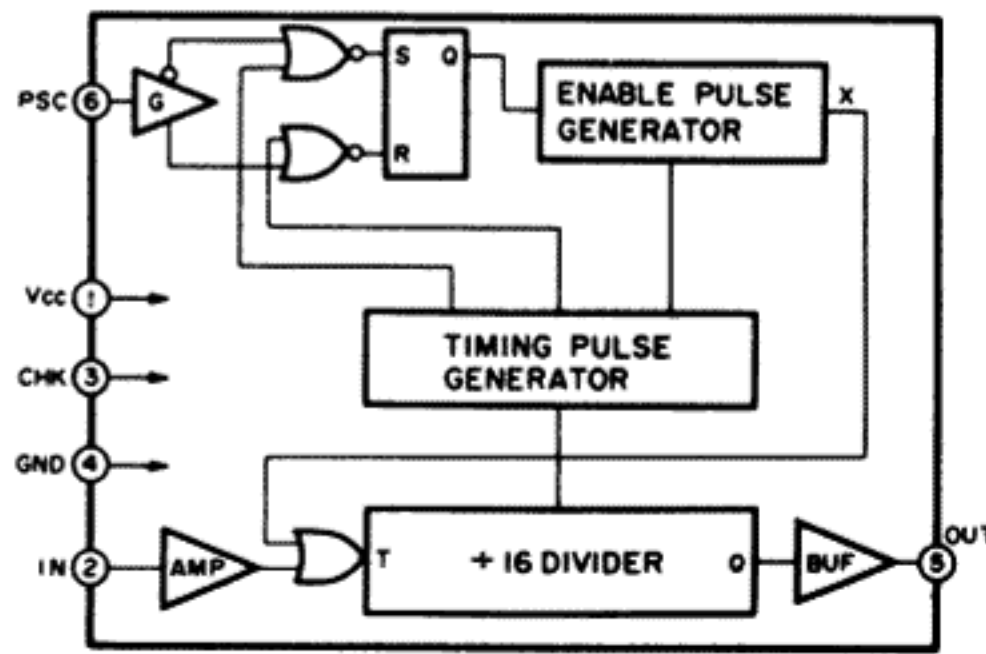
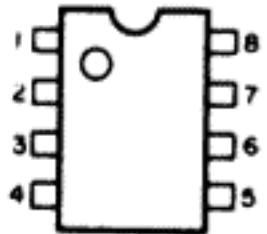

**IC 881 (+12v. REGULATOR )**  
 $\mu$ PC78M12H

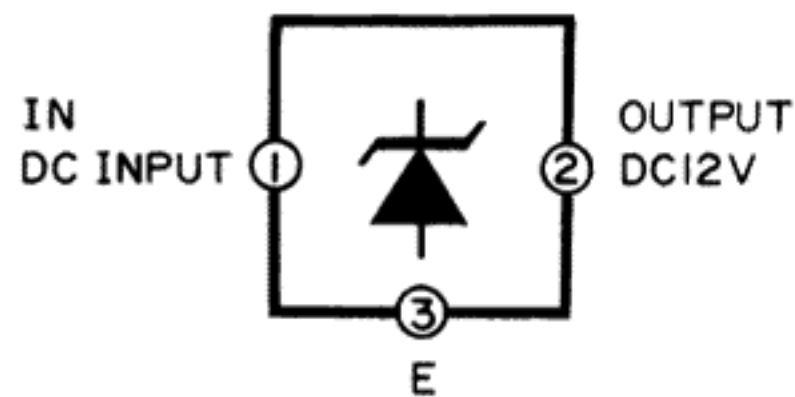
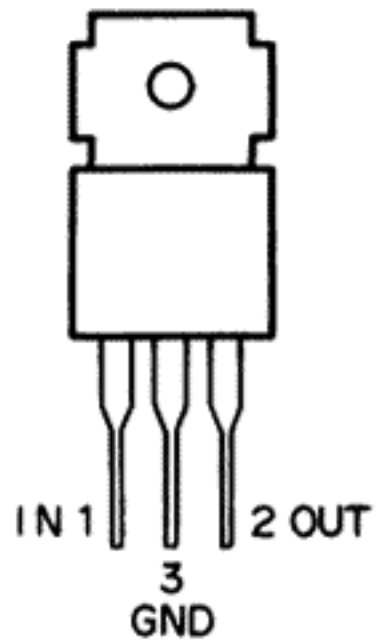

**IC 903 ( LED DRIVE )**  
SN16889P

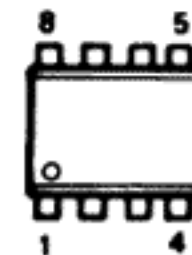

INPUT	OUTPUT				
A	O1	O2	O3	O4	O5
< 200mV	H	H	H	H	H
≥ 200mV	L	H	H	H	H
≥ 400mV	L	L	H	H	H
≥ 600mV	L	L	L	H	H
≥ 800mV	L	L	L	L	H
≥ 1000mV	L	L	L	L	L

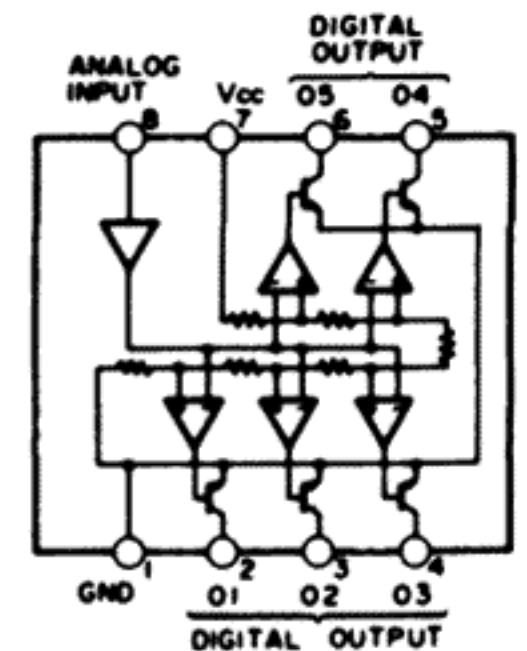



# WIRING DIAGRAM

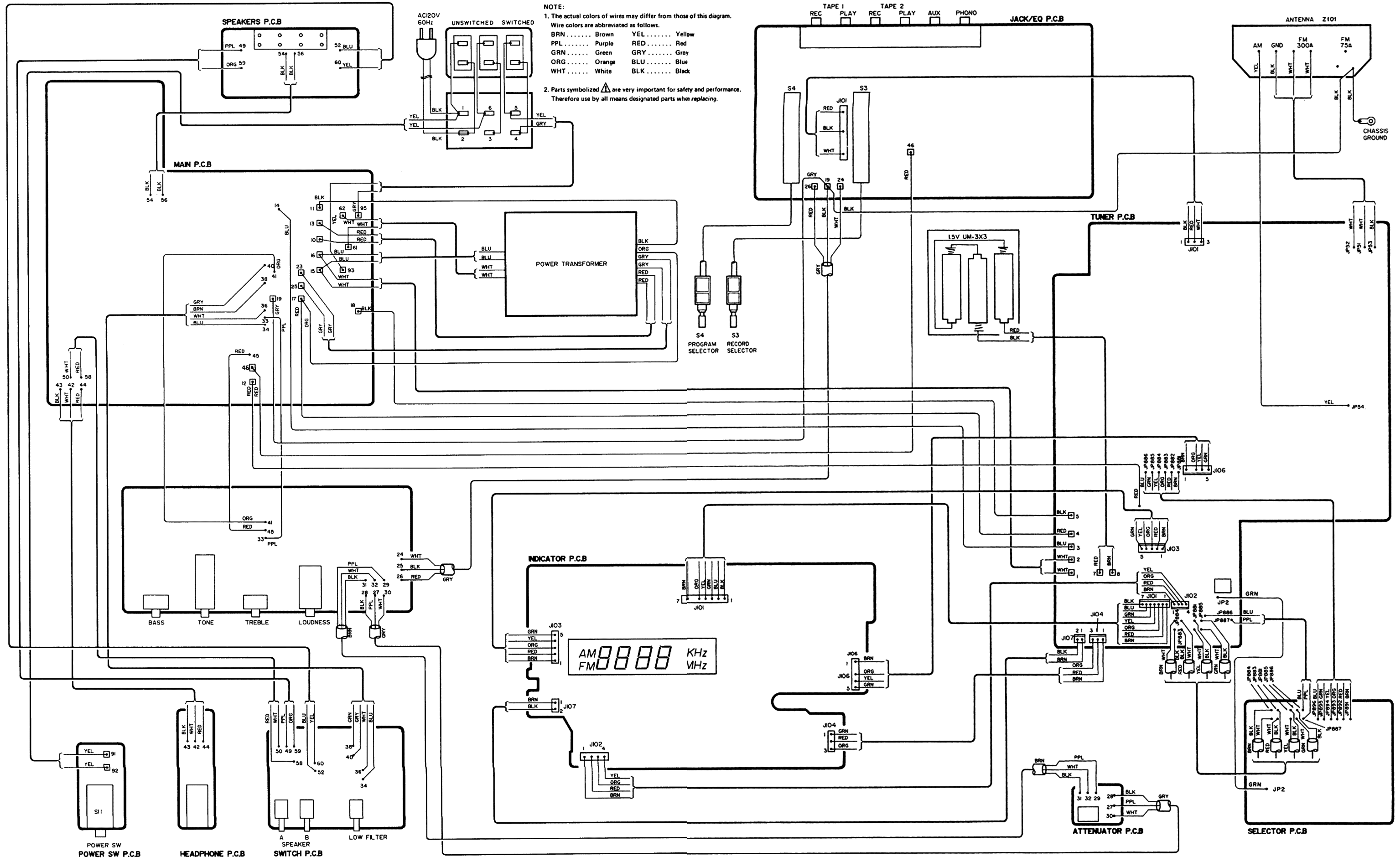



**SCHEMATIC DIAGRAM**



**NOTES:**  
 1. C and R unit  
 C ..... No symbol :  $\mu$ F  
 P ..... No symbol : pF  
 Capacitor without voltage display has pressure resistance of 50V.  
 The NP is Nonpolar Capacitors.  
 R ..... No symbol :  $\Omega$   
 K ..... No symbol : k $\Omega$   
 M ..... No symbol : M $\Omega$   
 Resistance not designated is 1/4, J(5%).  
 2. Voltage for all parts are measured in terms of DC 1M $\Omega$  digital voltmeter.  
 3. Parts marked with  $\Delta$  or  $\square$  are vital for maintenance of safety and performance. Be sure only designated parts are used for replacement.  
 4. The circuit figure shown here is the basic circuit diagram. Please note that changes in dimensions may occur as a result of improvements, etc.







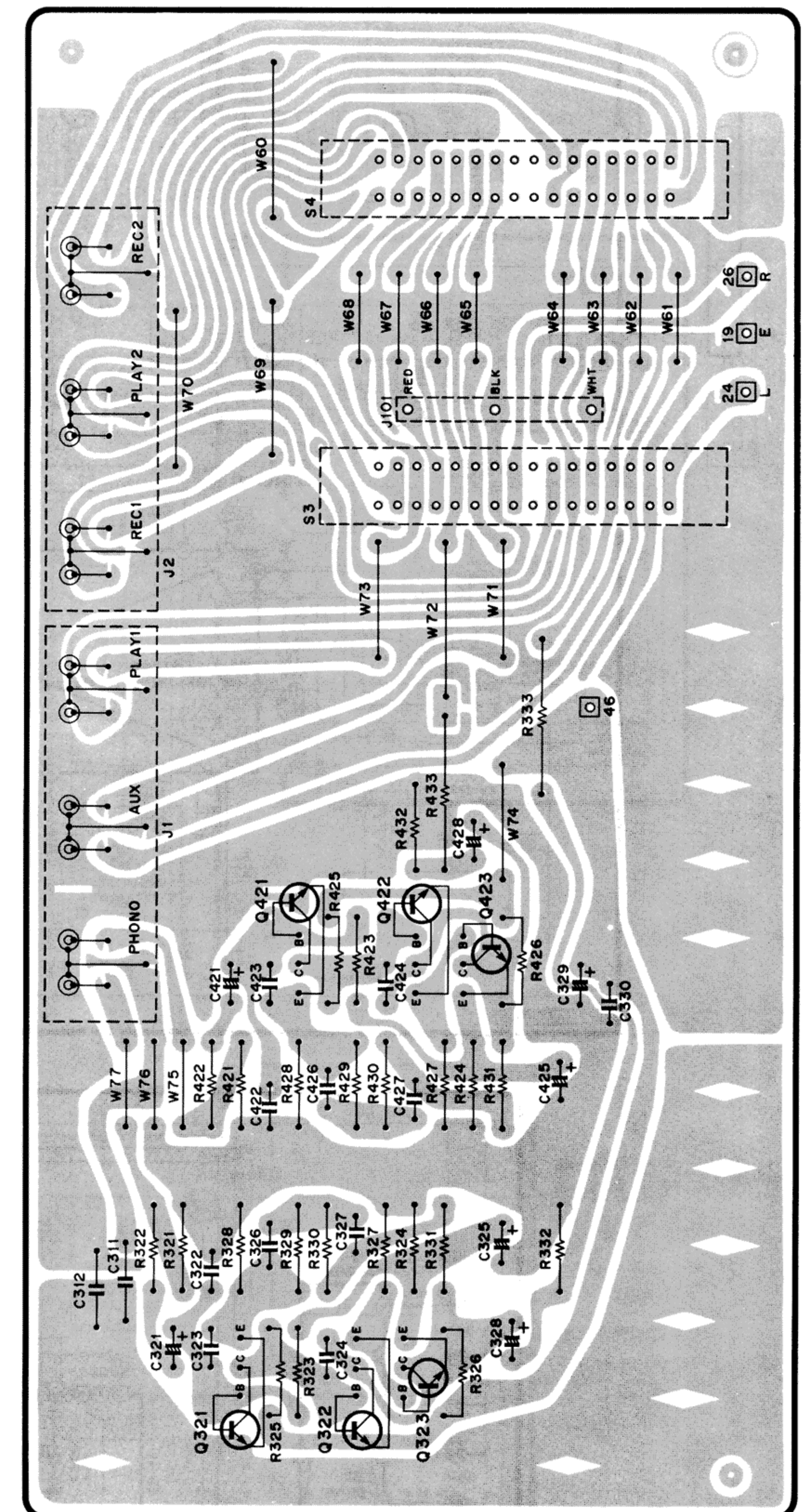
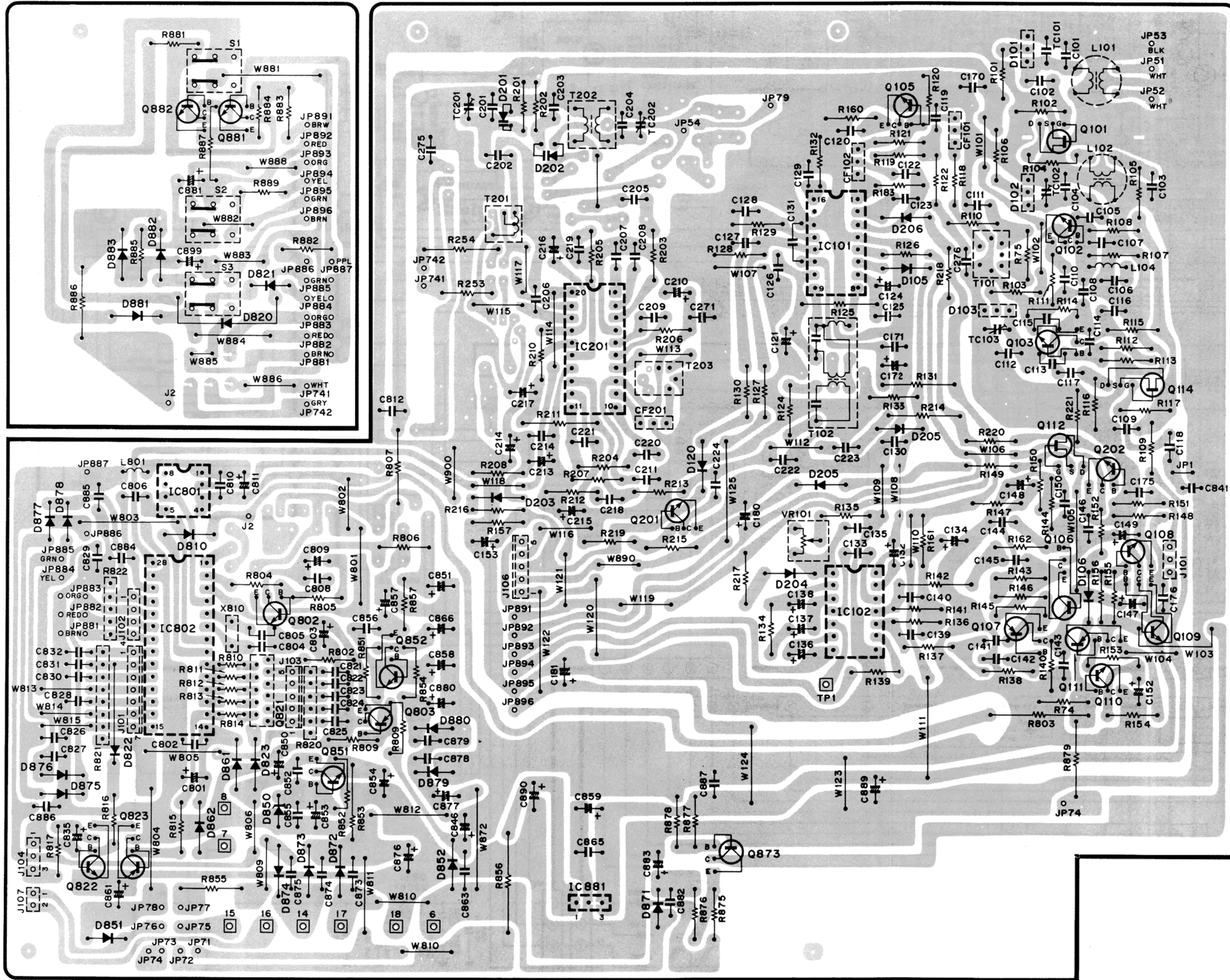



POWER

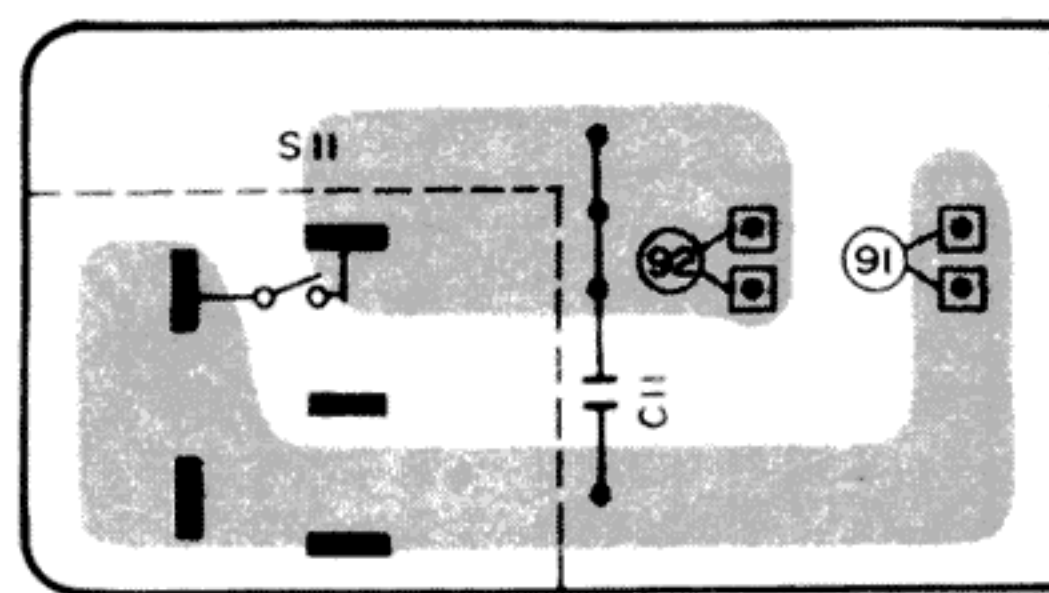

ATTENUATOR

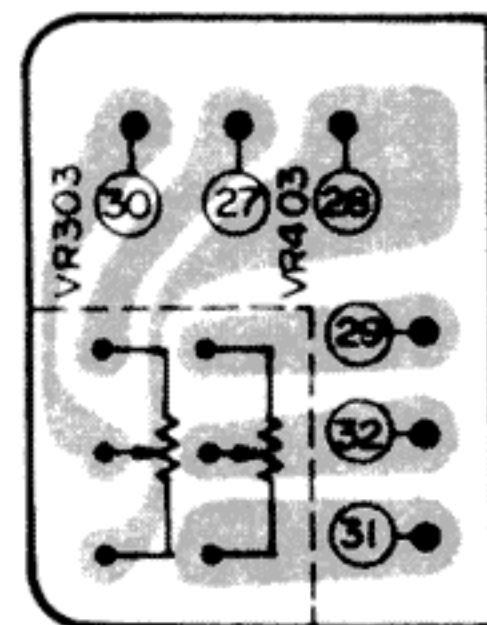

SPEAKER TERMINAL

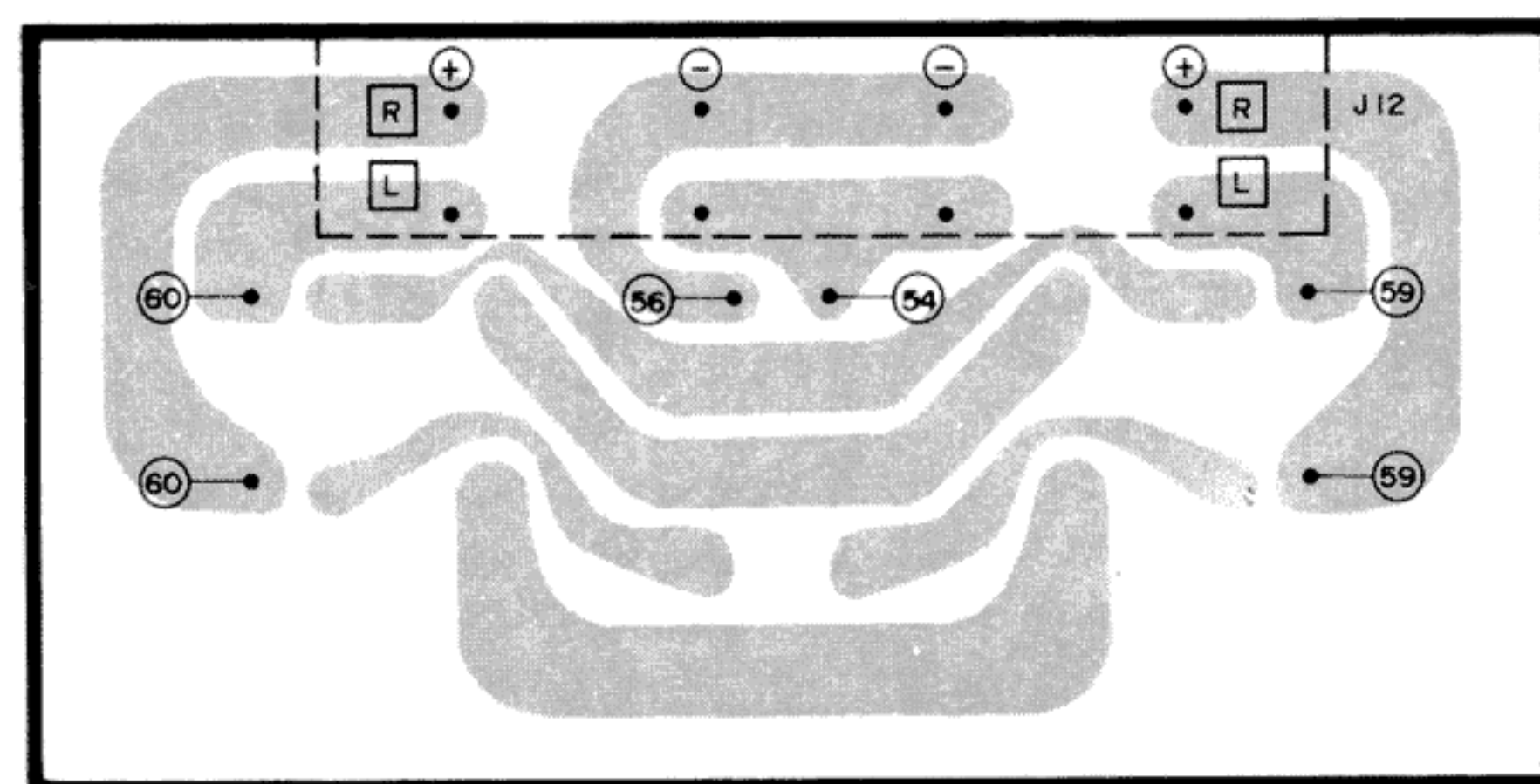

SPEAKERS

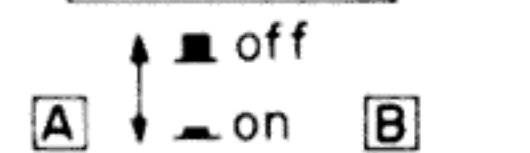

LOW FILTER

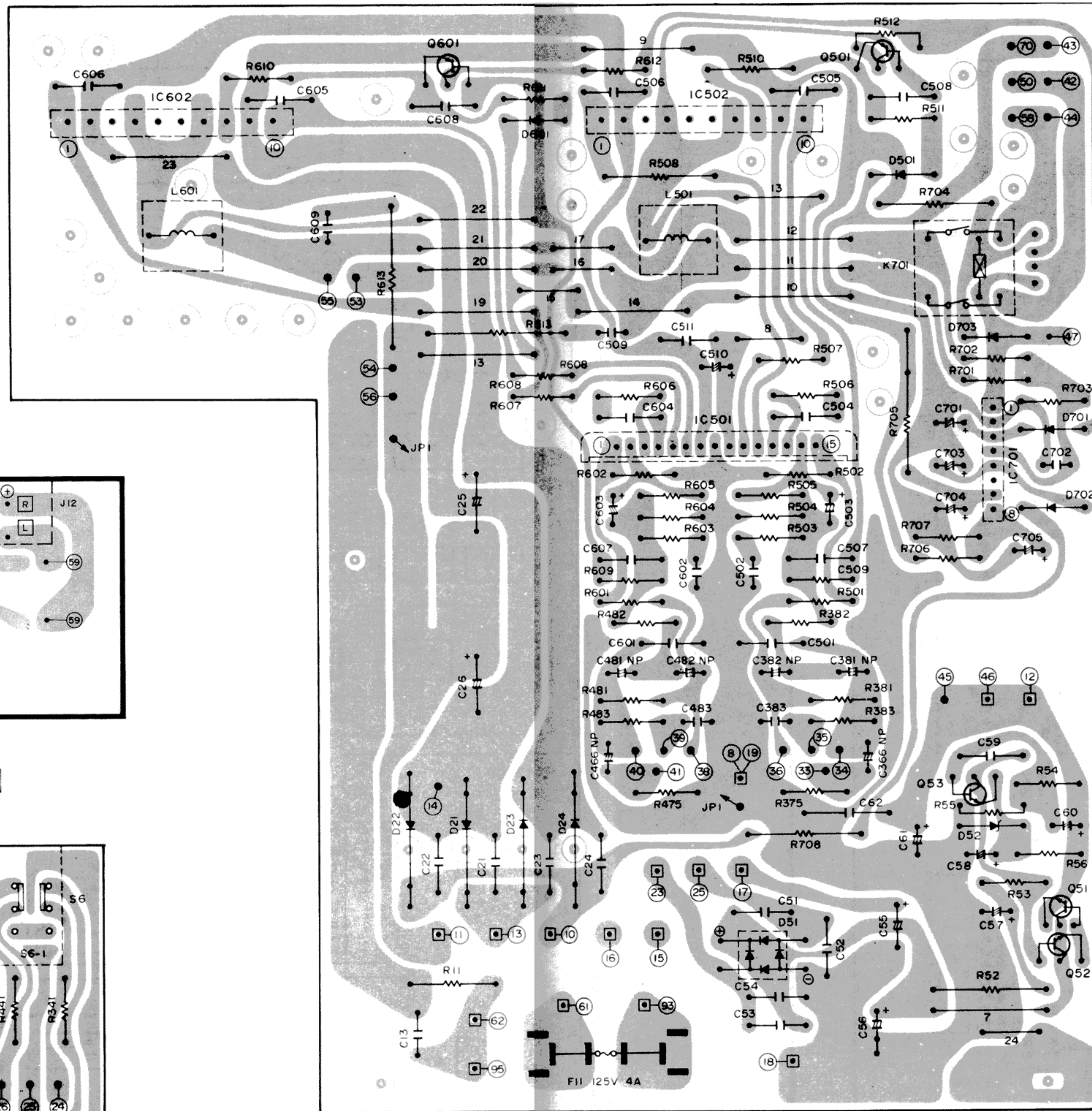
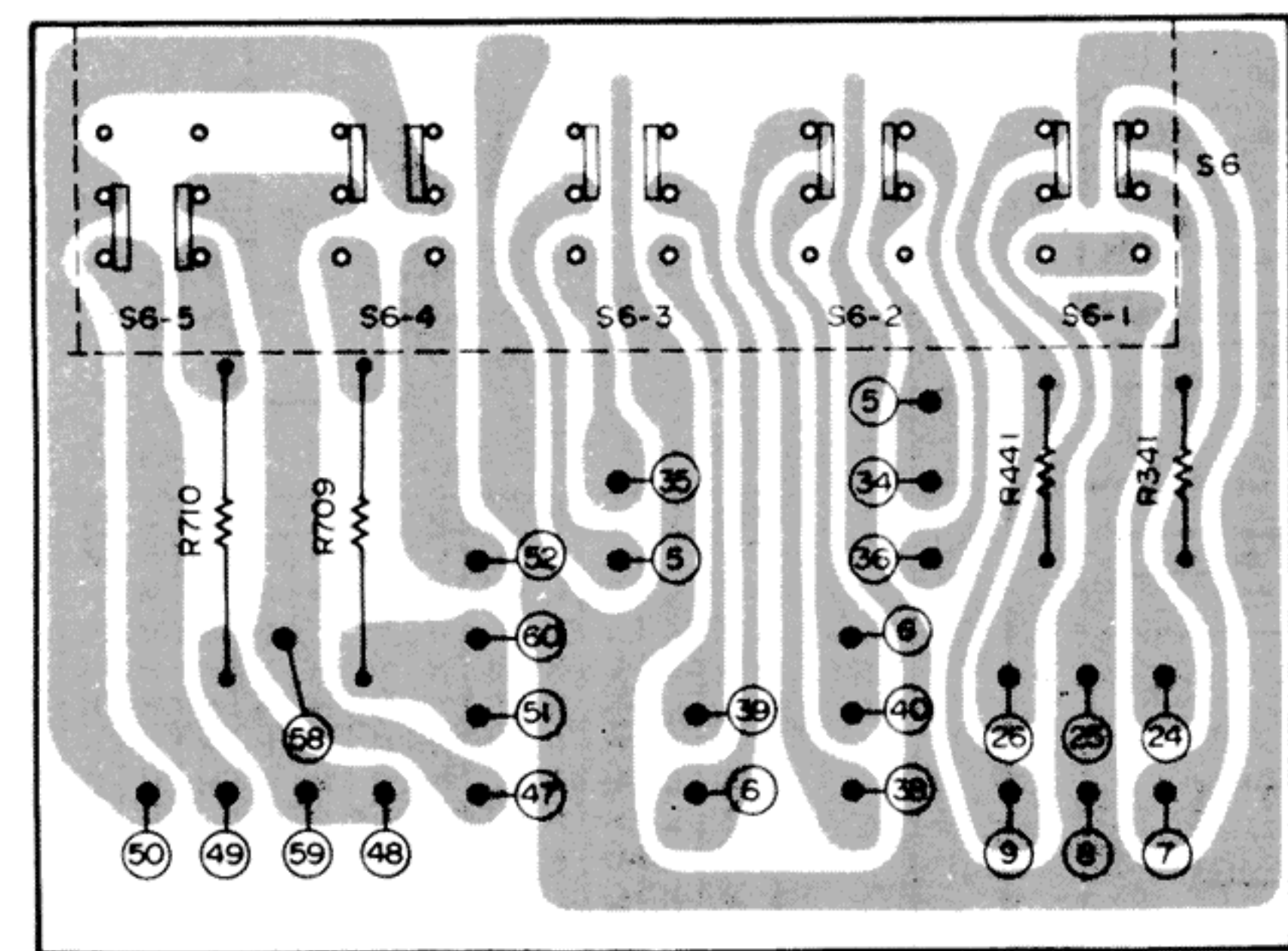
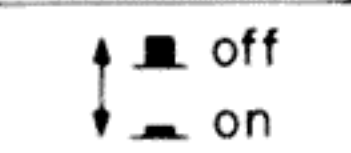

HEADPHONE JACK

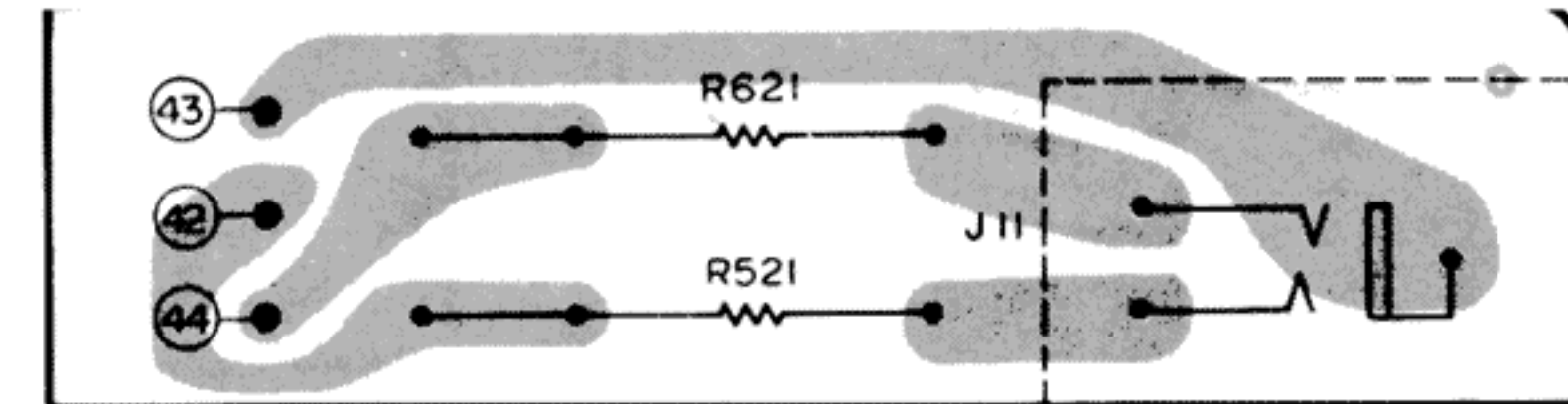

BASS

TONE

TREBLE

LOUDNESS

BALANCE

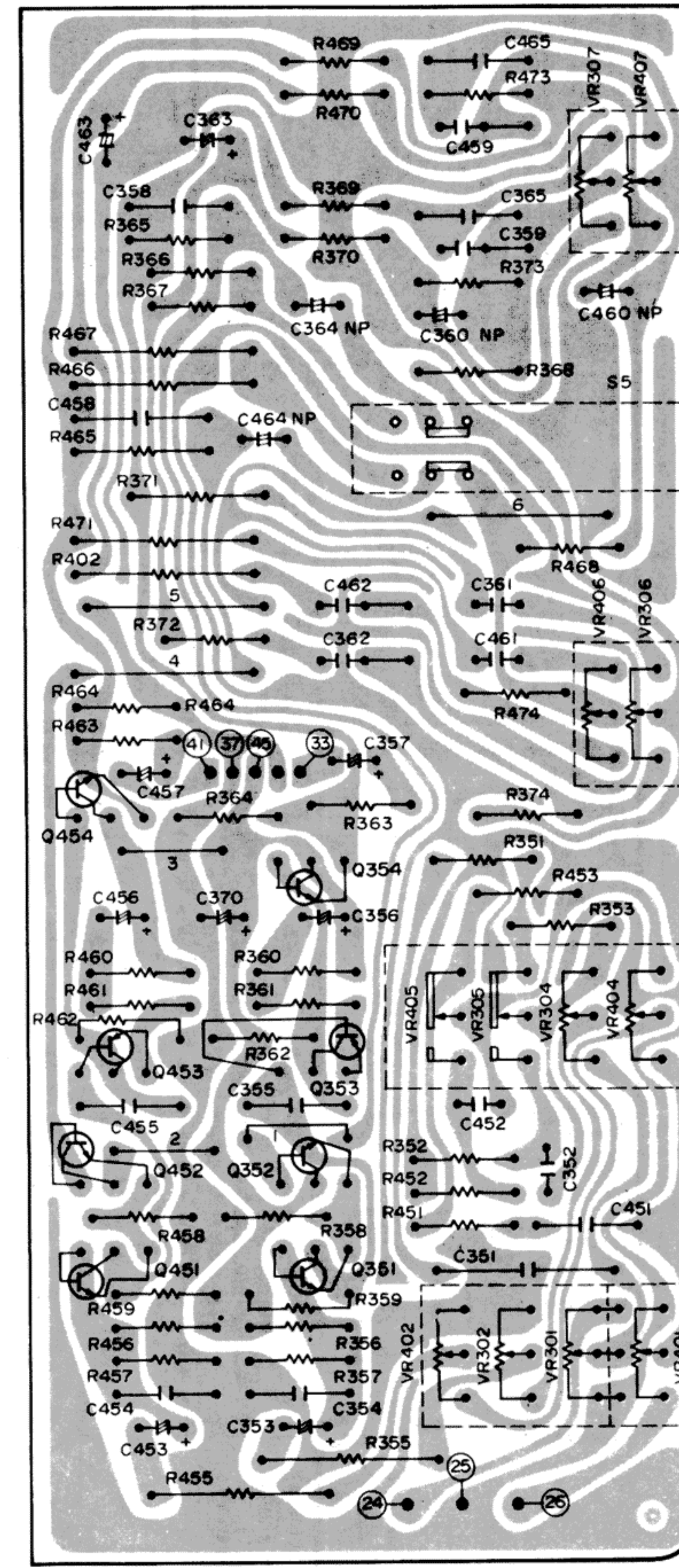



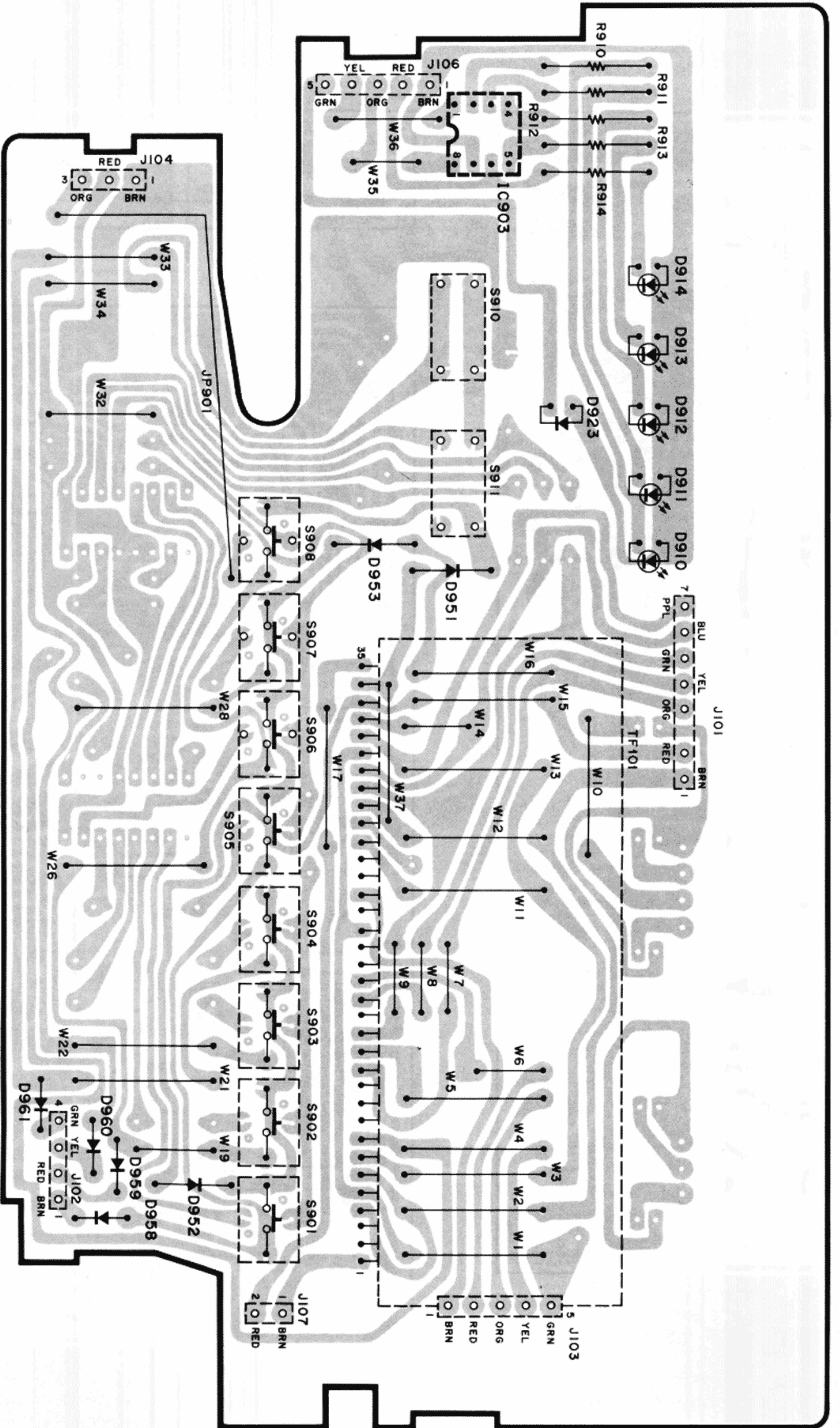



# EXPLODED VIEW OF CABINET

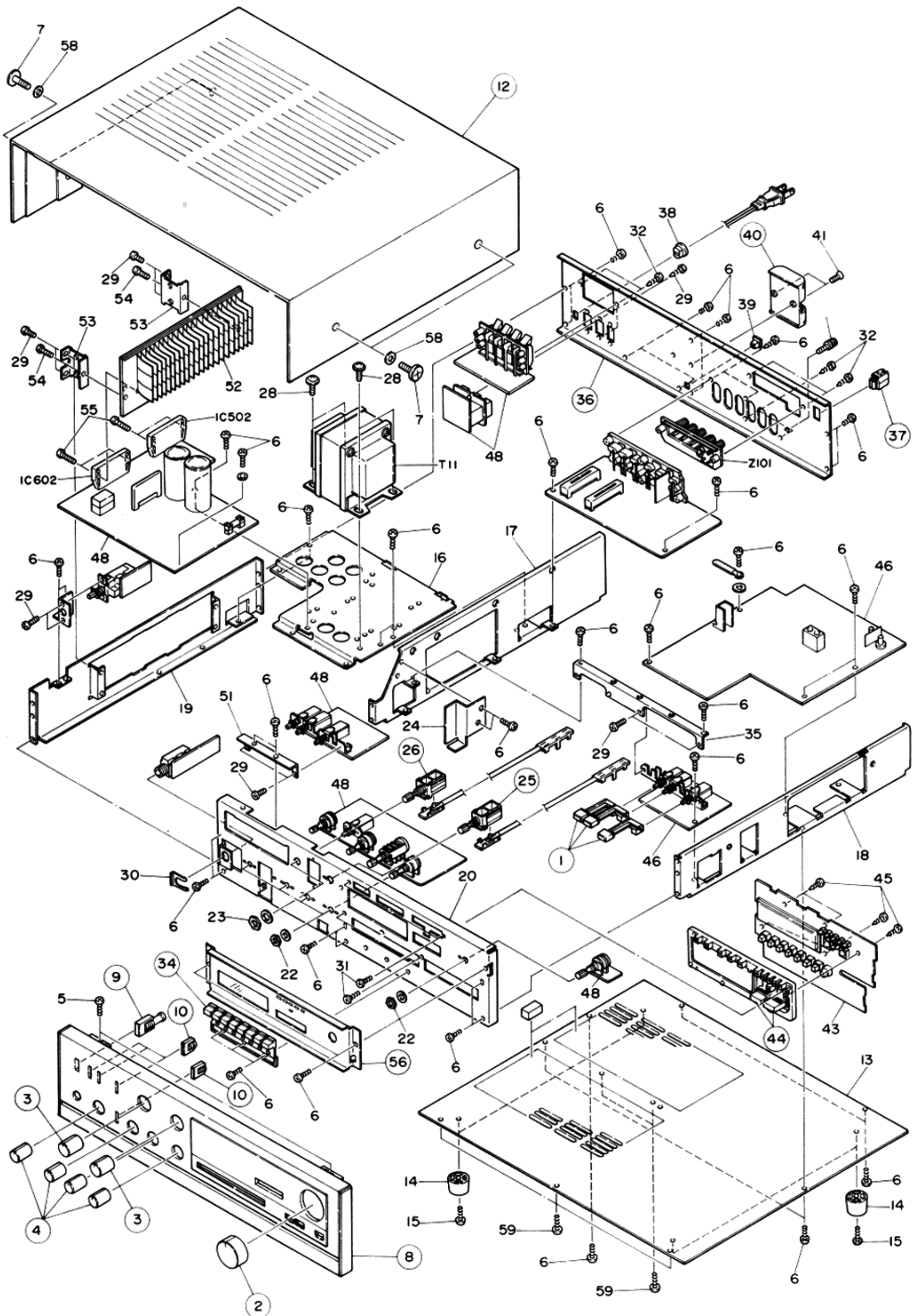

# PARTS LIST

**NOTE:**  $\Delta$  and  $\text{XXXXXX}$  marks components on Parts list have special characteristics to maintain the safety performance of this unit. When replacing any of these parts, be sure to use only those specified parts.

Symbol No.	Part No.	Description
<b>Cabinet Parts</b>		
1	U704D665H02	Knob (Band Selector, Muting, Tuning)
2	L704D032G01	Knob-Assy (Att)
3	L704D033G01	Knob-Assy (Selector)
4	L704D034G01	Knob-Assy (Bass, Treble, Balance, Loudness)
5	*	Screw B-TITE L=10
6	*	Screw M3x6
7	*	Bolt M6x18
8	L712C501G01	Panel-Assy Front
9	U704D568G07	Knob-Assy (Power)
10	U704D552G16	Knob-Assy (Speakers, Filter, Tone)
12	U720B241H02	Cabinet-Amp
13	*	Base
14	*	Leg
15	*	Screw-Metal 3x12
16	*	Holder
17	*	Holder-U
18	*	Holder-U
19	*	Holder-U
20	*	Panel-Front
22	*	Nut M7
23	*	Nut M9
24	*	Shield
25	U430Y014H01	SW-Rotary (S4) (Program Selector)
26	U430Y015H01	SW-Rotary (S3) (Record Selector)
28	*	Screw-B M5x8
29	*	Screw-B
30	*	Holder
31	*	T-Screw 1-3x8
32	*	T-Screw 1-3x10
34	U704C108H02	Knob (Preset)
35	*	Holder-L
36	U582B134H05	Panel-Back
37	U542C217H01	Holder-Ant
38	*	Clamper
39	*	Bush-Mold
40	U561C066H01	Battery-Case
41	*	Screw-F M2.6x6
43	*	P.C.B.-Assy (FC-502)
44	U704C109H01	Knob (Down, Up)
45	*	T Screw 1-3x8
46	*	P.C.B.-Assy (AFT-502)
47	*	T. Screw 2-3x6
48	*	P.C.B.-Assy (PMA-22)
51	*	Holder-U
52	*	Radiator
53	*	Holder
54	*	Screw-B M4x8
55	*	Screw-B M3x14
56	U713D385G03	Ornament-Assy
57	*	Cover
58	*	Washer
59	*	T-Screw 2-3x8

Symbol No.	Part No.	Description
<b>Diode</b>		
D21	U264C025H03	GP20D
D22	U264C025H03	GP20D
D23	U264C025H03	GP20D
D24	U264C025H03	GP20D
D51	U264S005H01	ESAB03
D52	U264C012H03	MZ308B
D101	U264Y009H01	KV1320
D102	U264Y009H01	KV1320
D103	U264Y009H01	KV1320
D105	U264S011H01	DS442
D106	U264S011H01	DS442
D120	U264S011H01	DS442
D191	U264S013H30	RD6,2E-B2
D201	U264Y002H01	KV1226Y
D202	U264Y002H01	KV1226Y
D203	U264S011H01	DS442
D204	U264S011H01	DS442
D205	U264S011H01	DS442
D206	U264S011H01	DS442
D501	U264S012H01	DS446
D601	U264S012H01	DS446
D701	U264S012H01	DS446
D702	U264S012H01	DS446
D703	U264S012H01	DS446
D810	U264S011H01	DS442
D820	U264S011H01	DS442
D821	U264S011H01	DS442
D822	U264S011H01	DS442
D823	U264S011H01	DS442
D850	U264S013H30	RD-6, 2E-B2
D851	U264S013H30	RD-6, 2E-B2
D852	U264S012H01	DS446
D861	U264S011H01	DS442
D862	U264S011H01	DS442
D881	U264S011H01	DS442
D882	U264S011H01	DS442
D883	U264S011H01	DS442
D910	L268Y003H01	LT-13233A (SIGNAL)
D911	L268Y003H01	LT-13233A (SIGNAL)
D912	L268Y003H01	LT-13233A (SIGNAL)
D913	L268Y003H01	LT-13233A (SIGNAL)
D914	L268Y003H01	LT-13233A (SIGNAL)
D923	L268Y004H01	LT-13213A (FM STEREO)
D951	U264S011H01	DS442
D952	U264S011H01	DS442
D953	U264S011H01	DS442
D958	U264S011H01	DS442
D959	U264S011H01	DS442
D960	U264S011H01	DS442
D961	U264S011H01	DS442
<b>Transistor</b>		
Q51	U260P049H20	2SD330 (E)
Q52	U260S021H03	2SC2603 (F)
Q53	U260S021H03	2SC2603 (F)

\* ----- Not a stocked part.



Symbol No.	Part No.	Description
Q101	U260C151H01	2SK55 (D)
Q102	U260P034H03	2SC535 (C)
Q103	U260P027H02	2SC461 (B)
Q104	U260C151H01	2SK55 (D)
Q105	U260D080H13	2SC710 (D)
Q106	U260S022H02	2SA1115 (E)
Q107	U260S022H02	2SA1115 (E)
Q108	U260S021H06	2SC2603 (E, F)
Q109	U260S021H06	2SC2603 (E, F)
Q110	U260S021H03	2SC2603 (F)
Q111	U260S022H06	2SA1115 (E, F)
Q202	U260S021H06	2SC2603 (E, F)
Q321	U260S043H03	2SC2320L
Q322	U260S043H03	2SC2320L
Q323	U260S021H03	2SC2603 (F)
Q351	U260S021H03	2SC2603 (F)
Q352	U260S021H03	2SC2603 (F)
Q353	U260S022H03	2SA1115 (F)
Q354	U260S021H03	2SC2603 (F)
Q421	U260S043H03	2SC2320L
Q422	U260S043H03	2SC2320L
Q423	U260S021H03	2SC2603 (F)
Q451	U260S021H03	2SC2603 (F)
Q452	U260S021H03	2SC2603 (F)
Q453	U260S022H03	2SA1115 (F)
Q454	U260S021H03	2SC2603 (F)
Q501	U260S022H03	2SA1115 (F)
Q601	U260S022H03	2SA1115 (F)
Q802	U260S021H03	2SC2603 (F)
Q803	U260S022H06	2SA1115 (E, F)
Q821	U260S042H01	TA57
Q822	U260S021H06	2SC2603 (E, F)
Q823	U260S022H06	2SA1115 (E, F)
Q851	U260C164H04	2SD571 (L.K)
Q852	U260S021H03	2SC2603 (F)
Q881	U260S021H06	2SC2603 (E, F)
Q882	U260S021H06	2SC2603 (E, F)
<b>IC's</b>		
IC101	U262Y026H01	HA11225 (FM-IF AMP)
IC102	U262Y039H01	μPC587C2 (FM-MPX)
IC201	U262Y034H01	LA1245 (AM RF/OSC/MIX/IF/DET)
IC501	U262S079H01	STK-3042 MK2 (VOLTAGE AMP)
IC502	U262S049H01	STK-1039 (POWER AMP)
IC602	U262S049H01	STK-1039 (POWER AMP)
IC701	U262S037H01	HA12002 (PROTECTOR)
IC801	U262Y030H01	μPB553 (PRESCALER)
IC802	U262Y038H01	μPD1703 (PLL-SYNTHESIZER CONTROL)
IC881	U262S096H12	μPD78M12H (+12v. REGULATER)
IC903	U262P031H01	SN16889P (LED DRIVE)
<b>Electrical Parts</b>		
C21	U140S005H60	C-Caramic-500 V 103P
C22	U140S005H60	C-Caramic-500 V 103P
C23	U140S005H60	C-Caramic-500 V 103P

Symbol No.	Part No.	Description
C24	U140S005H60	C-Caramic-500 V 103P
C25	U180S014H01	C-Elect-45V 10000
C26	U180S014H01	C-Elect-45V 10000
C51	U140S005H60	C-Ceramic-500V 103P
C52	U140S005H60	C-Ceramic-500V 103P
C53	U140S005H60	C-Ceramic-500V 103P
C54	U140S005H60	C-Ceramic-500V 103P
C55	U182S022H53	C-Elect-35V 1000
C56	U182S022H70	C-Elect-50V 330
CF101	U365Y009H01	Ceramic-Filter
CF102	U365Y009H01	Ceramic-Filter
CF201	U365Y016H01	Ceramic-Filter
F11	U283S015H16	Fuse-4A-UL <span style="float: right;">▲</span>
J1	U451S013H01	Pin Jack
J2	U451S013H01	Pin Jack
J11	U451S022H01	Jack (Phones)
J12	U442S066H01	Terminal Board (SP)
J101	L449Y003H01	Socket <span style="float: right;">▲</span>
K701	U287S007H01	Relay (Phones/Speaker)
L101	U360C007H01	Coil (ANT)
L102	U361C030H02	Coil (RF)
L103	U361C013H01	Coil (RF-OSC)
L104	U351D031H11	Coil 2.2M
L501	U351D038H11	Coil
L601	U351D038H11	Coil
L801	U361S031H51	Coil
P11	U242C777H09	Power Cord <span style="float: right;">▲</span>
S1	L432D502H01	SW-Push (Band Selector, Muting, Tuning)
S3	U430S105H03	SW-Rotary (Record Selector)
S4	U430S105H03	SW-Rotary (Program Selector)
S5	U432S028H02	SW-Push (Tone Defeat)
S6	U432S096H01	SW-Push (Filter)
S11	U432D002H01	SW-Push (power) <span style="float: right;">▲</span>
S901	L432D501H01	SW-Push (Preset)
S902	L432D501H01	SW-Push (Preset)
S903	L432D501H01	SW-Push (Preset)
S904	L432D501H01	SW-Push (Preset)
S905	L432D501H01	SW-Push (Preset)
S906	L432D501H01	SW-Push (Preset)
S907	L432D501H01	SW-Push (Preset)
S908	U432S093H02	SW-Push (Memory) (D908)
S910	U432S066H01	SW-Push (Up)
S911	U432S066H01	SW-Push (Down)
T11	L350Y501H01	Trans-Power <span style="float: right;">▲</span>
T101	U364C032H01	Trans-IF
T102	U364C034H01	Trans-IF
T201	U373Y004H01	Coil-Ant
T202	U370C054H01	Coil-Osc
T203	U374Y020H01	Trans-IF
TC101	U202S002H01	VC-TRZM-7MP0 (BLU)
TC102	U202S002H01	VC-TRZM-7MP0 (BLU)
TC103	U202S002H01	VC-TRZM-7MP0 (BLU)
TC201	U202S002H04	VC-TRZM-30N750 (GRN)
TC202	U202S002H04	VC-TRZM-30N750 (GRN)
TF101	U251Y014H01	Tube-Fluor FIP7A 13A
VR101	U127P001H08	VR-Semi-B4.7k
VR301	U121D031H02	VR-WHB250k 25 (Balance)
VR303	U121S031H03	VR-W-B100k 25 (ATT)



Symbol No.	Part No.	Description
VR304	U122S032H01	VR-Quatre-B100k 25 (Loudness)
VR305	U122S032H01	VR-Quatre-B100k 25 (Loudness)
VR306	U121S032H02	VR-W-C20k 25 (Treble)
VR307	U121S032H02	VR-W-C20k 25 (Bass)
VR401	U121D031H02	VR-WHB250k 25 (Balance)
VR403	U121S031H03	VR-W-B100k 25 (ATT)
VR404	U122S032H01	VR-Quatre-B100k 25 (Loudness)
VR405	U122S032H01	VR-Quatre-B100k 25 (Loudness)
VR406	U121S032H02	VR-W-C20k 25 (Treble)
VR407	U121S032H02	VR-W-C20k 25 (Bass)
X801	U285D007H01	Crystal
Z101	U440S012H01	Terminal-Board
B101	U360C004H11	Trans-Balun

# PACKING INSTRUCTIONS

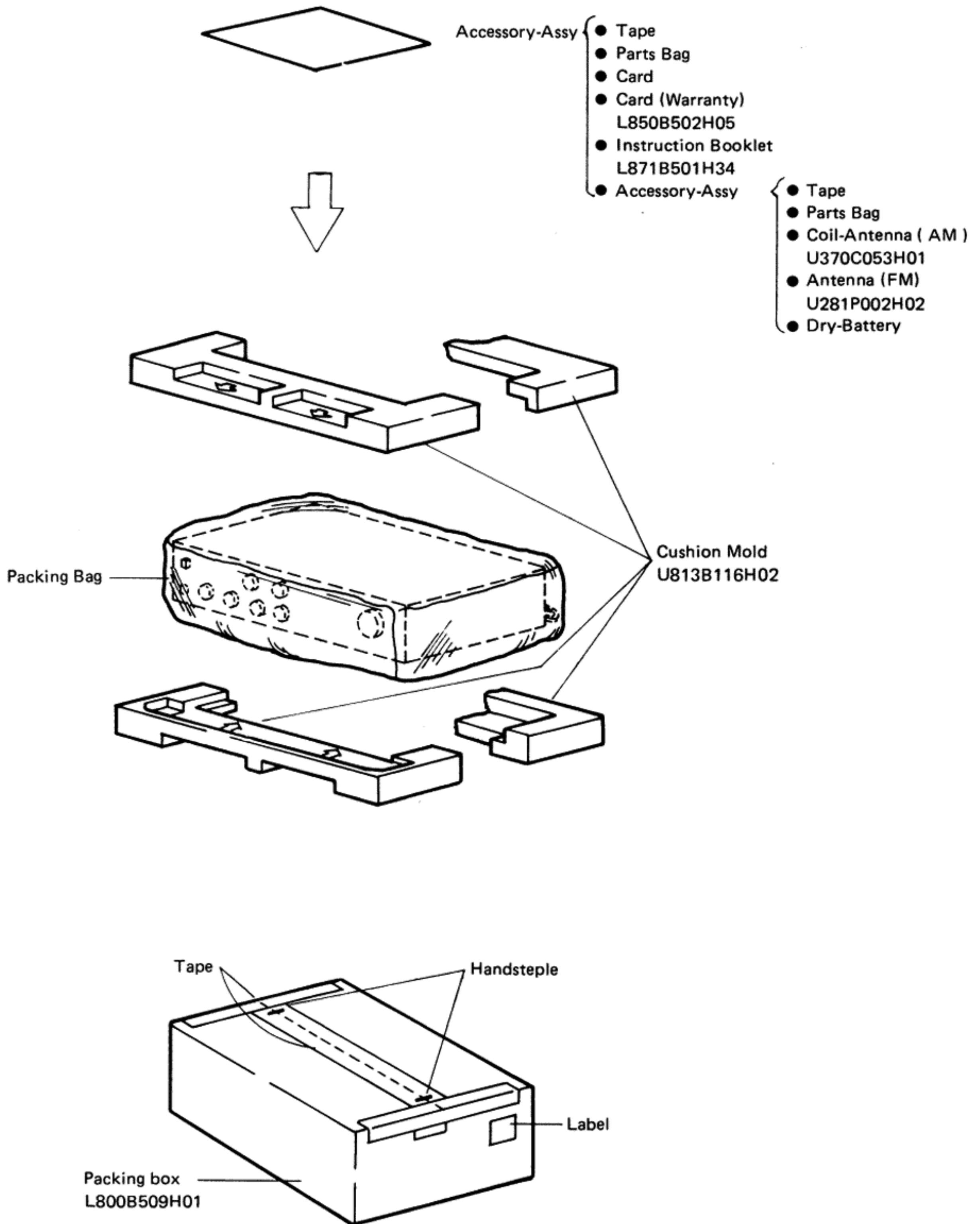

FOR TECHNICAL ASSISTANCE ON THIS PRODUCT PHONE, TOLL-FREE;

800 - 421 - 1583 \*

**MITSUBISHI ELECTRIC SALES AMERICA, INC.**

TECHNICAL SERVICES DEPARTMENT

3019 E. MARIA ST.

RANCHO DOMINGUEZ, CA. 90221

\* IN CALIFORNIA, CALL 800 - 262 - 4165

DA-R11-US  
LSM-3024  
Printed in Japan