

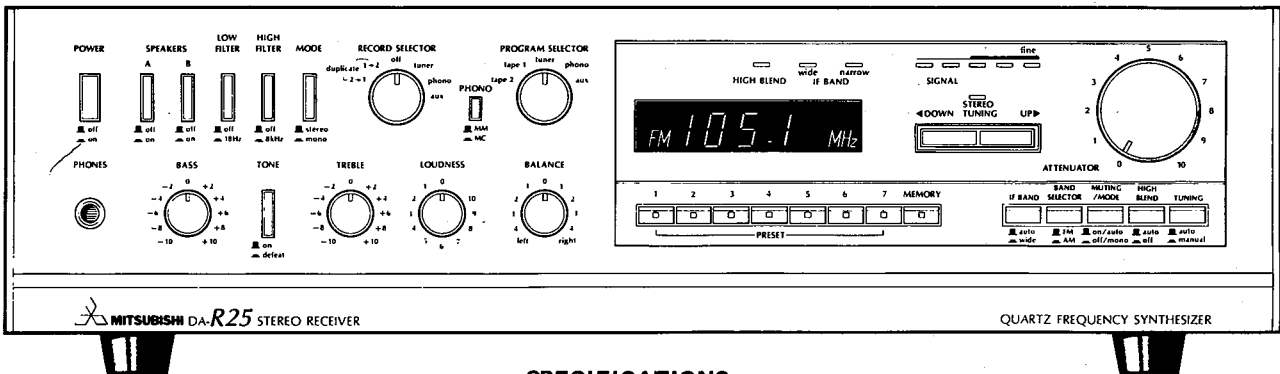

SERVICE MANUAL

STEREO RECEIVER

Model DA-R25



SPECIFICATIONS

NOTE: All measurements are for 8 ohms unless otherwise stated.

AMPLIFIER SECTION

60 watts per channel, min. RMS, both channels driven into 8 ohms from 20Hz to 20kHz with no more than 0.015% total harmonic distortion. 75 watts per channel, min. RMS both channels driven into 4 ohms from 20Hz to 20kHz with no more than 0.05% total harmonic distortion.

65 watts, into 8 ohms at 1kHz with 0.015% THD.
80 watts, into 4 ohms at 1kHz with 0.015% THD.

Input sensitivity/Impedance

PHONO MC	0.1mV/100 ohms
PHONO MM	2.5mV/50k ohms, 100PF
AUX, PLAY	150mV/50k ohms
MAIN IN	1V/50k ohms

Maximum input level

PHONO MC	20mV
PHONO MM	250mV

Output level/impedance

REC OUT 1, 2	150mV/600 ohms
--------------	----------------

Frequency response

PHONO MC	±0.3dB, 20Hz-20kHz, RIAA
PHONO MM	±0.2dB, 20Hz-20kHz, RIAA
AUX, PLAY	±0.2dB, 20Hz-20kHz
MAIN IN	±0.1dB, 20Hz-20kHz

Total harmonic distortion (20Hz-20kHz)

PHONO MC	0.005%
PHONO MM	0.005%
AUX, PLAY	0.005%
MAIN IN (half power at 8Ω)	0.005%

Signal to noise ratio

PHONO MC (500 μV)	76dB
PHONO MC (new IHF)	75dB
PHONO MM (10mV)	96dB
PHONO MM (new IHF)	78dB
AUX, PLAY (150mV)	106dB
AUX, PLAY (new IHF)	87dB
MAIN IN (new IHF)	97dB
MAIN IN (1V)	115dB

Residual noise (IHF A-weighted)

	0.1mV
--	-------

Tone control

BASS	±10dB at 100Hz
TREBLE	±10dB at 10kHz

Filters

Low	18Hz (12dB/oct)
High	8kHz (12dB/oct)

FM SECTION

Tuning range	87.9 ~ 107.9MHz
50dB quieting sensitivity	
MONO	3.0 μV (15dBf)
STEREO (Hi-Blend ON)	25 μV (33.2dBf)
Usable sensitivity	1.8 μV (10.3dBf)
Image response ratio	85dB
IF response ratio	100dB
Spurious response ratio	100dB
AM suppression ratio	60dB
Capture ratio	1.5dB
Alternate channel selectivity	
WIDE	55dB
NARROW	75dB
Signal to noise ratio	
MONO (65dBf)	82 dB (85dBf) 84dB
STEREO (65dBf)	74dB (85dBf) 78dB
Total harmonic distortion	
MONO WIDE	0.08%
NARROW	0.15%
STEREO WIDE	0.1%
NARROW	0.2%
Subcarrier product ratio	60dB
Stereo separation	
WIDE 100Hz	42dB
1kHz	46dB
10kHz	43dB
NARROW 100Hz	36dB
1kHz	40dB
10kHz	40dB
Hi-BLEND ON 100Hz	37dB
1kHz	20dB
Frequency response	
50Hz to 15kHz	±0.5dB
30Hz to 16kHz	+0.5dB ~ -1.0dB

AM SECTION

Tuning range	530 ~ 1620kHz
Usable sensitivity	300 μV/m
Selectivity	40dB
Signal to noise ratio	52dB
Image response ratio	40dB
IF response ratio	50dB
Total harmonic distortion	0.5%

GENERAL

Power consumption	210W
Dimensions (W x H x D)	470 x 135 x 436 mm (18-1/2 x 5-3/8 x 17-1/5")
Weight	12.5 kg (27.6 lbs)

Design and specifications are subject to change without notice for improvement.

MITSUBISHI ELECTRIC SALES AMERICA, INC.
3030 East Victoria Street Compton, California 90221

Back Panel

CAUTION: WHEN CONNECTING TWO PAIRS OF SPEAKERS TO THIS AMPLIFIER, ENSURE THAT THE COMBINED IMPEDANCE IS 4 OHMS OR ABOVE. THE COMBINED IMPEDANCE IS DETERMINED WITH THE FOLLOWING FORMULA.
 COMBINED IMPEDANCE = $A \times B / (A + B)$ (OHMS)
 A: NOMINAL IMPEDANCE OF SPEAKER A
 B: NOMINAL IMPEDANCE OF SPEAKER B

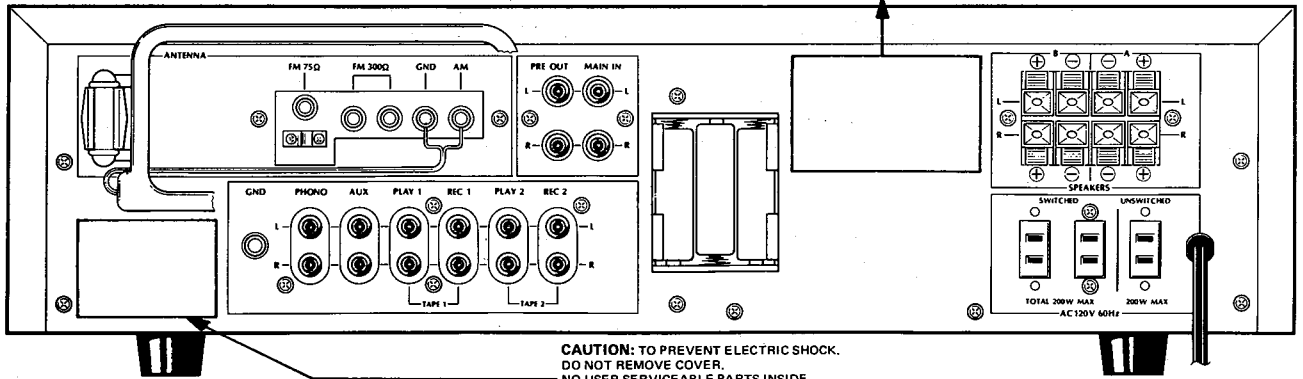

CAUTION: TO PREVENT ELECTRIC SHOCK, DO NOT REMOVE COVER. NO USER-SERVICEABLE PARTS INSIDE. REFER SERVICING TO QUALIFIED SERVICE PERSONNEL.

WARNING: TO PREVENT FIRE OR SHOCK HAZARD, DO NOT EXPOSE THIS APPLIANCE TO RAIN OR MOISTURE.

Disassembly Instructions

1. Removal of Case (Top)

Remove four screws from both sides of the case.

2. Removal of Base (Bottom)

Remove screws as shown in Figure 1.

3. Removal of Panel Assembly

Remove two screws from top face of the panel.

4. Removal of Front P.C. Board

- (1) Remove a knob and two screws as shown in Figure 2.
- (2) Remove knobs and screws as shown in Figure 3.

5. Removal of Connecting Part of Switch

To remove part (C) insert — driver in slot (A) and push part (B) out with the tip of the driver as shown in Figure 4.

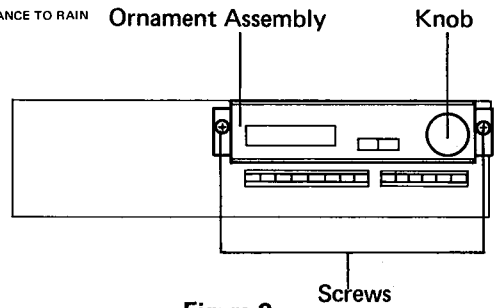

Figure 2

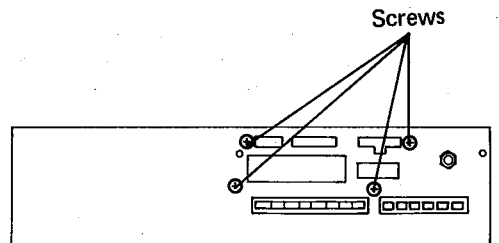

Figure 3

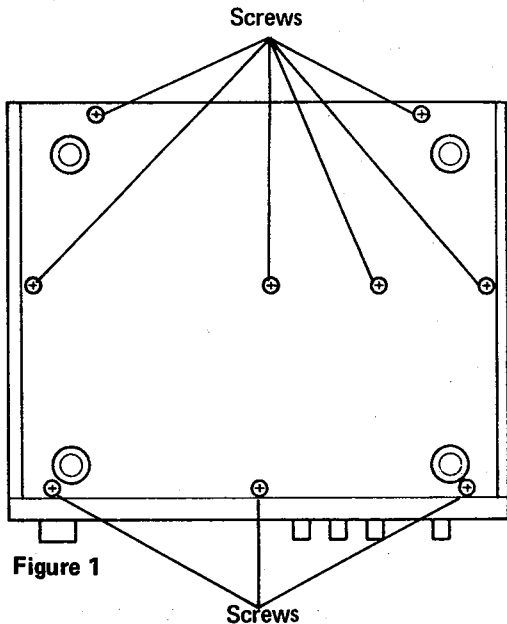

Figure 1

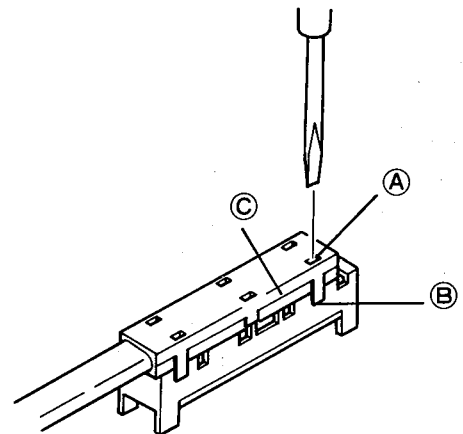
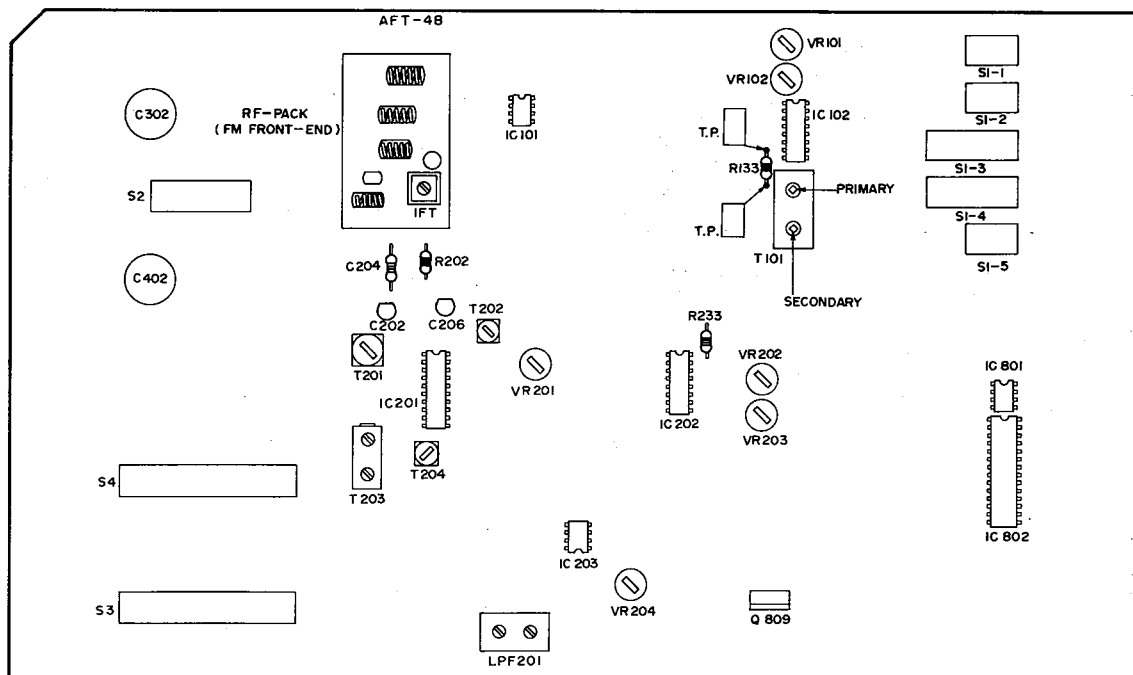

Figure 4

Adjustments



1. FM-IF

- (1) Turn off S1-1 ~ S1-5 and inject A signal of 98.1MHz, 68dBf, 1kHz and 100% modulation.
- (2) Connect a voltmeter across R133 and adjust primary of T101 for $0V \pm 50mV$.
- (3) Adjust secondary of T101 for minimum distortion. If the distortion is then above specified value, turn IFT of RF-PACK to adjust. Repeat steps 1, 2, 3 if necessary.
- (4) Set SSG output at 50dBf and adjust VR101 so that the five signal indicators light.
- (5) Adjust VR102 to that muting comes on with SSG output 25dBf and goes off with 26dBf.

2. MPX

- (1) Set SSG at 65dBf unmodulated, connect a frequency counter to the junction of R223 and VR202, and adjust VR202 for $76kHz \pm 50Hz$.
- (2) Set the pilot signal of SSG modulated stereo signal to 65dBf. Adjust VR203 for minimum pilot signal leaking with L and R balanced.
- (3) Then modulate 1kHz and adjust VR204 for maximum separation with L and R balanced.

3. AM

- (1) Turn on S1-4. Connect a voltmeter the junction of C204 and R202. Adjust C206 for $21V \pm 0.2V$ with frequency display 1620kHz and T202 for $1V \pm 0.05V$ with frequency display 530kHz. Repeat these adjustments several times.
- (2) Inject 600kHz signal and adjust T201 for maximum wave form. Inject 1400kHz signal and adjust C202 for maximum wave form. Repeat these adjustments several times.

RF-Pack

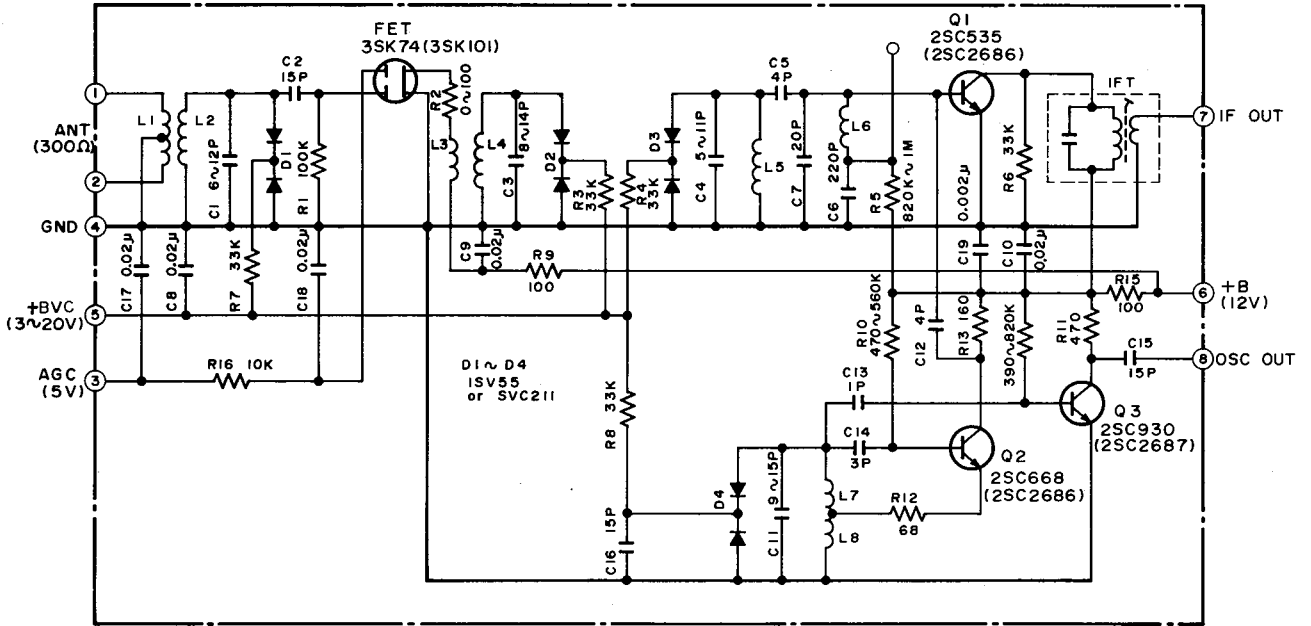

Wiring Diagram:

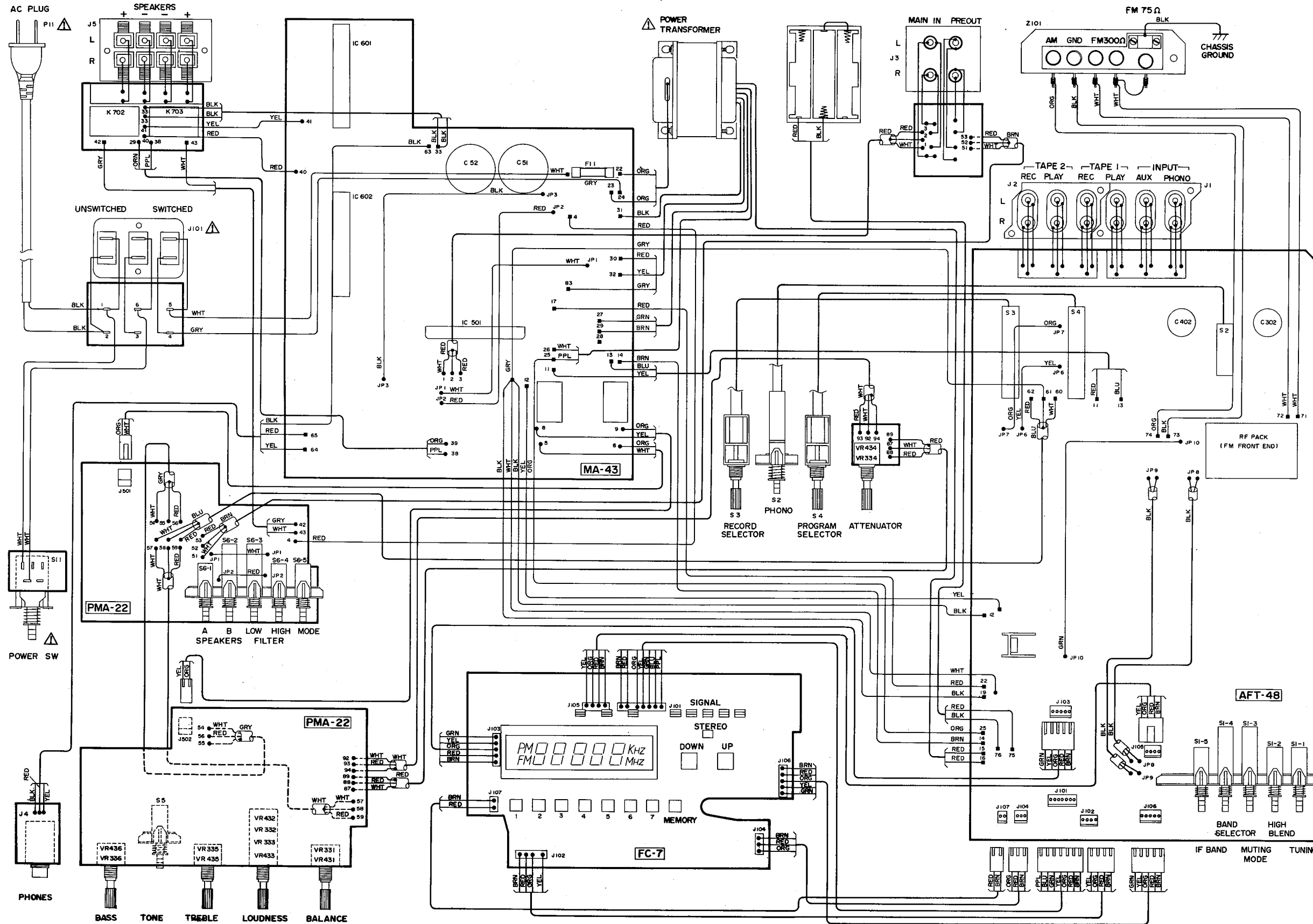

NOTE:

- The actual colors of wires may differ from those of this diagram. Wire colors are abbreviated as follows.
 BRN Brown
 PPL Purple
 GRN Green
 ORG Orange
 WHT White
 YEL Yellow
 RED Red
 GRY Gray
 BLU Blue
 BLK Black
- Parts symbolized Δ are important for the continued safety and performance of the unit. Thereafter use only the designated parts when replacing.

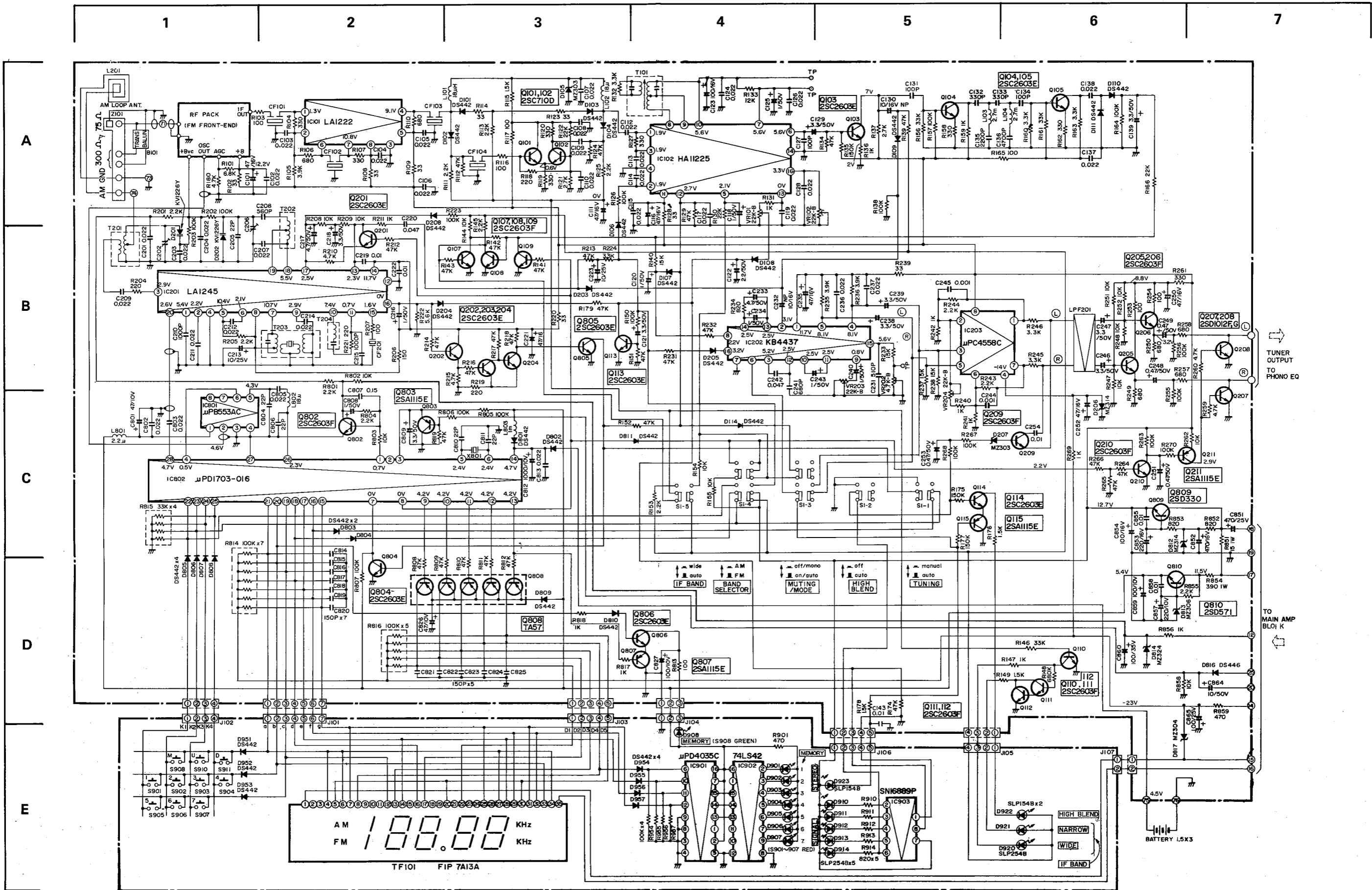

Schematic Diagram:

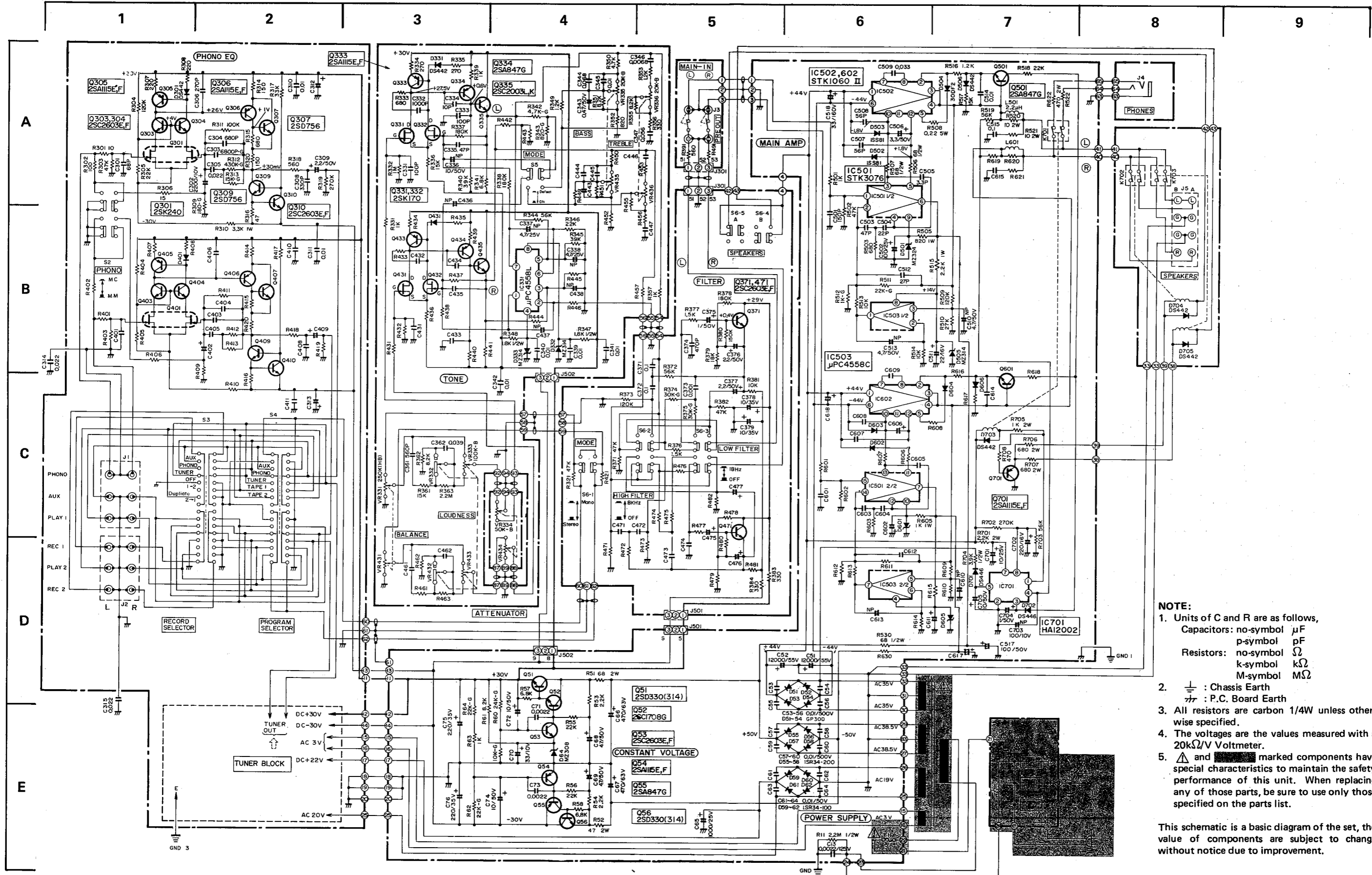

- NOTE:**
- Units of C and R are as follows,
 Capacitors: no-symbol μF
 p-symbol pF
 Resistors: no-symbol Ω
 k-symbol k Ω
 M-symbol M Ω
 - \perp : Chassis Earth
 --- : P.C. Board Earth
 - All resistors are carbon 1/4W unless otherwise specified.
 - The voltages are the values measured with a 20k Ω/V Voltmeter.
 - Δ and \blacksquare marked components have special characteristics to maintain the safety performance of this unit. When replacing any of those parts, be sure to use only those specified on the parts list.

This schematic is a basic diagram of the set, the value of components are subject to change without notice due to improvement.

Printed Circuit Boards

1

2

3

4

5

6

7

A TUNING

HI-BLEND

MODE

AM-FM

B IF-BAND

SIGNAL

C

D

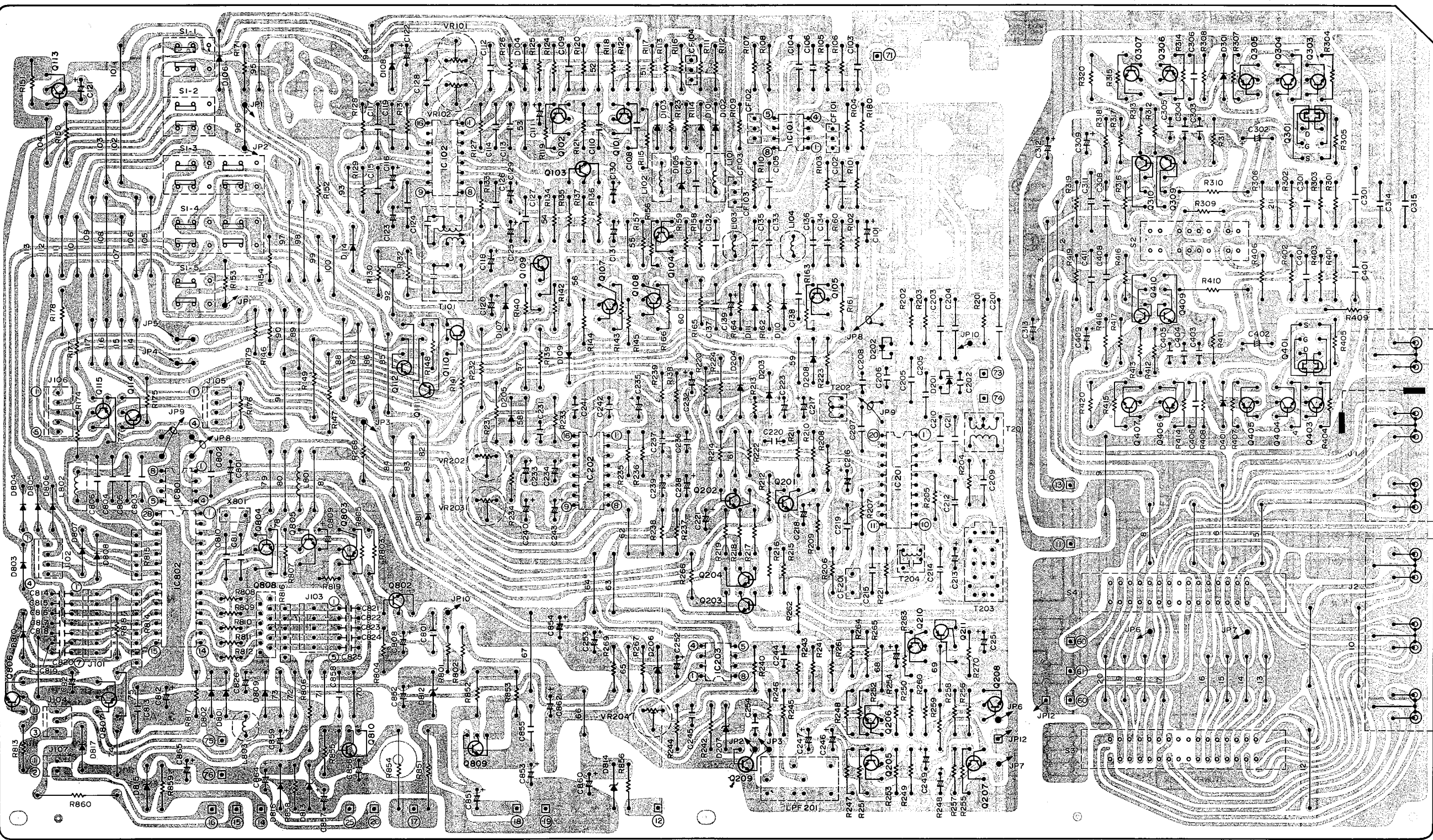

PHONO

AUX

PLAY 1

REC 1

PLAY 2

REC 2

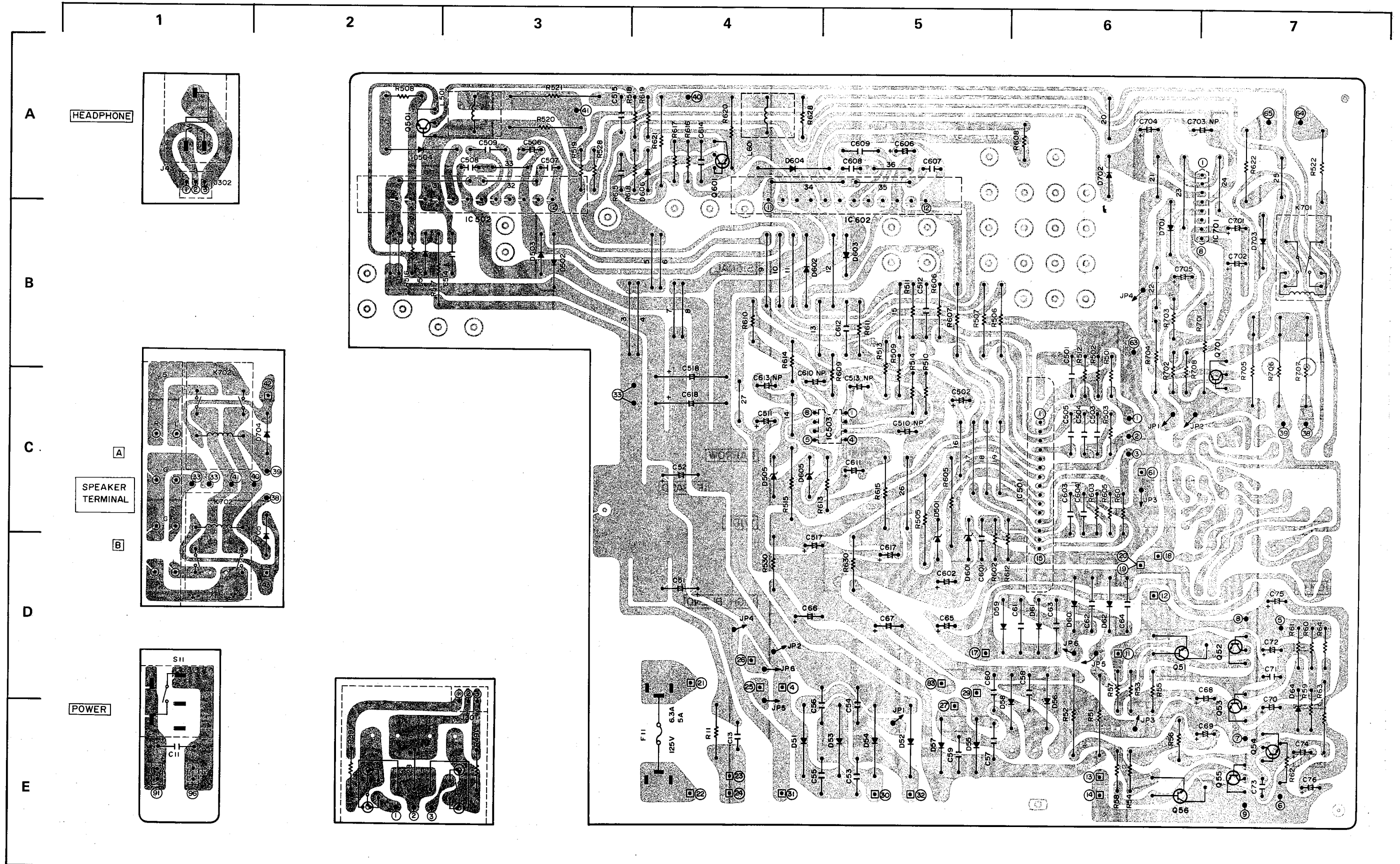

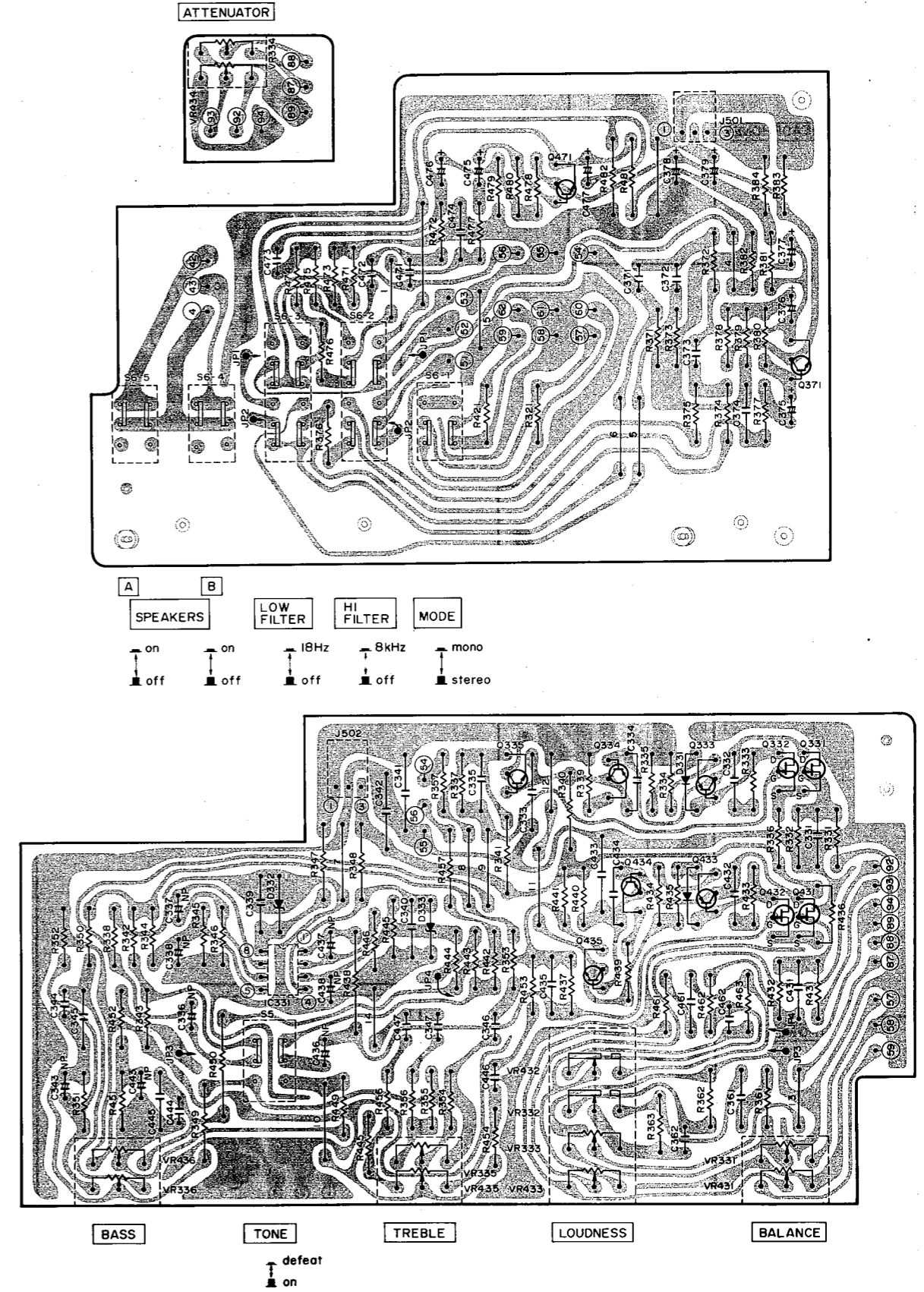
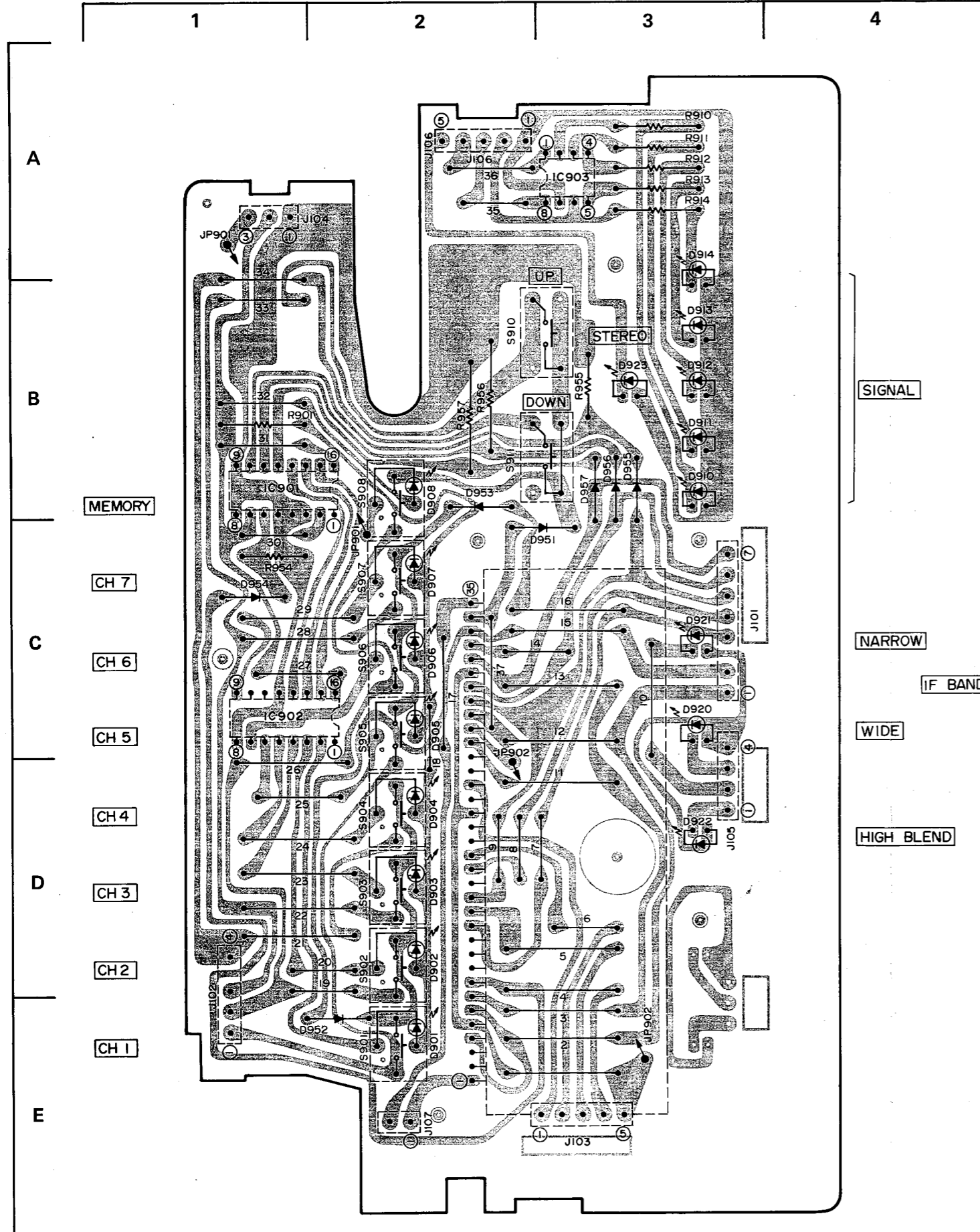

Internal Diagrams and Pinout of Integrated Circuit

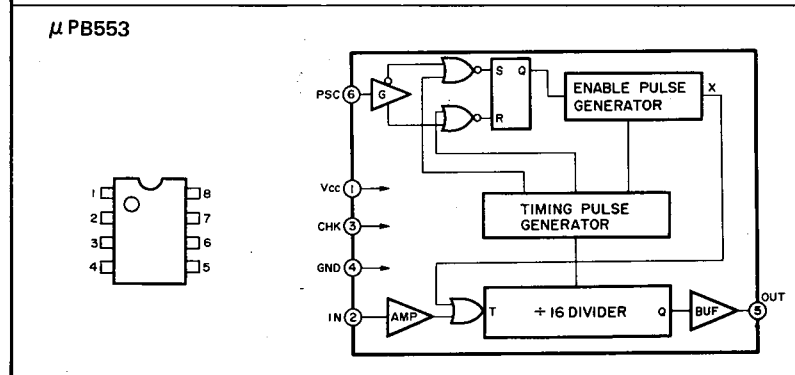
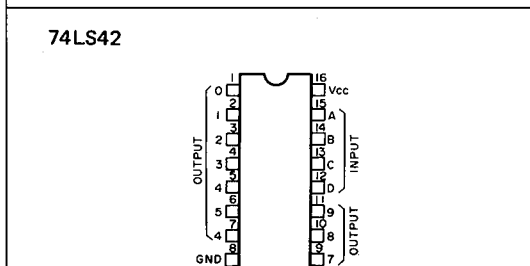
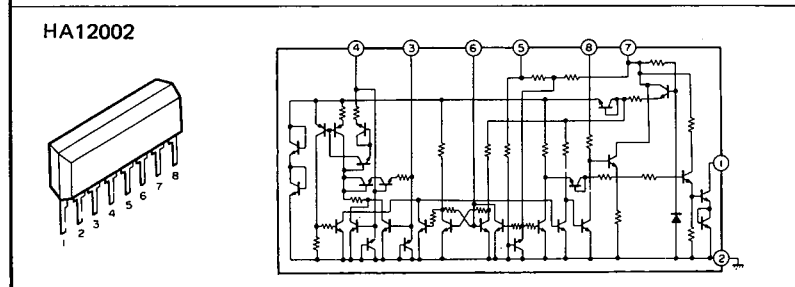
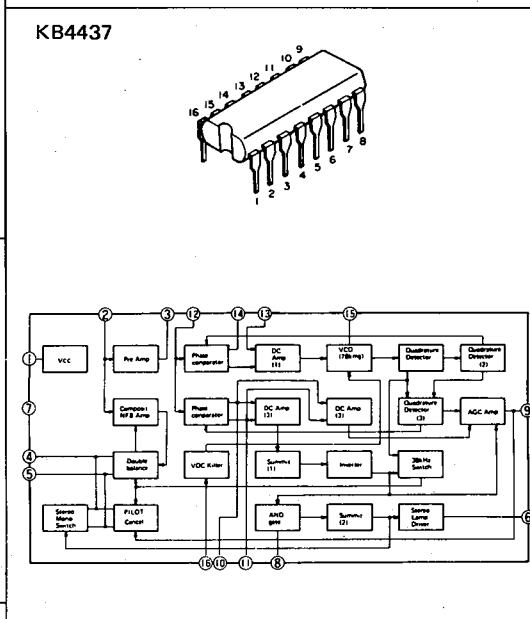
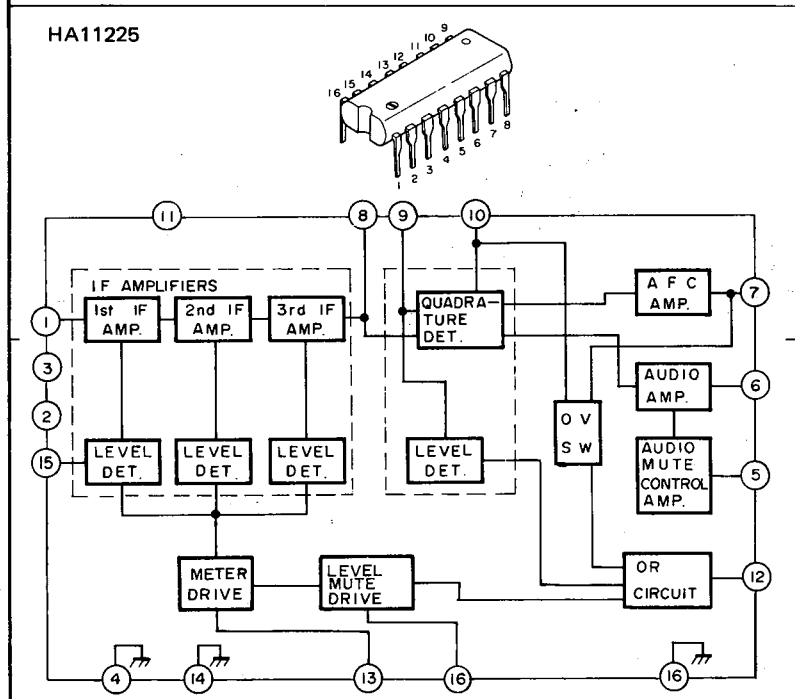
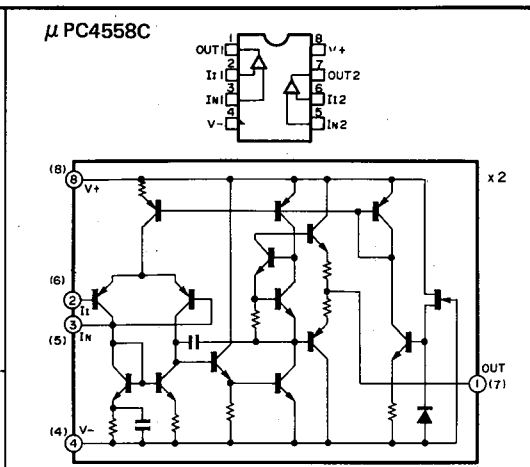
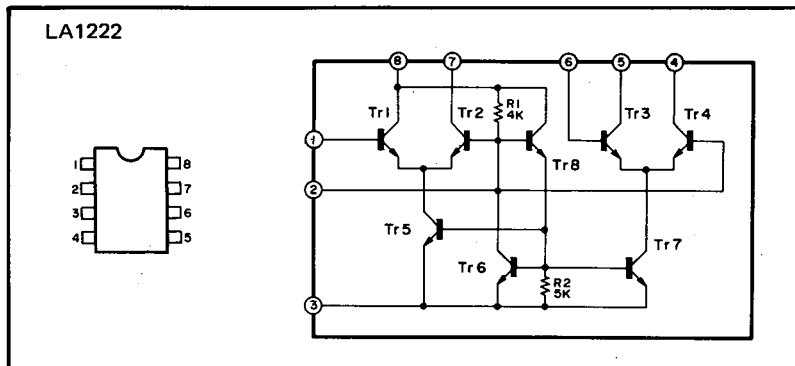

NO	D	C	B	A	0	1	2	3	4	5	6	7	8	9
0	L	L	L	L	H	H	H	H	H	H	H	H	H	H
1	L	L	L	L	H	H	H	H	H	H	H	H	H	H
2	L	L	L	L	H	H	H	H	H	H	H	H	H	H
3	L	L	L	L	H	H	H	H	H	H	H	H	H	H
4	L	L	L	L	H	H	H	H	H	H	H	H	H	H
5	L	L	L	L	H	H	H	H	H	H	H	H	H	H
6	L	L	L	L	H	H	H	H	H	H	H	H	H	H
7	L	L	L	L	H	H	H	H	H	H	H	H	H	H
8	L	L	L	L	H	H	H	H	H	H	H	H	H	H
9	L	L	L	L	H	H	H	H	H	H	H	H	H	H
10	L	L	L	L	H	H	H	H	H	H	H	H	H	H
11	L	L	L	L	H	H	H	H	H	H	H	H	H	H
12	L	L	L	L	H	H	H	H	H	H	H	H	H	H
13	L	L	L	L	H	H	H	H	H	H	H	H	H	H
14	L	L	L	L	H	H	H	H	H	H	H	H	H	H
15	L	L	L	L	H	H	H	H	H	H	H	H	H	H

STK-1060

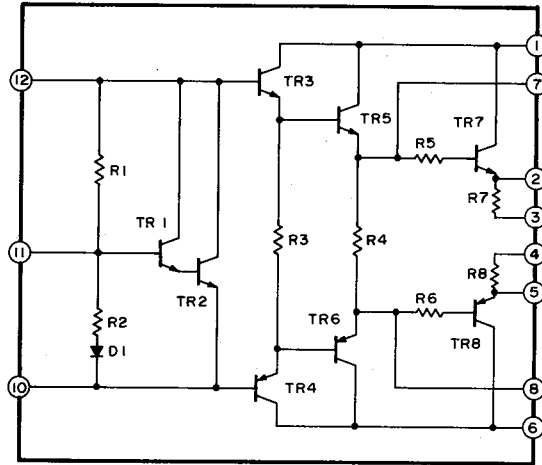
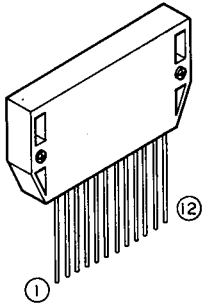

2SK240

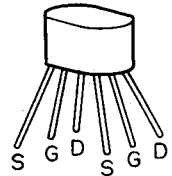

2SD571

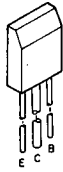

2SA1115
2SC2603
2SD756
2SK170

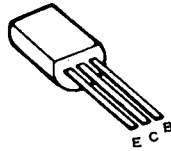

2SD330
2SD314

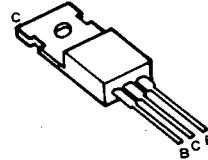

2SC710
2SC1708
2SA847

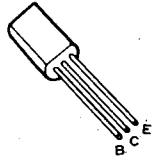

TA57

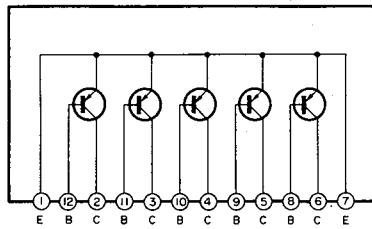
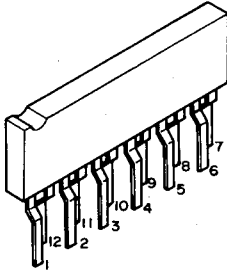

KV1226

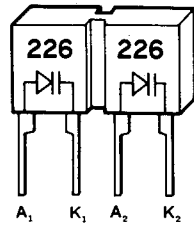

2SD1012

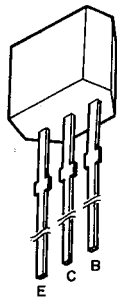

GL9PR4

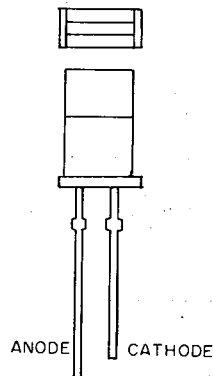

SLP-154B
SLP-254B

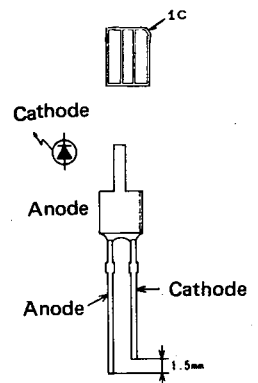

μ PD4035

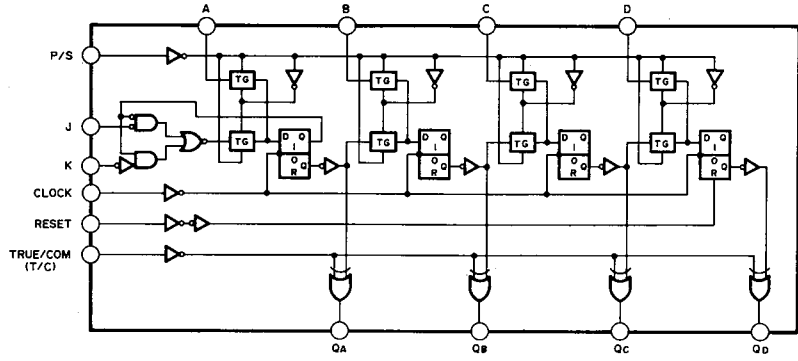
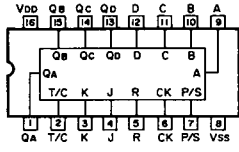

SN16889P

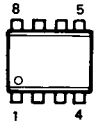

INPUT	A	O1	O2	O3	O4	O5
< 200mV	H	H	H	H	H	H
≥ 200mV	L	H	H	H	H	H
≥ 400mV	L	L	H	H	H	H
≥ 600mV	L	L	L	H	H	H
≥ 800mV	L	L	L	L	H	H
≥ 1000mV	L	L	L	L	L	H

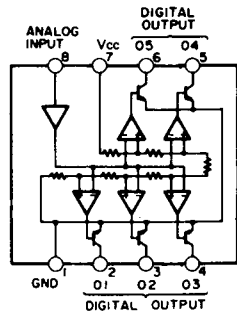

μ PD1703

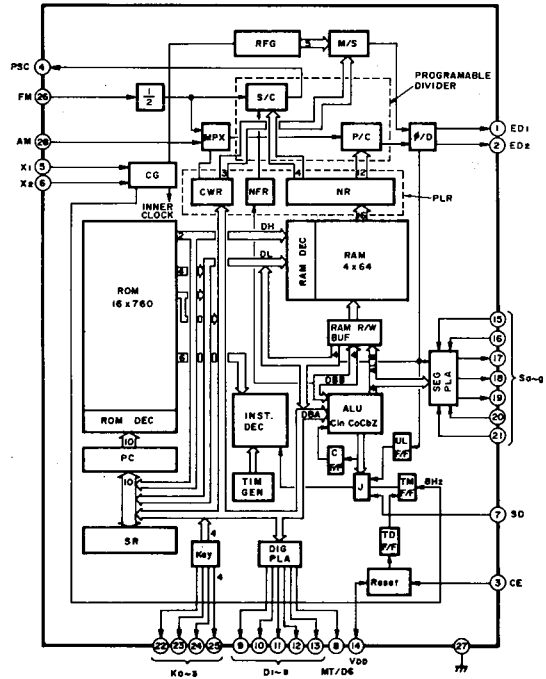
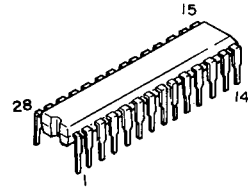

LA1245

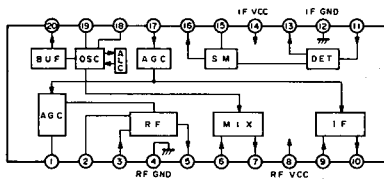
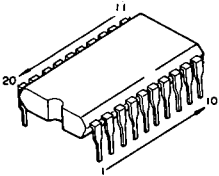

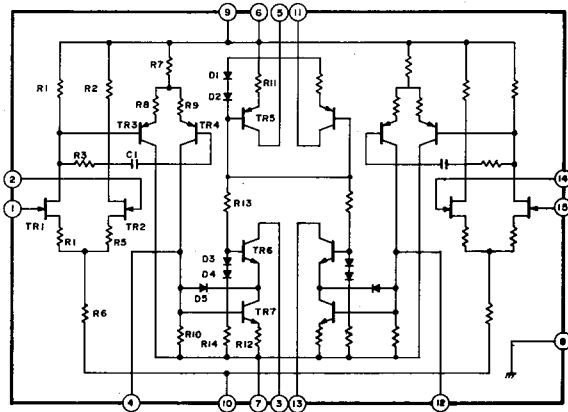
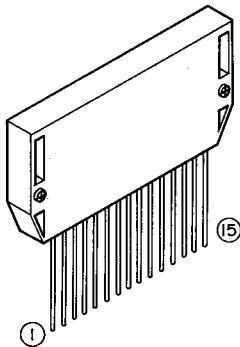

STK-3076

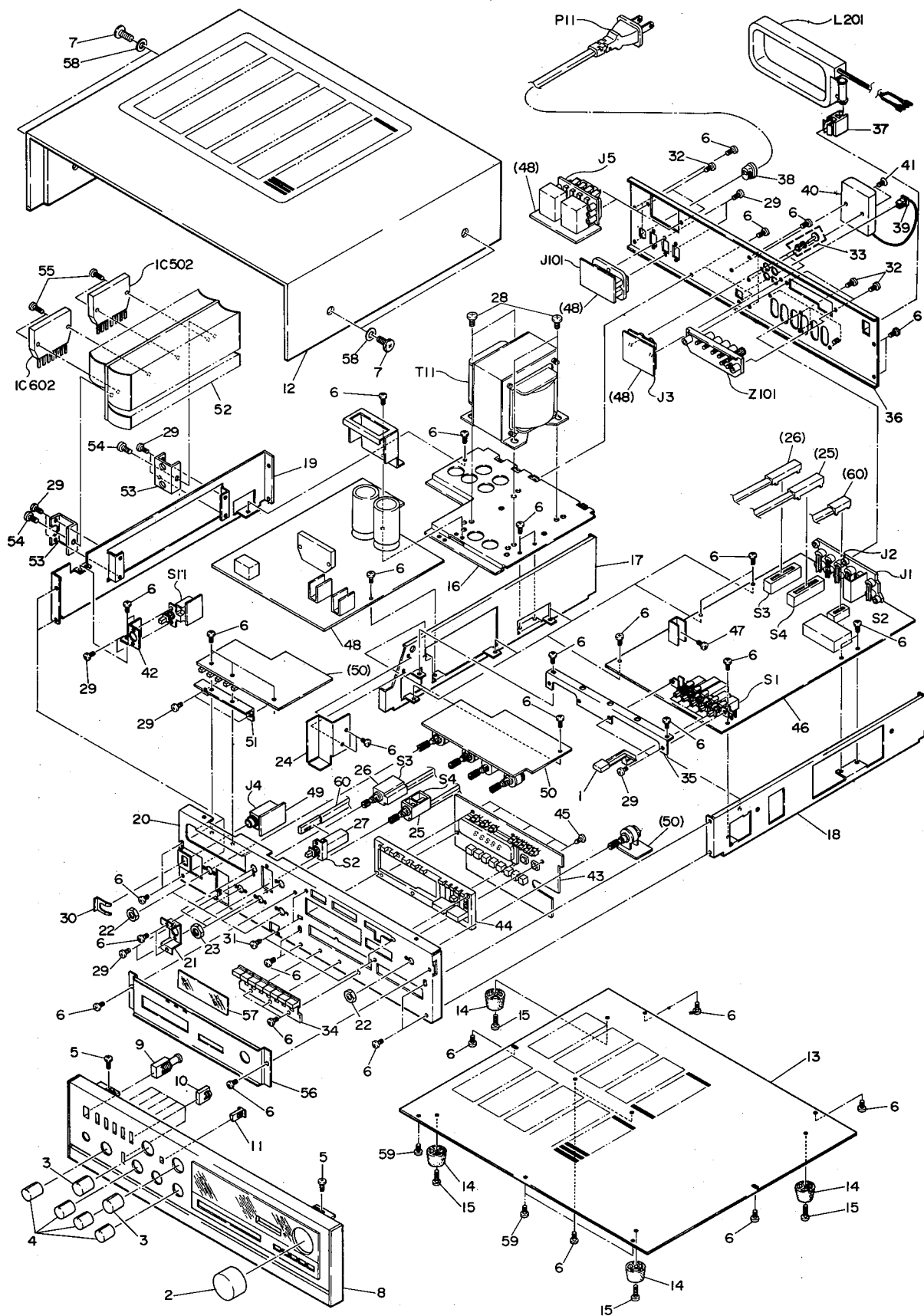

Exploded View (General)



Parts List

NOTE:  and  mark components in the Parts list that have special characteristics relating to the safe performance of this unit. When replacing any of these parts, be sure to only use the part specified.

Symbol No.	Part No.	Description
Cabinet Parts		
1	M07587200	Knob (Tuning,Hi-Blend,Mode AM-FM, IF-Band)
2	M07587201	Knob (Att)
3	M07587202	Knob (Selector)
4	M07587203	Knob (Tone)
5	*	Screw
6	*	Screw M3 x 6
7	*	Bolt M6 x 18
8	M07588100	Front Panel Assy
9	M07587204	Knob-Assy (Power)
10	M07587205	Knob-Assy (Speakers, Mode, Filters)
11	M07588200	Knob-Assy (MM-MC)
12	M07587116	Cabinet-Amp
13	*	Base
14	*	Leg
15	*	Screw-Metal 3 x 12
16	*	Holder
17	*	Holder-U
18	*	Holder-U
19	*	Holder-U
20	*	Panel-Front
21	*	Holder
22	*	Nut M7
23	*	Nut M9
24	*	Shield
25	M07587365	SW-Rotary (S4) (Program Selector)
26	M07587366	SW-Rotary (S3) (Record Selector)
27	M07571355	SW-Rotary (S2) (MM-MC)
28	*	Screw-B M5 x 8
29	*	Screw-B
30	*	Holder
31	*	T-Screw 1-3 x 8
32	*	T-Screw 1-3 x 10
33	*	Rivet-PL
34	M07587206	Knob (Preset/Memory)
35	*	Holder-L
36	M07588102	Panel-Back
37	M07556655	Holder-Ant
38	*	Clamper
39	*	Bush-Mold
40	M07587160	Battery-Case
41	*	Screw-F M2.6 x 6
42	*	Holder
43	*	P.C.B.-Assy (FC-7)
44	M07587207	Knob (UP/DOWN)
45	*	T-Screw 1-3 x 8

Symbol No.	Part No.	Description
46	*	P.C.B.-Assy (AFT-48)
47	*	T-Screw 2-3 x 6
48	*	P.C.B.-Assy (MA-43)-11
49	*	P.C.B.-Assy (MA-43)-12
50	*	P.C.B.-Assy (CTL-58)
51	*	Holder-U
52	*	Radiator
53	*	Holder
54	*	Screw-B M4 x 8
55	*	Screw-B M3 x 14
56	*	Ornament
57	*	Cover
58	*	Washer
59	*	T-Screw 2-3 x 8
60	M07588356	SW-Push (S2) (MM-MC)
Diode		
D51	M07447321	GP30D
D52	"	"
D53	"	"
D54	"	"
D55	M05147320	1SR34-200
D56	"	"
D57	"	"
D58	"	"
D59	M07391320	1SR34-100
D60	"	"
D61	"	"
D62	"	"
D64	M07493321	MZ308
D101	M07556320	DS442
D102	"	"
D103	"	"
D104	"	"
D105	M07520320	MZ303
D106	M07556320	DS442
D107	"	"
D108	"	"
D109	"	"
D110	"	"
D111	"	"
D114	"	"
D201,202	M07460322	KV1226Y
D203	M07556320	DS442
D204	"	"
D205	"	"
D206	M07514321	MZ314
D207	M07520320	MZ303
D208	M07556320	DS442
D301	"	"

* NOT A STOCKED PART

Symbol No.	Part No.	Description
D331	M07556320	DS442
D332	M07514321	MZ314
D333	"	"
D401	M07556320	DS442
D431	"	"
D501	M07288320	MZ324
D502	M07519320	1SS81
D503	"	"
D504	M07588320	30DF2
D505	M07514321	MZ314
D506	M07556320	DS442
D601	M07288320	MZ324
D602	M07519320	1SS81
D603	"	"
D604	M07588320	30DF2
D605	M07514321	MZ314
D606	M07556320	DS442
D701	M07554320	DS446
D702	"	"
D703	M07556320	DS442
D704	"	"
D705	"	"
D801	"	"
D802	"	"
D803	"	"
D804	"	"
D805	"	"
D806	"	"
D807	"	"
D808	"	"
D809	"	"
D810	"	"
D811	"	"
D812	M07514321	MZ314
D813	M07492320	MZ306
D814	M07288320	MZ324
D816	M07554320	DS446
D817	M05199320	MZ304
D910	M05179320	SLP-254B (LED)
D911	"	"
D912	"	"
D913	"	"
D914	"	"
D920	"	"
D921	M07444320	SLP-154B (LED)
D922	"	"
D923	"	"
D951	M07556320	DS442
D952	"	"
D953	"	"
D954	"	"
D955	"	"
D956	"	"

Symbol No.	Part No.	Description
D957	M07556320	DS442
Transistor		
Q51	M07240304	2SD314
Q52	M07113310	2SC1708 (G)
Q53	M07390303	2SC2603 (F)
Q54	M07390304	2SA1115 (F)
Q55	M07140303	2SA847 (G)
Q56	M07240304	2SD314
Q101	M04070304	2SC710 (D)
Q102	"	"
Q103	M07390303	2SC2603 (F)
Q104	"	"
Q105	"	"
Q107	"	"
Q108	"	"
Q109	"	"
Q110	"	"
Q111	"	"
Q112	"	"
Q113	"	"
Q114	"	"
Q115	M07390304	2SA1115 (F)
Q201	M07390303	2SC2603 (F)
Q202	"	"
Q203	"	"
Q204	"	"
Q205	"	"
Q206	"	"
Q207	M07454303	2SD1012 (G)
Q208	"	"
Q209	M07390303	2SC2603 (F)
Q210	"	"
Q211	M07390304	2SA1115 (F)
Q301	M07588300	2SK240 (BL, V)
Q303	M07390303	2SC2603 (F)
Q304	"	"
Q305	M07390304	2SA1115 (F)
Q306	"	"
Q307	M07370305	2SD756 (E)
Q309	"	"
Q310	M07390303	2SC2603 (F)
Q331	M07571300	2SK170 (BL, V)
Q332	"	"
Q333	M07390304	2SA1115 (F)
Q334	M07140303	2SA847 (G)
Q335	M07229306	2SC2003 (L)
Q371	M07390303	2SC2603 (F)
Q401	M07588300	2SK240 (BL, V)

Symbol No.	Part No.	Description
Q403	M07390303	2SC2603 (F)
Q404	"	"
Q405	M07390304	2SA1115 (F)
Q406	"	"
Q407	M07370305	2SD756 (E)
Q409	"	"
Q410	M07390303	2SC2603 (F)
Q431	M07571300	2SK170 (BL, V)
Q432	"	"
Q433	M07390304	2SA1115 (F)
Q434	M07140303	2SA847 (G)
Q435	M07229306	2SC2003 (L)
Q471	M07390303	2SC2603 (F)
Q501	M07140303	2SA847 (G)
Q601	M07140303	2SA847 (G)
Q701	M07390304	2SA1115 (F)
Q802	M07390303	2SC2603 (F)
Q803	M07390304	2SA1115 (F)
Q804	M07390303	2SC2603 (F)
Q805	"	"
Q806	"	"
Q807	M07390304	2SA1115 (F)
Q808	M07523300	TA57
Q809	M07061304	2SD330 (E)
Q810	M07228303	2SD571 (L)

IC's

IC101	M07115343	LA1222
IC102	M07465343	HA11225
IC201	M07556310	LA1245
IC202	M07461345	KB4437
IC203	M07370343	MPC4558C
IC331	"	"
IC501	M07588310	STK3076
IC502	M07588311	STK-1060-2
IC503	M07370343	MPC4558C
IC602	M07588311	STK-1060-2
IC701	M07447343	HA12002
IC801	M07510311	MPB553
IC802	M07587311	MPD1703 MOS
IC901	M07587310	MPD4035C MOS
IC902	M07510310	74LS42
IC903	M07236344	SN16889P

NOTE:

Parts marked MOS must be protected against electrostatic discharge. These parts must be handled with care.

1. Do not use glove.
2. Do not touch the leads if possible.
3. Clothing made of Nylon or other static generating material should not come in contact with these parts.
4. Work benches should have conductive tops which are grounded to an earth ground.
5. Soldering irons should be free of leakage current. Grounding is highly recommended.

Symbol No.	Part No.	Description
Electrical Parts		
C51	M07461361	C-Elect-55V12000
C52	"	"
C53	M07492360	C-Ceramic-500V103P
C54	"	"
C55	"	"
C56	"	"
C57	"	"
C58	"	"
C59	"	"
C60	"	"
C202	M07556425	VC-Trim-30N750 (Grn)
C203	"	"
C302	M05189373	C-Elect-10V2200
C402	"	"
C507	M07519432	C-Ceramic-500V56-K
C508	"	"
C607	"	"
C608	"	"
CF101	M07510446	Ceramic-Filter
CF102	"	"
CF103	"	"
CF104	M07510447	Ceramic-Filter
CF201	M07587445	Ceramic-Filter
F11	M07461492	Fuse-5A-JUL ⚠
J1	M07441576	Pin Jack (Input)
J2	"	" (")
J3	M07240475	Pin Jack (Preout, Main-in)
J4	M07571475	Jack (Phones)
J12	M07461575	Terminal Board (SP)
J101	M07320480	Socket (AC Outlet) ⚠
K701	M07504465	Relay (Phones)
K702	M07300465	Relay (Speaker-A)
K703	"	" (Speaker-B)
L101	M07132530	Coil 18 mH
L102	"	"
L103	M07510510	Coil 272J
L104	"	"
L801	M07510511	Coil 2.2 μ H
L802	M07132530	Coil 18 μ H
L803	M04167536	Coil-102J
LPF201	M07441381	Filter
P11	M07461440	Power Cord ⚠
RF	M07588540	RF-Pack
S1	M07587357	SW-Push (Tuning, Hi-Blend, Mode, AM-FM, IF-Band)
S2	M07545360	SW-Slide (MM-MC)
S3	M07461454	SW-Rotary (Record Selector)
S4	"	" (Program Selector)
S5	M07461452	SW-Push (Tone Defeat)
S6	M07588355	SW-Push (Filter, Mode, Speakers)

Symbol No.	Part No.	Description
S901	M07587355	SW-Push (Preset)
S902	"	"
S903	M07587355	"
S904	"	"
S905	"	"
S906	"	"
S907	"	"
S910	M07520454	SW-Push (Up)
S911	M07520454	SW-Push (Down)
T101	M07514510	Trans-IF
T201	M07556513	Coil-Ant
T202	M07556511	Coil-Osc
T203	M07587502	Trans-IF
T204	M07587503	Trans-IF
TF101	M07520555	Tube-Fluor FIP7A 13A

Symbol No.	Part No.	Description
VR101	M07141351	VR-Semi-B22K
VR102		
VR202	M07115352	VR-Semi-B4.7K
VR203	M07141351	VR-Semi-B22K
VR204		
VR331,431	M07426401	VR-W-HB250K25
VR332,432	M07461400	VR-Quatre-B100K25
VR333,433		
VR334,434	M07588400	VR-W-B50K25
VR335,435	M07461401	VR-W-C20K25
VR336,436		
X801	M07510345	Crystal
Z101	M07546480	Terminal-Board

Designation of Parts "C", "R", "H" & "VR" (Example)

- C (Capacitor)**
 - C-Ceramic-500V 103P
 - Description: C-Ceramic
 - Voltage: 500V
 - Value: $10 \times 10^3 = 10,000 \text{ pF} = 0.01 \mu\text{F}$
 - Tolerance Symbol: P
 - C-ELECT-45V 10000
 - Description: C-ELECT
 - Voltage: 45V
 - Value: 10,000 μF
- R (Resistor)**
 - R-FUSE-1/2W 22-K
 - Description: R-FUSE
 - Wattage: 1/2W
 - Value: 22 Ω
 - Tolerance Symbol: K
- H (Inductor)**
 - COIL 223J
 - Description: COIL
 - Value: $22 \times 10^3 = 22,000 \mu\text{H} = 2.2\text{mH}$
 - Tolerance Symbol: J
- VR (Variable Resistor)**
 - VR-SEME-B22K
 - Description: VR-SEME
 - Variable Characteristic: Semi-fixed
 - Maximum Resistance Value: 22K Ω
 - VR-Quatre-B100K25
 - Description: VR-Quatre
 - Variable Characteristic: Four Coupling VR
 - Maximum Resistance Value: 100K Ω
 - Shaft length (mm): 25mm
 - VR-W-C20K25
 - Description: VR-W
 - Variable Characteristic: Two Coupling VR
 - Maximum Resistance Value: 20K Ω
 - Shaft Length (mm): 25mm

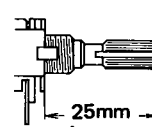

MEMO:

Packing Instruction

