

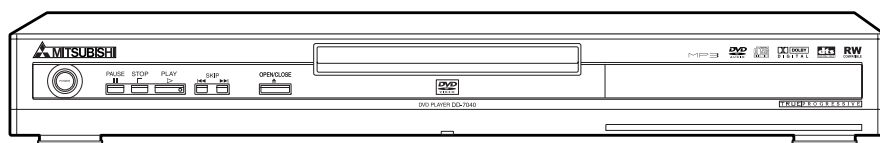

# Service Manual

DVD PLAYER



MODEL

**DD-7040**

## TABLE OF CONTENTS

SPECIFICATIONS .....	1-1-1
LASER BEAM SAFETY PRECAUTIONS .....	1-2-1
IMPORTANT SAFETY PRECAUTIONS .....	1-3-1
STANDARD NOTES FOR SERVICING .....	1-4-1
OPERATING CONTROLS AND FUNCTIONS .....	1-5-1
CABINET DISASSEMBLY INSTRUCTIONS .....	1-6-1
BLOCK DIAGRAMS .....	1-7-1
SCHEMATIC DIAGRAMS / CBA'S AND TEST POINTS .....	1-8-1
WAVEFORMS .....	1-9-1
WIRING DIAGRAM .....	1-10-1
FIRMWARE RENEWAL MODE .....	1-11-1
SYSTEM CONTROL TIMING CHARTS .....	1-12-1
IC PIN FUNCTION DESCRIPTIONS .....	1-13-1
LEAD IDENTIFICATIO .....	1-14-1
EXPLODED VIEWS .....	1-15-1
MECHANICAL PARTS LIST .....	1-16-1
ELECTRICAL PARTS LIST .....	1-17-1

# MITSUBISHI ELECTRIC

MITSUBISHI DIGITAL ELECTRONICS AMERICA, INC.

9351 Jeronimo Road, Irvine, CA 92618-1904

Copyright © 2003 Mitsubishi Digital Electronics America, Inc.

All Rights Reserved

Manufactured under license from Dolby Laboratories. "Dolby"  
and the double-D symbol are trademarks of Dolby Laboratories.

# SPECIFICATIONS

ITEM	CONDITIONS	UNIT	NOMINAL	LIMIT
1. Video Output	75 ohm load	Vpp	1.0	± 0.1
2. Optical Digital Out		dBm	-18	
3. Audio (PCM)				
3-1. Output Level	1kHz 0dB	Vrms	2.0	
3-2. S/N		dB	120	
3-3. Freq. Response				
DVD	fs=48kHz 20~22kHz	dB	± 0.5	
CD	fs=44.1kHz 20~20 kHz	dB	± 0.5	
3-4. THD+N				
DVD	1 kHz 0dB	%	0.0025	
CD	1 kHz 0dB	%	0.003	

**NOTES:**

1. All Items are measured without pre-emphasis unless otherwise specified.
2. Power supply : AC120 V 60 Hz
3. Load imp. : 100 K ohm
4. Room ambient : 5 °C ~ 40 °C

# LASER BEAM SAFETY PRECAUTIONS

This DVD player uses a pickup that emits a laser beam.

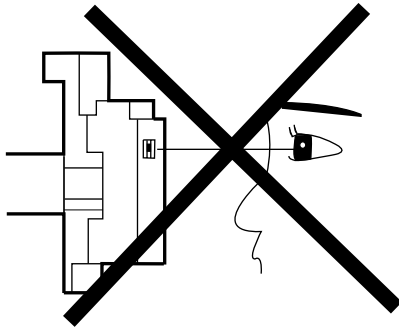

**Do not look directly at the laser beam coming from the pickup or allow it to strike against your skin.**

The laser beam is emitted from the location shown in the figure. When checking the laser diode, be sure to keep your eyes at least 30cm away from the pickup lens when the diode is turned on. Do not look directly at the laser beam.

**Caution:** Use of controls and adjustments, or doing procedures other than those specified herein, may result in hazardous radiation exposure.

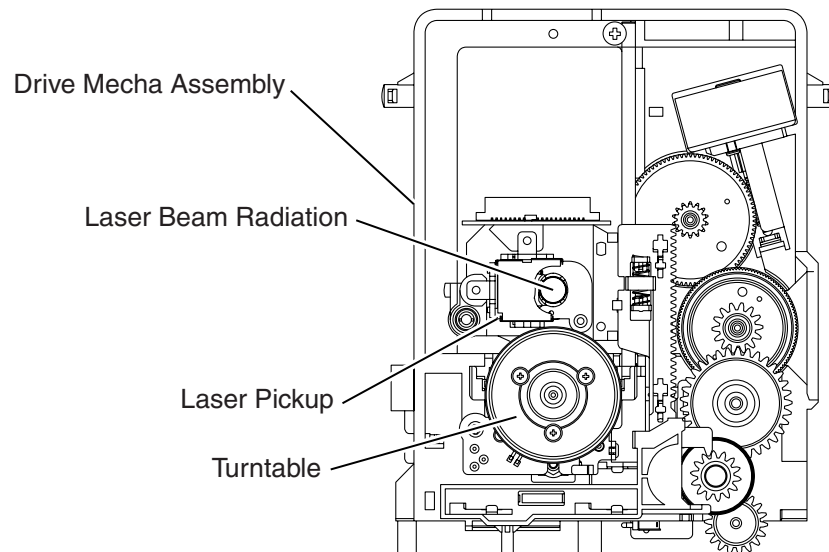

**CAUTION**  
LASER RADIATION  
WHEN OPEN. DO NOT  
STARE INTO BEAM.

**Location: Inside Top of DVD mechanism.**

# IMPORTANT SAFETY PRECAUTIONS

## Product Safety Notice

Some electrical and mechanical parts have special safety-related characteristics which are often not evident from visual inspection, nor can the protection they give necessarily be obtained by replacing them with components rated for higher voltage, wattage, etc. Parts that have special safety characteristics are identified by a **▲** on schematics and in parts lists. Use of a substitute replacement that does not have the same safety characteristics as the recommended replacement part might create shock, fire, and/or other hazards. The Product's Safety is under review continuously and new instructions are issued whenever appropriate. Prior to shipment from the factory, our products are carefully inspected to confirm with the recognized product safety and electrical codes of the countries in which they are to be sold. However, in order to maintain such compliance, it is equally important to implement the following precautions when a set is being serviced.

## Precautions during Servicing

- A.** Parts identified by the **▲** symbol are critical for safety. Replace only with part number specified.
- B.** In addition to safety, other parts and assemblies are specified for conformance with regulations applying to spurious radiation. These must also be replaced only with specified replacements.  
Examples: RF converters, RF cables, noise blocking capacitors, and noise blocking filters, etc.
- C.** Use specified internal wiring. Note especially:
  - 1) Wires covered with PVC tubing
  - 2) Double insulated wires
  - 3) High voltage leads
- D.** Use specified insulating materials for hazardous live parts. Note especially:
  - 1) Insulation tape
  - 2) PVC tubing
  - 3) Spacers
  - 4) Insulators for transistors
- E.** When replacing AC primary side components (transformers, power cord, etc.), wrap ends of wires securely about the terminals before soldering.
- F.** Observe that the wires do not contact heat producing parts (heatsinks, oxide metal film resistors, fusible resistors, etc.).
- G.** Check that replaced wires do not contact sharp edges or pointed parts.
- H.** When a power cord has been replaced, check that 5 - 6 kg of force in any direction will not loosen it.
- I.** Also check areas surrounding repaired locations.
- J.** Be careful that foreign objects (screws, solder droplets, etc.) do not remain inside the set.
- K.** Crimp type wire connector  
The power transformer uses crimp type connectors which connect the power cord and the primary side of the transformer. When replacing the transformer, follow these steps carefully and precisely to prevent shock hazards.  
Replacement procedure
  - 1) Remove the old connector by cutting the wires at a point close to the connector.  
**Important:** Do not re-use a connector. (Discard it.)
  - 2) Strip about 15 mm of the insulation from the ends of the wires. If the wires are stranded, twist the strands to avoid frayed conductors.
  - 3) Align the lengths of the wires to be connected. Insert the wires fully into the connector.
  - 4) Use a crimping tool to crimp the metal sleeve at its center. Be sure to crimp fully to the complete closure of the tool.
- L.** When connecting or disconnecting the internal connectors, first, disconnect the AC plug from the AC outlet.

## Safety Check after Servicing

Examine the area surrounding the repaired location for damage or deterioration. Observe that screws, parts, and wires have been returned to their original positions. Afterwards, do the following tests and confirm the specified values to verify compliance with safety standards.

### 1. Clearance Distance

When replacing primary circuit components, confirm specified clearance distance ( $d$ ) and ( $d'$ ) between soldered terminals, and between terminals and surrounding metallic parts. (See Fig. 1)

**Table 1: Ratings for selected area**

AC Line Voltage	Clearance Distance ( $d$ ) ( $d'$ )
120 V	$\geq 3.2\text{mm}$ (0.126 inches)

**Note:** This table is unofficial and for reference only.  
Be sure to confirm the precise values.

### 2. Leakage Current Test

Confirm the specified (or lower) leakage current between B (earth ground, power cord plug prongs) and externally exposed accessible parts (RF terminals, antenna terminals, video and audio input and output terminals, microphone jacks, earphone jacks, etc.) is lower than or equal to the specified value in the table below.

#### Measuring Method (Power ON) :

Insert load Z between B (earth ground, power cord plug prongs) and exposed accessible parts. Use an AC voltmeter to measure across the terminals of load Z. See Fig. 2 and the following table.

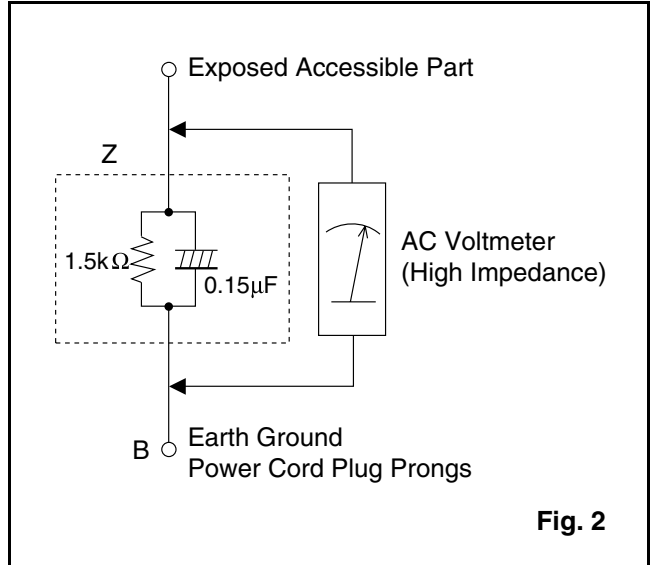
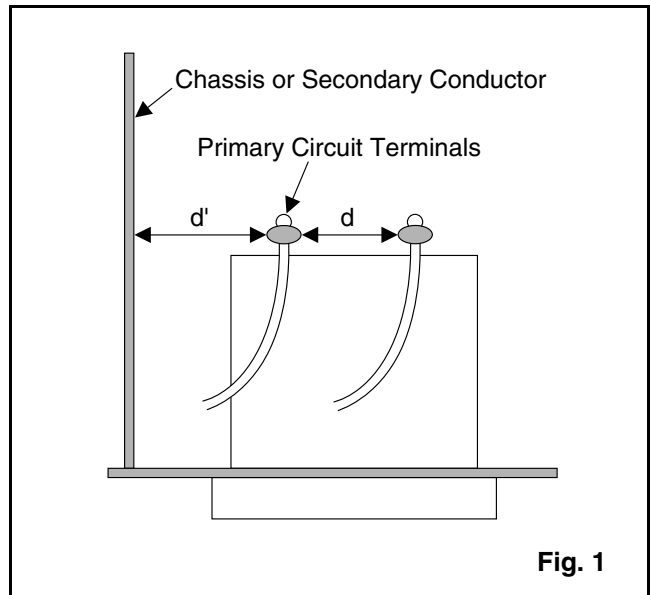

**Table 2: Leakage current ratings for selected areas**

AC Line Voltage	Load Z	Leakage Current ( $i$ )	Earth Ground (B) to:
120 V	0.15 $\mu\text{F}$ CAP. & 1.5k $\Omega$ RES. Connected in parallel	$i \leq 0.5\text{mA}$ Peak	Exposed accessible parts

**Note:** This table is unofficial and for reference only. Be sure to confirm the precise values.

# STANDARD NOTES FOR SERVICING

## Circuit Board Indications

1. The output pin of the 3 pin Regulator ICs is indicated as shown.

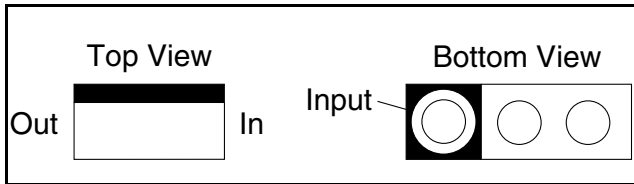

2. For other ICs, pin 1 and every fifth pin are indicated as shown.

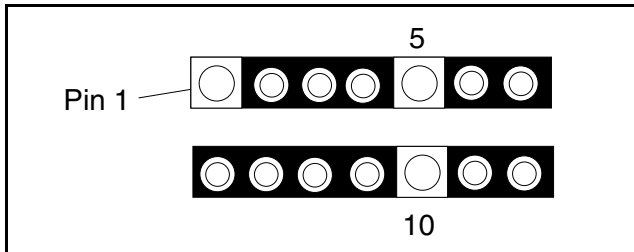

3. The 1st pin of every male connector is indicated as shown.

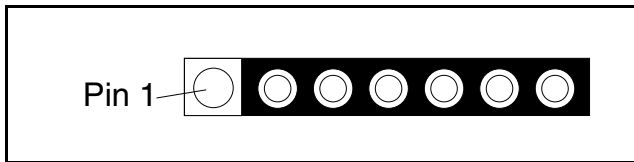

## Instructions for Connectors

1. When you connect or disconnect the FFC (Flexible Foil Connector) cable, be sure to first disconnect the AC cord.
2. FFC (Flexible Foil Connector) cable should be inserted parallel into the connector, not at an angle.

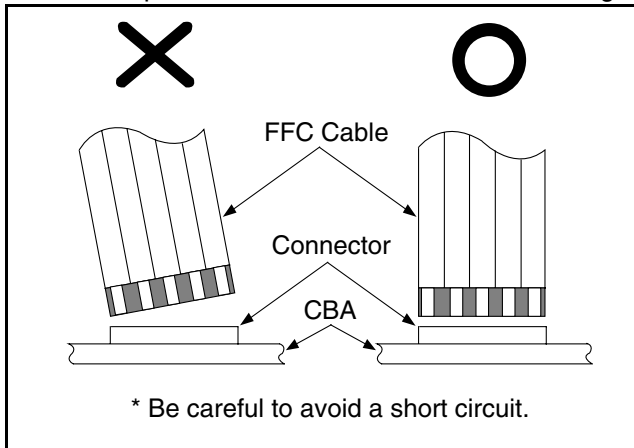

## How to Remove / Install Flat Pack-IC

### 1. Removal

**With Hot-Air Flat Pack-IC Desoldering Machine:**

- (1) Prepare the hot-air flat pack-IC desoldering machine, then apply hot air to the Flat Pack-IC (about 5 to 6 seconds). (Fig. S-1-1)

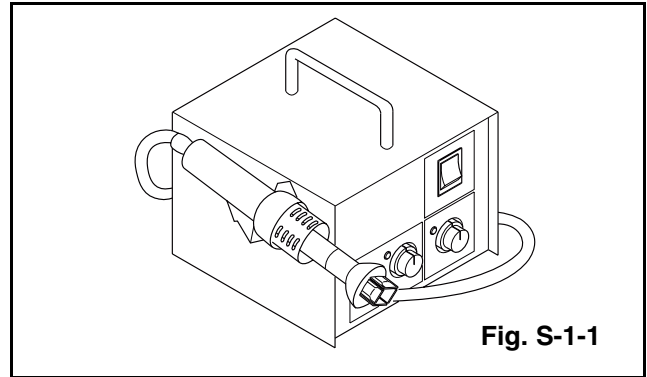

- (2) Remove the flat pack-IC with tweezers while applying the hot air.
- (3) Bottom of the flat pack-IC is fixed with glue to the CBA; when removing entire flat pack-IC, first apply soldering iron to center of the flat pack-IC and heat up. Then remove (glue will be melted). (Fig. S-1-6)
- (4) Release the flat pack-IC from the CBA using tweezers. (Fig. S-1-6)

### Caution:

1. Do not supply hot air to the chip parts around the flat pack-IC for over 6 seconds because damage to the chip parts may occur. Put masking tape around the flat pack-IC to protect other parts from damage. (Fig. S-1-2)
2. The flat pack-IC on the CBA is affixed with glue, so be careful not to break or damage the foil of each pin or the solder lands under the IC when removing it.

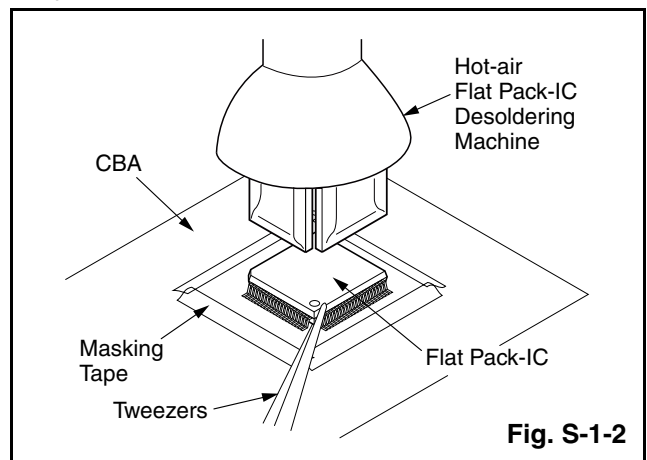

**With Soldering Iron:**

- (1) Using desoldering braid, remove the solder from all pins of the flat pack-IC. When you use solder flux which is applied to all pins of the flat pack-IC, you can remove it easily. (Fig. S-1-3)

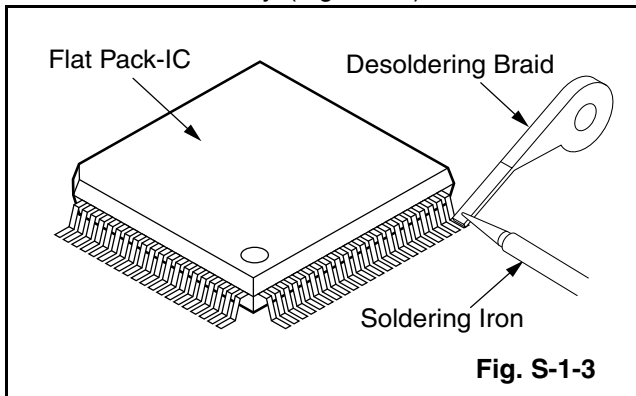

- (2) Lift each lead of the flat pack-IC upward one by one, using a sharp pin or wire to which solder will not adhere (iron wire). When heating the pins, use a fine tip soldering iron or a hot air desoldering machine. (Fig. S-1-4)

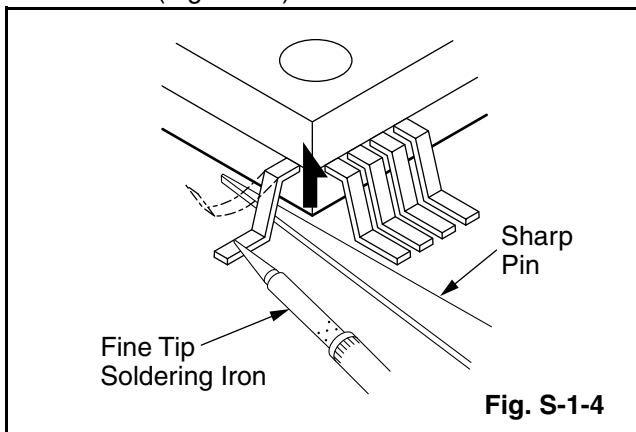

- (3) Bottom of the flat pack-IC is fixed with glue to the CBA; when removing entire flat pack-IC, first apply soldering iron to center of the flat pack-IC and heat up. Then remove (glue will be melted). (Fig. S-1-6)

- (4) Release the flat pack-IC from the CBA using tweezers. (Fig. S-1-6)

**With Iron Wire:**

- (1) Using desoldering braid, remove the solder from all pins of the flat pack-IC. When you use solder flux which is applied to all pins of the flat pack-IC, you can remove it easily. (Fig. S-1-3)

- (2) Affix the wire to a workbench or solid mounting point, as shown in Fig. S-1-5.

- (3) While heating the pins using a fine tip soldering iron or hot air blower, pull up the wire as the solder melts so as to lift the IC leads from the CBA contact pads as shown in Fig. S-1-5

- (4) Bottom of the flat pack-IC is fixed with glue to the CBA; when removing entire flat pack-IC, first apply soldering iron to center of the flat pack-IC and heat up. Then remove (glue will be melted). (Fig. S-1-6)

- (5) Release the flat pack-IC from the CBA using tweezers. (Fig. S-1-6)

**Note:**

When using a soldering iron, care must be taken to ensure that the flat pack-IC is not being held by glue. When the flat pack-IC is removed from the CBA, handle it gently because it may be damaged if force is applied.

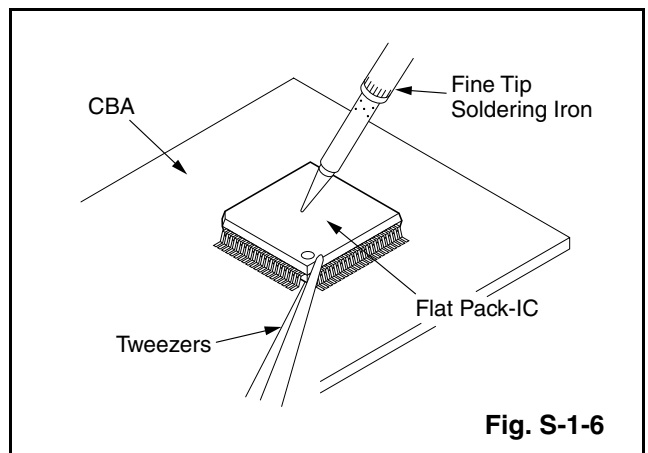
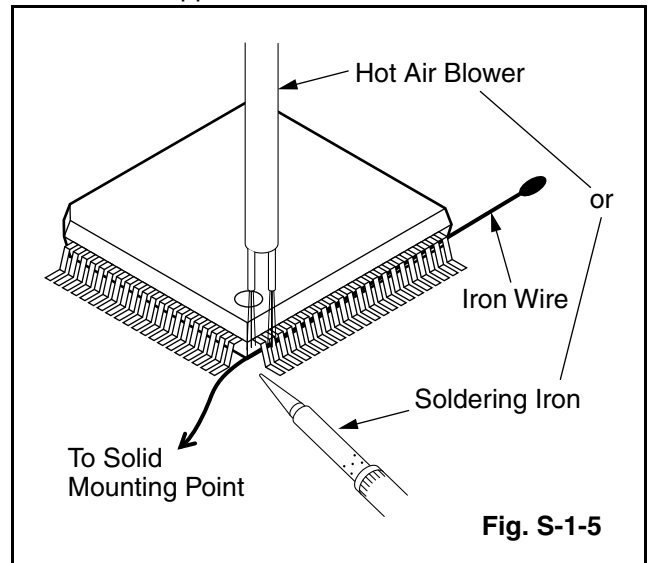



## 2. Installation

- (1) Using desoldering braid, remove the solder from the foil of each pin of the flat pack-IC on the CBA so you can install a replacement flat pack-IC more easily.
- (2) The "●" mark on the flat pack-IC indicates pin 1. (See Fig. S-1-7.) Be sure this mark matches the 1 on the PCB when positioning for installation. Then presolder the four corners of the flat pack-IC. (See Fig. S-1-8.)
- (3) Solder all pins of the flat pack-IC. Be sure that none of the pins have solder bridges.

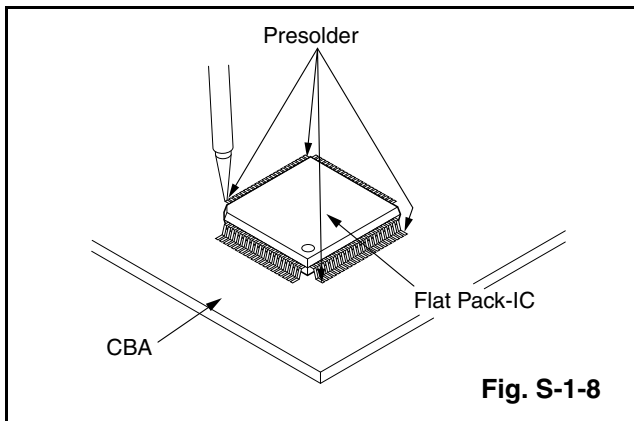
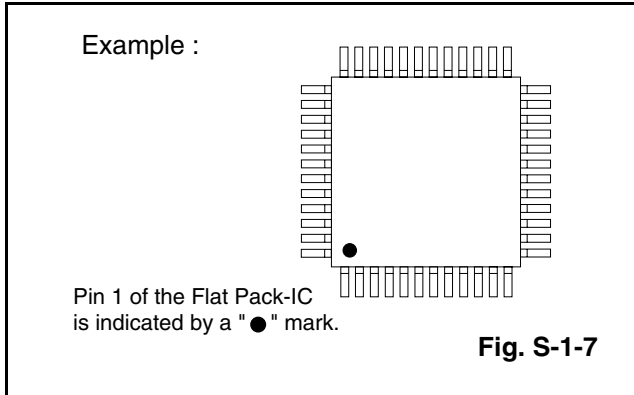

## Instructions for Handling Semi-conductors

Electrostatic breakdown of the semi-conductors may occur due to a potential difference caused by electrostatic charge during unpacking or repair work.

### 1. Ground for Human Body

Be sure to wear a grounding band ( $1M\Omega$ ) that is properly grounded to remove any static electricity that may be charged on the body.

### 2. Ground for Workbench

- (1) Be sure to place a conductive sheet or copper plate with proper grounding ( $1M\Omega$ ) on the workbench or other surface, where the semi-conductors are to be placed. Because the static electricity charge on clothing will not escape through the body grounding band, be careful to avoid contacting semi-conductors with your clothing.

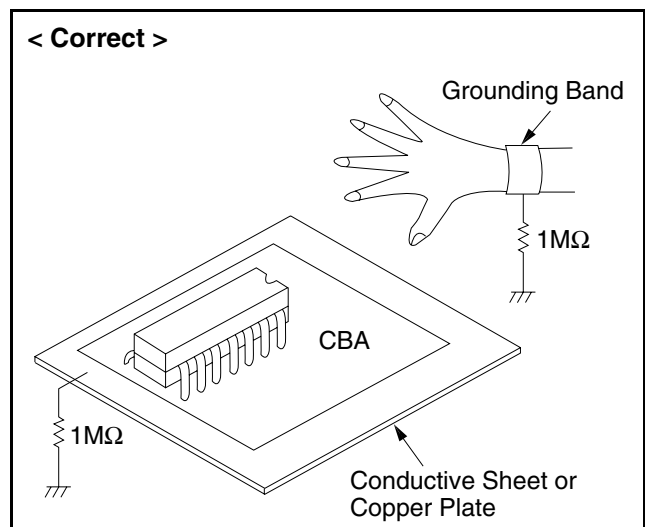
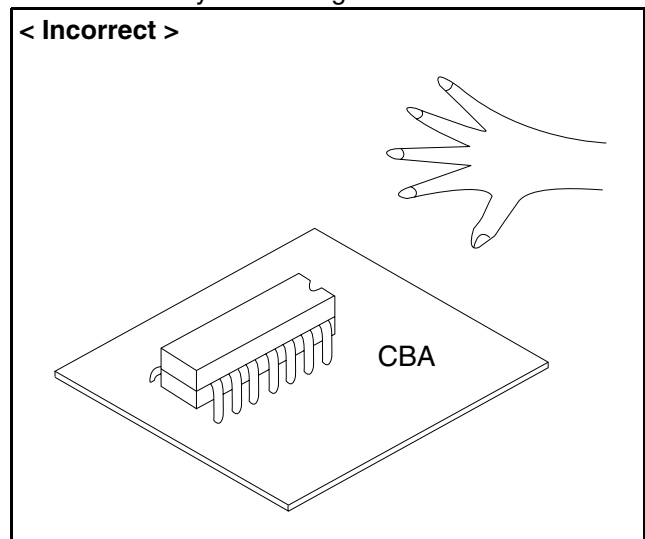

# OPERATING CONTROLS AND FUNCTIONS

## FRONT PANEL

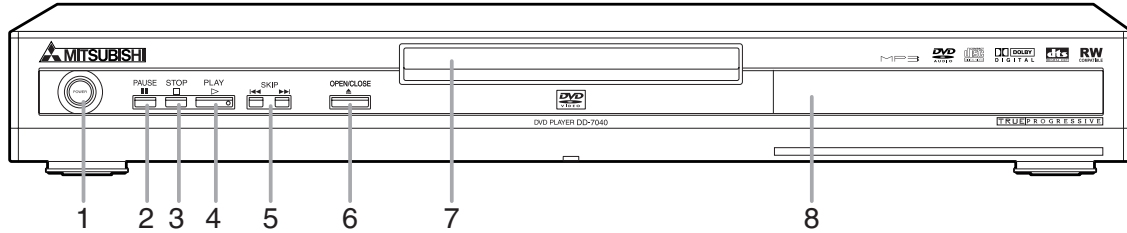

## REMOTE CONTROL

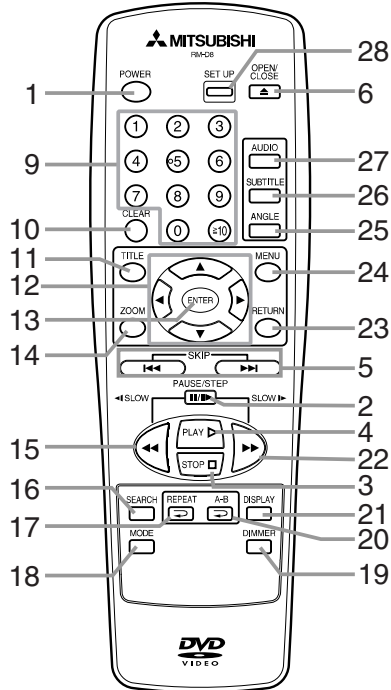

1. **POWER Button**  
Press to turn the power on and off.
2. **PAUSE Button (main unit)**  
Pauses the current disc operation.  
**PAUSE/STEP Button (remote control)**  
Pauses the current disc operation. View the still picture frame by frame.
3. **STOP Button**  
Stops operation of the disc.
4. **PLAY Button**  
Starts playback of the disc contents.
5. **SKIP Buttons**  
▶▶: Plays back from the beginning of the next chapter or track.  
◀◀: Plays back from the beginning of the current chapter or track.
6. **OPEN/CLOSE Button**  
Press to insert or remove discs from the tray.
7. **Disc loading tray**
8. **Display, Remote Sensor Window**
9. **Numeric Buttons**
10. **CLEAR Button**  
Resets a setting.
11. **TITLE Button**  
Displays the title menu.
12. **Arrow Buttons**  
Use to scroll and cycle through disc and player menus and settings.
13. **ENTER Button**  
Press to accept a setting.
14. **ZOOM Button**  
Enlarges part of a DVD-reproduced image.
15. **REV Button**  
Fast reverse playback to a desired point.
16. **SEARCH MODE Button**  
Press to locate a desired point.
17. **REPEAT Button**  
Repeats playback of the current disc, title, chapter or track.
18. **MODE Button**  
Activates program playback or random playback mode when playing DVD-Audio CDs or MP3/JPEG/Picture CD/WMA. Also sets Black level, Image Quality mode, and Noise Reduction. It selects freeze-frame viewing of DVD-Audio.
19. **DIMMER Button**  
Select the display panel brightness.
20. **A-B REPEAT Button**  
Repeats playback of a selected section.
21. **DISPLAY Button**  
Displays timer and bit-rate information on the TV screen.
22. **FWD Button**  
Fast forwards playback to a desired point.
23. **RETURN Button**  
Returns to the previous operation.
24. **MENU Button**  
Displays the disc menus.
25. **ANGLE Button**  
Press to change the camera angle to see the sequence being played back from a different angle.
26. **SUBTITLE Button**  
Press to select a desired subtitle language.
27. **AUDIO Button**  
Press to select a desired audio language or sound mode.
28. **SETUP Button**  
Press to enter the setup mode or to change setup items.

## REAR VIEW

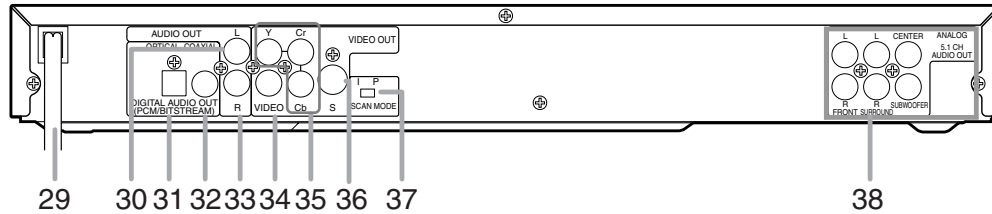

29. Power Cord

30. Left AUDIO OUT Jack

31. OPTICAL DIGITAL AUDIO OUT Jack

32. COAXIAL DIGITAL AUDIO OUT Jack

33. Right AUDIO OUT Jack

34. VIDEO OUT Jack

35. Component Video Out Jacks

36. S-VIDEO OUT Jack

37. SCAN MODE Switch

38. ANALOG 5.1 CH AUDIO OUT Jacks

## DISPLAY

Lights-up when a DVD is inserted

CD:

Lights-up when an audio CD is inserted

VIDEO CD:

Lights-up when a Video CD is inserted

Lights-up when the repeat mode  
or A-B repeat mode is set

Lights-up when  
playback control is activated

Displays a title number

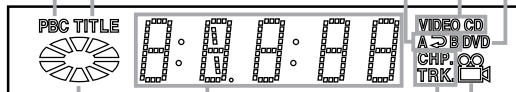

Displays how long a current  
title or track has been played  
back.

When a chapter or track has  
switched, the number of a  
new title, chapter or track is  
displayed.

Displays the disc status

Displays a chapter or track number

Lights-up when the  
multi-angle scene is taken

It is possible to change the brightness of display  
unit by pressing the DIMMER button of remote  
control.

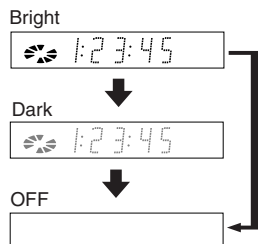

- When the power supply is turned off, the display is returned to the setup status.

## DISPLAYS DURING OPERATION

	("ON" is lit.)	Power on
	("Disc icon" blinks.)	Tray open and closed
	("Disc icon" rotates.)	LOAD
	("Disc icon" rotates.)	During playback
	(A segment on "Disc icon" blinks.)	During pause
	(Two segments on "Disc icon" blink.)	Stop (Resume ON)
	("Disc icon" is lit.)	Stop (Resume OFF)
	("OFF" is lit.)	Power off
		No disc or error
	("-----" is lit.)	ERROR

# CABINET DISASSEMBLY INSTRUCTIONS

## 1. Disassembly Flowchart

This flowchart indicates the disassembly steps to gain access to item(s) to be serviced. When reassembling, follow the steps in reverse order. Bend, route, and dress the cables as they were originally.

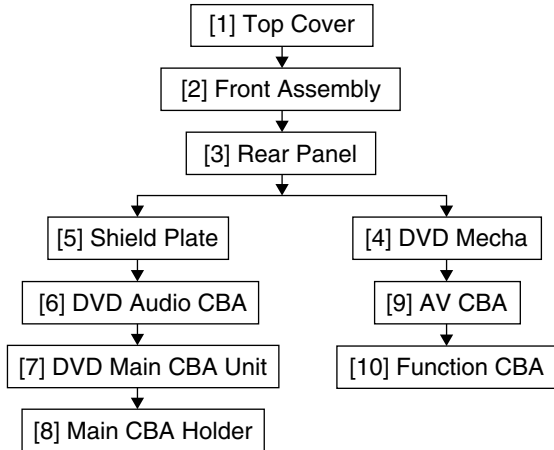

## 2. Disassembly Method

ID/ LOC. No.	PART	REMOVAL		
		Fig. No.	REMOVE/*UNHOOK/ UNLOCK/RELEASE/ UNPLUG/DESOLDER	Note
[1]	Top Cover	D1	5(S-1)	-
[2]	Front Assembly	D2	*2(L-1), Tray Panel, *2(L-2), *5(L-3), *3(L-4)	1-1 1-2 1-3 1-4 1-5 1-6 1-7
[3]	Rear Panel	D3	5(S-2), 2(S-3), (S-4)	-
[4]	DVD Mecha	D4, D5	*CN301, 3(S-5), *CN201	2 2-1 2-2 2-3 3
[5]	Shield Plate	D4	(S-6), 2(S-7)	-
[6]	DVD Audio CBA	D4	*CN1602, *CN7102, *3(L-5)	-
[7]	DVD Main CBA Unit	D4	2(S-8), *CN1001, *CN1601	-
[8]	Main CBA Holder	D4	(S-9)	-
[9]	AV CBA	D6	3(S-10)	-
[10]	Function CBA	D6	Desolder	-

(1) (2) (3) (4) (5)

- (1): Identification (location) No. of parts in the figures  
 (2): Name of the part  
 (3): Figure Number for reference  
 (4): Identification of parts to be removed, unhooked, unlocked, released, unplugged, unclamped, or desoldered.  
 P=Spring, L=Locking Tab, S=Screw, CN=Connector  
 \*=Unhook, Unlock, Release, Unplug, or Desolder  
 e.g. 2(S-2) = two Screws (S-2),  
 2(L-2) = two Locking Tabs (L-2)  
 (5): Refer to "Reference Notes."

### Reference Notes

CAUTION 1: Locking Tabs (L-1), (L-2), (L-3) and (L-4) are fragile. Be careful not to break them.

- 1-1. Connect the wall plug to an AC outlet and press the OPEN/CLOSE button to open the Tray.
- 1-2. Remove the Tray Panel by releasing two Locking Tabs (L-1).
- 1-3. Press the OPEN/CLOSE button again to close the Tray.
- 1-4. Press the POWER button to turn the power off.
- 1-5. Unplug an AC cord.
- 1-6. Release two Locking Tabs (L-2). Then, release five Locking Tabs (L-3) (to do this, first release two Locking Tabs (A) at the side, and then three Locking Tabs (B) at the bottom.)
- 1-7. Release three Locking Tabs (L-4). Then remove the Front Assembly.

CAUTION 2: Electrostatic breakdown of the laser diode in the optical system block may occur as a potential difference caused by electrostatic charge accumulated on cloth, human body etc., during unpacking or repair work.

To avoid damage of pickup follow next procedures.

- 2-1. Disconnect Connector (CN301). Remove three Screws (S-5) and lift the DVD Mecha. (Fig. D4)
- 2-2. Slide out the pickup unit as shown in Fig. D5.
- 2-3. Short the three short lands with solder before removing the FFC cable (CN201) from it. If you disconnect the FFC cable (CN201), the laser diode of pickup will be destroyed. (Fig. D5)

CAUTION 3: When reassembling, confirm the FFC cable (CN201) is connected completely. Then remove the solder from the three short lands of FFC cable. (Fig. D5)

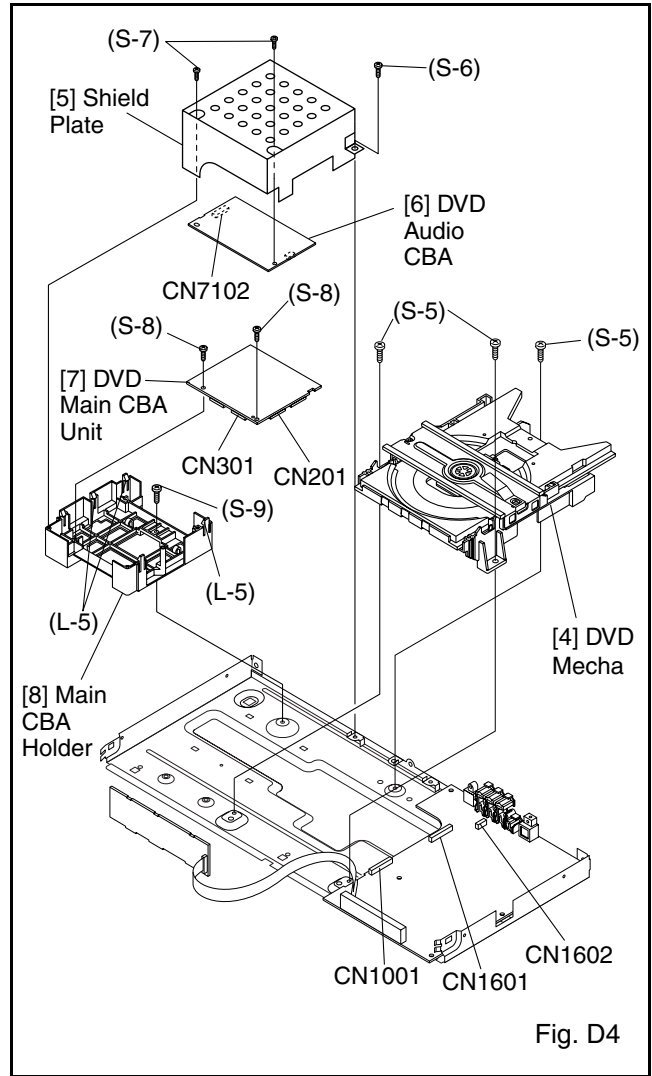
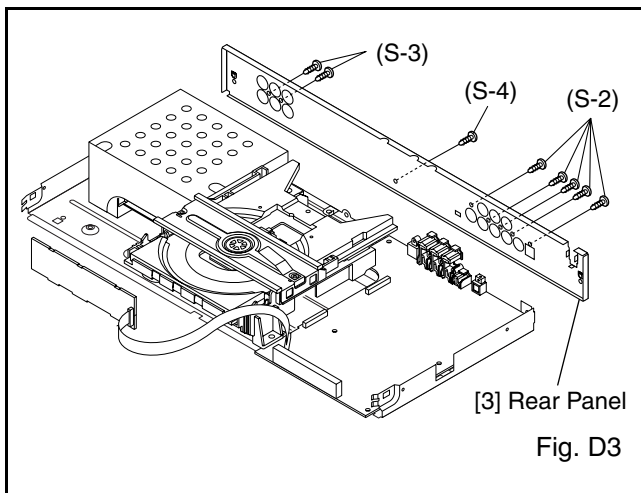
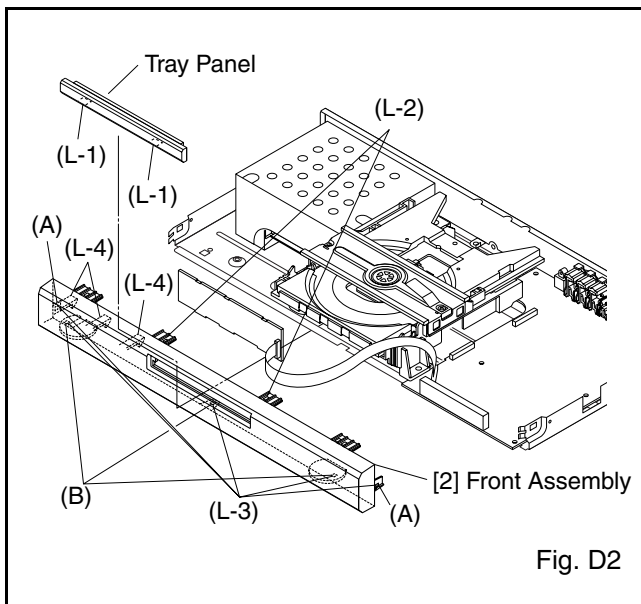
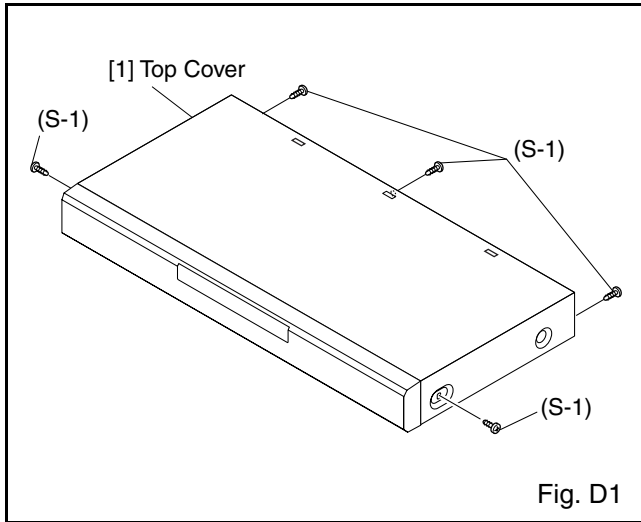

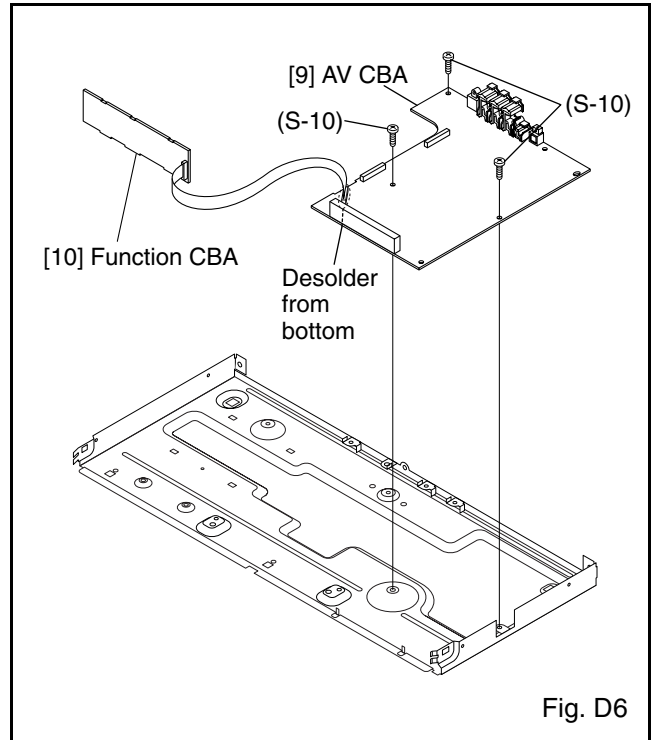
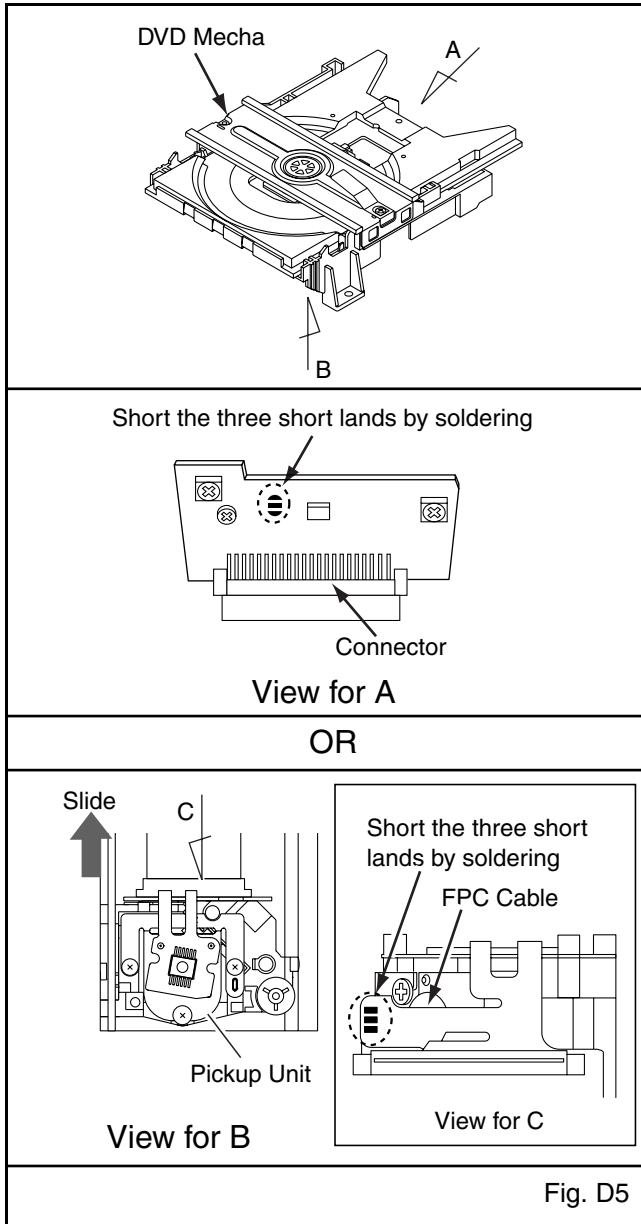

## HOW TO MANUAL EJECT

1. Remove the Top Case.
2. Rotate the roulette in the direction of the arrow as shown below.

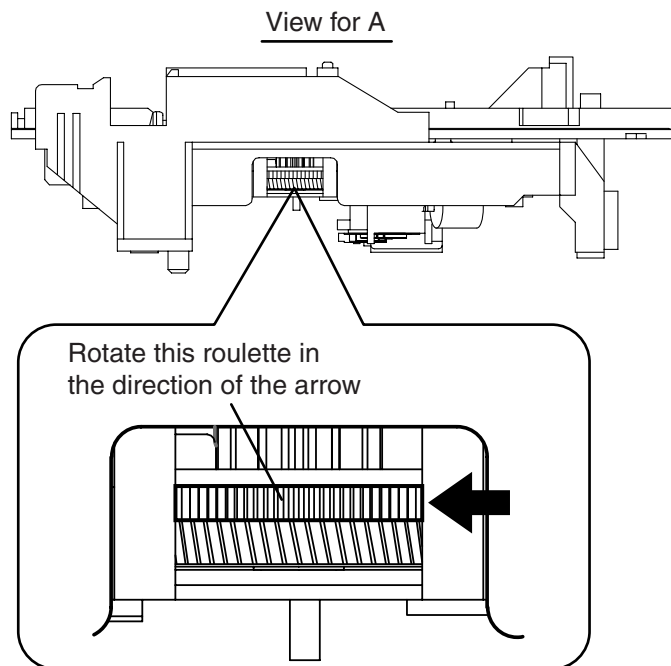
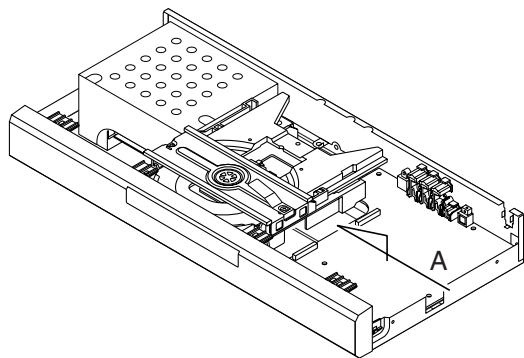

# BLOCK DIAGRAMS

## System Control/Servo Block Diagram

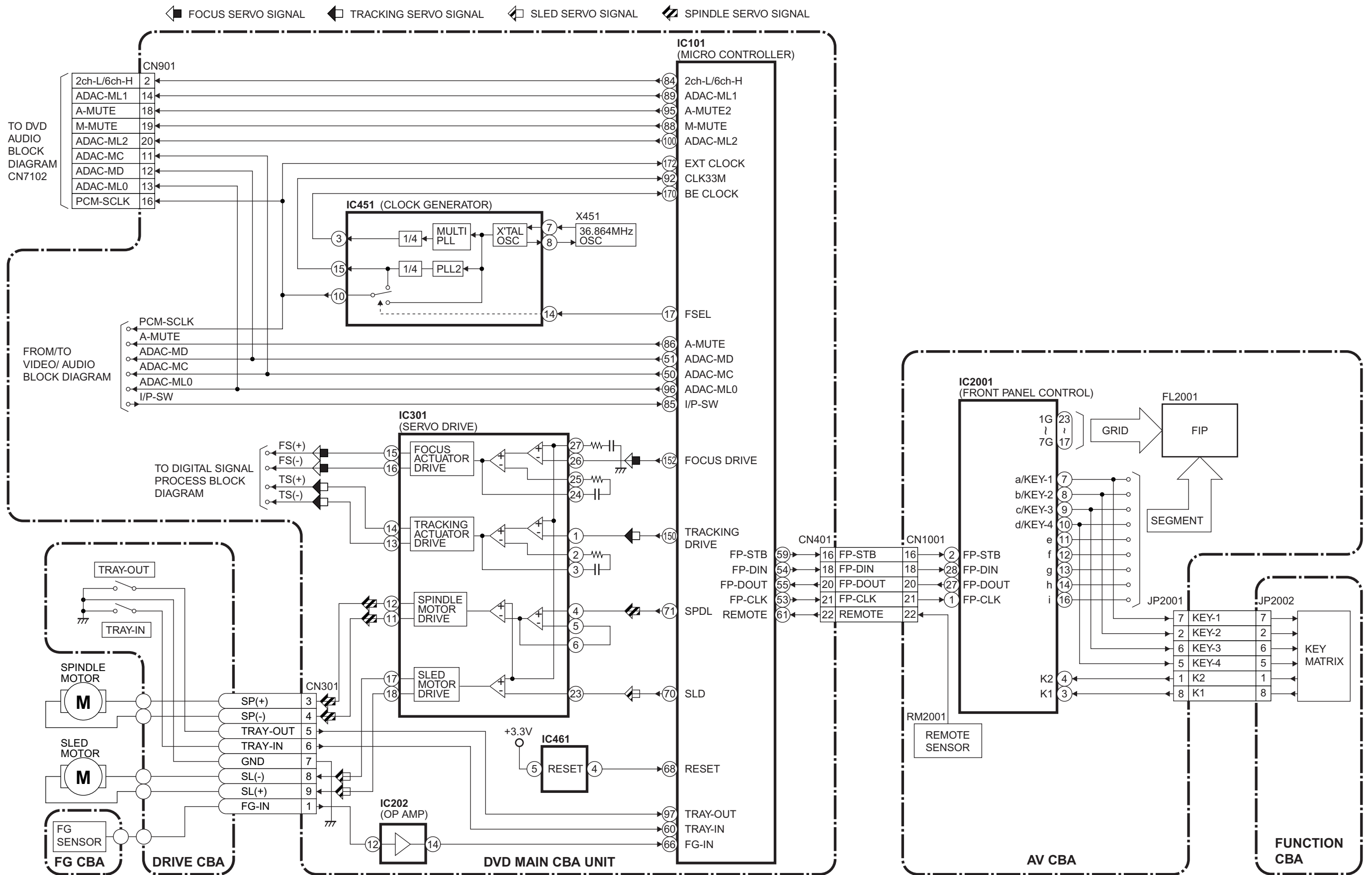



# Digital Signal Process Block Diagram

DATA(VIDEO/AUDIO) SIGNAL  
  VIDEO SIGNAL  
  DATA(AUDIO) SIGNAL  
  FOCUS SERVO SIGNAL  
  TRACKING SERVO SIGNAL

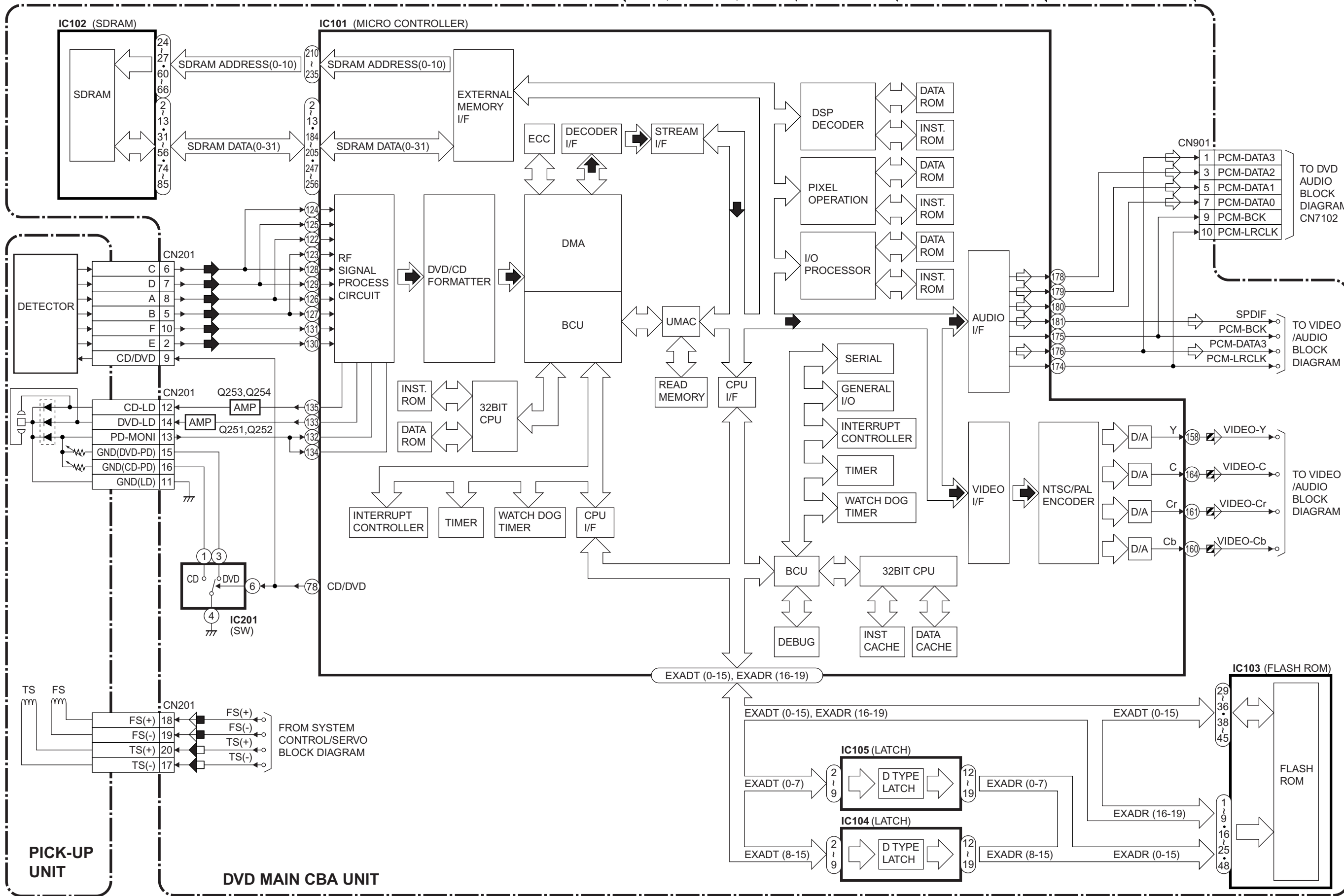

# Video / Audio Block Diagram

VIDEO SIGNAL  
 DATA(AUDIO) SIGNAL  
 AUDIO SIGNAL

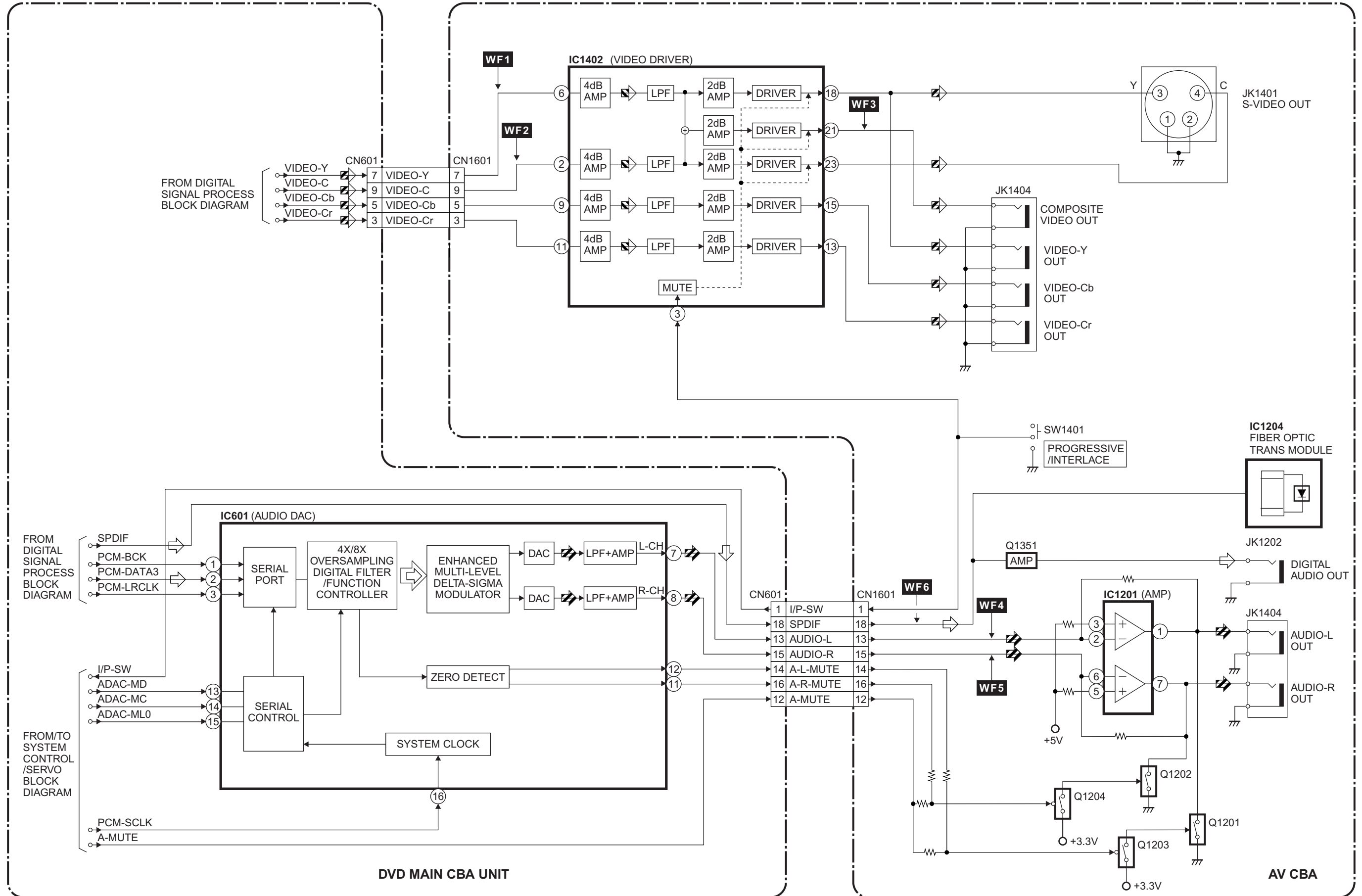

# DVD Audio Block Diagram

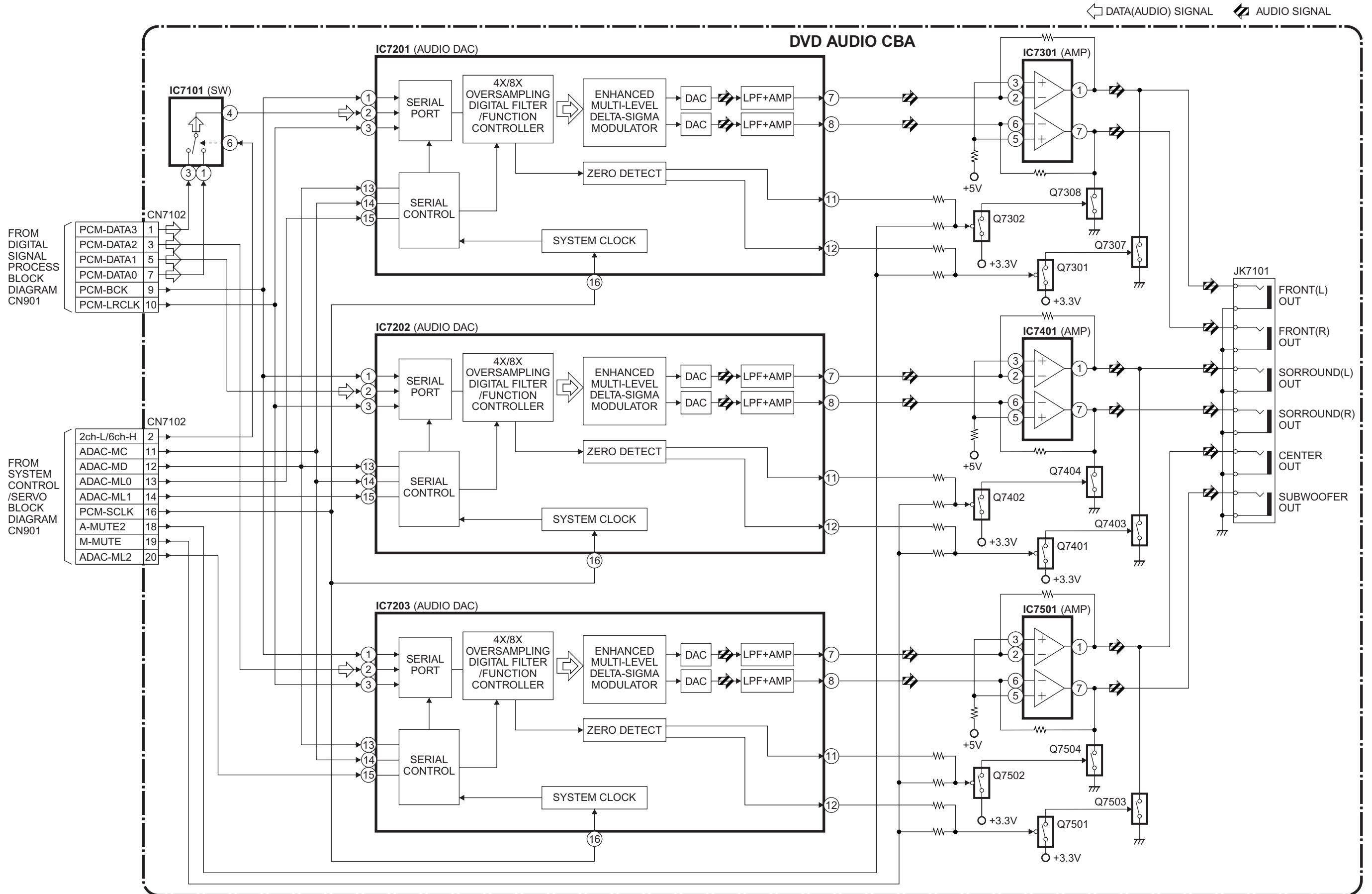

# Power Supply Block Diagram

## CAUTION !

Fixed voltage ( or Auto voltage selectable ) power supply circuit is used in this unit.  
 If Main Fuse (F1001) is blown, check to see that all components in the power supply circuit are not defective before you connect the AC plug to the AC power supply.  
 Otherwise it may cause some components in the power supply circuit to fail.

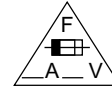

## CAUTION

FOR CONTINUED PROTECTION AGAINST FIRE HAZARD,  
 REPLACE ONLY WITH THE SAME TYPE FUSE.  
 ATTENTION : POUR UNE PROTECTION CONTINUE LES RISQUES  
 D'INCELE N'UTILISER QUE DES FUSIBLE DE MÊME TYPE.

**RISK OF FIRE** -REPLACE FUSE AS MARKED.

"This symbol means fast operating fuse."  
 "Ce symbole représente un fusible à fusion rapide."

## NOTE :

The voltage for parts in hot circuit is measured using hot GND as a common terminal.

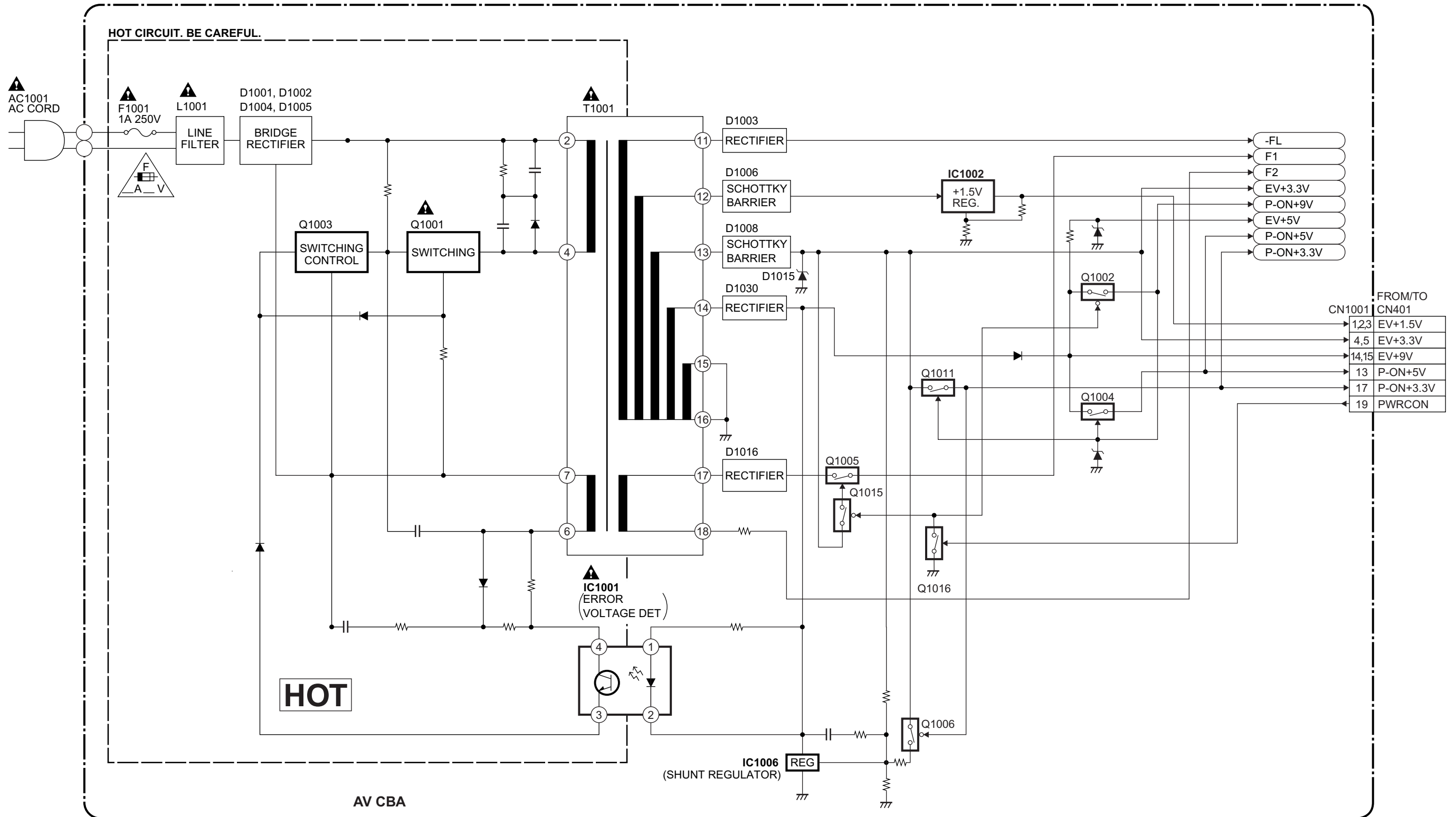

# SCHEMATIC DIAGRAMS / CBA'S AND TEST POINTS

## Standard Notes

### WARNING

Many electrical and mechanical parts in this chassis have special characteristics. These characteristics often pass unnoticed and the protection afforded by them cannot necessarily be obtained by using replacement components rated for higher voltage, wattage, etc. Replacement parts that have these special safety characteristics are identified in this manual and its supplements; electrical components having such features are identified by the mark "▲" in the schematic diagram and the parts list. Before replacing any of these components, read the parts list in this manual carefully. The use of substitute replacement parts that do not have the same safety characteristics as specified in the parts list may create shock, fire, or other hazards.

### Notes:

1. Do not use the part number shown on these drawings for ordering. The correct part number is shown in the parts list, and may be slightly different or amended since these drawings were prepared.
2. All resistance values are indicated in ohms ( $K=10^3$ ,  $M=10^6$ ).
3. Resistor wattages are 1/4W or 1/6W unless otherwise specified.
4. All capacitance values are indicated in  $\mu F$  ( $P=10^{-6} \mu F$ ).
5. All voltages are DC voltages unless otherwise specified.

**LIST OF CAUTION, NOTES, AND SYMBOLS USED IN THE SCHEMATIC DIAGRAMS ON THE FOLLOWING PAGES:**

**1. CAUTION:**

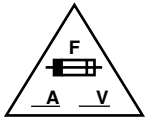

FOR CONTINUED PROTECTION AGAINST FIRE HAZARD, REPLACE ONLY WITH THE SAME TYPE FUSE.  
 ATTENTION: POUR UNE PROTECTION CONTINUE LES RISQUES D'INCELE N'UTILISER QUE DES FUSIBLE DE MÊME TYPE.  
 RISK OF FIRE-REPLACE FUSE AS MARKED.



This symbol means fast operating fuse.  
 Ce symbole représente un fusible à fusion rapide.

**2. CAUTION:**

Fixed Voltage (or Auto voltage selectable) power supply circuit is used in this unit.  
 If Main Fuse (F1001) is blown, first check to see that all components in the power supply circuit are not defective before you connect the AC plug to the AC power supply. Otherwise it may cause some components in the power supply circuit to fail.

**3. Note:**

- (1) Do not use the part number shown on the drawings for ordering. The correct part number is shown in the parts list, and may be slightly different or amended since the drawings were prepared.
- (2) To maintain original function and reliability of repaired units, use only original replacement parts which are listed with their part numbers in the parts list section of the service manual.

**4. Wire Connectors**

- (1) Prefix symbol "CN" means "connector" (can disconnect and reconnect).
- (2) Prefix symbol "CL" means "wire-solder holes of the PCB" (wire is soldered directly).

**5. Voltage indications for PLAY and STOP mode on the schematics are as shown below:**

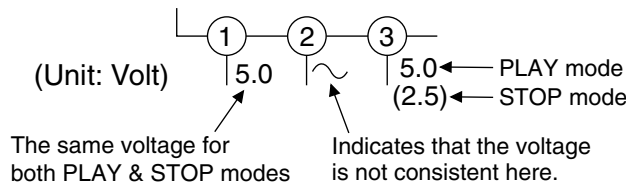

**6. How to read converged lines**

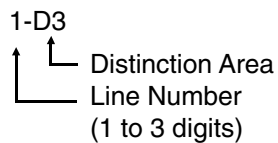

Examples:

1. "1-D3" means that line number "1" goes to area "D3".
2. "1-B1" means that line number "1" goes to area "B1".

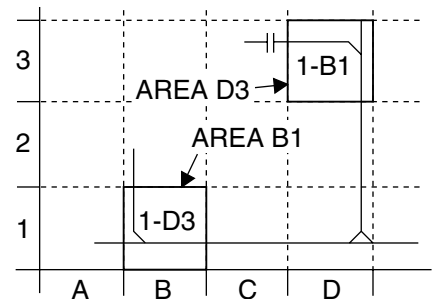

**7. Test Point Information**

- ⊙ : Indicates a test point with a jumper wire across a hole in the PCB.
- : Used to indicate a test point with a component lead on foil side.
- ⊘ : Used to indicate a test point with no test pin.
- : Used to indicate a test point with a test pin.

# DVD Main 1/3 Schematic Diagram

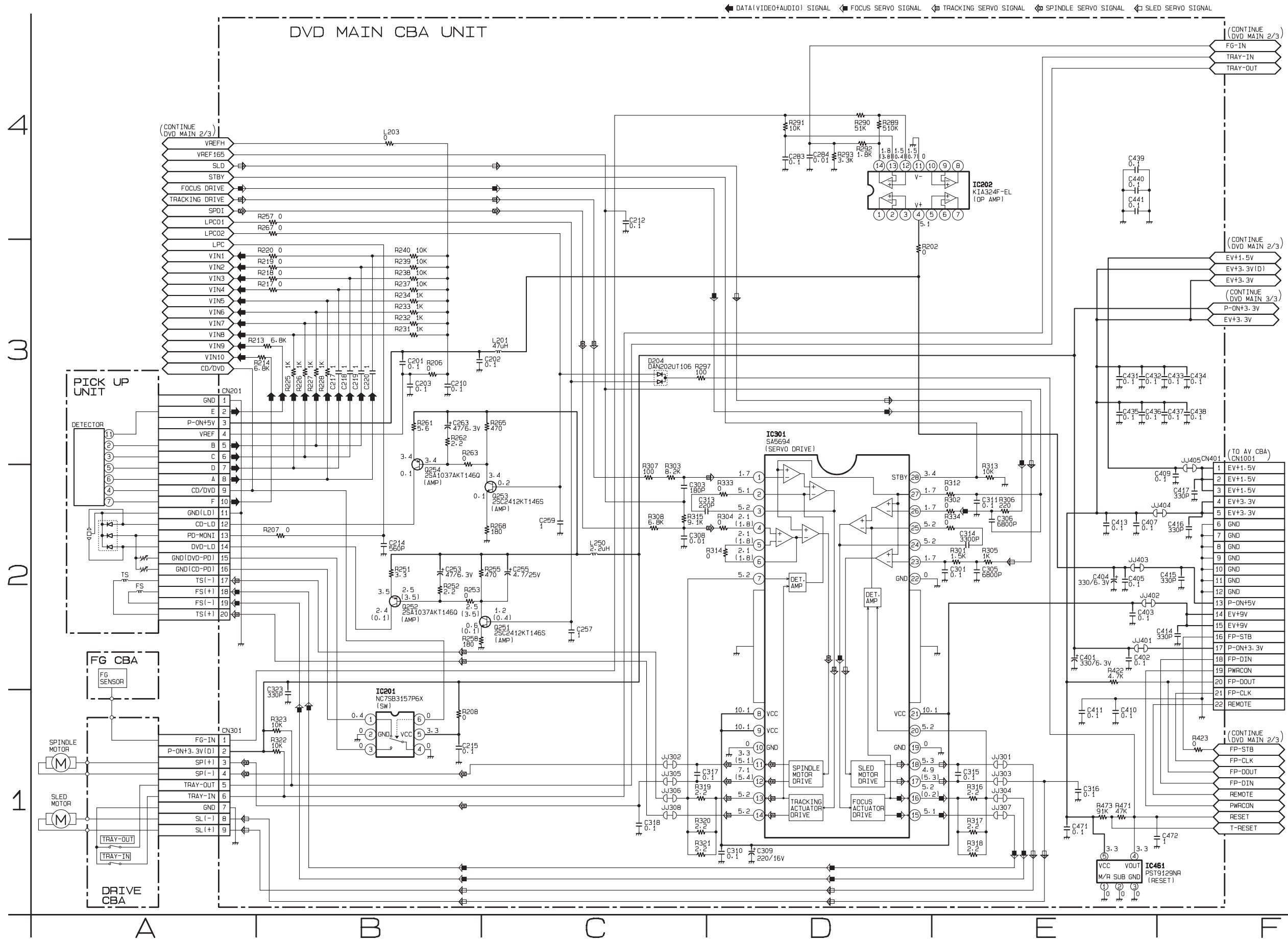

# DVD Main 2/3 Schematic Diagram

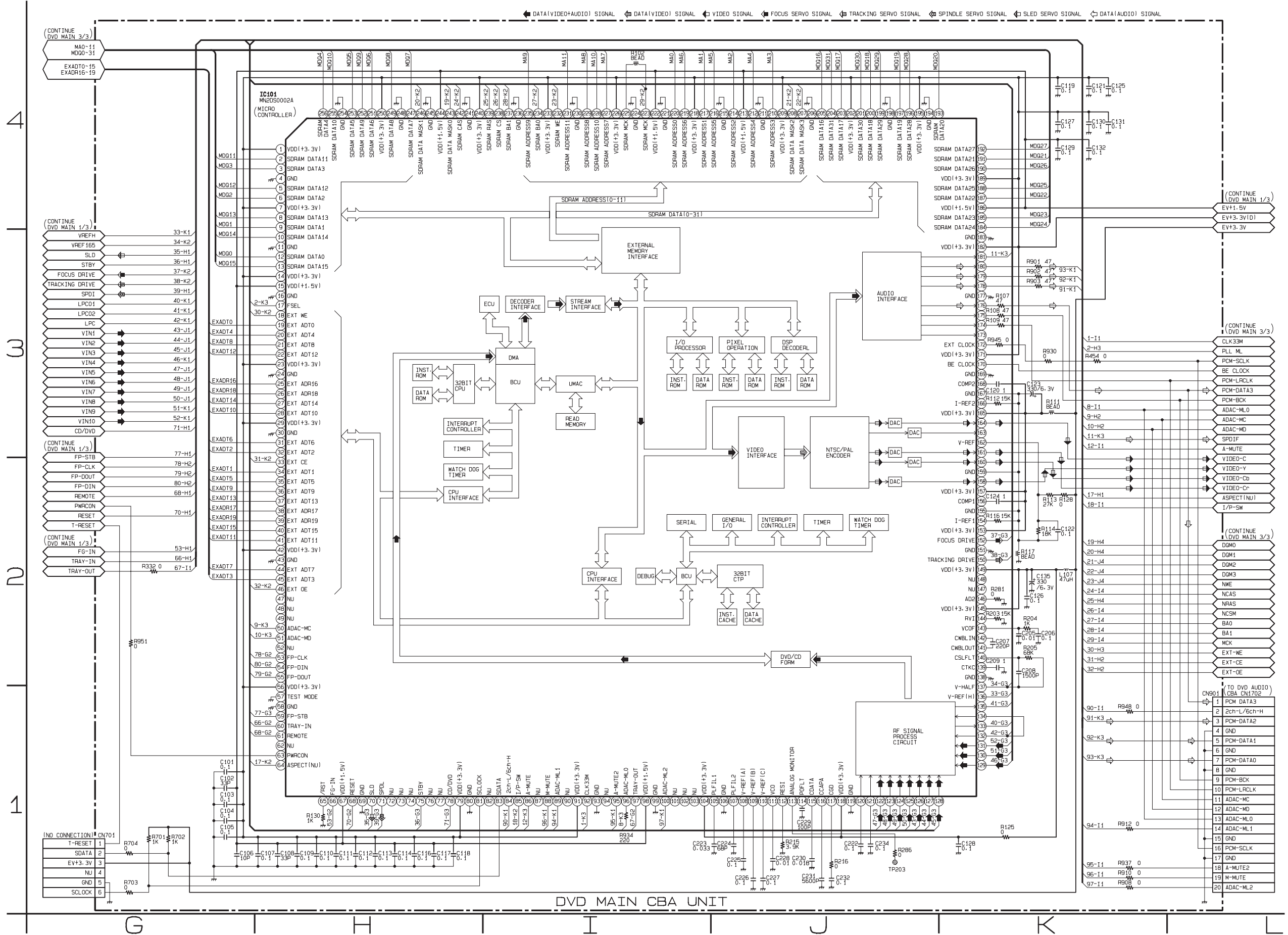



## IC101 VOLTAGE CHART

PIN.NO	PLAY	STOP	PIN.NO	PLAY	STOP	PIN.NO	PLAY	STOP	PIN.NO	PLAY	STOP	PIN.NO	PLAY	STOP	PIN.NO	PLAY	STOP	PIN.NO	PLAY	STOP	PIN.NO	PLAY	STOP
1	3.3	3.3	33	2.2	2.9	65	0.1	0.1	97	3.4	3.4	129	2.0	2.0	161	0.5	0.5	193	~	~	225	1.9	1.9
2	~	~	34	~	~	66	1.2	2.5	98	1.6	1.6	130	2.2	2.2	162	1.4	1.4	194	0	0	226	3.3	3.3
3	~	~	35	~	~	67	1.6	1.6	99	0	0	131	2.3	2.3	163	----	----	195	3.3	3.3	227	~	~
4	0	0	36	~	~	68	3.4	3.4	100	3.4	3.4	132	0.4	0.1	164	0.9	0.9	196	~	~	228	~	~
5	~	~	37	~	~	69	0	0	101	----	----	133	1.2	0.4	165	3.3	3.3	197	~	~	229	~	~
6	~	~	38	0.3	0.5	70	1.7	1.7	102	----	----	134	0.4	0.1	166	1.5	1.5	198	0	0	230	0	0
7	3.3	3.3	39	0.1	0.1	71	2.4	1.7	103	----	----	135	0.2	0.2	167	0	0	199	~	~	231	~	~
8	~	~	40	~	~	72	----	----	104	3.3	3.3	136	2.3	2.3	168	2.1	2.1	200	~	~	232	3.3	3.3
9	~	~	41	~	~	73	----	----	105	0.9	0.9	137	1.7	1.7	169	0	0	201	~	~	233	3.3	3.3
10	~	~	42	3.3	3.3	74	----	----	106	0	0	138	0	0	170	0.8	0.8	202	3.3	3.3	234	1.6	1.6
11	0	0	43	0	0	75	3.4	3.4	107	0.8	0.8	139	1.7	1.7	171	3.3	3.3	203	~	~	235	~	~
12	~	~	44	~	~	76	----	----	108	1.6	1.6	140	1.7	1.7	172	1.6	1.6	204	~	~	236	0	0
13	~	~	45	~	~	77	----	----	109	2.1	2.1	141	1.7	1.7	173	----	----	205	~	~	237	1.7	1.7
14	3.3	3.3	46	2.0	2.6	78	0.1	0.1	110	2.6	2.6	142	1.7	1.7	174	1.8	1.8	206	0	0	238	3.0	3.0
15	1.5	1.5	47	----	----	79	3.3	3.3	111	2.0	2.0	143	0.5	0.5	175	1.7	1.7	207	2.4	3.5	239	3.3	3.3
16	0	0	48	----	----	80	0	0	112	0.7	0.9	144	1.6	1.6	176	1.4	0.1	208	2.4	2.1	240	3.3	3.3
17	3.4	3.4	49	----	----	81	3.3	3.3	113	2.0	2.0	145	3.3	3.3	177	0	0	209	3.3	3.3	241	0	0
18	3.4	3.4	50	3.4	3.4	82	----	----	114	1.8	1.8	146	0	0	178	----	----	210	~	~	242	3.2	3.2
19	~	~	51	3.4	3.4	83	3.4	3.4	115	1.4	1.4	147	----	----	179	----	----	211	0	0	243	2.4	2.1
20	~	~	52	----	----	84	2.4	2.4	116	0.3	0.3	148	----	----	180	----	----	212	~	~	244	1.5	1.5
21	~	~	53	3.4	3.4	85	3.0	3.0	117	1.6	1.6	149	3.3	3.3	181	1.7	1.7	213	1.5	1.5	245	0	0
22	~	~	54	3.4	3.4	86	3.4	0.1	118	3.3	3.3	150	1.7	1.7	182	3.3	3.3	214	~	~	246	2.4	2.1
23	3.3	3.3	55	3.3	3.3	87	----	----	119	0	0	151	0	0	183	0	0	215	0	0	247	~	~
24	0	0	56	3.3	3.3	88	0.1	0.1	120	1.9	1.9	152	1.7	1.7	184	~	~	216	~	~	248	0	0
25	0.4	0.4	57	0	0	89	3.4	3.4	121	1.9	1.9	153	3.3	3.3	185	~	~	217	~	~	249	~	~
26	0.9	0.6	58	0	0	90	----	----	122	2.4	2.4	154	1.4	1.4	186	1.5	1.5	218	3.3	3.3	250	3.3	3.3
27	~	~	59	3.3	3.3	91	3.3	3.3	123	2.4	2.4	155	0	0	187	~	~	219	~	~	251	~	~
28	~	~	60	3.4	3.4	92	1.7	1.5	124	2.4	2.4	156	2.2	2.2	188	~	~	220	~	~	252	~	~
29	3.3	3.3	61	3.1	3.1	93	0	0	125	2.4	2.4	157	3.3	3.3	189	3.3	3.3	221	0	0	253	~	~
30	0	0	62	----	----	94	----	----	126	2.0	2.0	158	0.7	0.7	190	~	~	222	1.5	1.5	254	0	0
31	~	~	63	3.4	3.4	95	3.4	0.1	127	2.0	2.0	159	0	0	191	~	~	223	1.9	1.9	255	~	~
32	~	~	64	0.8	0.8	96	3.4	3.4	128	2.0	2.0	160	0.5	0.5	192	~	~	224	0	0	256	~	~

# DVD Main 3/3 Schematic Diagram

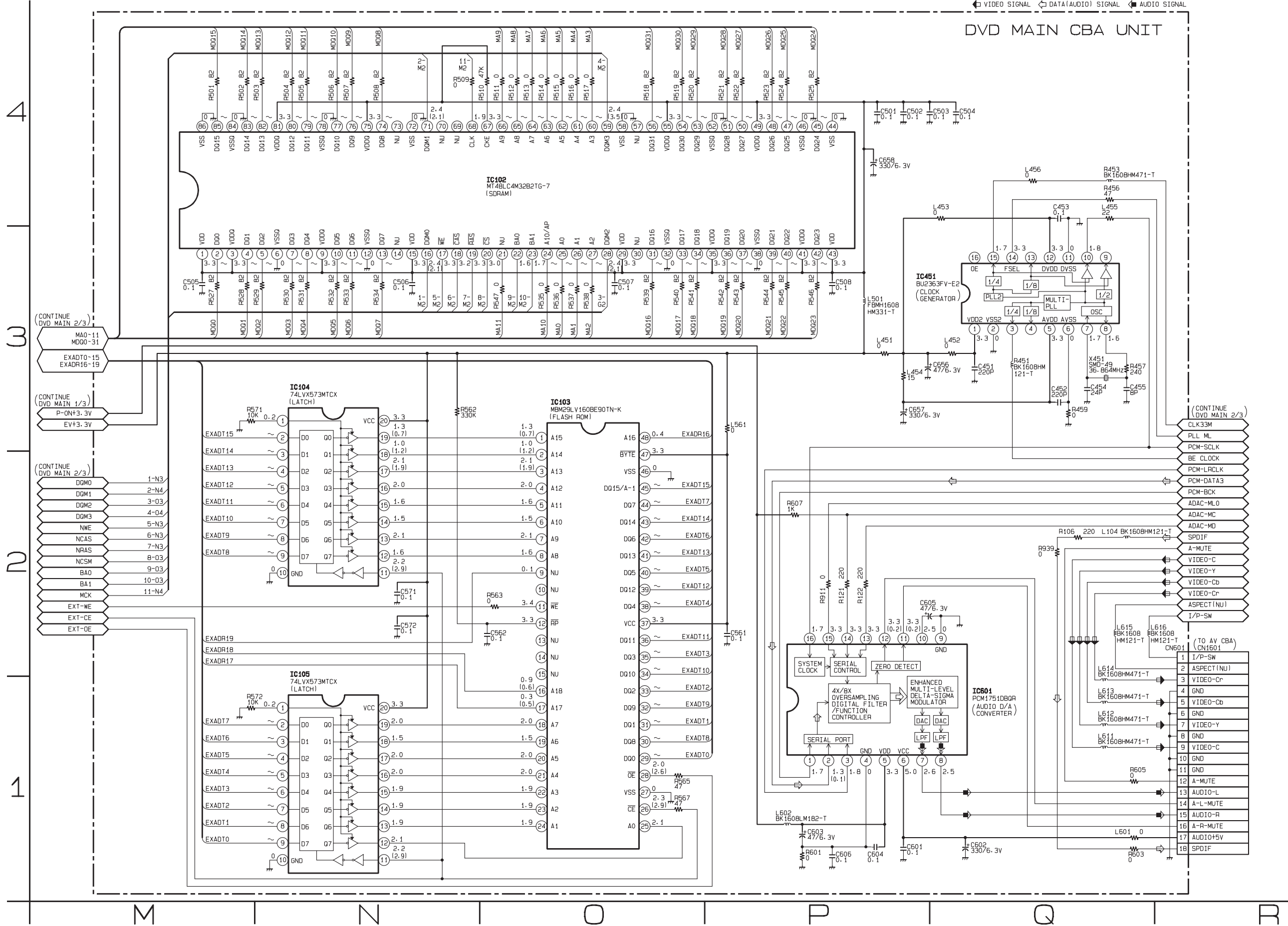

# AV 1/3 Schematic Diagram

## CAUTION !

Fixed voltage ( or Auto voltage selectable ) power supply circuit is used in this unit.  
If Main Fuse (F1001) is blown, check to see that all components in the power supply circuit are not defective before you connect the AC plug to the AC power supply.  
Otherwise it may cause some components in the power supply circuit to fail.

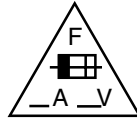

## CAUTION

FOR CONTINUED PROTECTION AGAINST FIRE HAZARD,  
REPLACE ONLY WITH THE SAME TYPE FUSE.  
ATTENTION : POUR UNE PROTECTION CONTINUE LES RISQUES  
D'INCELE N'UTILISER QUE DES FUSIBLE DE MÊME TYPE.

## RISK OF FIRE-REPLACE FUSE AS MARKED.



"This symbol means fast operating fuse."

"Ce symbole représente un fusible à fusion rapide."

## NOTE :

The voltage for parts in hot circuit is measured using hot GND as a common terminal.

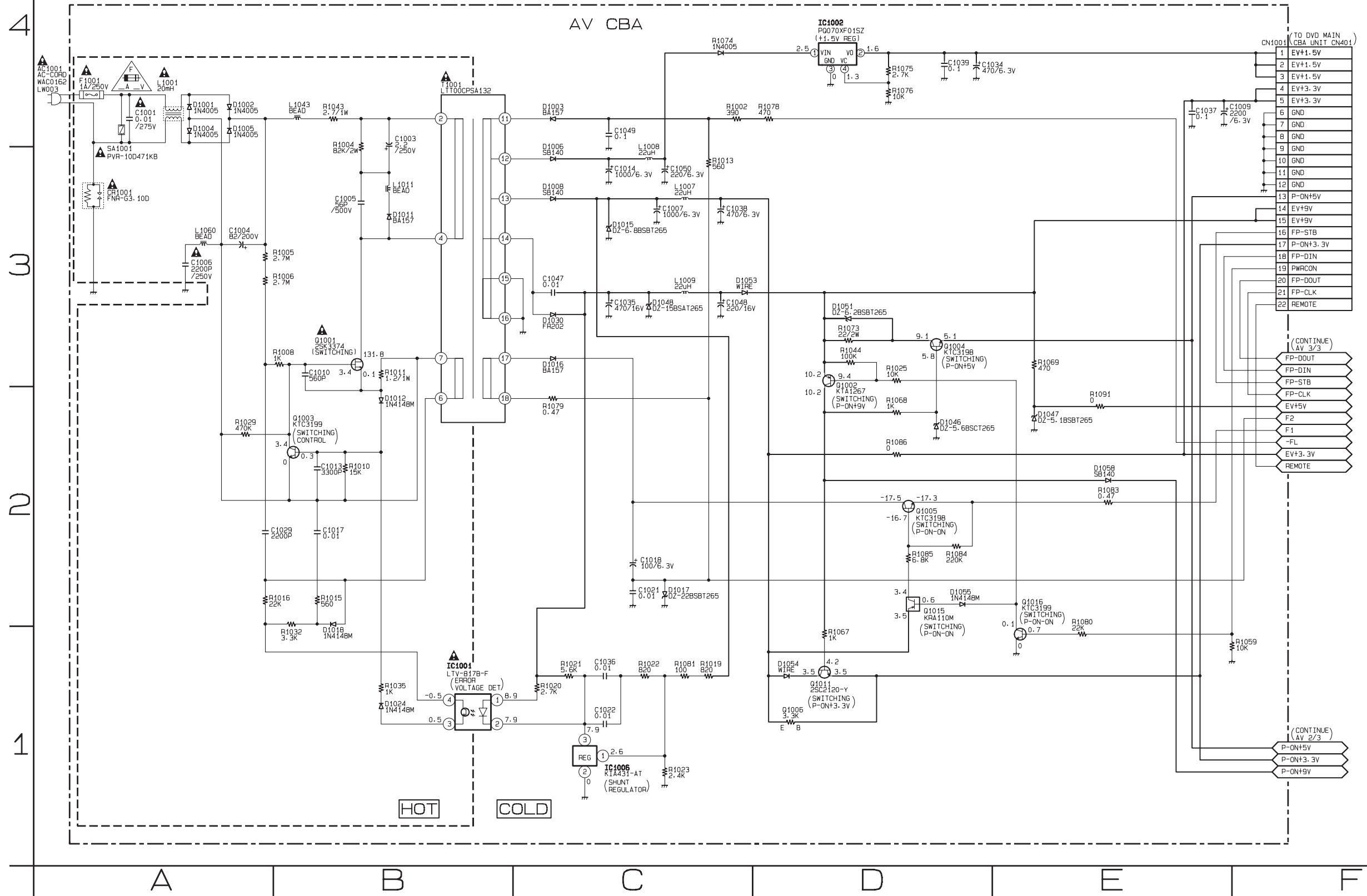

# AV 2/3 Schematic Diagram

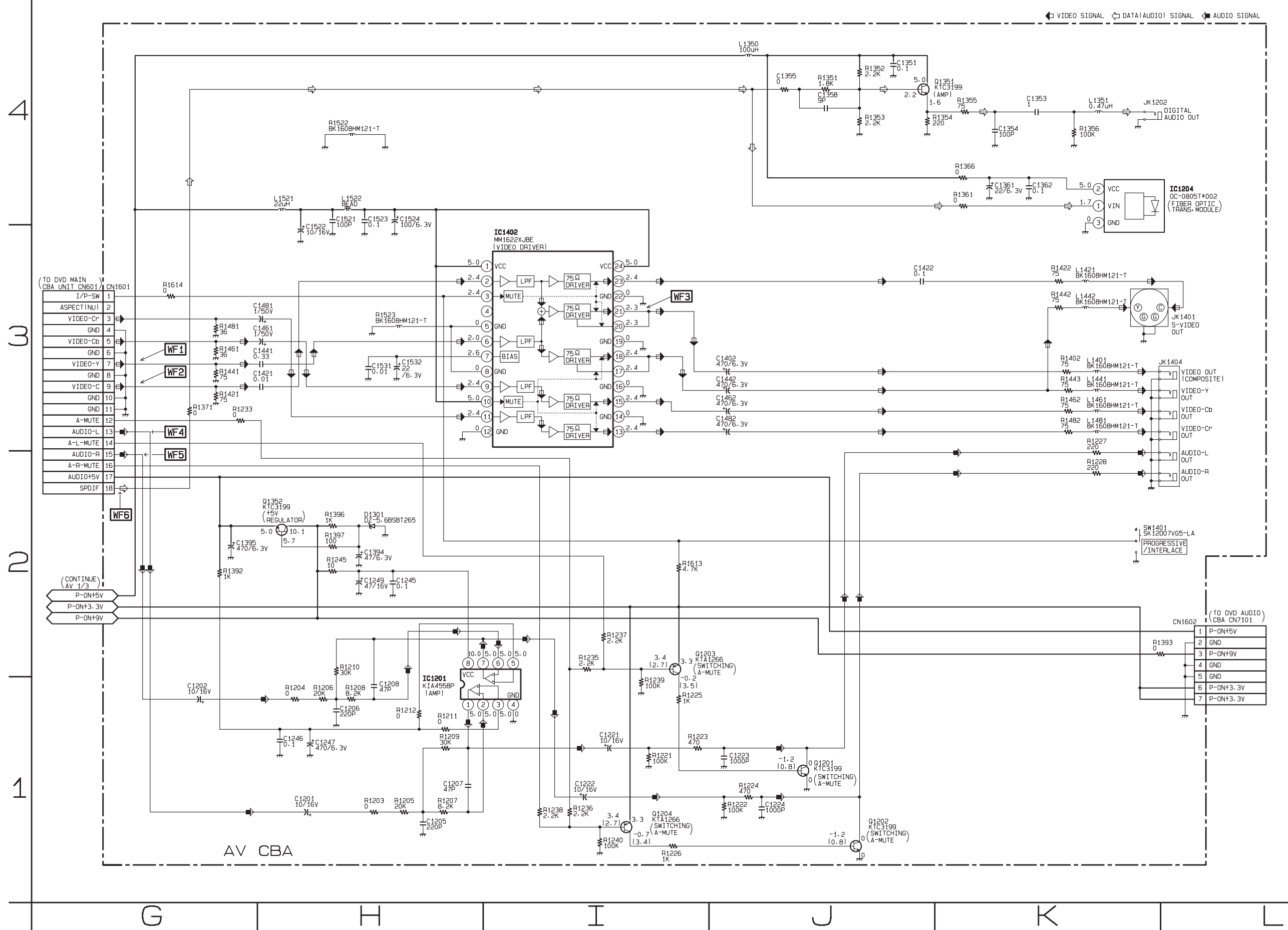

# AV 3/3 & Function Schematic Diagram

4

3

2

1

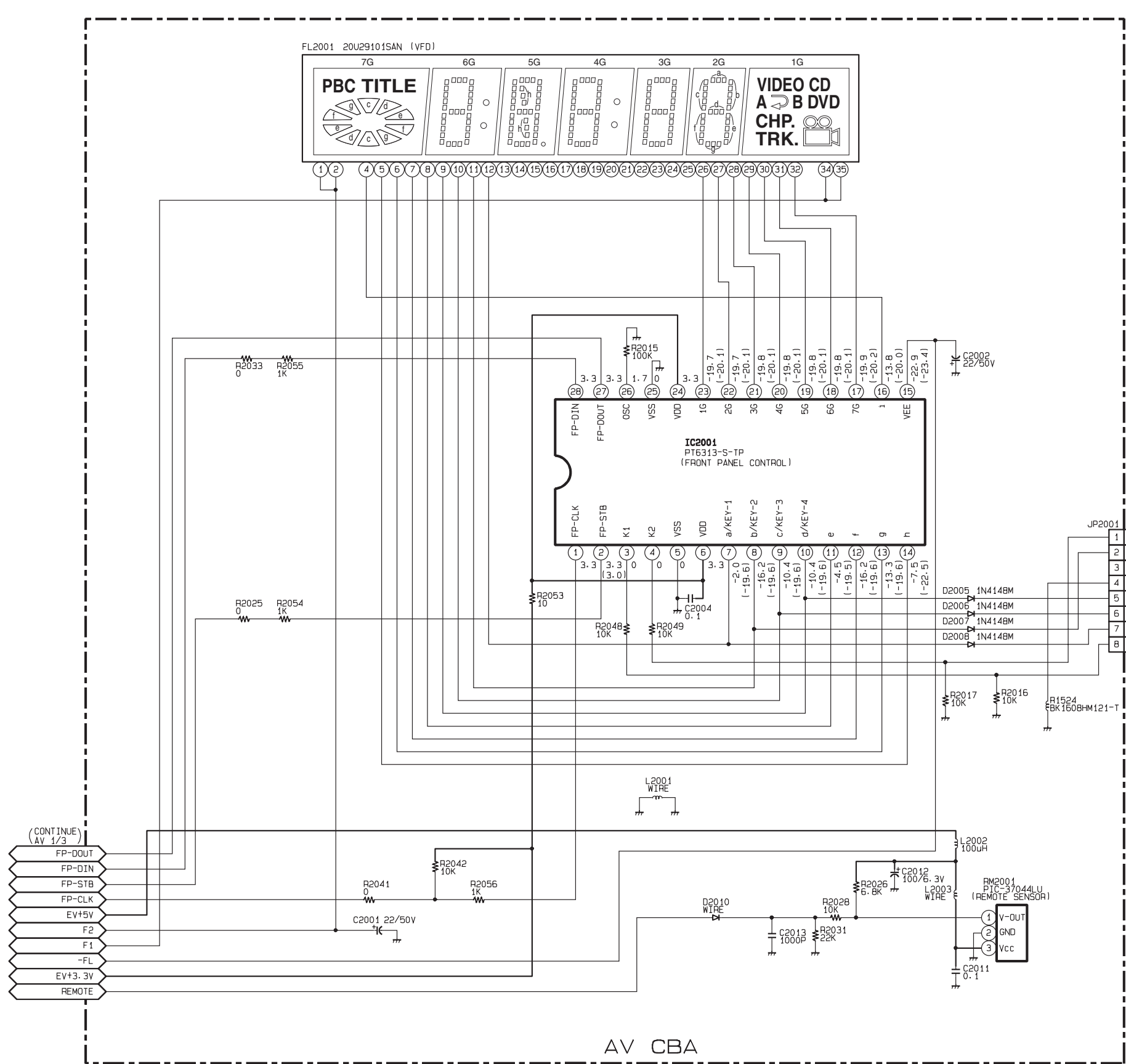

FL2001 MATRIX CHART

	7G	6G	5G	4G	3G	2G	1G
a	PBC	a	a	a	a	a	VIDEO
b	TITLE	b	b	b	b	b	CD
c	c	c	c	c	c	c	A
d	d	d	d	d	d	d	↶
e	e	e	e	e	e	e	B
f	f	f	f	f	f	f	DVD
g	g	g	g	g	g	g	CHP.
h	○	○	○	○	○	○	TRK.
i	○	○	○	○	○	○	📺

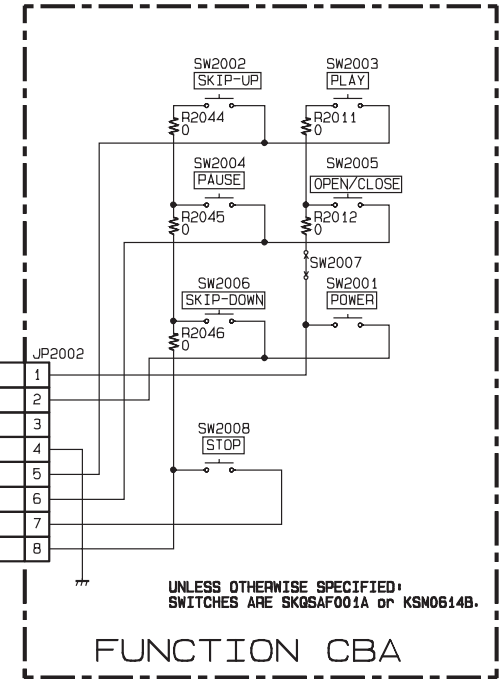

UNLESS OTHERWISE SPECIFIED:  
SWITCHES ARE SKQSAF001A or KSN0614B.

FUNCTION CBA

M I N I O I P I Q

# DVD Audio Schematic Diagram

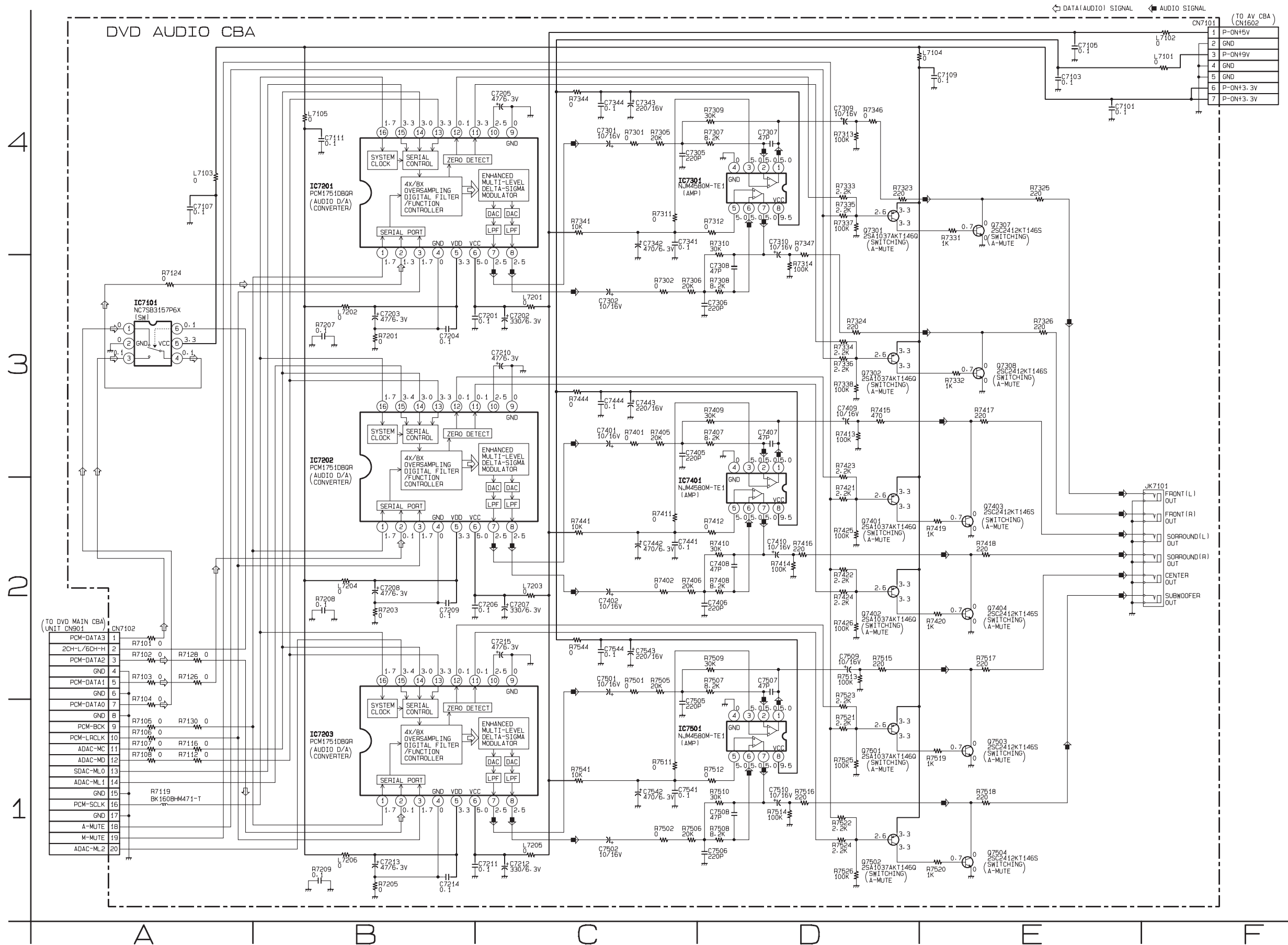

# AV CBA Top View

## CAUTION !

Fixed voltage ( or Auto voltage selectable ) power supply circuit is used in this unit.  
If Main Fuse (F1001) is blown, check to see that all components in the power supply circuit are not defective before you connect the AC plug to the AC power supply.  
Otherwise it may cause some components in the power supply circuit to fail.

## NOTE :

The voltage for parts in hot circuit is measured using hot GND as a common terminal.

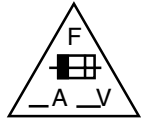

## CAUTION

FOR CONTINUED PROTECTION AGAINST FIRE HAZARD,  
REPLACE ONLY WITH THE SAME TYPE FUSE.  
ATTENTION : POUR UNE PROTECTION CONTINUE LES RISQUES  
D'INCELE N'UTILISER QUE DES FUSIBLE DE MÊME TYPE.  
**RISK OF FIRE-REPLACE FUSE AS MARKED.**



"This symbol means fast operating fuse."

"Ce symbole représente un fusible à fusion rapide."

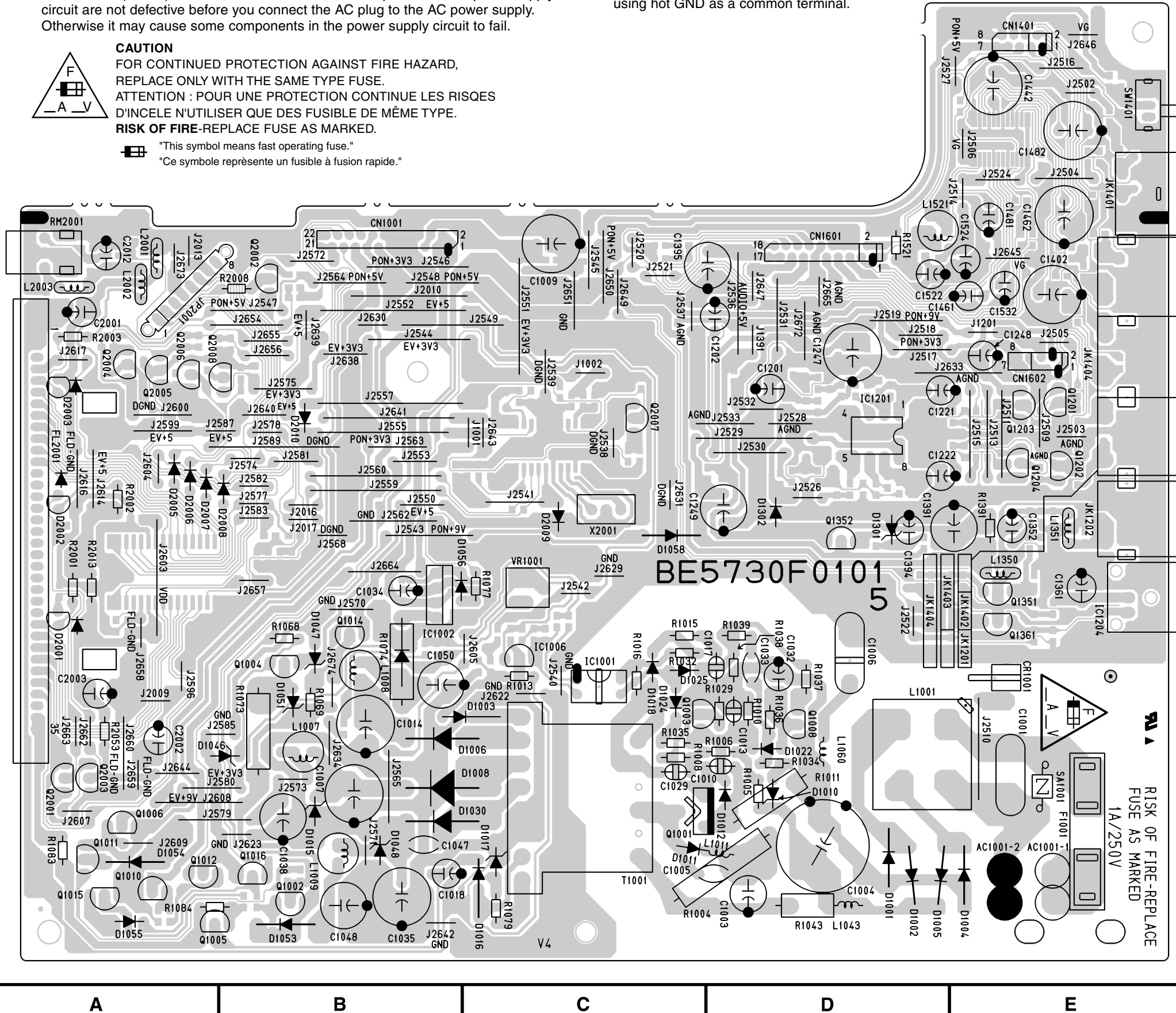

# AV CBA Bottom View

## CAUTION !

Fixed voltage ( or Auto voltage selectable ) power supply circuit is used in this unit.  
If Main Fuse ( F1001 ) is blown, check to see that all components in the power supply circuit are not defective before you connect the AC plug to the AC power supply.  
Otherwise it may cause some components in the power supply circuit to fail.

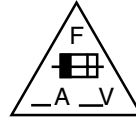

## CAUTION

FOR CONTINUED PROTECTION AGAINST FIRE HAZARD,  
REPLACE ONLY WITH THE SAME TYPE FUSE.  
ATTENTION : POUR UNE PROTECTION CONTINUE LES RISQUES  
D'INCELE N'UTILISER QUE DES FUSIBLE DE MÊME TYPE.  
**RISK OF FIRE-REPLACE FUSE AS MARKED.**

"This symbol means fast operating fuse."  
"Ce symbole représente un fusible à fusion rapide."

## NOTE :

The voltage for parts in hot circuit is measured using hot GND as a common terminal.

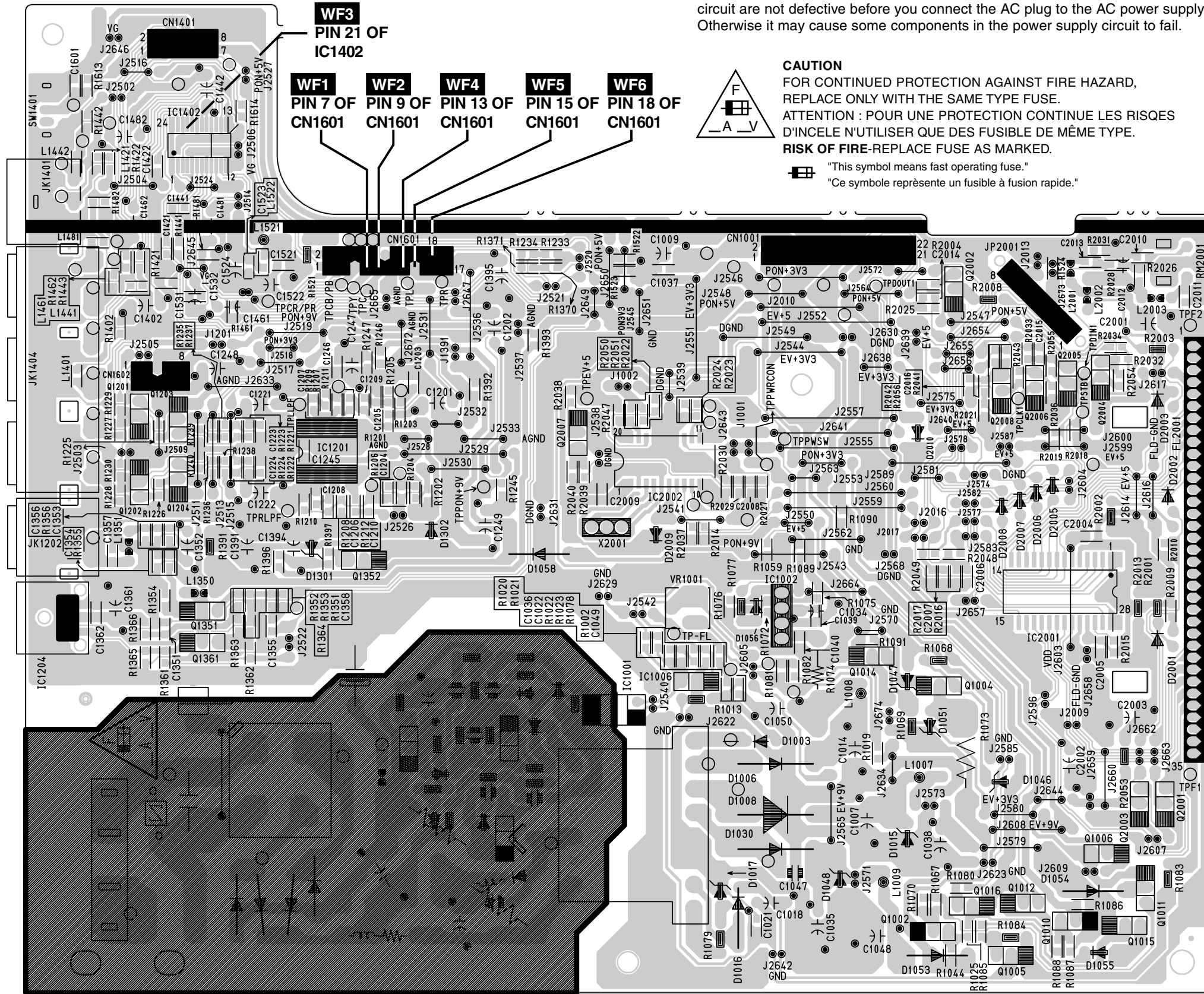

4

3

2

1

E

D

C

B

A



### FUNCTION CBA Top View

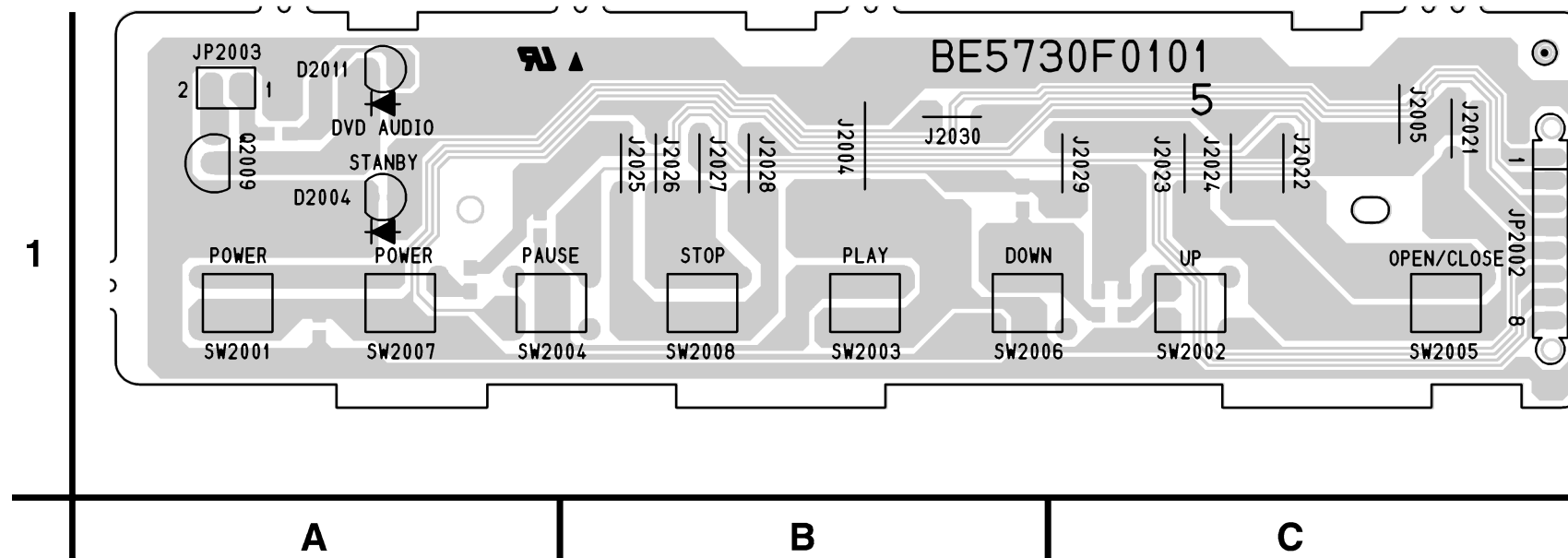

### FUNCTION CBA Bottom View

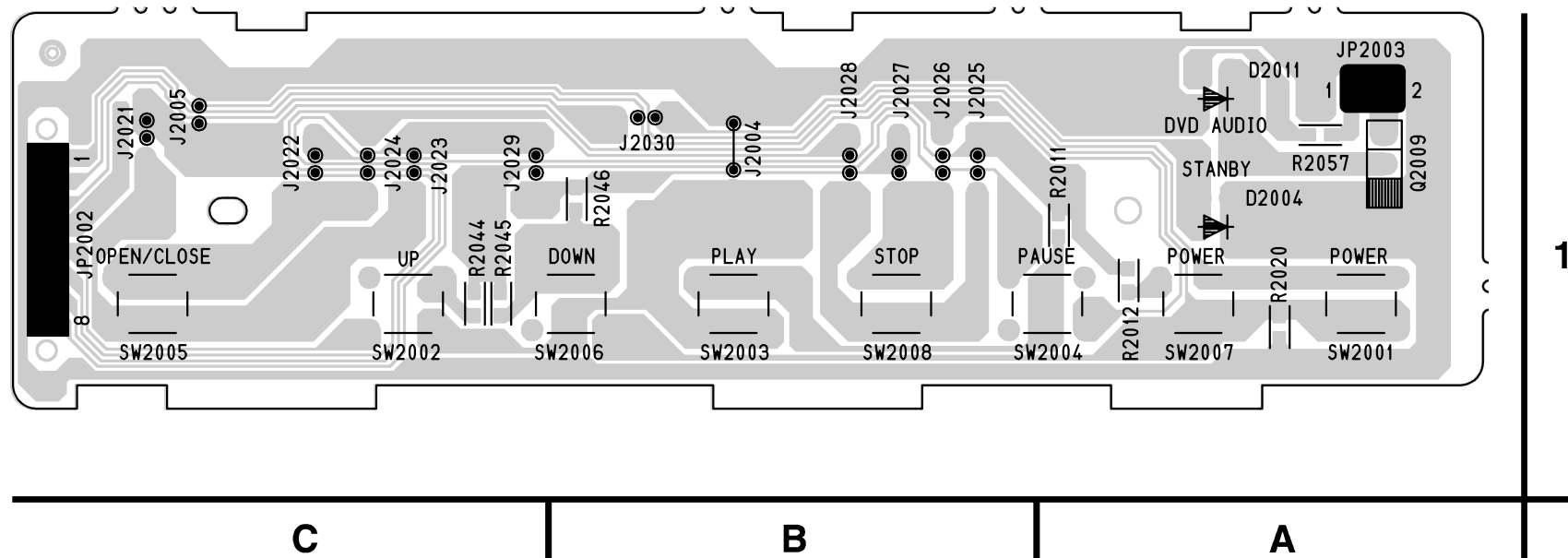

DVD Audio CBA Top View

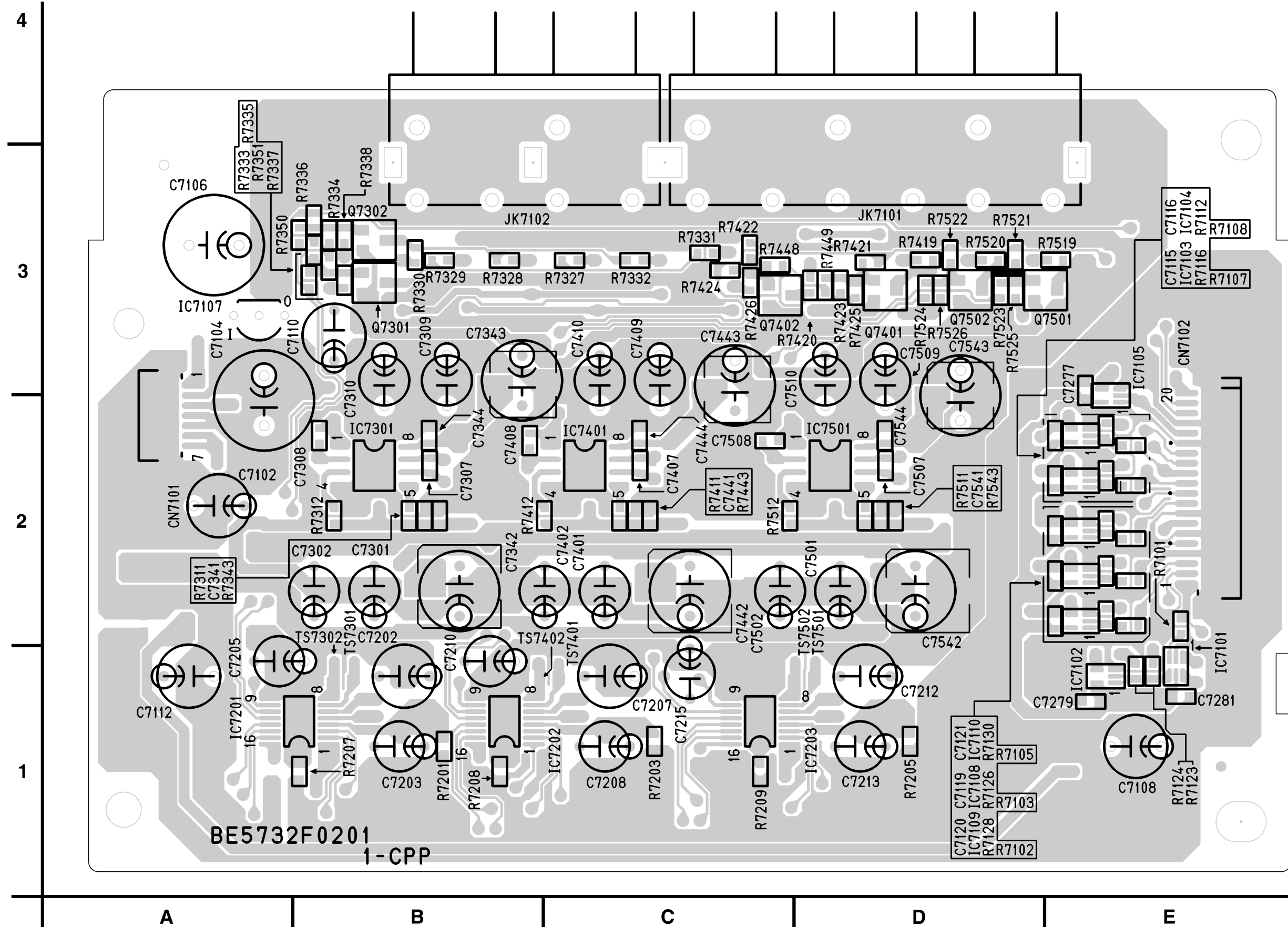

DVD Audio CBA Bottom View

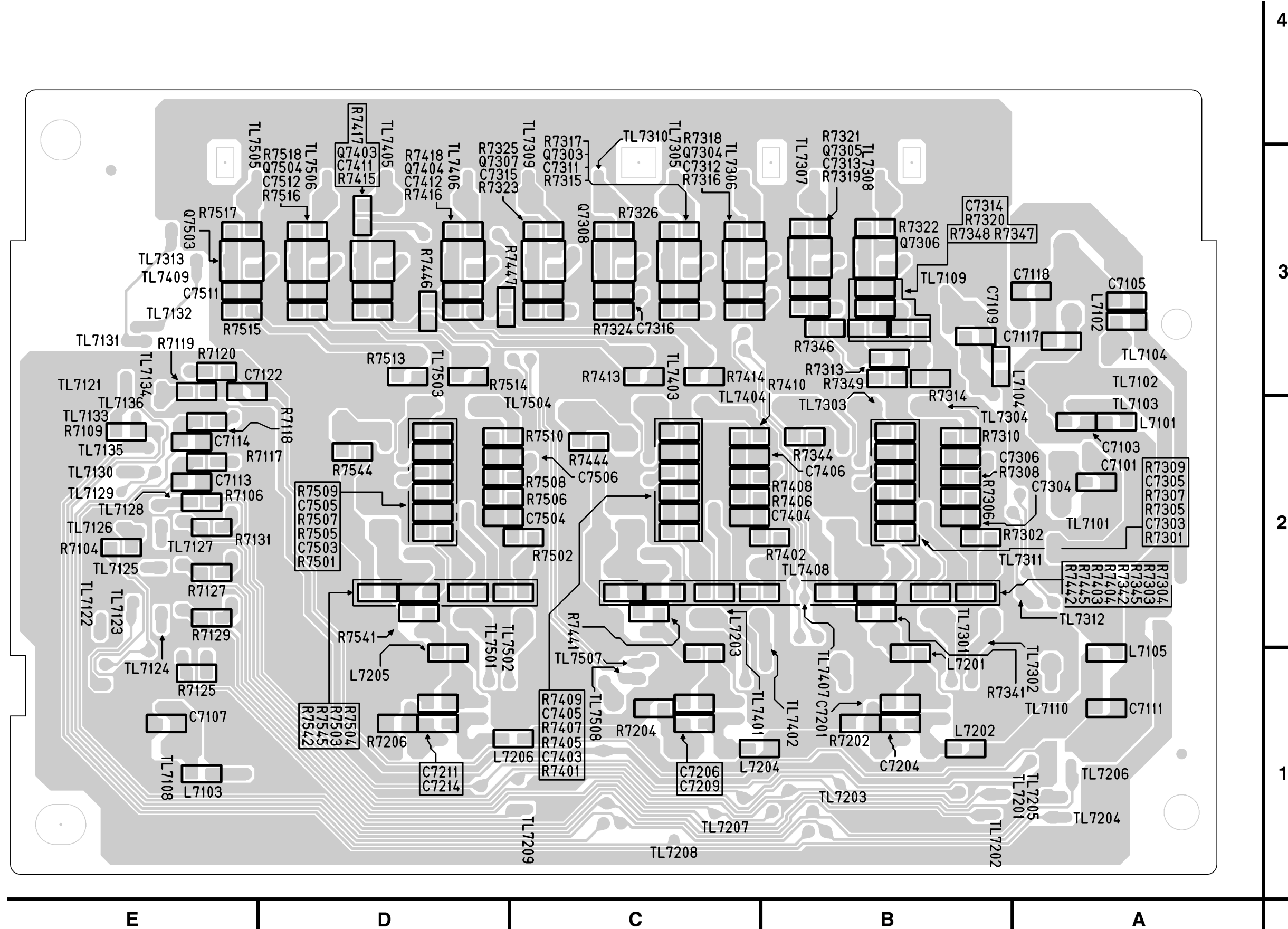

# WAVEFORMS

**WF1** Pin 7 of CN1601

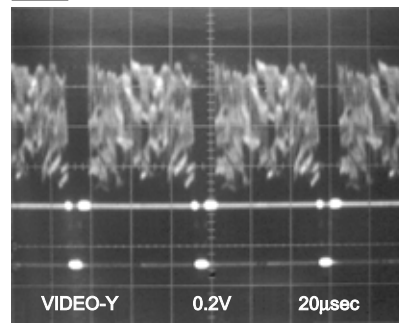

**WF5** Pin 15 of CN1601

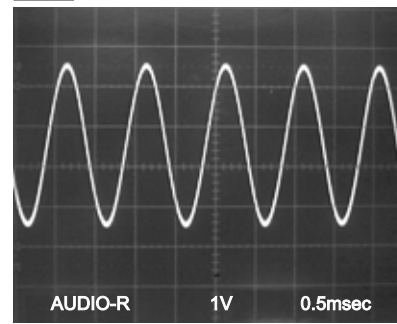

**NOTE:**

Input

CD: 1kHz PLAY  
(WF4~WF6)

DVD: POWER ON (STOP) MODE  
(WF1~WF3)

**WF2** Pin 9 of CN1601

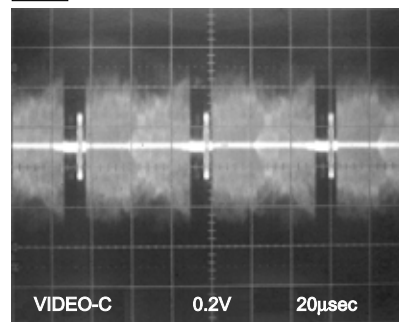

**WF6** Pin 18 of CN1601

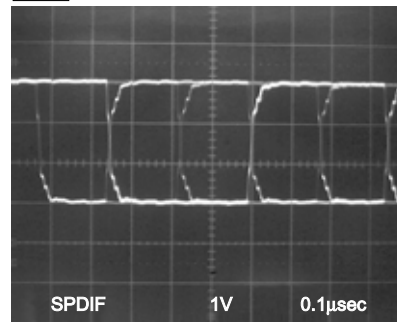

**WF3** Pin 21 of IC1402

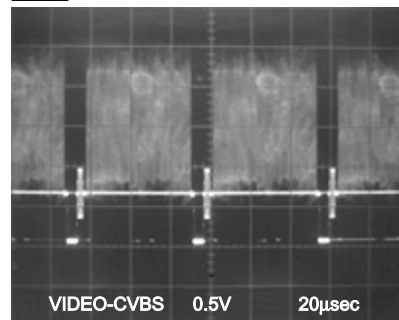

**WF4** Pin 13 of CN1601

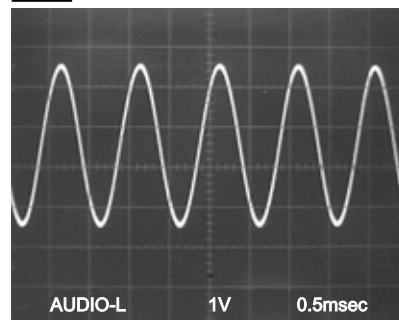

# WIRING DIAGRAM

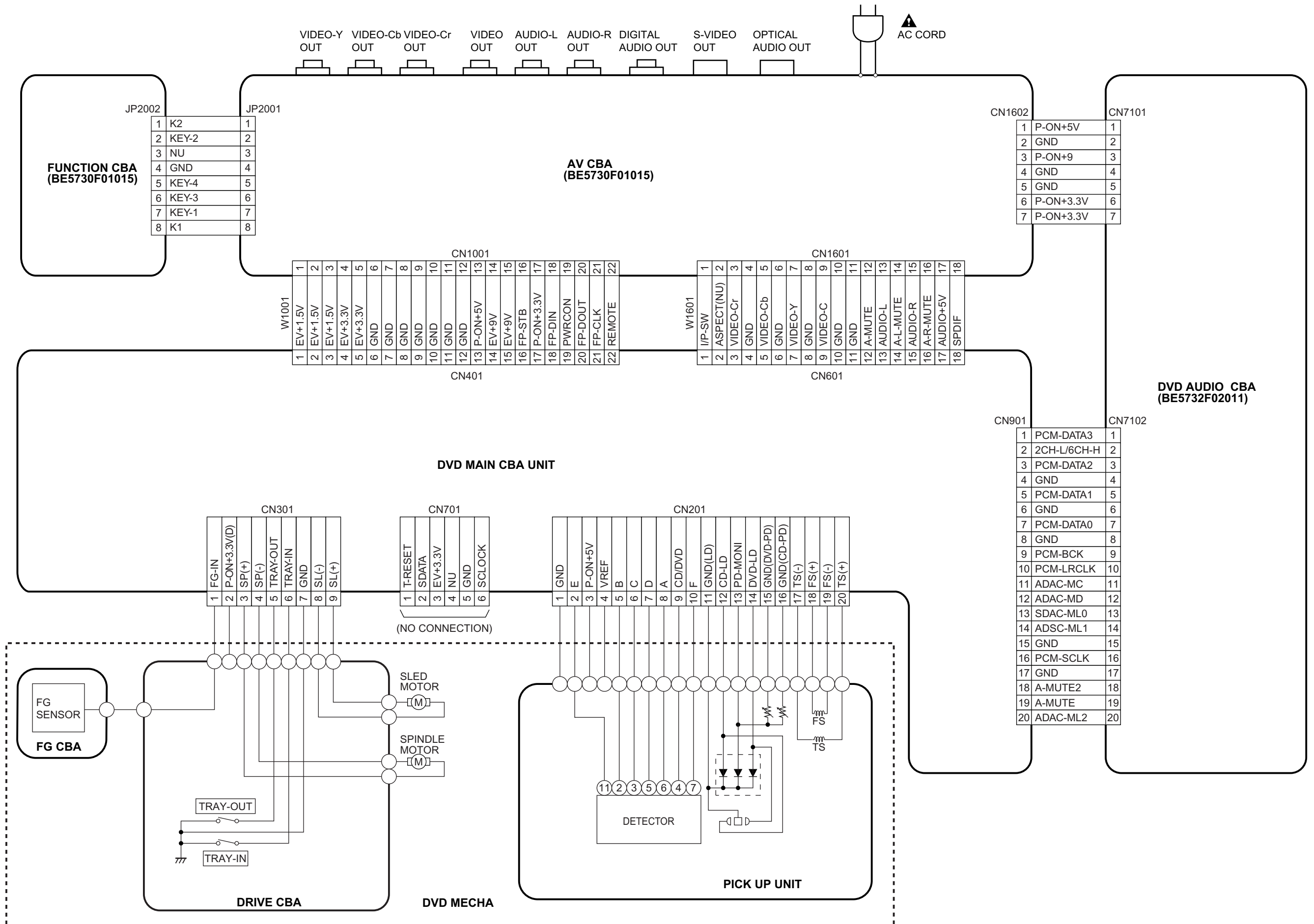

# FIRMWARE RENEWAL MODE

1. Turn the power on and remove the disc on the tray.
2. To put the DVD player into version up mode, press [9], [8], [7], [6], and [SEARCH MODE] buttons on the remote control unit in that order. The tray will open automatically.  
Fig. a appears on the screen and Fig. b appears on the VFD.

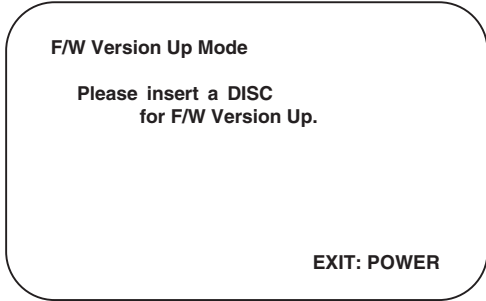

Fig. a Version Up Mode Screen

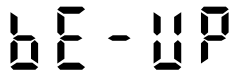

Fig. b VFD in Version Up Mode

The DVD player can also enter the version up mode with the tray open. In this case, Fig. a will be shown on the screen while the tray is open.

3. Load the disc for version up.
4. The DVD player enters the F/W version up mode automatically. Fig. c appears on the screen and Fig. d appears on the VFD.

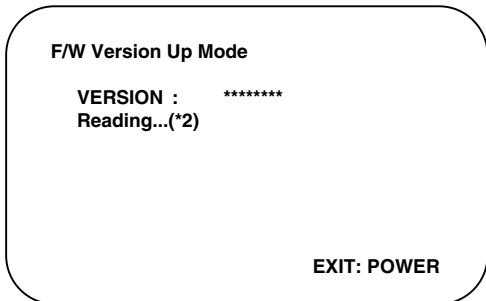

Fig. c Programming Mode Screen



Fig. d VFD in Programming Mode (Example)

The appearance shown in (\*2) of Fig. c is described as follows:

No.	Appearance	State
1	Reading...	Sending files into the memory
2	Erasing...	Erasing previous version data
3	Programming...	Writing new version data

5. After programming is finished, the tray opens automatically. Fig. e appears on the screen and the checksum in (\*3) of Fig. e appears on the VFD. (Fig. f)

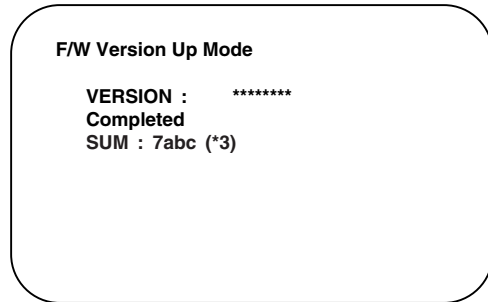

Fig. e Completed Program Mode Screen



Fig. f VFD upon Finishing the Programming Mode (Example)

At this time, no buttons are available.

6. Unplug the AC cord from the AC outlet. Then plug it again.
7. Turn the power on by pressing the power button and the tray will close.
8. Press [1], [2], [3], [4], and [DISPLAY] buttons on the remote control unit in that order.  
Fig. g appears on the screen.

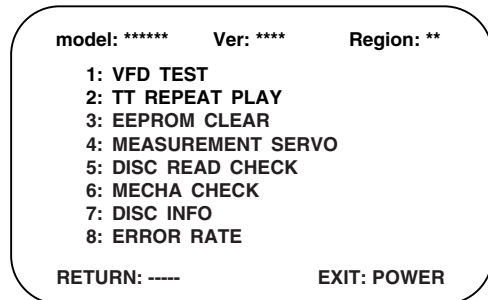

Fig. g

9. Press [3] button on the remote control unit.  
Fig. h appears on the screen.

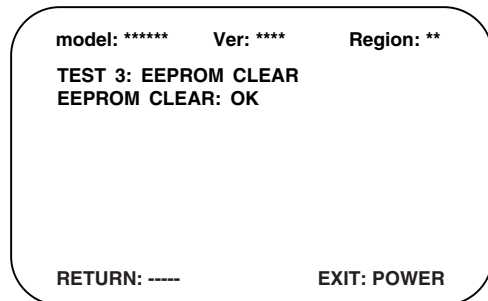
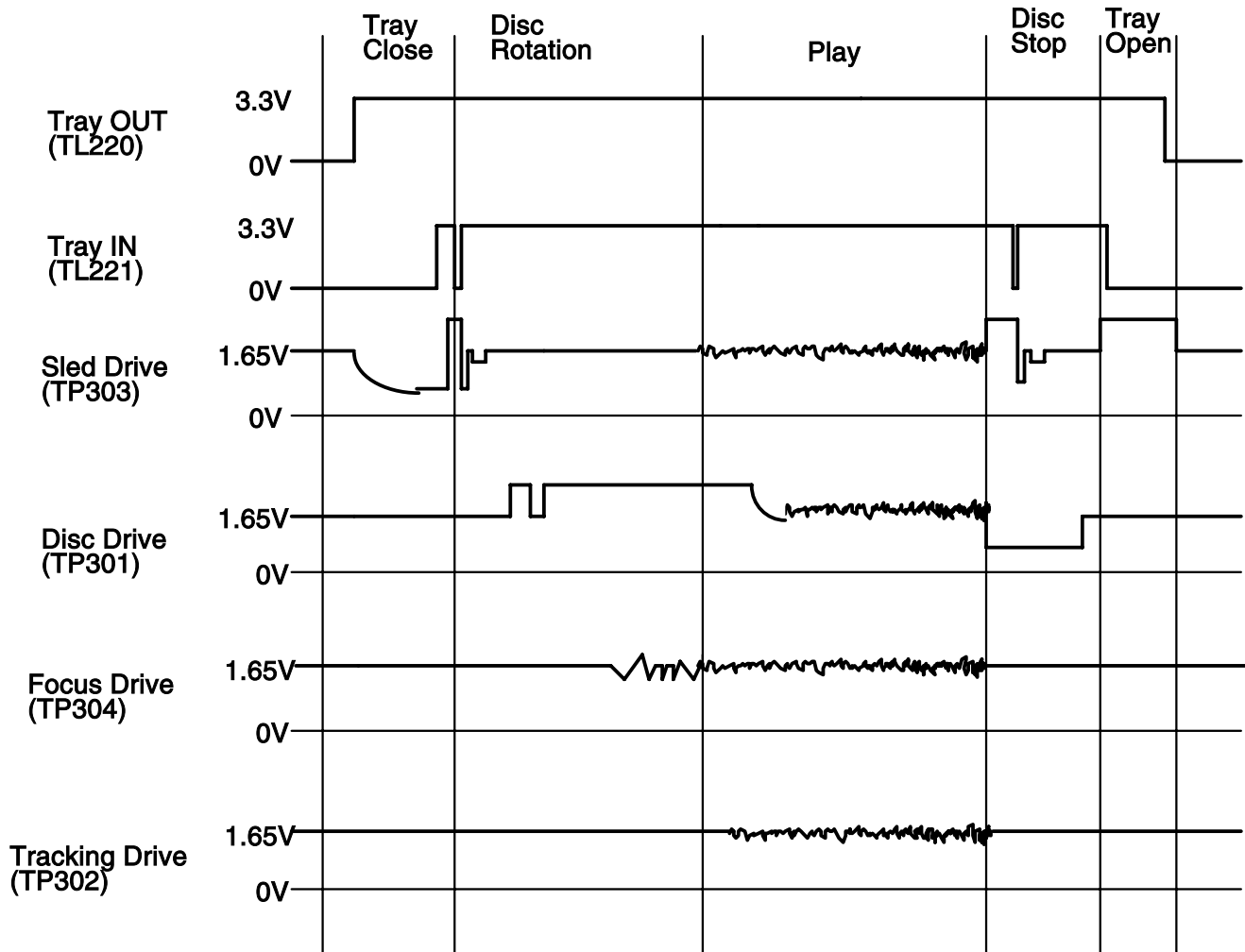

Fig. h

10. To exit this mode, press [POWER] button.

# SYSTEM CONTROL TIMING CHARTS

Tray Close ~ Play / Play ~ Tray Open



# IC PIN FUNCTION DESCRIPTIONS

## IC2001 [ PT6313-S-TP ]

Pin No.	In/Out	Signal Name	Name Function
1	In	FP-CLK	Clock Input
2	In	FP-STB	Serial Interface Strobe
3	In	K1	Key Data 1 Input
4	In	K2	Key Data 2 Input
5	-	VSS	GND
6	-	VDD	Power Supply
7	Out	a / KEY-1	Segment Output / Key Source-1
8	Out	b / Key-2	Segment Output / Key Source-2
9	Out	c / Key-3	Segment Output / Key Source-3
10	Out	d / Key-4	Segment Output / Key Source-4
11	Out	e	Segment Output
12	In	f	
13	In	g	
14	Out	h	
15	-	VEE	Pull Down Level
16	Out	i	Segment Output
17	Out	7G	Grid Output
18		6G	
19		5G	
20		4G	
21		3G	
22		2G	
23		1G	
24	-	VDD	Power Supply
25	-	VSS	GND
26	In	OSC	Oscillator Input
27	Out	FP-DOUT	Serial Data Output
28	In	FP-DIN	Serial Data Input



# LEAD IDENTIFICATIONS

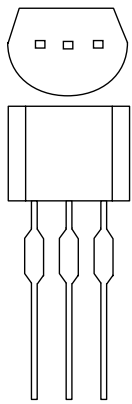

2SA1015-Y (TPE2)  
KTA1266 (Y)  
KTC3198 (Y)  
2SC2120-Y(TPE2)

E C B

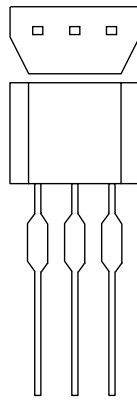

2SC2785 (H)  
KTC3199 (GR)  
KRA110M  
KTA1267 (Y)  
BN1L3Z (P)

E C B

2SK3374

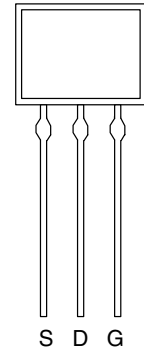

S D G

PCM1751DBQR

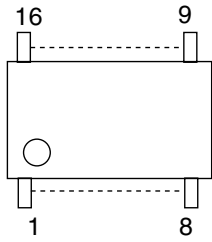

MM1622XJBE

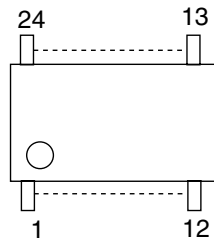

PT6313-S-TP

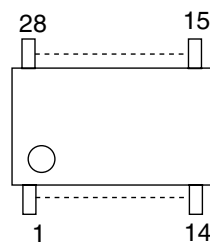

KIA431-AT

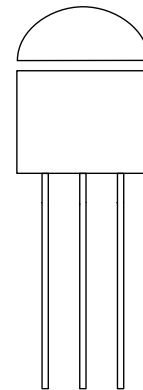

K A R

NC7SB3157P6X

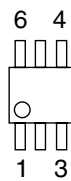

LTV-817(B,C)-F



PQ070XF01SZ

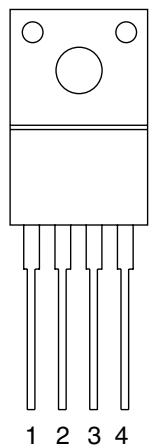

1: Vin  
2: Vo  
3: GND  
4: Vc

1 2 3 4

NJM4558D  
KIA4558P  
NJM4580M-TE1

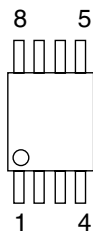

1 4

2SA1037AK T146Q  
KTA1504Y-RTK  
2SC2412K T146S  
KTC3875GR-RT

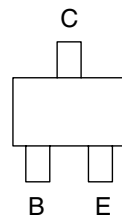

B E

0C-0805T\*002  
GP1FA513TZ

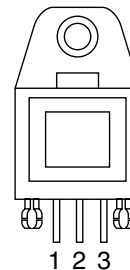

1 2 3

**Note:**

- A: Anode
- K: Cathode
- E: Emitter
- C: Collector
- B: Base
- R: Reference
- G: Gate
- D: Drain
- S: Source

# EXPLODED VIEWS

## Cabinet

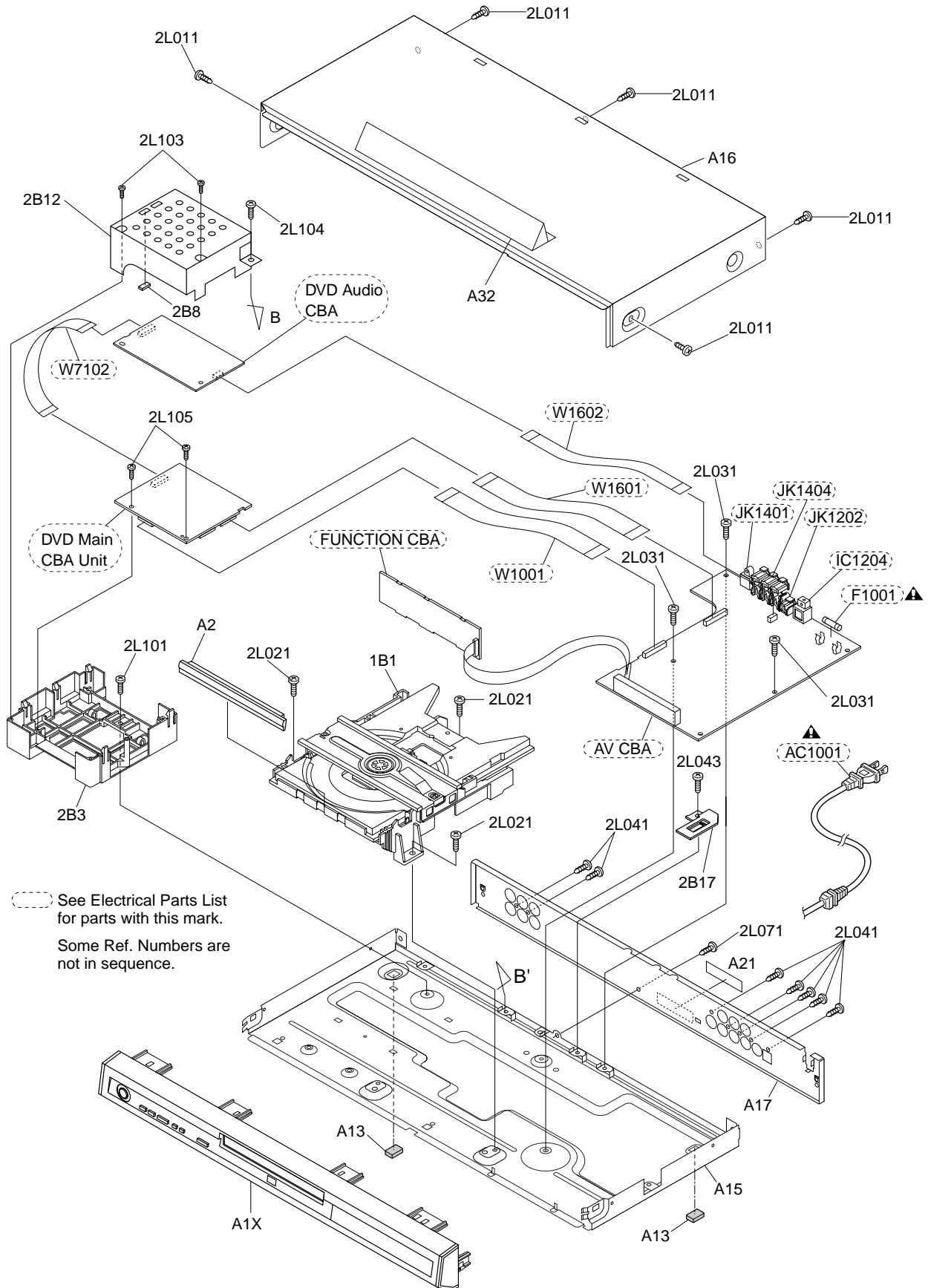

# PARTS LIST

<b>Part Number</b>	<b>Description</b>
I/B DD7040	OWNER'S GUIDE
NA016UD	REMOTE
N79F1GVM	MECHA-PU
N79MCGUP	PCB-MAIN (DD-7040)
OVM204133	FRONT-ASSY
OVM306091	COVER-TOP
OVSA14121	PCB-ASSY (AV & FUNCTION)
OVSA14124	PCB-AUDIO (DD-7040/DD-8040)