



Service Manual

DVD Player

Model

DD-8030



CAUTION

Before servicing this chassis, it is important that the service person reads all SAFETY PRECAUTIONS and the SAFETY NOTICE in this manual.

SPECIFICATIONS

Power Supply:	120V AC, 60 Hz	Operating conditions:	Temperature: 5°C to 35°C
Power Consumption:	17W	Operation status:	Horizontal
Weight:	5.6 lb.	Video output:	1.0 V (p-p), 75Ω, negative sync., pin jack x 1
External Dimensions:	17"x 2-3/4"x8-7/8" (W/H/D)	S Video output:	(Y) 1.0 V (p-p), 75Ω, negative sync., Mini DIN 4-pin x 1 (C) 0.286 V (p-p), 75Ω
Signal System:	Standard NTSC	Component Video output:	(Y) 1.0 V (p-p), 75Ω, negative sync., pin jack x 1 (Cr, Pr)/(Cb, Pb) 0.7 V (p-p), 75Ω, pin jack x 2
Laser:	Semiconductor laser, wavelength 650nm/780nm (Digital Audio)	Digital Audio output:	(Bitstream/PCM) 0.5 V (p-p), 75Ω, pin jack x 1, Optical connector x 1
Frequency Range:		Analog Audio output:	2.0 V (rms), 680Ω, pin jack 2 CH L R x 2, 5.1 CH SURROUND x 6
DVD Linear -			
48 kHz Sampling:	4 Hz to 22 kHz		
96 kHz Sampling:	4 Hz to 44 kHz		
Signal-To-Noise Ratio:	More than 112 dB (EIAJ)		
Audio Dynamic Range:	More than 108 dB (EIAJ)		
Harmonic Distortion:	Less than 0.002%		
Wow and flutter:	Below measurable level (less than ± 0.001% (W.PEAK)) (EIAJ)		

MITSUBISHI DIGITAL ELECTRONICS AMERICA, INC.

9351 Jeronimo Rd. Irvine, CA 92618

Copyright © 2002 Mitsubishi Digital Electronics America, Inc.

All Rights Reserved

SECTION 1

GENERAL DESCRIPTIONS

1. PREPARATION FOR SERVICING

The Pickup Head consists of a laser diode that is very susceptible to external static electricity.

Although it may operate properly after replacement, if subjected to electrostatic discharge during replacement, its life might be shortened. When replacing the laser diode, LSI's and IC's, use a conductive mat, soldering iron with ground wire, etc. to protect against damage from static electricity.

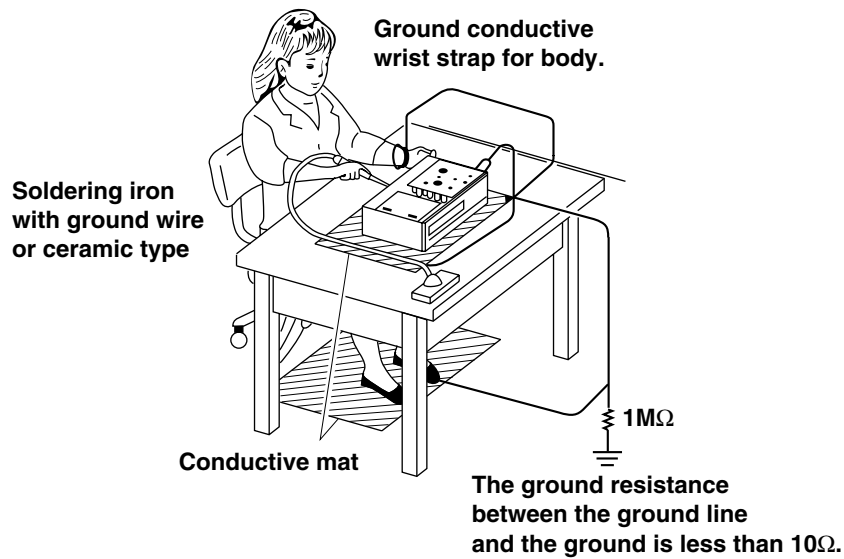

2. LOCATION OF MAIN PARTS AND MECHANISM PARTS

2-1. Location of Main Parts

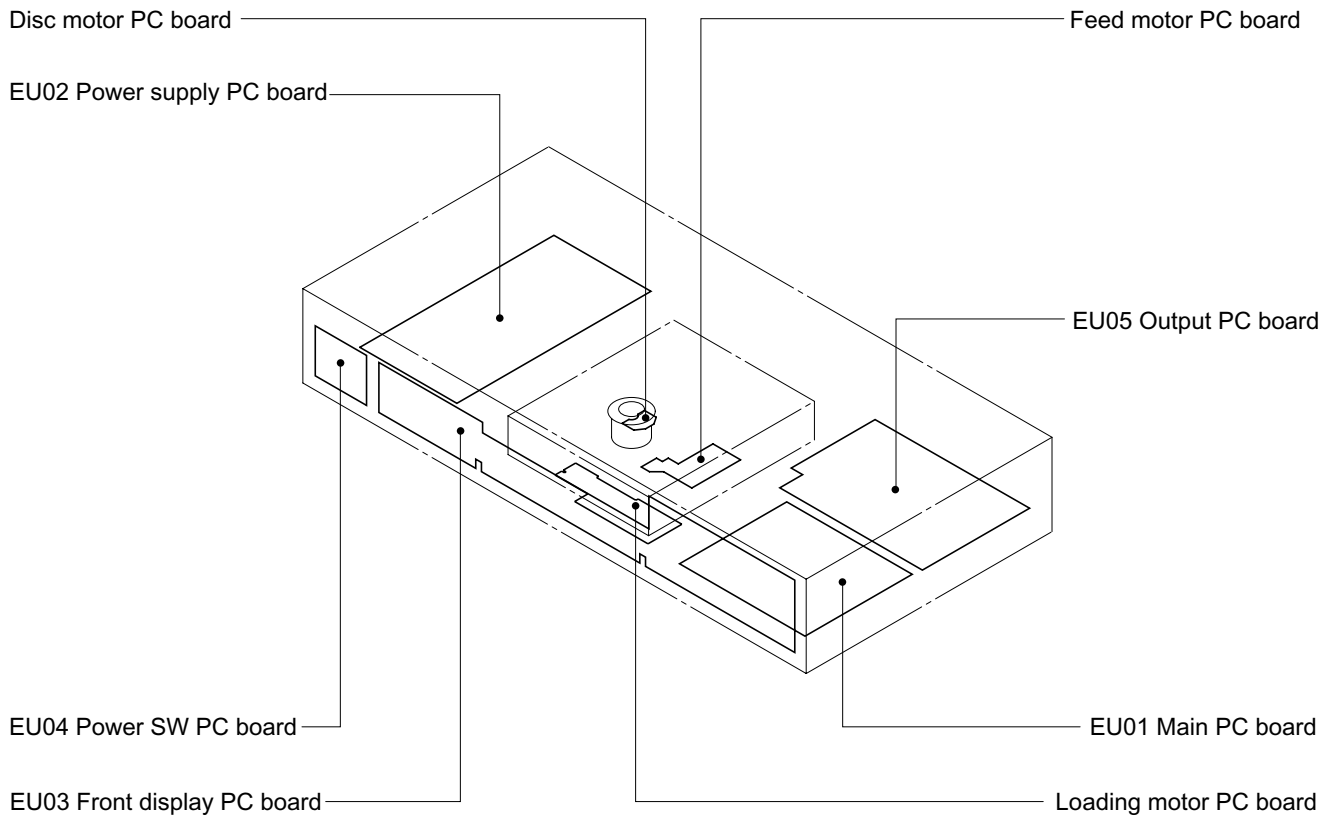

Fig. 1-2-1

2-2. Location of Mechanism Parts

2-2-1. Type A

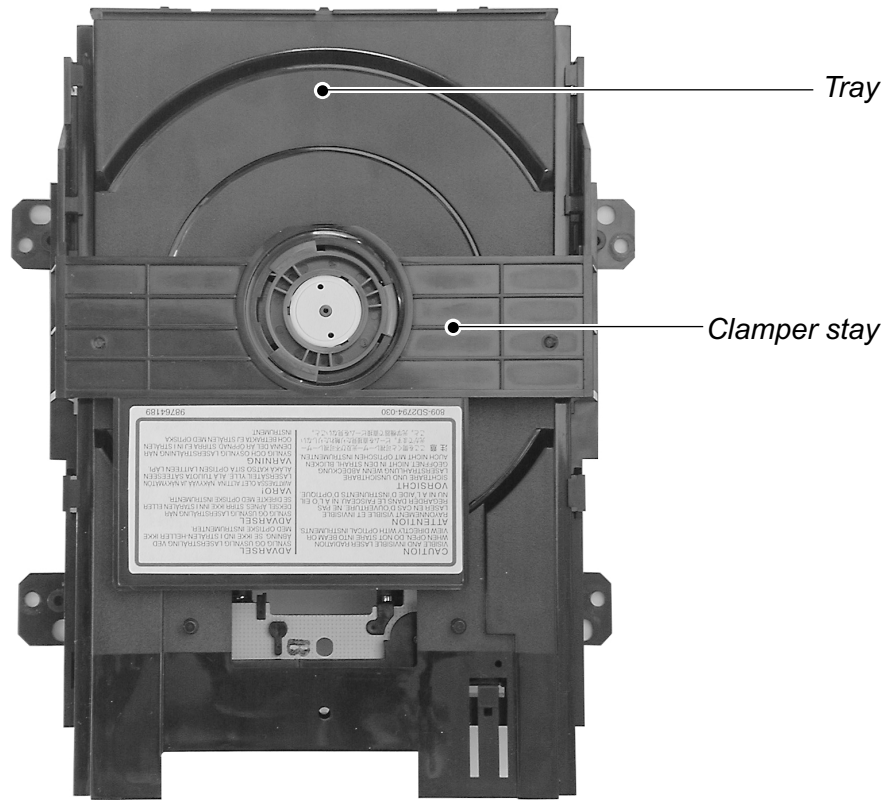

Fig. 1-2-2 Mechanism chassis assembly (Top side)

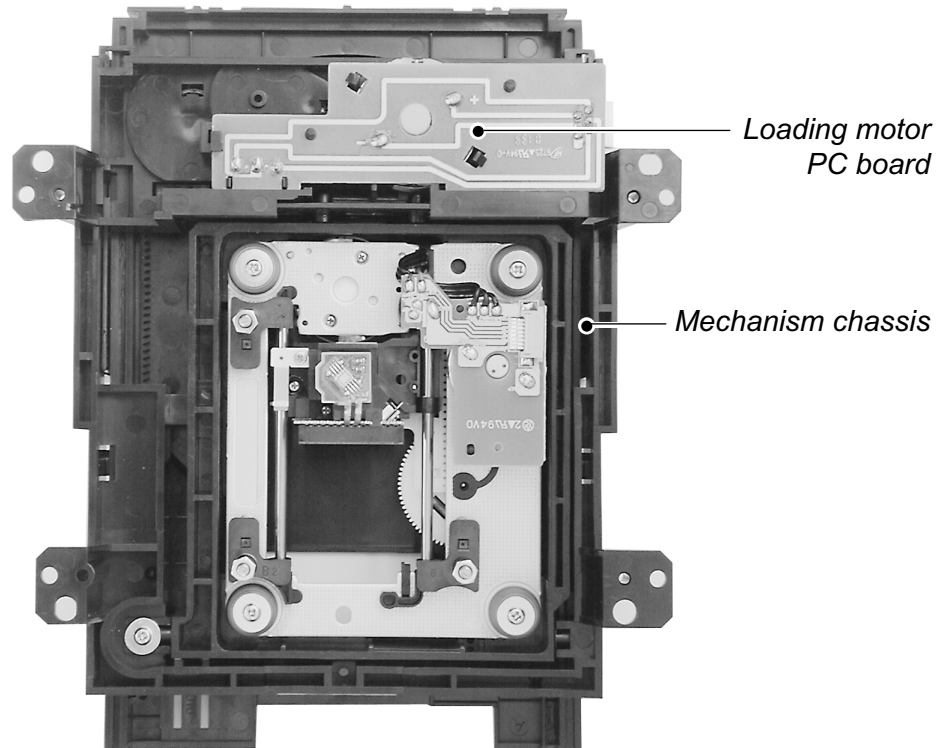

Fig. 1-2-3 Mechanism chassis assembly (Bottom side)

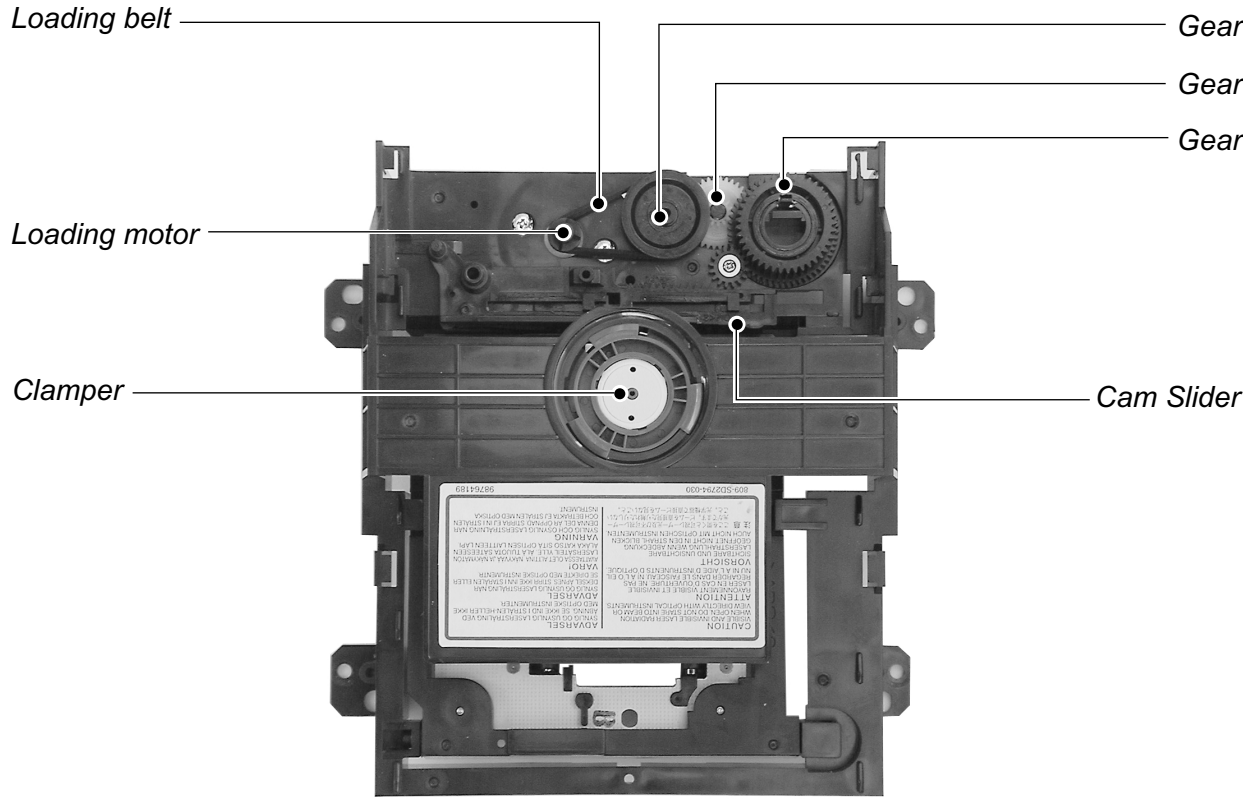

Fig. 1-2-4 Mechanism chassis assembly (Internal side)

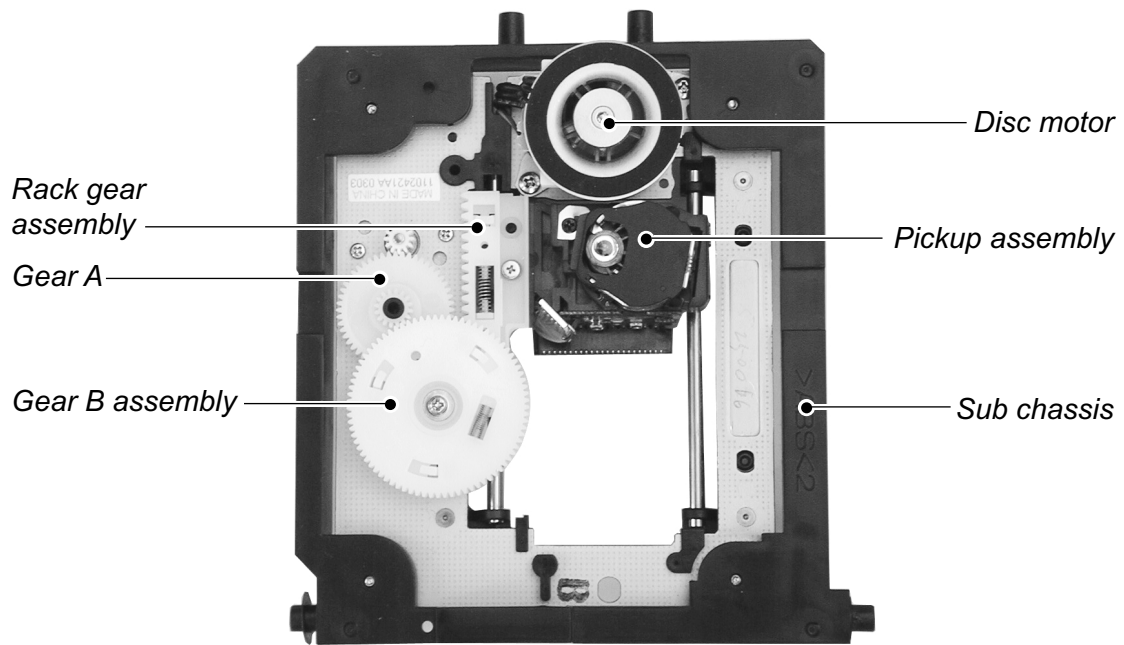

Fig. 1-2-5 Pickup mechanism chassis assembly (Top side)

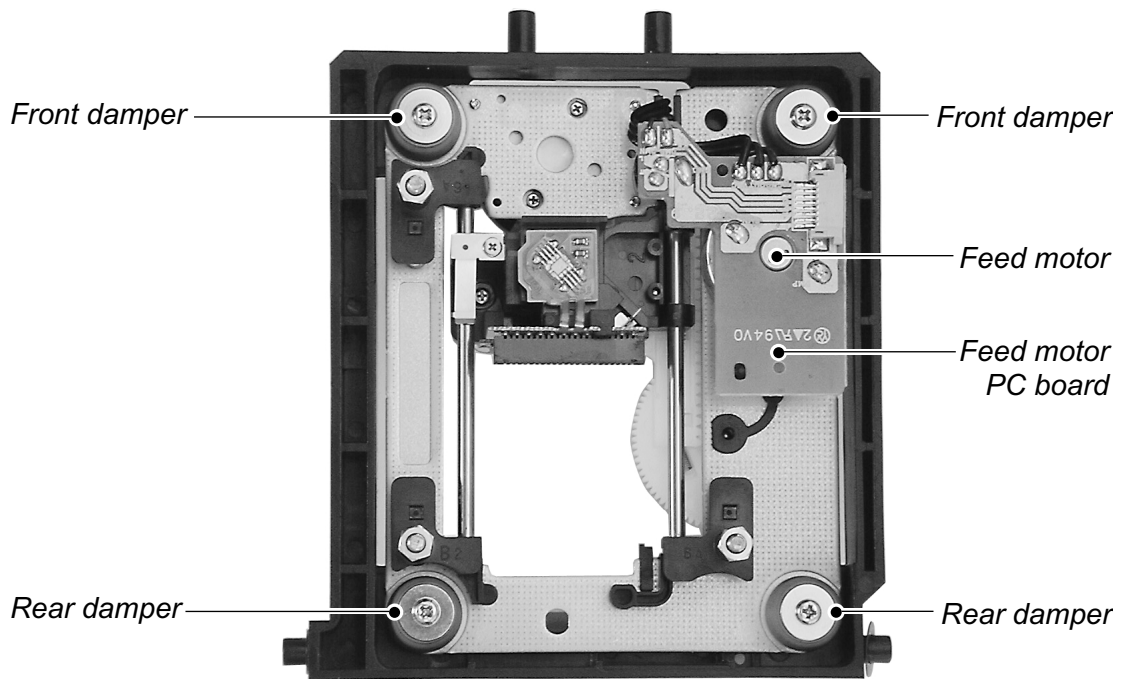

Fig. 1-2-6 Pickup mechanism chassis assembly (Bottom side)

2-2-2. Type B

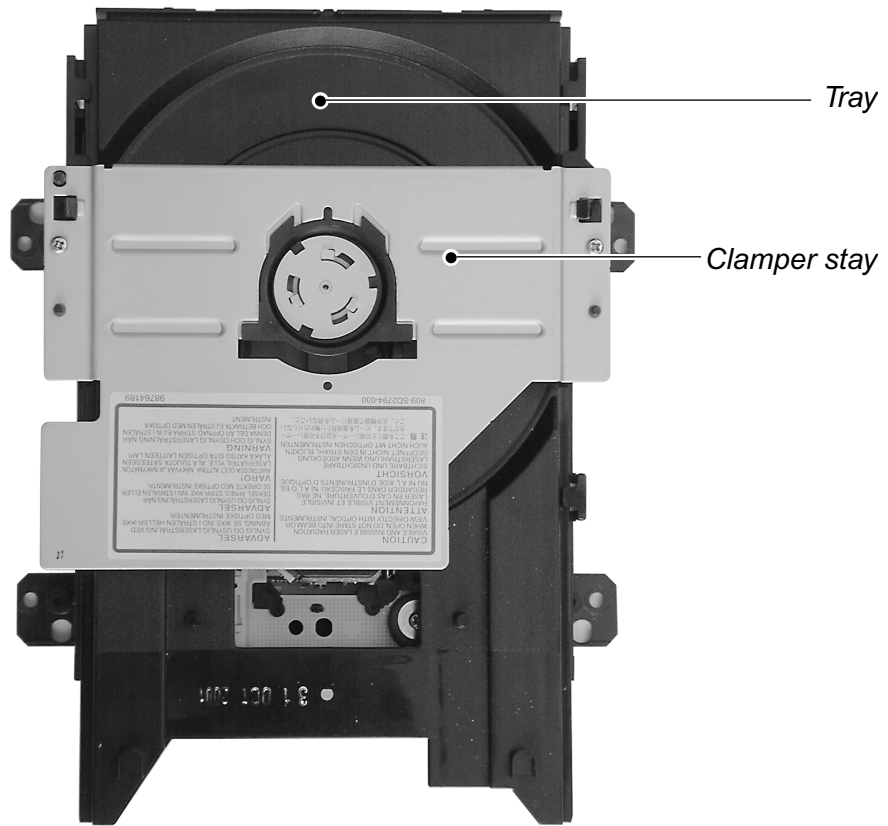

Fig. 1-2-7 Mechanism chassis assembly (Top side)

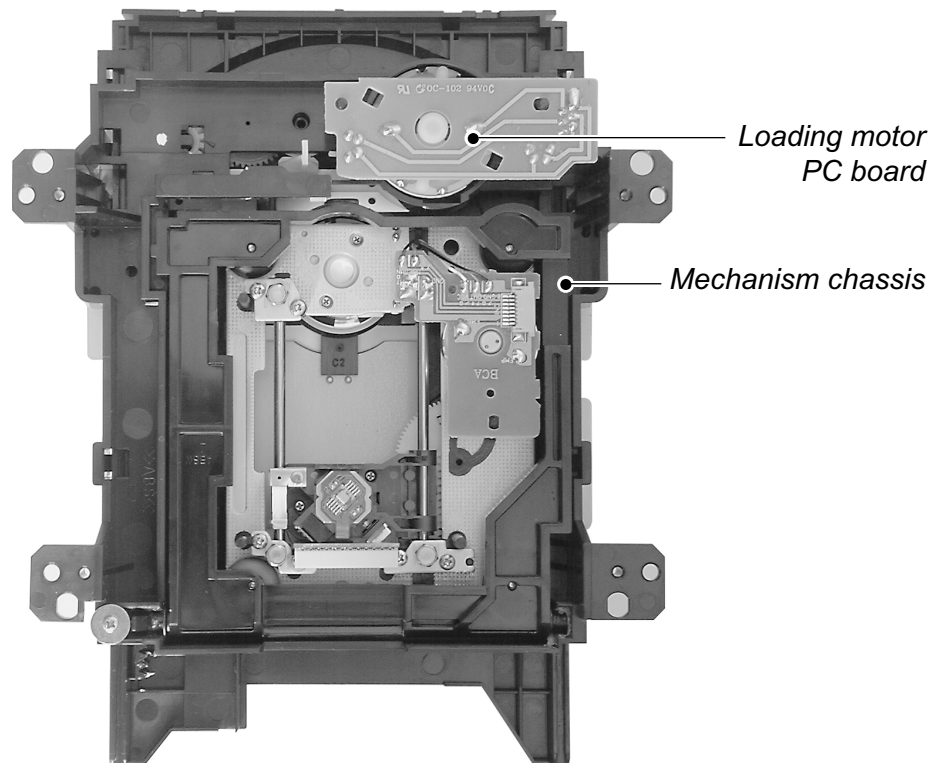

Fig. 1-2-8 Mechanism chassis assembly (Bottom side)

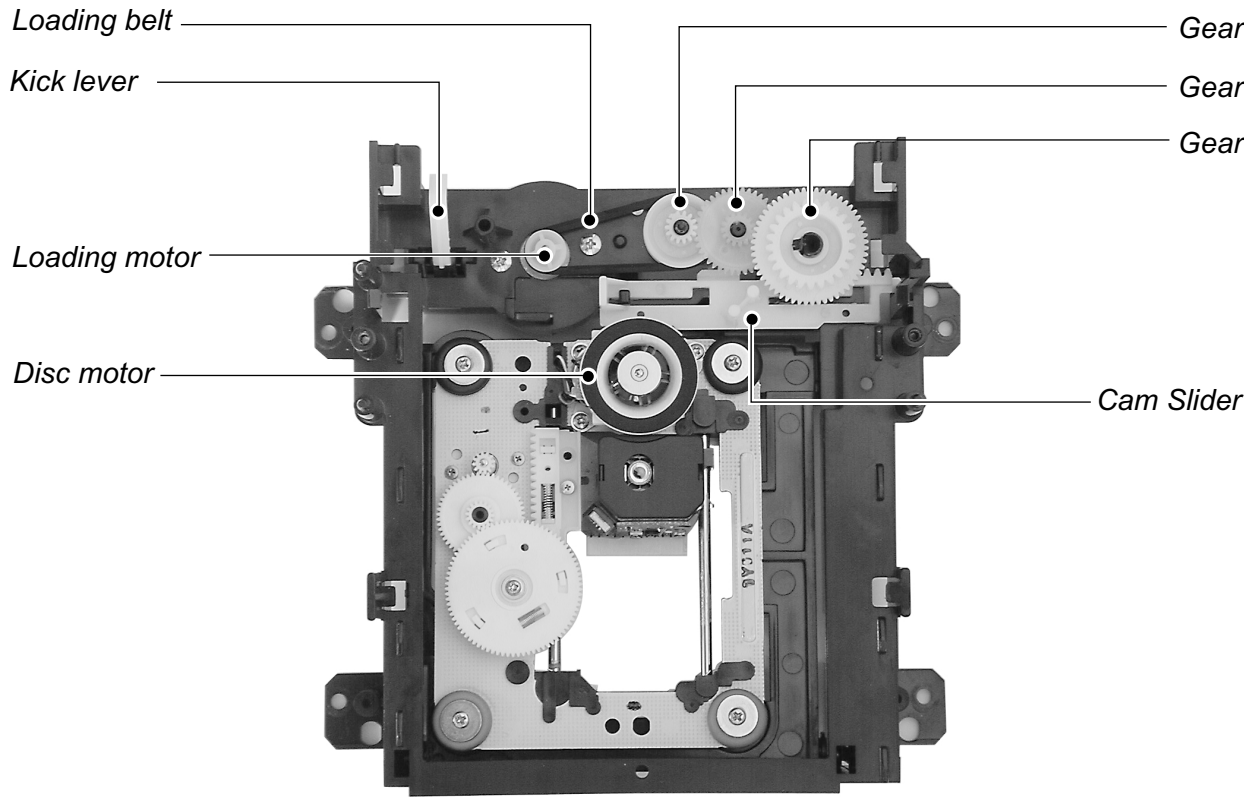

Fig. 1-2-9 Mechanism chassis assembly (Internal side)

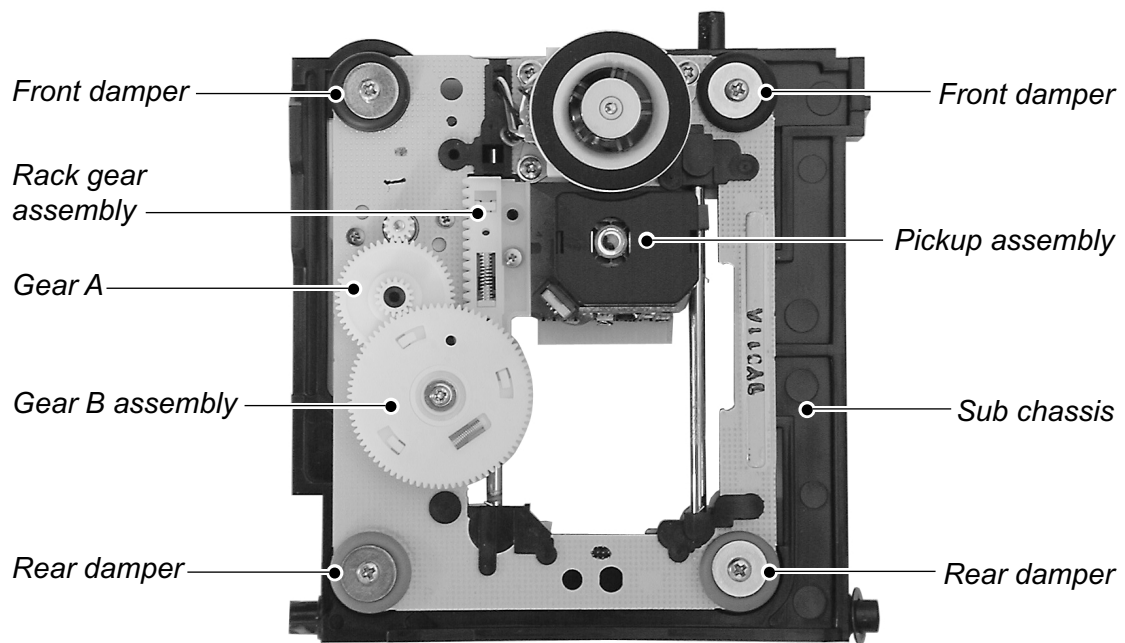

Fig. 1-2-10 Pickup mechanism chassis assembly (Top side)

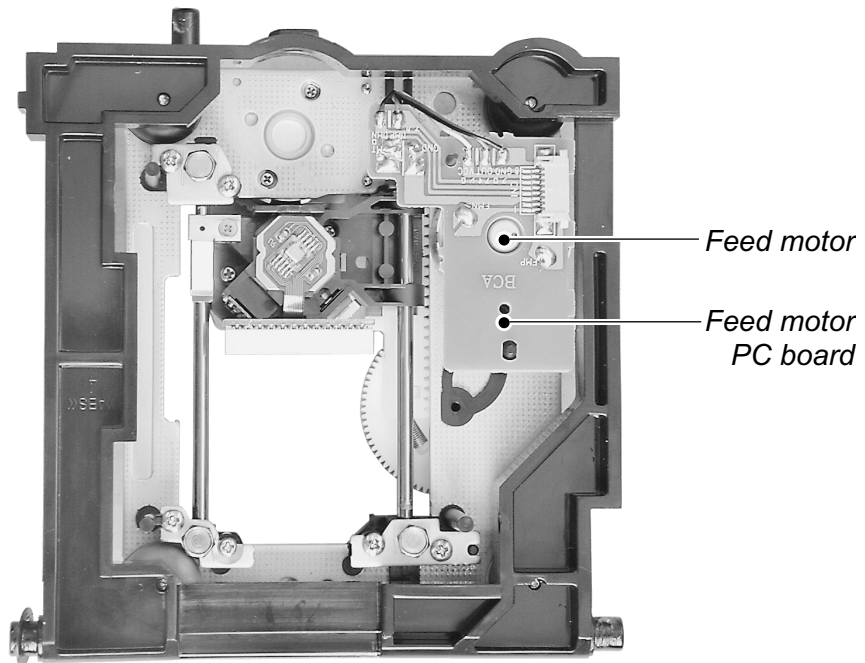

Fig. 1-2-11 Pickup mechanism chassis assembly (Bottom side)

3. TROUBLESHOOTING

3-1. Main Circuit

3-1-1. Servo System

(1) Initial Operation after Power ON

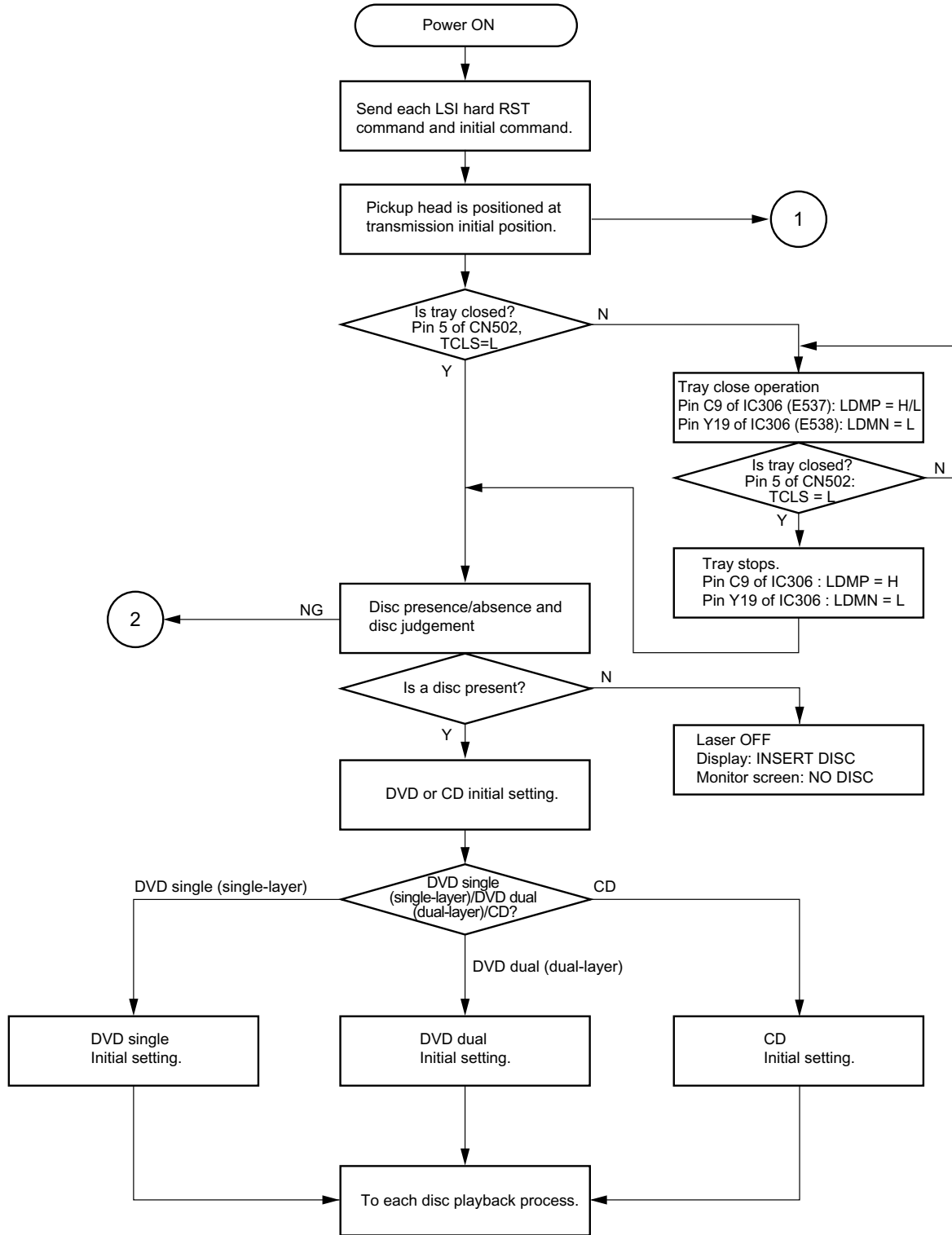

Fig. 1-3-1

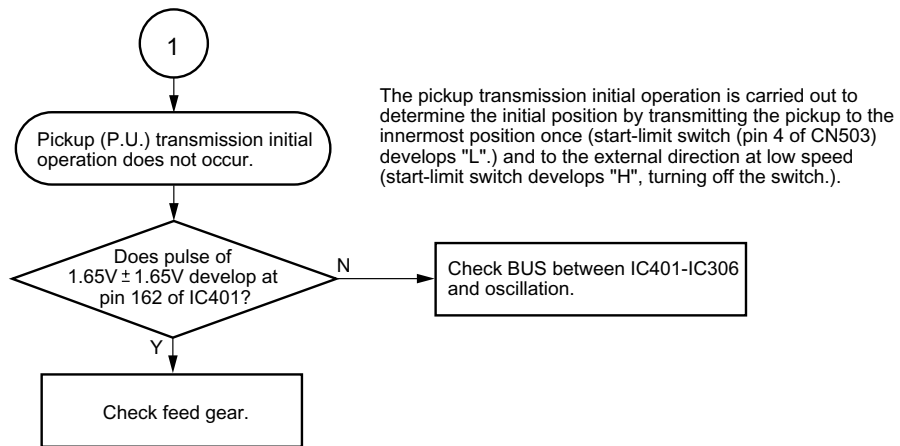

Fig. 1-3-2

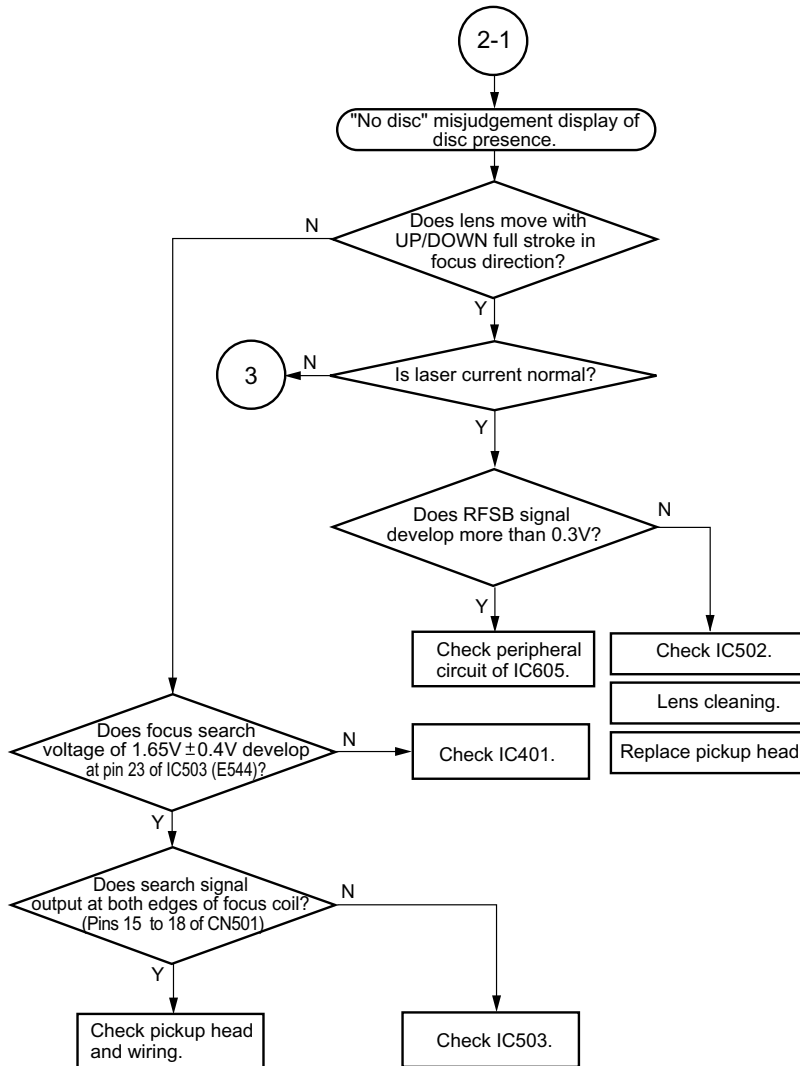

Fig. 1-3-3

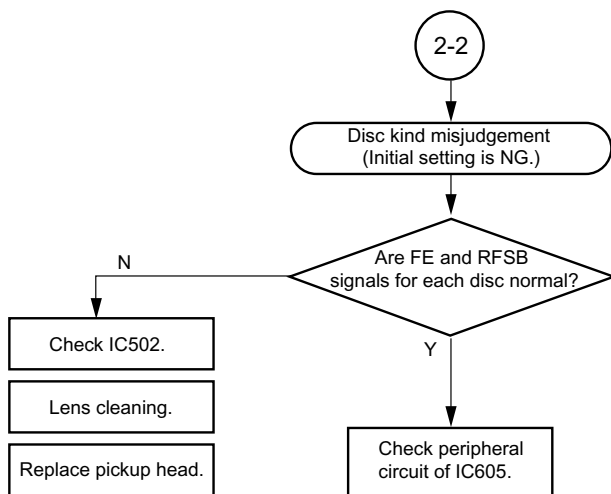
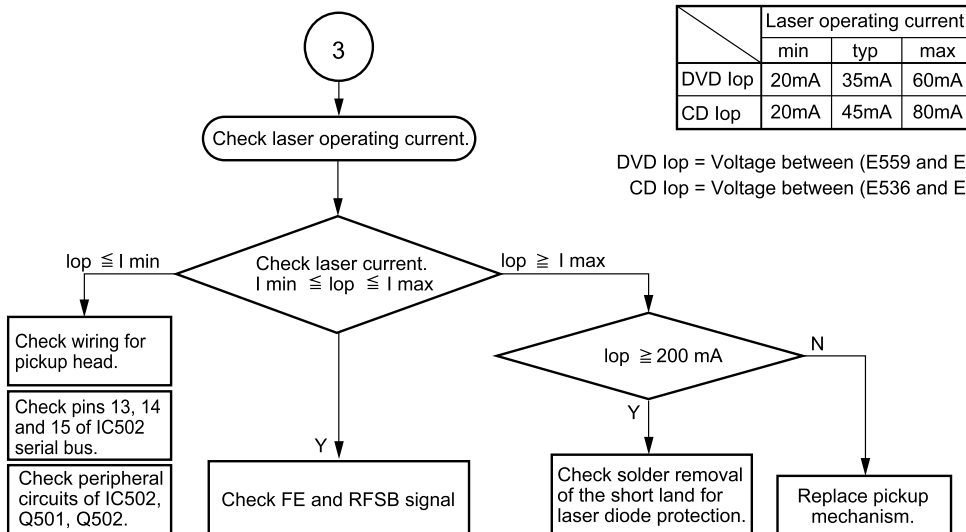

Fig. 1-3-4



To turn on each laser diode forcibly, press the following buttons on the remote controller.

DVD LD: ZOOM, 0, 3, 0, ZOOM

CD LD: ZOOM, 0, 3, 1, ZOOM

After checked the laser current, press POWER or OPEN/CLOSE button to turn it off.

CAUTION

- The laser ray emitting out from the pickup head is very harmful to your eyes. Keep your eyes from the objective lens at least 300mm distance during the pickup head operating.
- When you perform solder removal work, please turn OFF a set power supply and perform the ground of human body and a tool.

Fig. 1-3-5

DVD single (single-layer) disc
detection waveform

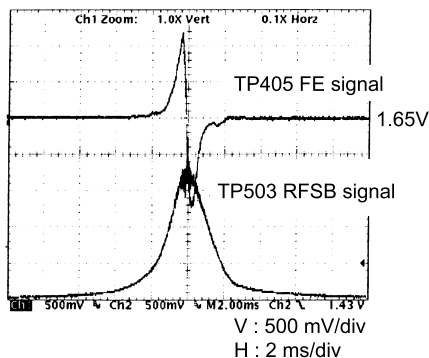

Fig. 1-3-6

DVD dual (dual-layer) disc
detection waveform

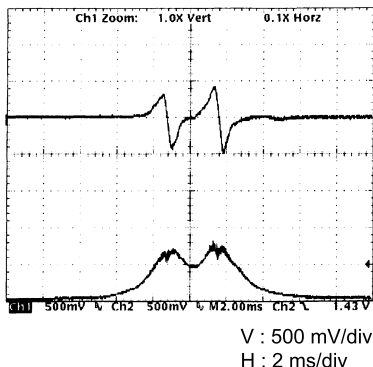

Fig. 1-3-7

CD disc
detection waveform

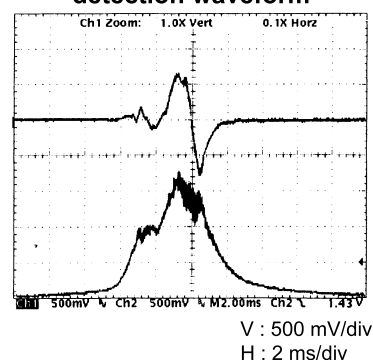

Fig. 1-3-8

(2) Picture appears (PLAY)

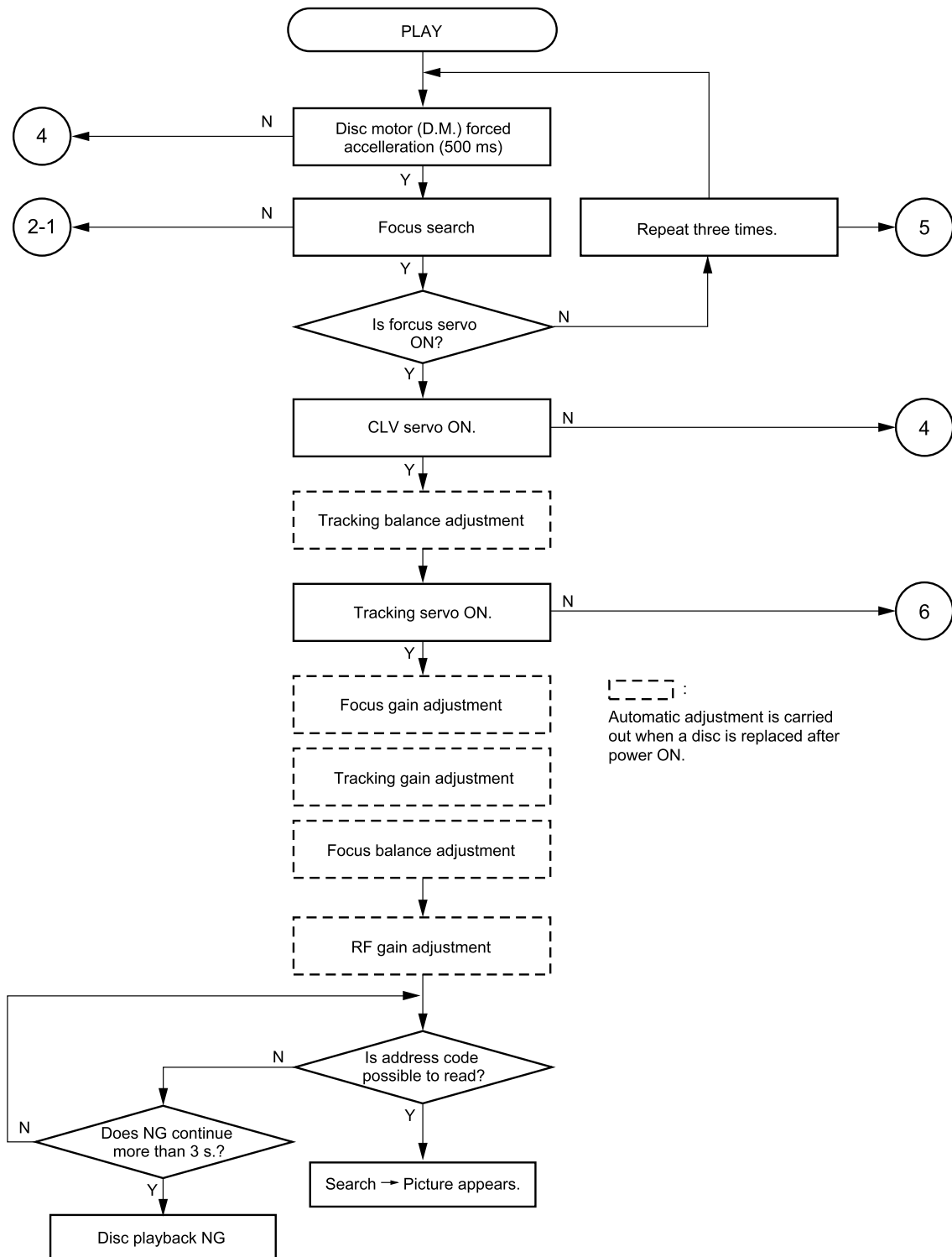

Fig. 1-3-9

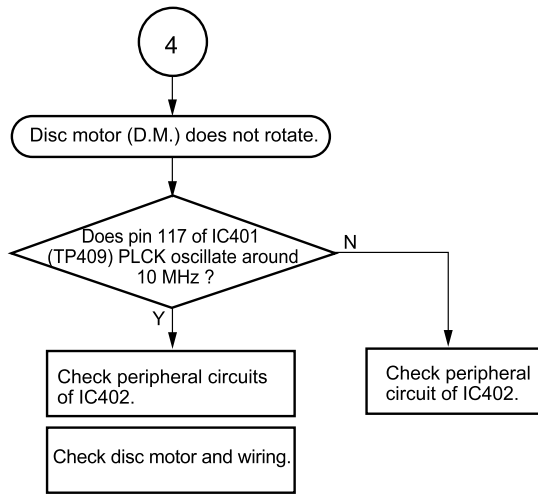

Fig. 1-3-10

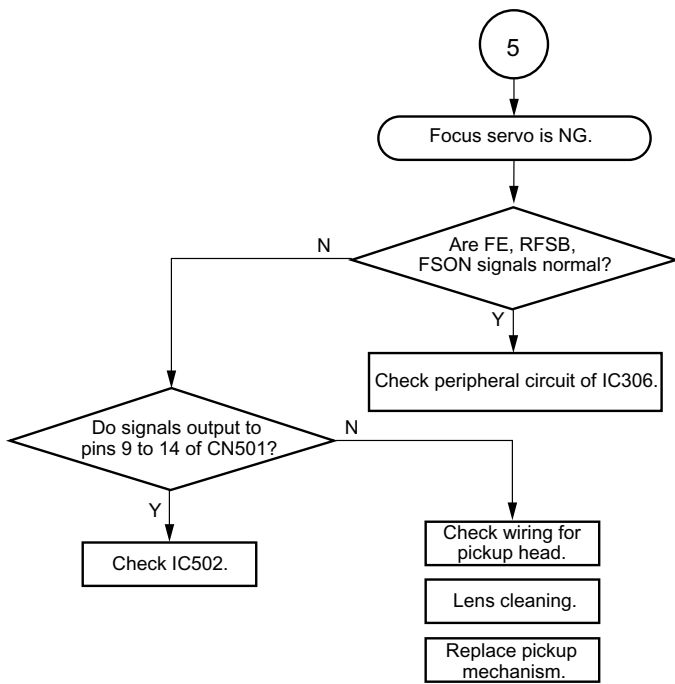

Fig. 1-3-11

Focus servo ON signal waveform

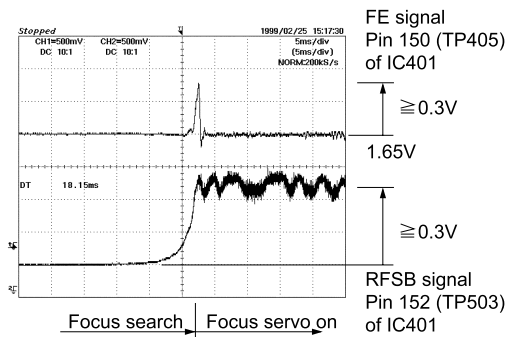

Fig. 1-3-12

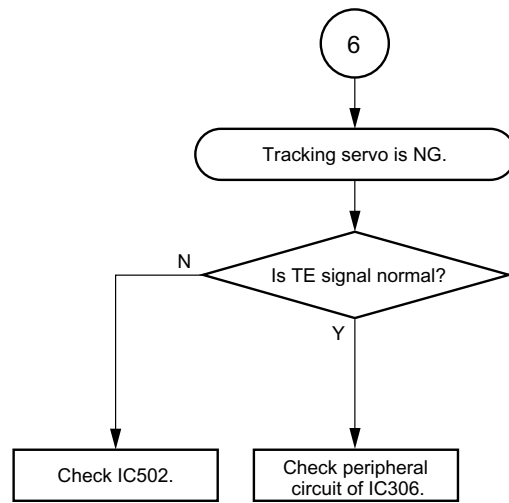
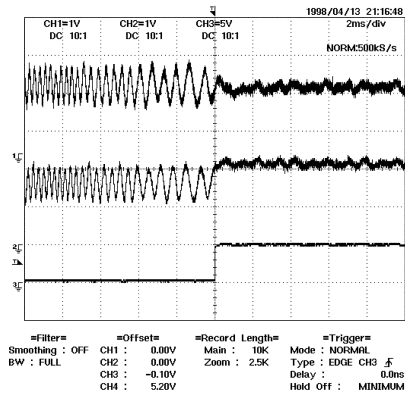

Fig. 1-3-13

Signal waveform at tracking servo ON (CD)



ON search | Tracking servo on

Fig. 1-3-14

Signal waveform at tracking servo ON (DVD)

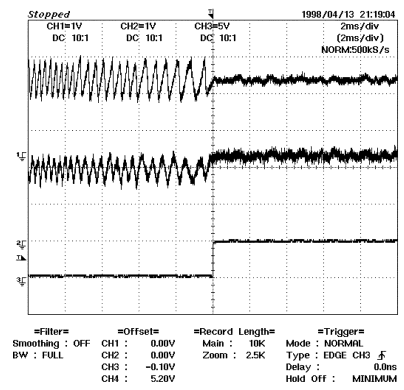

Fig. 1-3-15

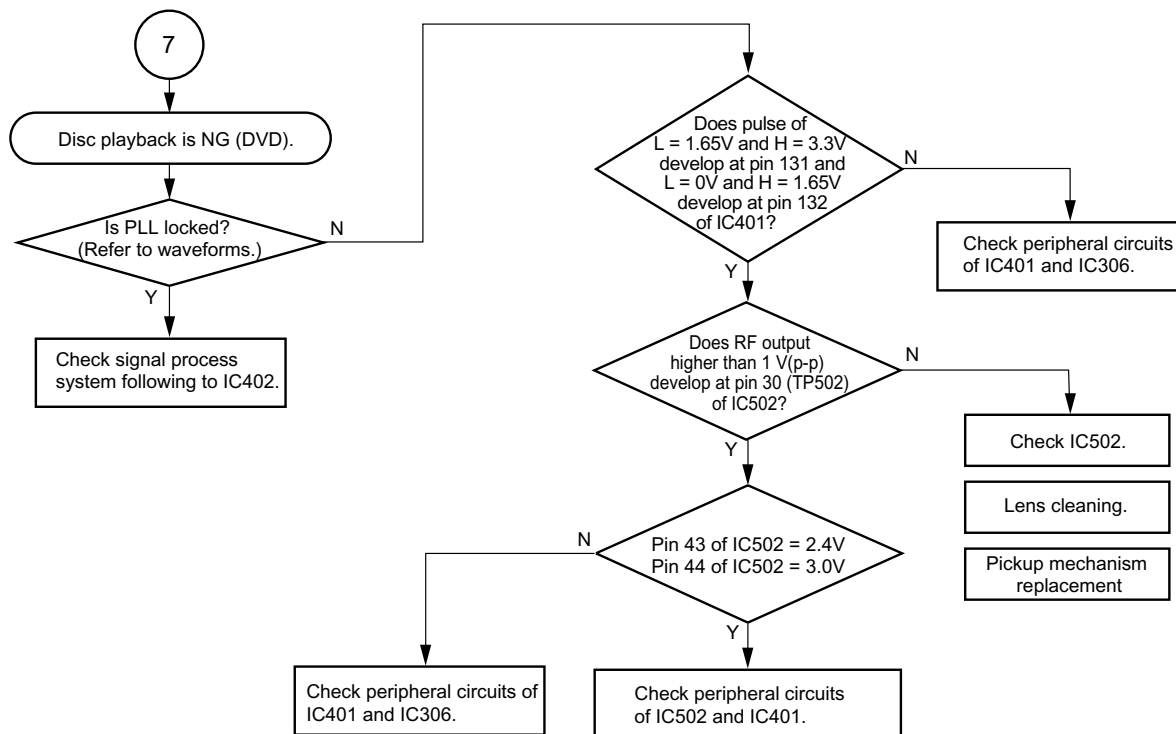

Fig. 1-3-16

PLL works as a servo loop to generate a clock signal for reading RF signal binary data. With the PLL locked, the eye pattern is identified clearly when triggered with the read clock PLCK.

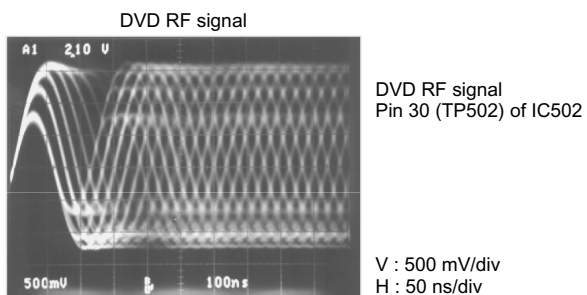

Fig. 1-3-17

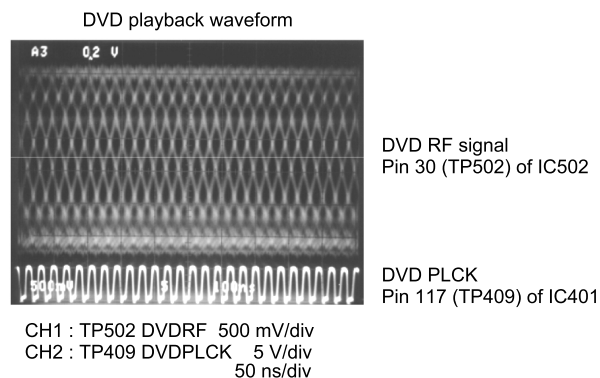

Fig. 1-3-19

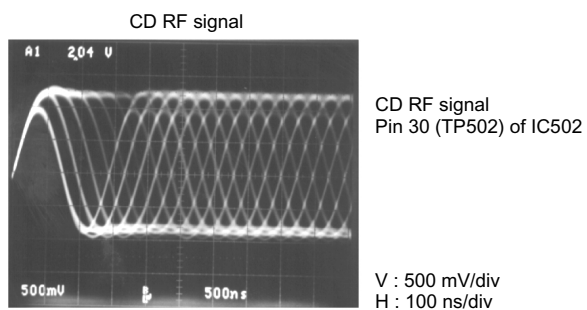

Fig. 1-3-18

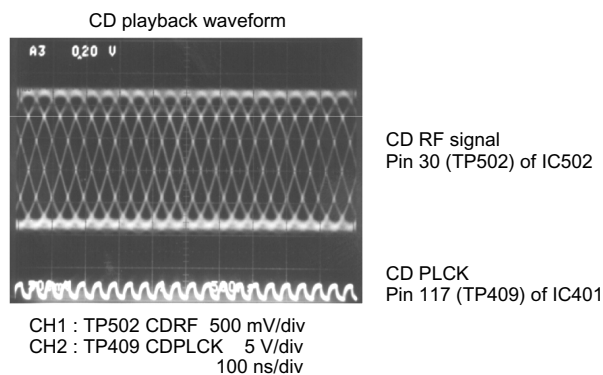

Fig. 1-3-20

3-1-2. Location Diagram of Servo Test Point

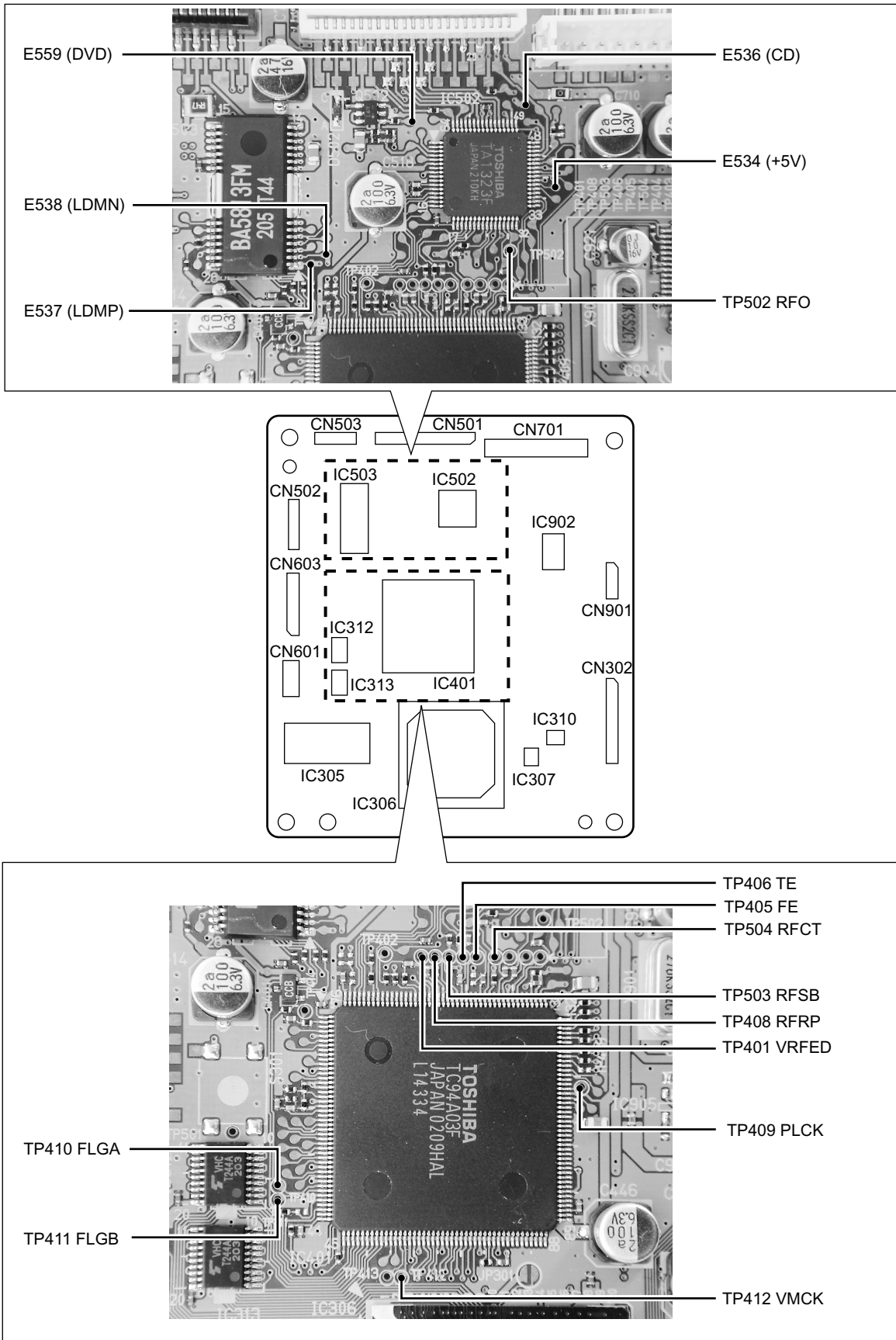

Fig. 1-3-21

SECTION 2

PART REPLACEMENT AND ADJUSTMENT PROCEDURES

CAUTIONS BEFORE STARTING SERVICING

Electronic parts are susceptible to static electricity and may easily be damaged, so do not forget to take a proper grounding treatment as required.

Many screws are used inside the unit. To prevent missing, dropping, etc. of the screws, always use a magnetized screwdriver in servicing. Several kinds of screws are used and some of them need special cautions. That is, take care of the tapping screws securing molded parts and fine pitch screws used to secure metal parts. If they are used improperly, the screw holes will be easily damaged and the parts can not be fixed.

1. REPLACEMENT OF MECHANICAL PARTS (TYPE A)

1-1. Cabinet Replacement

1-1-1. Top Cover

1. Remove seven screws (1), then remove the top cover (2).

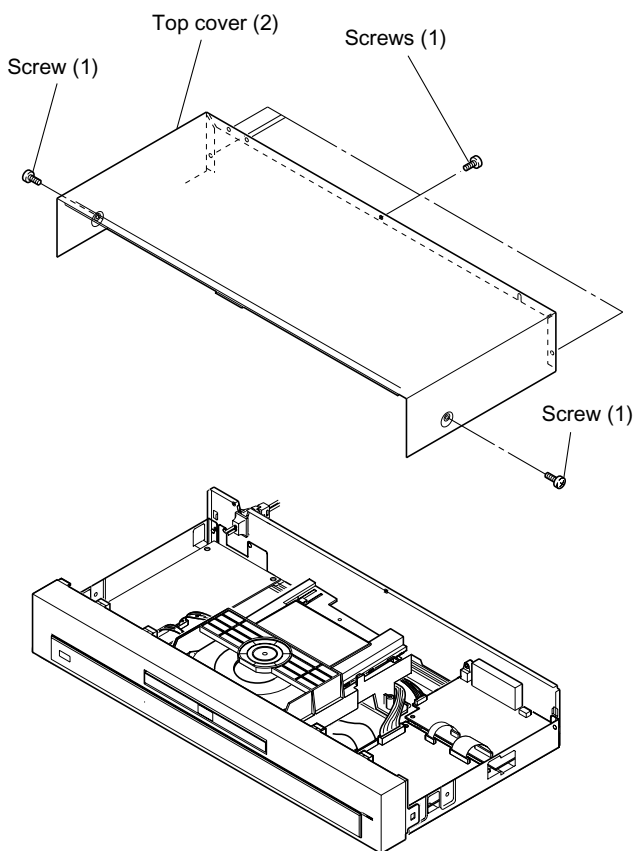

Fig. 2-1-1

1-1-2. Tray Panel

<Tray Ejection>

1. Insert a paper clip, etc. into the hole A to eject the tray (1).

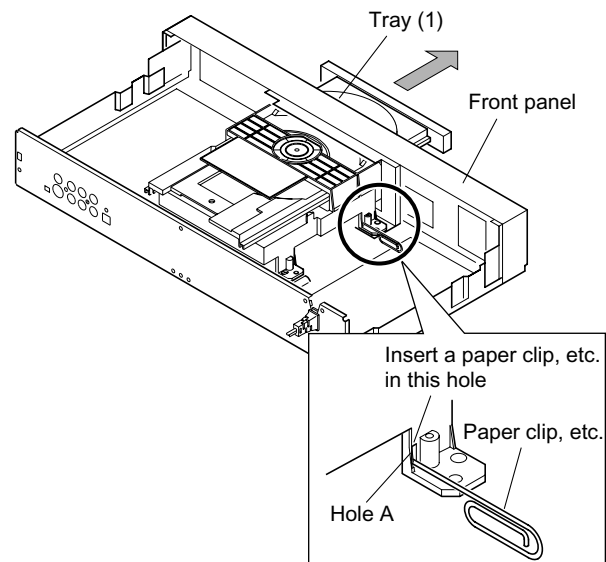

Fig. 2-1-2

<Tray Panel Removal>

1. Eject the tray (1). (Refer to item 1-1-2.)
2. Twist the tray panel (2) a little in the arrow A direction with the tray (1) hold by hand to release two claws and lift up the tray panel (2) in the arrow B direction, then the tray panel (2) is removed.
3. When mounting the tray panel (2), insert the tray panel (2) along the grooves of the both sides of the tray (1) until clicking.

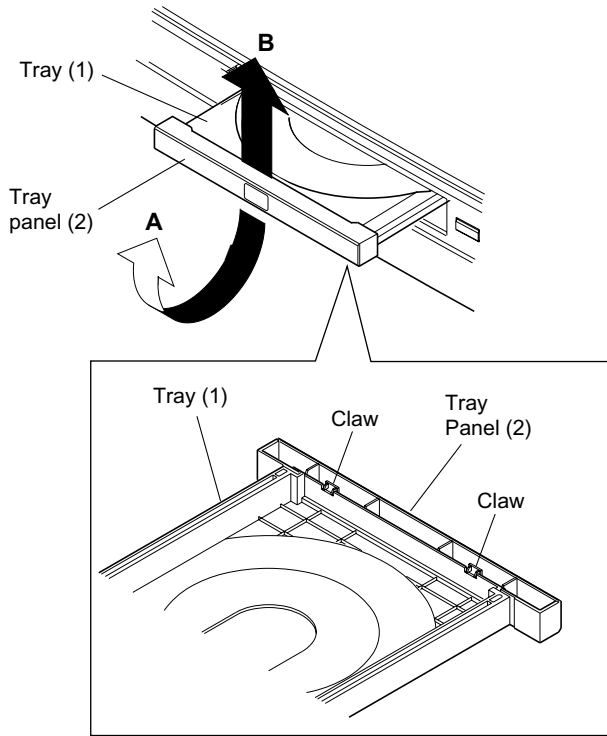

Fig. 2-1-3

1-1-3. Front Panel

1. Remove one flexible cable (1).
2. Release four claws, then remove the front panel (2).

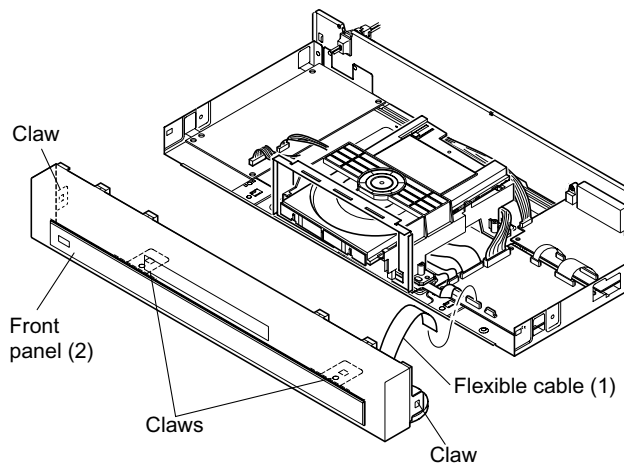

Fig. 2-1-4

1-1-4. Tray

1. Pull out the tray (1) towards you until it stops.
2. Lift up claw A with a minus screwdriver, and pull out the tray (1) towards you, then remove the tray (1).

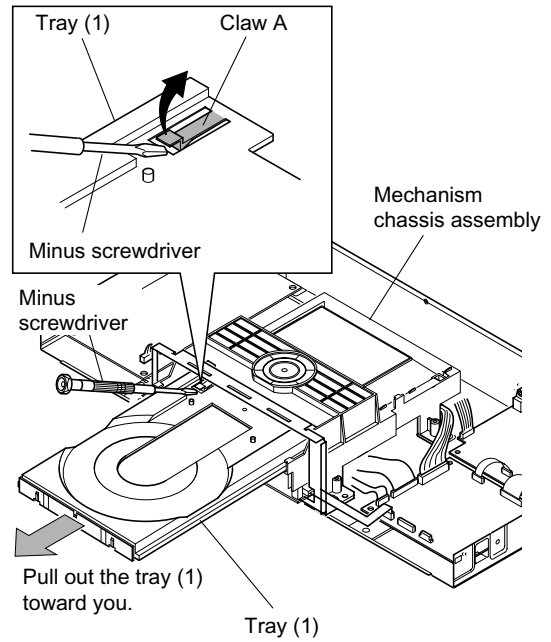

Fig. 2-1-5

1-1-5. Rear Panel

1. Remove the bush (1).
2. Remove four screws (2), then remove the rear panel (3).

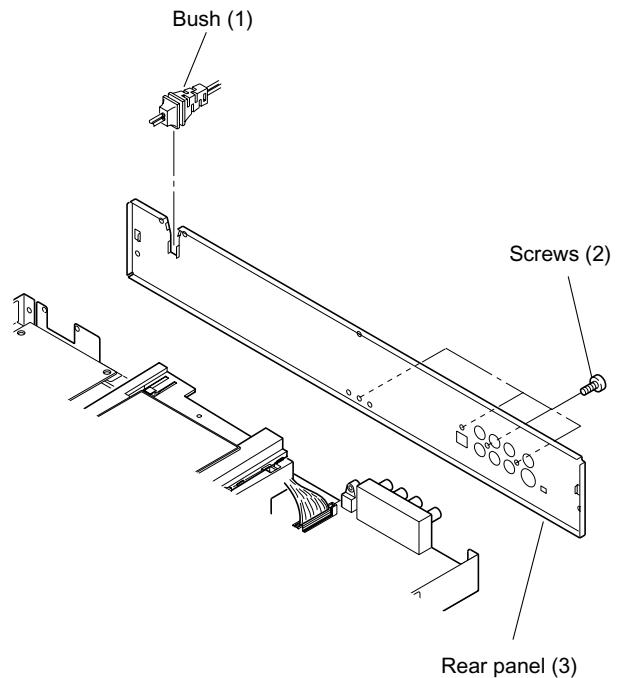

Fig. 2-1-6

1-2. PC Board Replacement

1-2-1. Main PC Board

Note:

- Before removing the main PC board (4), be sure to short-circuit the laser diode output land.
- After replacing, open the land as it was after inserting the flexible cables (1).

1. Remove the top cover. (Refer to item 1-1-1.)
2. Eject the tray. (Refer to item 1-1-2.)
3. Remove six flexible cables (1) and remove one connector (2).
4. Remove four screws (3), then remove the main PC board (4).

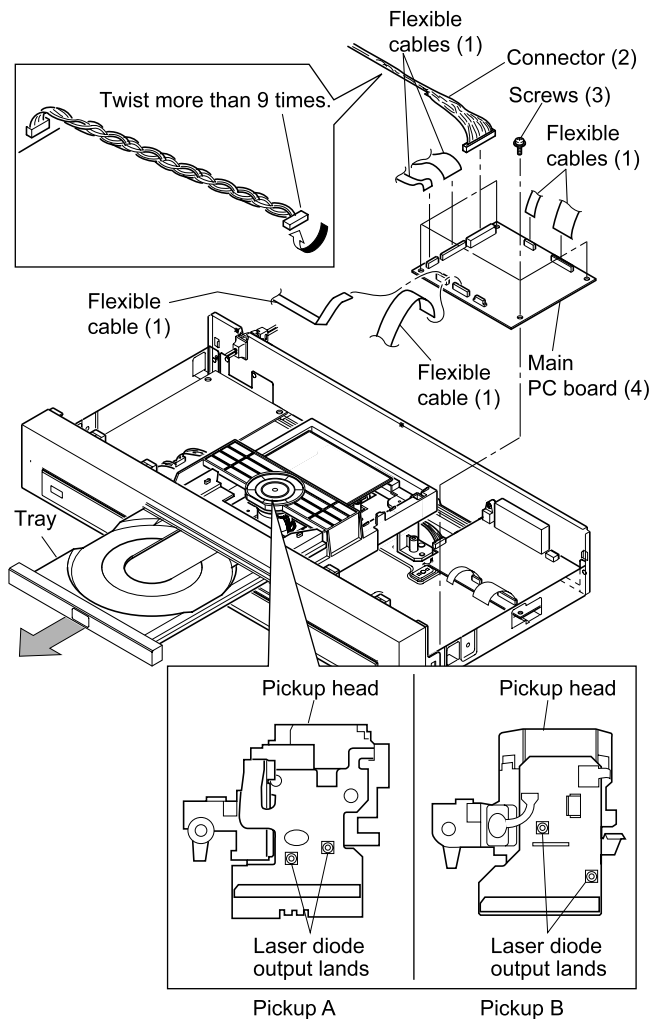

Fig. 2-1-7

1-2-2. Output PC Board

1. Remove the top cover. (Refer to item 1-1-1.)
2. Peel off two tapes (1) and remove the connector (2).
3. Remove two flexible cables (3).
4. Remove five screws (4), then remove the output PC board (5).

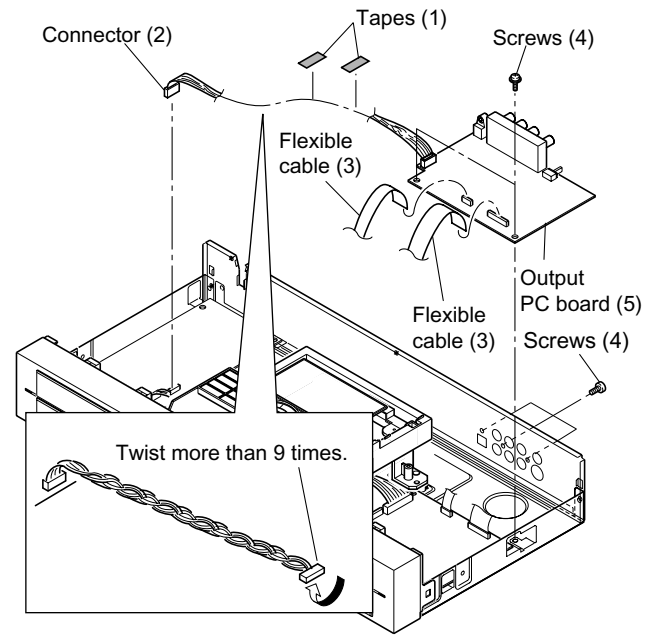

Fig. 2-1-8

1-2-3. Power PC board

1. Remove the bush (1).
2. Peel off two tapes (2) and remove two connectors (3).
3. Remove four screws (4), then remove the power supply PC board (5).

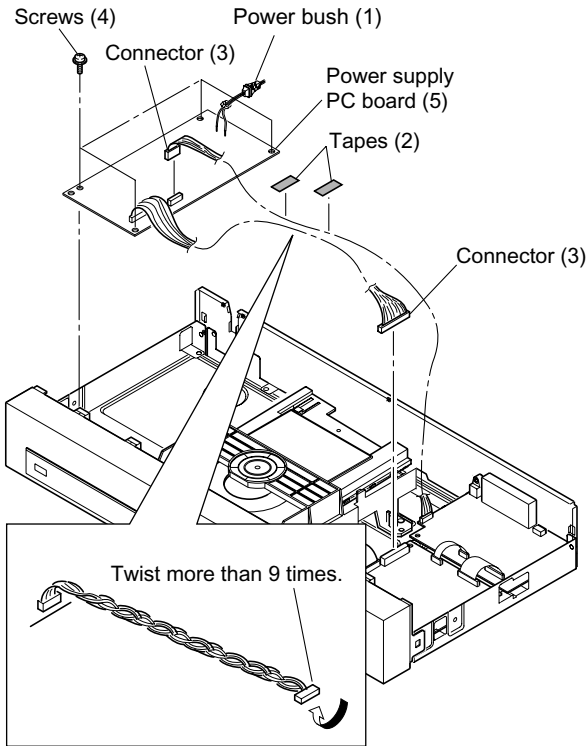

Fig. 2-1-9

1-2-4. Front PC Board

1. Remove the front panel. (Refer to item 1-1-3.)
2. Remove the flexible cable (1).
3. Remove nine screws (2), then remove the front display PC board (3).
4. Remove two screws (4), then remove the power switch PC board (5).
5. Remove three screws (6), then remove the ENTER switch (7).

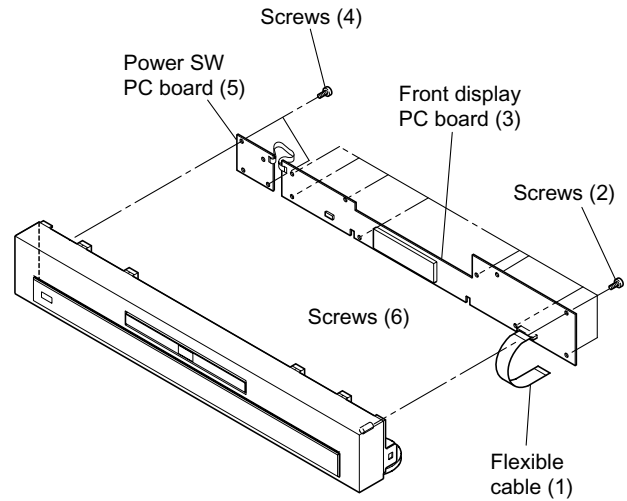

Fig. 2-1-10

1-3. Mechanism Parts

1-3-1. Mechanism Chassis Assembly

Note:

- When removing the mechanism chassis assembly (3), be sure to short-circuit the laser diode output land before removing the connector and the flexible cables.

After replacing, open the land as it was after inserting the connector and flexible cables.

1. Remove the front panel. (Refer to item 1-1-3.)
2. Remove three flexible cables (1).
3. Remove four screws (2), then remove the mechanism chassis assembly (3).

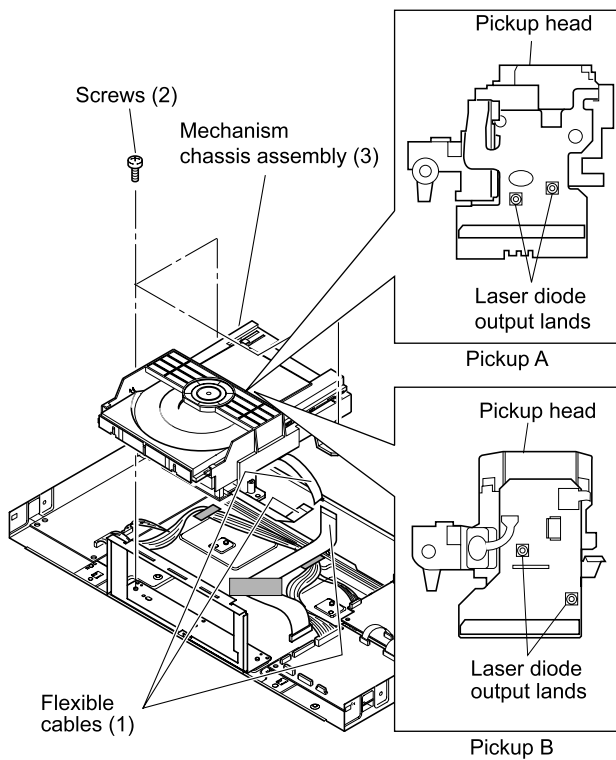

Fig. 2-1-11

2. REPLACEMENT OF MECHANICAL PARTS (TYPE B)

2-1. Cabinet Replacement

2-1-1. Top Cover

1. Remove seven screws (1), then remove the top cover (2).

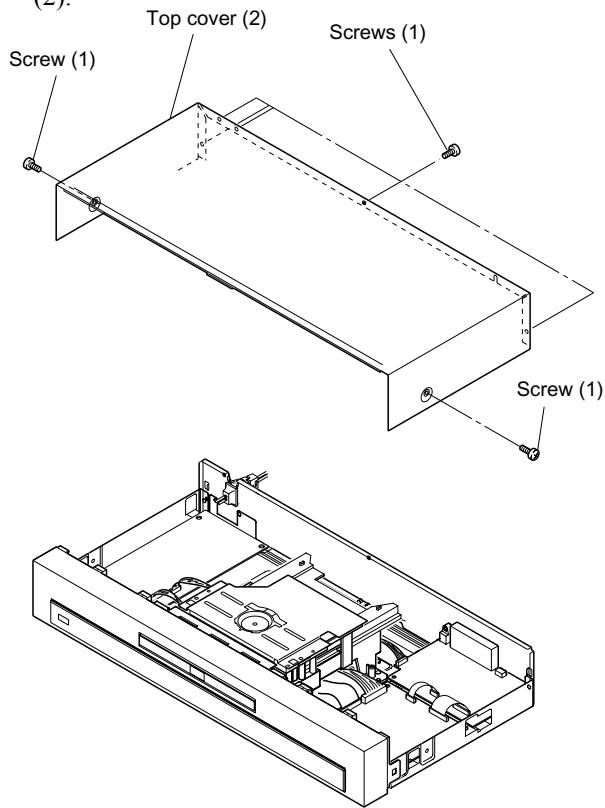

Fig. 2-1-12

2-1-2. Clamper Stay

<Removal>

1. Remove two screws (1).
2. Release two claws and remove the clamper stay (2).

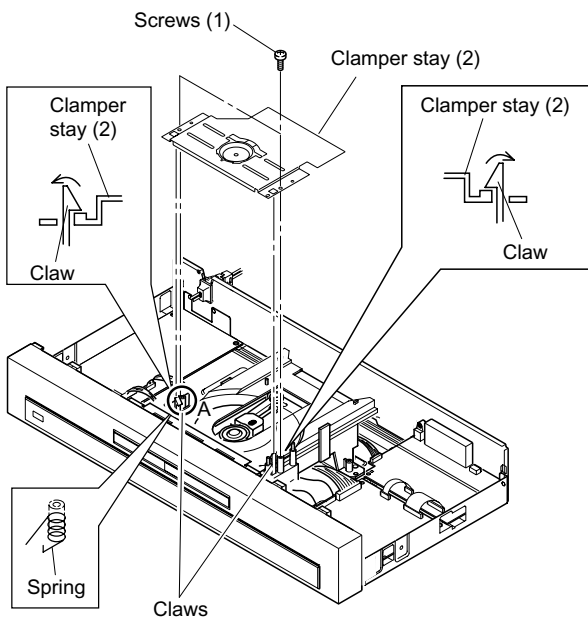

Fig. 2-1-13

<Mounting>

1. The spring for tray side pressure is inserted into the portion "A". (Refer to Fig. 2-1-13.)
2. By referring to Fig. 2-1-14, insert the spring normally and mount the clamper stay.

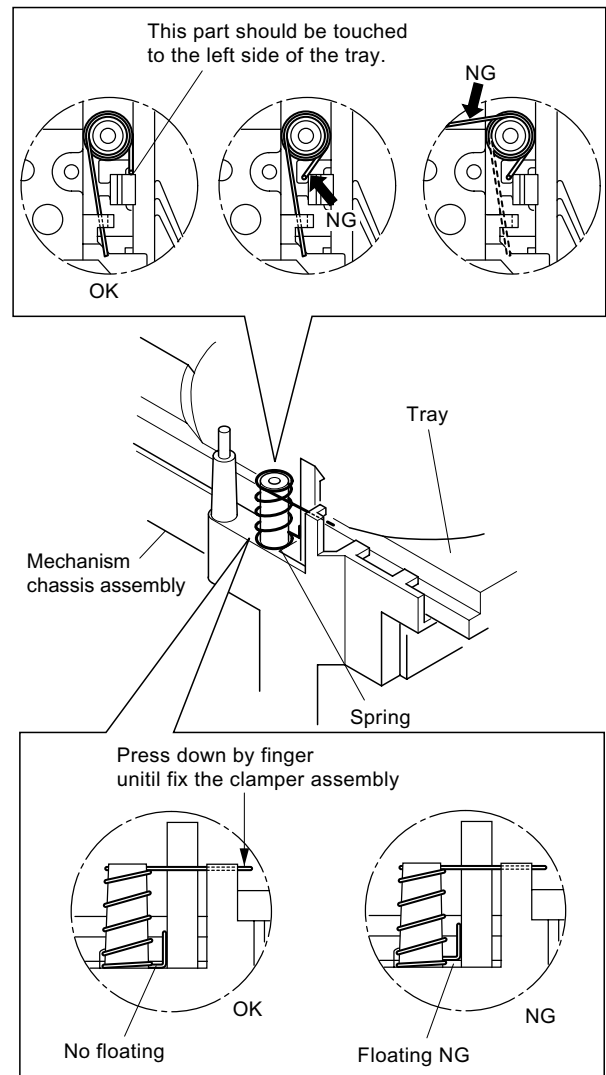

Fig. 2-1-14

2-1-3. Tray Panel

<Tray Ejection>

1. Slide the slider (2) of the mechanism chassis assembly (1) with a screwdriver, etc. in the arrow direction, so that the tray (3) is ejected.

Note:

- Take care not to damage the pickup and other parts.

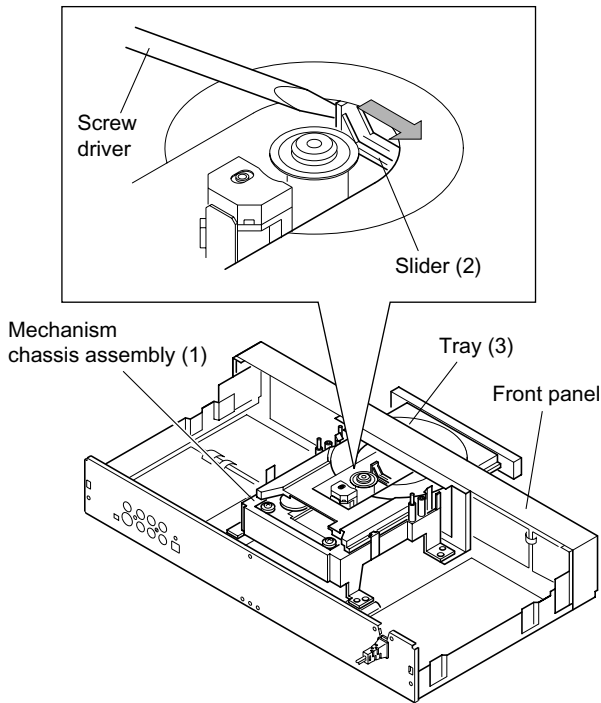

Fig. 2-1-15

<Tray Panel Removal>

1. Eject the tray (3).
2. Twist the tray panel (4) a little in the arrow A direction with the tray (3) hold by hand to release two claws and lift up the tray panel (4) in the arrow B direction, then the tray panel (4) is removed. (Refer to Fig. 2-1-16.)
3. When mounting the tray panel (4), insert the tray panel (4) along the grooves of the both sides of the tray (3) until clicking.

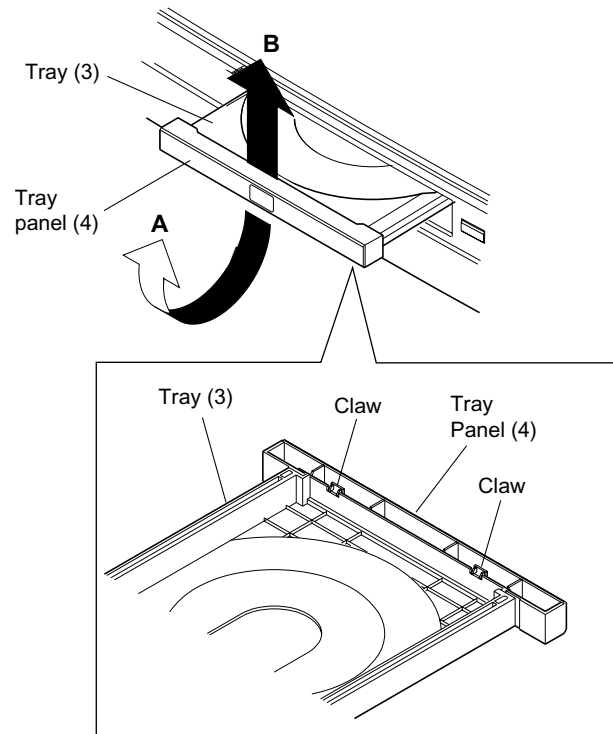

Fig. 2-1-16

2-1-4. Front Panel and Tray

1. Remove the flexible cable (1).
2. Release four claws and remove the front panel (2).
3. Pull out the tray (3) towards you.

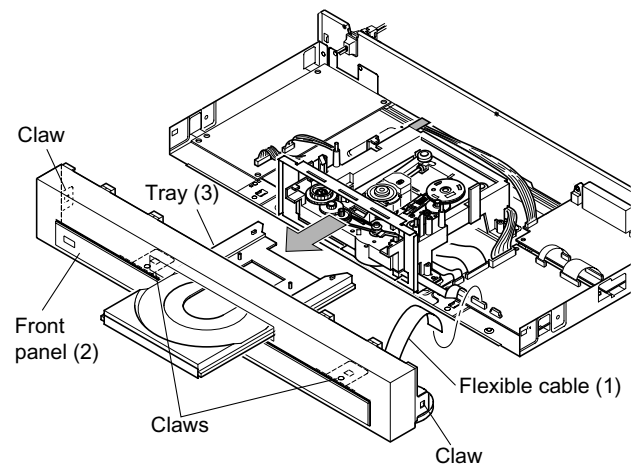

Fig. 2-1-17

Note:

- Insert the tray (3) with the front side of the pickup mechanism assembly descended. (The slider positions to the left side.)
- The gears are required to match their phases each other. After setting the gear (4) as shown in the figure "A", insert the tray (3). When inserting a tray (3), push the rack gear side shown by the arrow.

- Confirm that the mark of the gear matches with the triangle mark on the reverse side of the tray in the tray close status. (The gear is rotated with the slider locks.) (Refer to Fig. B.)

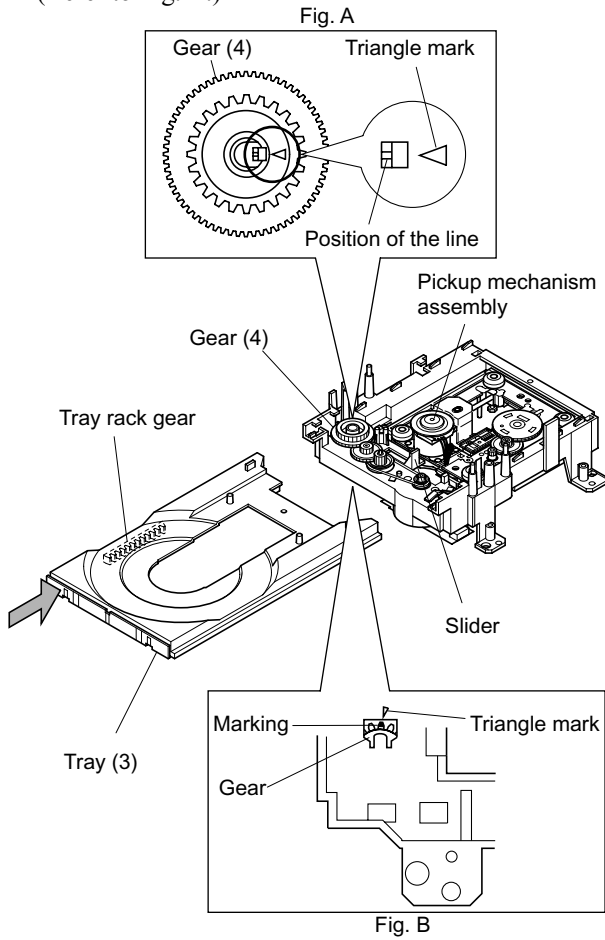

Fig. 2-1-18

2-1-5. Rear Panel

1. Remove the bush (1).
2. Remove four screws (2), then remove the rear panel (3).

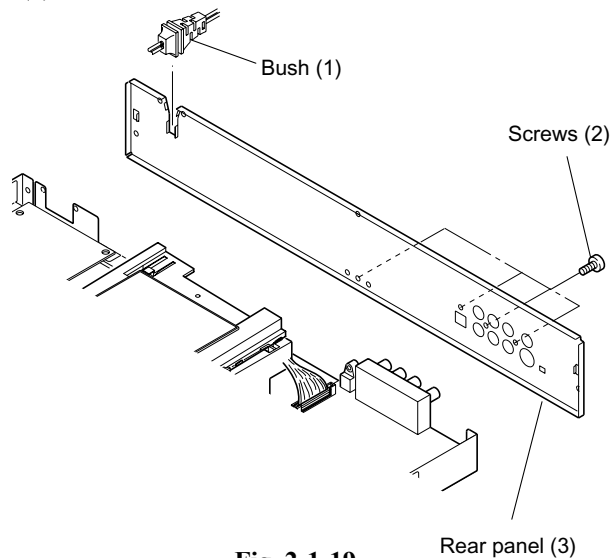

Fig. 2-1-19

2-2. PC Board Replacement

2-2-1. Main PC Board

Note:

- Before removing the main PC board (4), be sure to short-circuit the laser diode output land.
- After replacing, open the land as it was after inserting the flexible cables (1).
1. Remove the top cover. (Refer to item 2-1-1.)
 2. Eject the tray. (Refer to item 2-1-3.)
 3. Remove six flexible cables (1) and remove one connector (2).
 4. Remove four screws (3), then remove the main PC board (4).

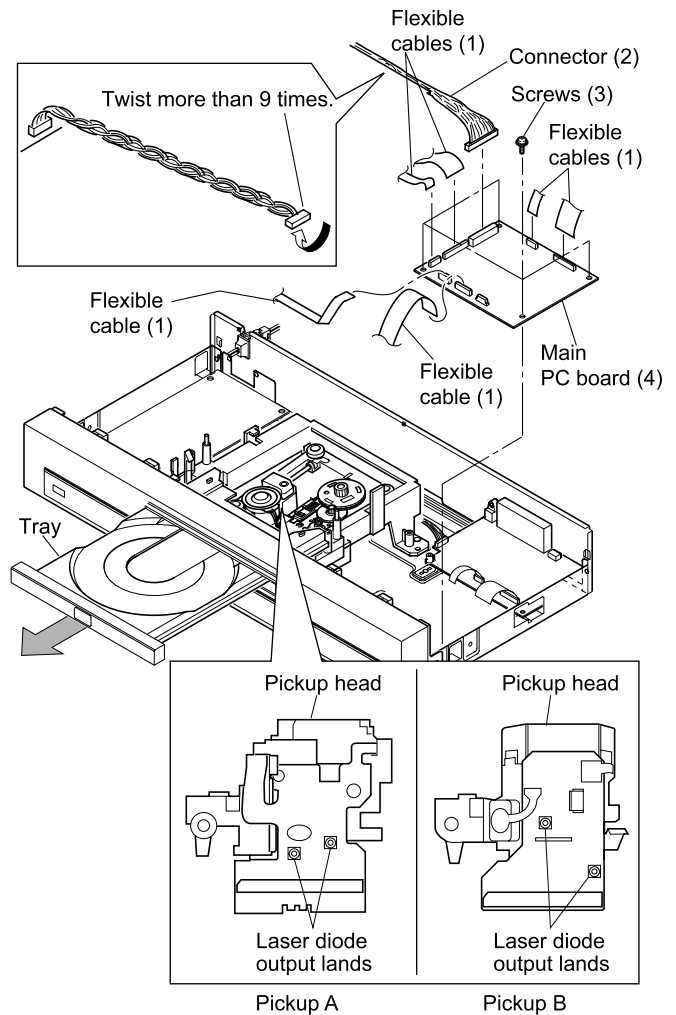

Fig. 2-1-20

2-2-2. Output PC Board

1. Remove the top cover. (Refer to item 2-1-1.)
2. Peel off two tapes (1) and remove the connector (2).
3. Remove two flexible cables (3).
4. Remove five screws (4), then remove the output PC board (5).

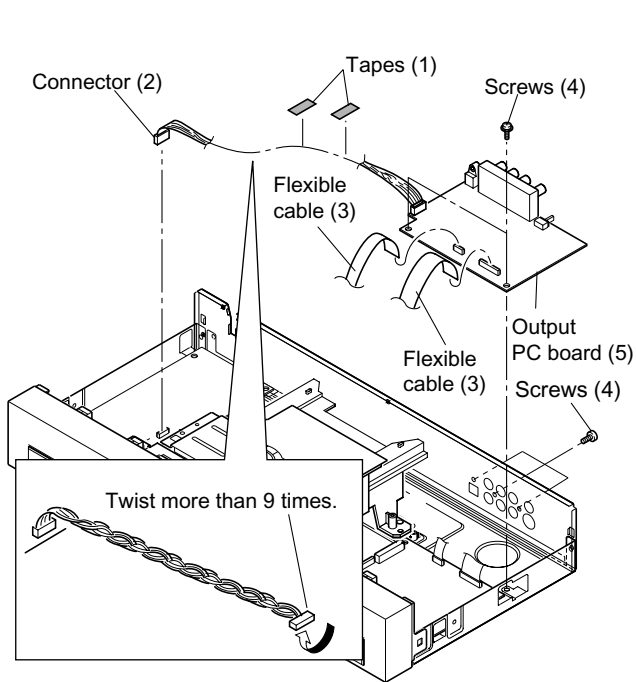

Fig. 2-1-21

2-2-3. Power PC board

1. Remove the power bush (1).
2. Peel off two tapes (2) and remove two connectors (3).
3. Remove four screws (4), then remove the power supply PC board (5).

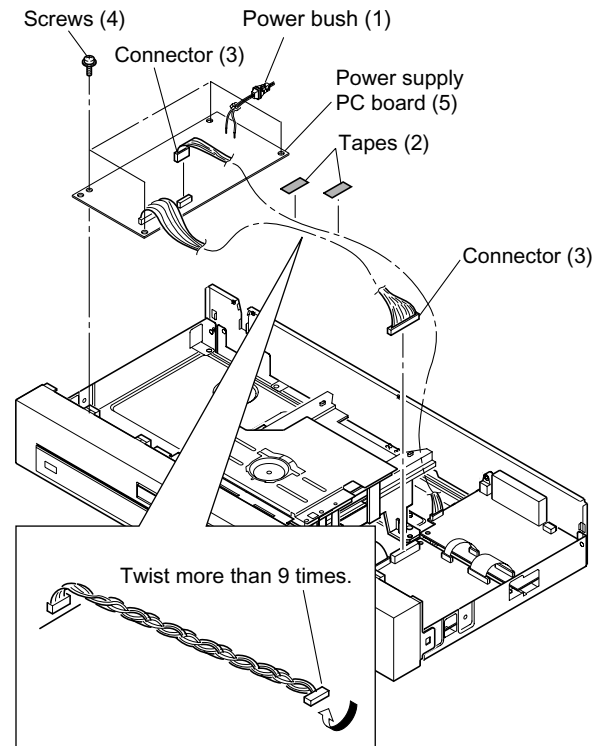

Fig. 2-1-22

2-2-4. Front PC Board

1. Remove the front panel. (Refer to item 2-1-4.)
2. Remove the flexible cable (1).
3. Remove six screws (2), then remove the front display PC board (3).
4. Remove two screws (4), then remove the power switch PC board (5).
5. Remove three screws (6), then remove the ENTER switch (7).

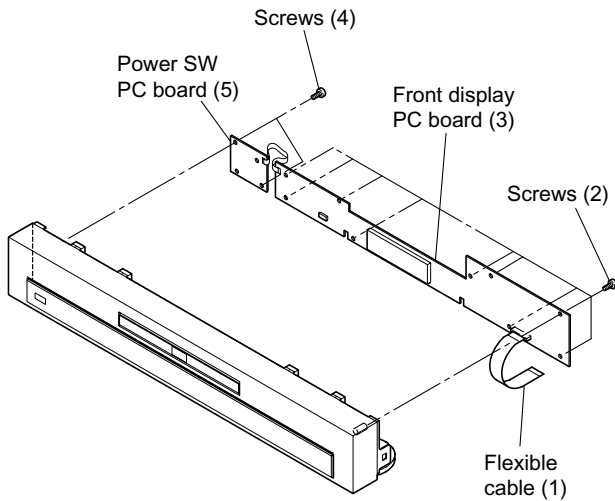

Fig. 2-1-23

2-3. Mechanism Parts

2-3-1. Mechanism Chassis Assembly

Note:

- When removing the mechanism chassis assembly (3), be sure to short-circuit the laser diode output land before removing the connector and the flexible cables.

After replacing, open the land as it was after inserting the connector and flexible cables.

1. Remove the tray. (Refer to items 2-1-3 and 2-1-4.)
2. Remove three flexible cables (1).
3. Remove four screws (2), then remove the mechanism chassis assembly (3).

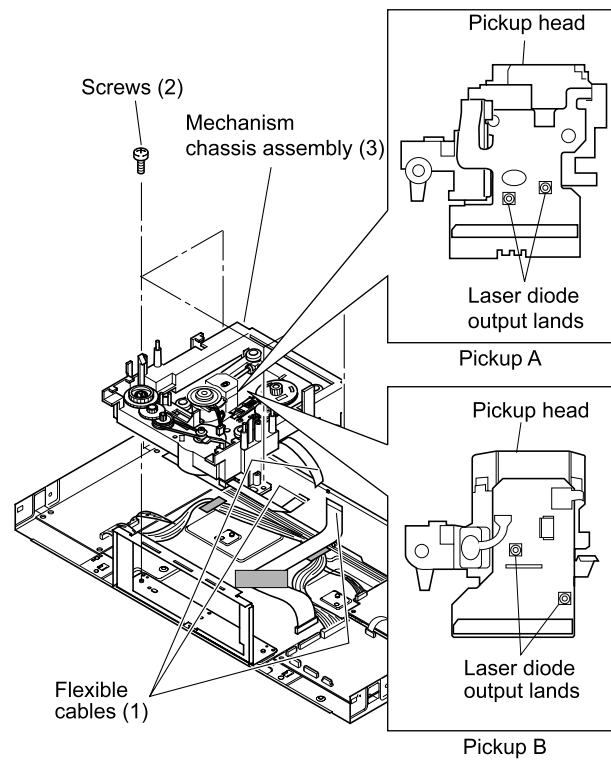

Fig. 2-1-24

SECTION 3

SERVICING DIAGRAMS

1. STANDING PC BOARDS FOR SERVICING

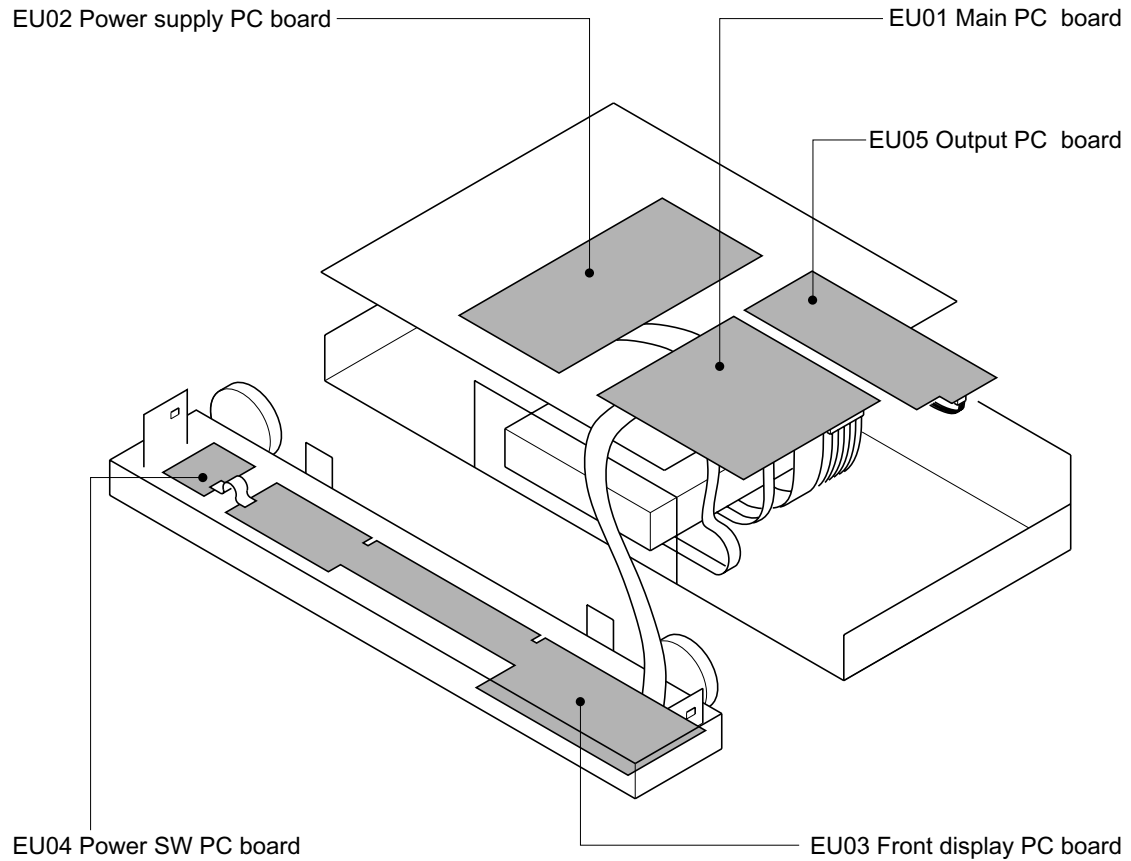

Fig. 3-1-1

2-4. Inductor Indication

Unit	None H μ μH m mH
Tolerance	None ±5% B ±0.1% C ±0.25% D ±0.5% F ±1% G ±2% K ±10% M ±20%

Eg. 4

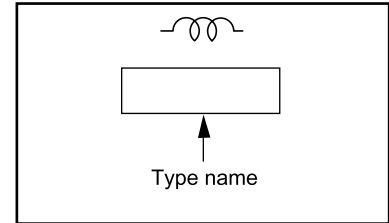

Fig. 3-2-4

2-5. Waveform and Voltage Measurement

- The waveforms for CD/DVD and RF shown in the circuit diagrams are obtained when a test disc is played back.
- All voltage values except the waveforms are expressed in DC and measured by a digital voltmeter.

2-6. Others

- The parts indicated with "NC" or "KETU" etc. are not used in the circuits of this model.

Eg. 5

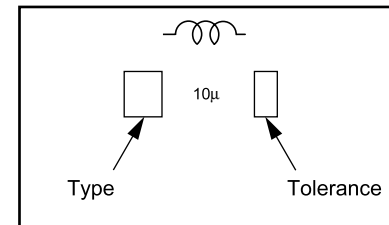

Fig. 3-2-5

3. (A) PRINTED WIRING BOARD AND SCHEMATIC DIAGRAM - DD-6030

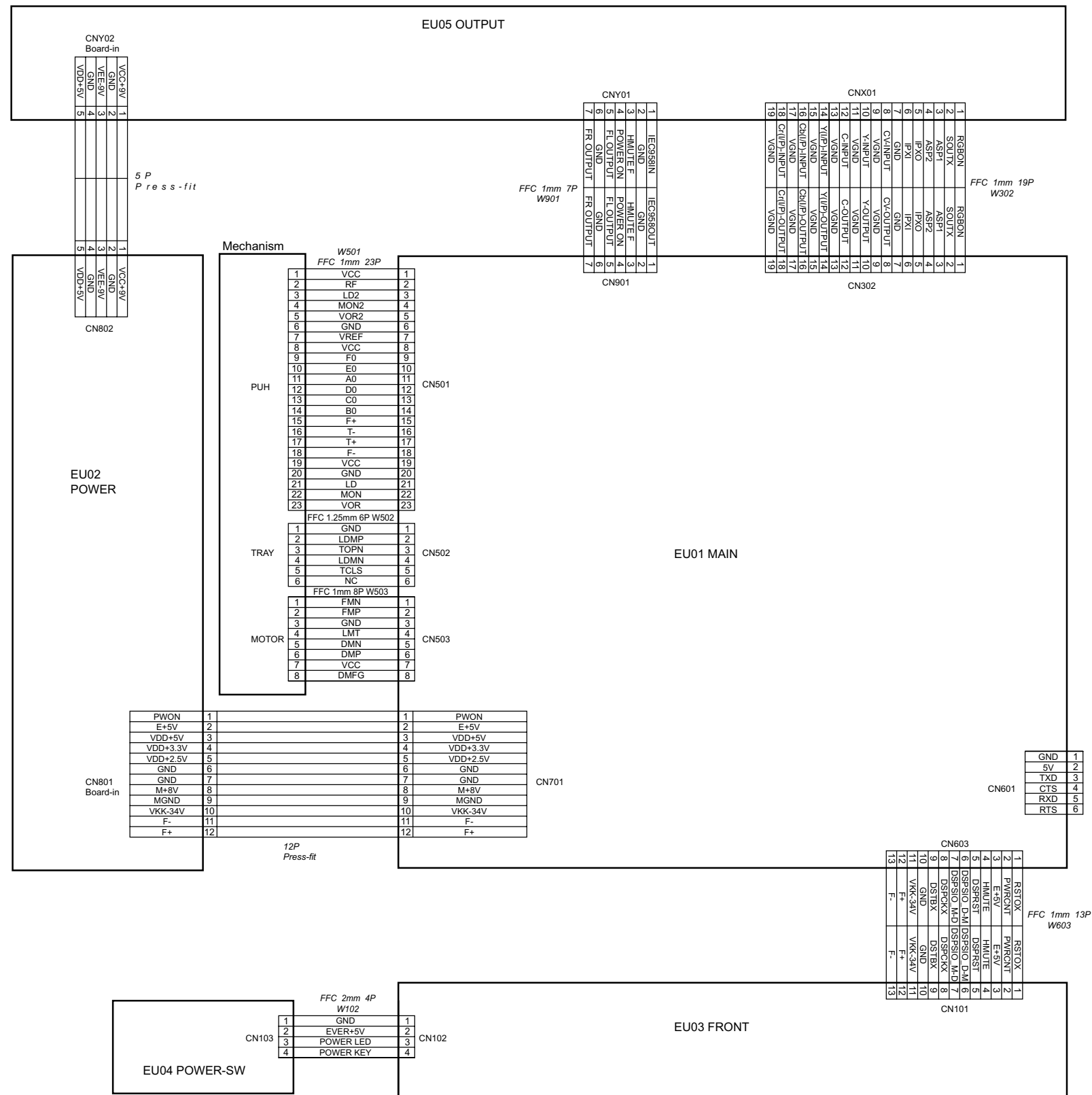

Fig. 3-3-1-A

3. (B) PRINTED WIRING BOARD AND SCHEMATIC DIAGRAM - DD-8030

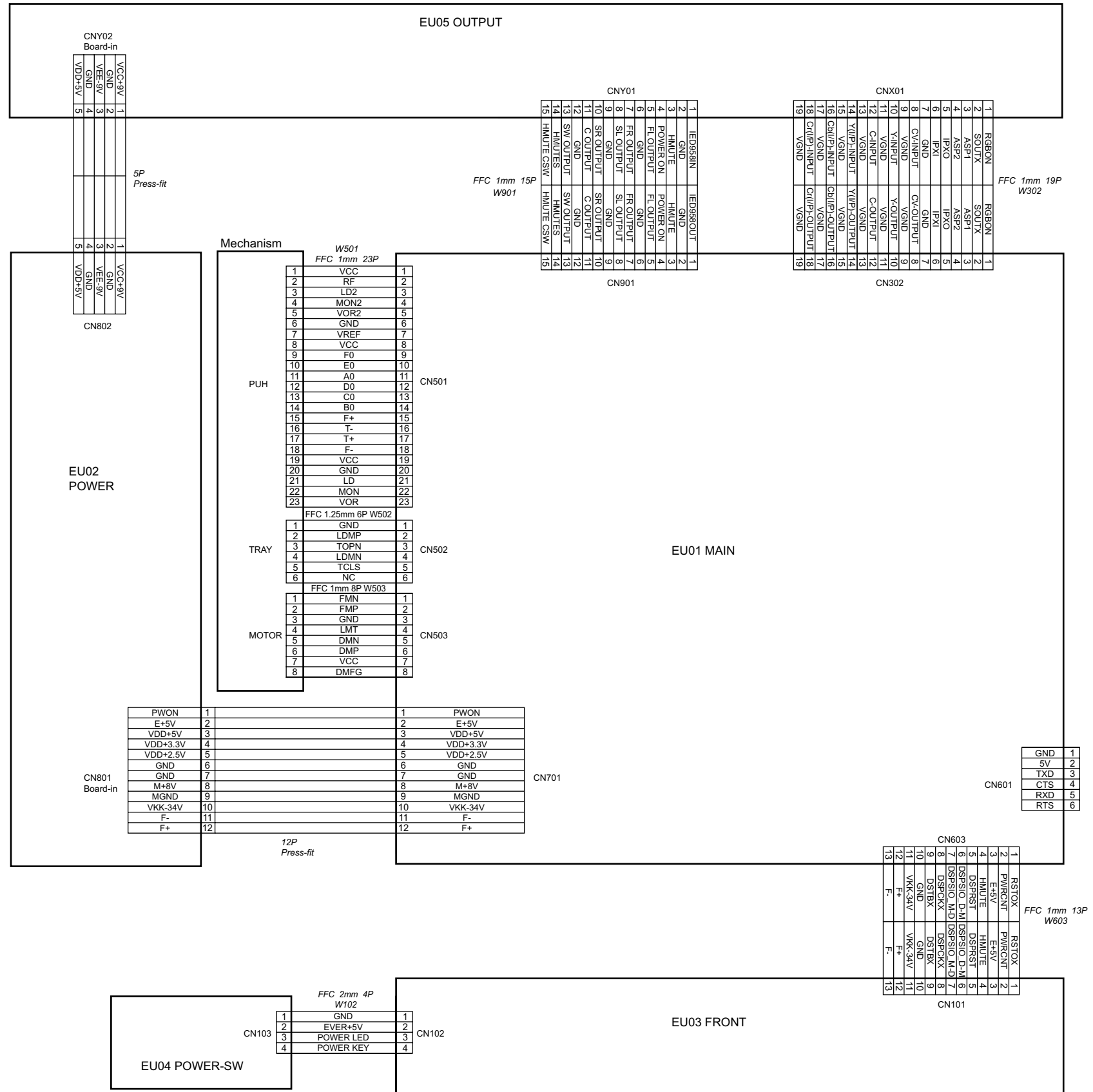

Fig. 3-1-1-B

4. BLOCK DIAGRAMS

4-1. (A) Overall Block Diagram - DD-6030

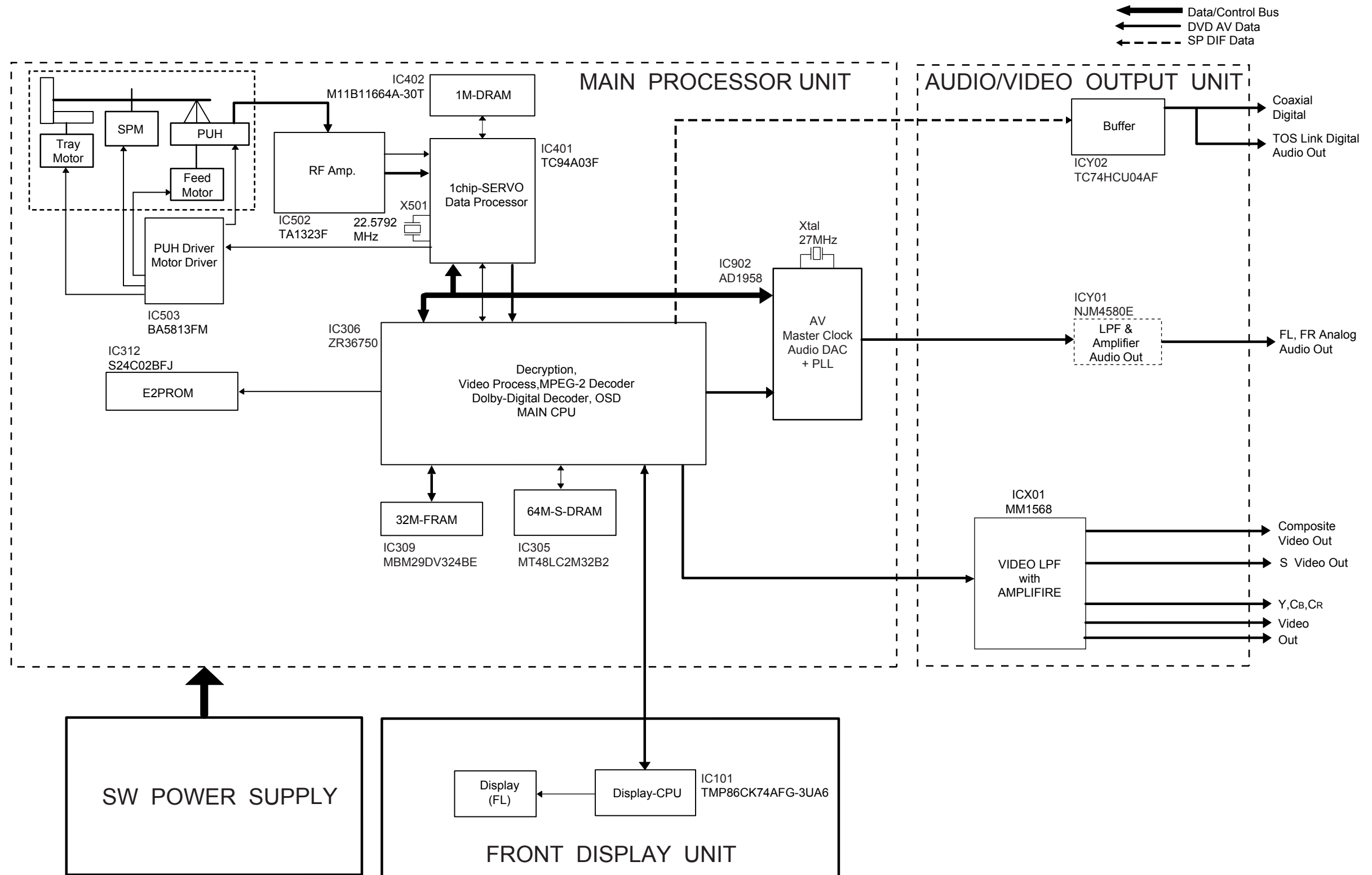

Fig.3-4-1-A

2-1. (B) Overall Block Diagram - DD-8030

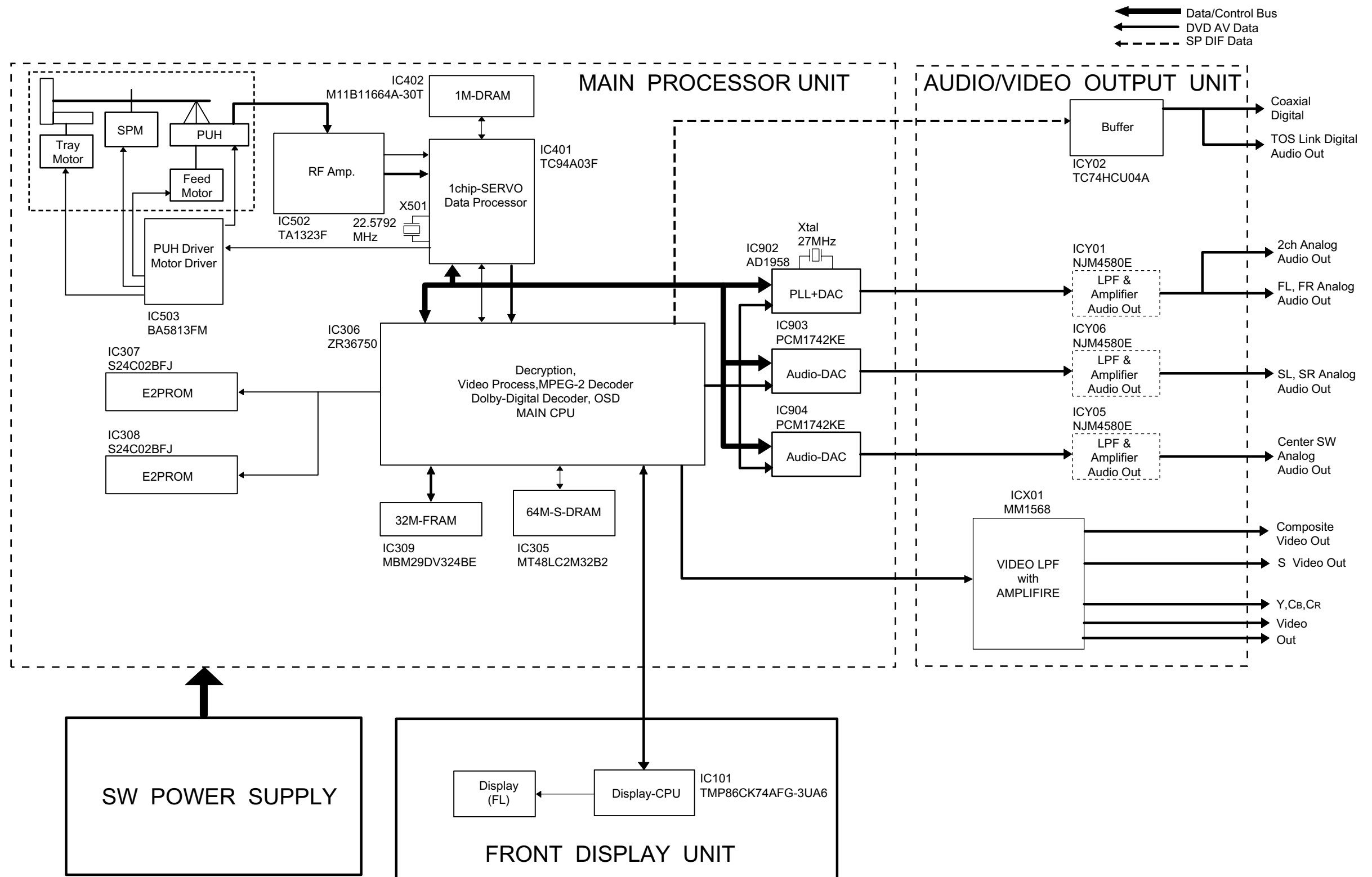

Fig.3-4-1-B

4-2. Power Supply Block Diagram

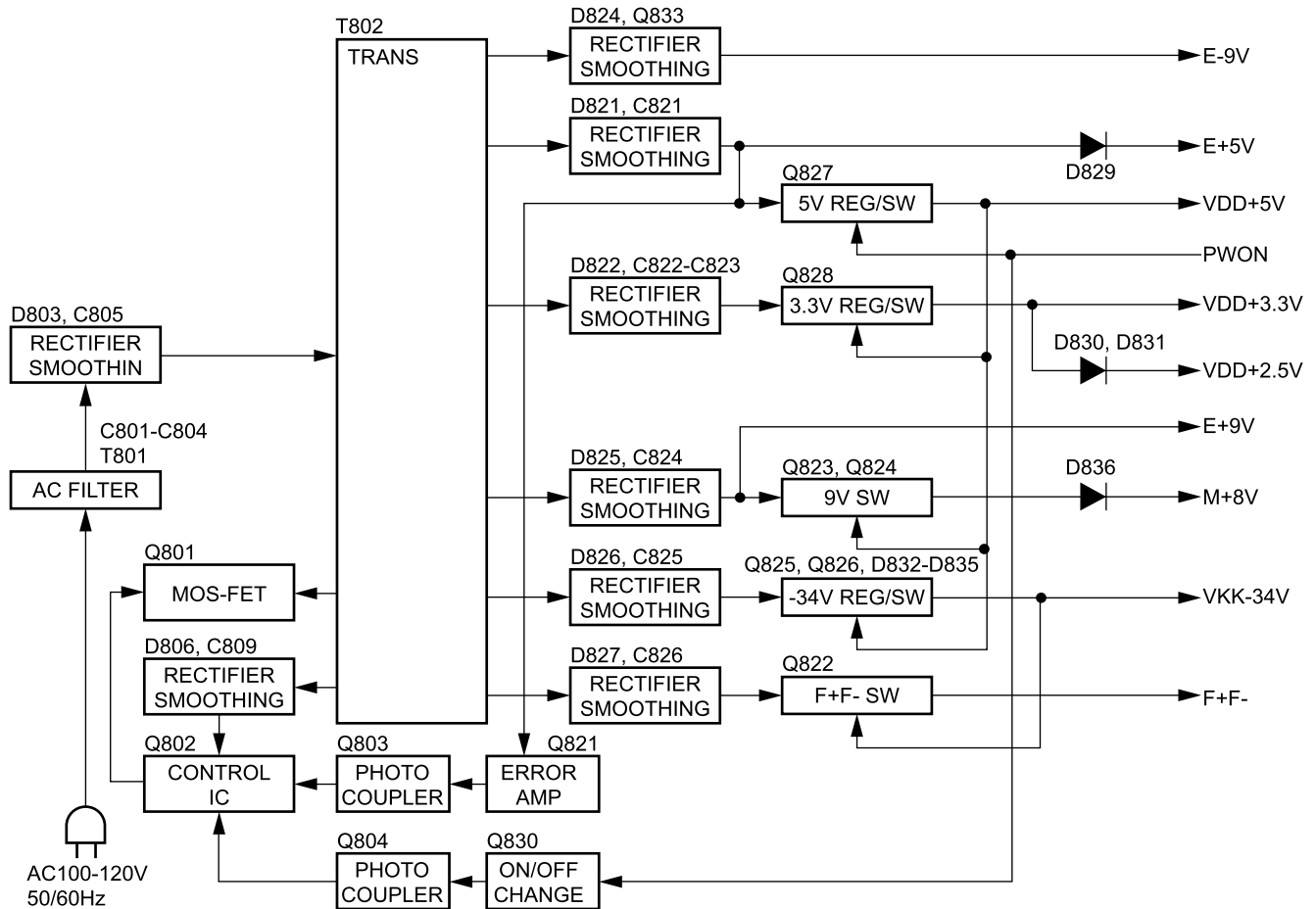

Fig. 3-4-2

4-3. Front Display, Power Switch Block Diagram

4-3-1. Front Display

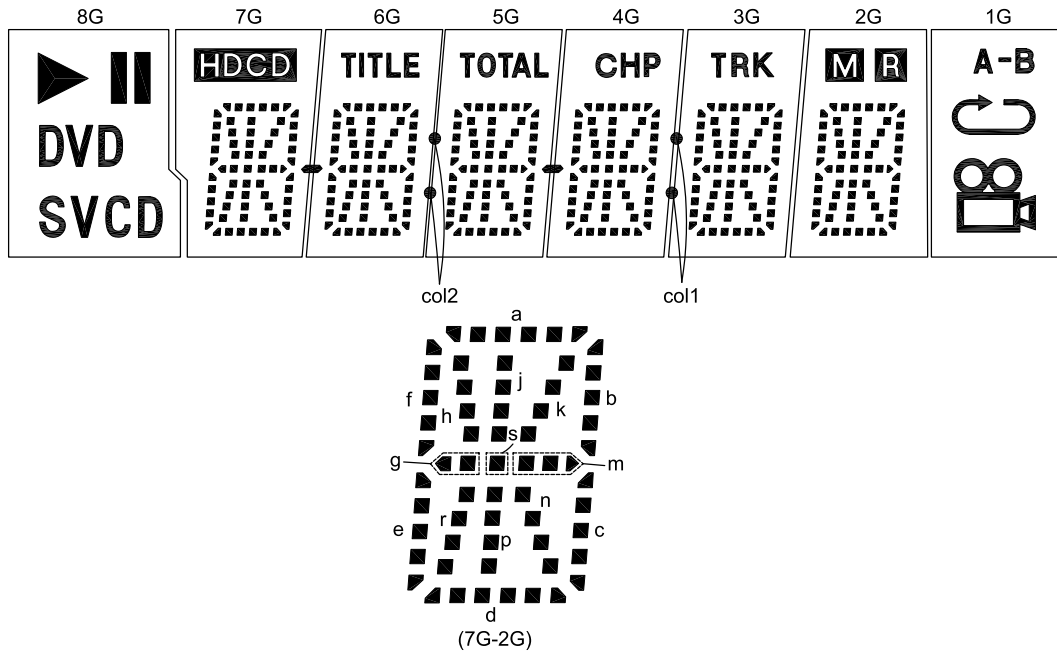

Fig. 3-4-3

4-3-2. Front Display Pattern

	8G	7G	6G	5G	4G	3G	2G	1G
P1	▶	a	a	a	a	a	a	A
P2	⏸	f	f	f	f	f	f	-B
P3	DVD	h	h	h	h	h	h	📷
P4	S	j	j	j	j	j	j	📷
P5	V	k	k	k	k	k	k	-
P6	CD	b	b	b	b	b	b	-
P7	-	g	g	g	g	g	g	-
P8	-	s	s	s	s	s	s	-
P9	-	m	m	m	m	m	m	-
P10	-	e	e	e	e	e	e	-
P11	-	r	r	r	r	r	r	-
P12	-	p	p	p	p	p	p	-
P13	-	n	n	n	n	n	n	-
P14	-	c	c	c	c	c	c	-
P15	-	d	d	d	d	d	d	-
P16	-	-	col2		col1		M	-
P17	-	▶		▶		-	R	-
P18	-	HD CD	TITLE	TOTAL	CHP	TRK	-	-

Fig. 3-4-4

4-3-3. Front Display , Power Switch Block Diagram

A101
HUV-08SS38T
8-BT-230GNK

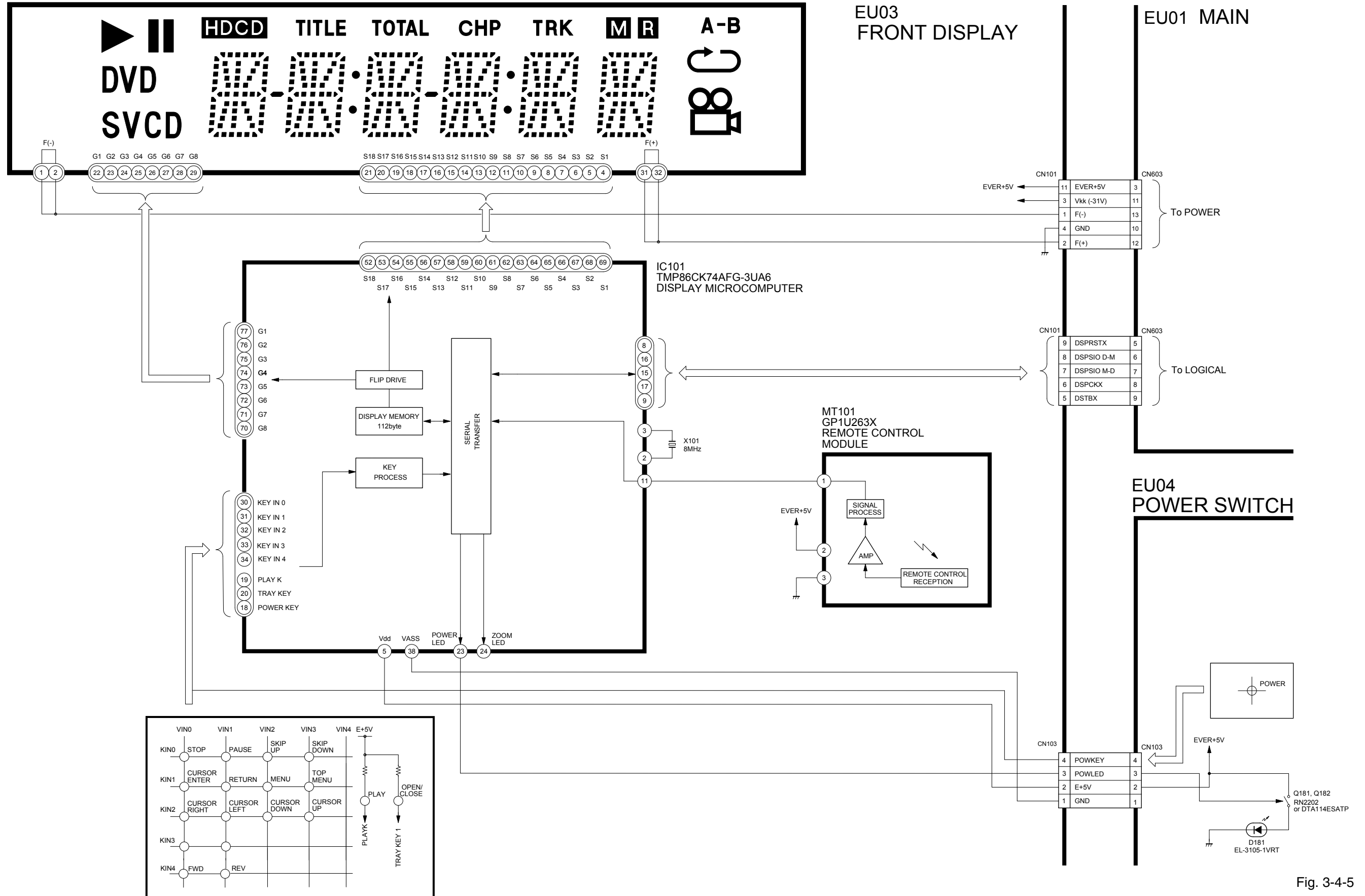

Fig. 3-4-5

4-4. Main Block Diagrams

4-4-1. Servo System Block Diagram

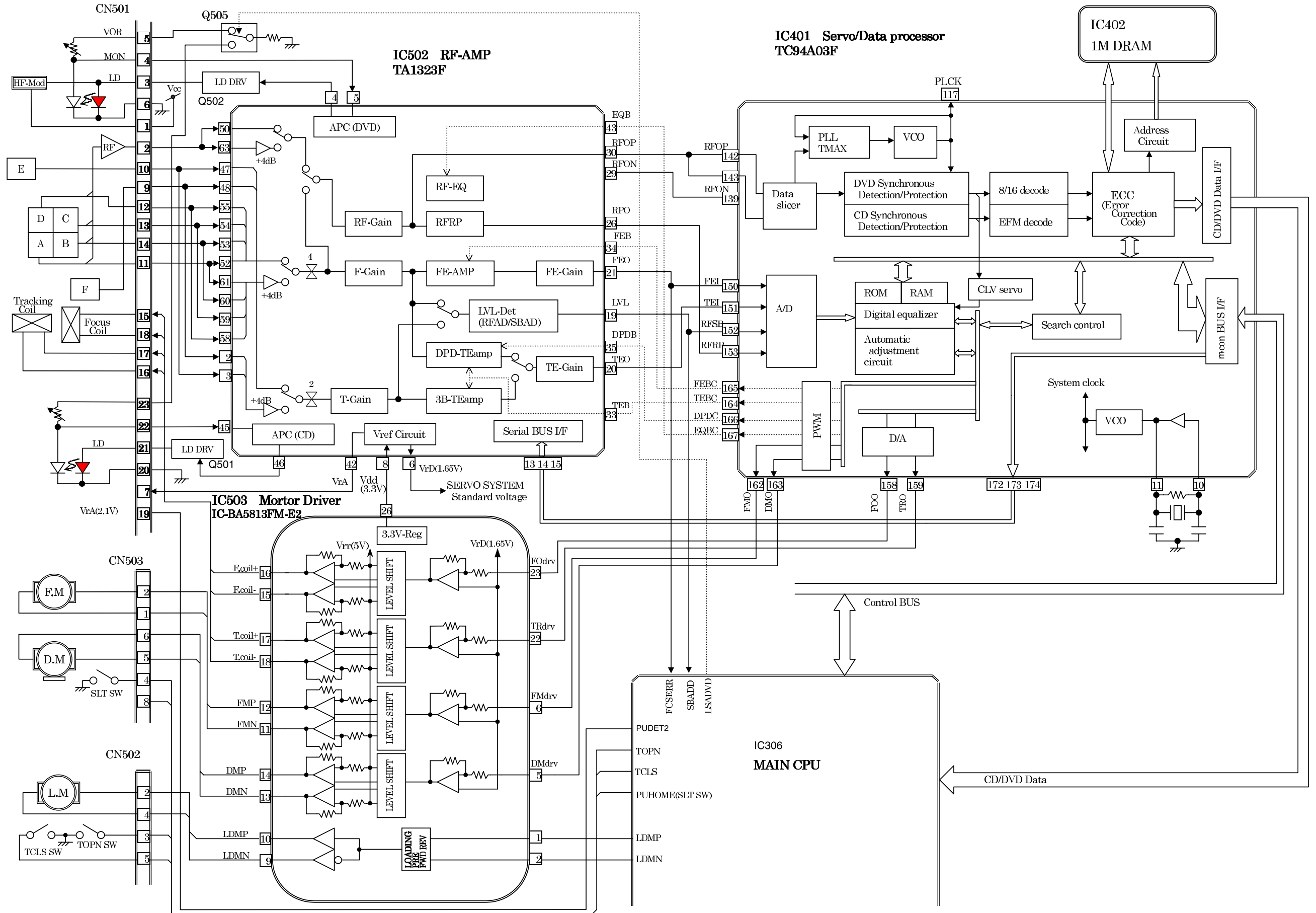

Fig.3-4-6

4-4-2. Logical System Block Diagram

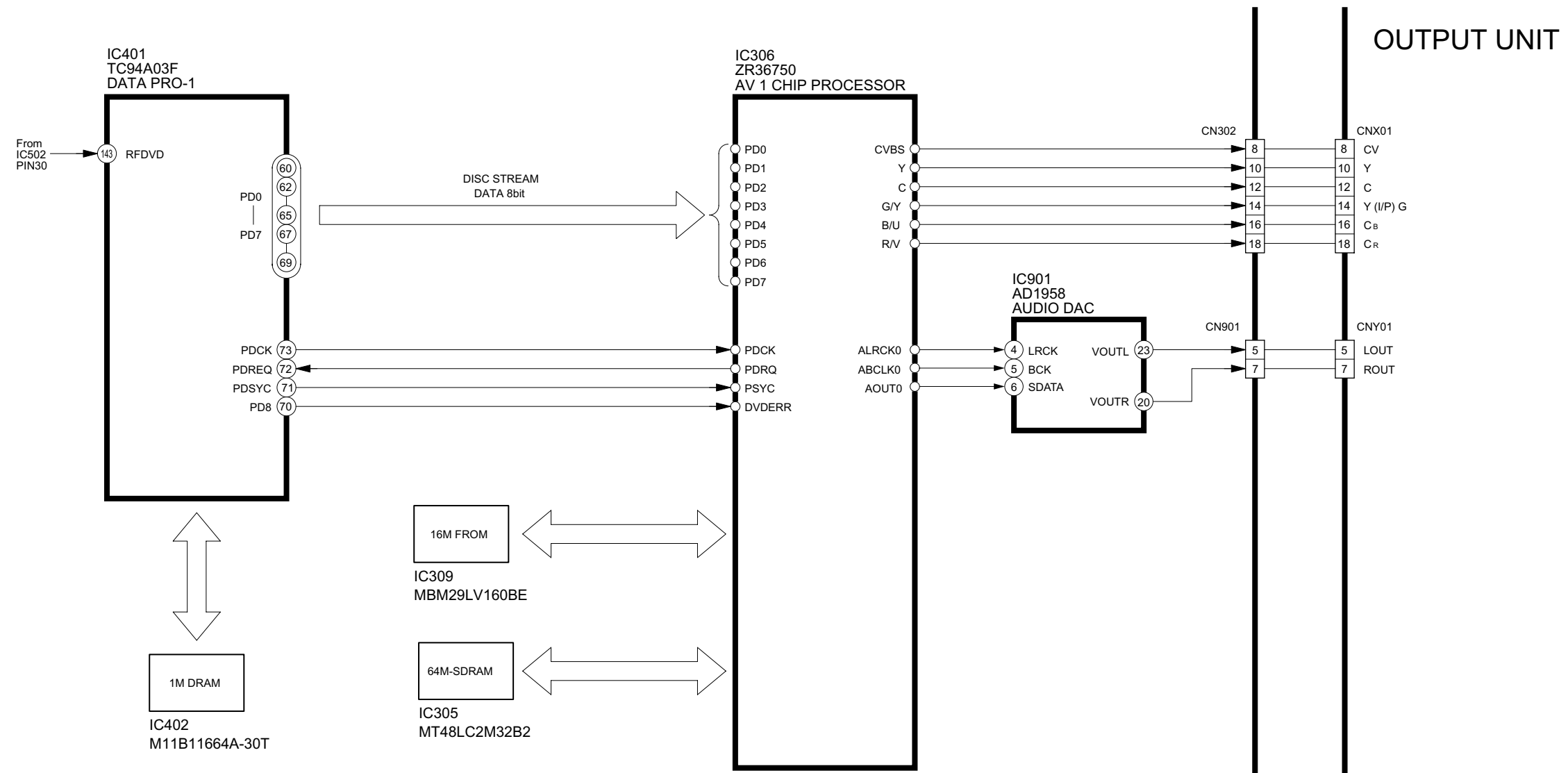

Fig. 3-4-7

4-5. (A) Output Block Diagram - DD-6030

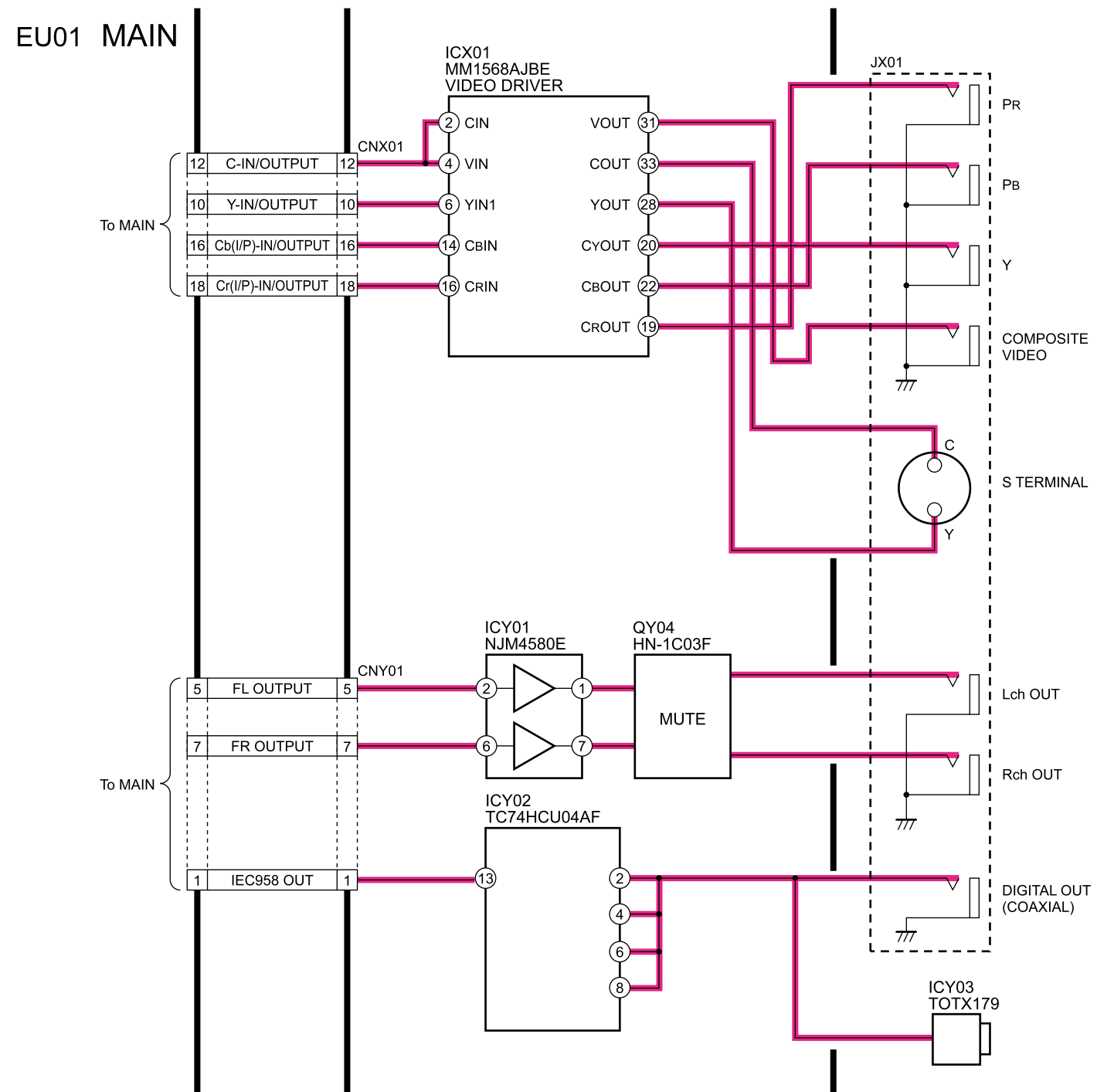

Fig. 3-4-8-A

4-5. (B) Output Block Diagram - DD-8030

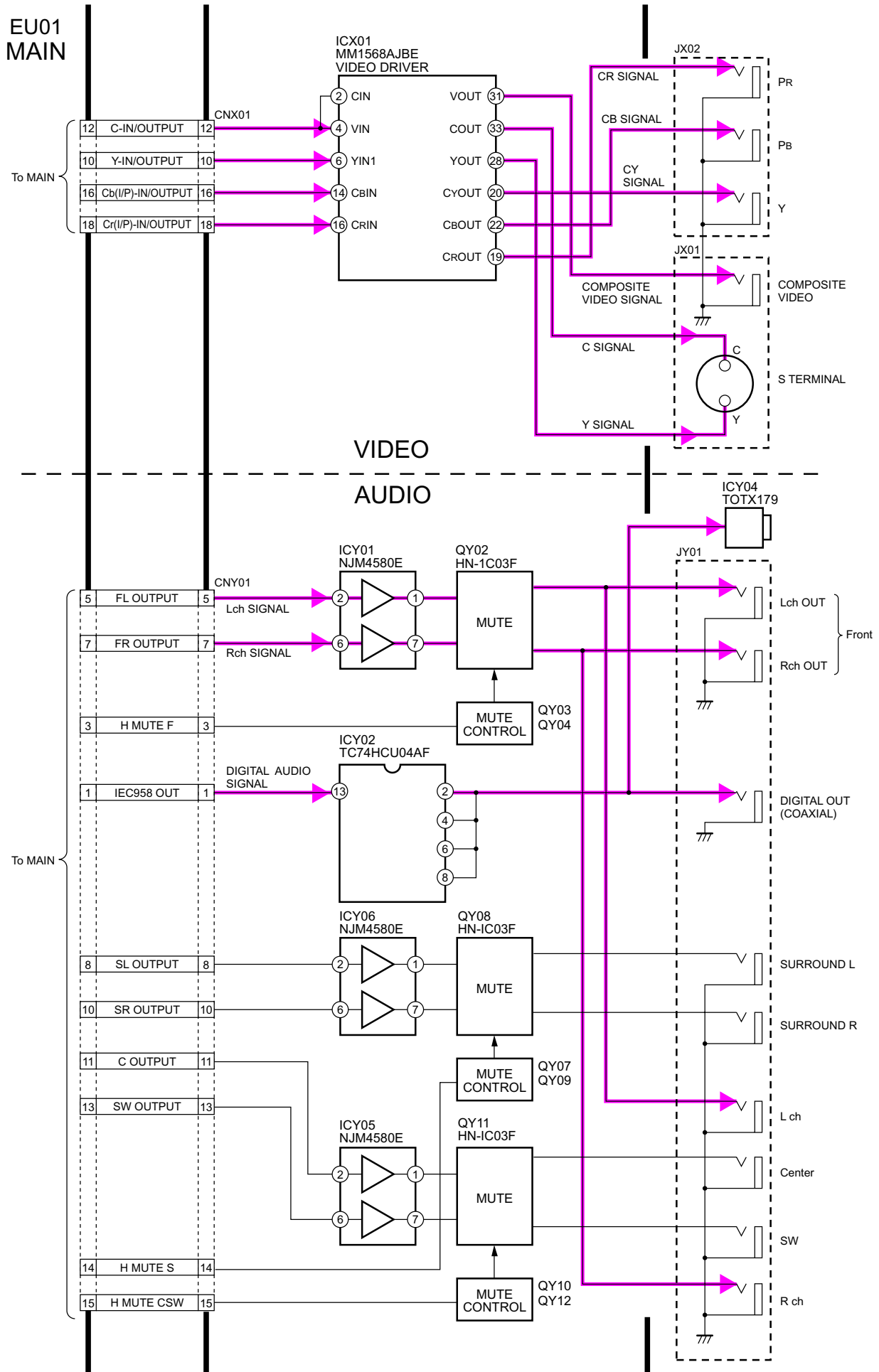

Fig. 3-4-8-B

5. CIRCUIT DIAGRAMS

5-1. Power Supply Circuit Diagram

EU02 POWER

: OFF (): ON []: PLAY

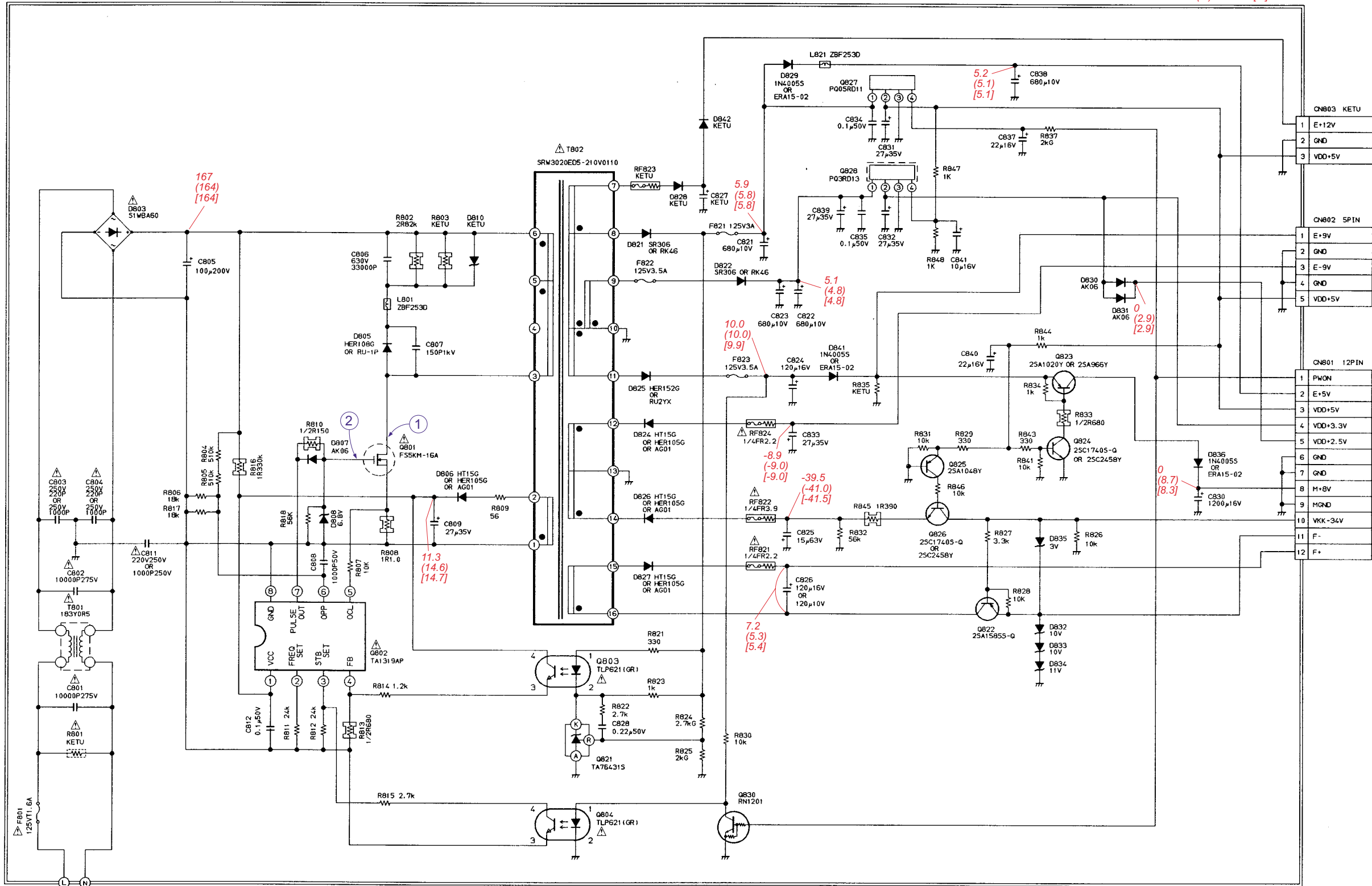

	Q802						Q821			Q822			Q823			Q824			Q825		
	①	②	③	④	⑥	⑧	K	R	A	E	C	B	E	C	B	E	C	B	E	C	B
OFF	11.3	1.5	0.5	2.8	1.5	0	3.9	2.5	0	0	-7.2	0	9.2	0	9.2	0	9.2	0	0	-39.0	0
ON	14.6	1.0	1.7	2.0	1.5	0	4.1	2.5	0	-30.3	-30.4	-31.0	9.4	9.3	8.7	0	0.1	0.7	0.7	-13.3	0
PLAY	14.7	1.0	1.7	2.0	1.5	0	4.1	2.5	0	-30.3	-30.4	-31.0	9.1	9.0	8.4	0	0.1	0.7	0.7	-13.3	0
	Q826			Q827			Q828			Q830											
	E	C	B	①	②	③	④	①	②	③	④	E	C	B							
OFF	-39.5	0	-39.0	5.9	5.0	0	0	5.1	3.3	0	0	0	1.0	0							
ON	-34.0	-34.0	-33.0	5.8	5.0	0	5.0	4.8	3.3	0	2.5	0	0.01	5.0							
PLAY	-34.0	-34.0	-33.0	5.8	5.0	0	5.0	4.8	3.3	0	2.5	0	0.01	5.0							

NOTE: "KETU" MEANS "NOT USED" ON THIS MODEL

Fig. 3-5-1

Power Supply Circuit Diagram

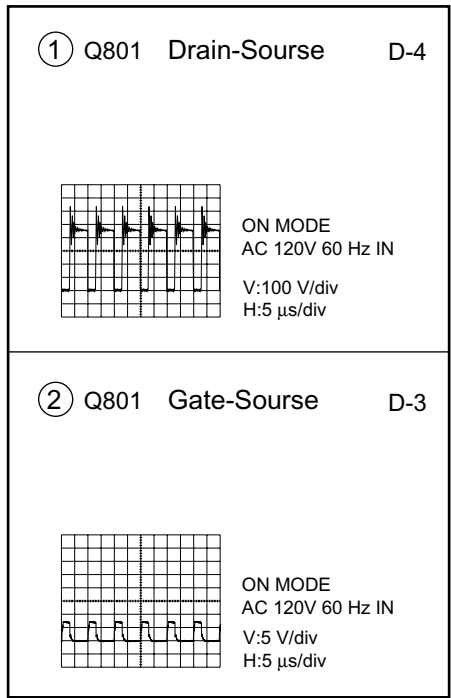

Fig. 3-5-2

5-2. Front Display , Power Switch Circuit Diagram

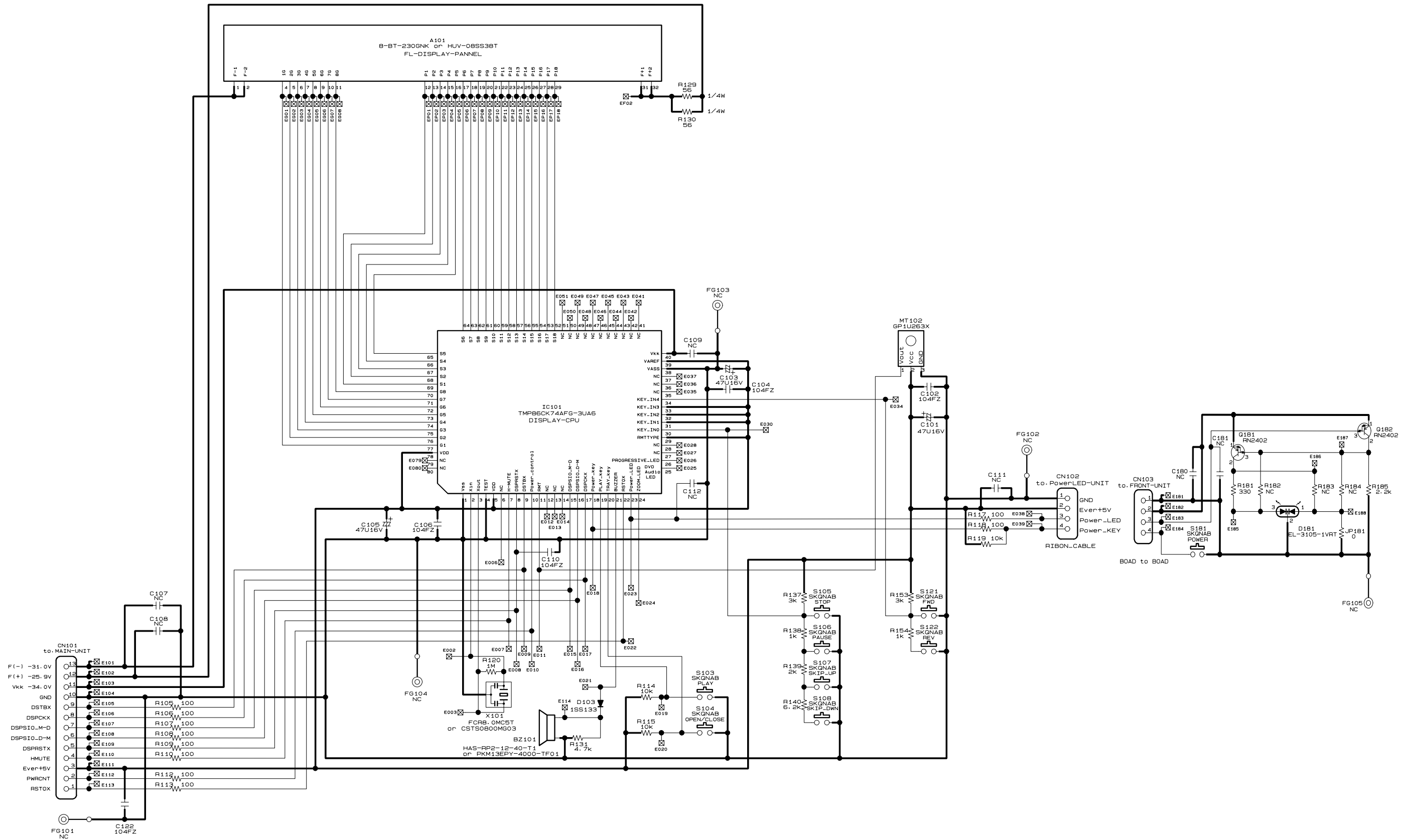

Fig. 3-5-3

Front Display, Power Switch Circuit Diagram

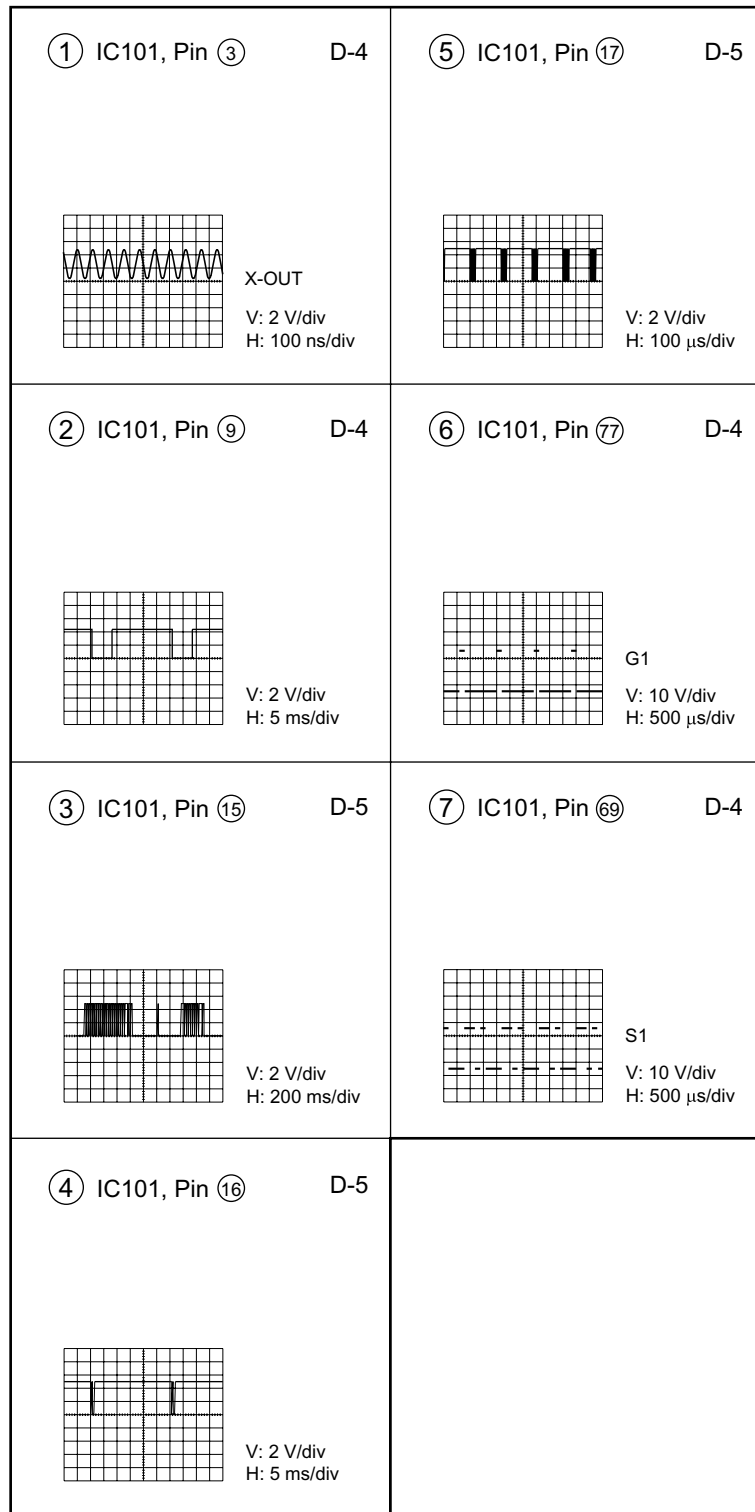
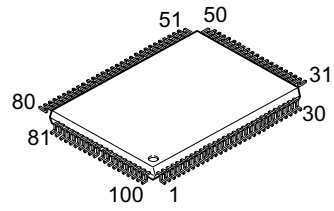

Fig. 3-5-4

5-3. Main Circuit Diagrams

5-3-1. Main ICs Information

TMP86CK74AFG



TC74VHCT
244AFT

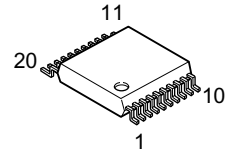

W986432DH

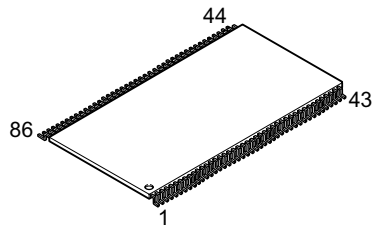

PCM1742

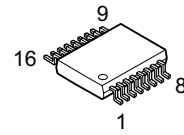

MBM29DL3240BE

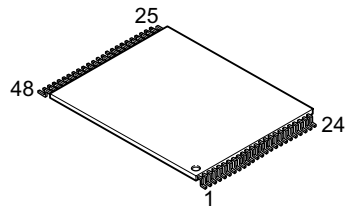

S24C02AFJA

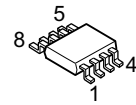

MM1568AJ

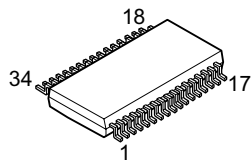

PQ3RD23
PQ05RD11

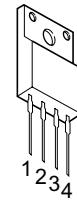

BH7863

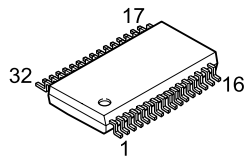

MPC2948T



AD1958YRS

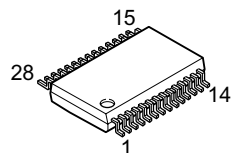

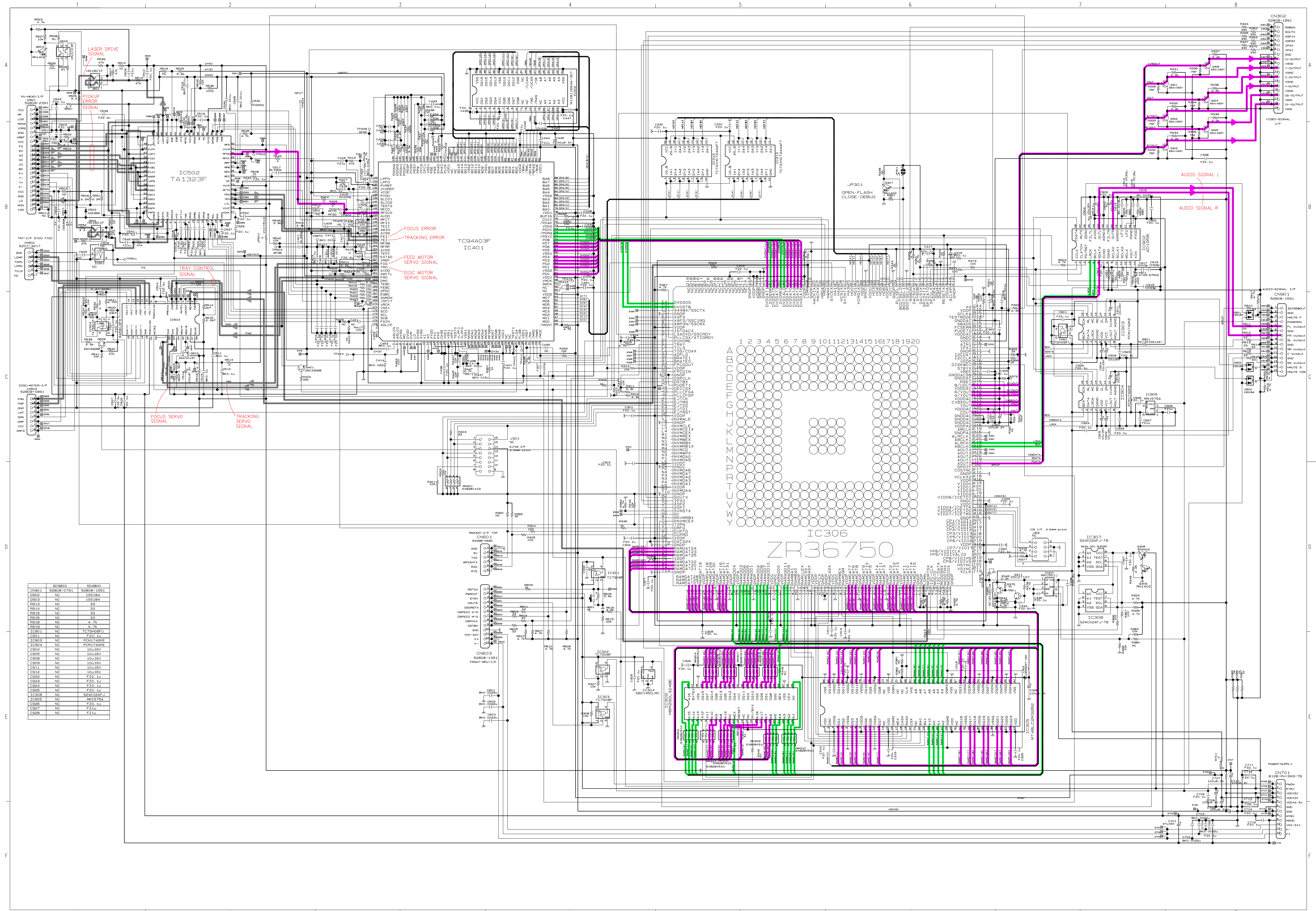

CN501	52808-0791	52808-1591
D902	NC	15S1B4
D903	NC	15S1B4
D913	NC	33
D914	NC	33
D915	NC	33
D916	NC	33
D918	NC	4.7K
D919	NC	4.7K
IC901	NC	TC7SH08FU
IC901	NC	F20.1U
IC903	NC	ICM1742KE
IC904	NC	ICM1742KE
IC904	NC	10u16V
C906	NC	10u16V
C909	NC	10u16V
C911	NC	10u16V
C912	NC	10u16V
C922	NC	F20.1U
C923	NC	F20.1U
C924	NC	F20.1U
C925	NC	F20.1U
IC905	NC	52402AFJ-TB
IC905	NC	MS1075A
C926	NC	F20.1U
C927	NC	F21U
C928	NC	F21U

5-3-2. Main Circuit Diagram

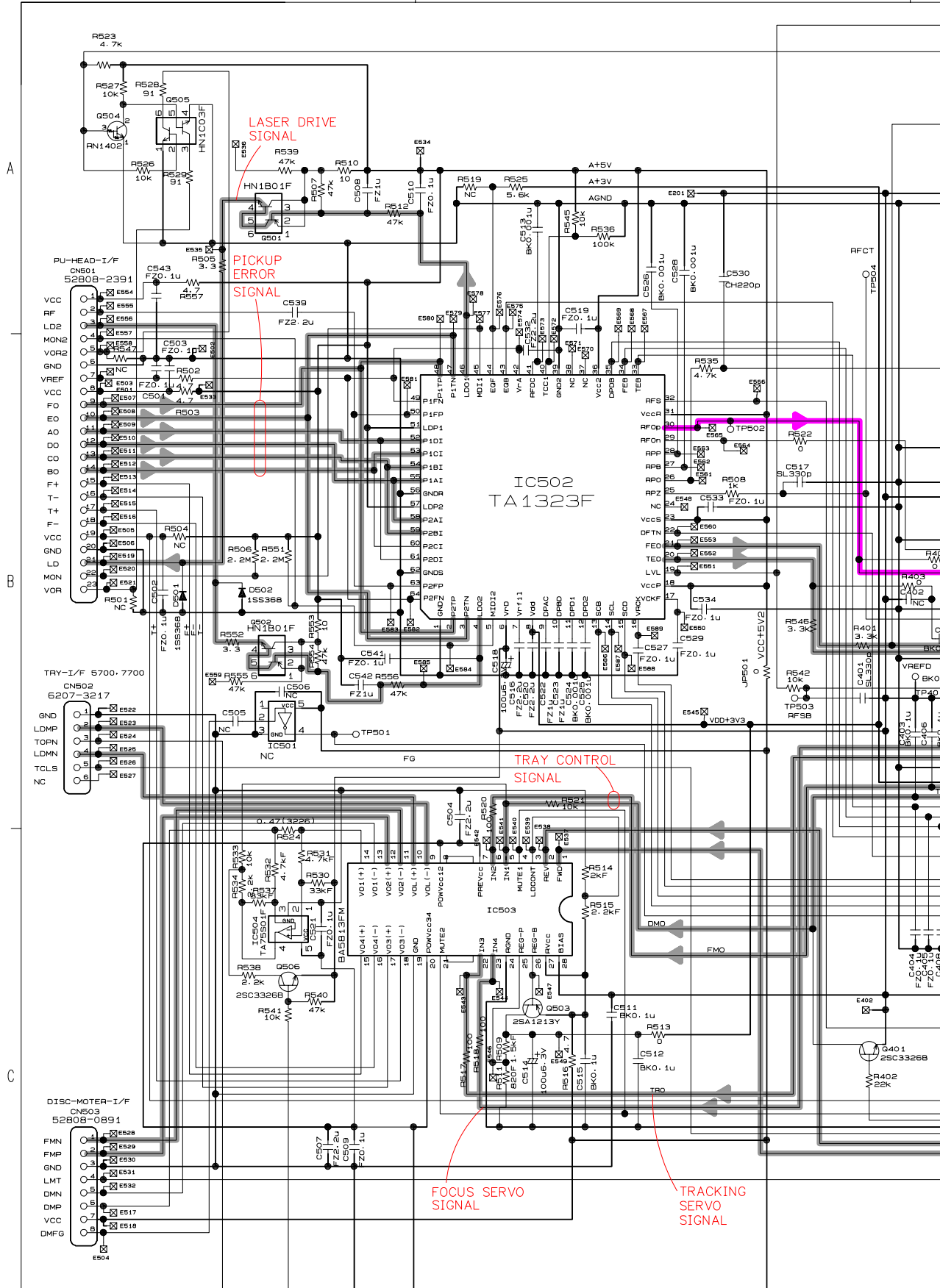

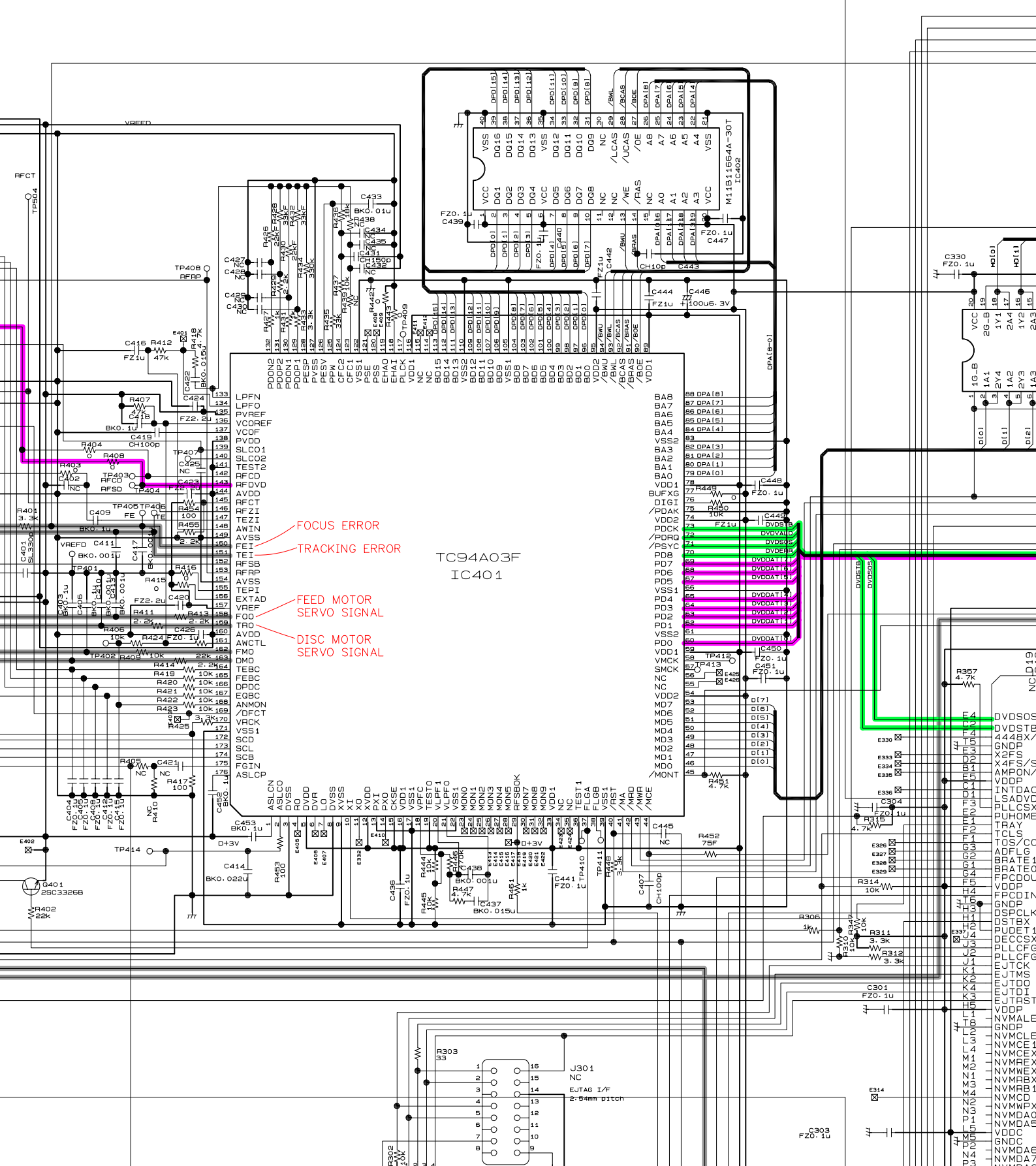

FOCUS ERROR
TRACKING ERROR
FEED MOTOR SERVO SIGNAL
DISC MOTOR SERVO SIGNAL

TC940A03F
IC9401

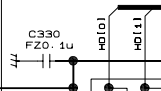
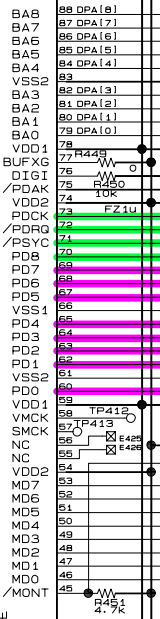
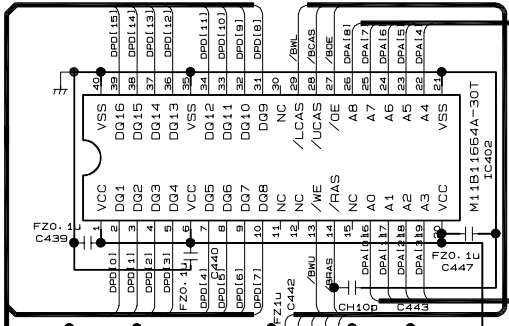

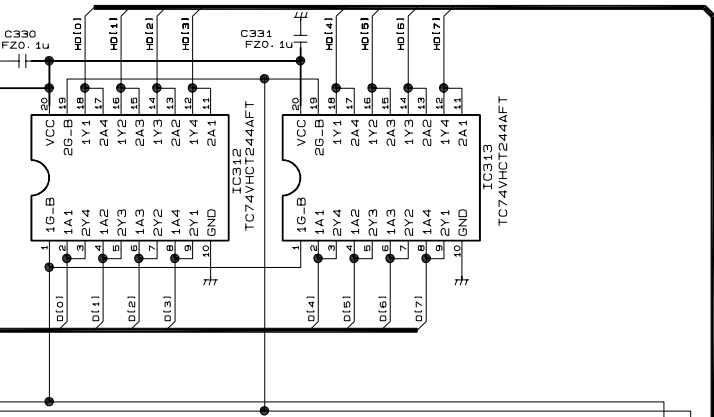

JP301
 OPEN : FLASH
 CLOSE : DEBUG

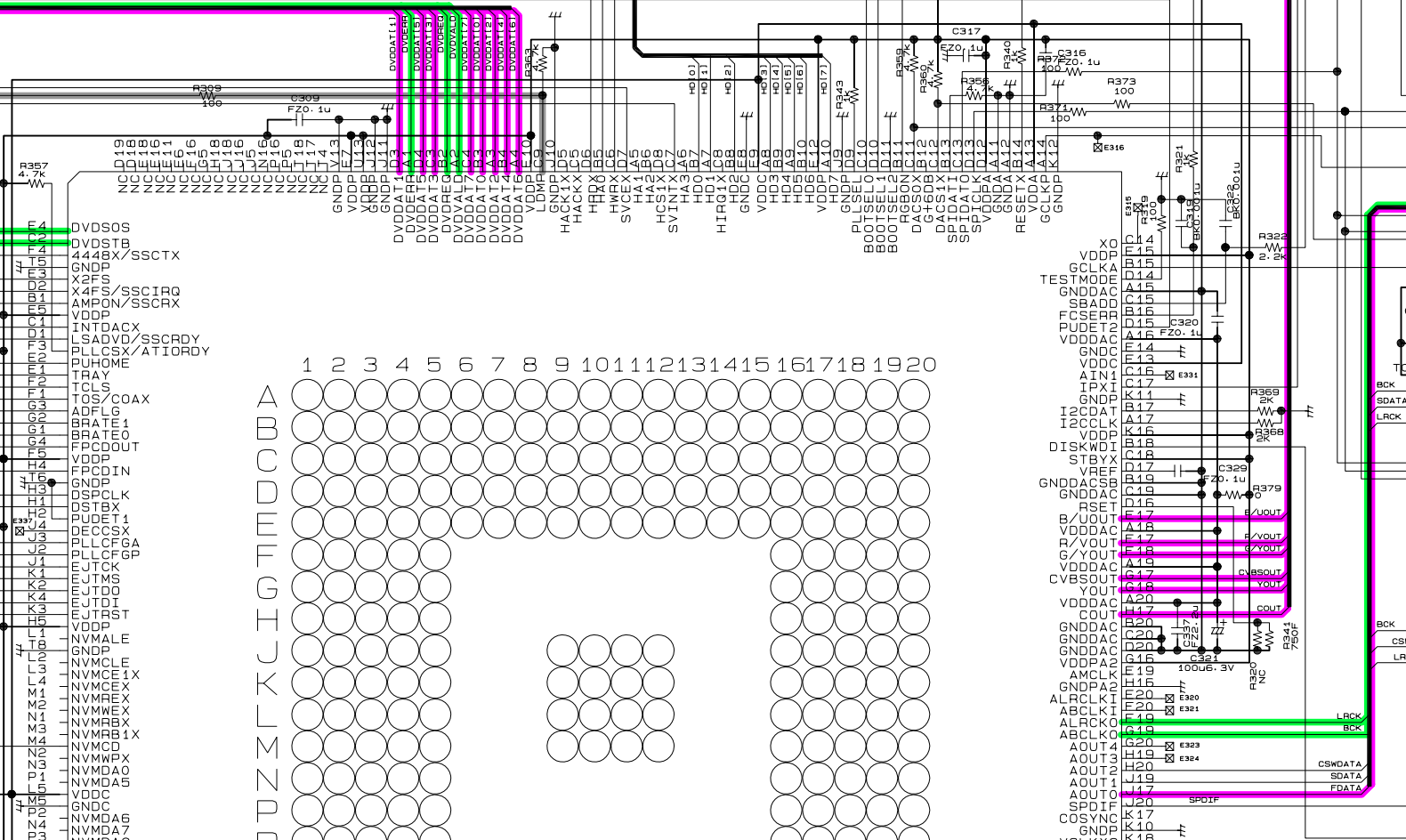

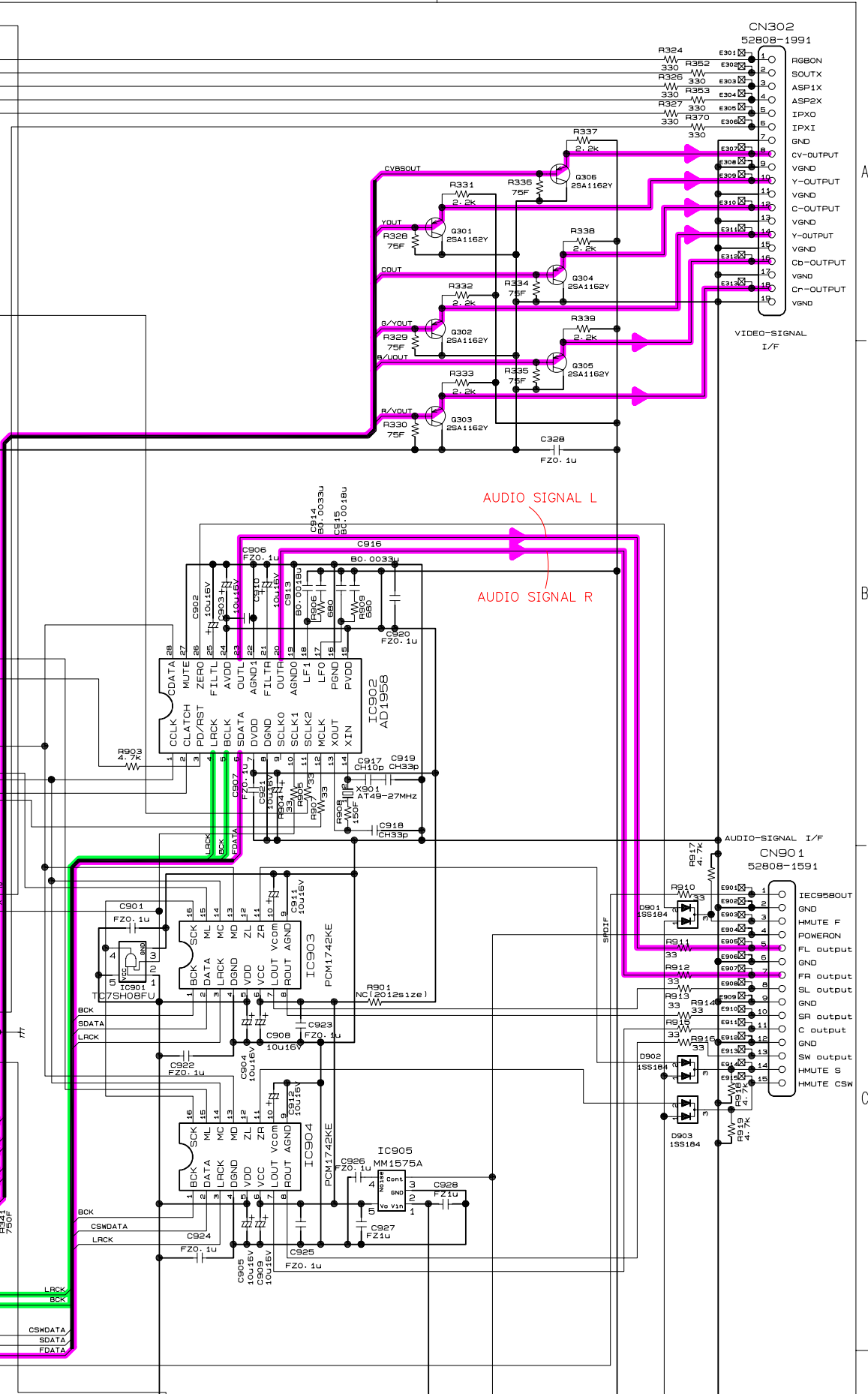

D

	SD3800	SD4800
CN901	52808-0791	52808-1591
D902	NC	1SS184
D903	NC	1SS184
R913	NC	33
R914	NC	33
R915	NC	33
R916	NC	33
R918	NC	4.7k
R919	NC	4.7k
IC901	NC	TC7SH08FU
C901	NC	FZO. 1u
IC903	NC	PCM1742KE
IC904	NC	PCM1742KE
C904	NC	10u16V
C905	NC	10u16V
C908	NC	10u16V
C909	NC	10u16V
C911	NC	10u16V
C912	NC	10u16V
C922	NC	FZO. 1u
C923	NC	FZO. 1u
C924	NC	FZO. 1u
C925	NC	FZO. 1u
IC308	NC	S24C02AFJ
IC905	NC	MM1575A
C926	NC	FZO. 1u
C927	NC	FZ1u
C928	NC	FZ1u

E

F

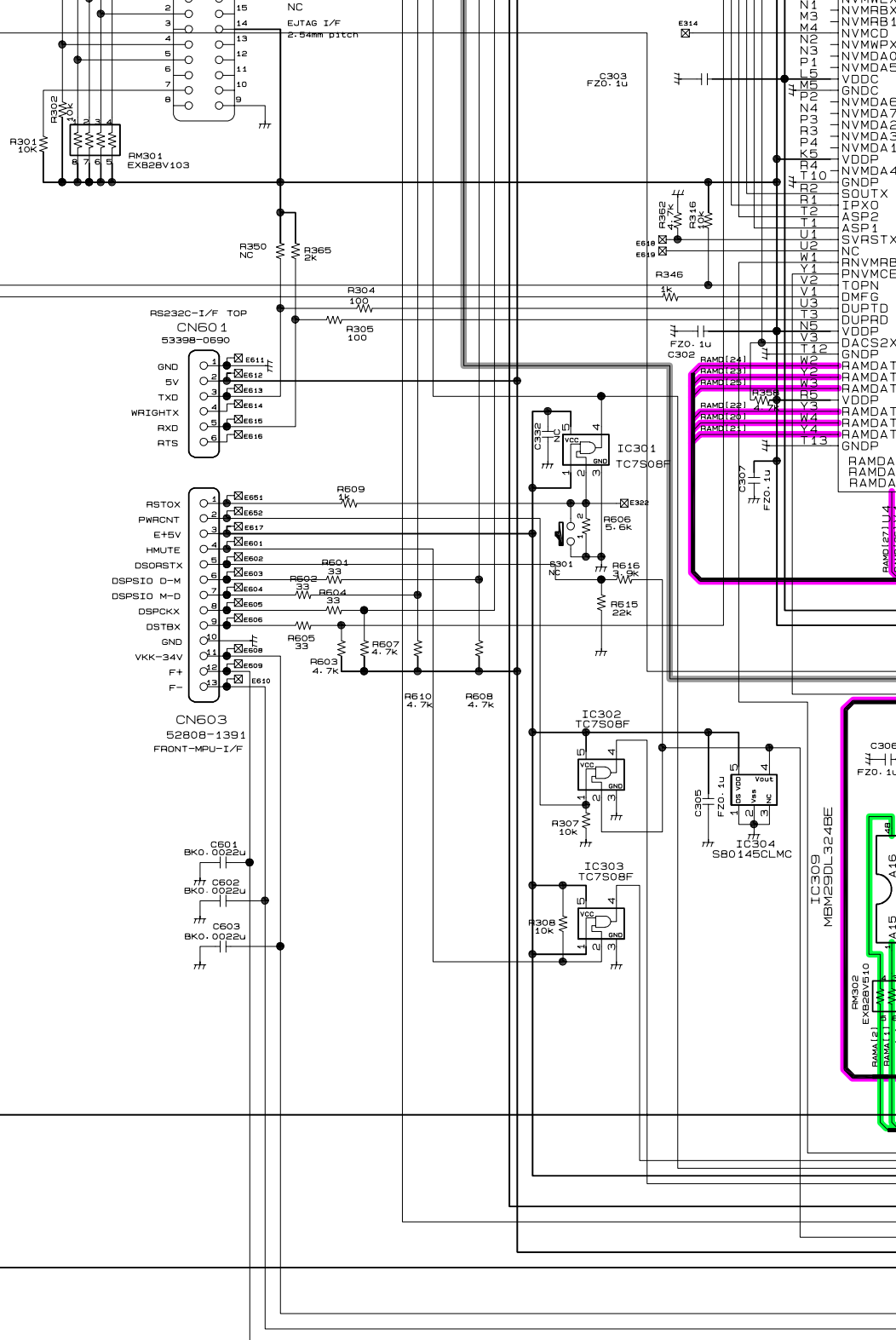

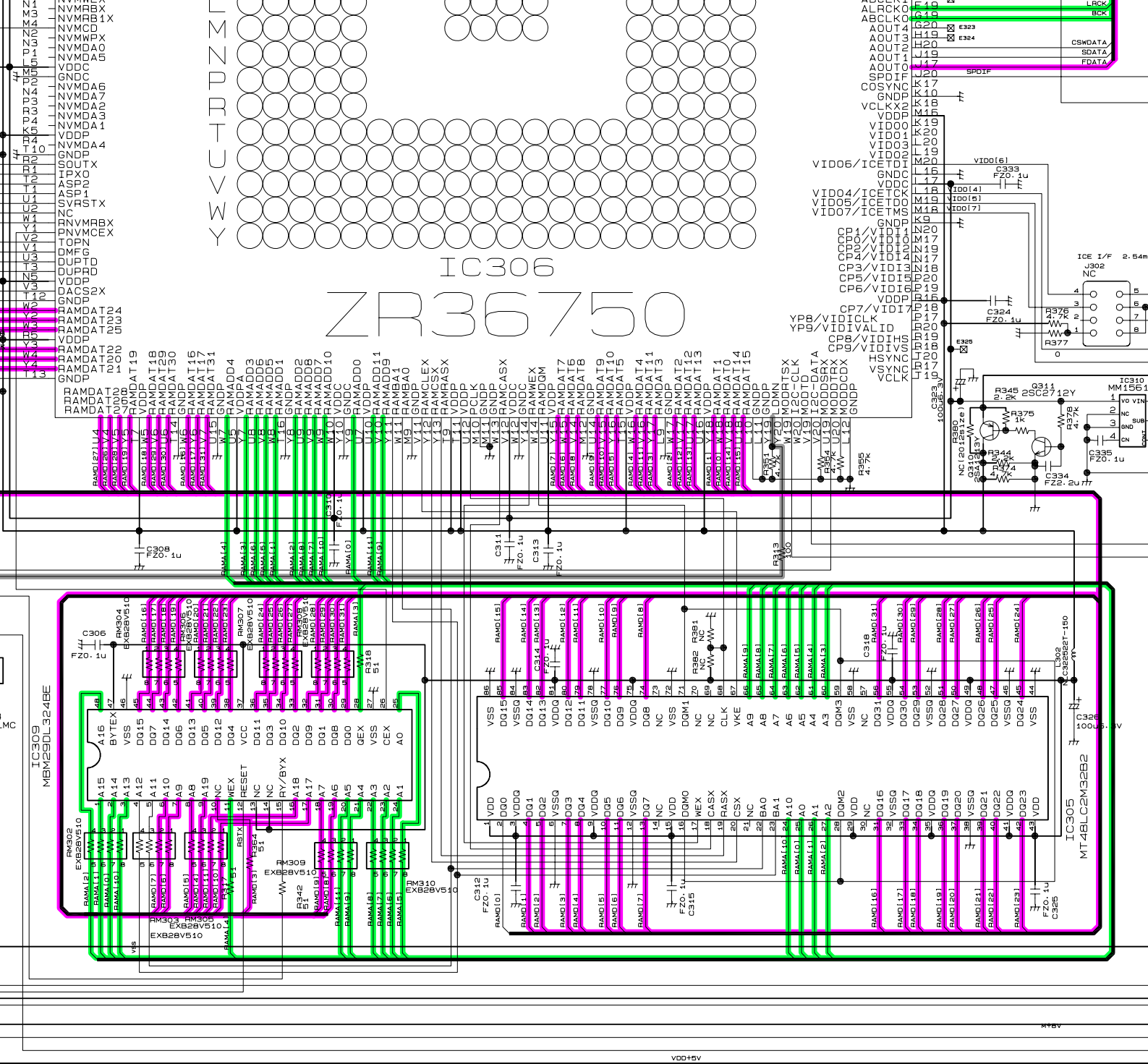

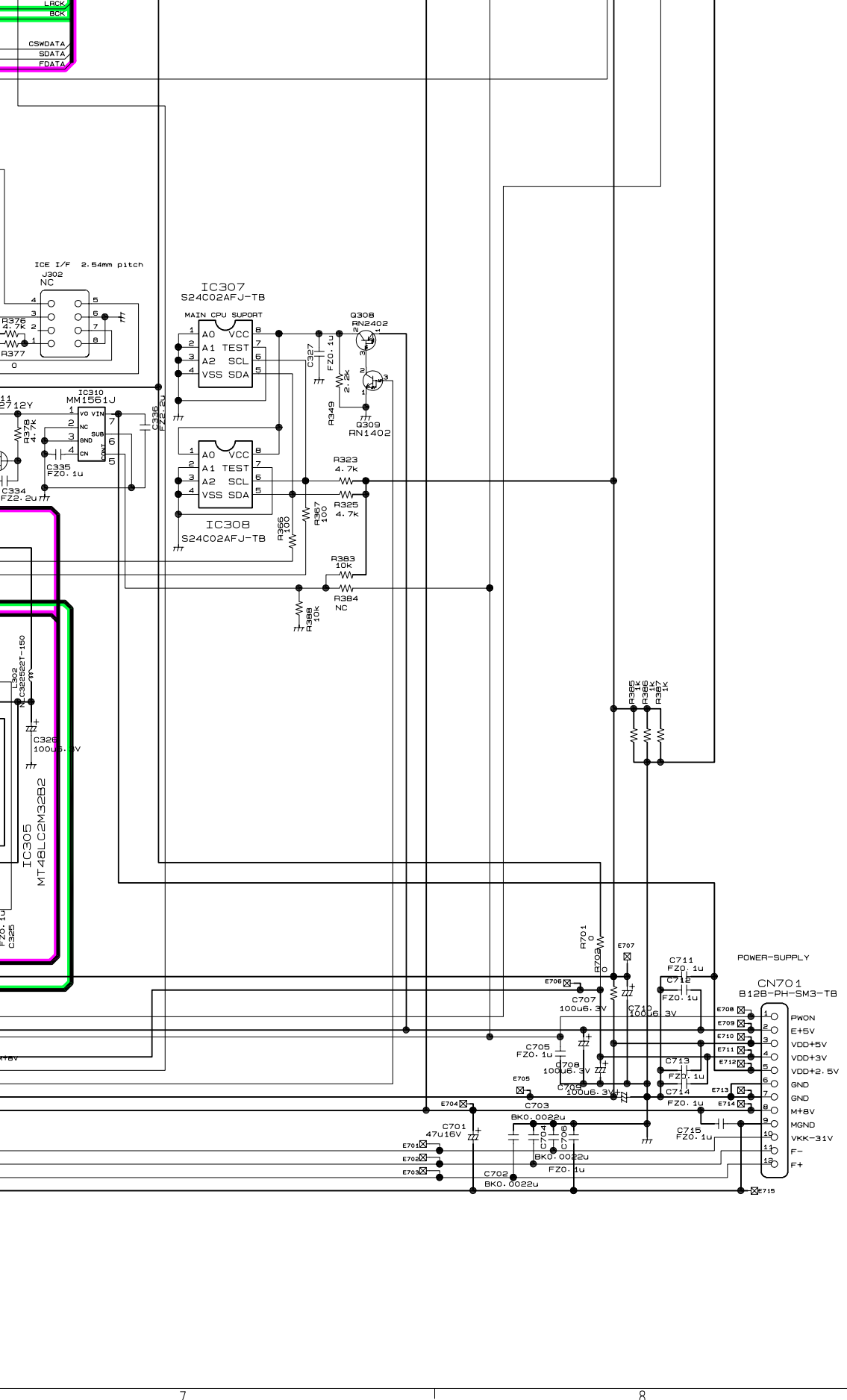

D
E
F

Fig. 3-5-5

5-4. (A) Output Circuit Diagram - DD-6030

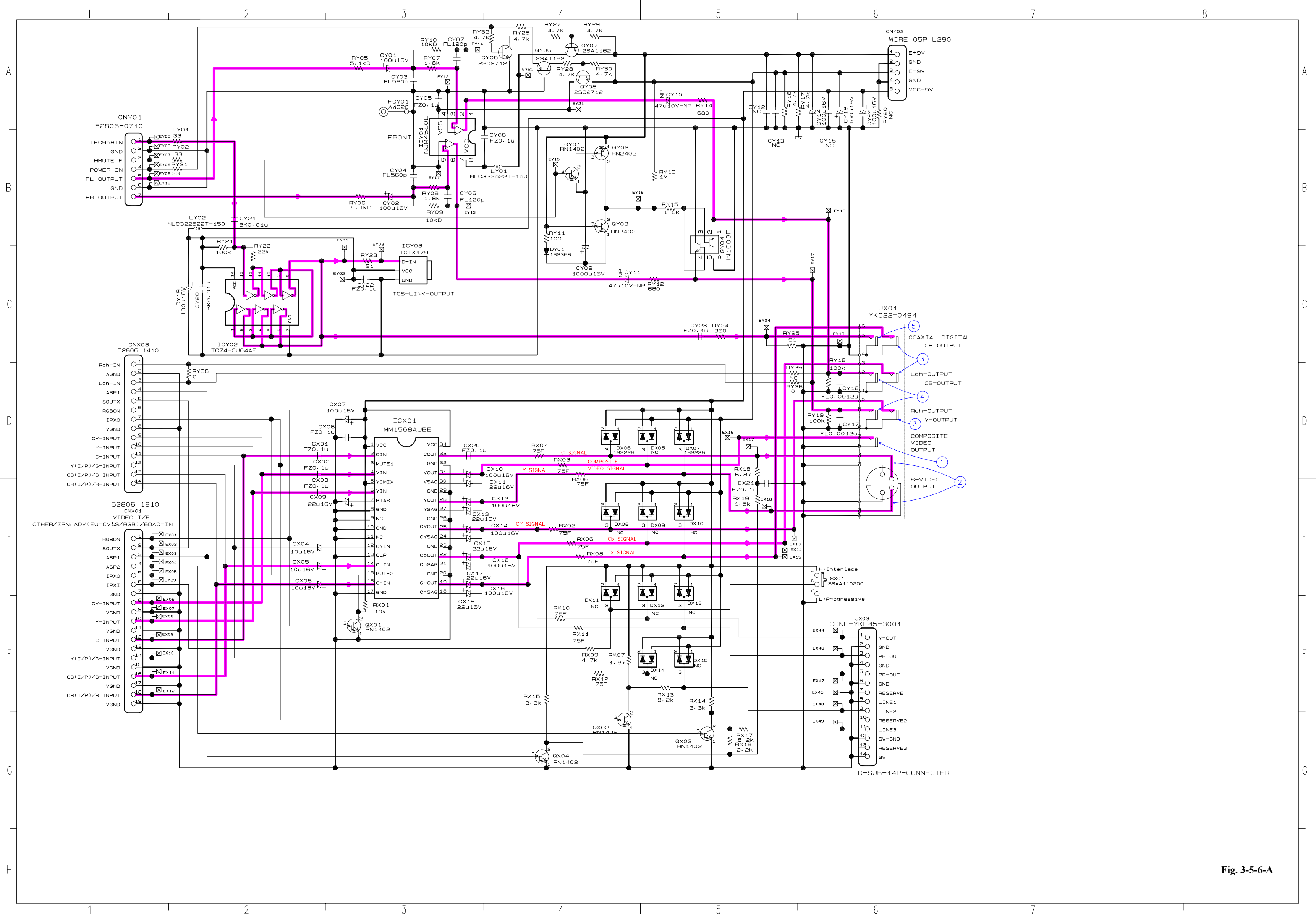
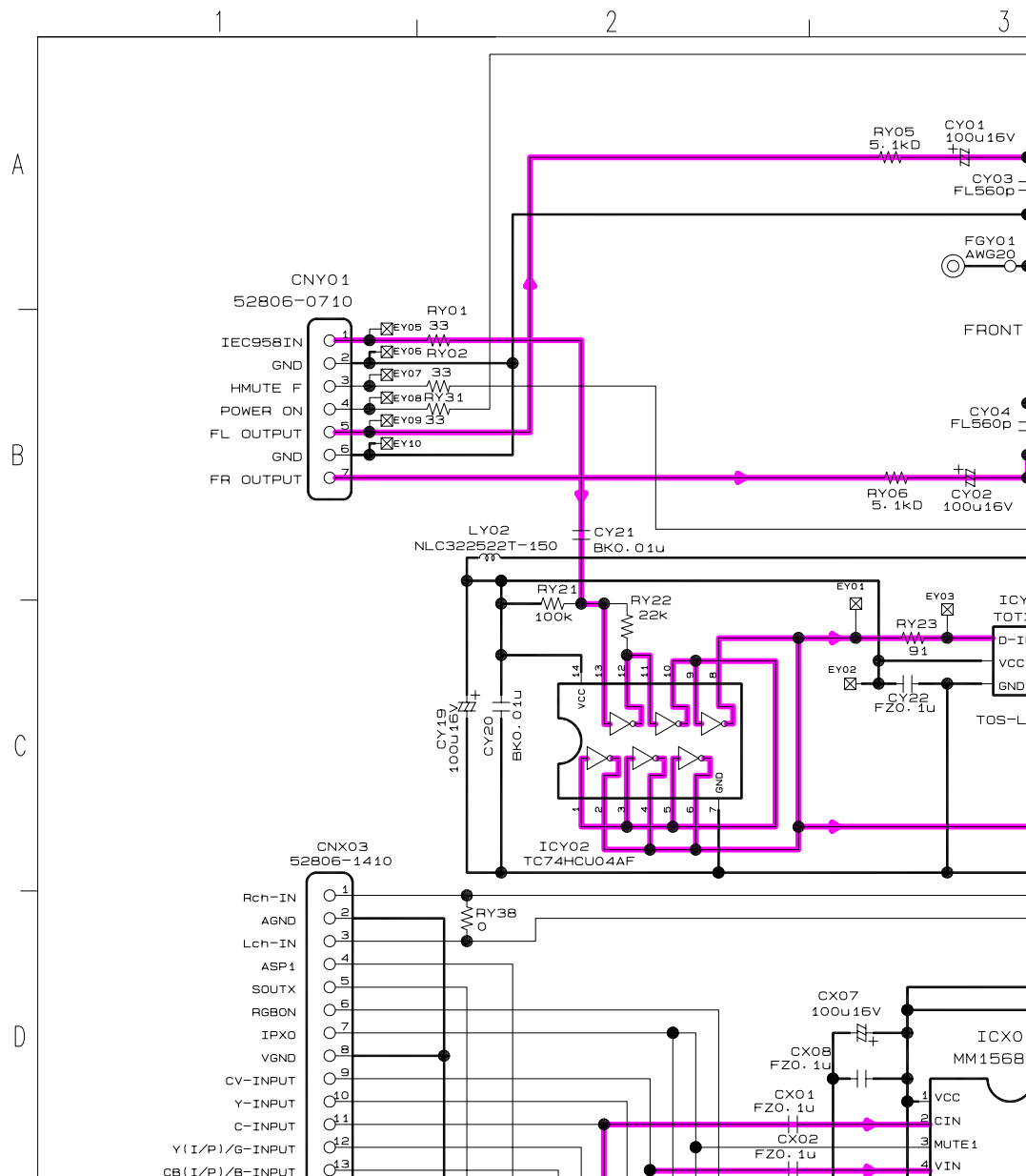
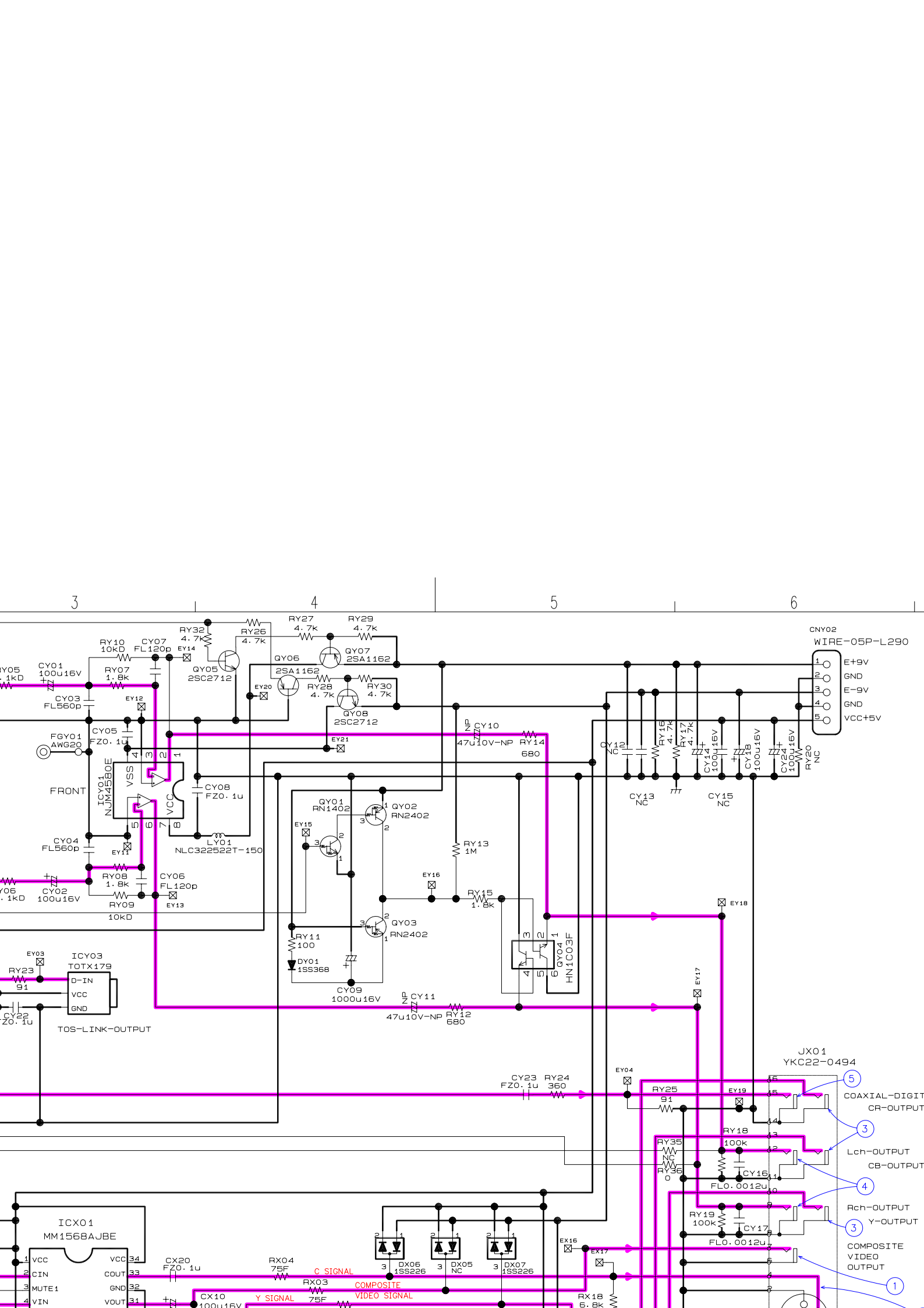

Fig. 3-5-6-A

5-4. (A) Output Circuit Diagram - DD-6030





7

8

E-05P-L290

E+9V
GND
E-9V
GND
VCC+5V

A

B

C

D

494

5
COAXIAL-DIGITAL
CR-OUTPUT

3
Lch-OUTPUT
CB-OUTPUT

4
Rch-OUTPUT
Y-OUTPUT

3
COMPOSITE
VIDEO
OUTPUT

1

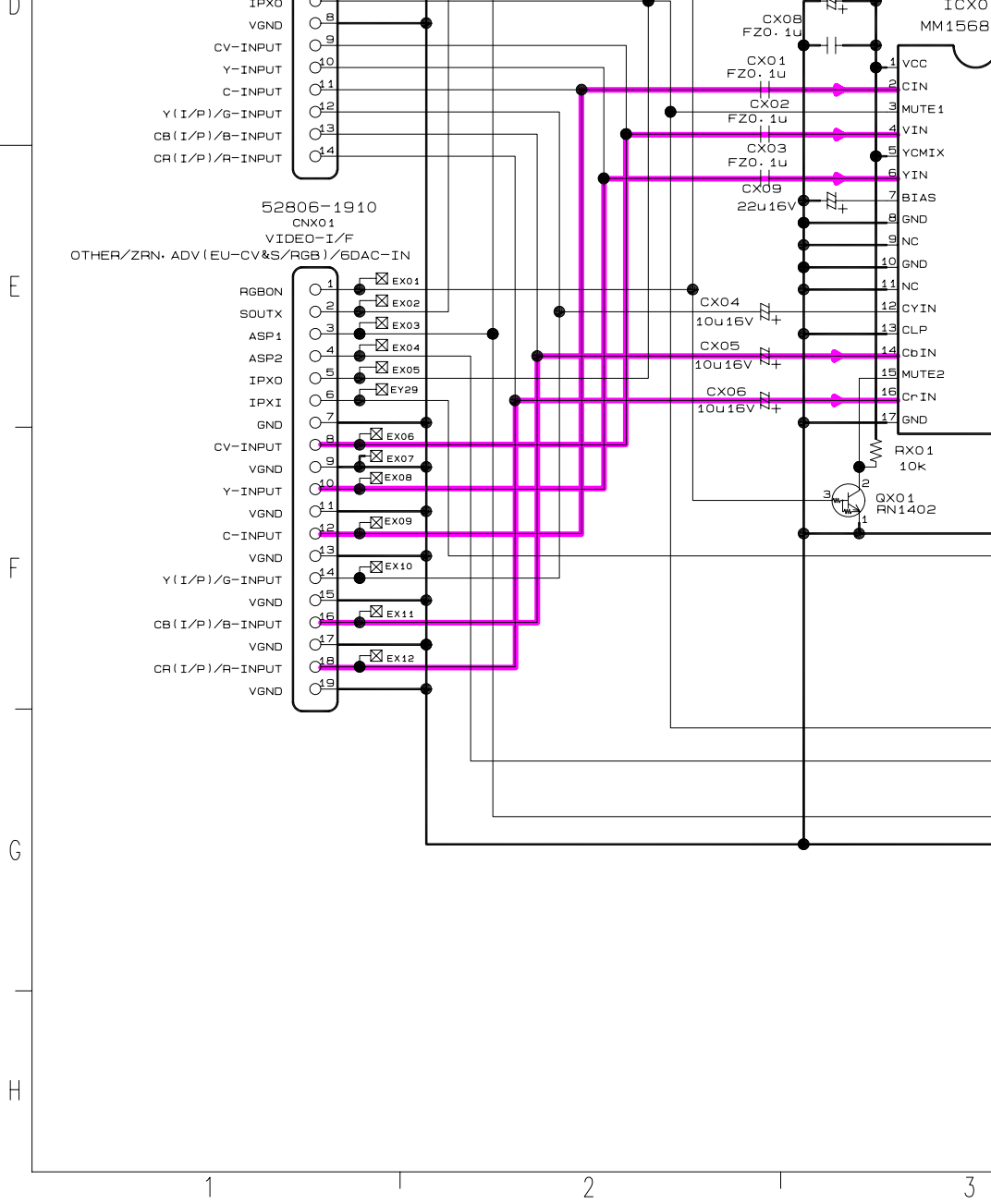

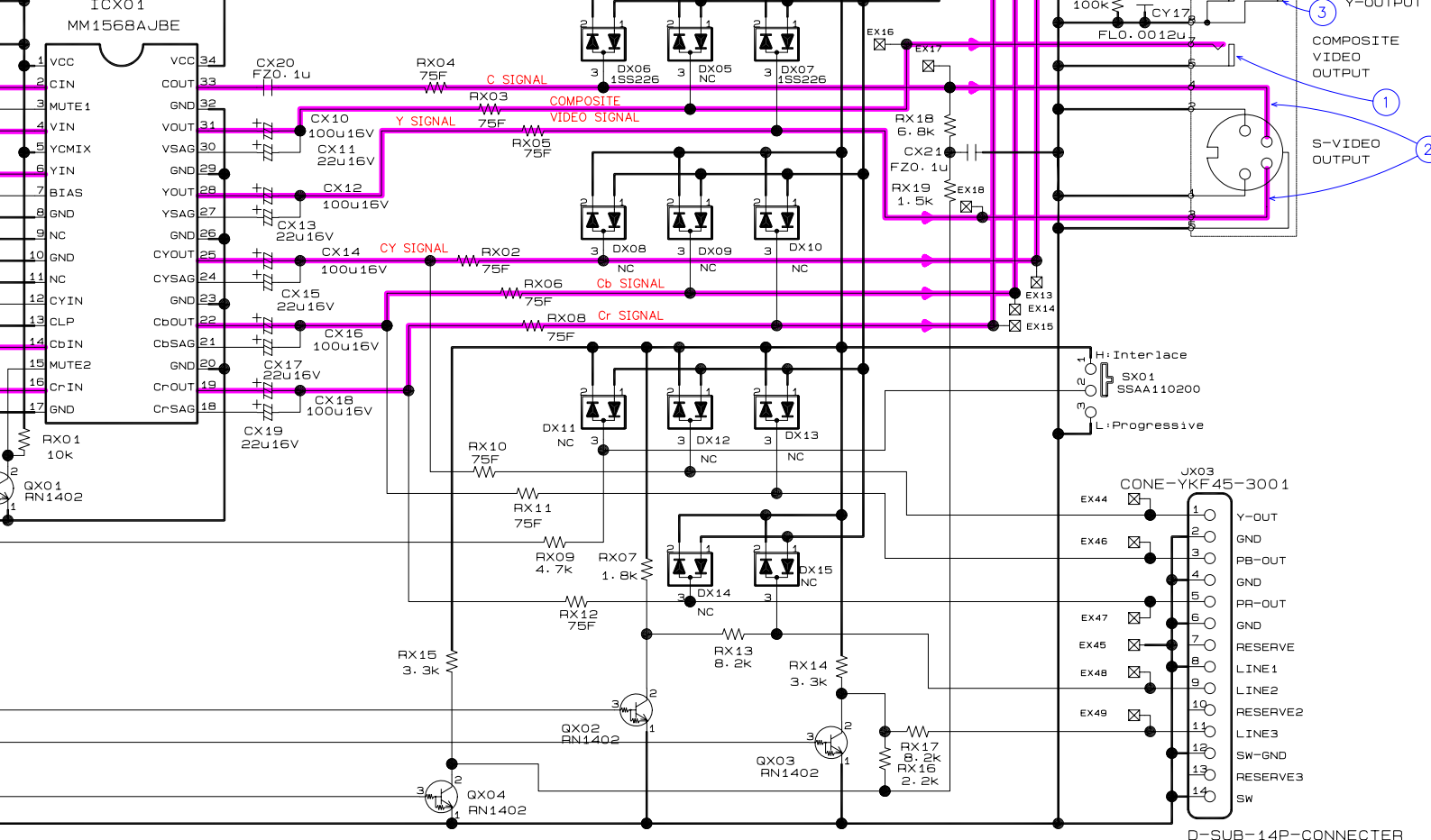

3

4

5

6

3 Y-OUTPUT
COMPOSITE
VIDEO
OUTPUT
1
S-VIDEO
OUTPUT
2

2

3

-CONNECTER

D

E

F

G

Fig. 3-5-6-A

7

Output Circuit Diagram - DD-6030

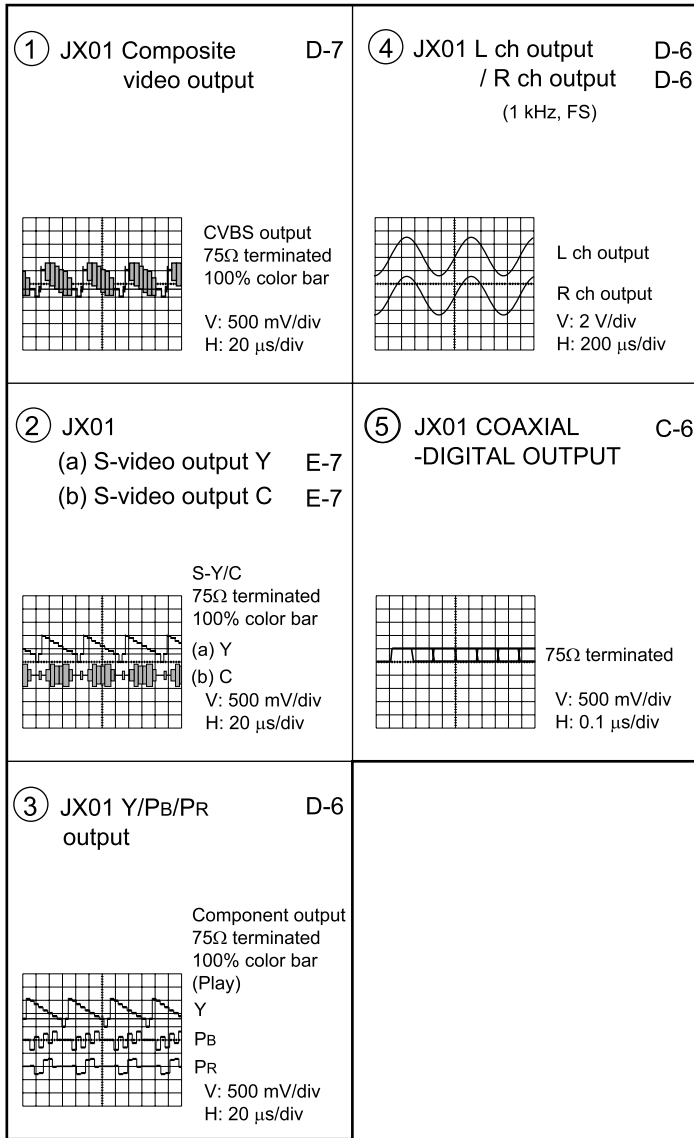

Fig. 3-5-7-A

5-4. (B) Output Circuit Diagram - DD-8030

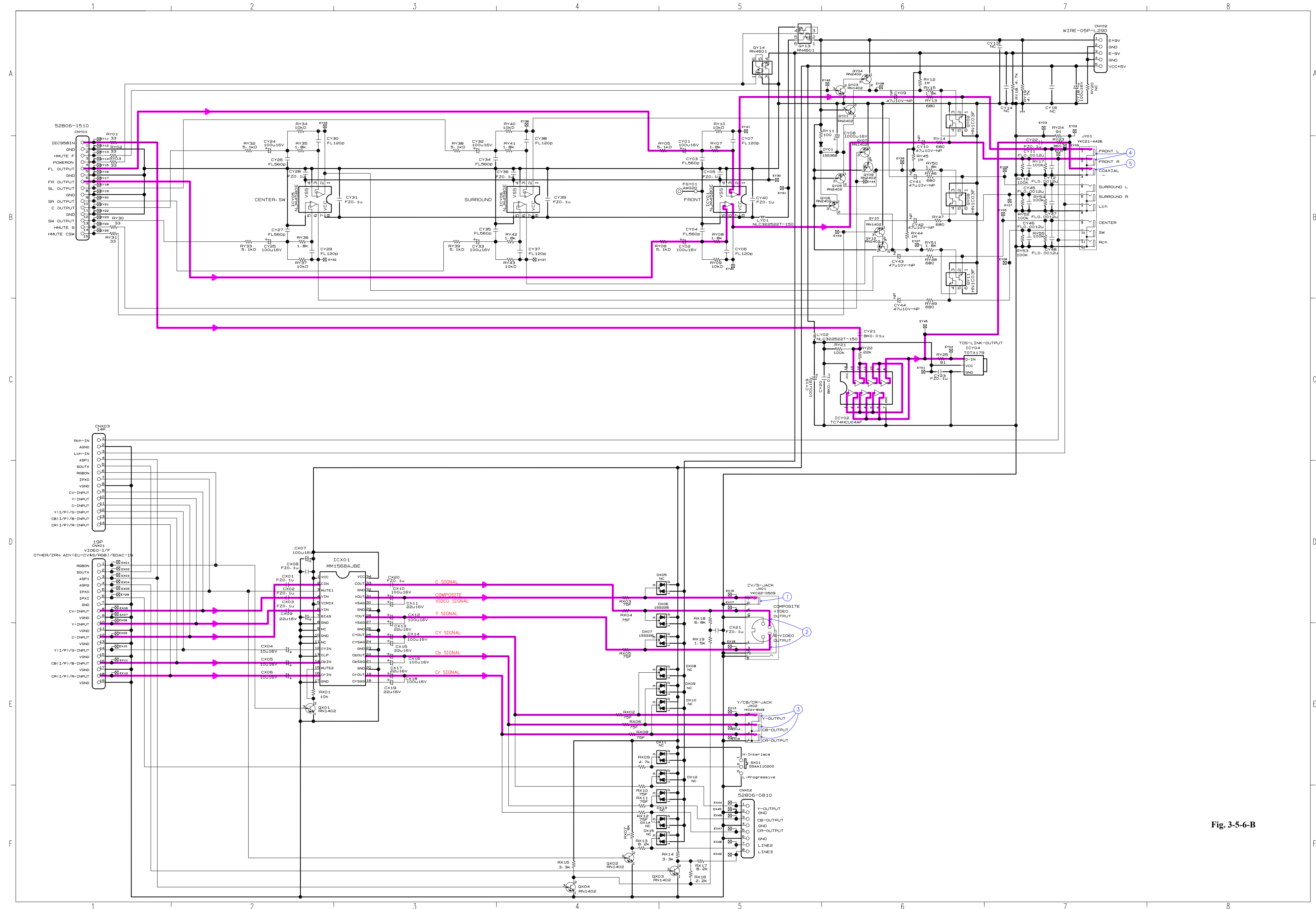
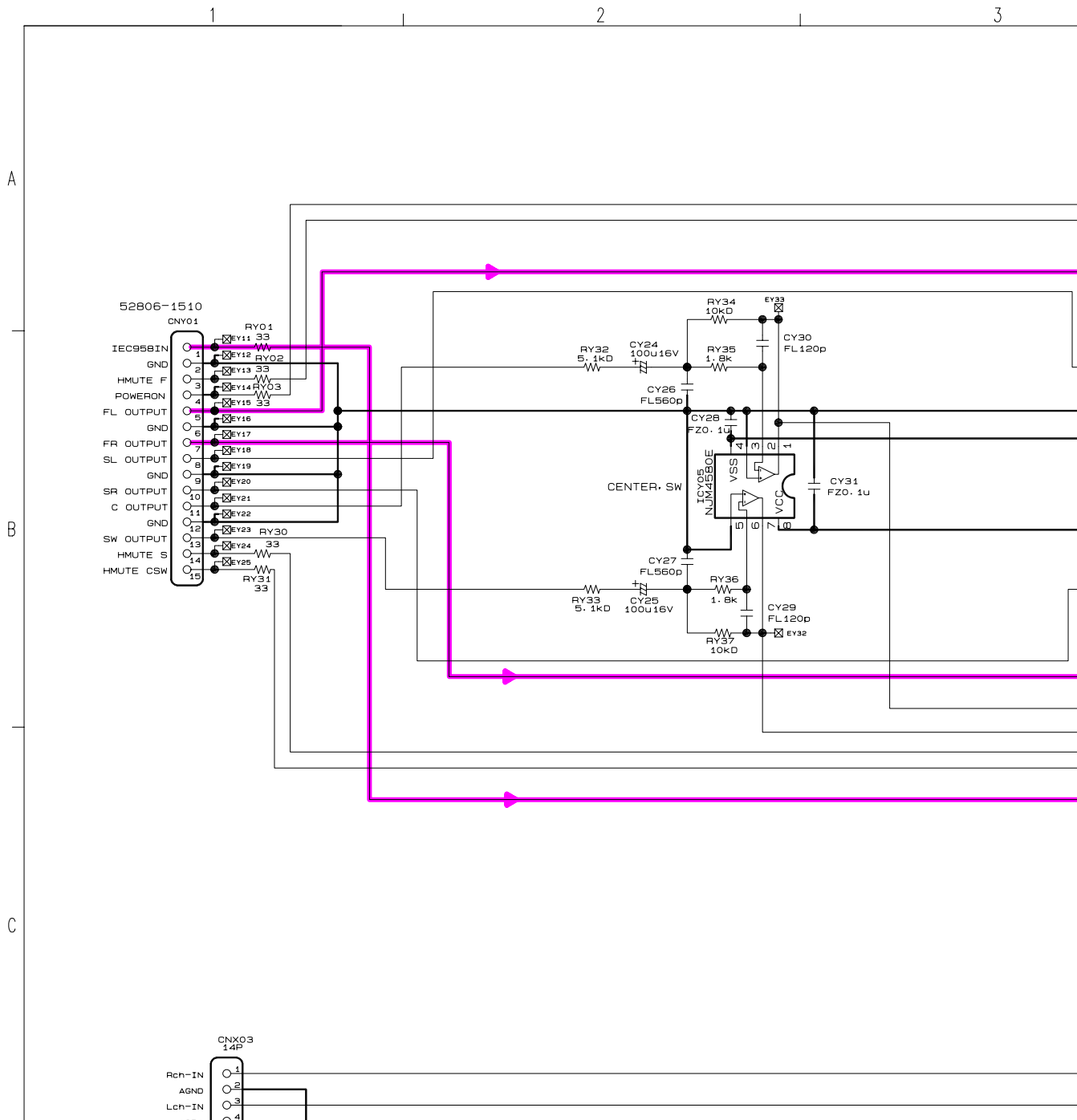
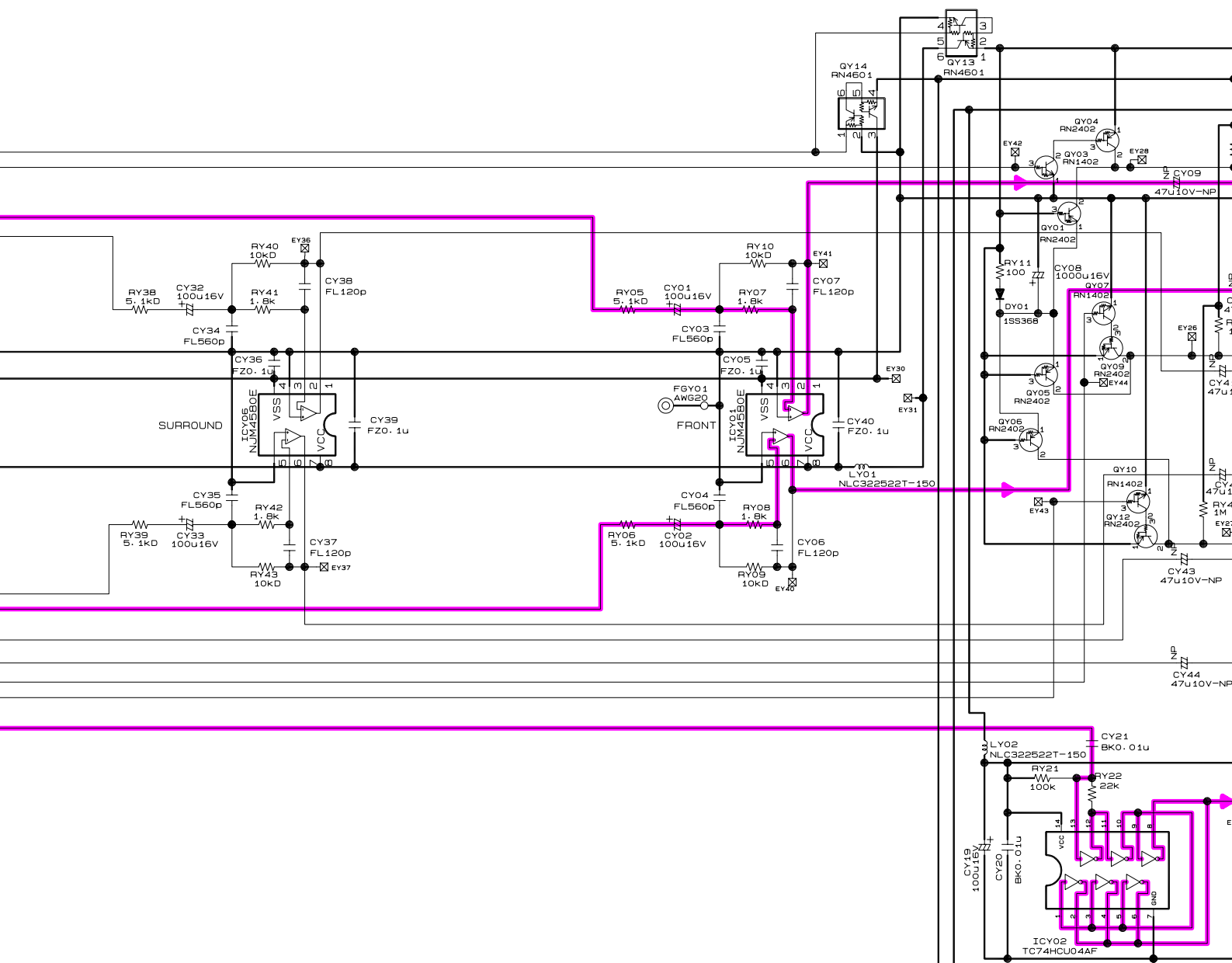
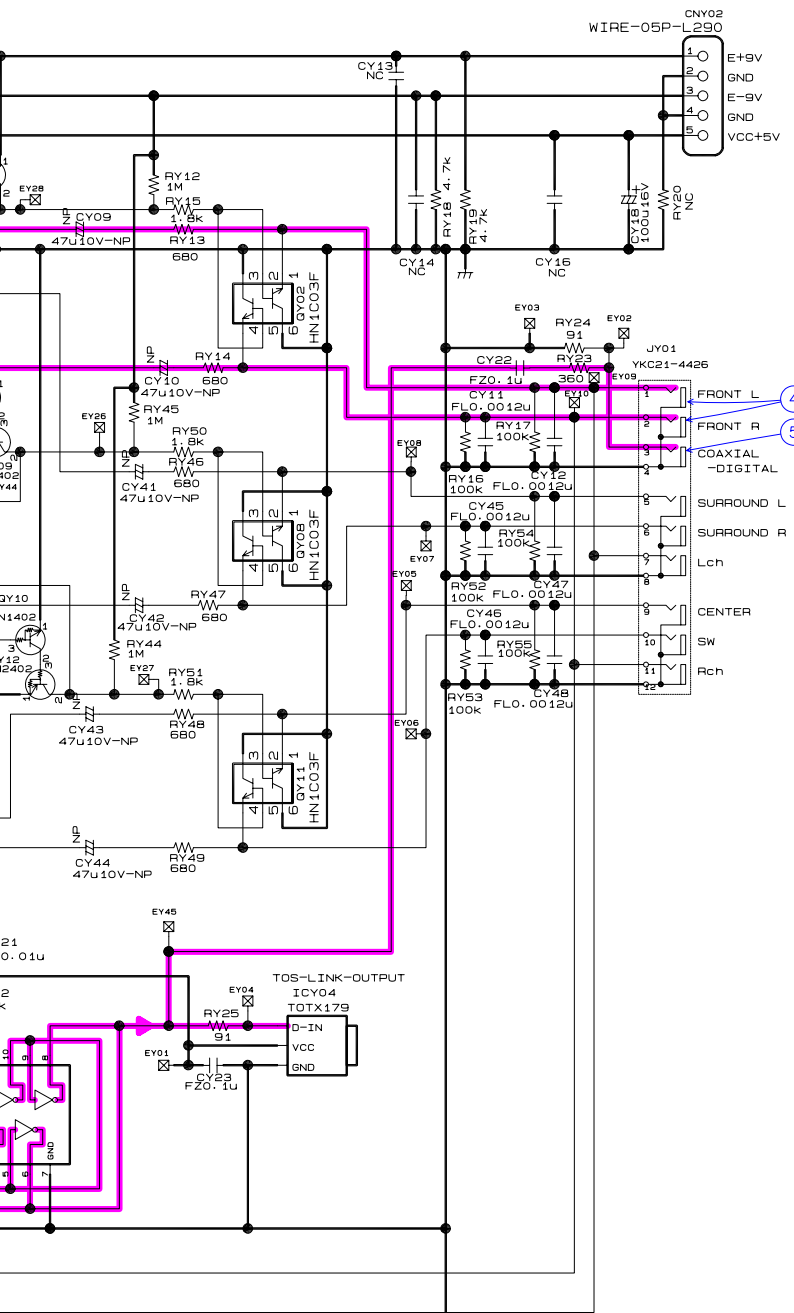

Fig. 3-5-6-B

5-4. (B) Output Circuit Diagram - DD-8030







A

B

C

D
E
F

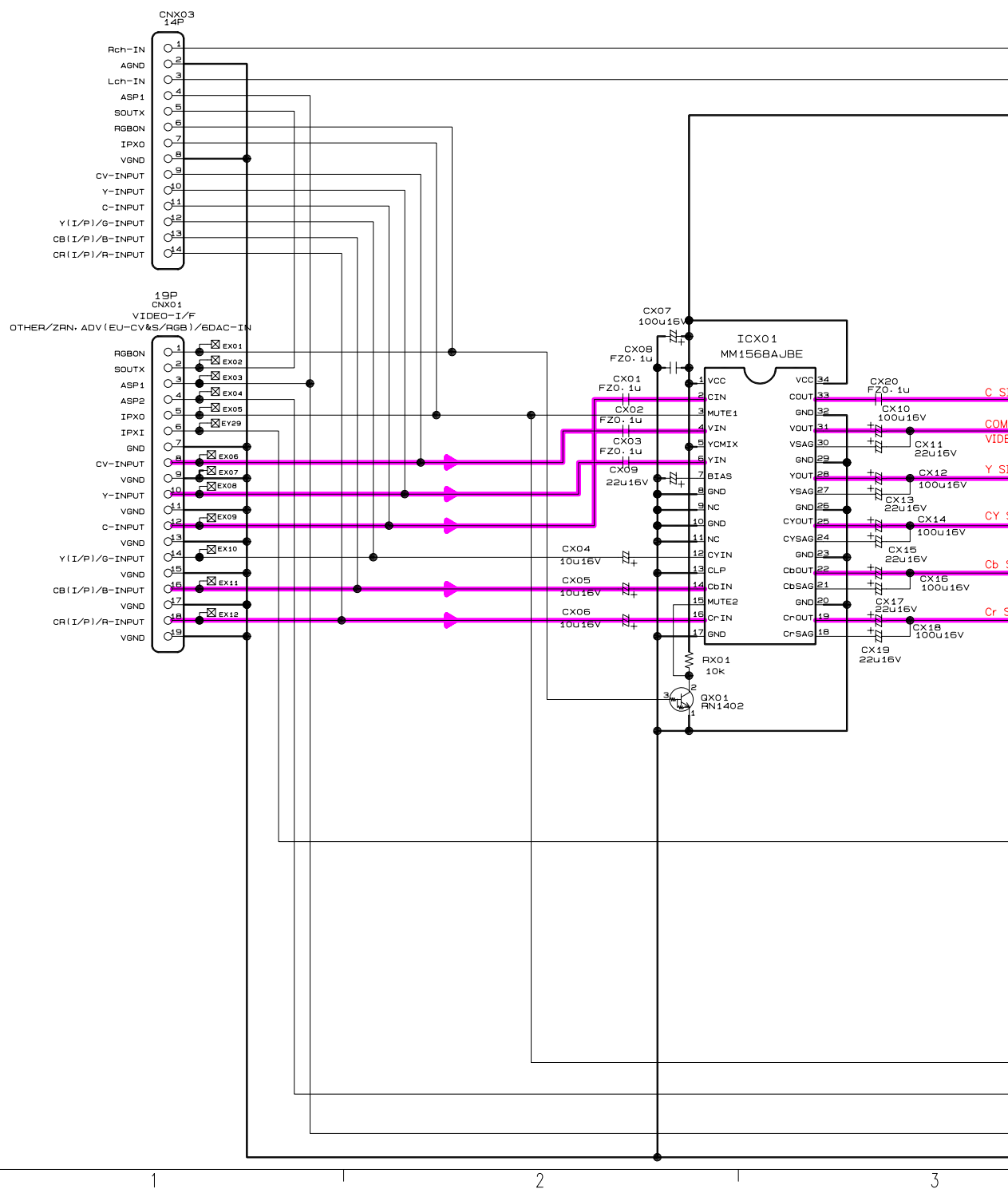

1 2 3

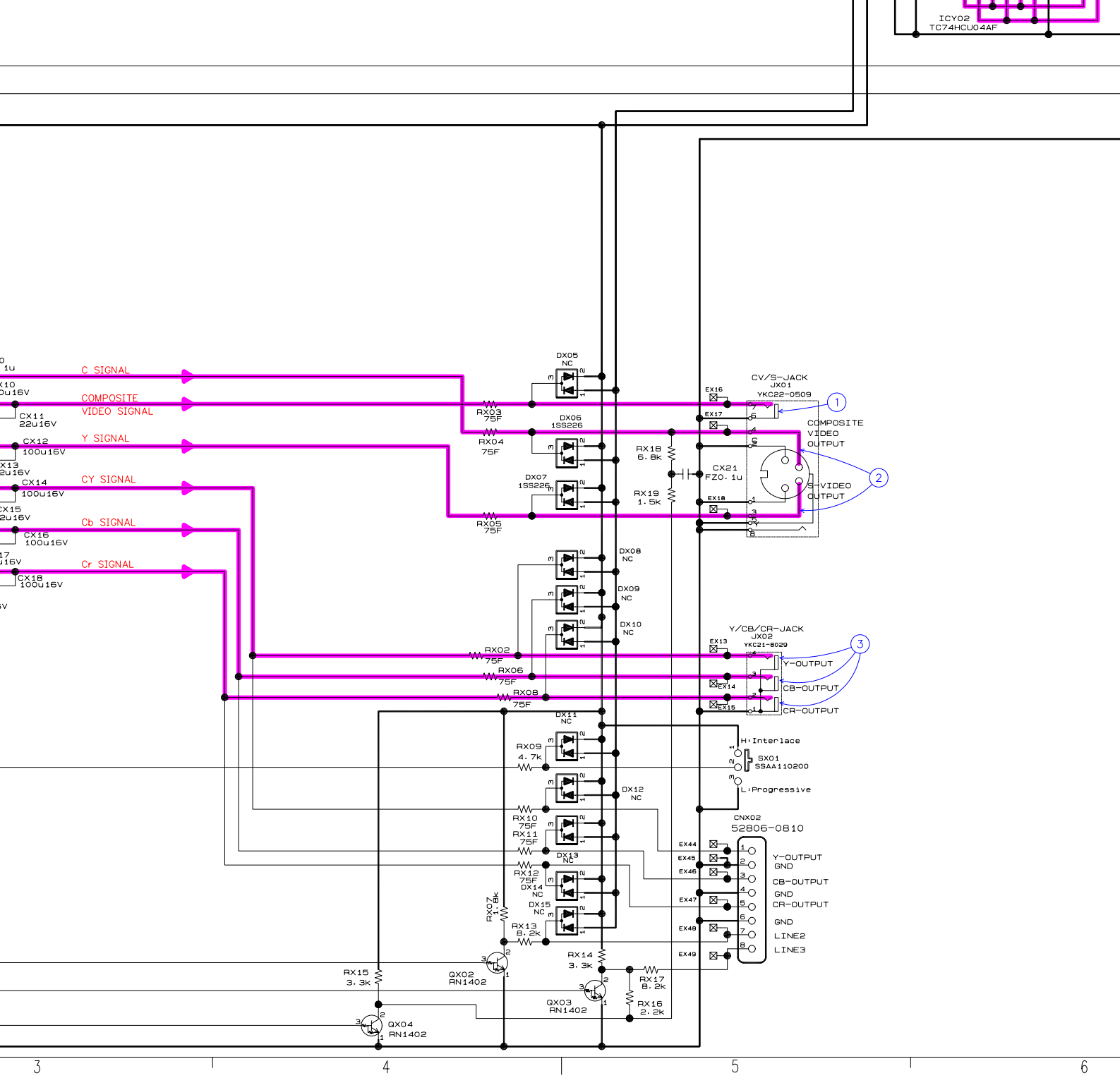

3

4

5

6

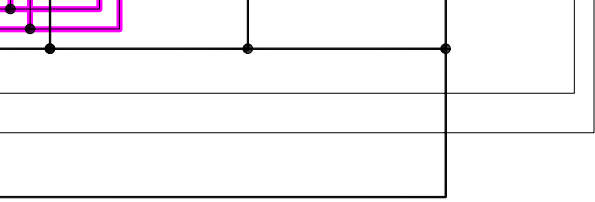

D

E

F

Fig. 3-5-6-B

6

7

8

Output Circuit Diagram - DD-8030

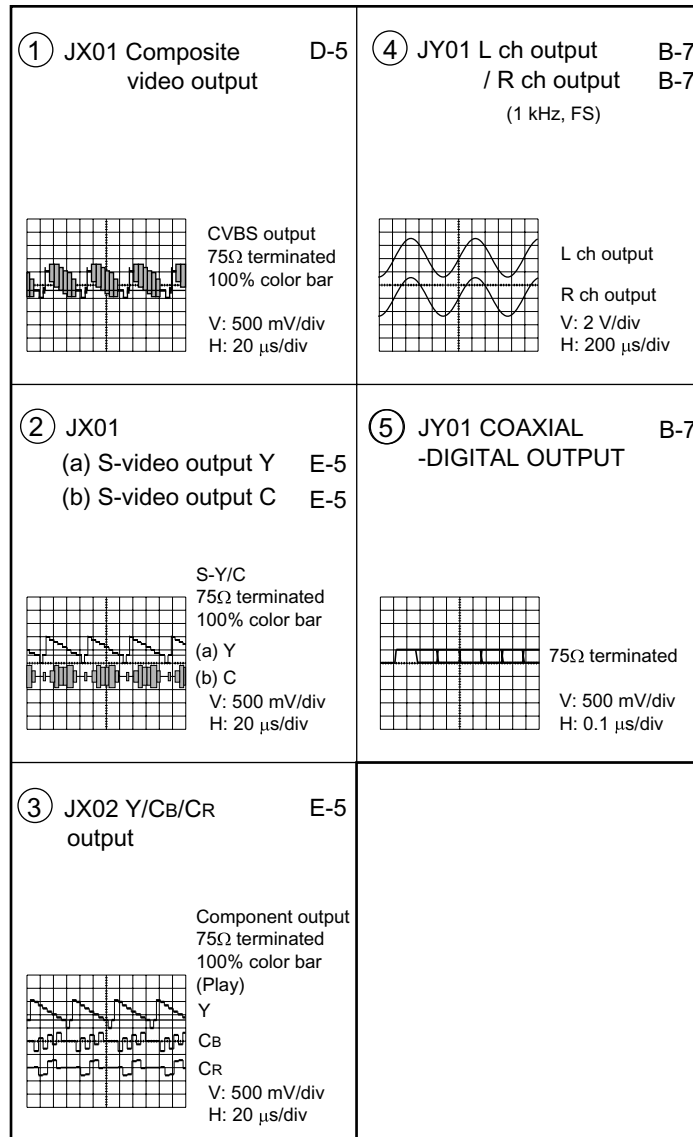

Fig. 3-3-7-B

5-5. Motor System Circuit Diagram

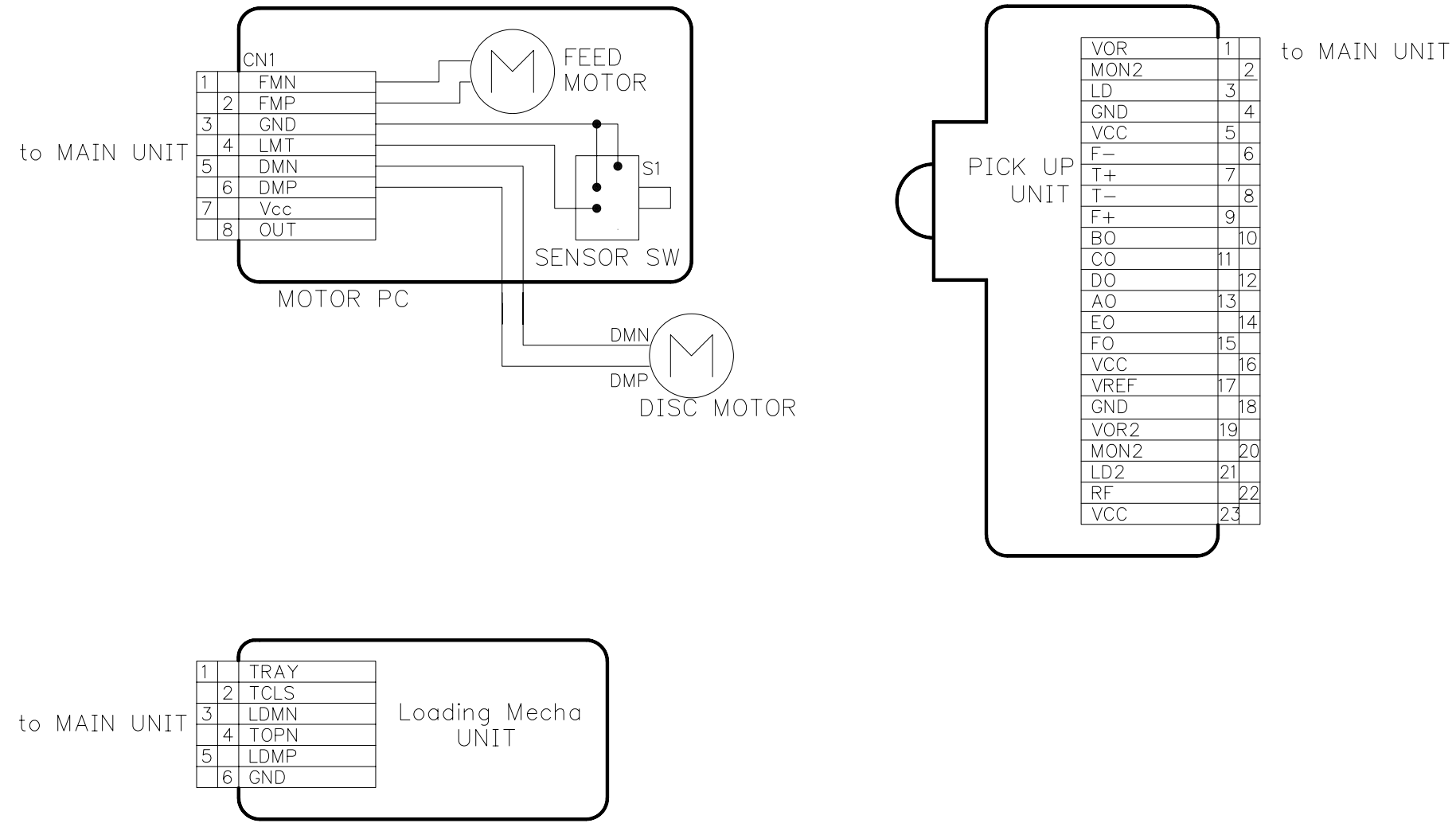
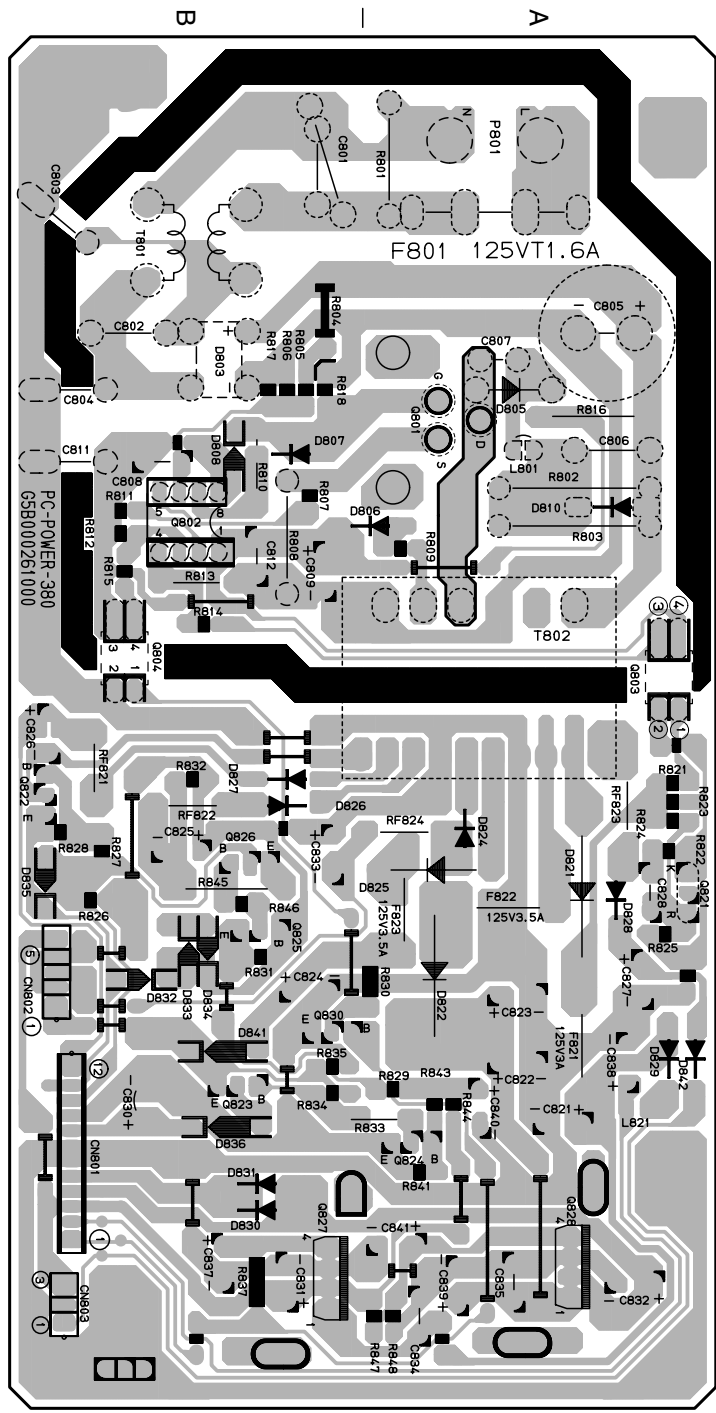

Fig. 3-5-8

6. PC BOARDS

6-1. Power Supply PC Board



Part No.	Location	Part No.	Location
C801	B1	P801	A1
C802	B2	Q801	A2
C803	B1	Q802	B2
C804	B2	Q804	B3
C805	A1	Q821	A4
C806	A2	Q822	B3
C807	A2	Q823	B4
C808	B2	Q824	A5
C809	B2	Q825	B4
C811	B2	Q826	B3
C812	B2	Q827	B5
C821	A4	Q828	A5
C822	A4	Q830	B4
C823	A4	R801	A1
C824	B4	R802	A2
C825	B3	R803	A2
C826	B3	R804	B1
C827	A4	R805	B2
C828	A4	R806	B2
C830	B4	R807	B2
C831	B5	R808	B2
C832	A5	R809	A2
C833	B3	R810	B2
C834	A5	R811	B2
C835	A5	R812	B2
C837	B5	R813	B2
C838	A4	R814	B3
C839	A5	R815	B2
C840	A4	R816	A2
C841	A5	R817	B2
CN801	B5	R818	B2
CN802	B4	R821	A3
CN803	B5	R822	A3
D803	B2	R823	A3
D805	A2	R824	A3
D806	A2	R825	A4
D807	B2	R826	B4
D808	B2	R827	B3
D810	A2	R828	B3
D821	A4	R829	A4
D822	A4	R830	A4
D824	A3	R831	B4
D825	A4	R832	B3
D826	B3	R833	A4
D827	B3	R834	B4
D828	A4	R835	B4
D829	A4	R837	B5
D830	B5	R841	A5
D831	B5	R843	A4
D832	B4	R844	A4
D833	B4	R845	B4
D834	B4	R846	B4
D835	B4	R847	A5
D836	B5	R848	A5
D841	B4	RF821	B3
D842	A4	RF822	B3
F821	A4	RF823	A3
F822	A4	RF824	A3
F823	A4	T801	B1
L801	A2	T802	A3
L821	A4		

Fig. 3-6-1 EU02 Power Supply PC Board (Bottom side)

6-3. Main PC Board

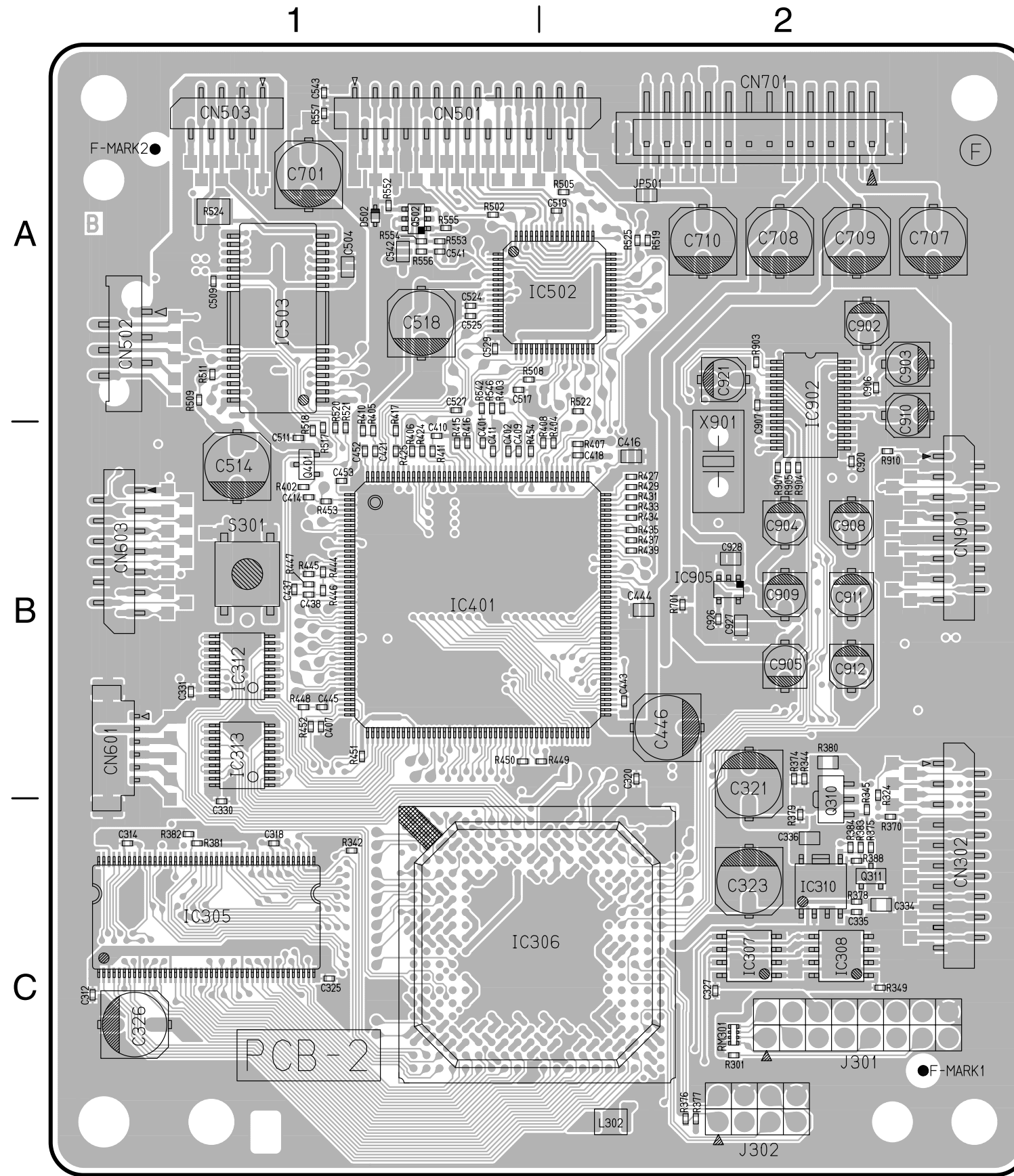

Fig. 3-6-4 EU01 Main PC Board (Top pattern and Top parts location diagram)

Main PC Board (Top Side)

Part No.	Location	Part No.	Location	Part No.	Location	Part No.	Location	Part No.	Location
C312	C1	E304	B2	E525	A1	E617	B1	R405	B1
C314	C1	E305	C2	E526	A1	E618	C1	R406	B1
C318	C1	E306	C2	E527	A1	E619	C1	R407	B2
C320	B2	E307	C2	E528	A1	E651	B1	R408	B2
C321	B2	E308	C2	E529	A1	E652	B1	R410	B1
C323	C2	E309	C2	E530	A1	E701	A2	R411	B1
C325	C1	E310	C2	E531	A1	E702	A2	R415	B1
C326	C1	E311	C2	E532	A1	E703	A2	R416	B1
C327	C2	E312	C2	E533	A2	E704	A1	R417	B1
C330	C1	E313	C2	E534	A1	E705	A2	R424	B1
C331	B1	E314	C1	E535	A2	E706	A2	R425	B1
C334	C2	E315	B2	E536	A2	E707	A2	R427	B2
C335	C2	E316	B2	E537	A1	E708	A2	R429	B2
C336	C2	E320	C2	E538	A1	E709	A2	R431	B2
C401	B1	E321	C2	E539	A1	E710	A2	R433	B2
C402	B1	E322	B1	E540	A1	E711	A2	R434	B2
C407	B1	E323	C2	E541	A1	E712	A2	R435	B2
C409	B1	E324	C2	E542	A1	E713	A2	R437	B2
C410	B1	E325	C2	E543	A1	E714	A2	R439	B2
C411	B1	E326	C1	E544	A1	E715	A2	R444	B1
C414	B1	E327	C1	E545	A2	E901	B2	R445	B1
C416	B2	E328	C1	E546	A1	E902	B2	R446	B1
C418	B2	E329	C1	E547	A1	E903	B2	R447	B1
C421	B1	E330	C1	E548	A2	E904	B2	R448	B1
C437	B1	E331	C2	E549	A1	E905	B2	R449	B2
C438	B1	E332	B1	E550	A1	E906	B2	R450	B1
C443	B2	E333	C1	E551	A1	E907	B2	R451	B1
C444	B2	E334	C1	E552	A1	E908	B2	R452	B1
C445	B1	E335	C1	E553	A1	E909	B2	R453	B1
C446	B2	E336	C1	E554	A1	E910	B2	R454	B1
C452	B1	E337	C1	E555	A1	E911	B2	R502	A1
C453	B1	E401	B2	E556	A1	E912	B2	R505	A2
C504	A1	E402	B1	E557	A1	E913	B2	R508	A1
C509	A1	E403	A1	E558	A1	E914	B2	R509	A1
C511	B1	E405	B1	E559	A1	E915	B2	R511	A1
C514	B1	E406	B1	E560	A1	F-MARK1	C2	R517	B1
C517	A1	E407	B1	E561	A2	F-MARK2	A1	R518	B1
C518	A1	E408	B2	E562	A2	IC305	C1	R519	A2
C519	A2	E409	B2	E563	A2	IC306	C1	R520	B1
C524	A1	E410	B1	E564	A2	IC307	C2	R521	B1
C525	A1	E411	B2	E565	A2	IC308	C2	R522	A2
C527	A1	E412	B2	E566	A2	IC310	C2	R524	A1
C529	A1	E413	B1	E567	A2	IC312	B1	R525	A2
C541	A1	E414	B1	E568	A2	IC313	B1	R542	A1
C542	A1	E415	B1	E569	A2	IC401	B1	R546	A1
C543	A1	E416	B1	E570	A2	IC502	A2	R552	A1
C701	A1	E417	B1	E571	A2	IC503	A1	R553	A1
C707	A2	E418	B1	E572	A2	IC902	A2	R554	A1
C708	A2	E419	B1	E573	A2	IC905	B2	R555	A1
C709	A2	E420	B1	E574	A2	J301	C2	R556	A1
C710	A2	E421	B1	E575	A2	J302	C2	R557	A1
C902	A2	E422	B1	E576	A2	JP301	B2	R701	B2
C903	A2	E423	B1	E577	A2	JP501	A2	R903	A2
C904	B2	E424	B1	E578	A2	L302	C2	R904	B2
C905	B2	E425	B1	E579	A1	Q310	C2	R905	B2
C906	A2	E426	B1	E580	A1	Q311	C2	R907	B2
C907	A2	E501	A1	E581	A1	Q401	B1	R910	B2
C908	B2	E502	A1	E582	A1	Q502	A1	RM301	C2
C909	B2	E503	A1	E583	A2	R301	C2	S301	B1
C910	A2	E504	A1	E584	A1	R324	B2	TP401	B1
C911	B2	E505	A2	E585	A1	R342	C1	TP402	B1
C912	B2	E506	A2	E586	A1	R344	B2	TP403	B2
C920	B2	E507	A1	E587	A1	R345	C2	TP404	B2
C921	A2	E508	A1	E588	A1	R349	C2	TP405	B1
C926	B2	E509	A1	E589	A1	R370	C2	TP406	B1
C927	B2	E510	A1	E601	B1	R374	B2	TP407	B2
C928	B2	E511	A1	E602	B1	R375	C2	TP408	B1
CN302	C2	E512	A1	E603	B1	R376	C2	TP409	B2
CN501	A1	E513	A1	E604	B1	R377	C2	TP410	B1
CN502	A1	E514	A1	E605	B1	R378	C2	TP411	B1
CN503	A1	E515	A1	E606	B1	R379	C2	TP412	B1
CN601	B1	E516	A1	E608	B1	R380	B2	TP413	B1
CN603	B1	E517	A1	E609	B1	R381	C1	TP414	B1
CN701	A2	E518	A1	E610	B1	R382	C1	TP501	B1
CN901	B2	E519	A2	E611	B1	R383	C2	TP502	A2
D502	A1	E520	A2	E612	B1	R384	C2	TP503	B1
E201	B2	E521	A2	E613	B1	R388	C2	TP504	B1
E301	B2	E522	A1	E614	B1	R402	B1	X901	B2
E302	B2	E523	A1	E615	B1	R403	A1		
E303	B2	E524	A1	E616	C1	R404	B2		

Main PC Board (Bottom Side)

Part No.	Location	Part No.	Location	Part No.	Location	Part No.	Location
C301	C1	C523	A1	R311	C2	R430	B1
C302	C2	C526	A1	R312	C2	R432	B1
C303	C1	C528	A1	R313	C1	R436	B1
C304	C2	C530	A2	R314	C2	R438	B1
C305	B2	C532	A1	R315	C2	R442	B1
C306	B2	C533	A1	R316	C2	R443	B1
C307	C1	C534	A2	R317	C2	R455	B2
C308	C1	C539	A2	R318	C2	R461	B2
C309	C2	C601	B2	R319	C1	R501	A2
C310	C2	C602	B2	R320	C1	R503	A2
C311	C1	C603	B2	R321	C1	R504	A2
C313	C2	C702	A1	R322	C1	R506	A1
C315	C2	C703	A1	R323	C1	R507	A1
C316	C2	C704	A1	R325	C1	R510	A1
C317	C2	C705	A1	R326	B1	R512	A1
C319	C1	C706	A1	R327	C1	R513	B2
C322	C1	C711	A1	R328	C1	R514	A2
C324	C1	C712	A1	R329	C1	R515	A2
C328	C1	C713	A1	R330	C1	R516	A2
C329	C1	C714	A1	R331	C1	R523	A2
C332	B2	C715	A1	R332	C1	R526	A2
C333	C2	C901	B1	R333	C1	R527	A2
C337	C1	C913	A1	R334	C1	R528	A2
C403	B2	C914	A1	R335	C1	R529	A2
C404	B2	C915	B1	R336	C1	R530	A2
C405	B2	C916	B1	R337	C1	R531	A2
C406	B2	C917	B1	R338	C1	R532	A2
C408	B2	C918	B1	R339	C1	R533	A2
C412	B2	C919	B1	R340	B2	R534	A2
C413	B2	C922	B1	R341	C1	R535	A1
C415	B2	C923	B1	R343	C2	R536	A1
C417	A2	C924	B1	R346	C2	R537	A2
C419	B1	C925	B1	R347	C2	R538	A2
C420	B2	D501	A1	R348	C2	R539	A1
C422	B1	D901	B1	R350	C2	R540	A2
C423	B2	D902	B1	R351	C1	R541	A2
C424	B1	D903	B1	R352	B1	R545	A1
C425	B1	F-MARK3	C1	R353	B1	R547	A2
C426	B1	F-MARK4	A2	R354	C1	R551	A2
C427	B1	IC301	B2	R355	C1	R601	B2
C428	B1	IC302	B2	R356	C1	R602	B2
C429	B1	IC303	B2	R357	C2	R603	B2
C430	B1	IC304	B2	R358	C2	R604	B2
C431	B1	IC309	B2	R359	C1	R605	B2
C432	B1	IC402	B2	R360	C1	R606	B2
C433	B1	IC501	A2	R361	C2	R607	B2
C434	B1	IC504	A2	R362	C2	R608	B2
C435	B1	IC901	B1	R363	C2	R609	B2
C436	B2	IC903	B1	R364	C2	R610	B2
C439	B1	IC904	B1	R365	C2	R615	B2
C440	B1	Q301	C1	R366	C1	R616	B2
C441	B2	Q302	C1	R367	C1	R702	A1
C442	B1	Q303	C1	R368	C1	R901	B1
C447	B2	Q304	C1	R369	C1	R906	B1
C448	B1	Q305	C1	R371	C1	R908	B1
C449	B2	Q306	C1	R372	C1	R909	B1
C450	B2	Q307	C2	R373	B1	R911	B1
C451	B2	Q308	C1	R385	A1	R912	B1
C501	A2	Q309	C1	R386	A1	R913	B1
C502	A2	Q501	A1	R387	A1	R914	B1
C503	A2	Q503	B2	R401	A2	R915	B1
C505	A2	Q504	A2	R409	B2	R916	B1
C506	A2	Q505	A2	R412	B1	R917	B1
C507	A2	Q506	A2	R413	B2	R918	B1
C508	A1	R302	C2	R414	B2	R919	B1
C510	A1	R303	C1	R418	B1	RM302	C2
C512	B2	R304	C2	R419	B2	RM303	C2
C513	A1	R305	C2	R420	B2	RM304	C2
C515	A2	R306	C1	R421	B2	RM305	C2
C516	A2	R307	B2	R422	B2	RM306	C2
C520	A2	R308	B2	R423	B2	RM307	C2
C521	A2	R309	C2	R426	B1	RM308	C2
C522	A1	R310	C1	R428	B1	RM309	C2
						RM310	C2

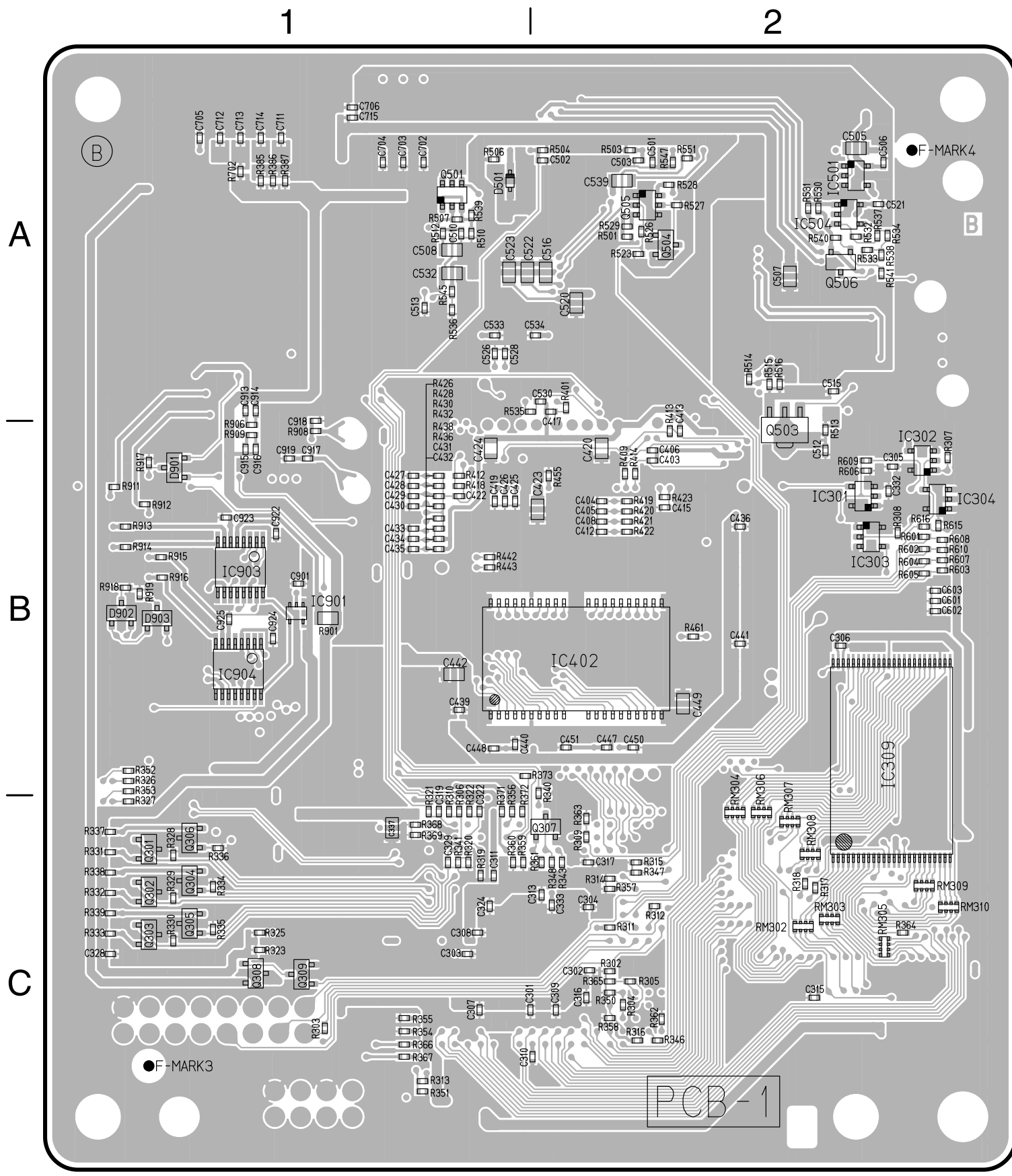

Fig. 3-6-5 EU01 Main PC Board (Bottom pattern and bottom parts location diagram)

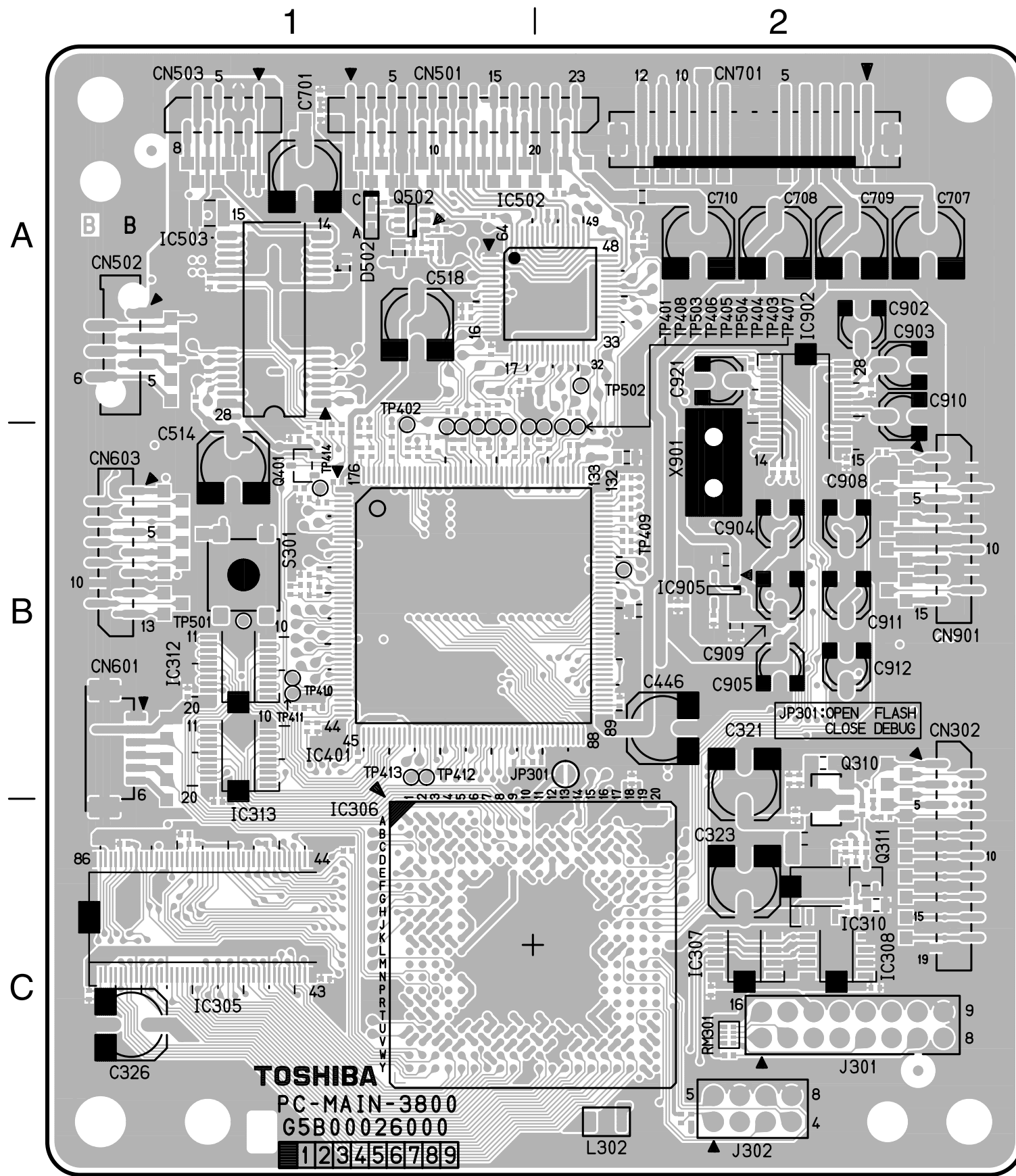

Fig. 3-6-6 EU01 Main PC Board (Top pattern, character/symbol)

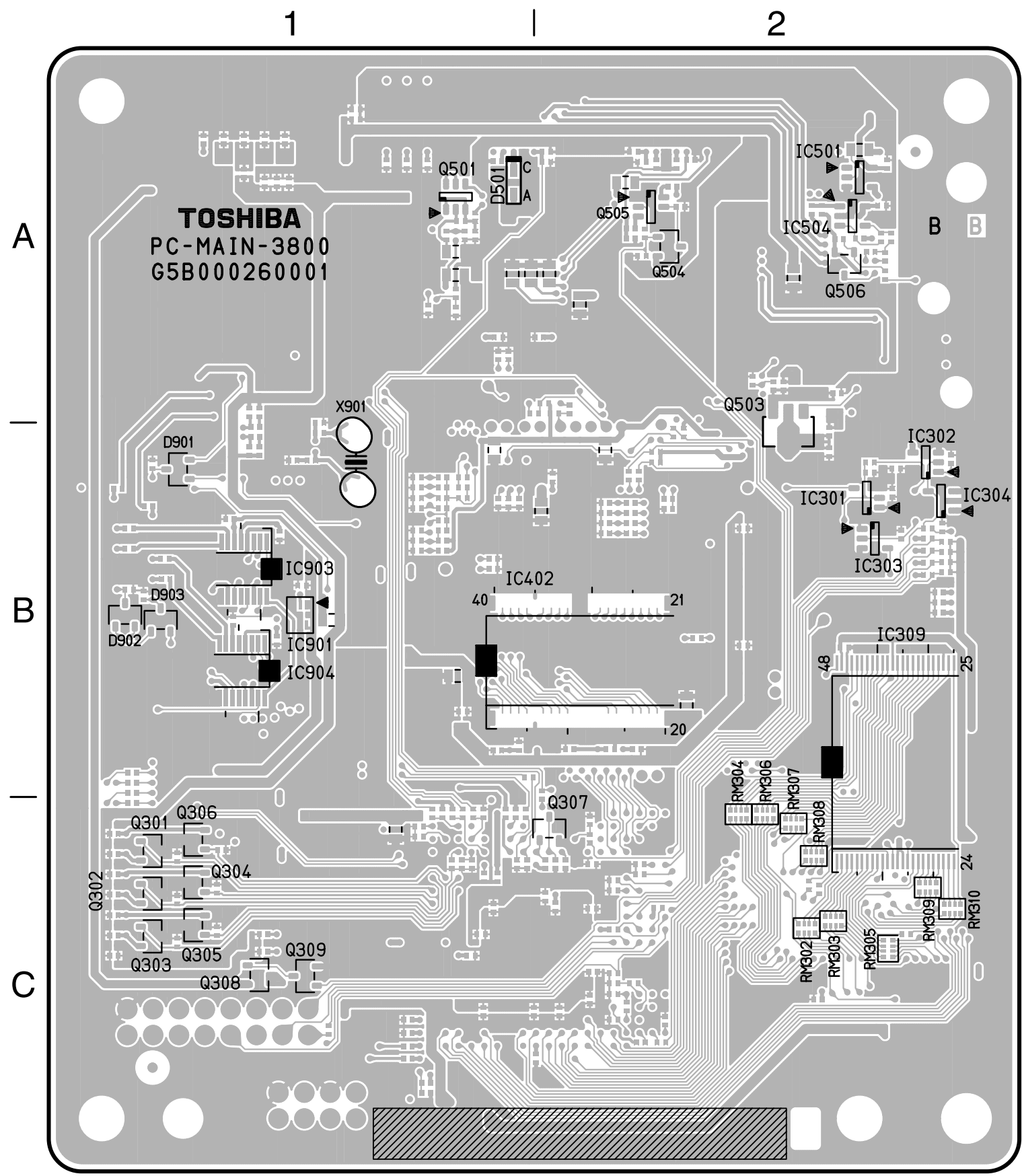

Fig. 3-6-7 EU01 Main PC Board (Bottom pattern, character/symbol)

6-4. (A) Output PC Board - DD-6030

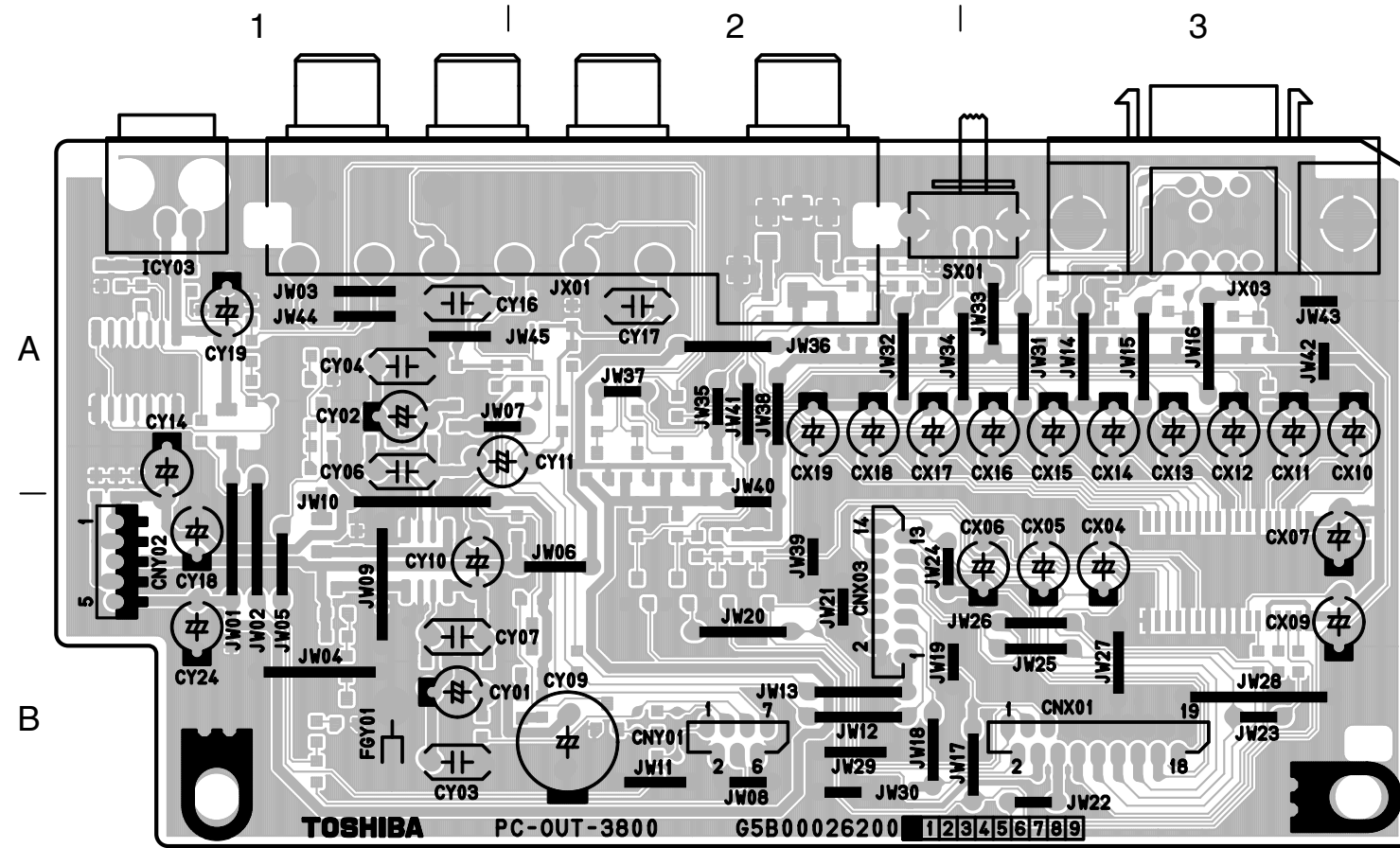

Fig. 3-6-8-A EU05 Output PC Board (Top side)

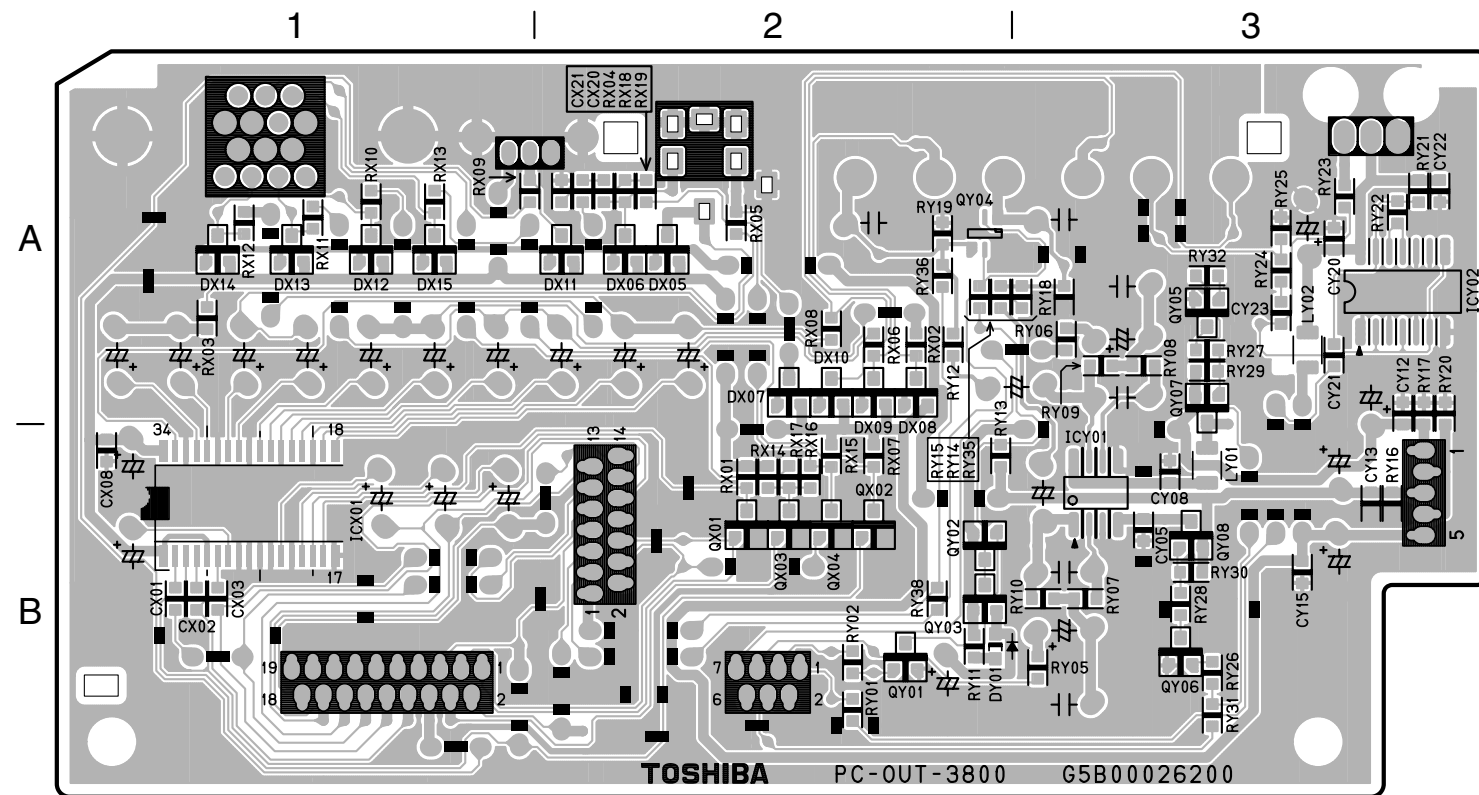

Fig. 3-6-9-B EU05 Output PC Board (Bottom side)

Part No.	Location	Part No.	Location
CNX01	B3	JW07	A1
CNX03	B2	JW08	B2
CNY01	B2	JW09	B1
CNY02	B1	JW10	B1
CX04	B3	JW11	B2
CX05	B3	JW12	B2
CX06	B3	JW13	B2
CX07	B3	JW14	A3
CX09	B3	JW15	A3
CX10	A3	JW16	A3
CX11	A3	JW17	B2
CX12	A3	JW18	B2
CX13	A3	JW19	B2
CX14	A3	JW20	B2
CX15	A3	JW21	B2
CX16	A3	JW22	B3
CX17	A2	JW23	B3
CX18	A2	JW24	B2
CX19	A2	JW25	B3
CY01	B1	JW26	B3
CY02	A1	JW27	B3
CY03	B1	JW28	B3
CY04	A1	JW29	B2
CY06	A1	JW30	B2
CY07	B1	JW31	A3
CY09	B2	JW32	A2
CY10	B1	JW33	A3
CY11	A2	JW34	A2
CY14	A1	JW35	A2
CY16	A2	JW36	A2
CY17	A2	JW37	A2
CY18	B1	JW38	A2
CY19	A1	JW39	B2
CY24	B1	JW40	A2
FGY01	B1	JW41	A2
ICY03	A1	JW42	A3
JW01	B1	JW43	A3
JW02	B1	JW44	A1
JW03	A1	JW45	A2
JW04	B1	JX01	A2
JW05	B1	JX03	A3
JW06	B2	SX01	A2

Part No.	Location	Part No.	Location	Part No.	Location
CX01	B1	QX01	B2	RY02	B2
CX02	B1	QX02	B2	RY05	B3
CX03	B1	QX03	B2	RY06	A3
CX08	B1	QX04	B2	RY07	B3
CX20	A2	QY01	B2	RY08	A3
CX21	A2	QY02	B2	RY09	A3
CY05	B3	QY03	B2	RY10	B3
CY08	B3	QY04	A2	RY11	B2
CY12	A3	QY05	A3	RY12	A2
CY13	B3	QY06	B3	RY13	B2
CY15	B3	QY07	A3	RY14	A2
CY20	A3	QY08	B3	RY15	A2
CY21	A3	RX01	B2	RY16	B3
CY22	A3	RX02	A2	RY17	A3
CY23	A3	RX03	A1	RY18	A3
DX05	A2	RX04	A2	RY19	A2
DX06	A2	RX05	A2	RY20	A3
DX07	A2	RX06	A2	RY21	A3
DX08	A2	RX07	B2	RY22	A3
DX09	A2	RX08	A2	RY23	A3
DX10	A2	RX09	A1	RY24	A3
DX11	A2	RX10	A1	RY25	A3
DX12	A1	RX11	A1	RY26	B3
DX13	A1	RX12	A1	RY27	A3
DX14	A1	RX13	A1	RY28	B3
DX15	A1	RX14	B2	RY29	A3
DY01	B2	RX15	B2	RY30	B3
ICX01	B1	RX16	B2	RY31	B3
ICY01	B3	RX17	B2	RY32	A3
ICY02	A3	RX18	A2	RY35	A3
LY01	B3	RX19	A2	RY36	A2
LY02	A3	RY01	B2	RY38	B2

6-4. (B) Output PC Board - DD-8030

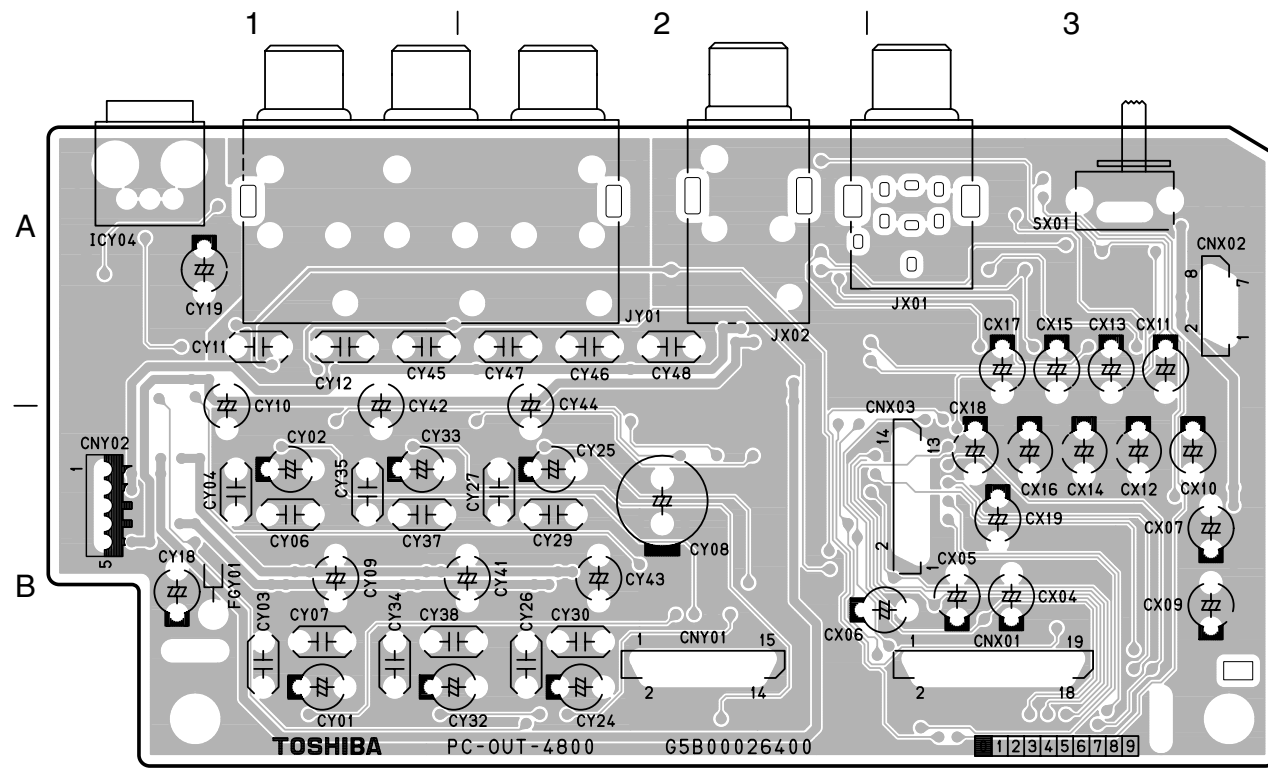

Fig. 3-6-8-B EU05 Output PC Board (Top side)

Part No.	Location	Part No.	Location
CNX01	B3	CY12	A1
CNX02	A3	CY18	B1
CNX03	B3	CY19	A1
CNY01	B2	CY24	B2
CNY02	B1	CY25	B2
CX04	B3	CY26	B2
CX05	B3	CY27	B2
CX06	B3	CY29	B2
CX07	B3	CY30	B2
CX09	B3	CY32	B1
CX10	B3	CY33	B1
CX11	A3	CY34	B1
CX12	B3	CY35	B1
CX13	A3	CY37	B1
CX14	B3	CY38	B1
CX15	A3	CY41	B2
CX16	B3	CY42	B1
CX17	A3	CY43	B2
CX18	B3	CY44	A2
CX19	B3	CY45	A1
CY01	B1	CY46	A2
CY02	B1	CY47	A2
CY03	B1	CY48	A2
CY04	B1	FGY01	B1
CY06	B1	ICY04	A1
CY07	B1	JX01	A3
CY08	B2	JX02	A2
CY09	B1	JY01	A1
CY10	B1	SX01	A3
CY11	A1		

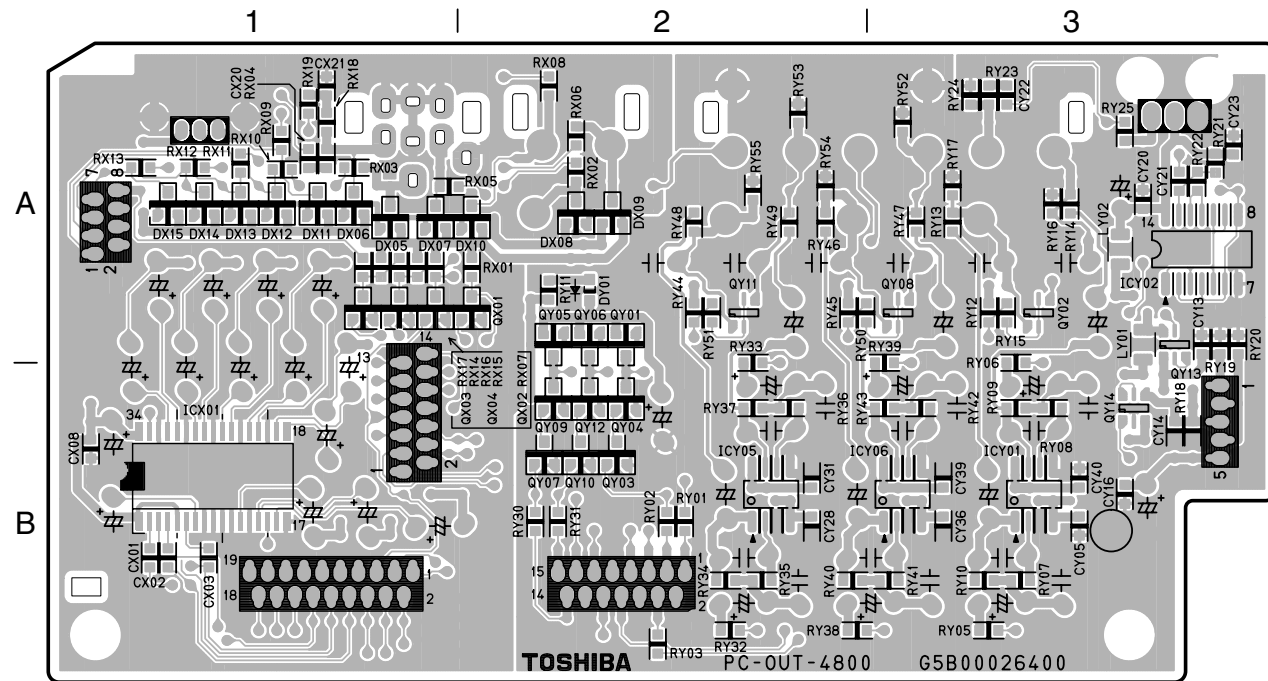

Fig. 3-6-9-B EU05 Output PC Board (Bottom side)

Part No.	Location	Part No.	Location	Part No.	Location
CX01	B1	QY01	A2	RY11	A2
CX02	B1	QY02	A3	RY12	A3
CX03	B1	QY03	B2	RY13	A3
CX08	B1	QY04	B2	RY14	A3
CX20	A1	QY05	A2	RY15	A3
CX21	A1	QY06	A2	RY16	A3
CY05	B3	QY07	B2	RY17	A3
CY13	A3	QY08	A3	RY18	B3
CY14	B3	QY09	B2	RY19	A3
CY16	B3	QY10	B2	RY20	A3
CY20	A3	QY11	A2	RY21	A3
CY21	A3	QY12	B2	RY22	A3
CY22	A3	QY13	A3	RY23	A3
CY23	A3	QY14	B3	RY24	A3
CY28	B2	RX01	A2	RY25	A3
CY31	B2	RX02	A2	RY30	B2
CY36	B3	RX03	A1	RY31	B2
CY39	B3	RX04	A1	RY32	B2
CY40	B3	RX05	A1	RY33	A2
DX05	A1	RX06	A2	RY34	B2
DX06	A1	RX07	A1	RY35	B2
DX07	A1	RX08	A2	RY36	B2
DX08	A2	RX09	A1	RY37	B2
DX09	A2	RX10	A1	RY38	B2
DX10	A2	RX11	A1	RY39	A3
DX11	A1	RX12	A1	RY40	B2
DX12	A1	RX13	A1	RY41	B3
DX13	A1	RX14	A1	RY42	B3
DX14	A1	RX15	A1	RY43	B3
DX15	A1	RX16	A1	RY44	A2
DY01	A2	RX17	A1	RY45	A2
ICX01	B1	RX18	A1	RY46	A2
ICY01	B3	RX19	A1	RY47	A3
ICY02	A3	RY01	B2	RY48	A2
ICY05	B2	RY02	B2	RY49	A2
ICY06	B3	RY03	B2	RY50	A2
LY01	A3	RY05	B3	RY51	A2
LY02	A3	RY06	A3	RY52	A3
QX01	A2	RY07	B3	RY53	A2
QX02	A1	RY08	B3	RY54	A2
QX03	A1	RY09	B3	RY55	A2
QX04	A1	RY10	B3		

SECTION 4 PARTS LIST

SAFETY PRECAUTION

The parts identified by ! (Δ) mark are critical for safety. Replace only with part number specified.

The mounting position of replacement is to be identical with originals.

The substitute replacement parts which do not have the same safety characteristics as specified in the parts list may create shock, fire or other hazards.

NOTICE

The part number must be used when ordering parts in order to assist in processing, be sure to include the model number and description.

ABBREVIATIONS

1. Integrated Circuit (IC)

2. Capacitor (Cap)

- Capacitance Tolerance (for Nominal Capacitance more than 10pF)

Table 4-2-1

Symbol	B	C	D	F	G	J	K	M	N
Tolerance %	± 0.1	± 0.25	± 0.5	± 1	± 2	± 5	± 10	± 20	± 30

Symbol	P	Q	T	U	V	W	X	Y	Z
Tolerance %	+ 100 0	+ 30 - 10	+ 50 - 10	+ 75 - 10	+ 20 - 10	+ 100 - 10	+ 40 - 20	+ 150 - 10	+ 80 - 20

Ex. 10MF J = 10 μ F ± 5%

- Capacitance Tolerance (for Nominal Capacitance 10pF or less)

Table 4-2-2

Symbol	B	C	D	F	G
Tolerance pF	± 0.1	± 0.25	± 0.5	± 1	± 2

Ex. 10pF G = 10pF ± 2pF

3. Resistor (Res)

- Resistance tolerance

Table 4-3-1

Symbol	B	C	D	F	G	J	K	M
Tolerance %	± 0.1	± 0.25	± 0.5	± 1	± 2	± 5	± 10	± 20

Ex. 470ohmJ = 470ohm± 5%

4. EXPLODED VIEWS

4-1. Chassis Assembly (Type A)

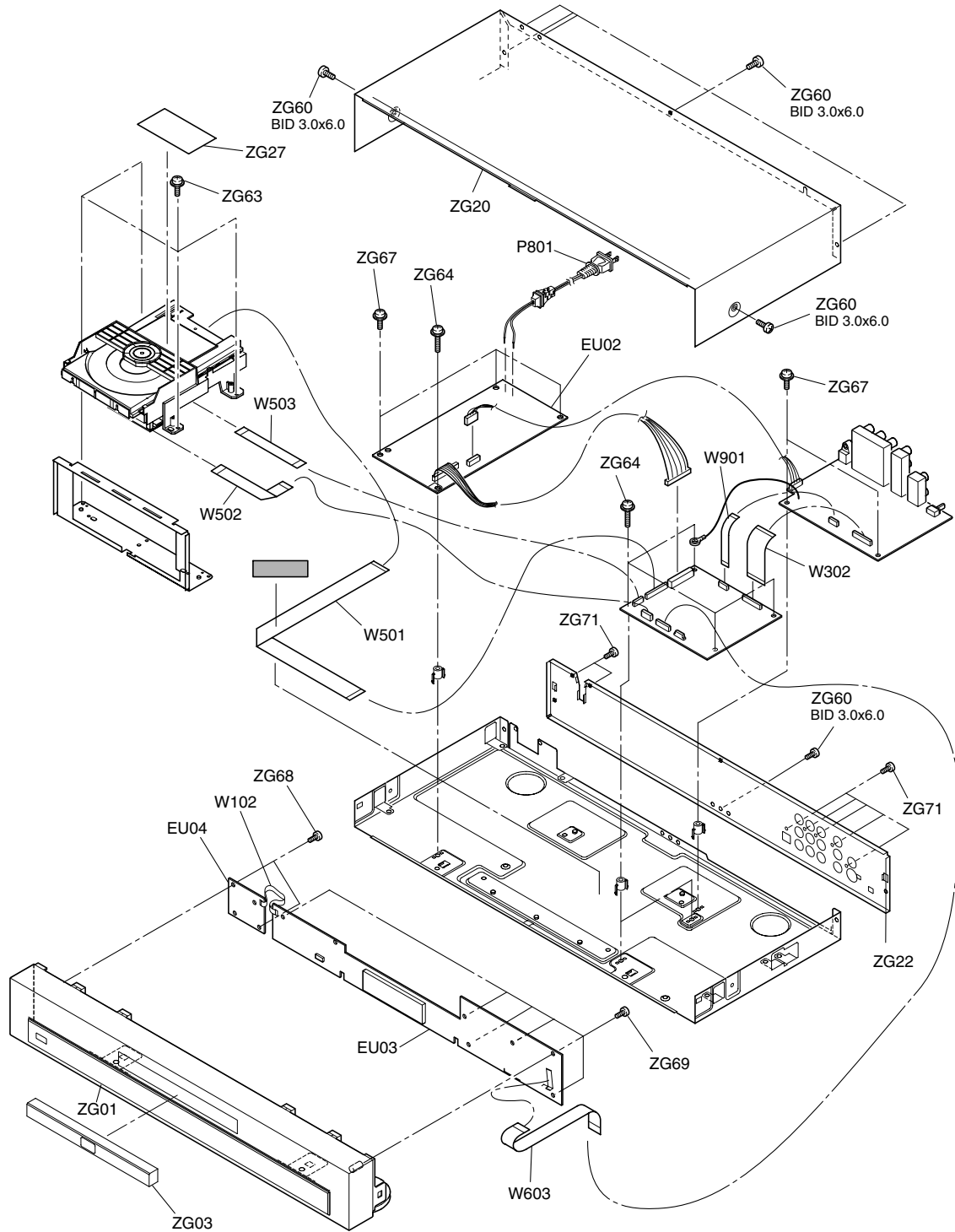

Fig. 4-4-1

4-2. Chassis Assembly (Type B)

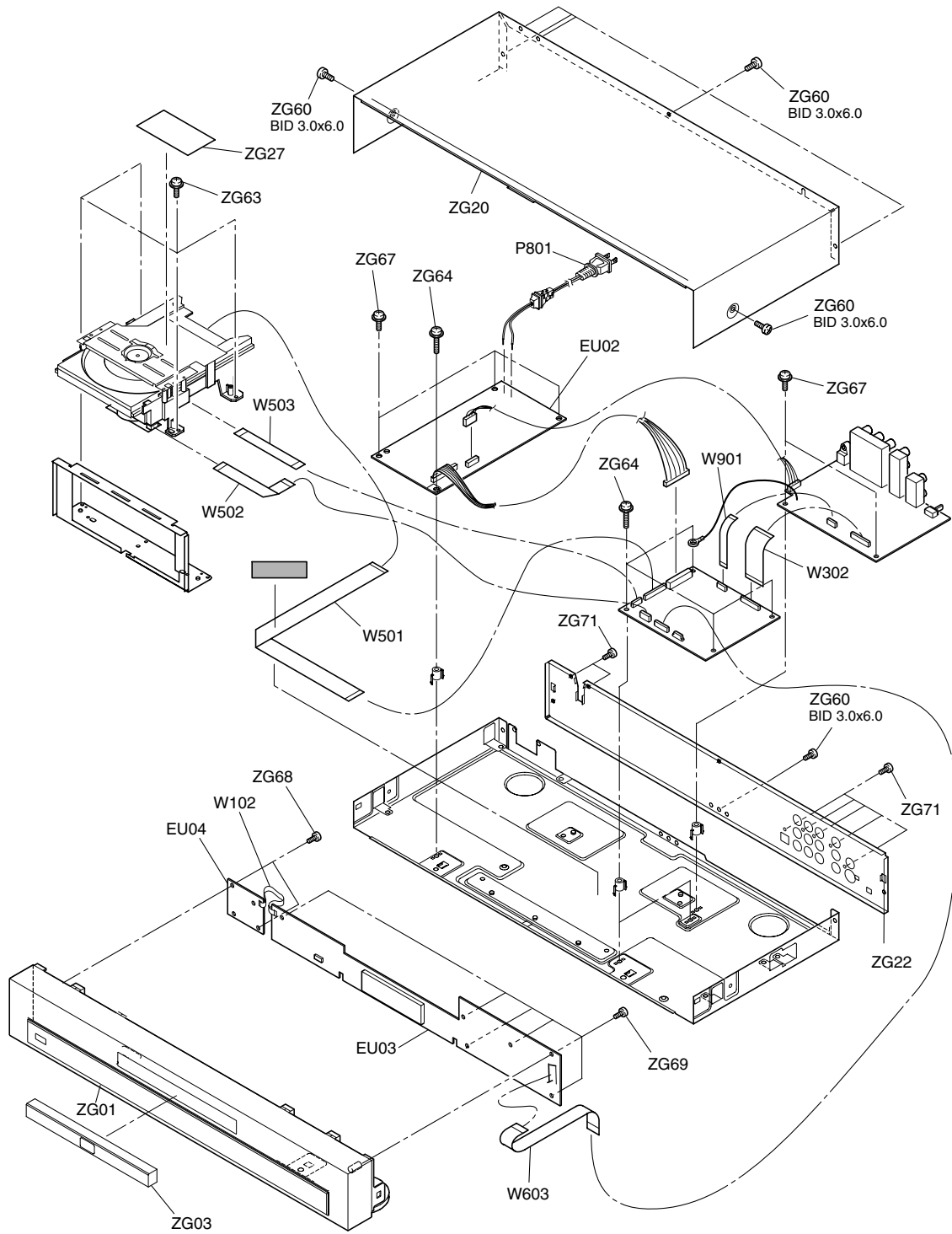

Fig. 4-4-2

5. PARTS LIST

DD-8030 PARTS	
Part Number	Description
I/B DD8030	I/B DD8030
79010026	TRANSF-(SRW3020ED5-210)
79050041	COUPLER-PHOTO (TLP621)
79060092	LED (RED EL31051VRT)
79070499	MECHA-P/U ASSY
79073095	COVER-TOP (BLACK)
79077235	MANUAL, VIEWER JPEG
79080184	CABLE (FLEXIBLE 19P-L70)
79080192	CABLE (6 pin main-chassis mech)
79080273	CABLE
79080299	CABLE (FLEXIBLE 8P-L115)
79080300	CABLE (FLEXIBLE 13P-L130)
79085104	PCB-POWER ASSY (AC120V)
79088028	CORD-POWER UL
79089156	BUZZER (PKM13EPY)
79089158	SWITCH-SLD-SSAA110200
79089160	JACK-VIDEO (1CH,YELLOW+S-VIDEO)
79089167	DISPLAY FL (8-BT-230GNK)
79085106	PCB-OUTPUT
P000354950	PCB-FRONT
P000354960	PCB-POWER-SW
79100009	PCB-MAIN
79100013	PANEL-FRONT BLACK (DD-8030)
79100015	PANEL-TRAY BLACK (DD-8030)
79100017	REMOTE