

DOUBLE MODULOMETER

Reason:

Monitoring both channels using 2 needles instead of 1 needle.

Important:

This modification is very critical to execute as we are working with extremely fragile open instrument meters. It is recommended to execute this modification only at the factory. The new software version eprom V2.10 or higher is needed

Modulometer kit P/N 7131 114 000

Parts:	Description	Qty
0119 155 034	Modulometer green	1 (Needle end must be painted in green.)
3001 023 236	Screw M2x16	2
3321 002 034	Shim M2	4
3201 002 036	Nut M2	6
0131 114 001	Window	1
0131 114 002	Motor cover	1
9131 325 000	Pcb	1
8131 404 000	Wiring double meter	1

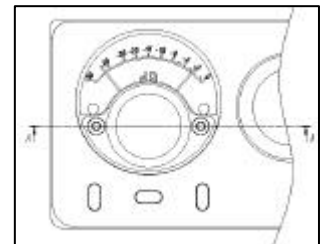

Old modulometer needle must be painted red.

Procedure:

- 1 window
- 2 motor housing
- 3 modulo (Green)
- 4 screw M2x16
- 5 nut M2
- 6 elastic shim
- 7 wiring
- 8 PCB
- A nut (pan)
- B nut M2
- C nut M2

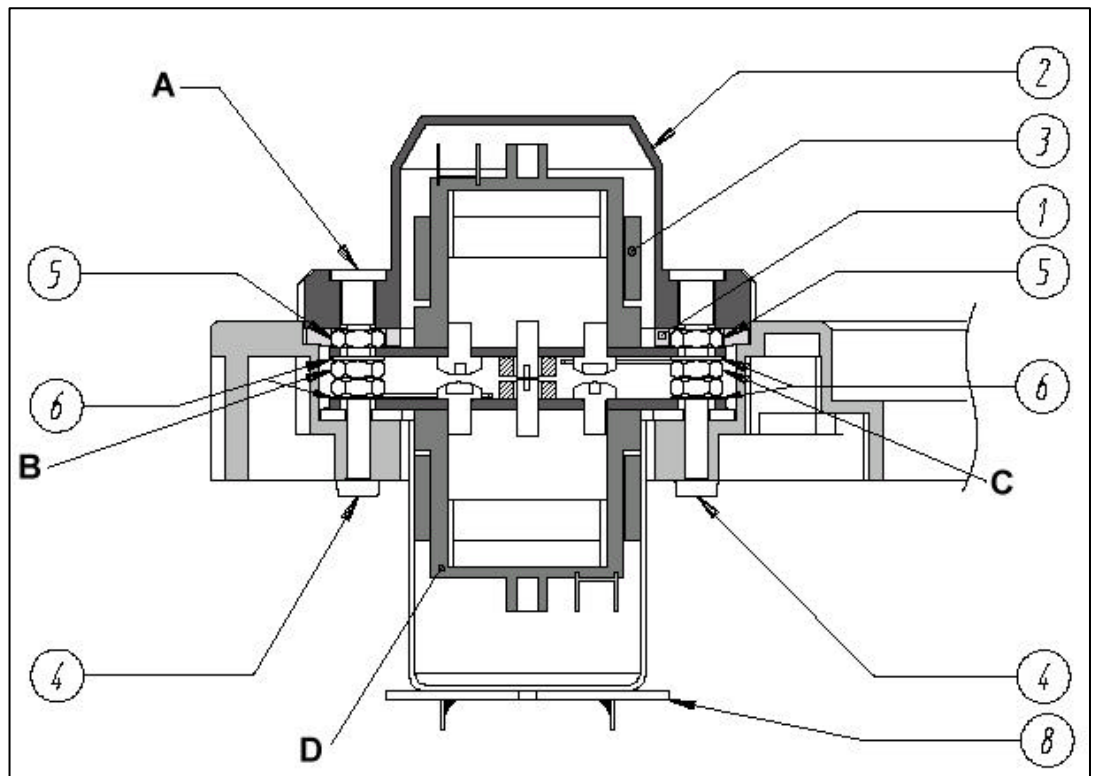

Remove the keyboard from the Nagra-V:

Disconnect the ribbon cables as well as the potentiometer connections. Remove the 2 screws from the bottom as well as the 4 nuts on the left and right sides.

Remove the keyboard PCB:

Disconnect the brown flex from the main switch. Disconnect the modulometer. Remove the 7 screws.

Remove the old modulometer:

Remove the 2 nuts (A) from the modulometer window, remove the window and remove the 2 nuts. Carefully take out the modulometer and unsolder the white and red-white wire. Remove from the rear of the keyboard the 2 screws (No 4) and replace them by the 2 longer screws M2x16. Paint the needle end red.

Installing the red modulo meter (D):

Before installation, by using a soldering iron, make a small groove along the black plastic housing of the red modulometer. See picture. The groove sits on the lower part of the housing. See white arrow.

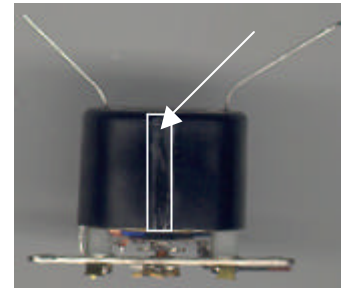

The groove must be large enough to pass a wire. Carefully insert the red modulometer and lock it by using 2 elastic shims (No 6) and 2 nuts (No 5).

Verify over the full scale that the needle does not touch the housing.

Adjust the mechanical position of the needle versus the scale so that it sits on the small line on the left side of -40 dB.

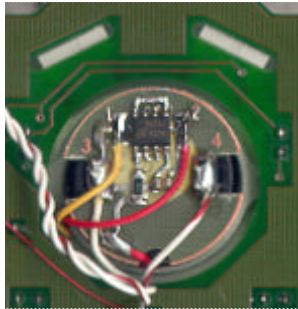

On the rear side of the red modulometer, solder the PCB. See picture.

From the rear side, insert a red-white wire (60 mm) in the groove of the red modulometer. Solder the red-white wire on the PCB position E5. Solder the previously removed wiring on the added PCB (E3 is white, E4 is red-white)

Installing the green modulometer (No 3):

Carefully remove the black plastic housing (cutter or solder set) and cut the 2 solder lips at the base. Paint the needle end green. Add on the M2x16 screws 2 nuts (B & C) and leave

a space between these nuts and the nuts locking the red modulometer. The space between the 2 coils must be approx 0.4 to 0.8 mm (See arrow F).

Add the 2 elastic shims (No 6) and carefully install the green modulometer and lock it by adding the 2 nuts (No 5).

Verify over the full scale that the needle is not touching the housing or the

red needle. If it does, the needle end must be cut.

Solder the white wire to the + of the green modulometer (see arrow E).

Adjust the mechanical position of the needle versus the scale so that it sits on the small line corresponding to 0 dB.

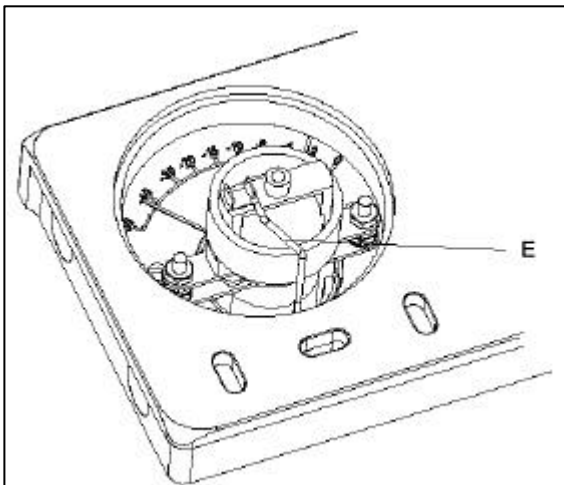
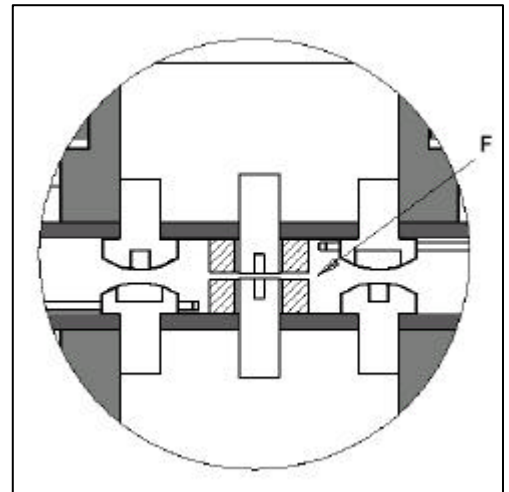

Insert the window (No 1) and verify that the modulometer assembly is not touching it (see arrow G). Add the motor housing (No 2). Lock the assembly with the 2 nuts (see arrow A).

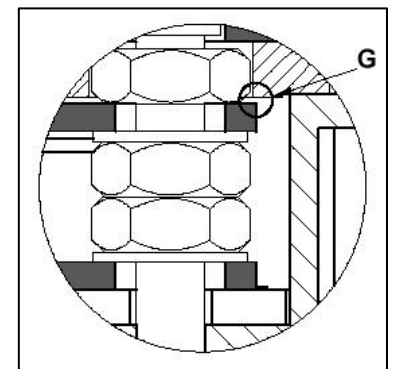

Solder the white and the red-white wire on the lips of the red modulometer. From the added PCB, solder a yellow wire on position E1 and a red wire on position E2. Solder the yellow wire on pin 18 U3 and the red wire on pin 19 U3 from the keyboard PCB.

The 2 needles are at opposite ends of the scale.

Reassemble the keyboard PCB on the keyboard. Install the keyboard back on the Nagra-V and connect all the ribbon cables. Connect the small connector from the red modulometer back to J1 on the keyboard PCB. Connect the brown flex from the main switch back to the keyboard.

Hardware options:

By using NV-com, for the double modulometer, select the fourth hardware option position.

Electrical adjustment:

If NV-com (> V1.00) is not available use the Nadcom software. Connect the Nagra-V via the RS 232/422 adapter to the PC. Run Nadcom and select the modulometer adjustments. The adjustment of the red modulometer is done in the same way as for a single modulometer. Enter a signal to obtain 0 dB output and adjust the needle so that it corresponds to 0 dB. For the green modulometer, remove the input signal and adjust the needle until it corresponds to -infinity. At the Nagra-V input, adjust the input signal to obtain 0 dB output level. Adjust the offset on Nadcom to get the needle at 0 dB for left and right channels (on Nadcom, settings for modulo 1 and 2).

Schematics:

PCB 9131 325 000

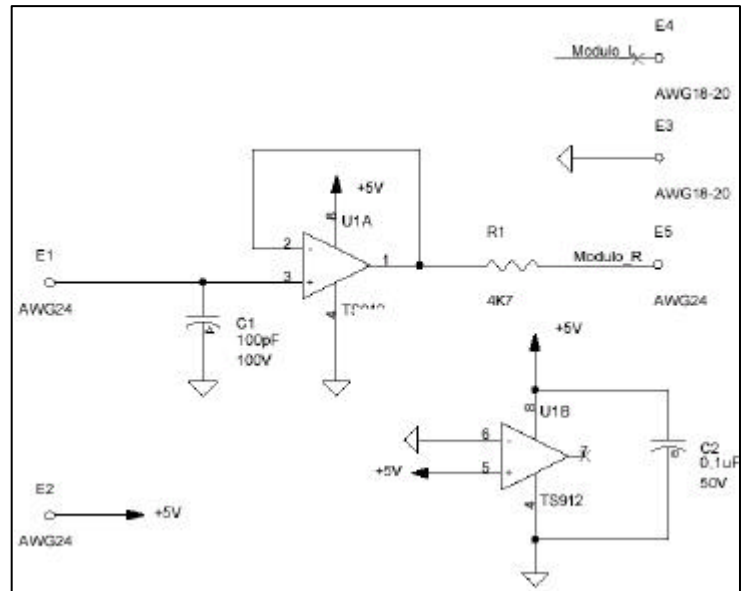
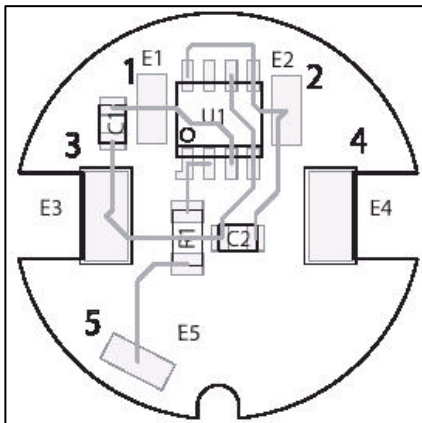

Wiring:

E1-U3 pin18, yellow 80 mm.

E2-U3 pin 19, red 80 mm.

E3-Left modulometer (red needle) white (from previous connector with the red-white and the white wire).

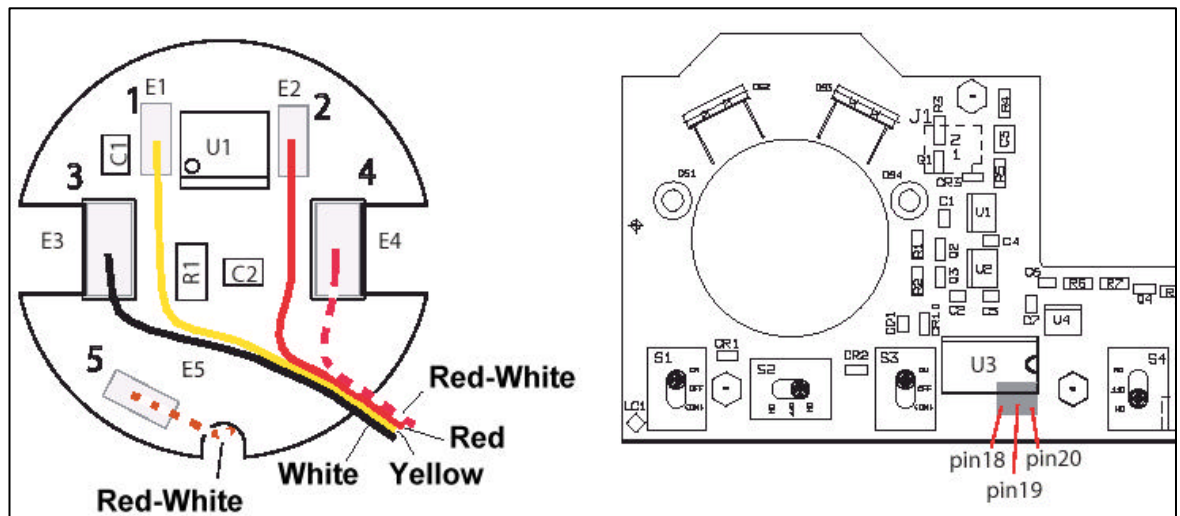

E4-Left modulometer (red needle) red-white (from previous connector with the red-white and the white wire).

E5-Right modulometer red-white.

Pin 20 of U3 is not used with the wiring but shows only the last pin on the IC :

(OME 31-018)

NAGRAVISION SA

April 11th, 2003