

NAD **SERVICE**
MANUAL

1155
STEREO PREAMPLIFIER

NAD 1155 SERVICE MANUAL

NOTE: This manual covers all versions.

A: U.S.A.

A1: Canada

B: U.K.

B1: Australia

C: Europe and others

C1: W-Germany

TABLE OF CONTENTS	PAGE
LOCATION MAP	2
SPECIFICATIONS	3 - 4
ALIGNMENT	5
WIRING DIAGRAM	6 - 7
P.C.B. LAYOUT DIAGRAM	8 - 9
SCHEMATIC DIAGRAM	10 - 11
EXPLODED VIEW PARTS LIST	12 - 13
EXPLODED VIEW	14
ELECTRICAL PARTS LIST	15 - 17

REAR PANEL

1. Phono Input.
2. Phono Ground.
3. MM/MC Selector.
4. Phono Capacitance.
5. CD/Video Input.
6. Tuner Input.
7. Tape 1 Rec/Play.
8. Tape 2 Rec/Play.
9. Preamp Output (Normal).
10. Preamp Output (High Level).
11. AC Line Cord.
12. AC Outlets. (Not in European models)

CAUTION: TO PREVENT ELECTRIC SHOCK DO NOT USE THIS (POLARIZED) PLUG WITH AN EXTENSION CORD, RECEPTACLE OR OTHER OUTLET UNLESS THE BLADES CAN BE FULLY INSERTED TO PREVENT BLADE EXPOSURE.

ATTENTION: POUR PREVENIR LES CHOC ELECTRIQUES NE PAS UTILISER CETTE FICHE POLARISEE AVEC UN PROLONGATEUR, UNE PRISE DE COURANT OU UNE AUTRE SORTIE DE COURANT, SAUF SI LES LAMES PEUVENT ETRE INSEREES A FOND SANS LAISSER AUCUNE PARTIE A DECOUVERT.

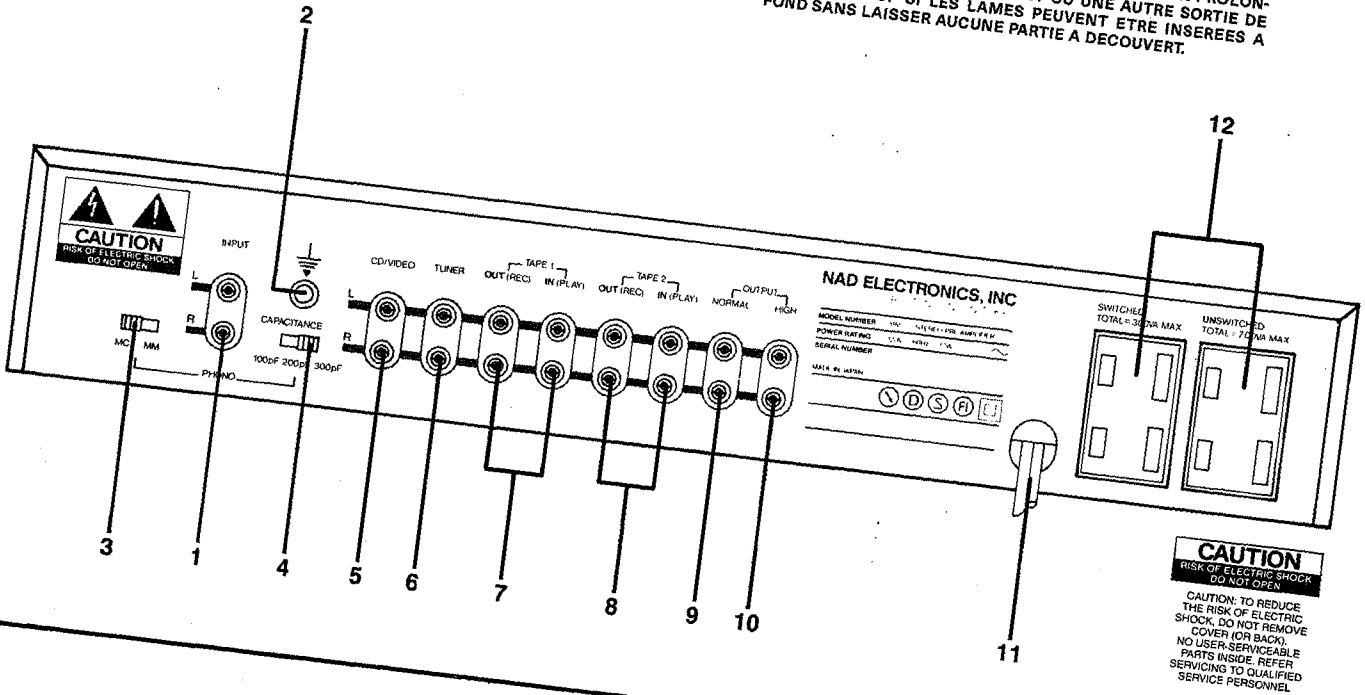

FRONT PANEL

1. Power.
2. Phones.
3. Bass.
4. Treble.
5. Bass EQ.
6. Infrasonic Filter Defeat.
7. Mono.
8. Recording Input Selector.
9. Listen Input Selector.
10. Low Level.
11. Loudness Compensation.
12. Volume/Balance.

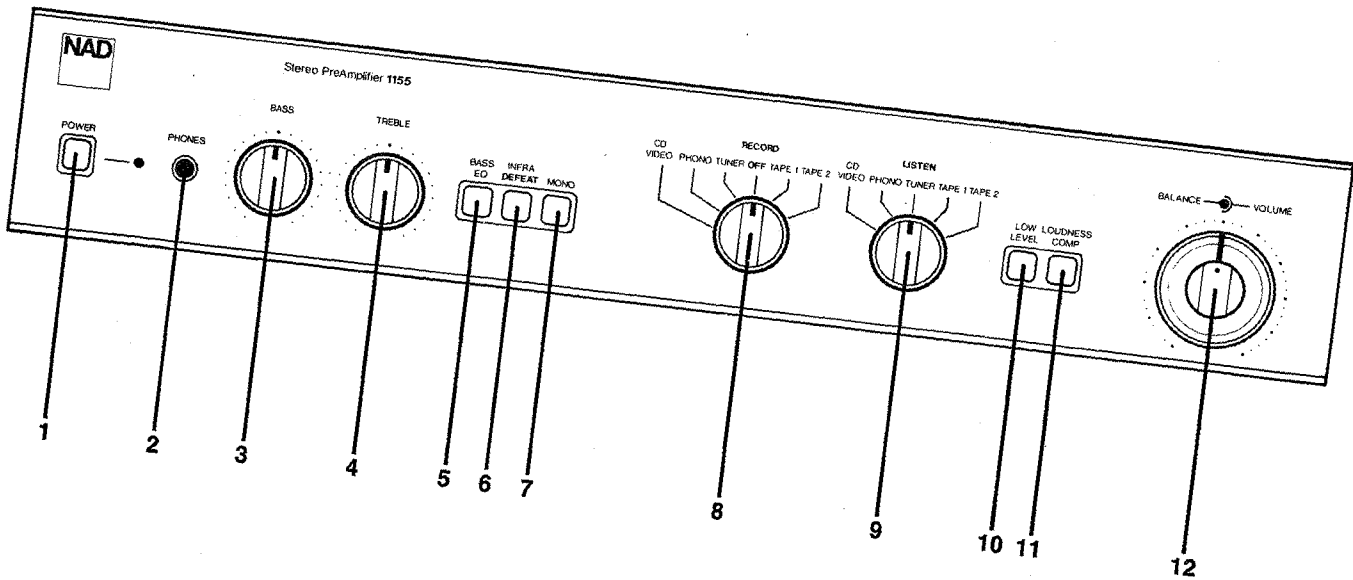

SPECIFICATIONS

Measured in accordance with EIA Standard RS-490 (formerly IHF A-202).

PHONO INPUT

Input impedance	MM: R = 47 Kohms C = 100/200/300 pF
	MC: R = 100 ohms C = 1000 pF
Input sensitivity (1 kHz)	MM: 1.2 mV for 0.5 V out 5 mV for 2 V out
	MC: 56 μ V for 0.5 V out 224 μ V for 2 V out
Input overload at 20 Hz/1 kHz/ 20 kHz	MM: 20/200/2000 mV MC: 1.2/12/90 mV
Signal/Noise ratio, IHF A-weighted, with cartridge connected	MM: 80 dB re 5 mV MC: 78 dB re 0.5 mV MC: 82 dB with shorted input
THD (20 Hz – 20 kHz) and IM Distortion at +30 dB level	< 0.02%
RIAA response accuracy	\pm 0.3 dB

LINE LEVEL INPUTS (Tuner, Tape, CD/Video)

Input impedance	R = 20 Kohms; C = 220 pF
Input sensitivity	80 mV for 0.5 V out 300 mV for 2 V out
Maximum input signal	> 10 V
Signal/Noise ratio, A-weighted	95 dB re 0.5 V out 107 dB re 2 V out
Frequency response, 20 Hz – 20 kHz	\pm 0.3 dB

OUTPUTS (Hi Level + 13.4 dB)

Output impedance	Tape: 130 ohms (buffered) Normal: 600 ohms High: 220 ohms Phones: 100 ohms (will drive all headphone impedances)
Maximum output level	Tape: 15 V into 10 K load Normal: 12 V into 20 K load, 6 V into 1 K load High: 15 V into 10 K load, 10 V into 600 ohms Phones: 15 V into 20 K ohms, 10 V into 600 ohms, 700 mV into 8 ohms
Tape output infrasonic filter	-3 dB at 15 Hz, 12 dB/Octave

CONTROLS

Treble	±7 dB at 10 kHz
Bass	±9 dB at 100 Hz
Bass equalization	+3 dB at 50 Hz +6 dB at 32 Hz +3 dB at 25 Hz
Infrasonic filter (switchable)	-3 dB at 15 Hz, 12 dB/Octave
Audio muting (low level)	-20 dB

PHYSICAL SPECIFICATIONS

Height x Width x Depth	7.5 x 42 x 27.6 cm 3 x 16.5 x 10.7 in.
Net weight	4.13 Kg (9 lb. 2 oz.)
Shipping weight	4.16 Kg (10 lb. 8 oz.)
Power Consumption	50/60 Hz at 110, 120, 220 or 240 VAC, 17 W

ALIGNMENT

+24V. REGULATOR ADJUSTMENT

- A. Connect voltmeter between collector Q601 (+24V regulator) and ground.
- B. Adjust R611 for reading of +23.5 – +24.0V VDC.

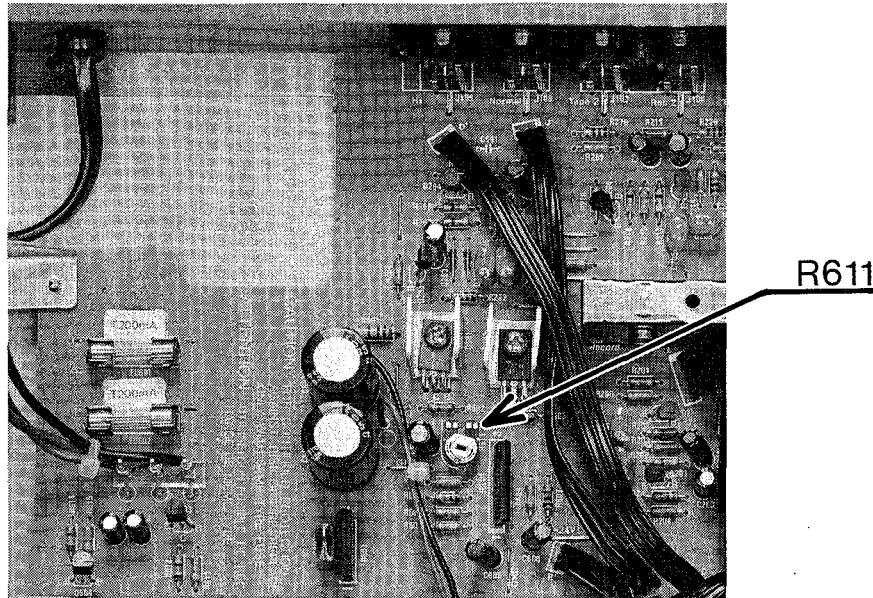

WIRING DIAGRAM

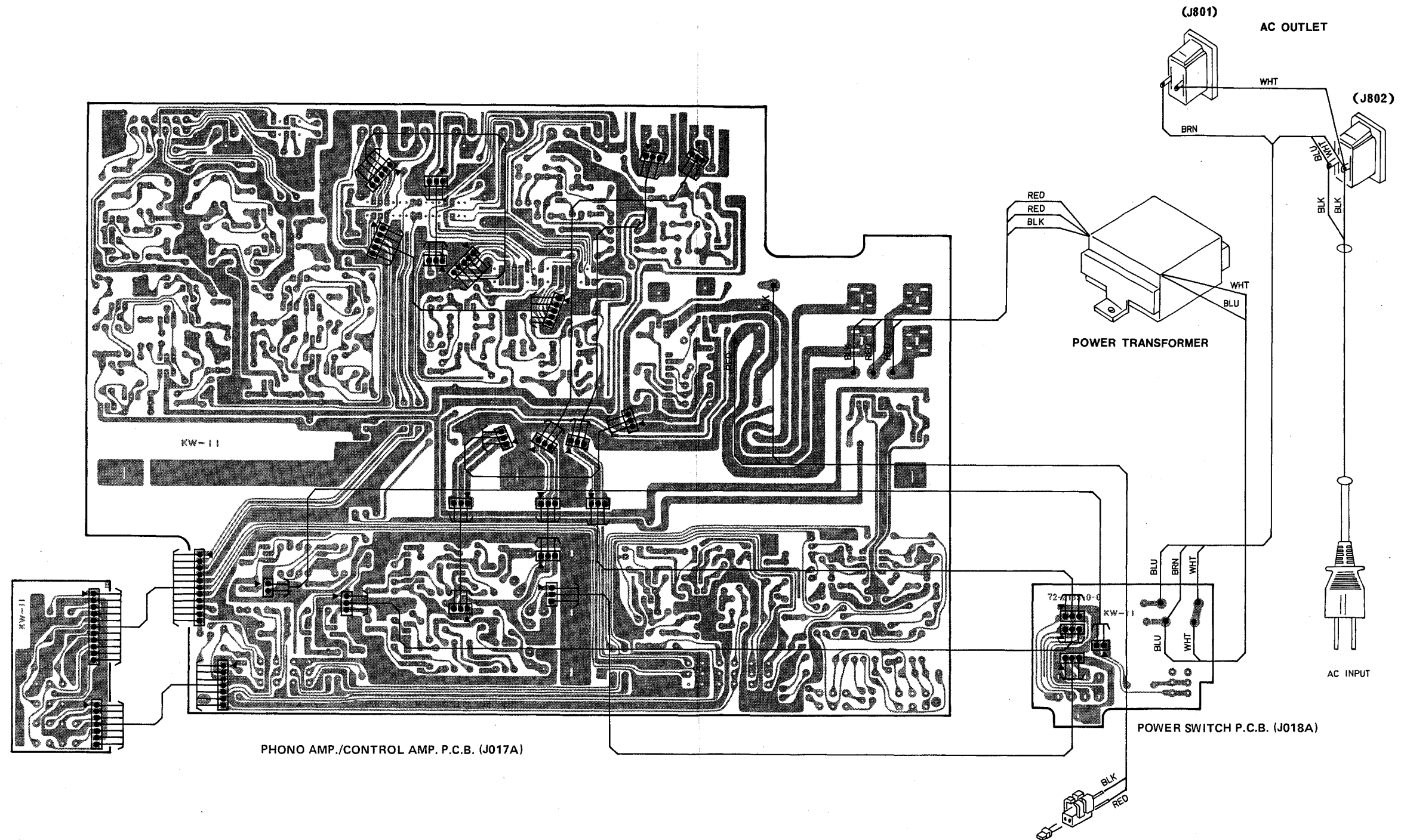

P.C.B. LAYOUT DIAGRAM

PHONO AMP./CONTROL AMP. PCB

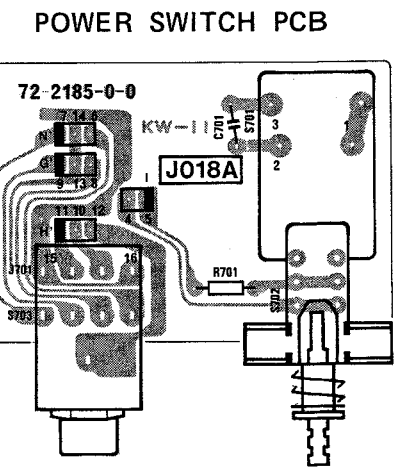
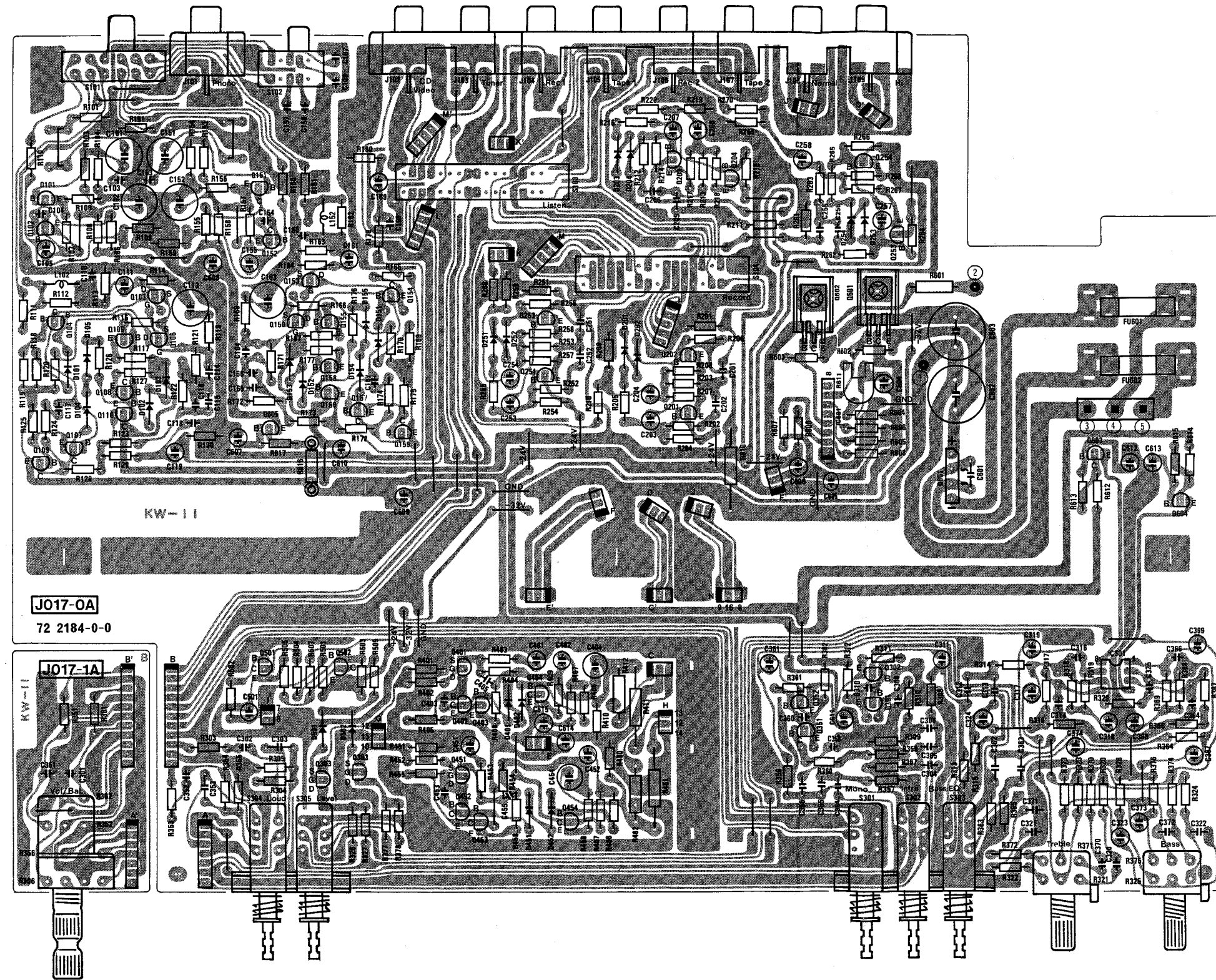

SCHEMATIC DIAGRAM NAD 1155 PREAMPLIFIER

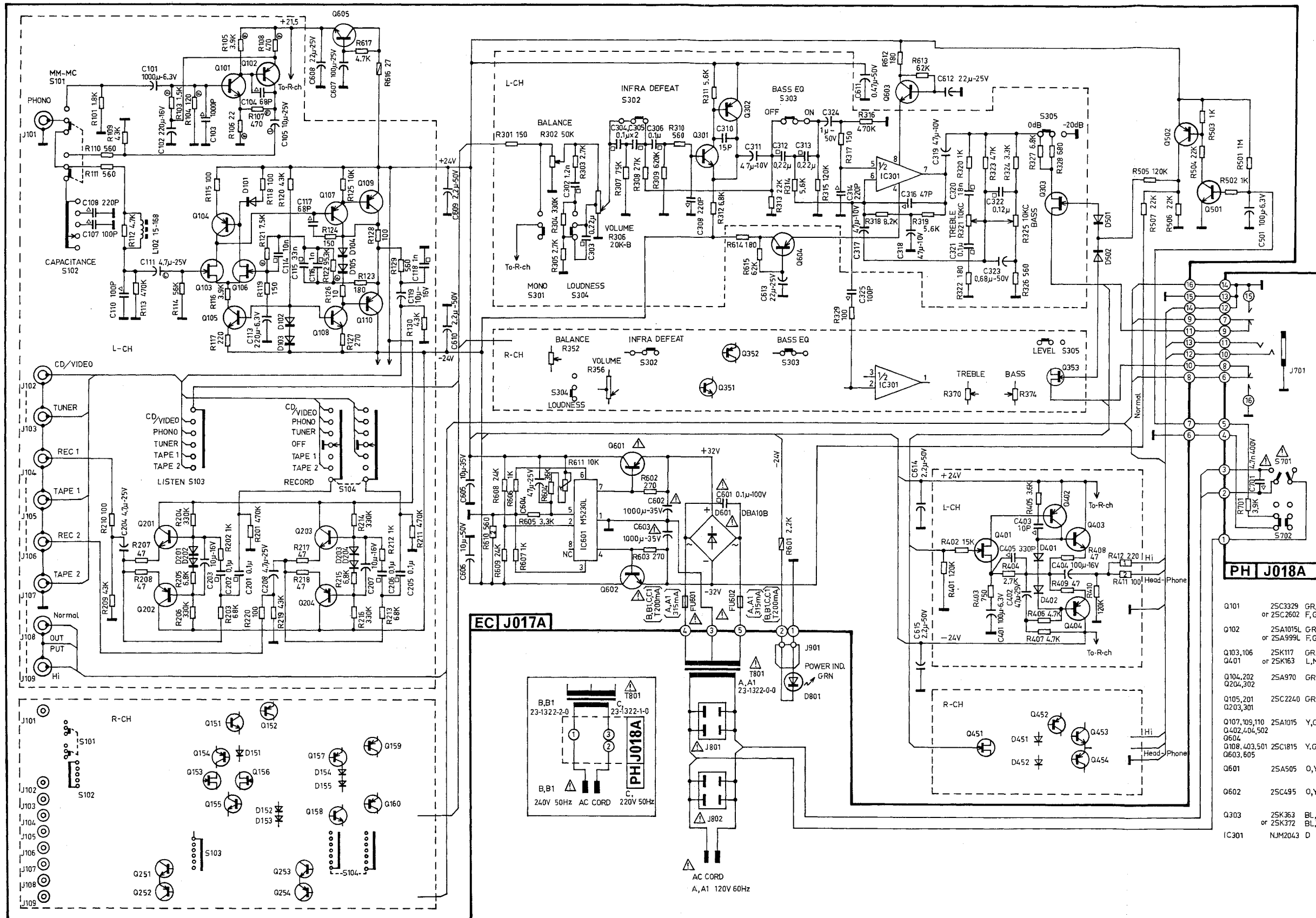

Q101	25C3329	GR,BL
	or 25C2602	F,G
Q102	25A1015L	GR
	or 25A999L	F,G
Q103,106	25K117	GR,BL
Q401	or 25K163	L,M
Q104,202	25A970	GR,BL
Q204,302		
Q105,201	25C2240	GR,BL
Q203,301		
Q107,109,110	25A1015	Y,G,R
Q402,404,502		
Q604		
Q108,403,501	25C1815	Y,GR
Q603,605		
Q601	25A505	O,Y
Q602	25C495	O,Y
Q303	25K363	BL,V
	or 25K372	BL,V
IC301	NJM2043	D

EXPLODED VIEW PARTS LIST

Ref. No.	Parts No.	Descriptions
1	63-6277-0-0	FRONT PANEL
2	62-1105-0-0	PUSH BUTTON - SELECTORS
3	62-1105-1-0	PUSH BUTTON - ON/OFF
4	62-3465-0-0	PUSH BUTTON FRAME - SINGLE HOLE
5	62-3466-0-0	PUSH BUTTON FRAME - TWO HOLES
6	62-3467-0-0	PUSH BUTTON FRAME - THREE HOLES
7	62-2317-0-0	ROTARY KNOB - TONE CONTROL/SELECTORS
8	62-2318-0-0	ROTARY KNOB - BALANCE
9	62-2319-0-0	ROTARY KNOB - VOLUME
10	92-2103-0-0	FOOT
11	63-1845-0-0	PLATE (POLYESTER)
12	63-1856-0-0	LABEL (WARNING : SHOCK HAZARD - DO NOT OPEN)
15	71-2606-0-0	FRONT SUBCHASSIS
16	71-2607-0-0	SIDE CHASSIS (L) (A A1 B B1)
	71-2607-1-0	SIDE CHASSIS (L) (C C1)
17	71-2592-0-0	SIDE CHASSIS (R)
18	71-1895-0-0	FRAME
19	92-1226-0-0	INSULATOR (PVC)
20	92-1229-0-0	INSULATOR (PVC)
21	71-2609-0-0	REAR PANEL (A A1)
	71-2610-0-0	REAR PANEL (B B1 C C1)
22	71-1896-0-0	TRANS STAND
23		WASHER (FIBER PLAIN 3.5-15-0.8)
24	71-3106-0-0	CABINET
25	71-3105-0-0	BOTTOM COVER
30	23-1322-0-0	POWER TRANSFORMER (A A1)
	23-1322-1-0	POWER TRANSFORMER (B B1)
	23-1322-2-0	POWER TRANSFORMER (C C1)
31	85- 258-0-0	POWER CORD (A)
	85- 240-0-0	POWER CORD (B)
	85- 259-0-0	POWER CORD (B1)
	85- 235-0-0	POWER CORD (C C1)
	85- 260-0-0	POWER CORD (A1)
32	62-3332-0-0	BUSHING - AC POWER CORD
33	82-2165-0-0	RECEPTACLE (A A1)
34	SLP-255B	LED (GREEN)
35	65- 129-0-0	SHAFT - SELECTOR
36	62-3472-0-0	BUSHING FOR SHAFT SELECTOR
37	62-3474-0-0	JOINT FOR SHAFT SELECTOR
38	87-3242-0-0	GROUND TERMINAL
39	AC331	INSULATOR
43	81-2227-0-0	POWER SWITCH (A A1)
	81-2245-0-0	POWER SWITCH (B B1 C C1)
44	82-2166-0-0	HEADPHONE JACK
45	J017A	PHONO AMP/CONTROL AMP PCB
46	J018A	POWER SWITCH PCB
47	41- 685-0-0	ROTARY POTENTIOMETER - BASS & TREBLE
48	41- 688-0-0	ROTARY POTENTIOMETER - VOLUME
49	81-2328-0-0	FUNCTION SWITCH BANK (3 SWITCHES)
50	81-2323-0-0	FUNCTION SWITCH BANK (2 SWITCHES)

Ref. No.	Parts No.	Descriptions
51	81- 448-0-0	SLIDE SWITCH - PHONO CAPACITANCE SELECTOR
52	81- 449-0-0	SLIDE SWITCH - PHONO MM/MC SELECTOR
53	82-2130-0-0	RCA CONNECTORS - SINGLE
54	82-2157-0-0	RCA CONNECTORS - DOUBLE
55	82-2159-0-0	RCA CONNECTORS - TRIPLE
56	81- 185-0-0	ROTARY SWITCH - RECORD SELECTOR
57	81- 186-0-0	ROTARY SWITCH - LISTEN SELECTOR
58	84- 213-0-0	RECEPTACLE FOR LED
60		TAPPING SCREW (PHILLIP'S HEAD 3 x 6 Cr)
61		TAPPING SCREW (PHILLIP'S HEAD 3 x 6 BLK)
62		TAPPING SCREW (PHILLIP'S HEAD 3 x 8 BLK)
63		TAPPING SCREW (WASHER HEAD 3 x 8 Cr)
64		TAPPING SCREW (WASHER HEAD 3 x 6 Cr)
65		MACHINE SCREW (PAN 3 x 6 Cr)
66		NUT (HEXAGON M4-7-3.2 Cr)
67		WASHER (TOOTHED LOCK B 4 Ni)
68		WASHER (PLAIN 4-10-0.8 Ni)
69		RETAINING RING (E TYPE 5mm)
70		CABINET SCREW WITH WASHER (4 x 6 BLK) (A A1 B B1)
71		MACHINE SCREW (PHILLIP'S HEAD 4 x 5 BLK) (C C1)
72		WASHER (PLAIN 4-8-0.8 BLK) (C C1)
73		HEAD PHONE JACK NUT (HEXAGON 12-14-2)
74		WASHER (PLAIN 12-18-0.5)
75		TONE CONTROLS NUT (HEXAGON 7-11-2)
76		WASHER (PLAIN 7-12-0.5)
77		VOLUME CONTROL NUT (9-11-2)
78		WASHER (PLAIN 9-14-0.5)

EXPLODED VIEW

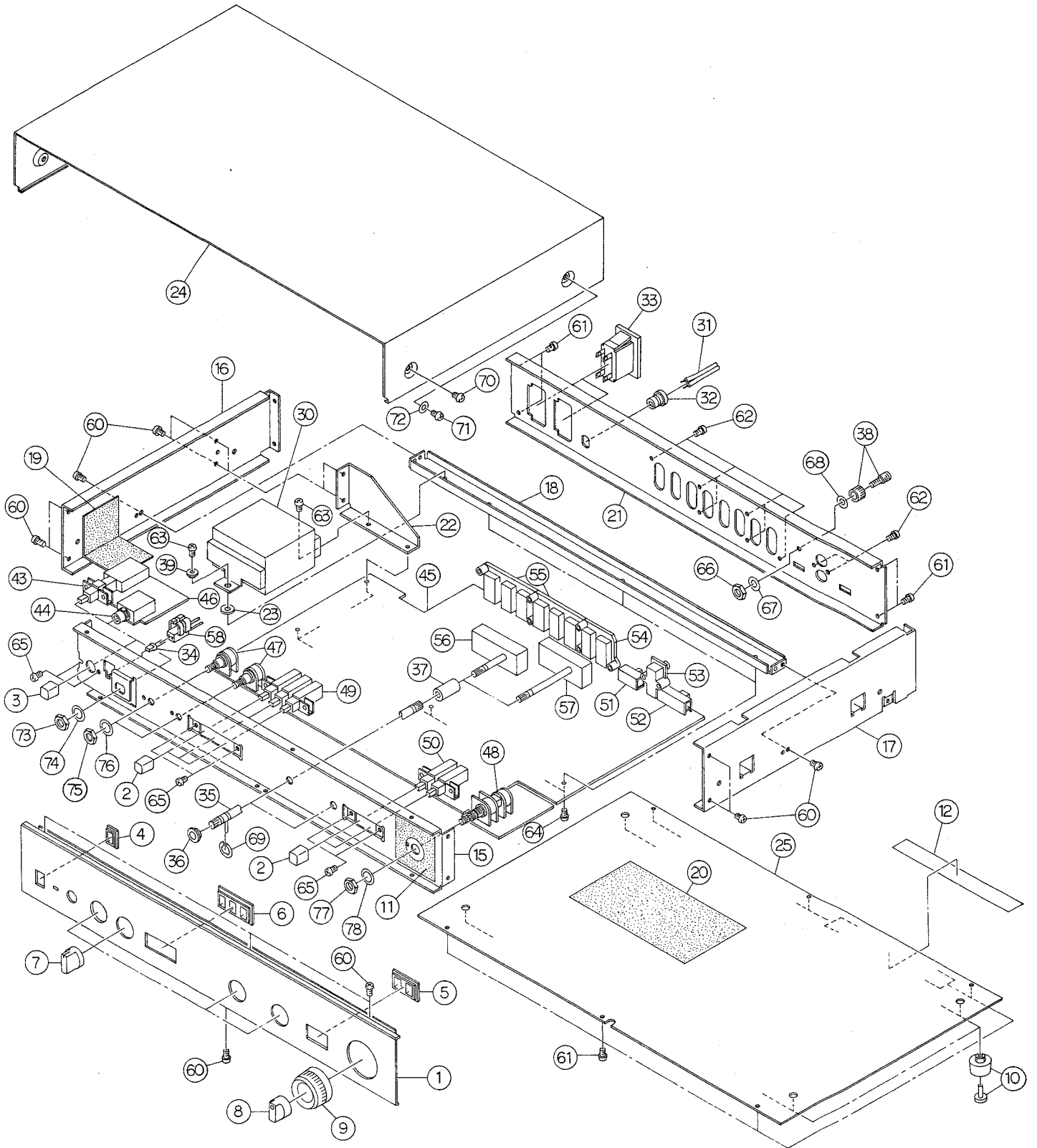

ELECTRICAL PARTS LIST

NOTE: This is not a complete electrical parts list.

SYMBOL NO.	PARTS NO.	DESCRIPTIONS
IC601.	M5230L	INTEGRATED CIRCUIT
IC301.	NJM2043D	"
Q101, Q151.	2SC3329	TRANSISTOR
Q102, Q152.	2SA1015	"
Q103, Q153,	2SK117	"
Q106, Q156.	"	"
Q104, Q154,	2SA970	"
Q202, Q252,	"	"
Q204, Q254,	"	"
Q302, Q352.	"	"
Q105, Q155,	2SC2240	"
Q201, Q251,	"	"
Q203, Q253,	"	"
Q301, Q351.	"	"
Q107, Q157,	2SA1025	"
Q109, Q159,	"	"
Q110, Q160,	"	"
Q402, Q452,	"	"
Q404, Q454,	"	"
Q502, Q604.	"	"
Q108, Q158,	2SC1815	"
Q403, Q453,	"	"
Q501, Q603, Q605.	"	"
Q303, Q353.	2SK363	"
Q601.	2SA505	"
Q602.	2SC495	"
Q401, Q451.	2SK117	"
D601.	DBA10B	DIODE
D101, D151,	1S1588	"
D102, D152,	"	"
D103, D153,	"	"
D104, D154,	"	"
D105, D155,	"	"
D201, D251,	"	"
D202, D252,	"	"
D203, D253,	"	"
D204, D254,	"	"
D401, D451,	"	"
D402, D452,	"	"
D501, D502.	"	"
D801.	SLP255B	L. E. D.

