

**501  
COMPACT DISC  
PLAYER**

**501  
COMPACT DISC  
PLAYER**

# **SERVICE MANUAL**

**NAD**

## SAFETY INFORMATION

### CAUTION

CAUTION-	INVISIBLE LASER RADIATION WHEN OPEN AND INTER-LOCK DEFECTED. AVOID EXPOSURE TO BEAM
VORSICHT	UNSEH-BARE LASERSTRÄHLUNG TRITT AUS, WENN DECKEL GEÖFFNET UND KEIN SICHERHEITSSPERRENMECHANISMUS BEFRIEDIGEND FUNKTIONIERT. VERMEIDEN SIE STRAHLEN-AUSSETZUNG
VARNING-	OSYMLIG LASERSTRÅLNING DENNÅN DÖRR ÄR ÖPPNAD OCH SPÄRRAR JÄMFÖRLÖST STRÅLEN ÄR FARLIG.
ADVARSEL-	USYMLIG LASERSTRÅLING VED ÅBNING, NÅR SIKKERHEDSÅFSPERREREN ER UDE AF FUNKTION. UNDSØG ÅRSÅG TIL DIT STRÅLE-UDSLÆP
ATTENTION-	PRÉSENCE D'UN LASER À ÉMISSION ALTERNATIVE DANGEREUSE SI OUVERT AVEC UN ENCLANCHEMENT DE SÉCURITÉ ANOMAL

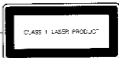
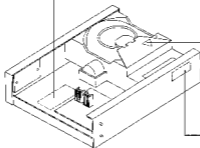

**IMPORTANT NOTE:** Before using the player you must remove the two red transit clamps that are fitted on the underside of the player. To remove the two transit clamps turn the player upside down and turn each clamp anticlockwise about quarter of a turn until it is free. The clamps can now be gently lifted out of the player. Retain the clamps for future use should you wish to transport the player. They can be refitted by reversing the removal procedure above.



The lightning flash with arrowhead, within an equilateral triangle, is intended to alert the user of the presence of uninsulated "dangerous voltage" within the product's enclosure that may be of sufficient magnitude to constitute a risk of electric shock to persons.



The exclamation point within an equilateral triangle is intended to alert the user of the presence of important operating and maintenance (servicing) instructions in the literature accompanying the appliance.

THIS DEVICE COMPLIES WITH PART 15 OF THE FCC RULES. OPERATION IS SUBJECT TO THE FOLLOWING TWO CONDITIONS:  
(1) THIS DEVICE MAY NOT CAUSE HARMFUL INTERFERENCE, AND  
(2) THIS DEVICE MUST ACCEPT ANY INTERFERENCE RECEIVED, INCLUDING INTERFERENCE THAT MAY CAUSE UNDESIRABLE OPERATION.

# CONTENTS

DESCRIPTION	PAGE
SPECIFICATIONS.....	3
REAR PANEL /FRONT PANEL VIEW.....	4
BLOCK DIAGRAM.....	5
WIRING DIAGRAM.....	6
DISASSEMBLY INSTRUCTIONS.....	7
ADJUSTMENT .....	8
IMPORTANT NOTES.....	9
SCHEMATIC DIAGRAM (MAIN PCB).....	10-11
PCB LAYOUT (MAIN PCB).....	12-13
IC BLOCK DIAGRAM .....	14
SCHEMATIC DIAGRAM (DAC PCB).....	15
PCB LAYOUT (DAC PCB).....	16
SCHEMATIC DIAGRAM (DISPLAY).....	17
PCB LAYOUT (DISPLAY).....	18
TROUBLE SHOOTING GUIDE.....	19
EXPLODED VIEW.....	20-21
EXPLODED VIEW PARTS LIST.....	22
MECHANISM EXPLODED VIEW.....	23-24
PARTS LIST.....	25-26
PACKING DIAGRAM.....	27
NOTES.....	28

## SPECIFICATIONS

Disc capacity	One disc, 80mm or 120mm
Decoding	Bitstream converter
Laser pickup	Single beam
Mechanism	CDM4
Frequency Response	20Hz-20kHz-0.1/-0.5dB
THD (plus noise)	0.004% at 1kHz, Max. Rec. Level
Linearity	+/-0.5dB; (0 to -90dB)
Signal/Noise Ratio	99dB A-weighted
Channel Separation	-90dB at 1kHz -88dB at 10kHz
Output Impedance	100 ohm
Output Level at 0dB	2.7 Vrms

### PHYSICAL SPECIFICATIONS

Dimensions (Width x Height x Depth)	420 x 93 x 295mm
Net weight	6.0Kg
Shipping weight	7.1Kg

## REAR PANEL / FRONT PANEL VIEW

### REAR PANEL

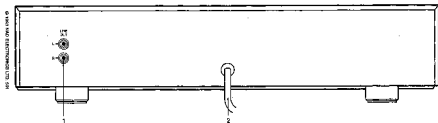

1. LINE OUT
2. AC LINE CORD

### FRONT PANEL

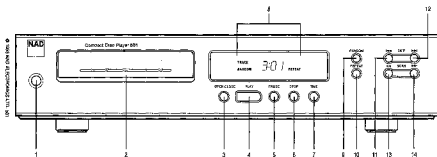

1. POWER ON/OFF
2. DISC DRAWER
3. OPEN CLOSE
4. PLAY
5. PAUSE
6. STOP
7. TIME
8. DISPLAY
9. RANDOM
10. REPEAT
11. SKIP Back (|<<)
12. SKIP Forward (>>|)
13. SCAN Back (<<)
14. SCAN Forward (>>)

# BLOCK DIAGRAM

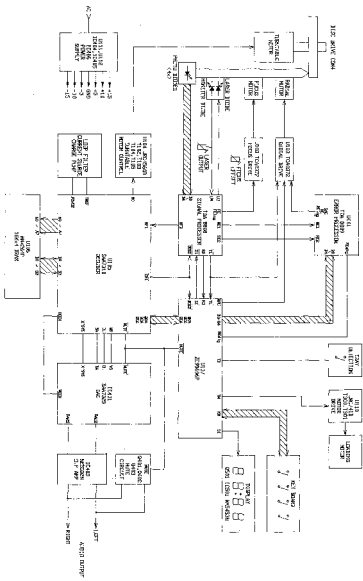

# WIRING DIAGRAM

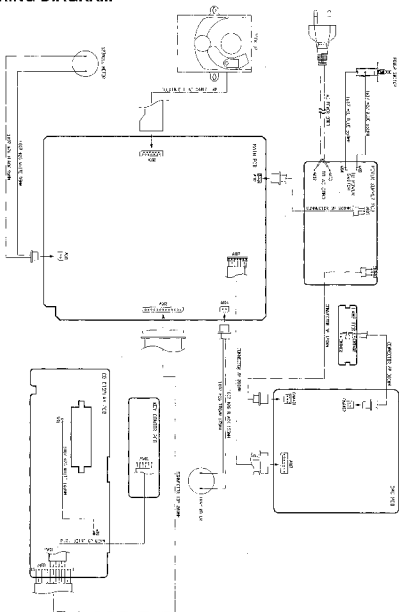

# DISASSEMBLY INSTRUCTIONS

## TOP COVER REMOVAL

1. Remove machine screws M 4.0x6.0 ( ① to ④ ) from the side panels.  
Remove tapping screw M 3.0x6.0 ( ⑤ ) from the back panel.  
Refer to figure No. 1.

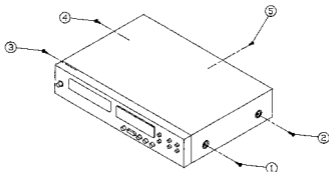

Fig. 1.

2. Pull both sides of the TOP COVER slightly outwards and tilt approx. 35° and then remove in the direction as indicated by pointer ⑦ in figure No. 2.

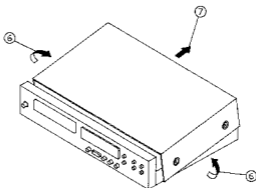
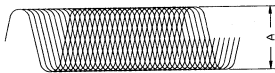
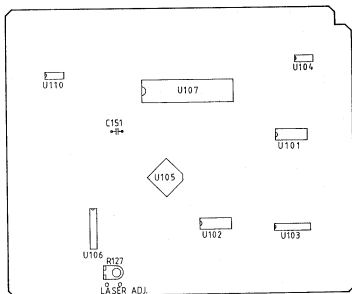

Fig. 2.



## ADJUSTMENT POINTS DIAGRAM



$$A = 1.0 \pm_{-0.1}^{+0.2} V_{p-p}$$

### LASER CURRENT ADJUSTMENT:

The integrated circuitry used in the CD PCB eliminates the need for most adjustments by incorporating self-adjusting circuitry; however, when parts in the servo circuitry or CD mechanism are replaced, a laser current adjustment should be performed. Follow steps below:

1. Insert the test disc (SONY Type 4, YEDS 18).
2. Make sure the power is OFF.
3. Connect a high-impedance voltmeter across the test points LASER ADJ.
4. Turn the power ON and press the Play button.
5. When track 1 starts playing, adjust R127 for 50mV  $\pm$  2mV.

## IMPORTANT NOTES

### INSTRUCTIONS FOR HANDLING OPTICAL-SYSTEM-BLOCK PICK-UP

Electrostatic breakdown of the laser diode in the optical-system-block may occur due to a potential difference caused by the electrostatic charge accumulated on clothing, body, etc. A ground must be provided as follows to prevent any electrostatic discharge during unpacking or repair work.

1. Body Ground.  
Be sure to wear a grounding band (1M ohm) that is properly grounded to remove any static electricity from your clothing or body.
2. Ground for Work Bench  
Be sure to place a conductive sheet (1M ohm) or copper plate with proper grounding on the work bench or other surface on which the pick-up is to be placed.
3. Because a static electricity charge on clothing does not discharge through the body grounding band, do not let clothing contact the pick-up unit.

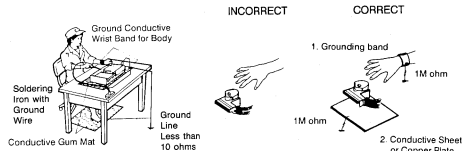

**NOTE:** Laser diodes are so susceptible to damage from static electricity that even if a static discharge does not ruin the diode, it can shorten its life or cause it to work improperly.

### PRECAUTIONS FOR CHECKING BEAM EMISSION OF LASER DIODE

The laser beam of this unit is focused on the reflecting surface of the objective lens in the optical system block. Therefore, keep your eyes at least 12 inches (30 cm) away from the objective lens when the laser diode is ON.

(Checking Method for Laser Diode and Focus Search Function.)

When the POWER switch is turned ON after the chucking arm is removed, observe the objective lens and confirm that the following operations are performed properly.

(The optical system block should be at the lead-in area position before chucking arm is removed)

- (1) The laser should be at the innermost position after the chucking arm is removed.
- (2) The diffused light of the laser beam should be seen when the POWER switch is turned ON.
- (3) Vertical (up and down) movement of the objective lens (several times) will take place.

# SCHEMATIC DIAGRAM (MAIN PCB)

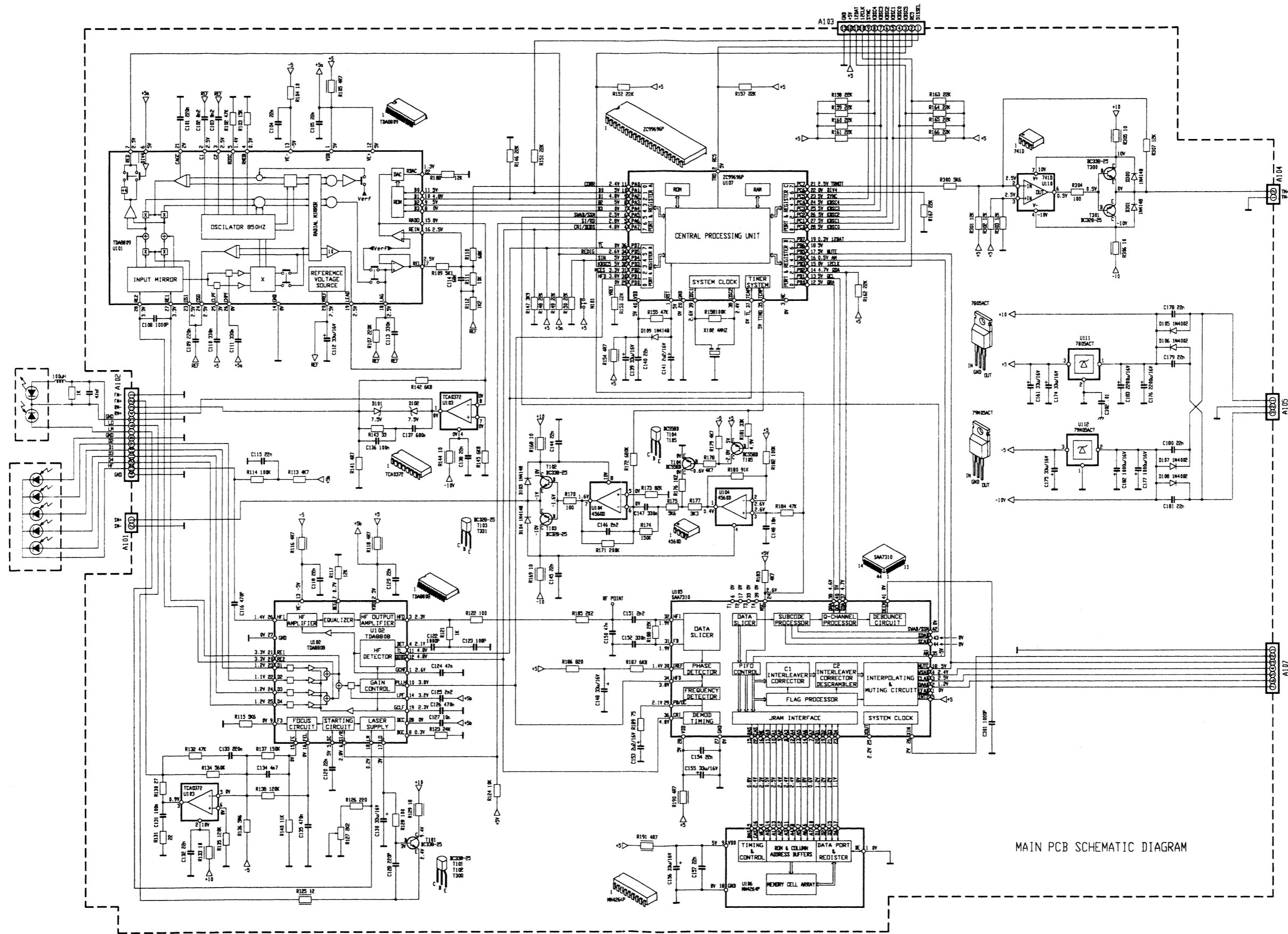

MAIN PCB SCHEMATIC DIAGRAM

PCB LAYOUT (MAIN PCB)

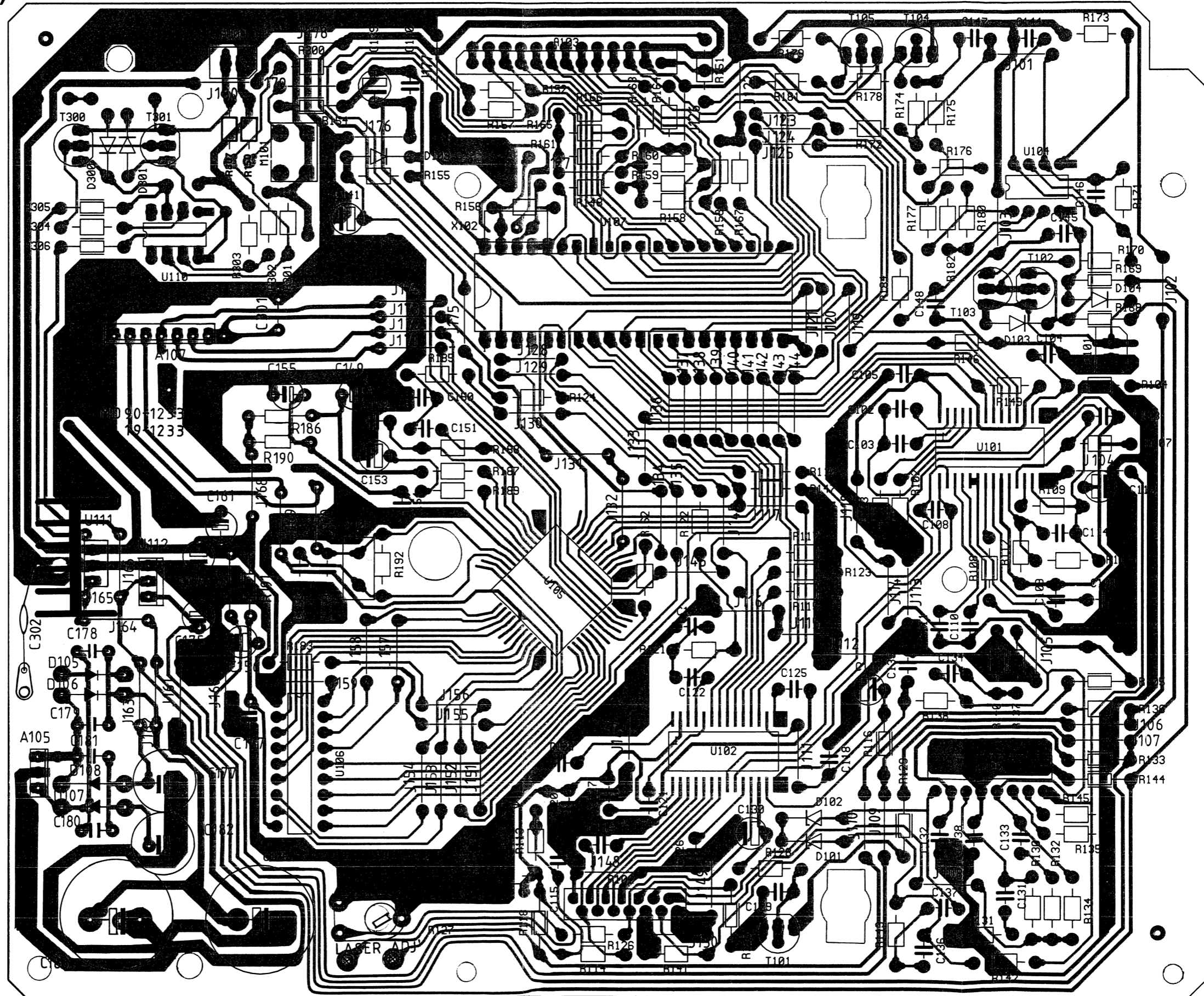

# IC BLOCK DIAGRAM

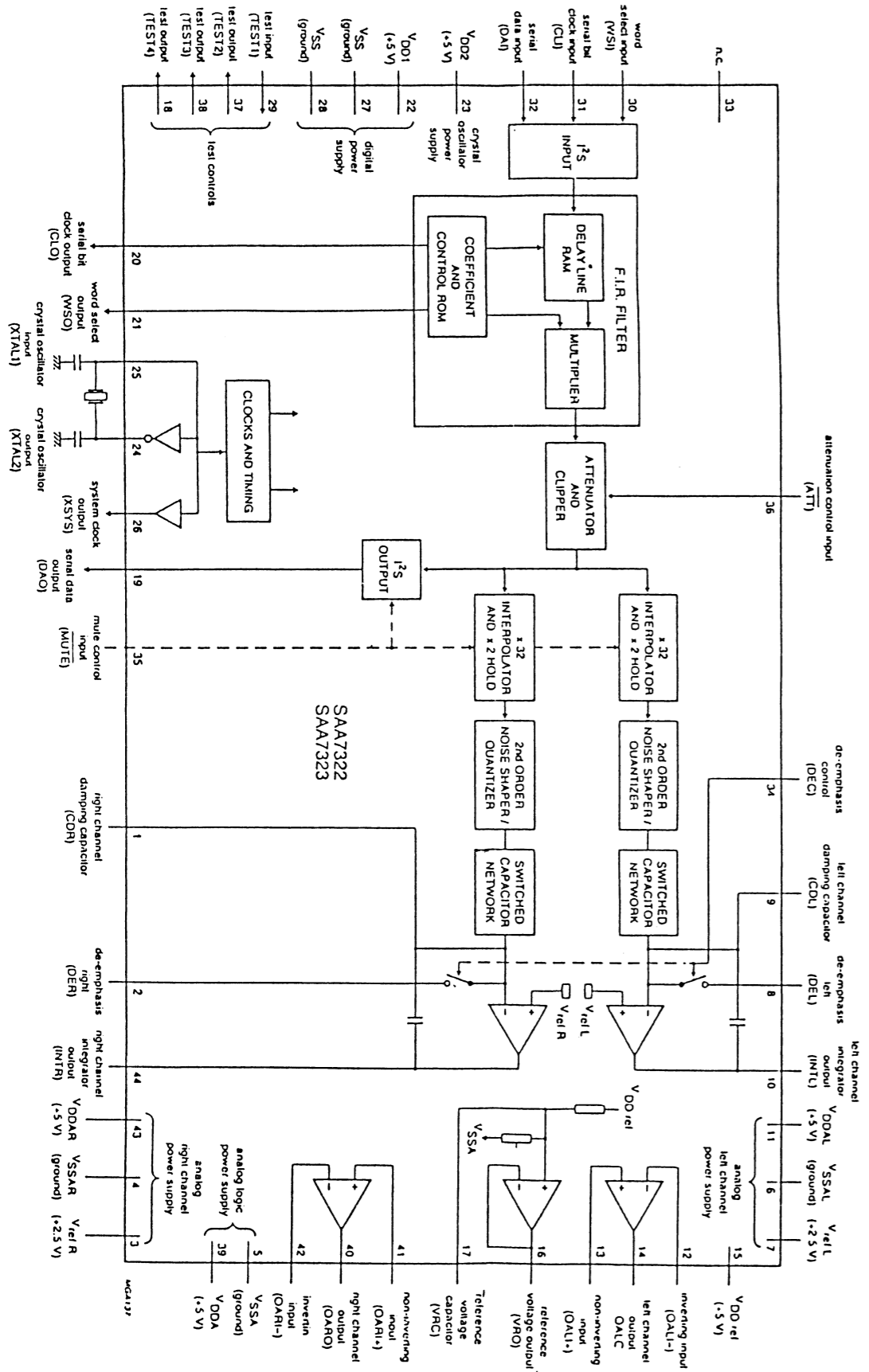

# SCHEMATIC DIAGRAM (DAC PCB)

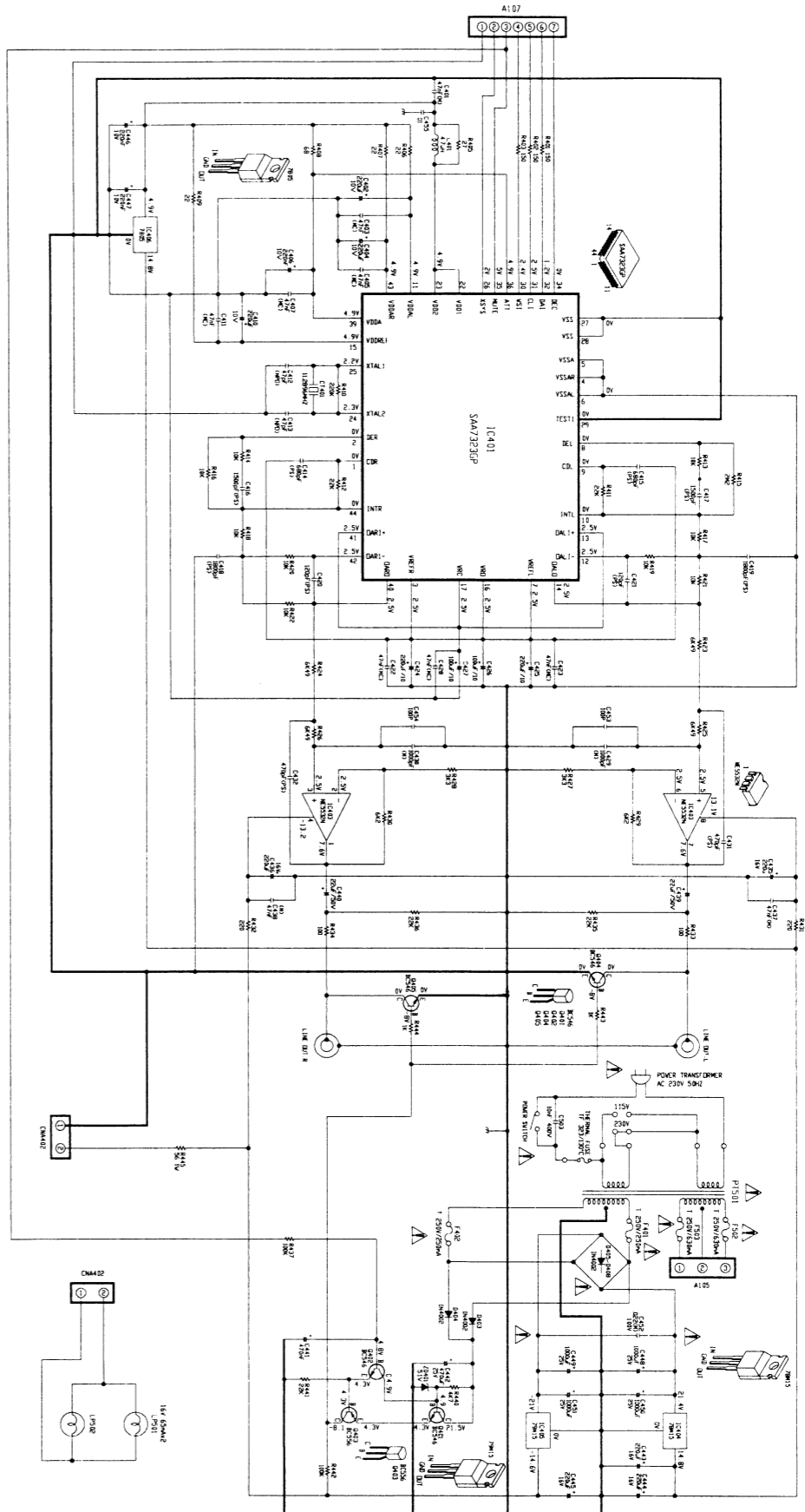

NOTE: ALL RESISTANCE VALUES IN Ω, EQUIVALENT NOTATION.  
 2. THE VALUE OF RESISTORS IS 1/4W UNLESS OTHERWISE NOTED.  
 3. ALL CAPACITANCE VALUES ARE IN μ UNLESS OTHERWISE NOTED.  
 4. ALL CAPACITORS ARE POLARIZED UNLESS OTHERWISE NOTED.  
 5. ALL CAPACITORS ARE POLARIZED UNLESS OTHERWISE NOTED.  
 6. ALL CAPACITORS ARE POLARIZED UNLESS OTHERWISE NOTED.  
 7. ALL CAPACITORS ARE POLARIZED UNLESS OTHERWISE NOTED.  
 8. ALL CAPACITORS ARE POLARIZED UNLESS OTHERWISE NOTED.  
 9. ALL CAPACITORS ARE POLARIZED UNLESS OTHERWISE NOTED.  
 10. ALL CAPACITORS ARE POLARIZED UNLESS OTHERWISE NOTED.

DAC PCB SCHEMATIC DIAGRAM

# PCB LAYOUT (DAC PCB)

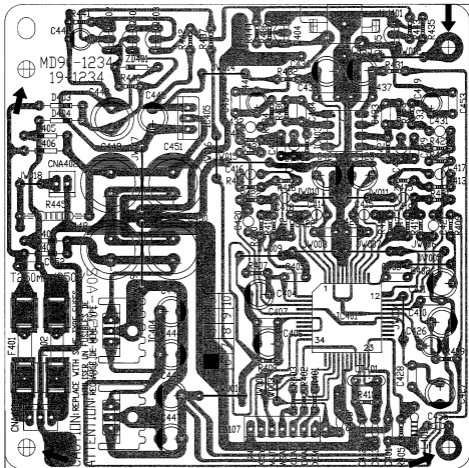

# SCHEMATIC DIAGRAM (DISPLAY)

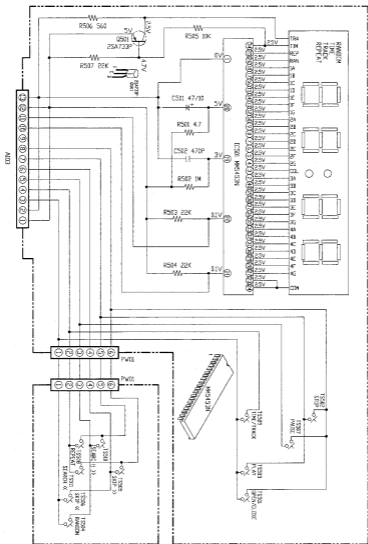



# EXPLODED VIEW

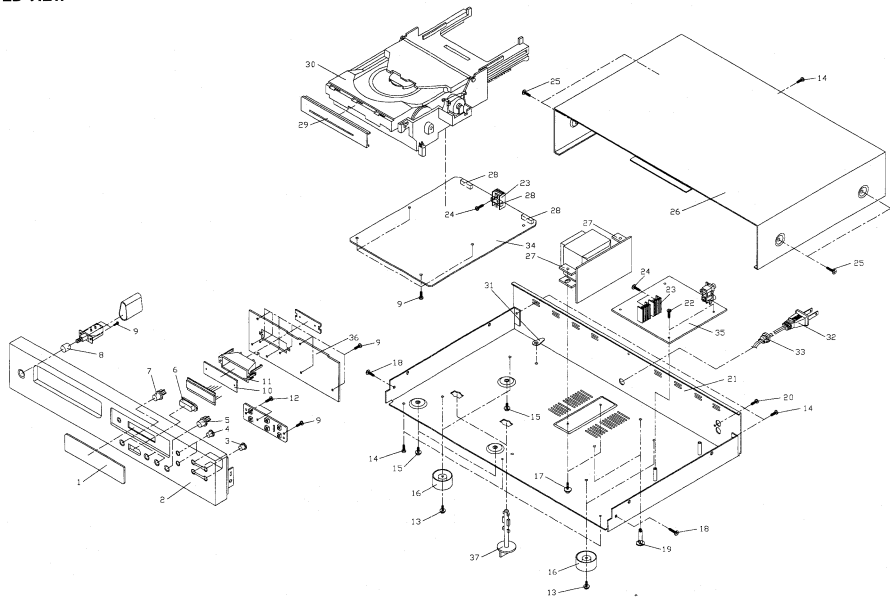



## EXPLODED VIEW PARTS LIST

ITEM	PART NO.	DESCRIPTION	Q'TY
1	101-00501-001	DISPLAY WINDOW	1
2	104-00501-001	FRONT PANEL	1
3	102-00501-004	FUNCTION KNOB (B)	4
4	102-00501-005	FUNCTION KNOB	2
5	102-00501-006	FUNCTION KNOB (C)	1
6	102-00501-003	PLAY KNOB	1
7	102-00501-002	FUNCTION KNOB (A)	3
8	102-00501-001	POWER KNOB	1
9	130-03010-013	TAPPING SCREW PS 3#x10R	15
10	101-00501-002	FILTER PLATE	1
11	106-00501-001	LCD HOLDER	1
12	130-03008-024	TAPPING SCREW PS 3#x8R	2
13	128-03006-W14	TAPPING SCREW PS 3#x6R	4
14	128-03006-014	TAPPING SCREW PS 3#x6R	6
15	130-03010-W14	TAPPING SCREW PS 3#x10R	3
16	113-00501-001	FOOT	4
17	131-04014-W13	MACHINE SCREW PM 4#x14R/10#	2
18	128-03006-024	TAPPING SCREW PS 3#x6R	2
19	055-00501-001	PCB SUPPORT	2
20	130-03010-014	TAPPING SCREW PS 3#x10R	1
21	122-00501-001	BOTTOM CASE	1
22	131-03008-013	MACHINE SCREW PM 3#x8Rx0.5	2
23	111-00610-001	HEAT SINK	3
24	128-03006-014	TAPPING SCREW PM 3#x6R TYPE-3	3
25	149-00501-001	TAPPING SCREW PS 4#x6R TYPE-3	4
26	122-00501-002	TOP COVER	1
27	105-00405-008	TRANSFORMER BRACKET	2
28	112-00501-001	SPONGE	3
29	118-00501-001	CD DOOR	1
30	655-00501-001	CD MECHANISM	1
31	125-00030-001	LUG 3#	1
32*C,B1	043-04600-001	AC POWER CORD SP-021A (C,B1)	1
32*AH	043-00100-001	AC POWER CORD (AH)	1
33	055-07150-001	POWER CORD STOPPER SR-4N-4	1
34	610-00501-001	MAIN AMP PCB ASS'Y	1
35	613-00501-001	DAC PCB ASS'Y	1
36	612-00501-001	CD DISPLAY PCB ASS'Y	1
37	106-00501-008	TRANSPORTS LOCKING	2

# MECHANISM EXPLODED VIEW

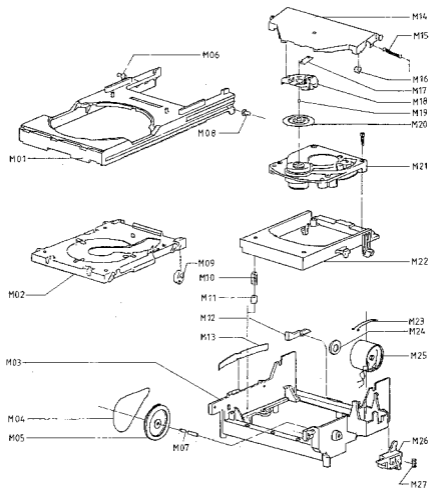

## MECHANISM EXPLODED VIEW PARTS LIST

ITEM	PART NO	DESCRIPTION	Q'TY
M01	317 10005A	TRAY	1
M02	317 10003B	LIFT PLATE	1
M03	259 10002C	CHASSIS	1
M04	017 40002	BELT	1
M05	077 30005	GEAR WHEEL	1
M06	271 30004	GUIDE	2
M07	316 40005	SHAFT	1
M08	271 30003	GUIDE	2
M09	151 40001	ROLLER LIP	2
M10	172 40016	COMPRESSION SPRING	4
M11	078 40002	SUSPENSION GROMMET	4
M12	209 40001A	TUMBLER	1
M13	172 30015	FLAT SPRING	1
M14	300 10004C	LID	1
M15	172 40017	TENSION SPRING	2
M16	151 40002	ROLLER LID	2
M17	300 40005	PIVOT PLATE	1
M18	258 20004A	CENTRING RING	1
M19	013 40001	BALL	1
M20	258 30003	PRESSURE RING (CARRIER RING)	1
M21	480 32403	CDM4 MINI	1
M22	259 10003C	SUPPORT PIECE	1
M23	172 40014	SPRING	1
M24	139 40003A	PULLEY	1
M25	118 40001	LOADER MOTOR	1
M26	255 30003C	SWITCH BRACKET	1
M27	172 40013	COMPRESSION SPRING	1

# PARTS LIST

## 501 PARTS LIST

SYMBOL NO.	REF. NO.	PART NO.	DESCRIPTION	SPECIFICATION	Q'TY
<b>CAPACITORS</b>					
C101	014-22401-063	014-22401-063	CAP. METAL.	0.22uF	63V
C102, C103	014-82201-063	014-82201-063	CAP. METAL.	0.0022uF	63V
C108	014-10201-063	014-10201-063	CAP. METAL.	0.001uF	63V
C109	014-22401-063	014-22401-063	CAP. METAL.	0.22uF	63V
C110, C111	014-33301-063	014-33301-063	CAP. METAL.	0.033uF	63V
C112	089-33602-016	089-33602-016	CAP. EL.	33uF	+/-10% 16V
C113	014-33401-063	014-33401-063	CAP. METAL.	0.33uF	63V
C114	014-68301-063	014-68301-063	CAP. METAL.	0.068uF	63V
C117	089-33602-016	089-33602-016	CAP. EL.	33uF	+/-10% 16V
C121	014-22401-063	014-22401-063	CAP. METAL.	0.22uF	63V
C122	014-10201-063	014-10201-063	CAP. METAL.	0.001uF	63V
C124	014-47301-063	014-47301-063	CAP. METAL.	0.047uF	63V
C125	014-22201-063	014-22201-063	CAP. METAL.	0.0022uF	63V
C126	014-47401-063	014-47401-063	CAP. METAL.	0.47uF	63V
C127	014-10301-063	014-10301-063	CAP. METAL.	0.01uF	63V
C130	089-33602-016	089-33602-016	CAP. EL.	33uF	+/-10% 16V
C131	014-10401-063	014-10401-063	CAP. METAL.	0.1uF	63V
C133	014-22401-063	014-22401-063	CAP. METAL.	0.22uF	63V
C134	014-47201-063	014-47201-063	CAP. METAL.	0.0047uF	63V
C135	014-47401-063	014-47401-063	CAP. METAL.	0.47uF	63V
C137	014-10401-063	014-10401-063	CAP. METAL.	0.1uF	63V
C139	014-68401-063	014-68401-063	CAP. METAL.	0.68uF	63V
C139	089-33602-016	089-33602-016	CAP. EL.	33uF	+/-10% 16V
C141	089-22502-016	089-22502-016	CAP. EL.	2.2uF	+/-10% 16V
C146	014-22201-063	014-22201-063	CAP. METAL.	0.0022uF	63V
C147	014-33401-063	014-33401-063	CAP. METAL.	0.33uF	63V
C148	014-18301-063	014-18301-063	CAP. METAL.	0.018uF	63V
C149	089-33602-016	089-33602-016	CAP. EL.	33uF	+/-10% 16V
C151	014-22201-063	014-22201-063	CAP. METAL.	0.0022uF	63V
C152	014-33401-063	014-33401-063	CAP. METAL.	0.33uF	63V
C153	089-22502-016	089-22502-016	CAP. EL.	2.2uF	+/-10% 16V
C155, C156	089-33602-016	089-33602-016	CAP. EL.	33uF	+/-10% 16V
C161	089-33602-016	089-33602-016	CAP. EL.	33uF	+/-10% 16V
C174, C175	089-33602-016	089-33602-016	CAP. EL.	33uF	+/-10% 16V
C176	008-22802-016	008-22802-016	CAP. EL.	2200uF	+/-10% 16V
C177	008-10802-016	008-10802-016	CAP. EL.	1000uF	+/-10% 16V
C182	008-10802-016	008-10802-016	CAP. EL.	1000uF	+/-10% 16V
C183	008-22802-016	008-22802-016	CAP. EL.	2200uF	+/-10% 16V
C301	014-10201-063	014-10201-063	CAP. METAL.	0.001uF	63V
C401	088-47301-010	088-47301-010	CAP. MYLAR	0.047uF	+/-5% 50V
C402	089-22702-010	089-22702-010	CAP. EL.	220uF	+/-10% 10V
C403	061-47303-050	061-47303-050	CAP. M.C.	0.047uF	+/-5% 50V
C404	089-22702-010	089-22702-010	CAP. EL.	220uF	+/-10% 10V
C405	061-47303-050	061-47303-050	CAP. M.C.	0.047uF	+/-5% 50V
C406	089-22702-010	089-22702-010	CAP. EL.	220uF	+/-10% 10V
C407	061-47303-050	061-47303-050	CAP. PDLT.	2200pF	+/-5% 50V
C410	089-22702-010	089-22702-010	CAP. EL.	220uF	+/-10% 10V
C411	061-47303-050	061-47303-050	CAP. M.C.	0.047uF	+/-5% 50V
C414, C415	011-68101-050	011-68101-050	CAP. PS	680pF	+/-5% 50V
C416, C417	011-15201-050	011-15201-050	CAP. PS	1500pF	+/-5% 50V
C418, C419	011-18201-050	011-18201-050	CAP. PS	1800pF	+/-5% 50V
C420	011-12101-050	011-12101-050	CAP. PS	120pF	+/-5% 50V
C421	011-12101-050	011-12101-050	CAP. PS	120pF	+/-5% 50V
C422, C423	061-47303-050	061-47303-050	CAP. M.C.	0.047uF	+/-5% 50V
C424, C425	089-22702-010	089-22702-010	CAP. EL.	220uF	+/-10% 10V
C426, C427	089-10702-010	089-10702-010	CAP. EL.	100uF	+/-10% 10V
C428	061-47303-050	061-47303-050	CAP. M.C.	0.047uF	+/-5% 50V
C429, C430	089-10201-050	089-10201-050	CAP. MYLAR	0.001uF	+/-5% 50V
C431, C432	011-47101-050	011-47101-050	CAP. PS	470pF	+/-5% 50V
C433, C436	008-22702-016	008-22702-016	CAP. EL.	220uF	+/-10% 16K
C437, C440	088-47301-050	088-47301-050	CAP. MYLAR	0.047uF	+/-5% 50V
C439, C440	089-22602-050	089-22602-050	CAP. EL.	22uF	+/-5% 50V
C441	089-47402-050	089-47402-050	CAP. EL.	0.47uF	+/-10% 50V
C442	010-47702-025	010-47702-025	CAP. EL. AL VENT	470uF	+/-10% 25V
C443-C445	008-22702-016	008-22702-016	CAP. EL.	220uF	+/-10% 16K
C446, C447	089-22702-010	089-22702-010	CAP. EL.	220uF	+/-10% 10V
C448-C451	010-10802-025	010-10802-025	CAP. EL. AL VENT	1000uF	+/-10% 25V
C452	087-22302-100	087-22302-100	CAP. MYLAR	0.022uF	100V
C453, C454	079-10401-100	079-10401-100	CAP. WPP TYPE	0.1uF	100V
C302, C455	004-10303-050	004-10303-050	CAP. CER.	0.01uF	+20-80% 100V
C456, C457	001-10101-050	001-10101-050	CAP. PS	100pF	+/-5% 50V
C501	008-47602-010	008-47602-010	CAP. EL.	47uF	+/-10% 10V
<b>DIODES</b>					
D101, D102	091-00075-005	091-00075-005	ZENER DIODE	7.5V 500mW	1
D103, D104	1N4148	091-34141-01M	D100E	1N4148	1
D105-D108	1N4002	091-04002-01M	D100E	1N4002	1
D109	1N4148	091-04141-01M	D100E	1N4148	1
D300, D301	1N4148	091-04141-01M	D100E	1N4148	1
D403-D408	3N4002	091-04002-01M	D100E	3N4002	1
ZD401	091-00051-005	091-00051-005	ZENER DIODE	5.1V 500mW	1
<b>FUSES</b>					
F401, F402	025-00501-004	025-00501-004	FUSE	250V/0.25A	2
F502, F503	025-01600-009	025-01600-009	FUSE	0.43A/250V	2

## 501 PARTS LIST

SYMBOL NO.	REF. NO.	PART NO.	DESCRIPTION	SPECIFICATION	Q'TY
<b>ICs</b>					
U101	TD48809T	020-08809-TDA	IC.	TD48809T	1
U102	TD48809T	020-08809-TDA	IC.	TD48809T	1
U103	TD40372/OP2	020-00372-TDA	IC.	TD40372/OP2	1
U104	8AA560	020-04560-DBA	IC.	8AA560 JRC.	1
U105	8AA73100P	020-07310-SAA	IC.	8AA73100P	1
U106	MN4264P-15	020-04264-DMN	IC.	MN4264P-15	1
U107	ZC79696P	020-99696-DZC	IC.	ZC79696P	1
U110	NJ47410	020-00741-NJM	IC.	NJ47410	1
U111, IC406	UPC7805M	020-07805-UPC	VOLTAGE REG IC.	UPC7805M +5V/1A	2
U112	NJ479M05	020-79M05-NJM	VOLTAGE REG IC.	NJ479M05 -5V/0.5A	1
IC401	8AA73230P	020-07323-SAA	IC.	8AA73230P	1
IC403	NE5532N	020-05532-ONE	IC.	NE5532N	2
IC404	UPC7805M	020-78M05-UPC	VOLTAGE REG IC.	UPC7805M +15V/0.5A	1
IC405	NJ479M15	020-79M15-NJM	VOLTAGE REG IC.	NJ479M15 -15V/0.5A	1
IC501	MN4533	020-05433-DMN	IC.	MN4533	1
<b>TRANSISTORS</b>					
T101, T102	8C338-25	090-00338-025	TRANSISTOR	8C338-25	2
T103	8C328-25	090-00328-025	TRANSISTOR	8C328-25	1
T104, T105	8C358-B	090-00358-002	TRANSISTOR	8C358-B	2
T301	8C328-25	090-00328-025	TRANSISTOR	8C328-25	1
T302	8C338-25	090-00338-025	TRANSISTOR	8C338-25	1
Q401, Q402	8C5468	021-00546-002	TRANSISTOR	8C5468	2
Q403	8C5468C	021-00546-007	TRANSISTOR	8C5468C	2
Q404, Q405	8C5468	021-00546-002	TRANSISTOR	8C5468	2
Q501	28A733P	021-00733-016	TRANSISTOR	28A733P	1
<b>RESISTORS</b>					
R104	095-52101-003	095-52101-003	RES. FUSE	10J +/-5% 1/3W	1
R105, R116, R118	095-52470-003	095-52470-003	RES. FUSE	4, 7J +/-5% 1/3W	3
R125	095-52121-003	095-52121-003	RES. FUSE	12J +/-5% 1/3W	1
R127	017-2030B-301	017-2030B-301	RES. SEMI-FIX	2K BF 3P	1
R129	095-52181-003	095-52181-003	RES. FUSE	18J +/-5% 1/3W	1
R133	095-52101-003	095-52101-003	RES. FUSE	10J +/-5% 1/3W	1
R141	095-52470-003	095-52470-003	RES. FUSE	4, 7J +/-5% 1/3W	1
R144	095-52101-003	095-52101-003	RES. FUSE	10J +/-5% 1/3W	1
R154	095-52470-003	095-52470-003	RES. FUSE	4, 7KJ +/-5% 1/3W	1
R168, R169	095-52101-003	095-52101-003	RES. FUSE	10J +/-5% 1/3W	2
R190, R191	095-52470-003	095-52470-003	RES. FUSE	4, 7J +/-5% 1/3W	2
R305, R306	095-52101-003	095-52101-003	RES. FUSE	10J +/-5% 1/3W	2
R425-R426	080-52653-F08	080-52653-F08	RES. METAL FILM	6, 49KJ +/-2% 1/8W	4
R445	080-90561-010	080-90561-010	RES. METAL OXIDE	56J +/-5% 1W	1
<b>SWITCHES</b>					
W101	023-00425-001	023-00425-001	TACT SWITCH	8KH482510	1
T8501-T8511	023-00425-001	023-00425-001	TACT SWITCH	8KH482510	11
P6401	023-07150-004	023-07150-004	POWER SWITCH	8DL18P 18501-511 1017U-EP	1
<b>OTHERS</b>					
CT401	035-82896-011	035-82896-011	CRYSTAL	11.2896MHZ HC-49/U	1
NJ401	027-02602-002	027-02602-002	RCA JACK	RJ-1020-010	1
L401	019-00210-003	019-00210-003	CHOKO COIL	4, 7UH +/-10%	1
LC501	025-00501-001	025-00501-001	LCD DISPLAY	UTM-W065EMV	1
LP501, LP502	025-00501-003	025-00501-003	AMP	65MA/16V 4, 75H	2
PT501	048-00501-001	048-00501-001	TRANSFORMER	E1-57	1
XT02	016-00006-TDK	016-00006-TDK	CERAMIC FILTER	TDK OMC3	1

# PACKING DIAGRAM

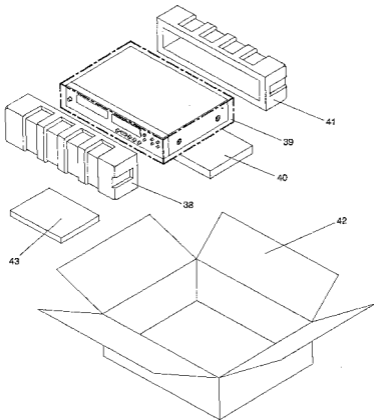

ITEM	PARTS NO.	DESCRIPTION	QTY
38	137-00501-002	POLYFOAM F	1
39	138-00501-001	PE BAG	1
40	137-00501-003	POLYFOAM A	1
41	137-00501-001	POLYFOAM R	1
42	141-00501-001	CARTON	1
43	134-00501-001	INSTRUCTION MANUAL	1

## NOTES:

Proprietary information for servicing purposes only.

The information herein may not be used commercially without the prior written agreement of NAD Electronics Ltd, London, England.

# SERVICE MANUAL

© NAD 1993 PRINTED IN USA

**501**  
**COMPACT DISC**  
**PLAYER**

**NAD ELECTRONICS LTD**  
LONDON