

36596

# SERVICE MANUAL

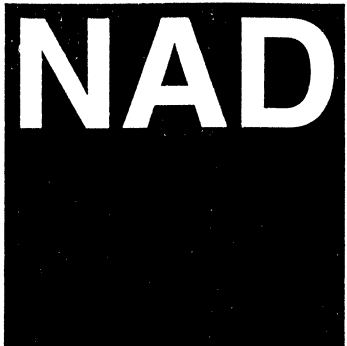

**522**  
COMPACT  
DISC PLAYER

**522**  
COMPACT  
DISC PLAYER

## SAFETY INFORMATION

### CAUTION

**CAUTION** - INVISIBLE LASER RADIATION WHEN OPEN AND INTERLOCKS DEFEATED. AVOID EXPOSURE TO BEAM.  
**ADVARSEL** - USYNLIG LASERSTRÅLING NÅR DEKSEL ÅPNEES OG SIKKERHEDSILÅS BRYTES. UNNGÅ EKSPONERING FOR STRÅLEN.  
**ADVARSEL** - USYNLIG LASERSTRÅLING VED ÅBNING, NÅR SIKKERHEDSAFBRYDERE ER UDE AF FUNKTION. UNDGÅ UDSÆTTELSE FOR STRÅLING.  
**VARNING** - OSYNLIG LASERSTRÅLING NÅR DENNA DEL ÅR ÖPNAD OCH SPÄRRAR ÅR URKOPPLADE. STRÅLEN ÅR FARLIG.  
**VARO!** - AVATTAESSA JA SUOJALUKITUS OHITETTAESSA OLET ALLTINA NÄKTMÄTÖNTÄ LASERSÄTEILYLLE. ÄLÄ KAISO SÄTEESEEN.  
**VORSICHT!** - UNSICHTBARE LASERTRAILUNG TRITT AUS, WENN DECKEL GEÖFFNET UND WENN SICHERHEITSVERRIEGELUNG ÜBERBRÜCKT IST. NICHT DEM STRAHL AUSSETZEN.

**CLASS 1  
LASER PRODUCT**

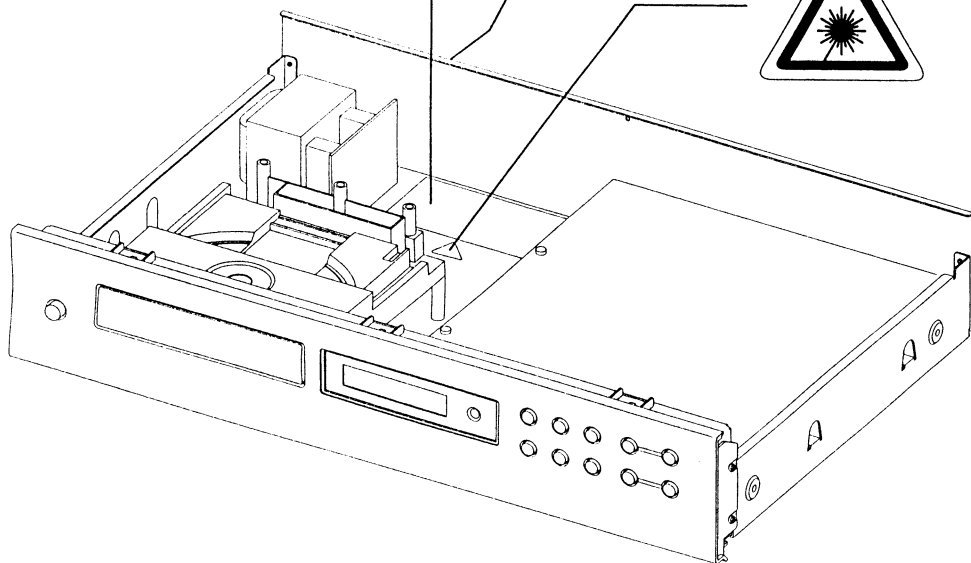

The lightning flash with arrowhead, within an equilateral triangle is intended to alert the user of the presence of uninsulated "dangerous voltage" within the product's enclosure; that may be of sufficient magnitude to constitute a risk of electric shock to persons.



The exclamation point within an equilateral triangle is intended to alert the user of the presence of important operating and maintenance (servicing) instructions in the literature accompanying the appliance.

THIS DEVICE COMPLIES WITH PART 15 OF THE FCC RULES. OPERATION IS SUBJECT TO THE FOLLOWING TWO CONDITIONS :-  
 (1) THIS DEVICE MAY NOT CAUSE HARMFUL INTERFERENCE, AND  
 (2) THIS DEVICE MUST ACCEPT ANY INTERFERENCE RECEIVED, INCLUDING INTERFERENCE THAT MAY CAUSE UNDESIRABLE OPERATION.

## SERVICE SAFETY PRECAUTIONS

### 1. Replacing the fuses

**CAUTION:** FOR CONTINUED PROTECTION AGAINST THE RISK OF FIRE REPLACE ONLY WITH SAME TYPE OF FUSE.

Reference No	Part Number	Description
M801*AH	5120-0031-0	Fuse 500mA 250V Time Lag High Surge (UL/CSA)
M801*B,*B1,*C	5120-0057-0	Fuse 125mA 250V Time Lag (SEMKO/VDE)

#### NOTE :

- <\*AH > : USA, CANADIAN MODEL ONLY.
- <\*B > : UK MODEL ONLY.
- <\*B1 > : AUSTRALIAN MODEL ONLY.
- <\*C > : EUROPEAN MODEL ONLY.

### 2. Safety check out

(Only U.S.A. model)

Before returning the product to the customer, make leakage current or resistance measurements to determine that exposed parts are acceptably insulated from the supply circuit.

Parts marked with the symbol are critical with regard to the risk of fire and electric shock. Replace only with parts recommended by the manufacturer.

## CONTENTS

DESCRIPTION	PAGE
SPECIFICATIONS .....	4
REAR PANEL / FRONT PANEL VIEW .....	5
BLOCK DIAGRAM .....	6
WIRING DIAGRAM .....	7
DISASSEMBLY INSTRUCTIONS .....	15
RF PATTERN TESTING .....	16
IMPORTANT NOTES .....	8 - 9
PCB LAYOUT .....	10 - 12
SCHEMATIC DIAGRAM .....	13 - 14
IC BLOCK DIAGRAM .....	17 - 20
TROUBLESHOOTING GUIDE .....	21
EXPLODED VIEW .....	22
EXPLODED VIEW PARTS LIST .....	23
MECHANISM EXPLODED VIEW .....	24 - 25
ELECTRICAL PARTS LIST .....	26 - 28
PACKING DIAGRAM .....	29

## SPECIFICATIONS

Disc Capacity .....	One Disc, 120 or 80 mm
Decoding .....	BURR-BROWN Delta Sigma
Digital Filter .....	8 Times oversample
Analog Filter .....	4 pole active
Frequency Response .....	+/- 0.5 dB, 5 Hz - 20 kHz
De-Emphasis Error .....	+/- 0.3 dB
THD (at 0 dB, 1 kHz) .....	0.007%
Intermodulation Distortion .....	< -100 dB
(19 + 20 kHz)	
Dynamic Range .....	96 dB
Linearity .....	+/- 0.5 dB, 0 dB to -80 dB
Signal / Noise Ratio (A-Weighted) .....	102 dB, De-Emphasis on
	102 dB, De-Emphasis off
Channel Separation 1 kHz .....	> 90 dB
10 kHz .....	> 80 dB
Wow and Flutter .....	Unmeasurable (Quartz Crystal Accuracy)
Output Impedance .....	200 Ω
Output level at 0 dB .....	2.0 V rms
Digital Error Correction .....	CIRC with double error correction
	in C1 and C2

## CONTROLS

Play / Pause, Stop, Random, Skip (< >), Scan (< >), Open, Time, Repeat.

## PHYSICAL SPECIFICATIONS

Dimensions (Width x Height x Depth)	435 x 80 x 285 mm
Net weight	4 kg (8.8 lbs)
Shipping weight	5.1 kg (11.22 lbs)

## REAR PANEL / FRONT PANEL VIEW

### REAR PANEL

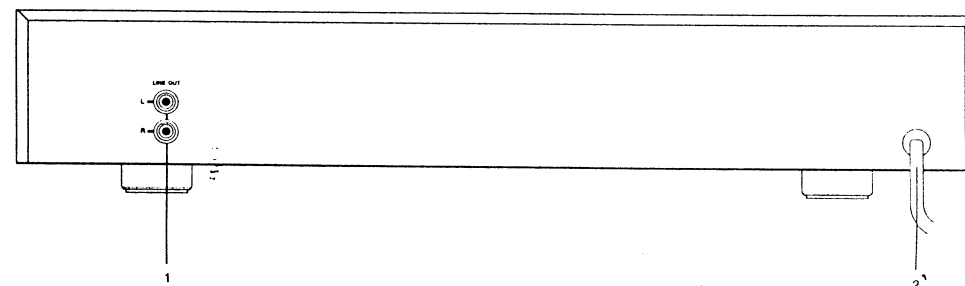

1. LINE OUTPUT

2. AC LINE CORD

### FRONT PANEL

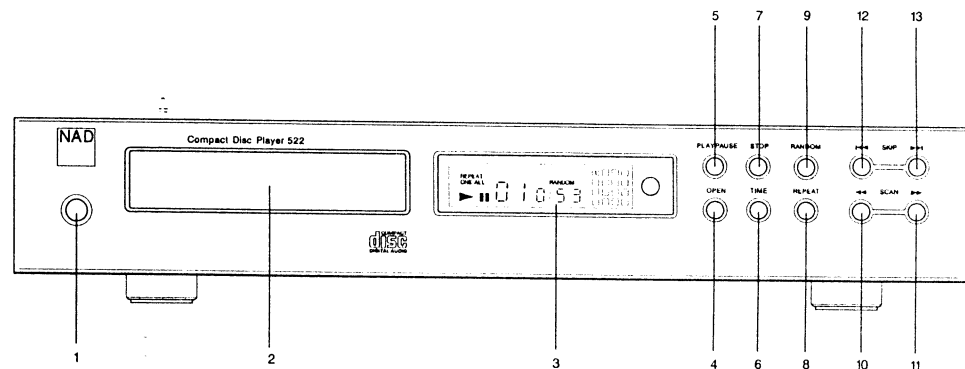

1. POWER ON / OFF
2. DISC DRAWER
3. DISPLAY
4. OPEN
5. PLAY / PAUSE
6. TIME
7. STOP

8. REPEAT
9. RANDOM
10. SCAN Back ( ◀◀ )
11. SCAN Forward ( ▶▶ )
12. SKIP Back ( ◀◀◀ )
13. SKIP Forward ( ▶▶▶ )

# BLOCK DIAGRAM

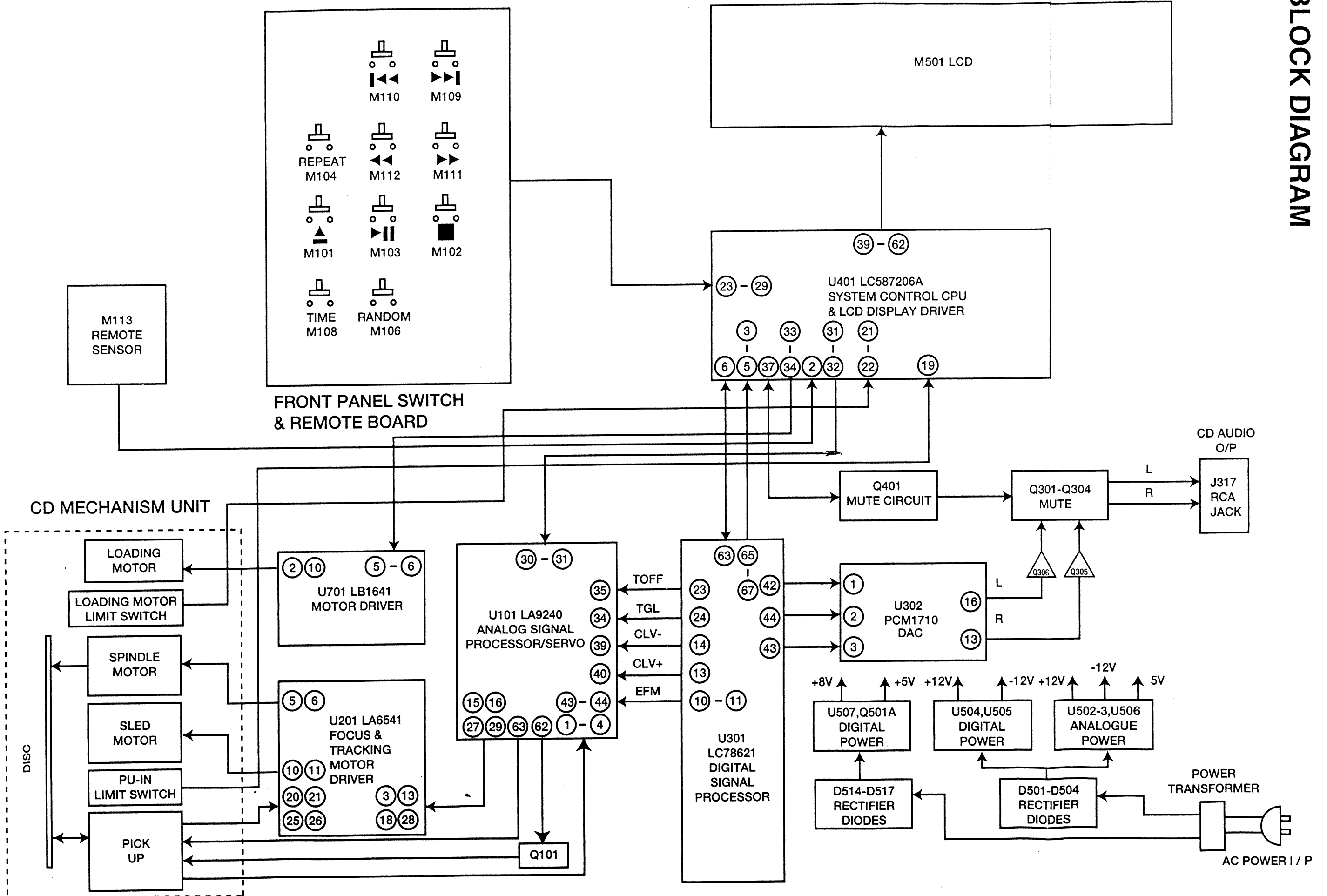

# WIRING DIAGRAM

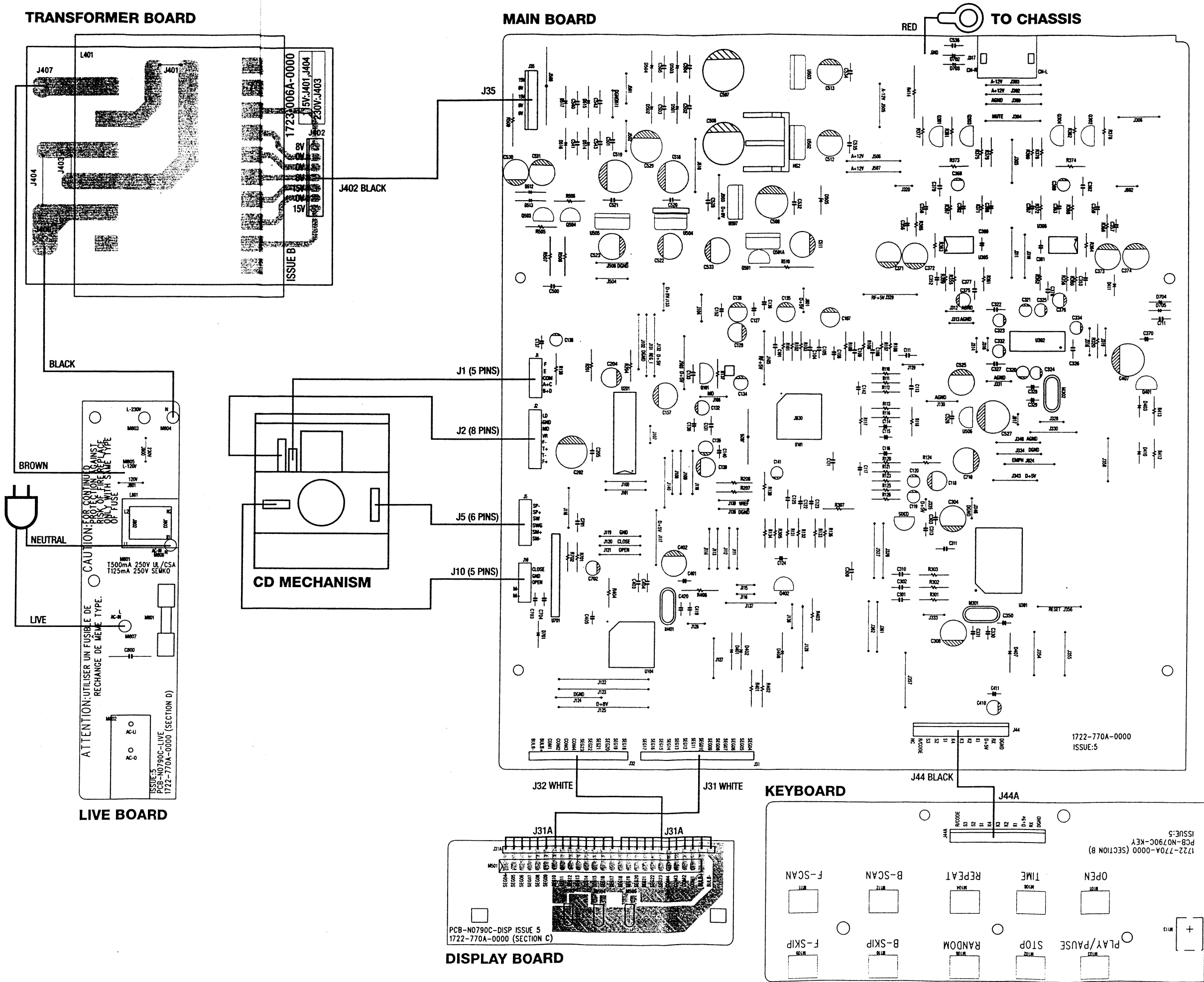

## IMPORTANT NOTES

### INSTRUCTION FOR HANDLING OPTICAL SYSTEM BLOCK PICK-UP

Electrostatic breakdown of the laser diode in the optical system block may occur due to a potential difference caused by electrostatic charge accumulated on clothing, human body, etc. A ground must be provided as follows to prevent any electrostatic charge during unpacking or repair work.

#### 1. Ground for Human Body

Be sure to wear a ground band (1M ohm) that is properly grounded to remove any static electricity that may be charged on the body.

#### 2. Ground for Work Bench

Be sure to place a conductive sheet (1M ohm) or copper plate with proper grounding on the work bench or other surface on which the pick-up is to be placed.

3. Because the static electricity charge on the clothing does not discharge through the body grounding band, do not let clothing to get in contact with the pick-up unit.

#### INCORRECT



#### CORRECT

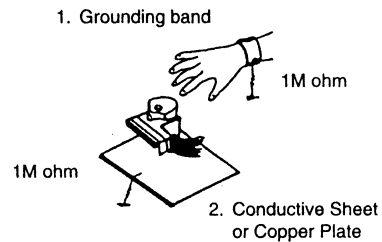

**NOTE:** Laser diodes are so susceptible to damage from static electricity that even if a static discharge does not ruin the diode, it can shorten its life or cause it to work improperly.

### PRECAUTIONS FOR CHECKING BEAM EMISSION

The laser beam of this unit is focused on the reflecting surface of the objective lens in the optical system block. Therefore, keep your eyes at least 12 inches (30 cm) away from the objective lens when the laser diode is **ON**.

(Operation Check Method for Laser Diode and Focus Search Function.)

When the **POWER** switch is turned **ON** after the chucking plate is removed, observe the objective lens and confirm that the following operations are performed properly.

(The optical system block should be at the lead-in area position when it is checked at this time.)

- (1) The laser should be at the innermost position after the chucking plate is removed.
- (2) The diffused light of the laser beam can be seen when the **POWER** switch is turned **ON**.
- (3) Vertical (up and down) movement of the objective lens (2 or 3 times) will take place.

### PRECAUTIONS WHEN CHANGING LASER PICK-UP

When removing the pick-up assembly, short circuit the PCB tracks on the optical block as shown in the drawing in order to protect the pick-up before removal.

**NOTE:** Replacement pickup assemblies are supplied with the PCB pattern already protected.

**DO NOT REMOVE THE SHORT CIRCUITS UNTIL YOU HAVE FINISHED FITTING THE PICK-UP.**

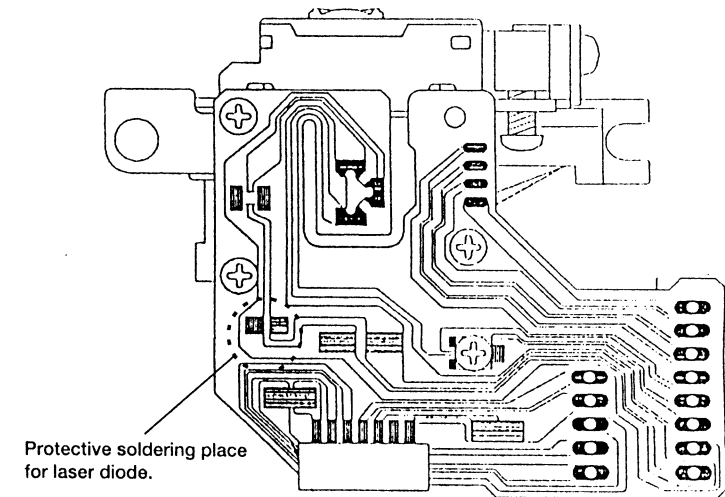

#### Caution:

Laser diodes are extremely susceptible to damage from static electricity. Even if a static discharge does not ruin the diode, it can shorten its life or cause it to work improperly. When replacing the pick-up, use a conductive mat, a grounded soldering iron, and so on, to protect the laser diode from static damage.

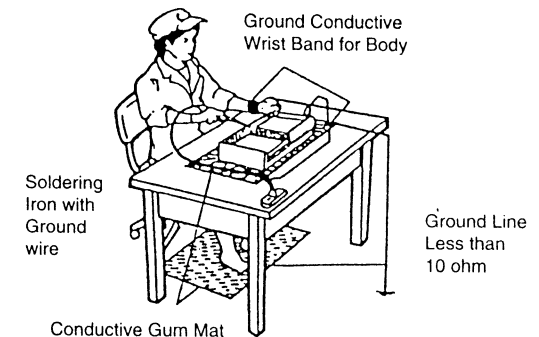

# PCB LAYOUT

## TRANSFORMER BOARD

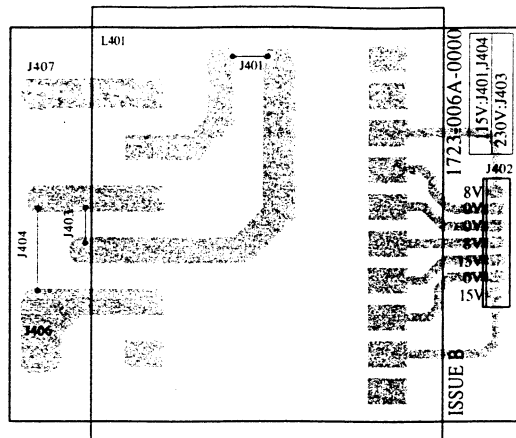

## LIVE BOARD

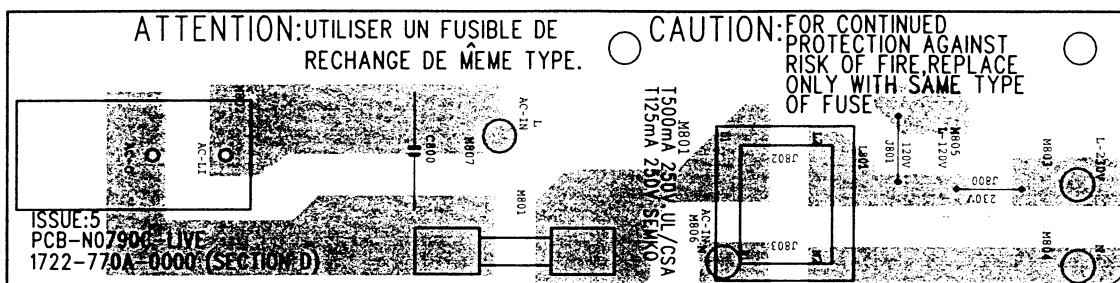

## KEYBOARD

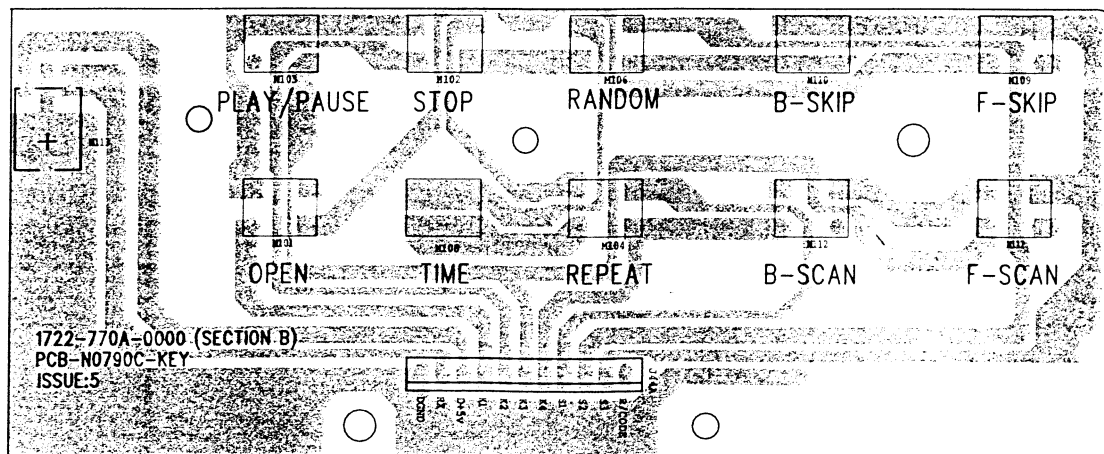

## DISPLAY BOARD

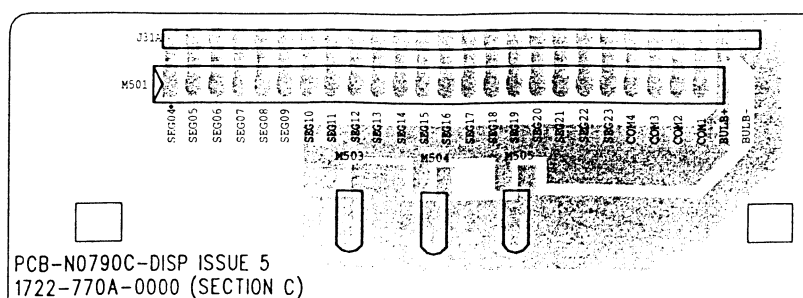

MAIN BOARD

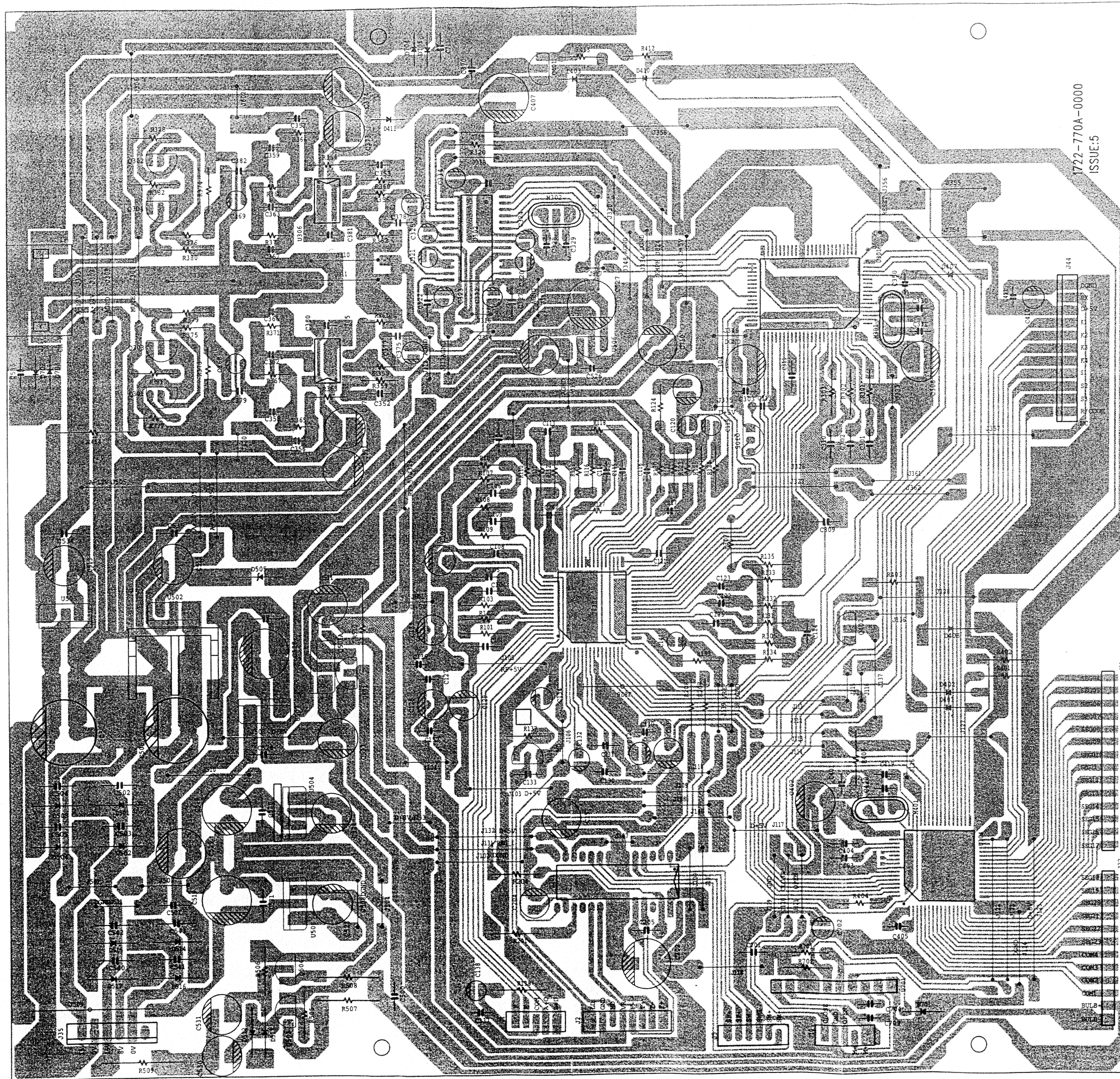

1722-770A-0000  
ISSUE:5



# SCHEMATIC DIAGRAM

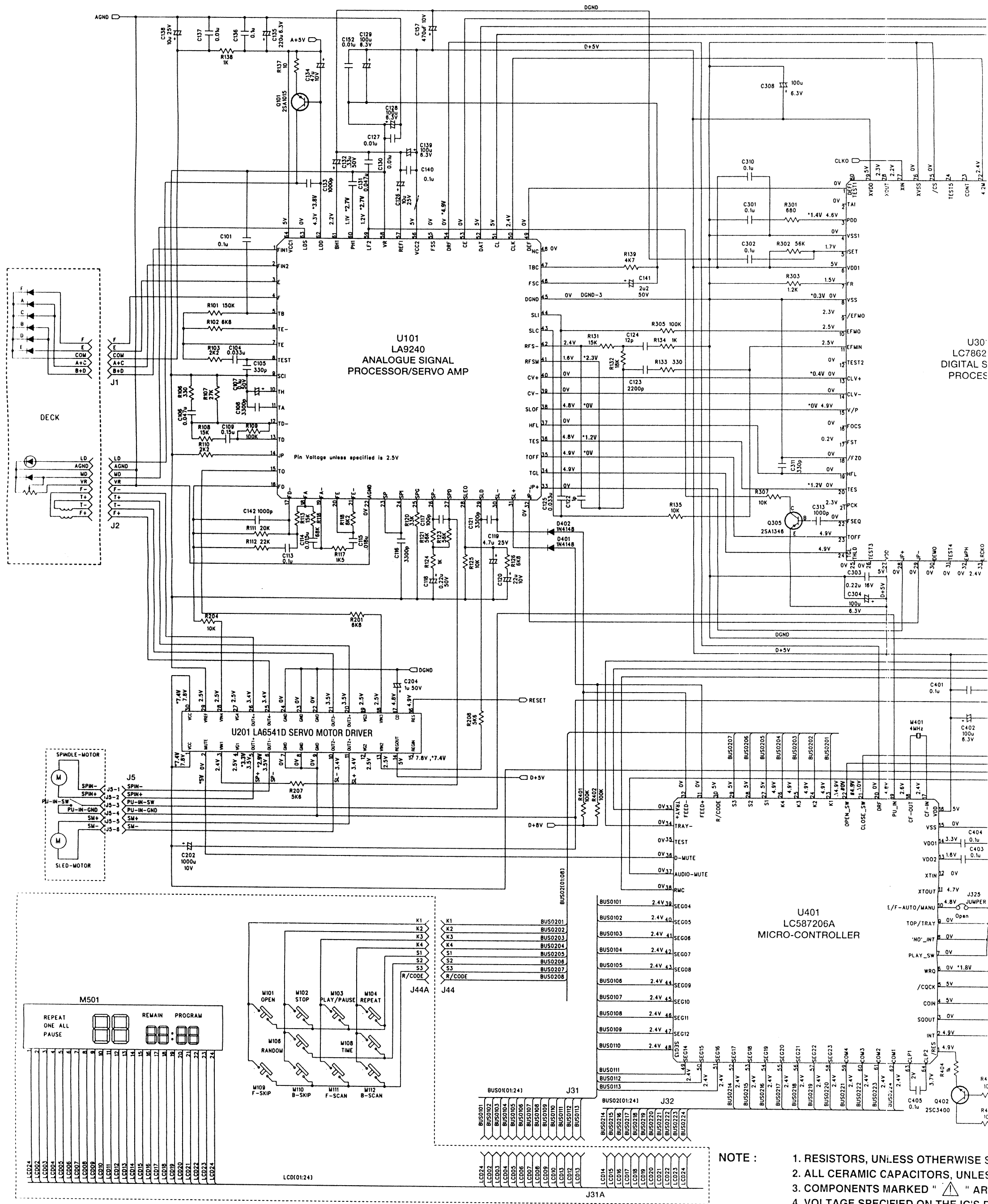

- NOTE :
1. RESISTORS, UNLESS OTHERWISE SPECIFIED
  2. ALL CERAMIC CAPACITORS, UNLESS OTHERWISE SPECIFIED
  3. COMPONENTS MARKED " " ARE TO BE USED
  4. VOLTAGE SPECIFIED ON THE IC'S PINS IS IN PLAY MODE, MARKED WITH "+" IS PLAY MODE TRAY CLOSE MODE.

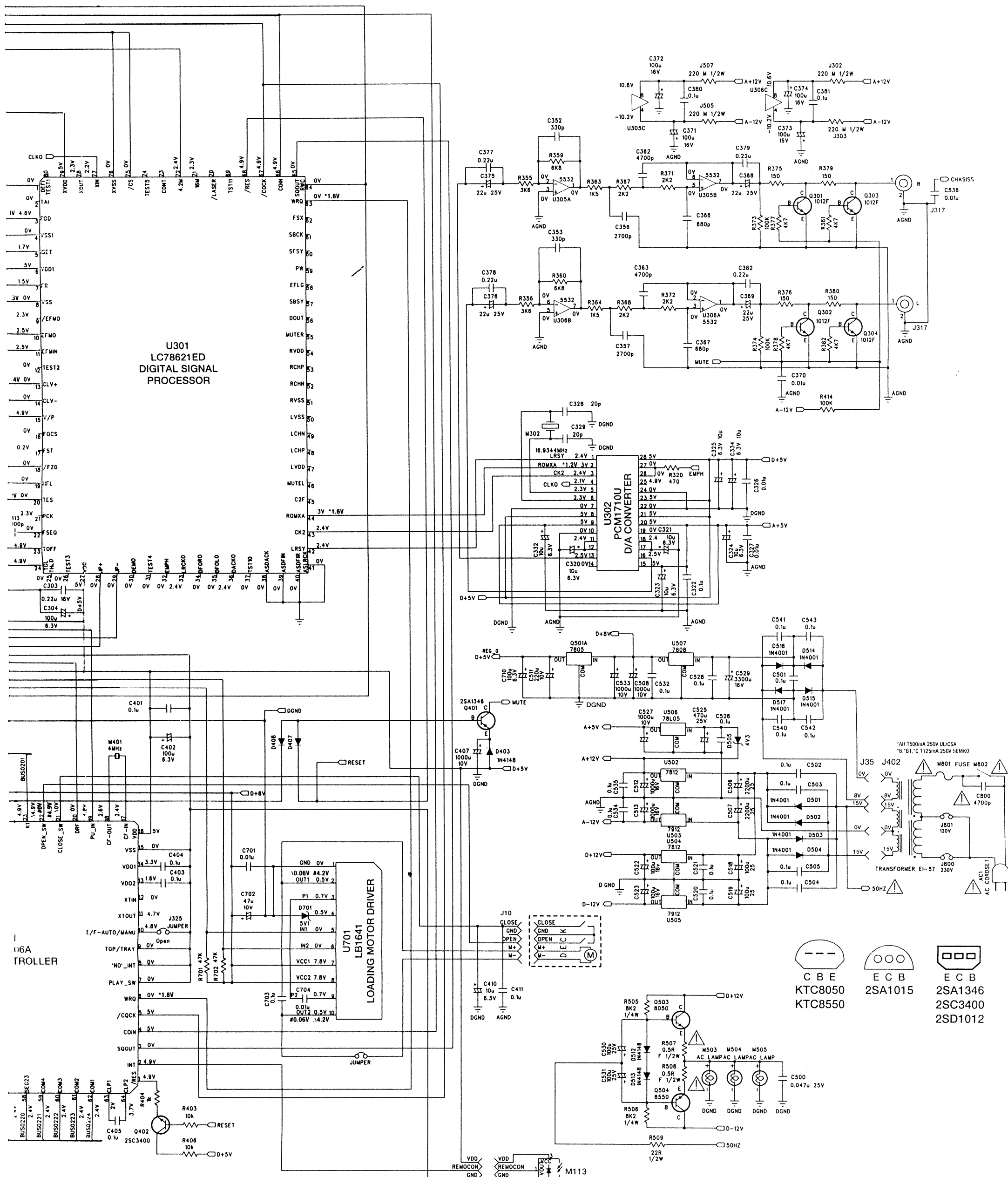

U301  
LC78621ED  
DIGITAL SIGNAL  
PROCESSOR

U302  
PCM1710U  
D/A CONVERTER

U701  
LB1641  
LOADING MOTOR DRIVER

RESISTORS, UNLESS OTHERWISE SPECIFIED, ARE 1/4 WATT.  
 CERAMIC CAPACITORS, UNLESS OTHERWISE SPECIFIED, ARE 50V, 10%.  
 COMPONENTS MARKED "▲" ARE SAFETY CRITICAL PARTS.  
 VOLTAGE SPECIFIED ON THE IC'S PIN WHICH DO NOT HAS MARKING IS IN STOP  
 MODE, MARKED WITH "." IS PLAY MODE, "#" IS TRAY OPEN MODE AND "Δ" IS  
 TRAY CLOSE MODE.

RESISTORS : M - METAL FILM  
 F - FUSIBLE  
 CARBON FILM UNLESS OTHERWISE SPECIFIED.

## DISASSEMBLY INSTRUCTIONS

1. Remove machine screws M 4.0 x 6.0 ( ① to ④ ) from the side panels.  
Remove tapping screw 3.0 x 8.0 ( ⑤ ) from the back panel.  
Refer to **Figure No. 1**.

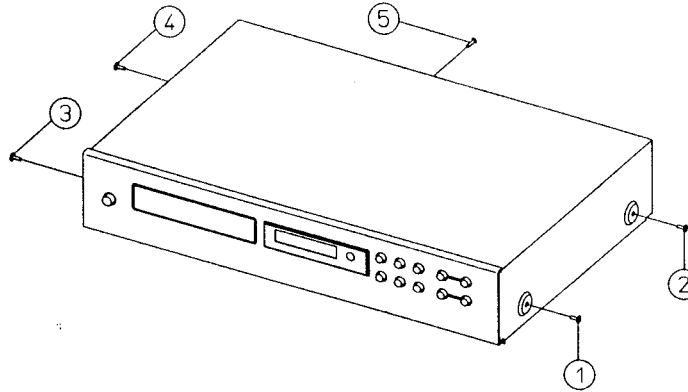

Figure No. 1.

2. Pull both sides of the TOP COVER slightly outwards ( ⑥ ) and tilt approx. 35° and then remove in the direction as indicated by the arrow ( ⑦ ). Refer to **Figure No. 2**.

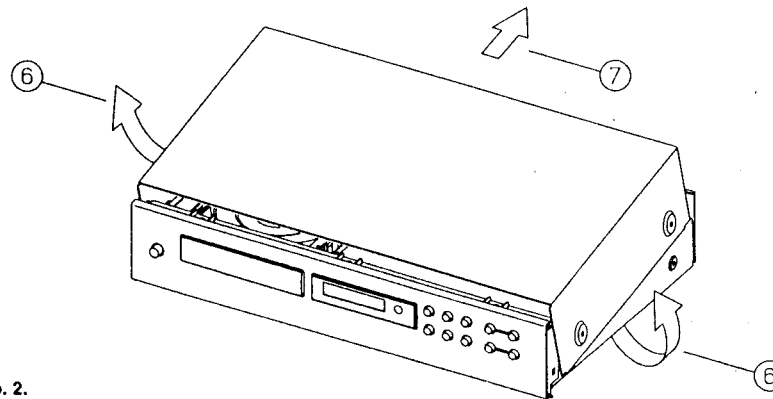
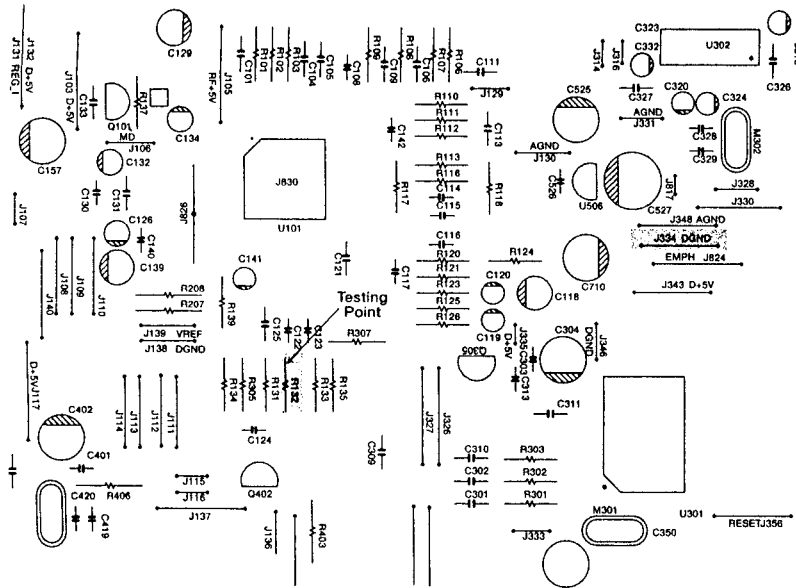

Figure No. 2.

# RF PATTERN TESTING

# IC BLOCK DIAGRAM

U101: LA9240M



NAD - 522 PCB TESTING POINTS DIAGRAM

## TESTING PROCEDURE

- Load the test disc and set the unit into PLAY mode.
- Connect the scope to R132 (Pin 41 of U101) and DGND (J334).  
Scope setting: Coupling : AC.  
Vertical sensitivity : 0.2 V/div.  
Horizontal time base : 0.5 μS/div.
- Observe the waveform is 2.4V p-p +/- 5% and the eye pattern is at its best shape (see FIG. 1).

FIG. 1 (a)

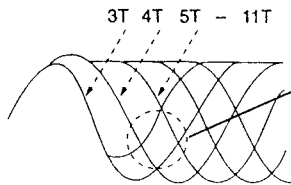

FIG. 1 (b) Poor eye pattern

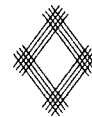
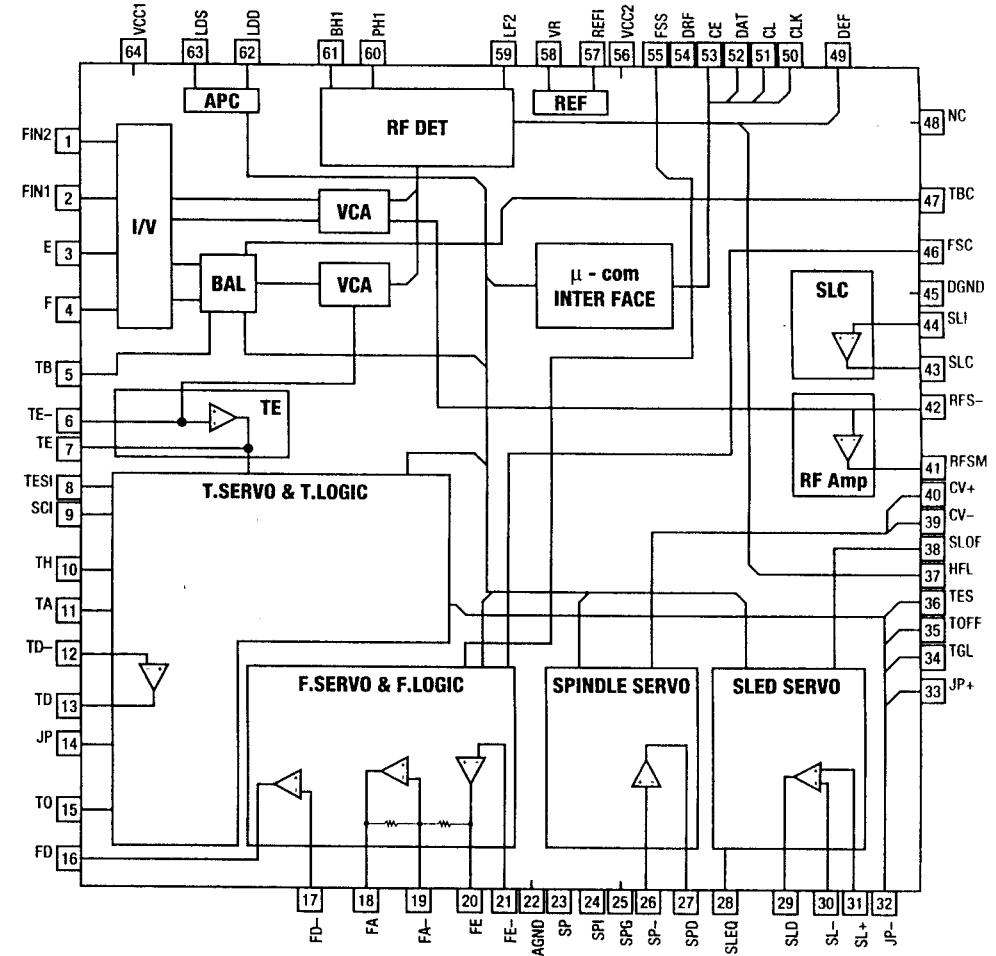
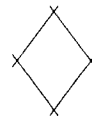
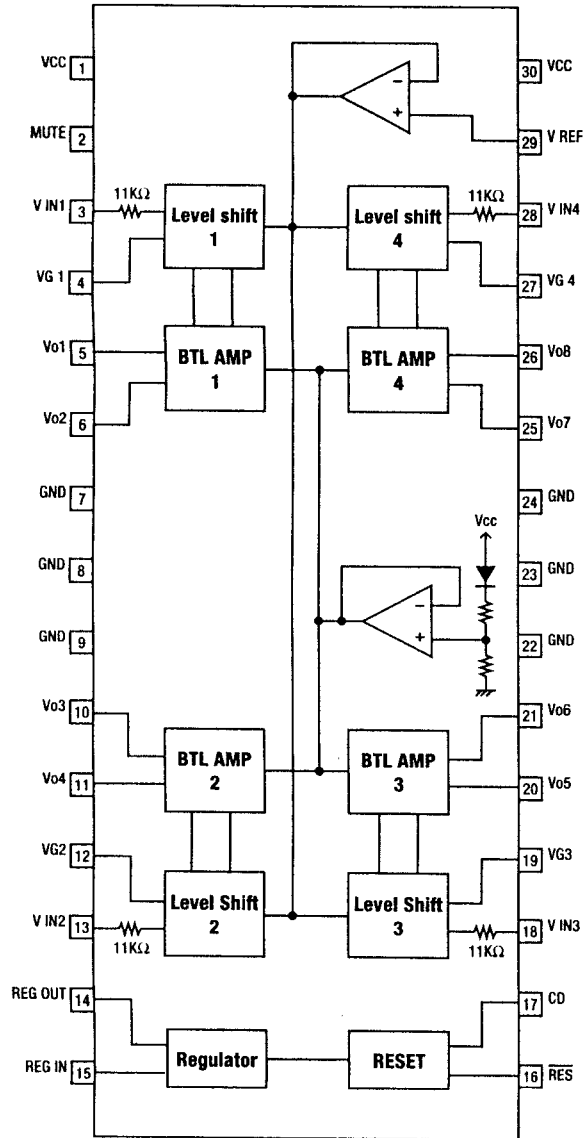

FIG. 1 (c) Good eye pattern



U201: LA6541D



U301: LC78621E - Equivalent Circuit Block Diagram

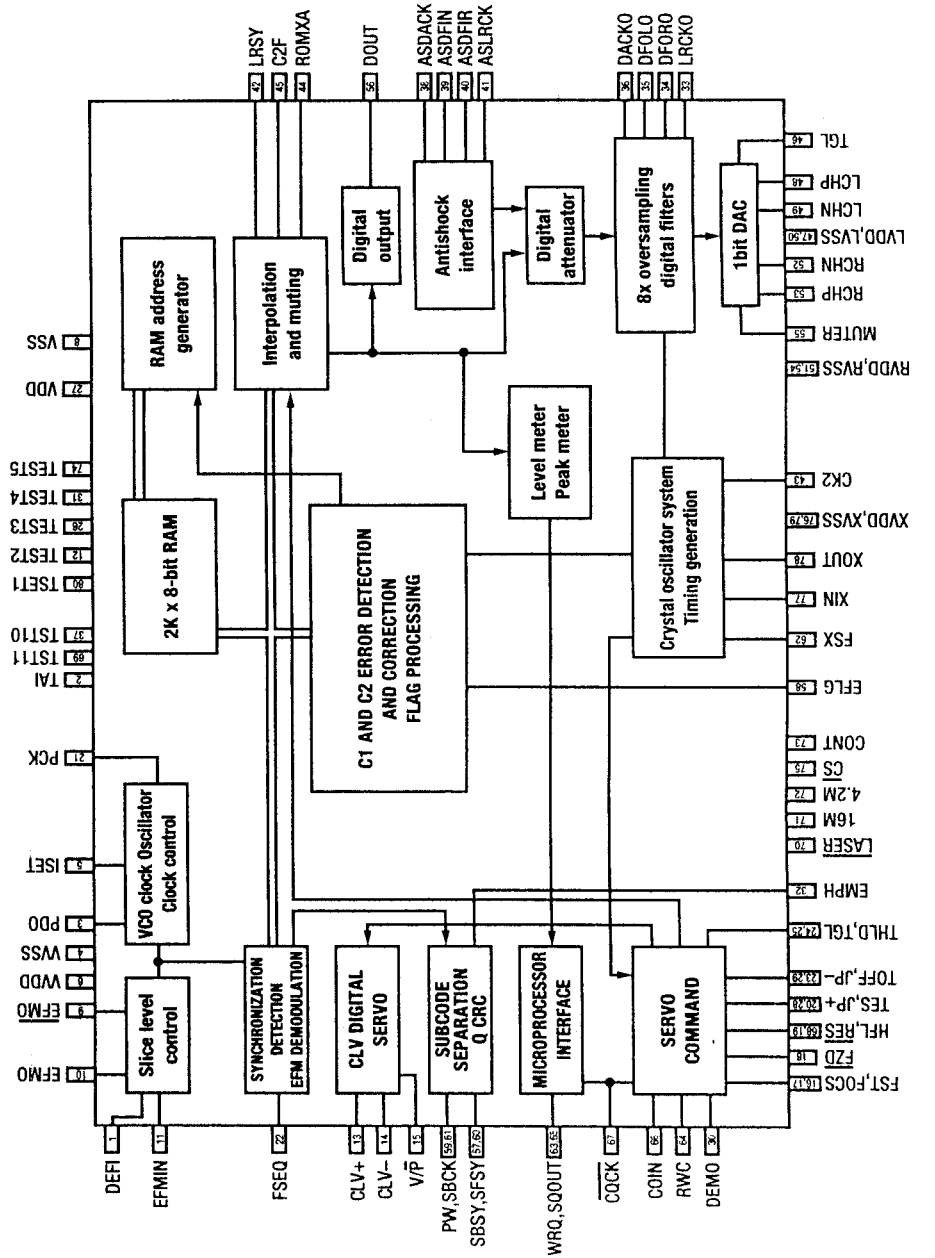

U302: PCM1710U

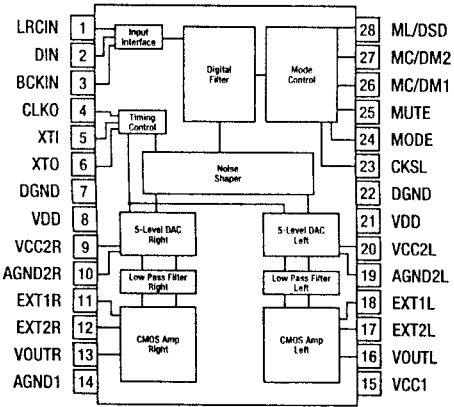

U305 - U306: NE5532

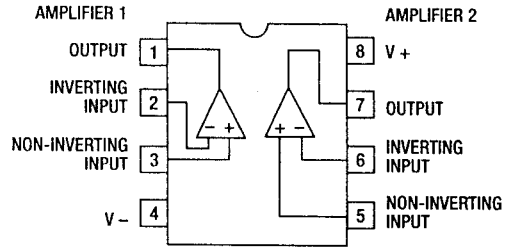

U401: LC587206A

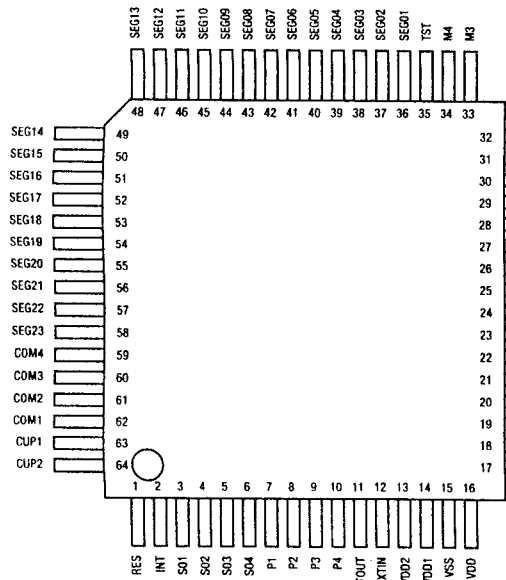

U701: LB1641

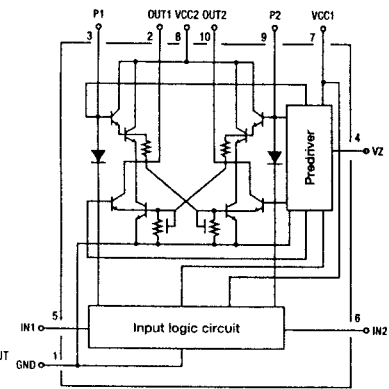

## TROUBLESHOOTING GUIDE

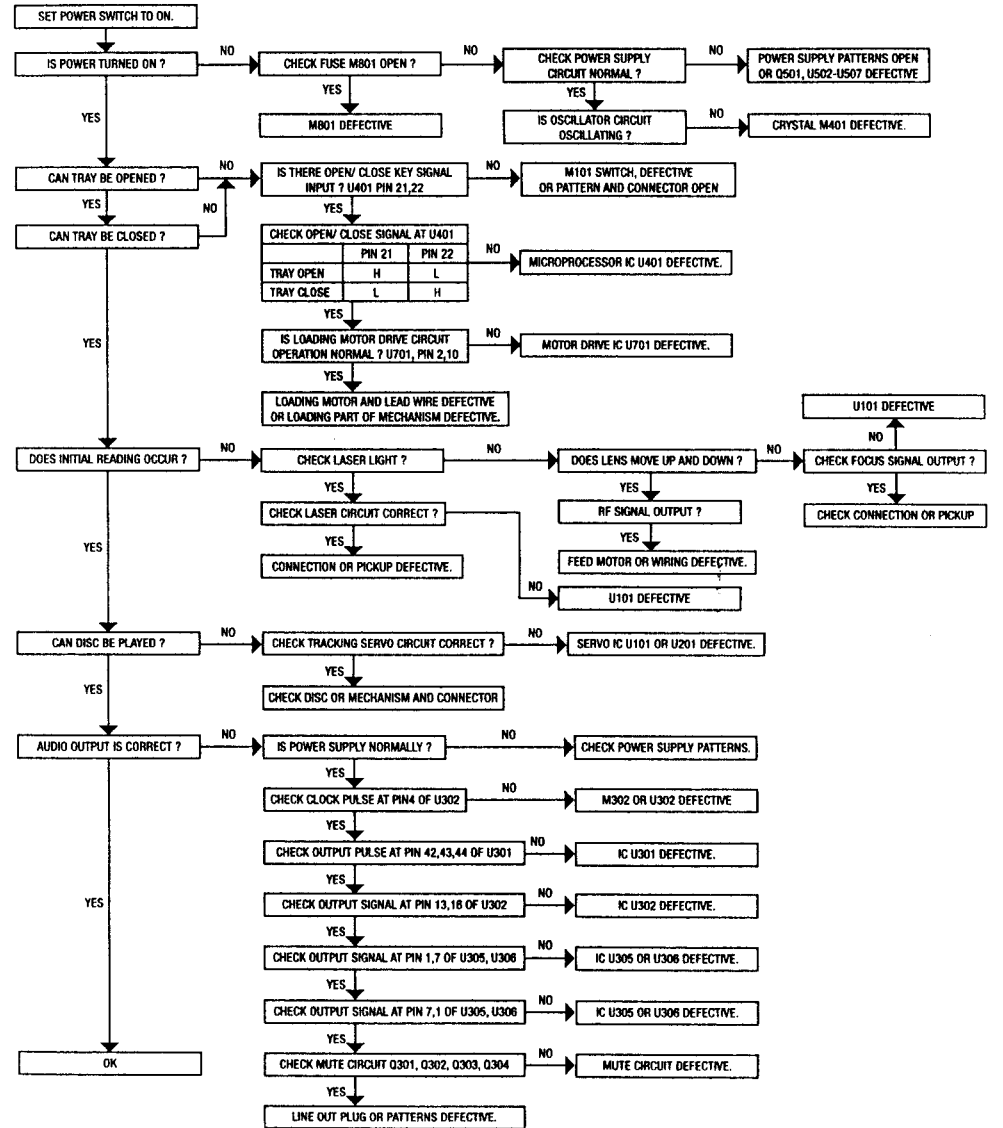

# EXPLODED VIEW

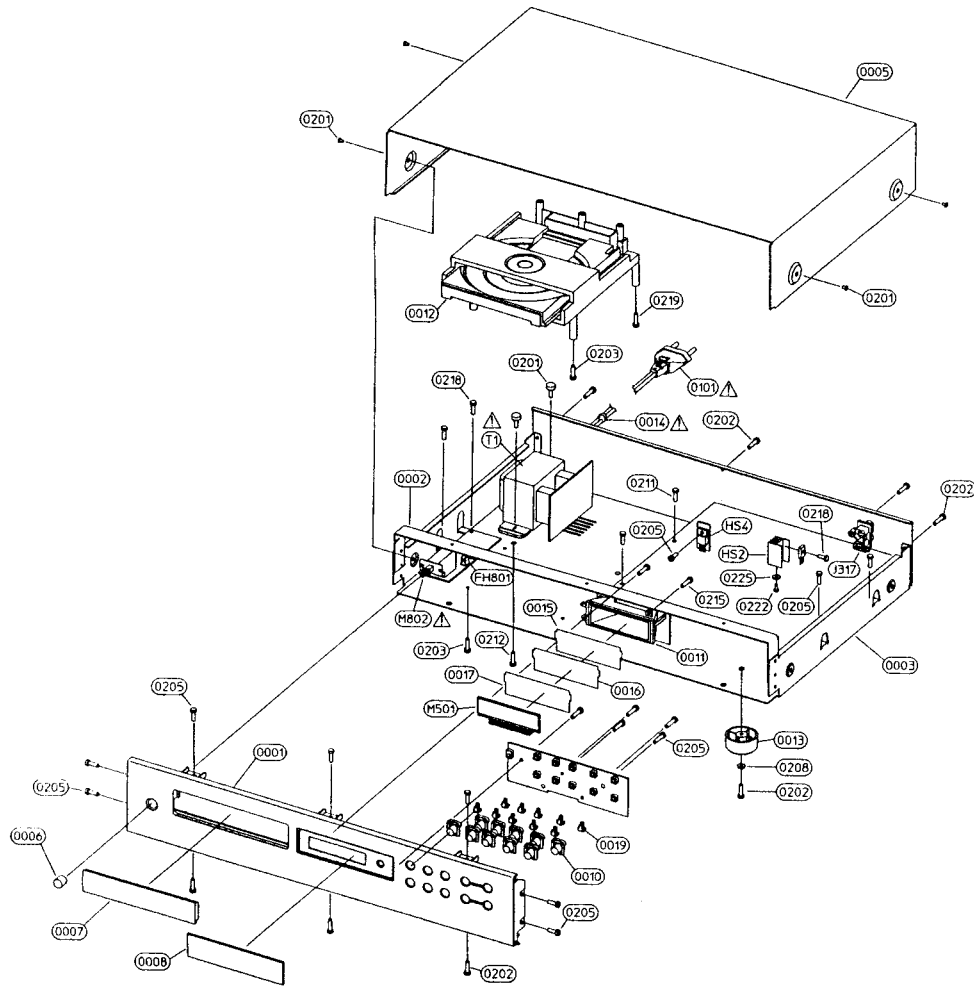

# EXPLODED VIEW PARTS LIST

Item	Part No	Description	Qty
0001	1464-4611-2	FASCIA W/SS-PAINT	1
0002	1402-3781-1	STRAP	1
0003*AH	1402-3507-2	CHASSIS W/SS-PAINT	1
0003*B,*B1,*C	1402-3510-2	CHASSIS W/SS-PAINT	1
0005	1402-3530-0	COVER	1
0006	2437-510B-0	DIA 9.5 GLOSS POWER BUTTON	1
0007	1464-6711-0	CD DOOR	1
0008	3714-6012-0	DISPLAY WINDOW W/SS	1
0010	2437-7301-0	SINGLE BUTTON	10
0011	1464-470B-1	LIGHTBOX	1
0012	4111-0901-1	CD DECK CD93F8	1
0013	4151-9371-1	RUBBER FOOT 14.8MM HIGH	4
0014	4151-9461-0	STRAIN RELIEF BUSHING	1
0015	3715-3806-0	FILTER LIGHTBOX CLEAR	1
0016	3715-390B-0	FILTER LIGHTBOX LF202	2
0017	3715-400B-0	FILTER LIGHTBOX LF217	2
0019	3715-1606-0	BUTTON INSERT	10
0101*AH	7009-3100-1	AC CORD 18AWGX2 SPT-2 UL/CSA	1
0101*B	7009-5110-1	AC CORD ASTA BS1363 W/3A FUSE	1
0101*B1	7009-1190-1	AC CORD SAA AS3112	1
0101*C	7009-3110-0	AC CORD SEMKO	1
0201	2900-4006-3010	M4X0.5PX6MM W/FLAT WASHER	6
0202	2954-3008-3000	TAPPING SCREW 3X8MM (BLK.ZN)	11
0203	2954-3010-3000	TAPPING SCREW 3X10MM (BLK.ZN)	2
0205	2954-3008-0000	TAPPING SCREW 3X8MM (YEL.ZN)	15
0208	2842-3367-0	METAL WASHER ID=3.3 OD=6.7	4
0211	2904-3006-0000	SCREW M3X6 (YEL.ZN)	2
0212	2954-3510-3000	TAPPING SCREW 3.5X10MM (BLK.ZN)	1
0215	2950-3008-0000	TAPPING SCREW 3X8MM PH (YEL.ZN)	2
0218	2954-3006-0000	TAPPING SCREW 3X6MM (YEL.ZN)	3
0219	2954-4010-3000	TAPPING SCREW 4X10MM (BLK.ZN)	1
0222	2954-2606-0000	TAPPING SCREW 2.6X6MM (YEL.ZN)	1
0225	2601-2608-0601	FIBRE WASHER M2.6 0.8T OD=6	1
HS2	5400-0831-0	HEATSINK 20MM-HIGH HOLE	1
HS4	5400-1051-0	HEATSINK PLATE 28X12X2T	1
J317	2103-9202-0	2P RCA R/W (GOLD PLATE)	1
M501	2460-1340-1	LCD DISPLAY NEGATIVE	1
FH801	4131-9131-0	FUSE HOLDER 6.5MM PITCH RECT	2
M802	5200-0961-0-01	POWER SWITCH	1
T1	1806-2194-0	EI-57 TRANSFORMER	1

NOTE : - The components identified by  $\Delta$  mark are critical for risk of fire and electrical shock. Replace only with part number specified.

- <\*AH> : USA, Canadian model only.
- <\*B> : UK model only.
- <\*B1> : Australian model only.
- <\*C> : European model only.

# MECHANISM EXPLODED VIEW

CD93F8

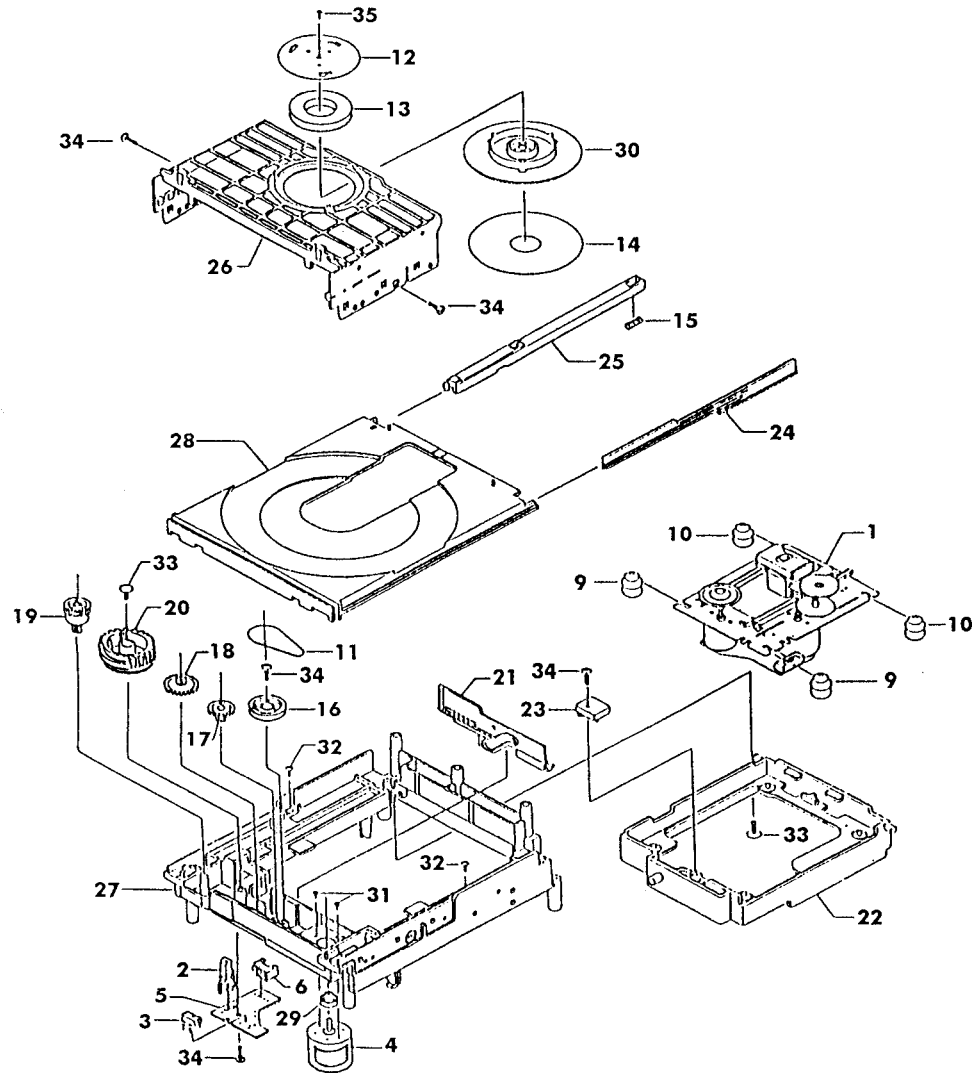

## EXPLODED VIEW PARTS LIST OF MECHANISM CD93F8

Item	Part No	Description	Qty
1	4102-5002-0	CD94V5 MECHANISM	1
2	4102-5003-0	SWITCH LEAF	1
3	4102-5004-0	SWITCH PUSH 2-1	1
4	4102-5005-0	LOADING MOTOR	1
5	4102-5006-0	CON/SW PCB	1
6	4102-5007-0	CON JST 5P RT	1
9	4102-5008-0	Hardness 60° CUSHION RUBBER	2
10	4102-5009-0	Hardness 50° CUSHION RUBBER	2
11	4102-5010-0	BELT SQUARE	1
12	4102-5011-0	PLATE MAGNET	1
13	4102-5012-0	MAGNET DISK	1
14	4102-5013-0	SHEET	1
15	4102-5014-0	SPRING RAIL	1
16	4102-5015-0	PULLEY GEAR	1
17	4102-5016-0	GEAR IDLER A	1
18	4102-5017-0	GEAR IDLER B	1
19	4102-5018-0	GEAR TRAY	1
20	4102-5019-0	GEAR MEDIATION	1
21	4102-5020-0	SLIDER	1
22	4102-5021-0	CDM MOUNTING BASE	1
23	4102-5022-0	FIXITY	1
24	4102-5023-0	RAIL RIGHT	1
25	4102-5024-0	RAIL LEFT	1
26	4102-5025-0	SUPPORT MAGNET	1
27	4102-5026-0	BASE FRAME	1
28	4102-5027-0	CD TRAY	1
29	4102-5028-0	PULLEY MOTOR	1
30	4102-5029-0	HOLDER MAGNET	1
31	4102-5030-0	SCREW PAN+SW 1.7x3.5	2
32	4102-5031-0	SCREW S-TPG PAN+FLG 2x6	2
33	4102-5032-0	SCREW S-TPG BRZ+FLG 3x8	2
34	4102-5033-0	SCREW S-TPG BIN 2.6x7.8	5
35	4102-5034-0	SCREW SPECIAL 1.7x4.0	1



# ELECTRICAL PARTS LIST

Reference No.	Part No.	Description
<b>DISPLAY ASSEMBLY PCB BOARD</b>	PCB-N0790C-DISP	DISPLAY ASSEMBLY
<b>AC LAMPS</b> M503-M505	2450-0966-0	AC LAMP 10V 60mA D5MM
<b>KEYBOARD ASSEMBLY PC BOARD</b>	PCB-N0790C-KEY	KEYBOARD ASSEMBLY
<b>SWITCHES</b> M101-M104,M106 M108-M112	5200-3291-0-01 5200-3291-0-01	TACT SW ALPS SKHHAR TACT SW ALPS SKHHAR
<b>IR SENSOR</b> M113	4812-043T-3	IR SENSOR MODULE
<b>LIVE ASSEMBLY PC BOARD</b> *AH *B,*B1,*C	PCB-N0790C-LIVE PCB-N0791C-LIVE	LIVE ASSEMBLY LIVE ASSEMBLY
<b>CAPACITOR</b> C800 $\Delta$	8910-0049-0	CAP400V 4700P DE7150F472MVA1KC
<b>FUSE</b> M801*AH $\Delta$	5120-0031-0	FUSE 250V 500mA TIME LAG HIGH SURGE UL/CSA
M801*B,*B1,*C $\Delta$	5120-0057-0	FUSE 250V 125mA TIME LAG SEMKO/VDE
<b>TRANSFORMER ASSEMBLY PC BOARD</b>	PCB-N0790C-PWR	TRANSFORMER ASSEMBLY
<b>TRANSFORMER</b> T1 $\Delta$	1806-2194-0	TRANSFORMER EI-57
<b>MAIN ASSEMBLY PC BOARD</b>	PCB-N0790C-MAIN	MAIN ASSEMBLY
<b>CAPACITORS</b> C101 C104 C106 C107 C109 C113	153F-104J-5-PT 153F-333J-5-MS 153F-473K-5-NO 157F-104M-5-IU 153F-154K-5-KM 153F-104J-5-PT	CM 50V 0.1 $\mu$ F 5% CM 50V 0.033 $\mu$ F 5% CM 50V 0.047 $\mu$ F 10% CE 50V 0.1 $\mu$ F 20% CM 50V 0.15 $\mu$ F 10% CM 50V 0.1 $\mu$ F 5%

Ref. No.	Part No.	Description
C114	153F-153K-5-KP	CM 50V 0.015 $\mu$ F 10%
C115	153F-183J-5-KP	CM 50V 0.018 $\mu$ F 5%
C118	157F-224M-5-IU	CE 50V 0.22 $\mu$ F 20%
C119	157E-475M-5-GM	CE 25V 4.7 $\mu$ F 20%
C120	157E-226K-5-IU	CE 25V 22 $\mu$ F 10%
C122	15CH-010C-5-GG	CC 50V 1pF +/-0.25pF NPO
C123	153F-222J-5-IM	CM 50V 2200pF 5%
C124	15CH-120J-5-GG	CC 50V 12pF 5% NPO
C125	153F-333J-5-MS	CM 50V 0.033 $\mu$ F 5%
C126	157E-106M-5-IU	CE 25V 10 $\mu$ F 20%
C128-C129	157B-107M-5-KM	CE 6.3V 100 $\mu$ F 20%
C129	157B-107M-5-KM	CE 6.3V 100 $\mu$ F 20%
C131	153F-473J-5-NR	CM 50V 0.047 $\mu$ F 5%
C132	157F-334K-5-IU	CE 50V 0.33 $\mu$ F 10%
C134	157C-476M-5-IU	CE 10V 47 $\mu$ F 20%
C135	157B-227M-5-KW	CE 6.3V 220 $\mu$ F 20%
C138	157E-106M-5-IU	CE 25V 10 $\mu$ F 20%
C139	157B-107M-5-KM	CE 6.3V 100 $\mu$ F 20%
C141	157F-225M-5-GM	CE 50V 2.2 $\mu$ F 20%
C157	157C-477M-5-OW	CE 10V 470 $\mu$ F 20%
C202	157C-108M-5-S5	CE 10V 1000 $\mu$ F 20%
C204	157F-105M-5-GM	CE 50V 1 $\mu$ F 20%
C301	153F-104J-5-PT	CM 50V 0.1 $\mu$ F 5%
C304,C308	157B-107M-5-KM	CE 6.3V 100 $\mu$ F 20%
C320-C325	157B-106M-5-EI	CE 6.3V 10 $\mu$ F 20%
C328-C329	15CH-200J-5-GG	CC 50V 20pF 5% NPO
C332,C334	157B-106M-5-EI	CE 6.3V 10 $\mu$ F 20%
C356-C357	153F-272J-5-JM	CM 50V 2700pF 5%
C362-C363	153F-472J-5-KM	CM 50V 4700pF 5%
C366-C367	158F-681J-5-KW	CP 50V 680pF 5%
C368-C369	157E-226K-5-IU	CE 25V 22 $\mu$ F 10%
C371-C374	157D-107M-5-KW	CE 16V 100 $\mu$ F 20%
C375-C376	157E-226M-5-IU	CE 25V 22 $\mu$ F 20%
C377-C379,C382	153F-224K-5-MIB	CM 50V 0.22 $\mu$ F 10%
C402	157B-107M-5-KM	CE 6.3V 100 $\mu$ F 20%
C407	157C-108M-5-S5	CE 10V 1000 $\mu$ F 20%
C410	157B-106M-5-EI	CE 6.3V 10 $\mu$ F 20%
C506-C507	157E-228M-5-X9	CE 25V 2200 $\mu$ F 20%
C508	157C-108M-5-S5	CE 10V 1000 $\mu$ F 20%
C511	157C-227M-5-KW	CE 10V 220 $\mu$ F 20%
C512-C513	157D-108M-5-S5	CE 16V 1000 $\mu$ F 20%
C518-C519	157E-107M-5-KW	CE 25V 100 $\mu$ F 20%
C522-C523	157D-107M-5-IU	CE 16V 100 $\mu$ F 20%
C525	157D-477M-5-OY	CE 25V 470 $\mu$ F 20%
C527	157C-108M-5-S5	CE 10V 1000 $\mu$ F 20%
C529	157D-338M-5-W@	CE 16V 3300 $\mu$ F 20%
C530-C531	157E-107M-5-KW	CE 25V 100 $\mu$ F 20%
C533	157C-108M-5-S5	CE 10V 1000 $\mu$ F 20%
C702	157C-476M-5-IU	CE 10V 47 $\mu$ F 20%
C710	157B-107M-5-KM	CE 6.3V 100 $\mu$ F 20%
<b>DIODES</b> D401-D403,D407-D408 D501-504 D505 D512-D513 D514-D517 D701	4804-1480-2 4804-0010-2 4837-3C20-2 4804-1480-2 4804-0010-2 4837-5V11-2	DIODE 1N4148 AT DIODE 1N4001 AT DZ 1/2W 4.1-4.3V AT DIODE 1N4148 AT DIODE 1N4001 AT DZ 1/2W 5.1V ROHM AT