

SCHEMATIC DIAGRAM

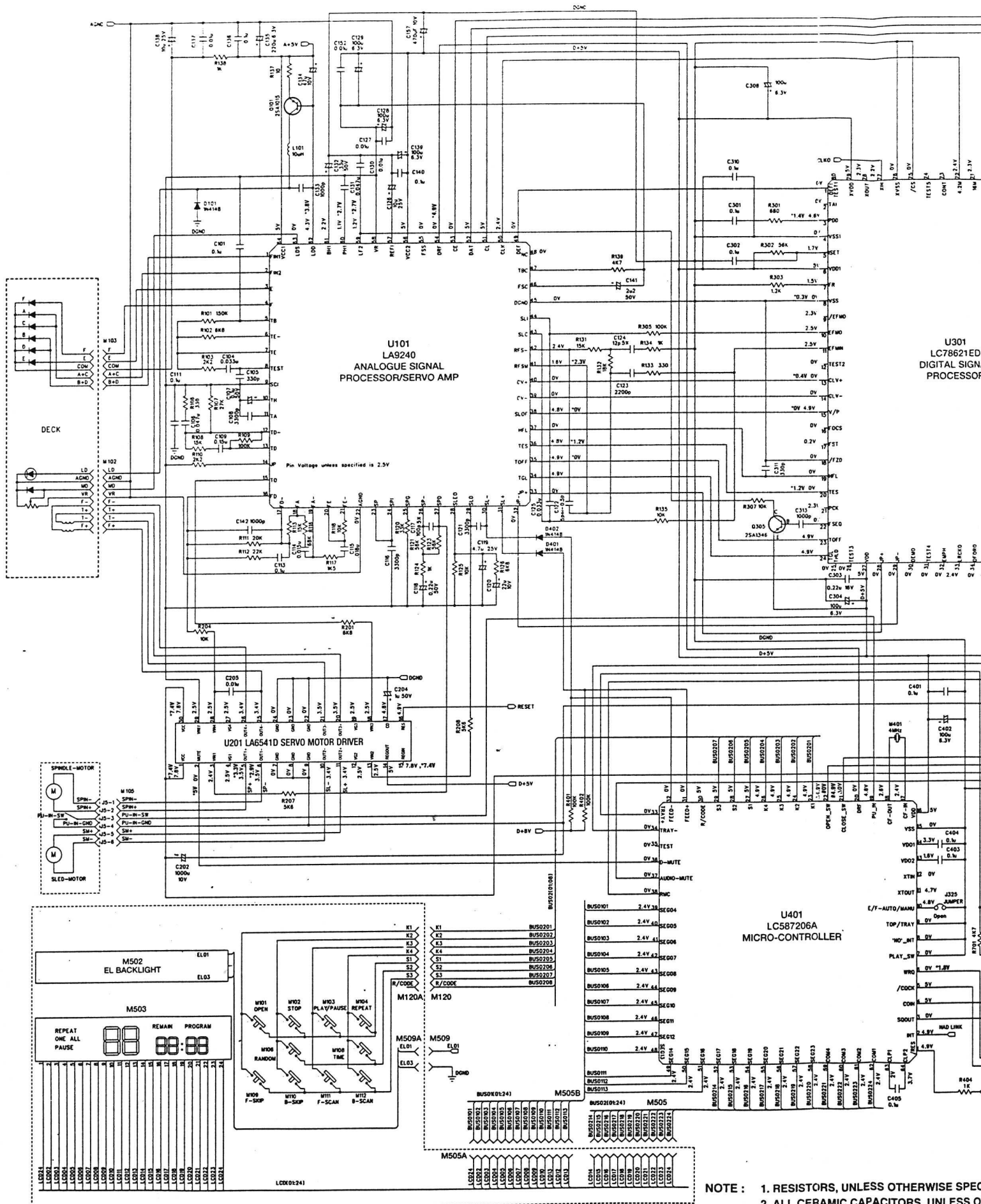

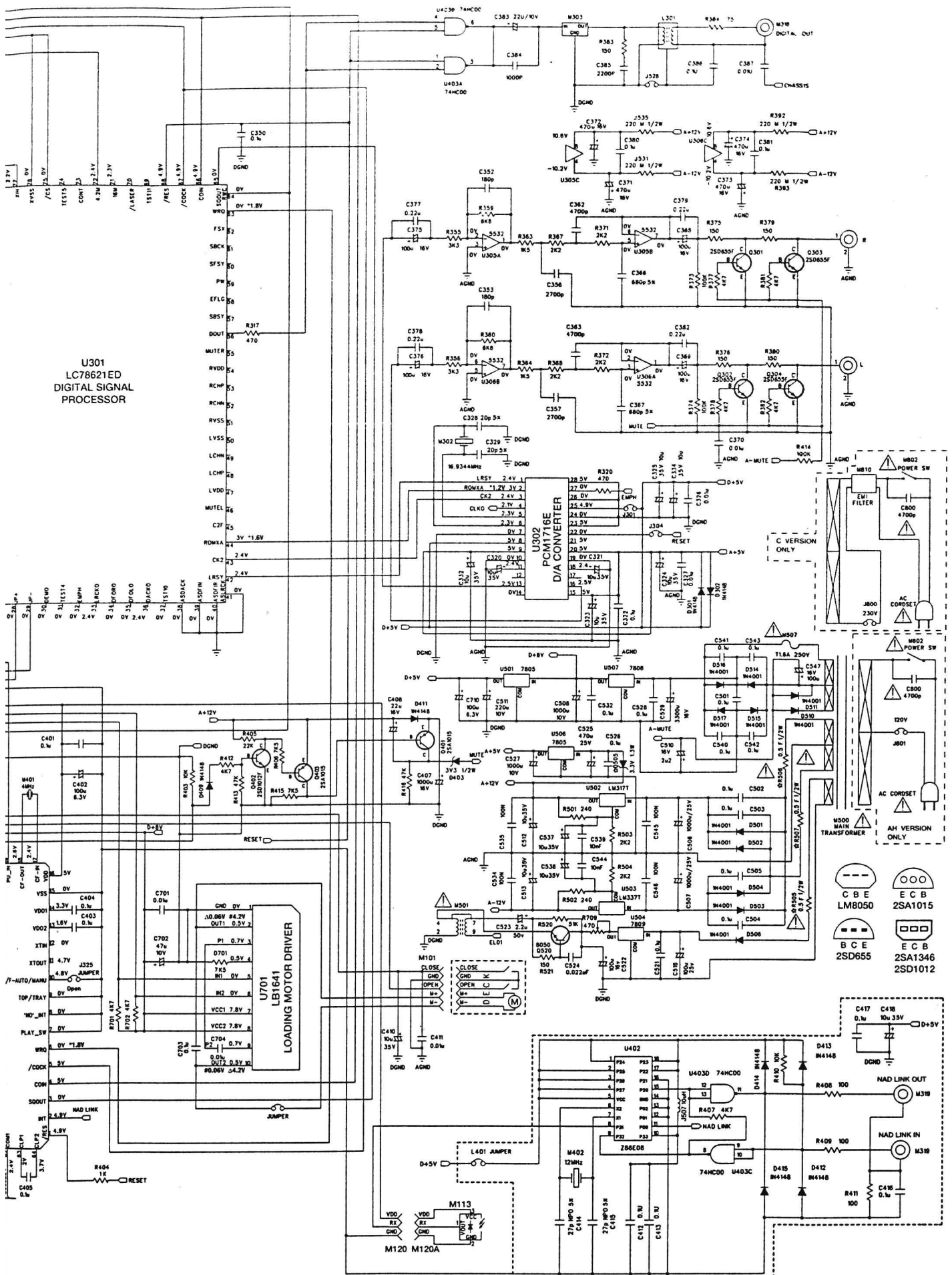

RESISTORS UNLESS OTHERWISE SPECIFIED, ARE 1/4 WATT.
 CAPACITORS UNLESS OTHERWISE SPECIFIED, ARE 50V, 10%.
 MARKED "▲" ARE SAFETY CRITICAL PARTS.
 MARKED "☆" ARE RAISED 10MM FROM PCB.
 "STOP" ON THE IC'S PIN WHICH DOES NOT HAS MARKING IS IN STOP MODE.
 "1" IS PLAY MODE, "*" IS TRAY OPEN MODE AND "Δ" IS

RESISTORS : M - METAL FILM
 F - FUSIBLE
 CARBON FILM UNLESS OTHERWISE SPECIFIED.