

SERVICE MANUAL

NAD

602

**CASSETTE
DECK**

602

**CASSETTE
DECK**

CONTENTS

DESCRIPTION	PAGE
SPECIFICATIONS.....	3
REAR PANEL /FRONT PANEL VIEW.....	4
BLOCK DIAGRAM.....	5
WIRING DIAGRAM.....	6
DISASSEMBLY INSTRUCTIONS.....	7
ALIGNMENT METHOD.....	8-9
TROUBLE SHOOTING GUIDE.....	10
SCHEMATIC DIAGRAM (MAIN PCB.).....	11-12
PCB LAYOUT (MAIN PCB.).....	13-14
SCHEMATIC AND PCB LAYOUT (DISPLAY).....	15
EXPLODED VIEW.....	16
EXPLODED VIEW PARTS LIST.....	17
MECHANISM EXPLODED VIEW PARTS LIST.....	18
MECHANISM EXPLODED VIEW.....	19-20
PARTS LIST.....	21-23
PACKING DIAGRAM.....	24
NOTES.....	25

SPECIFICATIONS

Speed Accuracy	+/-1%
Wow and Flutter	< 0.06% JIS wtd. RMS < 0.1% DIN wtd. peak
Frequency Response (Dolby NR off, Record/Playback)	35Hz-16kHz +/-3dB
MPX Filter Response	Flat within 1dB to 15kHz
Harmonic Distortion	Varies with recording level; typically < 0.3% at -10dB
THD at 0dB	(Normal tape)	< 1%
	(CrO2, Metal)	< 1.5%
Signal-to-Noise Ratio	50dB (Dolby off)
(ref. 3% THD at 333Hz (Biased Tape) CCIR/ARM weighting)		60dB (Dolby B) 70dB (Dolby C)
Channel Separation	40dB at 1kHz 35dB broadband
Erasure	< 70dB at 1kHz
Input Sensitivity/Impedance	40mV/10K ohm
Maximum Input Level25V
Output Level at 0dB	500mV
Output Impedance	1k ohm

PHYSICAL SPECIFICATIONS

Dimensions (W x H x D)	420 x 126 x 250mm
Net Weight	4.4kg
Shipping Weight	5.3kg
Power Consumption at 120, 220 or 240VAC 50/60Hz	22W

REAR PANEL /FRONT PANEL VIEW

REAR PANEL

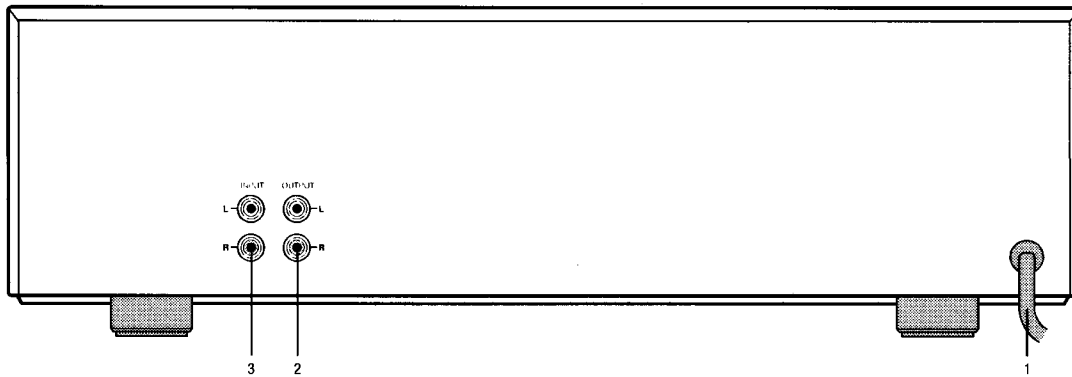

1. AC LINE CORD
2. OUTPUT
3. INPUT

FRONT PANEL

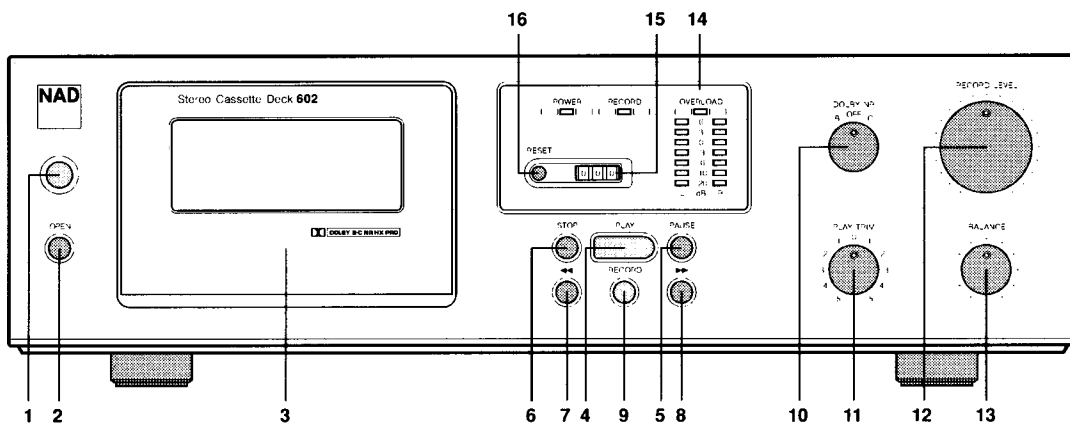

- | | |
|-------------------------|------------------|
| 1. POWER | 9. RECORD |
| 2. OPEN | 10. DOLBY |
| 3. CASSETTE COMPARTMENT | 11. PLAY TRIM |
| 4. PLAY | 12. RECORD LEVEL |
| 5. PAUSE | 13. BALANCE |
| 6. STOP | 14. DISPLAY |
| 7. REWIND<< | 15. TAPE COUNTER |
| 8. FAST FORWARD>> | 16. RESET |

BLOCK DIAGRAM

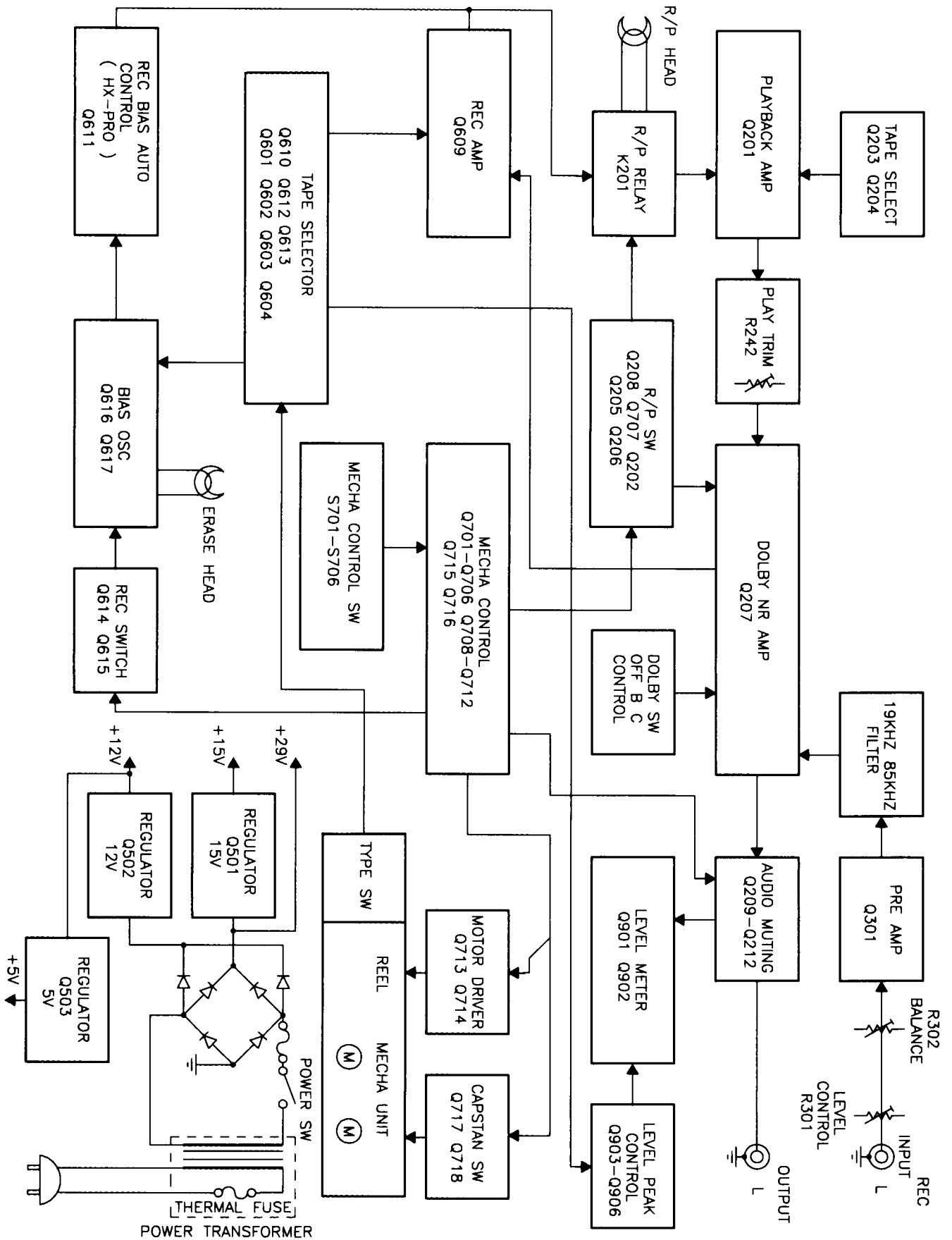

WIRING DIAGRAM

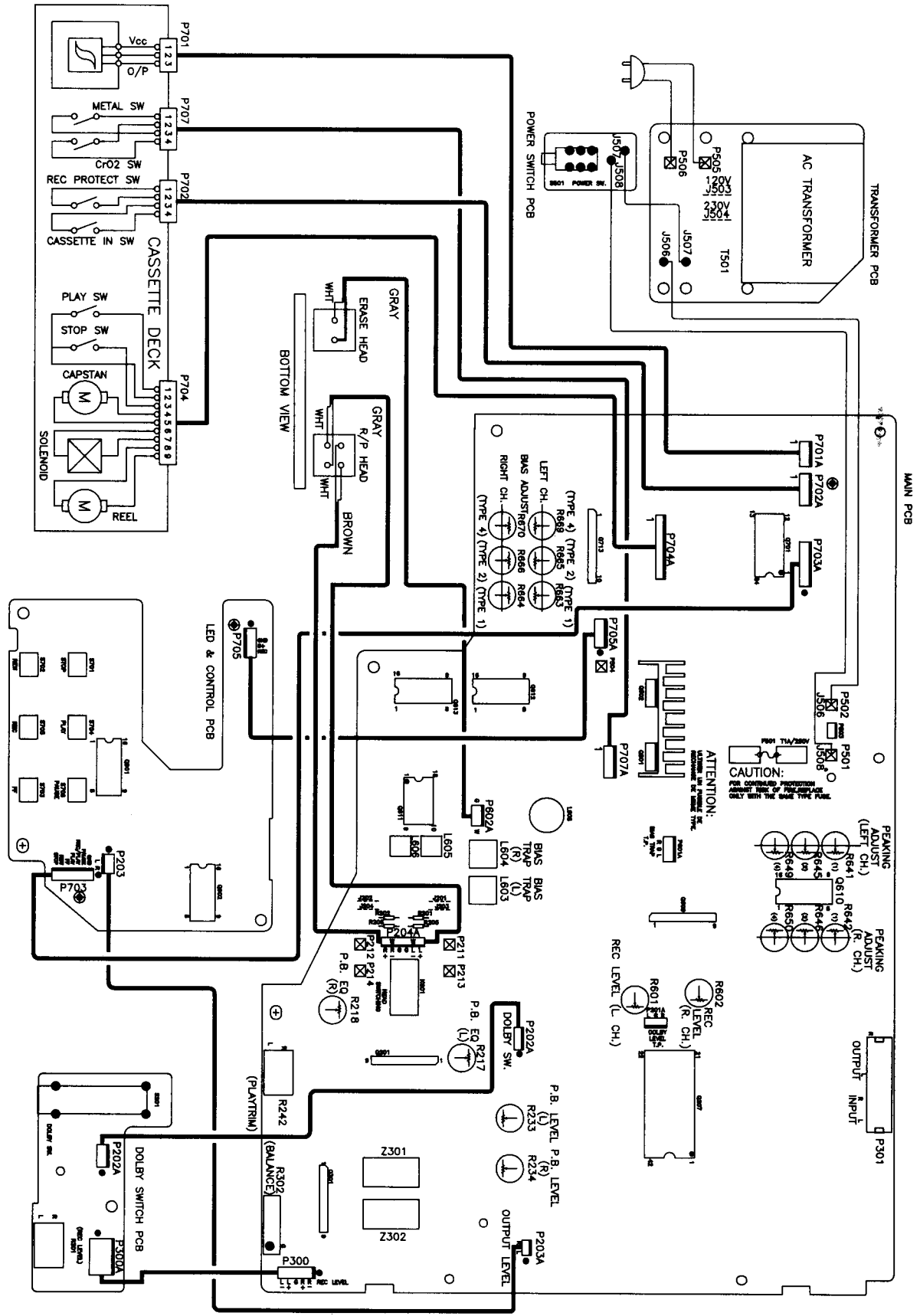

DISASSEMBLY INSTRUCTIONS

TOP COVER REMOVAL

1. Remove parts in order of disassembly as numbered.
 - a. ①-⑥ Machine screw M 4.0x8.0 (See Fig. 1.)
 - b. ⑦ Tapping screw M 3.0x8.0 (See Fig. 1.)

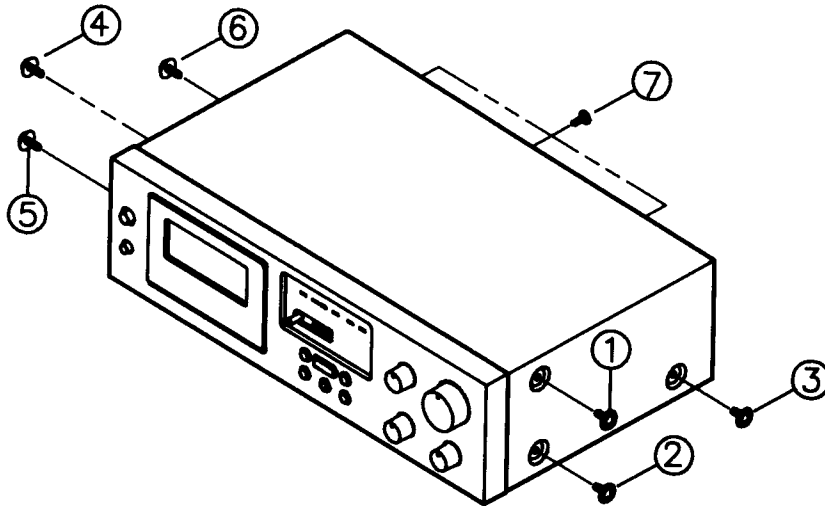

Fig. 1.

2. Pull both sides of TOP COVER outward and turn about 35° (shown as arrow ⑧) then remove as arrow ⑨ shows. (See Fig. 2.)

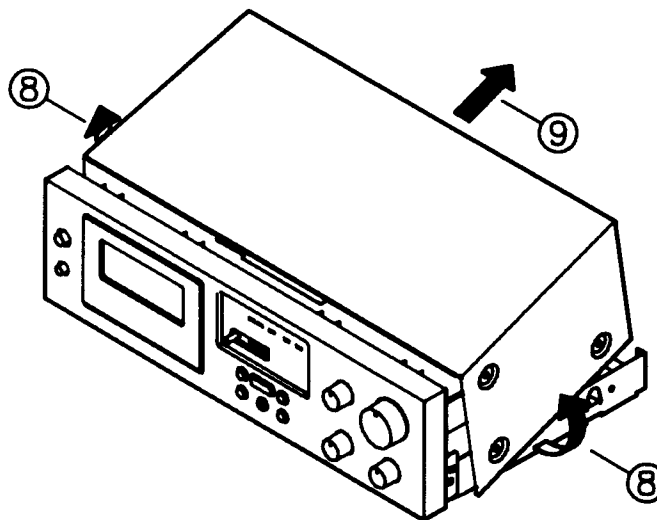

Fig. 2.

ALIGNMENT METHOD

IMPORTANT

The tape path (heads, tape guides, capstan, pinch roller) should be cleaned and degaussed before alignment.

This tape recorder is designed to work well with a variety of tapes, however, maximum performance will be obtained with recommended tapes or similar tape formulations.

Recommended tapes	For North America	For Europe-DIN
Type I	Maxell UDS-I	Maxell UD-I, BASF TP18, R723DG
Type II	Maxell XL-II	Maxell XL-II, Teac MTT-5561
Type IV	Maxell MX	Maxell MX, TDK AC712

Before adjusting, switch DOLBY NR off, and set PLAY TRIM to center position.

DOLBY NR level 200nWb/m = 245mV RMS on testpoints P201A (PLAYBACK and RECORDING) on Main PCB; approximately 530mV at line outputs.

1. TAPE SPEED

Connect one output to Wow and Flutter Meter or Frequency Counter, Play speed test tape TEAC MTT-111=3kHz or TEAC MTT-211=3.15kHz and adjust the semi-variable resistor, for correct reading on Wow and Flutter Meter or Frequency Counter. (See Fig. A) **Tolerance:** +/-1%

2. AZIMUTH

Connect VTVM's and / or Oscilloscope to outputs. Start playing Azimuth tape TEAC MTT-113 or MTT-114. Rotate azimuth screw for maximum output and / or maximum and in-phase on Oscilloscope. Reseal adjustment screw with nail polish or similar (do not use glue). (See Fig. B)

3. PLAYBACK EQ

THIS ADJUSTMENT IS NOT NEEDED UNLESS THE HEAD HAS BEEN REPLACED OR REPAIR HAS BEEN DONE IN HEADAMP CIRCUIT.

Play level / azimuth tape TEAC MTT-256 and adjust R217 (L) and R218 (R) for identical output at 315 / 6300 Hz (MTT-255) or 250 / 6300 Hz (MTT-256).

Tolerance: +/-0.5dB

4. PLAYBACK HIGH FREQUENCY EQ

THIS ADJUSTMENT SHOULD BE DONE ONLY WHEN HEAD HAS BEEN REPLACED.

Before adjusting, cut the links J201 to J208. Play the frequency response tape TEAC MTT-256 or MTT-256U and check the playback level at 14kHz. Adjust to the 400Hz level by connecting the links J201 to J208, as follows:

If it is higher link J205(L) & J206(R).

Links J207(L) & J208(R) will reduce it further.

If level is lower then link J201(L) & J202(R) and / or J203(L) & J204(R) which will increase the level.

Tolerance: +1.5/-0.5dB

5. PLAYBACK LEVEL

Connect VTVM's to testpoints P201A on Main PCB.

Play Dolby NR level tape TEAC MTT-150 and adjust R233 (L) and R234(R) for 245mV RMS.

Tolerance: +/-2.5mV RMS.

Output should be approximately 530mV RMS.

6. BIAS TRAP

Insert a blank type IV tape and start recording. Turn record level all the way down. Connect VTVM's and/or oscilloscope probes to testpoints P601A and adjust L603 (L) and L604 (R) for minimum.

Tolerance: Less than 300mV RMS.

7. RECORD LEVEL

Connect VTVM's to testpoints P201A on Main PCB. Insert a type I tape. Connect audio oscillator to line inputs, turn record levels to maximum (clockwise). Adjust audio oscillator frequency to 400Hz and output so that VTVM's read 30-40mV. (Use a convenient reference point on the VTVM's)

Reset tape counter to 0 and release pause to start recording. Record for approximately 5 seconds, rewind to 0 on tape counter and play back while observing the VTVM's. The VTVM's should indicate the same level as when the tape was recorded. Adjust R601(L) and R602(R) if necessary and repeat the record / play procedure until the readings are the same.

Tolerance: +/-0.5dB from record level. Less than 0.5dB difference between channels.

8. BIAS ADJUST TYPE I TAPE (NORMAL)

Leave the connections of the VTVM's as under 7.

Set audio generator to 400Hz. Set level to -20dB.

Reset tape counter to 0 and start recording. After 5 seconds change audio generator frequency to 6.3kHz (do not stop the machine or change levels) and continue recording for another 5 seconds Stop and rewind to 0 on tape counter. Play back while observing VTVM's. There should be no level difference between the 400Hz and the 6.3kHz tone when played back.

If 6.3kHz is different in level to 400Hz, adjust R663(L) and R664 (R) and repeat the record / play procedure until both frequencies play back at same level.

Tolerance: +/-0.5dB

WARNING: Greater tolerance will grossly affect the Dolby NR tracking and especially the Dolby C tracking.

Record level (step 7) should be checked and if necessary adjusted.

9. PEAKING CIRCUIT TYPE I TAPE (NORMAL)

Leave the connections of the VTVM's as under 7. Adjust audio generator to 14kHz while maintaining the same output level. Record and play back the 14kHz tone and adjust R641 (L) and R642 (R) to the same level as the 400Hz signal. **Tolerance: +/-1dB**

WARNING: If the R/P head is worn, the tape may not have adequate contact with the head, resulting in severe drop outs. A worn head will make this adjustment very difficult or impossible. DO NOT try to adjust the worn R/P head. Leave R641 (L) and R642 (R) in the factory preset condition, or if they have already been adjusted, re-adjust them to their approximate midposition.

10. FREQUENCY RESPONSE TYPE II TAPE (CrO2)

Insert a type II tape. Adjust audio generator to 400Hz and 6.3kHz and repeat procedure described in step 8 using R665 (L) and R666 (R) to adjust both channels simultaneously. After 400Hz and 6.3kHz are adjusted properly, set audio generator to 14kHz and repeat same procedure as described in step 9 while adjusting R645 (L) and R646 (R) to obtain correct reading.

11. FREQUENCY RESPONSE TYPE IV TAPE (METAL)

Insert a type IV tape. Repeat procedure as in step 8 while adjusting R669 (L) and R670 (R) for correct 6.3kHz level in both channels. Set audio generator to 14 kHz and repeat procedure as in step 9 while adjusting R649 (L) and R650 (R) for correct 14kHz record level.

ALIGNMENT COMPONENTS LAYOUT

Fig. A FOR ADJUSTING TAPE SPEED

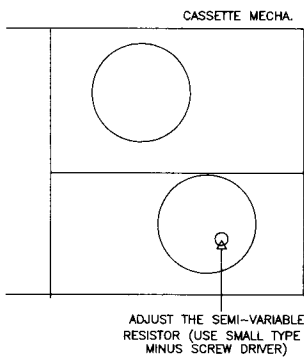

Fig. B FOR ADJUSTING AZIMUTH

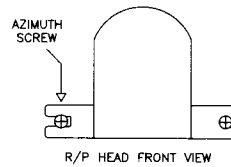
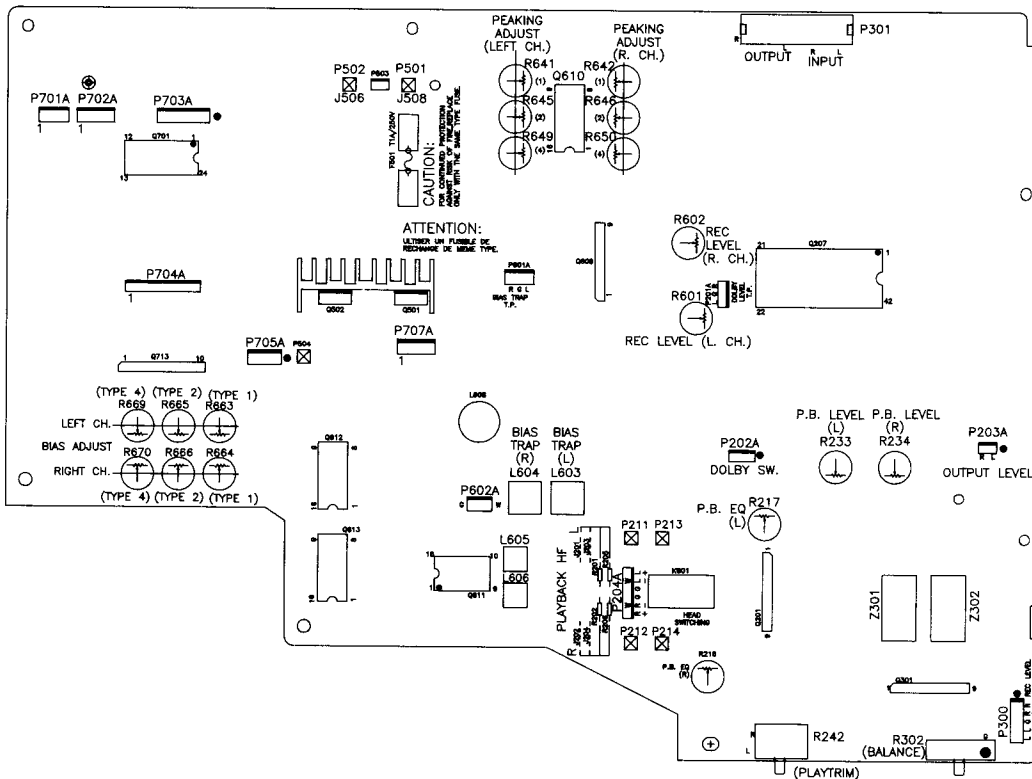
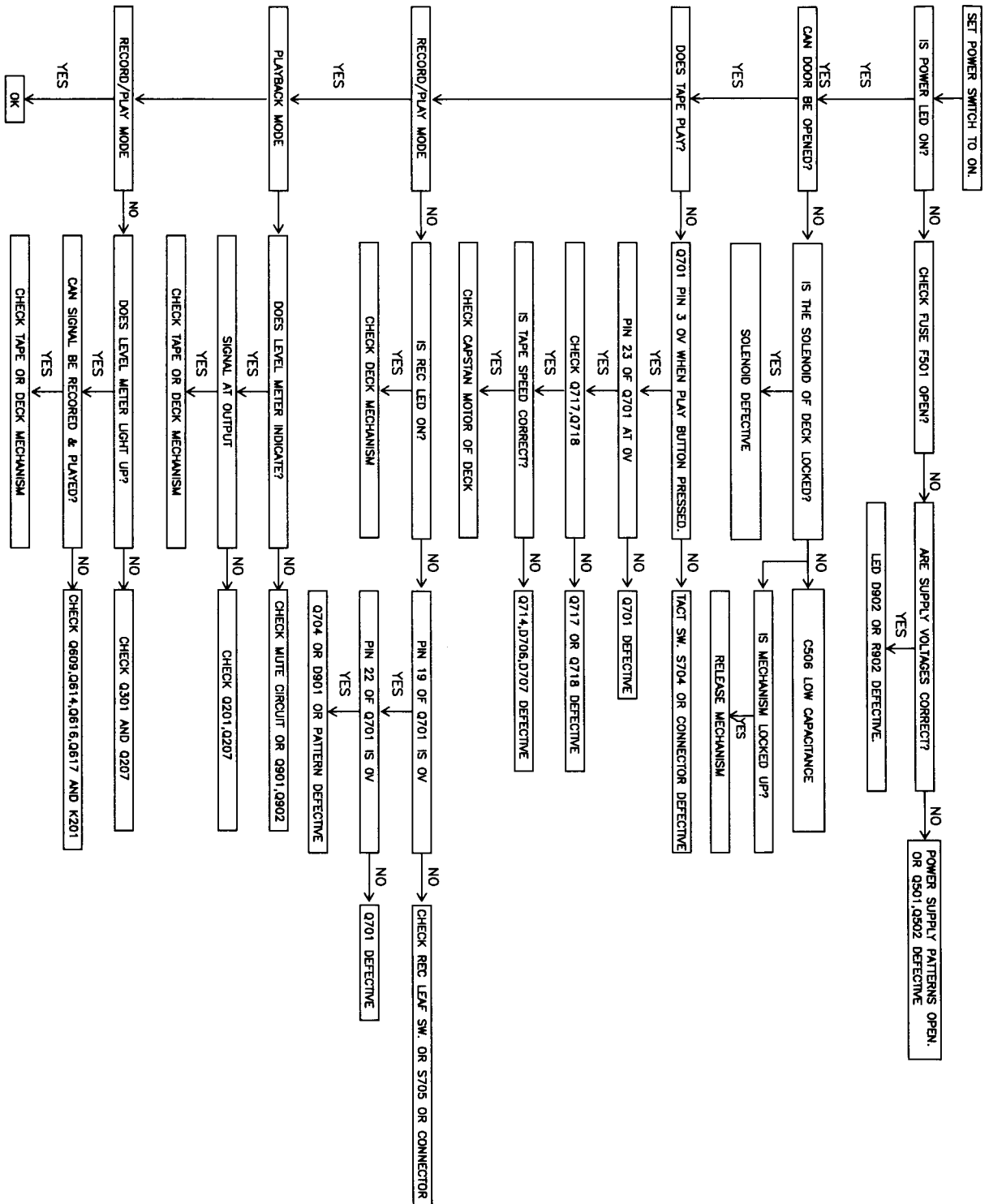

Fig. C FOR MAIN PCB



TROUBLE SHOOTING GUIDE



PCB LAYOUT (MAIN PCB.)

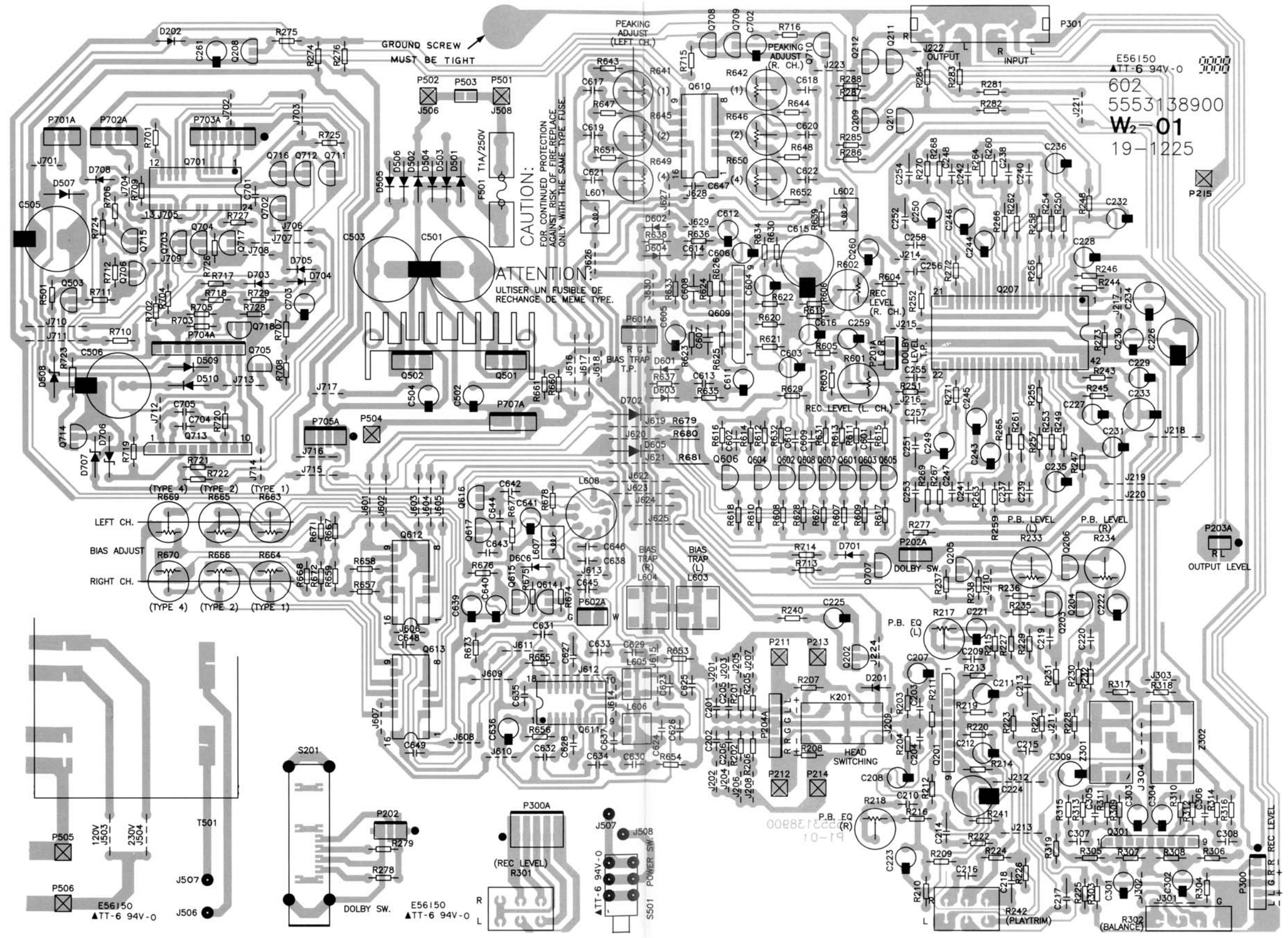

SCHEMATIC AND PCB LAYOUT (DISPLAY)

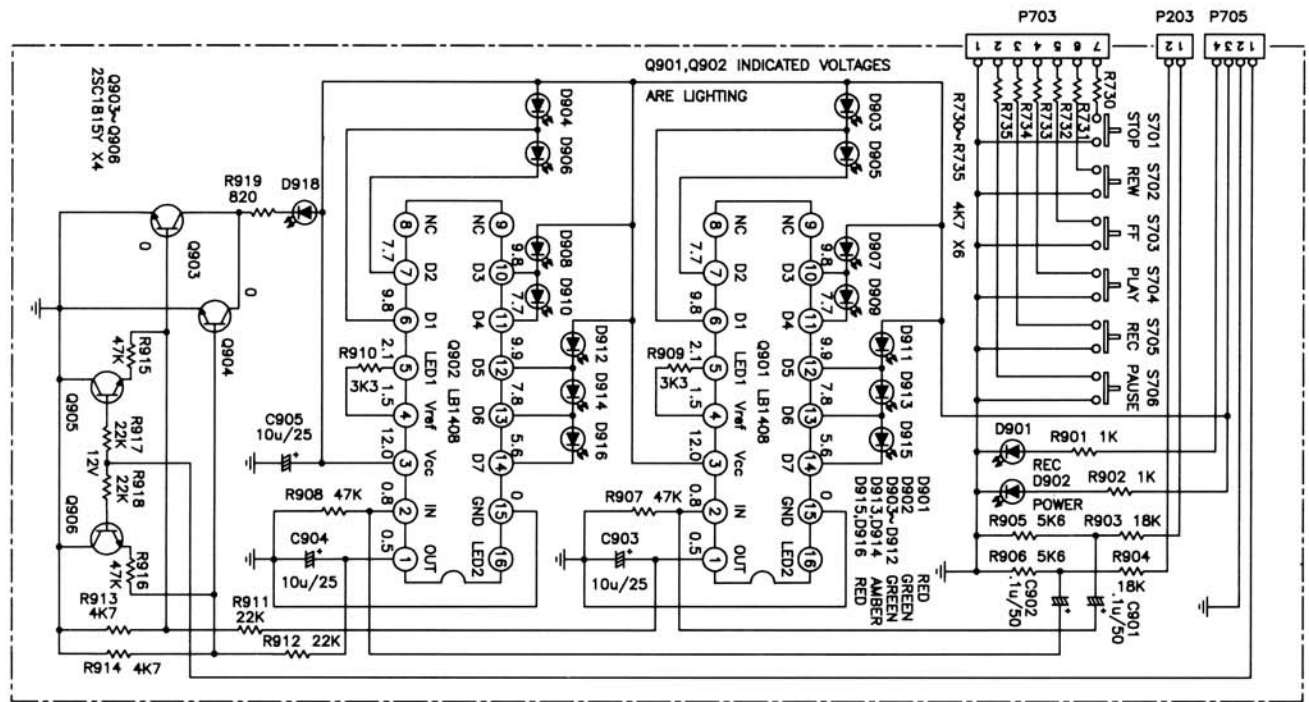

(C) NAD Electronics Ltd. 1993

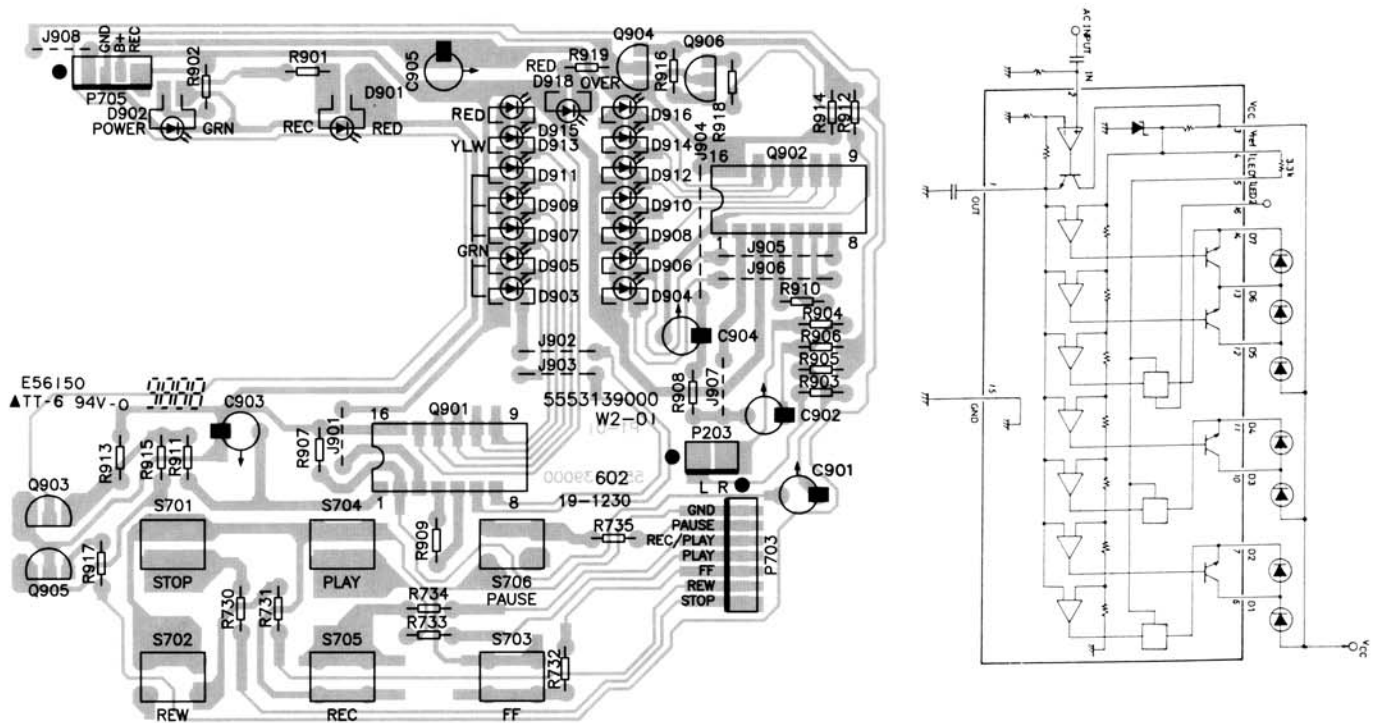

EXPLODED VIEW

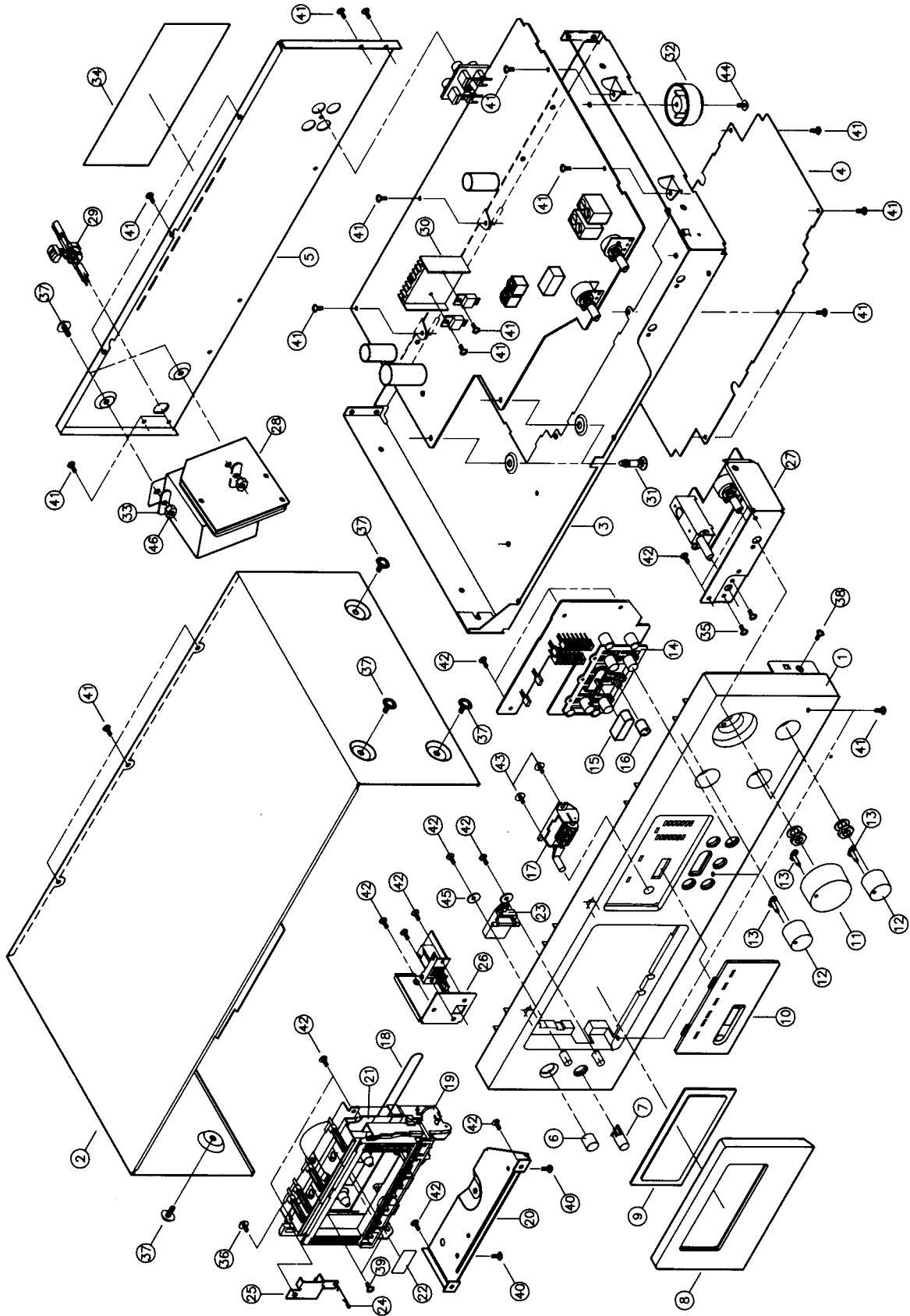

EXPLODED VIEW PARTS LIST

ITEM	PART NO.	DESCRIPTION	Q'TY
1	5541309400	FRONT PANEL	1
2	5541003900	TOP COVER	1
3	5547140600	CHASSIS	1
4	5547140700	CHASSIS A	1
5	5547140800	BACK PLATE	1
6	5541548700	POWER BUTTON	1
7	5541548900	OPEN BUTTON	1
8	5542251700	CASSETTE COVER	1
9	5542261000	DECK WINDOW	1
10	5542236000	FASCIA WINDOW	1
11	5541547100	REC. LEVEL KNOB	1
12	5541547000	CONTROL KNOB	3
13	5547612600	POINTER	4
14	5541549000	DECK CONTROL BUTTON	1
15	5541549100	PLAY BUTTON	1
16	5541548800	REC. BUTTON	1
17	5549301600	COUNTER (T3SG100-050B1-839)	1
18	5531101060	COUNTER BELT (ϕ 75 x 1.0t)	1
19	5557306100	CASSETTE MECHANISM (C-90F02D)	1
20	5547046200	MECH. BRACKET	1
21	5547046300	DUST COVER	1
22	5535426640	REFLECTOR	1
23	5542235900	EJECT LEVER	1
24	5546325700	EJECT SPRING	1
25	5547046600	EJECT BRACKET	1
26	5547046500	BRACKET (L)	1
27	5547064600	BRACKET (R)	1
28	5547535000	POWER SHIELD	1
29	5547501200	POWER CORD BUSHING	1
30	5545310600	HEAT SINK (A)	1
31	5547530491	PCB HOLDER	2
32	5542234500	FOOT (EVA)	4
33	5542805500	TRANSFORMER BRACKET	2
34*AH	5535450606	BACK LABEL (120V/60Hz) AH	1
34*B1,C	5535460607	BACK LABEL (220-240V/50Hz) B1, C	1
35	7001170616	SCREW (MS M3x6) BLK	2
36	7000311016	SCREW (MS M3x8+WASHER) BLK	1
37	7190550012	SCREW (MS M4x8+WASHER) BLK	8
38	7034161156	SCREW (TS FLT M3x8) BLK	2
39	7131120256	SCREW (TS M2.5x4 S-TITE) BLK	2
40	7131160252	SCREW (TS M3x4 S-TITE) ZN	2
41	7033161156	SCREW (TS M3x8) BLK	27
42	7033161452	SCREW (TS M3x10) ZN	17
43	7036121152	SCREW (TS M2.5x8+WASHER) ZN	2
44	7000305012	SCREW (TS M3x8+WASHER) ZN	4
45	7190555001	WASHER (ϕ 3.3x ϕ 10x1.0t) BLK	2
46	7076260012	NUT M4 ZN	2

MECHANISM EXPLODED VIEW PARTS LIST

PART NO.	DESCRIPTION	Q'TY
A00960	SOFT DAMP ASSY 3B	1
A01950	RF ASSY 90A	1
E02650	HALL IC (DN-6838)	1
E02950	PCB. IC-20	1
E02960	MAGNET 15 x 7.2 x 3 - 12	1
F00510	FLYWHEEL 90B	1
H01080	E HEAD LE15-C1	1
K06460	HEAD PANEL ASSY 90A	1
K06470	CASE HOLDER ASSY 90A-L	1
M00640	MOTOR RF510T-081200N	1
M00690	MOTOR EG530AD-2B	1
P01030	SOLENOID ASSY	1
Q06210	SPRING, CAPSTAN SUPPORT 8RA	1
Q06370	SPRING, HEAD 9FA	1
Q07720	SPRING, TRIGGER LEVER 90A	1
Q07730	SPRING, BRAKE ARM 90A	1
Q07740	SPRING, HEAD PANEL 90A	1
Q07750	SPRING, GEAR ASSIST ARM 90A	1
Q07760	SPRING, PINCH ROLLER	1
Q07770	SPRING, PINCH ROLLER ASSIST	1
Q07810	SPRING, SAFETY ARM 90A	1
Q07840	SPRING, BACK TENSION	2
Q07870	SPRING, CASSETTE CASE 90B	1
Q07880	SPRING, CASE LOCK LEVER 90B	1
S01280	SWITCH LSA1132FAU	4
S01320	LEAF SWITCH LSA-1119R	2
T01340	PINCH ROLLER ASSY 90A	1
U00340	RUBBER CUSHION	3
U03960	CAPSTAN SUPPORT 9B	1
U04980	REEL PLATE 9FA	2
U04990	HUB DRIVER 9FA	2
U05070	FLAT BELT 58.5 x 3.5 x 0.4	1
U05080	MOTOR PULLEY 2 x 9.2	1
U06440	GEAR BASE 90A	1
U06450	TRIGGER LEVER 90A	1
U06460	GEAR ASSIST ARM 90A	1
U06470	BRAKE ARM 90A	1
U06480	CASSETTE GUIDE 90A	2
U06510	HEAD BASE 90A	1
U06582	CASE LOCK LEVER 90A	1
U06600	CASSETTE CASE 90A	1
U06670	RF PULLEY GEAR 90A	1
U07020	DRIVE GEAR 90B-1	1
V02910	COLLER	3
W02380	COLLER, SAFETY ARM 90A	1
Y08320	SHIELD PLATE 30 x 17	1
Y09010	SPRING PLATE 90A	1
Y09080	SAFETY ARM 90A	1
Y09100	CASE HOLDER 90A-R	1
Y09120	MOTOR BRACKET	1
Y09330	SWITCH COVER 90B	1

PART NO.	DESCRIPTION	Q'TY
7442CS	RP HEAD RP7442CS-09	1
080920	BIND SCREW 2 x 11	2
170960	PAN HEAD TAPPING SCREW 2 x 5	1
171450	TAPPING SCREW 2.6 x 4	4
171470	TAPPING SCREW 2.6 x 6	1
190850	PAN HEAD SCREW 2 x 4 SW	1
190920	PAN HEAD SCREW 2 x 11 SW	1
201480	SCREW 2.6 x 7 W/WASHER	3
230370	PAN HEAD SCREW 2.6 x 2.5	2
230420	BIND SCREW +/- 2 x 10	1
230620	SHOULDEC SCREW 2.6 x 9	2
230630	TAPPING SCREW 2.6 x 23.5	1
230700	BIND TAPPING SCREW 2 x 4	4
230720	SHOULDEC SCREW 2.6 x 5	1
230740	TRUSS TAPPING SCREW 2.6 x 6	1
301200	FLAT WASHER 2.2 x 6 x 0.4	1
301260	FLAT WASHER 2.8 x 7.5 x 0.5	1
322020	PSW 2.1 x 4 x 0.25	1
322050	PSW 1.6 x 4 x 0.5	3
400010	SPACER M2.6 x 20 ZMC	1
430150	PSW 2.1 x 4 x 0.4 CUT	1
430160	PSW 1.6 x 3.2 x 0.4 CUT	2
430170	NYLON WASHER 1.9 x 7.0	1

MECHANISM EXPLODED VIEW

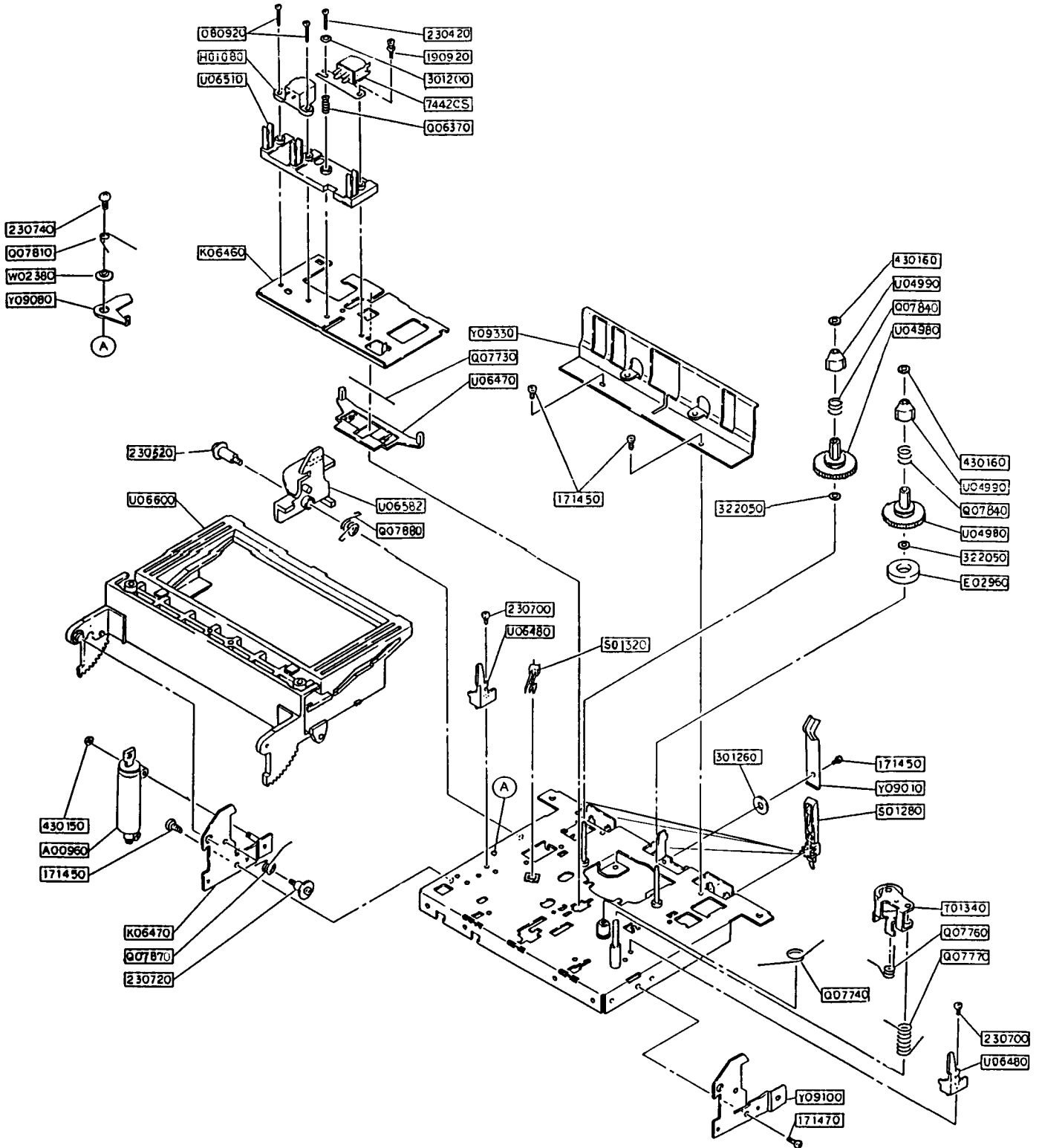

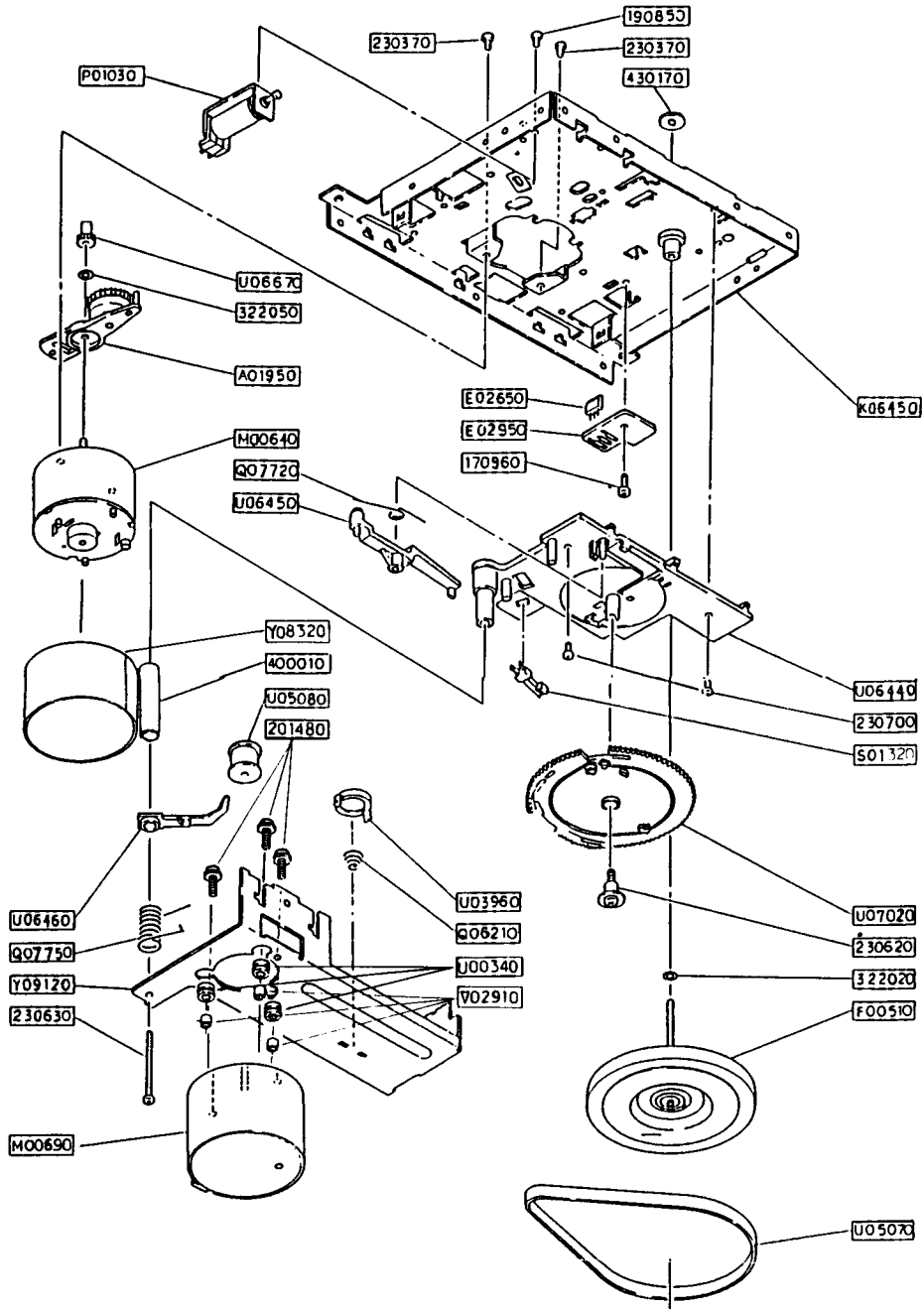

PARTS LIST

NAD-602 PARTS LIST

SYMBOL NO	REF. NO.	PART NO.	DESCRIPTION	Q'TY	
PCB ASS'Y		(5090509003)	NAD-602	WITH COMPONENTS	1
MAIN PCB ASS'Y		(5090409027)	NAD-602	WITH COMPONENTS	1
MAIN PCB BLOCK		(5090909081)	NAD-602		1
B200	5553138900	5553138900	MAIN PCB.	WITHOUT COMPONENTS	1
CAPACITORS					
C201, C202	5247112191	5247112191	CAP. CER.	120PFK +/-10% 50V	2
C203, C204	5247139191	5247139191	CAP. CER.	390PFK +/-10% 50V	2
C205, C206	5247112191	5247112191	CAP. CER.	120PFK +/-10% 50V	2
C207, C208	5213610091	5213610091	CAP. EL.	10uFM +/-20% 50V	2
C209, C210	5222139291	5222139291	CAP. POLY.	3900PFJ +/-5% 50V	2
C211, C212	5213610091	5213610091	CAP. EL.	10uFM +/-20% 50V	2
C213, C214	5222147391	5222147391	CAP. POLY.	4700PFJ +/-5% 50V	2
C215, C216	5222168291	5222168291	CAP. POLY.	6800PFJ +/-5% 50V	2
C217, C220	5222139391	5222139391	CAP. POLY.	3900PFJ +/-5% 50V	4
C221, C222	5213622991	5213622991	CAP. EL.	2.2uFM +/-20% 50V	2
C223	5213347091	5213347091	CAP. EL.	47uFM +/-20% 16V	1
C224	5213322191	5213322191	CAP. EL.	220uFM +/-20% 16V	1
C225	5213222191	5213222191	CAP. EL.	220uFM +/-20% 10V	1
C226	5213310191	5213310191	CAP. EL.	100uFM +/-20% 16V	1
C227- C230	5213622991	5213622991	CAP. EL.	2.2uFM +/-20% 50V	4
C231, C232	5213610091	5213610091	CAP. EL.	10uFM +/-20% 50V	2
C233, C234	5213233112	5213233112	CAP. EL.	330uFM +/-20% 10V	2
C235, C236	5213322091	5213322091	CAP. EL.	2.2uFM +/-20% 16V	2
C237- C240	5222122291	5222122291	CAP. POLY.	2200PFJ +/-5% 50V	4
C241, C242	5222139291	5222139291	CAP. POLY.	3900PFJ +/-5% 50V	2
C243, C244	5215002291	5215002291	CAP. EL.	0.47uFM +/-20% 50V	2
C245, C246	5215002191	5215002191	CAP. EL.	0.15uFM +/-20% 50V	2
C247, C248	5222115391	5222115391	CAP. POLY.	15000PFJ +/-5% 50V	2
C249, C250	5215000491	5215000491	CAP. EL.	0.22uFM +/-20% 50V	2
C251, C252	5222168391	5222168391	CAP. POLY.	6800PFJ +/-5% 50V	2
C253, C254	5222156391	5222156391	CAP. POLY.	56000PFJ +/-5% 50V	2
C255, C256	5222156291	5222156291	CAP. POLY.	5600PFJ +/-5% 50V	2
C257, C258	5222110391	5222110391	CAP. POLY.	10000PFJ +/-5% 50V	2
C259, C260	5213610091	5213610091	CAP. EL.	10uFM +/-20% 50V	2
C261	5213601091	5213601091	CAP. EL.	1uFM +/-20% 50V	1
C301, C302	5213601091	5213601091	CAP. EL.	1uFM +/-20% 50V	2
C303, C304	5213610091	5213610091	CAP. EL.	10uFM +/-20% 50V	2
C305, C306	5247118191	5247118191	CAP. CER.	180PFK +/-10% 50V	2
C307, C308	5222110291	5222110291	CAP. POLY.	1000PFJ +/-5% 50V	2
C309	5213310191	5213310191	CAP. EL.	100uFM +/-20% 16V	1
C501	5213510212	5213510212	CAP. EL.	1000uFM +/-20% 35V	2
C502	5213610091	5213610091	CAP. EL.	10uFM +/-20% 50V	1
C503	5213522201	5213522201	CAP. EL.	2200MFT 35V	1
C504	5213610091	5213610091	CAP. EL.	10uFM +/-20% 50V	1
C505	5213322212	5213322212	CAP. EL.	2200uFM +/-20% 16V	1
C506	5213347212	5213347212	CAP. EL.	4700uFM +/-20% 16V	1
C601, C602	5222133291	5222133291	CAP. POLY.	3300PFJ +/-5% 50V	2
C603, C604	5213647991	5213647991	CAP. EL.	4.7uFM +/-20% 50V	2
C605, C606	5213601091	5213601091	CAP. EL.	1uFM +/-20% 50V	2
C607, C608	5222110491	5222110491	CAP. POLY.	0.1MFJ +/-5% 50V	2
C609, C610	5222147291	5222147291	CAP. POLY.	4700PFJ +/-5% 50V	2
C611, C612	5213647991	5213647991	CAP. EL.	4.7uFM +/-20% 50V	2
C613, C614	5247147191	5247147191	CAP. CER.	470PFK +/-10% 50V	2
C615	5213547112	5213547112	CAP. EL.	470uFM +/-20% 35V	1
C616	5213347091	5213347091	CAP. EL.	47uFM +/-20% 16V	1
C617, C618	5222182291	5222182291	CAP. POLY.	8200PFJ +/-5% 50V	2
C619- C622	5222168291	5222168291	CAP. POLY.	6800PFJ +/-5% 50V	4
C623, C624	5247147191	5247147191	CAP. CER.	470PFK +/-10% 50V	2
C625, C626	5247010191	5247010191	CAP. CER.	100PFJ +/-5% 50V	1
C627, C628	5222139391	5222139391	CAP. POLY.	3900PFJ +/-5% 50V	1
C629, C630	5247068191	5247068191	CAP. CER.	680PFJ +/-5% 50V	2
C631, C632	5222122391	5222122391	CAP. POLY.	22000PFJ +/-5% 50V	2
C633, C634	5222110391	5222110391	CAP. POLY.	10000PFJ +/-5% 50V	2
C635	5236310401	5236310401	CAP. BARRIER LAYER	0.1uFZ +20/-80% 50V	1
C636	5213610091	5213610091	CAP. EL.	10uFM +/-20% 50V	1
C637	5231847391	5231847391	CAP. CER.	47000PFZ +20/-80% 50V	1
C638	5247110091	5247110091	CAP. CER.	10PFD 50V	1
C639	5213310191	5213310191	CAP. EL.	100uFM +/-20% 16V	1
C640	5213610091	5213610091	CAP. EL.	10uFM +/-20% 50V	1
C641	5213347091	5213347091	CAP. EL.	47uFM +/-20% 16V	1
C642, C643	5222133291	5222133291	CAP. POLY.	3300PFJ +/-5% 50V	2
C644	5222115391	5222115391	CAP. POLY.	15000PFJ +/-5% 50V	1
C645	5231810391	5231810391	CAP. CER.	10000PFZ +20/-80% 50V	1
C646	5222115391	5222115391	CAP. POLY.	15000PFJ +/-5% 50V	1
C647- C649	5231822391	5231822391	CAP. CER.	22000PFZ +20/-80% 50V	3
C701	5231810391	5231810391	CAP. CER.	10000PFZ +20/-80% 50V	1
C702	5213610091	5213610091	CAP. EL.	10uFM +/-20% 50V	1
C703	5213322091	5213322091	CAP. EL.	22uFM +/-20% 16V	1
C704	5231810391	5231810391	CAP. CER.	10000PFZ +20/-80% 50V	1
C705	5231847391	5231847391	CAP. CER.	47000PFZ +20/-80% 50V	1
DIODES					
D210, D202	1N4148	6613003030	DIODE SWITCHING	1N4148	2
D501- D507	1N4002	6611007230	DIODE RECTIFIER	1N4002 100V 1.0A	7

NAD-602 PARTS LIST

SYMBOL NO	REF. NO.	PART NO.	DESCRIPTION	Q'TY	
D508	HZ-6A-3	6615009757	DIODE ZENER	HZ-6A-3 5.4-5.7V	1
D509, D510	1N4002	6611007230	DIODE RECTIFIER	1N4002 100V 1.0A	2
D601, D606	1N4148	6613003030	DIODE SWITCHING	1N4148	6
D701-D705	1N4148	6613003030	DIODE SWITCHING	1N4148	5
D706	HZ-6A-3	6615009757	DIODE ZENER	HZ-6A-3 5.4-5.7V	1
D707	HZ-5C-2	6615009753	DIODE ZENER	HZ-5C-2 5-5.2V	1
D708	1N4148	6613003030	DIODE SWITCHING	1N4148	1
FUSES					
F501 *AH	5554309810 *AH	5554309810	FUSE, UL/CSA	125V 1A 5.2x20	1
F501 *B1, C	5554306800 *B1, C	5554306800	FUSE, T51	250V 1A 5.2x20	1
FC501	CQ-203S	5547032210	FUSE CLIP	CQ-203S	2
RELAY					
K201	5554502700	5554502700	RELAY	DS2Y-S-DC12V-UL	1
COILS					
L601, L602	5563106153	5563106153	CHOKO COIL	RC-875-153K 15MH +/-10%	2
L603, L604	5564402300	5564402300	TRAP COIL	TWS-384-556	2
L605, L606	5564314900	5564314900	VCA. COIL	TFO-0475	2
L607	5563105102	5563105102	CHOKO COIL	RC-855-102K 1000UH	1
L608	5564314800	5564314800	COIL OSC	1312-384-W049	1
IC. & TRANSISTOR					
Q201	NJM2068S	6646032600	IC DIGITAL TTL	NJM2068S 9PIN SIG	1
Q202-Q206	2SC1815-Y	6221015332	TR. NPN HF	2SC1815-Y TPE2	5
Q207	CX20188	6644000800	IC LINEAR BIPOLAR	CX20188	1
Q208	RN1209	6621010830	TR. NPN HF	RN1209 TPE2	4
Q209-Q212	2SC2458-GR	6621018403	TR. NPN HF	2SC2458-GR	4
Q301	NJM2068S	6646032600	IC DIGITAL TTL	NJM2068S 9PIN SIG	1
Q501	LM7815CT	6640007501	IC VOLTAGE REGULATOR	LM7815CT 15V TO-220 3P	1
Q501M	5545310600	5545310600	HEAT SINK	NAD-502	1
Q502	MJM7812A	6640002703	IC VOLTAGE REGULATOR	MJM7812A 12V 1A TO-220	1
Q503	2SD592A-R	6622020301	TR. NPN LF	2SD592A-R	1
Q507	2SC1815-Y	6221015332	TR. NPN HF	2SC1815-Y TPE2	1
Q601-Q608	2SC1815-Y	6221015332	TR. NPN HF	2SC1815-Y TPE2	8
Q609	NJM2068S	6646032600	IC DIGITAL TTL	NJM2068S 9PIN SIG	1
Q610	MC14052BCP	6645013301	IC DIGITAL CMOS	MC14052BCP	1
Q611	UPC1297CA	6644023600	IC LINEAR BIPOLAR	UPC1297CA	1
Q612, Q613	MC14052BCP	6645013301	IC DIGITAL CMOS	MC14052BCP	2
Q614	2SB621A-R	6624011701	TR. PNP LF	2SB621A-R	1
Q615	2SC1815-Y	6221015332	TR. NPN HF	2SC1815-Y TPE2	1
Q616, Q617	2SC1685-R	6621019300	TR. NPN LF	2SC1685-R	2
Q701	UPD-7556CS-107	6645003500	IC DIGITAL MOS	UPD-7556CS-107 24PIN DIP	1
Q702-Q704	RN2209	6623010230	TR. PNP HF	RN2209 TPE2	3
Q705	2SD592A-R	6622020301	TR. NPN LF	2SD592A-R	1
Q706	2SC2458-GR	6621018403	TR. NPN HF	2SC2458-GR	1
Q708, Q709	RN1209	6621010830	TR. NPN HF	RN1209 TPE2	1
Q710	RN2209	6623010230	TR. PNP HF	RN2209 TPE2	1
Q711	RN1209	6621010830	TR. NPN HF	RN1209 TPE2	1
Q712	RN2209	6623010230	TR. PNP HF	RN2209 TPE2	1
Q713	LB1645N	6644067100	IC LINEAR	LB1645N SIP10	1
Q714	2SC1815-Y	6221015332	TR. NPN HF	2SC1815-Y TPE2	1
Q715	RN2209	6623010230	TR. PNP HF	RN2209 TPE2	1
Q716, Q717	2SA1048-GR	6623007901	TR. PNP HF	2SA1048-GR	2
Q718	2SD592A-R	6622020301	TR. NPN LF	2SD592A-R	1
VAR.					
R217, R218	5162162220	5162162220	VAR. P/B EQ ADJ.	PN06FB223AR 22KM	2
R233, R234	5162162220	5162162220	VAR. P/B LEVEL ADJ.	PN06FB223AR 22KM	2
R242	5169020502	5169020502	VAR. PLAY TRIM	RK163121A161-10KCx2 (TT)	1
R302	5169010652	5169010652	VAR. BALANCE	RK163111E370-100KW	1
R601, R602	5162161720	5162161720	VAR. REC. LEVEL ADJ. (L&R)	PN06FB502AR F5x5 5K	2
R641, R642	5162161020	5162161020	VAR. PEAKING ADJ. TYPEI	PN06FB102AR 1.0K	2
R645, R646	5162161320	5162161320	VAR. PEAKING ADJ. TYPEII	PN06FB222AR F5x5 2.2K	2
R649, R650	5162161020	5162161020	VAR. PEAKING ADJ. TYPEIV	PN06FB102AR 1.0K	2
R663, R666	5162162520	5162162520	VAR. BIAS ADJ. TYPEI & II	PN06FB473AR 47KM	4
R669, R670	5162162520	5162162520	VAR. BIAS ADJ. TYPEIV	PN06FB473AR 47KM	2
COILS					
Z301, Z302	5564402200	5564402200	TRAP COIL	TFO-0512	2
TRANSFORMER PCB BLOCK					
T501	5561322300	(5090909082) 5561322300	POWER TRANSFORMER	NAD-602 NAD-602	1 1
DOLBY SW. PCB BLOCK					
P300A	5556103305	(5090909083) 5556103305	CONNECTOR	NAD-602 520011-0510	1 1
R301	5169020522	5169020522	VAR. REC. LEVEL	10KAx2 RK16312AR300	1
S201	5554440801	5554440801	ROTARY SWITCH, DOLBY NR	SRRZS43N27-TT3	1
POWER SW. PCB BLOCK					
S501	5554434610	(5090909084) 5554434610	POWER SWITCH	NAD-602 SPUN12C203-TT	1 1

NAD-602 PARTS LIST

SYMBOL NO	REF. NO.	PART NO.	DESCRIPTION	Q'TY	
LED/CTL PCB B900	ASS'Y 5553139000	(5090409028) 5553139000	LED/CTL PCB	WITH COMPONENTS WITHOUT COMPONENTS	1 1
CAPACITORS					
C901, C902	5213610891	5213610891	CAP. EL.	0.1uFM +/-20% 50V	2
C903-C905	5213610091	5213610091	CAP. EL.	10uFM +/-20% 50V	3
LEDS					
D901	6618009100	6618009100	DIODE LED	SE9411DH RED CLEAR	1
D902-D912	6618010900	6618010900	DIODE LED	SE9421D/LT6321-41 GREEN	11
D913, D914	6618009400	6618009400	DIODE LED	SE9431D DIFFUSED YELLOW	2
D915, D916	6618009100	6618009100	DIODE LED	SE9411DH RED CLEAR	2
D918	6618009100	6618009100	DIODE LED	SE9411DH RED CLEAR	1
IC & TRANSISTORS					
Q901, Q902	LB1408	6645007000	IC DIGITAL MOS	LB1408	2
Q903-Q906	2SC1815-Y	6221015332	TR. NPN HF	2SC1815-Y TPE2	4
SWITCHES					
S701-S706	5054512940	5054512940	SWITCH TACT SPST	KHH10902 DC12V 50mA F=100GF	6

PACKING DIAGRAM

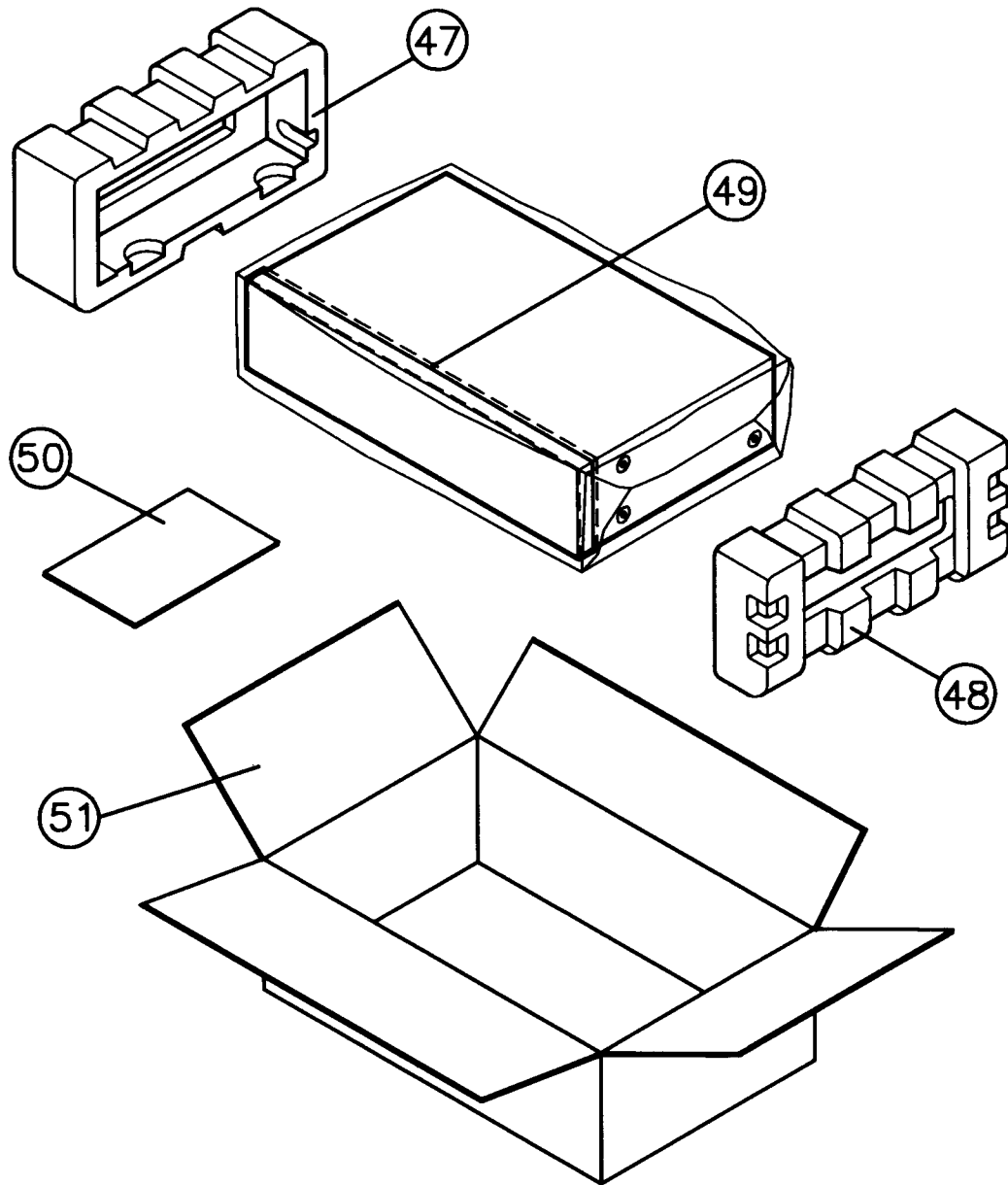

ITEM	PARTS NO.	DESCRIPTION	Q'TY
47	9521040155	EPS PAD-L	1
48	9521040255	EPS PAD-R	1
49	9530100155	EPE BAG	1
50	5535122585	OWNERS MANUAL	1
51	9511040155	RS CARTON	1

NOTES:

SERVICE MANUAL

602

**CASSETTE
DECK**

NAD ELECTRONICS
LONDON