



# SERVICE MANUAL

7225PE - F722503001  
7020i - F702004076

# 7225PE

# 7020i

## AM/FM RECEIVERS

## CONTENTS 7225PE/7020I

REAR / FRONT PANEL CONNECTIONS	PAGE 3
SPECIFICATIONS	PAGE 4 — 5
ALIGNMENT METHOD	PAGE 6 — 9
INSTRUMENT SET-UP	PAGE 10
AMPLIFIER PCB LAYOUT AND WIRING DIAGRAM	PAGE 11
PCB LAYOUT AND WIRING DIAGRAM, TUNER	PAGE 12
AMPLIFIER PCB LAYOUT	PAGE 13
TUNER PCB LAYOUT	PAGE 14
SCHEMATIC DIAGRAM NAD 7225PE	PAGE 15
SCHEMATIC DIAGRAM NAD 7020I	PAGE 16
TUNER CIRCUIT DIAGRAM	PAGE 17
PARTS LIST — SCHEMATIC DIAGRAM	PAGE 18 — 24
EXPLODED VIEW	PAGE 25
PARTS LIST — EXPLODED VIEW	PAGE 26 — 27
PACKING DIAGRAM	PAGE 28

Proprietary information for servicing purposes only. The information given herein may not be used commercially without the prior written agreement of NAD Electronics Ltd. England.

## REAR PANEL

- |                      |                      |                     |
|----------------------|----------------------|---------------------|
| 1. AC Line Cord      | 6. Antenna Terminals | 10. CD Input        |
| 2. AC Outlets        | 7. Ground            | 11. Tape In/Out     |
| 3. Speaker Impedance | 8. Phono Input       | 12. Preamp Out/Main |
| 4. Speakers A        | 9. Video Sound Input | 13. Soft Clipping   |
| 5. Speakers B        |                      |                     |

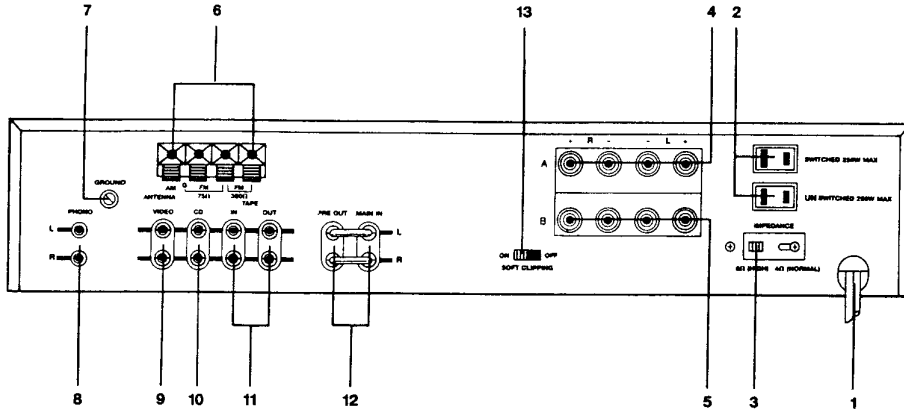

## FRONT PANEL

- |                   |                    |                           |
|-------------------|--------------------|---------------------------|
| 1. Power          | 7. Tape Monitor    | 13. Center-tune Indicator |
| 2. Phones         | 8. Input Selector  | 14. FM Stereo Indicator   |
| 3. Extra Speakers | 9. Mono            | 15. Tuning Pre-sets       |
| 4. Bass           | 10. Loudness       | 16. Memory Enter          |
| 5. Treble         | 11. Volume         | 17. Search Mode           |
| 6. Balance        | 12. Tuning Display | 18. Up/Down Tuning        |

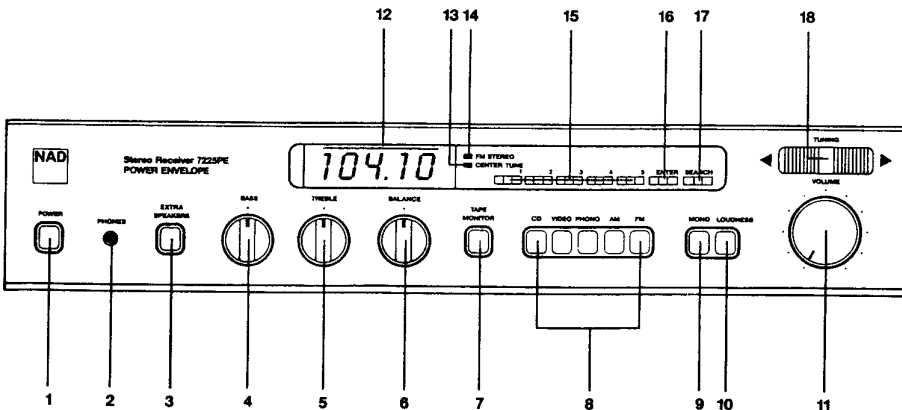

Specifications are measured in accordance with EIA Standard RS-490 (IHF A-202) for amplifiers and ANSI-IEEE Standard 185 (1975), i.e. IHF T-200, for tuners. Amplifier measurements referred to 8 ohms are taken with the Speaker Impedance selector set to 8 ohms (High). Measurements for 4 and 2 ohms are taken with impedance selector at 4 ohms (Normal).

## SPECIFICATIONS

**CONTINUOUS AVERAGE POWER OUTPUT INTO 8 OHMS**  
(Min. power per channel, 20Hz-20KHz, both channels driven, with no more than rated distortion)

**Rated Distortion (THD, 20Hz-20KHz)**

**Clipping power at 8 ohms, 1KHz**  
(maximum continuous power per channel)

**IHF dynamic headroom at 8 ohms**

**IHF dynamic power**  
(maximum short term power per channel)

**Damping factor (ref. 8 ohms, 50Hz)**

### 7020i

20W (13dBW)

0.03%

30W

+3dB

8 ohms 40W (16dBW)  
4 ohms 40W (16dBW)  
2 ohms 50W (17dBW)

>30

### 7225PE

25W (14dBW)

0.03%

40W

+4dB

60W (18dBW)  
85W (19dBW)  
90W (19.5dBW)

>50

## PREAMPLIFIER SECTION

### PHONO INPUT

**Input impedance**

**Input sensitivity, 1KHz**

**Signal/Noise ratio**  
(A-weighted with cartridge connected)

**THD (20Hz-20KHz) and IM distortion**

**RIAA response accuracy**

**LINE LEVEL INPUTS (Tuner, CD, Aux, Video, Tape)**

**Input impedance**

**Input sensitivity**

**Signal/Noise ratio, A-weighted**

**Frequency response, 20Hz-20KHz**

**Infrasonic filter**

R=47Kohms, C=100pF

2.4mV ref. 20W

75dB ref. 5mV

<0.04%

±0.5dB

R=40Kohms, C=100pF

150mV ref. 20W

87dB ref. 1W  
100dB ref. 20W

+0.5, -1.0dB

-3dB at 12Hz, 18dB/octave (fixed)

R=47Kohms, C=100pF

2.5mV ref. 25W

75dB ref. 5mV

<0.04%

±0.5dB

R=40Kohms, C=100pF

160mV ref. 25W

85dB ref. 1W  
99dB ref. 25W

+0.5, -1.0dB

-3dB at 15Hz, 24dB/octave (fixed)

## LINE LEVEL OUTPUTS

**Output impedance**

**Maximum output level**

Pre Out 600 ohms  
Tape Source Z + 2000 ohms  
Phones 220 ohms

Pre Out 12V  
Tape 10V  
Phones >10V into 600 ohms  
>500mV into 8 ohms

600 ohms  
Source Z + 1000 ohms  
220 ohms

12V  
10V  
>10V into 600 ohms  
>500mV into 8 ohms

## CONTROLS

**Treble**

**Bass**

±7dB at 10KHz

±10dB at 50Hz

±7dB at 10KHz

±10dB at 50Hz

## FM TUNER SECTION

### FM TUNER SECTION

Input sensitivity	<b>Mono, —30dB THD+N</b> <b>Mono, 50dB S/N</b> <b>Stereo, 50dB S/N</b> <b>Stereo, 60dB S/N</b>	11.3dBf (2.0uV/300 ohms) 15dBf (3.0uV/300 ohms) 37dBf (40uV/300 ohms) 47dBf (120uV/300 ohms)	11.3dBf (2.0uV/300 ohms) 15dBf (3.0uV/300 ohms) 37dBf (40uV/300 ohms) 47dBf (120uV/300 ohms)
Capture ratio (45 and 65dBf)		<1.5dB	<1.5dB
Selectivity, alternate channel		58dB	58dB
Subcarrier suppression (19 and 38KHz)		60dB	60dB
THD at 100% modulation	<b>Mono, 1KHz</b> <b>Stereo, 1KHz</b>	0.1% 0.1%	0.1% 0.1%
Signal/Noise ratio (at 65dBf, IHF weighted)	<b>Mono</b> <b>Stereo</b>	>80dB >74dB	>80dB >74dB
Frequency response, 30Hz-15KHz		±0.5dB	±0.5dB
Stereo separation, 1KHz		45dB	45dB

## AM TUNER SECTION

Usable sensitivity		5uV	5uV
Selectivity		30dB	30dB
Image rejection		45dB	45dB
Signal/Noise ratio (30% modulation, 50mV input)		45dB	45dB
THD		0.5%	0.5%

## PHYSICAL SPECIFICATIONS

Dimensions (Width×Height×Depth)	42×9.1×27.3cm (16.5×3.6×10.75in.)	42×9.1×27.3cm (16.5×3.6×10.75in.)
Net weight	5.5kg (12lb 2oz)	5.5kg (12lb 2oz)
Shipping weight	6.8kg (15lbs)	6.8kg (15lbs)
Power consumption at 120, 220 or 240VAC 50/60Hz	150W	150W

# MAIN AMPLIFIER ADJUSTMENT

## IMPORTANT NOTES:

- 1) Before adjusting, remove input signal and load, and set Speaker impedance switch to 8 ohms (reset to 4 ohms when finished).
- 2) These adjustments are always necessary after repair to main amplifier.
- 3) After repair, it is recommended to use current limiter (30-70W lightbulb) in mains line, for initial turn-on.

## A. CENTER VOLTAGE ADJUSTMENT

1. Connect DMM across L channel (R channel) output terminals.
2. Turn on, and adjust R-411 (R-412) for reading of  $0V \pm 30$  mVDC.

## B. IDLE CURRENT ADJUSTMENT

1. Remove solder short across R-455 and R-456.
2. Connect DMM across P-403(—) and P-404 (+).
3. Turn on and adjust R-443 for reading of  $28$  mV  $\pm 2$  mVDC.
4. Repeat, using P-405(+) and P-406(—), adjust R-444.

## C. FINAL ADJUSTMENT

1. Leave power on for a minimum of 5 minutes with no signal connected.
2. Repeat center voltage and idle current adjustments.
3. **WHEN FINISHED, REPLACE SOLDER SHORT ACROSS R-455 AND R-456.**

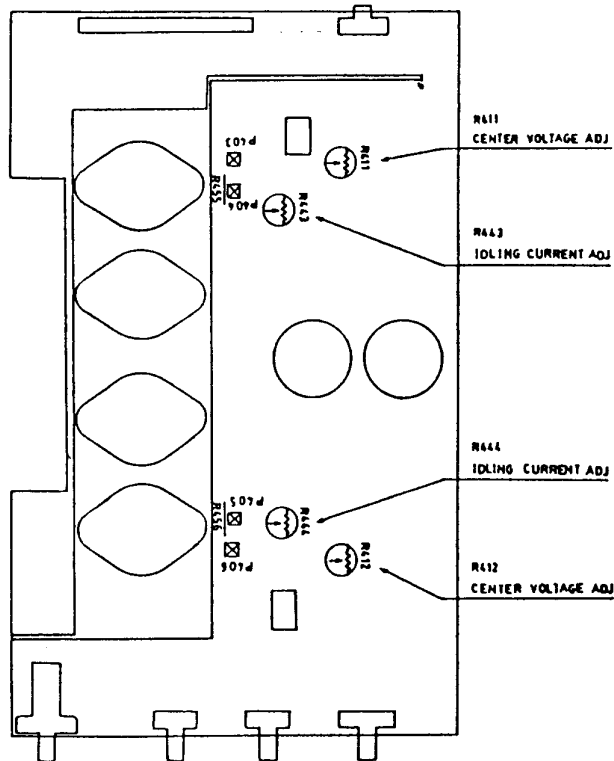

AMPLIFIER ADJUSTMENT POINTS

# FM ALIGNMENT

## I. NECESSARY INSTRUMENTATION

1. FM SIGNAL GENERATOR ( $< 0.03\%$  THD)
2. STEREO MODULATOR ( $< 0.03\%$  THD)
3. 50/75 OHMS DUMMY ANTENNA (If needed by generator)
4. DIGITAL VOLTMETER (DVM)
5. DISTORTION METER ( $< 0.1\%$  resolution)
6. AC VOLTMETER
7. OSCILLOSCOPE ( $< 5$  mV sensitivity)
8. IHF FILTER

## II. IMPORTANT NOTES

1. All equipment must be capable of measuring better than specification of unit under test.
2. 1 KHz modulating signal,  $\pm 75$  KHz deviation, mono unless otherwise stated.
3. All RF levels quoted are at 75 OHMS impedance. If at 300 OHMS impedance, add 6 dBu from figures.
4. Enter the following frequencies: 98, 87.5, 108, 90 and 106 MHz.

## III. PREPARATION

1. Turn I1 (IF) counterclockwise until core is near the top.
2. Turn I102 (FM detector primary) counterclockwise until core is near the top.
3. Turn I103 (FM detector secondary) counterclockwise until core is near the top.

## IV. PROCEDURE

### A. OSCILLATOR TUNING VOLTAGE

1. Connect DVM between P123 and ground.
2. Set tuner to 87.5 MHz and check DVM for a reading of  $3 \text{ VDC} \pm 0.5\text{V}$  ( $1.6 \text{ VDC} \pm 0.3\text{V}$  for C1 version).
3. Set tuner to 108 MHz and check DVM for a reading of  $20.5 \text{ VDC} \pm 0.5\text{V}$  ( $8 \text{ VDC} \pm 0.5\text{V}$  for C1 version).

If either of the above is out of tolerance, adjust L8 (oscillator coil) until both readings are within tolerance.

### B. IF CENTER ADJUSTMENT

1. Connect DVM between P112 and P113.
2. Apply 10.7 MHz (90 dBu) VIA 1K OHM resistor to P111.
3. Adjust I102 (clockwise) for  $0 \text{ VDC} \pm 50 \text{ mV}$  reading on DVM.
4. Adjust I103 (clockwise) until minimum THD is achieved at audio O/P.
5. Repeat (3) and (4) until no further improvement can be made.

**NOTE:** When adjusting I103 two nulls can be found. Adjust until the second one is found as this has lower THD. Correct position of core is normally just above the metal casing.

### C. SYNTHESIZER / IF TRACKING

1. Maintain connection of DVM and disconnect 10.7 MHz TAP at P111.
2. Apply 98 MHz (54dBu) to 75 OHMS antenna input and tune to 98 MHz.
3. Adjust C917 for  $0 \text{ VDC} \pm 20 \text{ mV}$  reading on DVM.
4. Fine adjust I103 for minimum THD.
5. Repeat (3) and (4) until no further improvement can be made.

### D. I1 ALIGNMENT

1. Connect DVM between wiper of R117 (right of R159) and ground.
2. Turn R117 fully counterclockwise.
3. Apply 98 MHz (6dBu) to antenna input.
4. Carefully adjust I1 to obtain maximum reading on DVM. There should only be one maximum.

### E. RF ADJUSTMENT

1. Apply 98 MHz (6dBu) to antenna input.
2. Check if THD is better than 3%. If not, proceed to (3).
3. Adjust L2, L4 and L5 by squeezing or stretching using a non-metallic tool until THD is better than 3%.
4. Repeat (3) at 90 MHz and 106 MHz and re-adjust until THD is within 3% at 7dBu for both frequencies and 6 dBu for 98 MHz.

### F. AUTOSEARCH LEVEL

1. Connect DVM between wiper of R117 (right to R159) and ground.
2. Apply 98 MHz (60dBu) to antenna input and tune to 98 MHz.
3. Adjust R117 to get  $1.05 \text{ VDC} \pm 0.01 \text{ V}$  reading on DVM.
4. Check if autosearch operation is working properly at antenna signal level of 26dBu (20uV).

### G. STEREO SEPARATION AND PILOT SUPPRESSION

1. Modulate L-only at 98 MHz (60dBu) and adjust R127 for minimum output on right channel.
2. Modulate R-only and adjust R127 for minimum output on left channel.
3. Repeat (1) and (2) until readings are the same and within specs.
4. Cancel stereo modulation and leave pilot tone.
5. Adjust Z105 and Z106 for minimum output on left and right channels, respectively.

# AM ALIGNMENT

## I. IMPORTANT NOTES

1. 1 KHz 30% modulation.
2. 22 pF connected between signal generator and AM antenna terminal. Capacitor should be as close as possible to antenna terminal.
3. Enter the following frequencies: 600 (603)KHz, 1000 (999)KHz and 1400 (1404)KHz.

## II. PROCEDURE

### A. OSCILLATOR TUNING VOLTAGE

1. Connect DVM between P123 and ground.
2. Set tuner to 600 (603)KHz and adjust L102 for  $1.75V \pm 50mV$  reading on DVM.

### B. IF ADJUSTMENT

1. Apply 1000 (999)KHz 20dBu to antenna terminals.
2. Adjust I101 for maximum reading on audio output.

### C. TRACKING ADJUSTMENT

1. Apply 600 (603)KHz 20dBu to antenna terminals.
2. Adjust L101 for maximum reading on audio output.
3. Apply 1400 (1404)KHz 20dBu to antenna terminals.
4. Adjust C138 for maximum reading on audio output.
5. Repeat (1) to (4) until no further improvement can be made.

### D. AUTOSEARCH / TUNER LEVEL

1. Apply 1000 (999)KHz 20 dBu.
2. Adjust R116 so that tune LED just lights fully.

# TUNER ADJUSTMENT POINTS

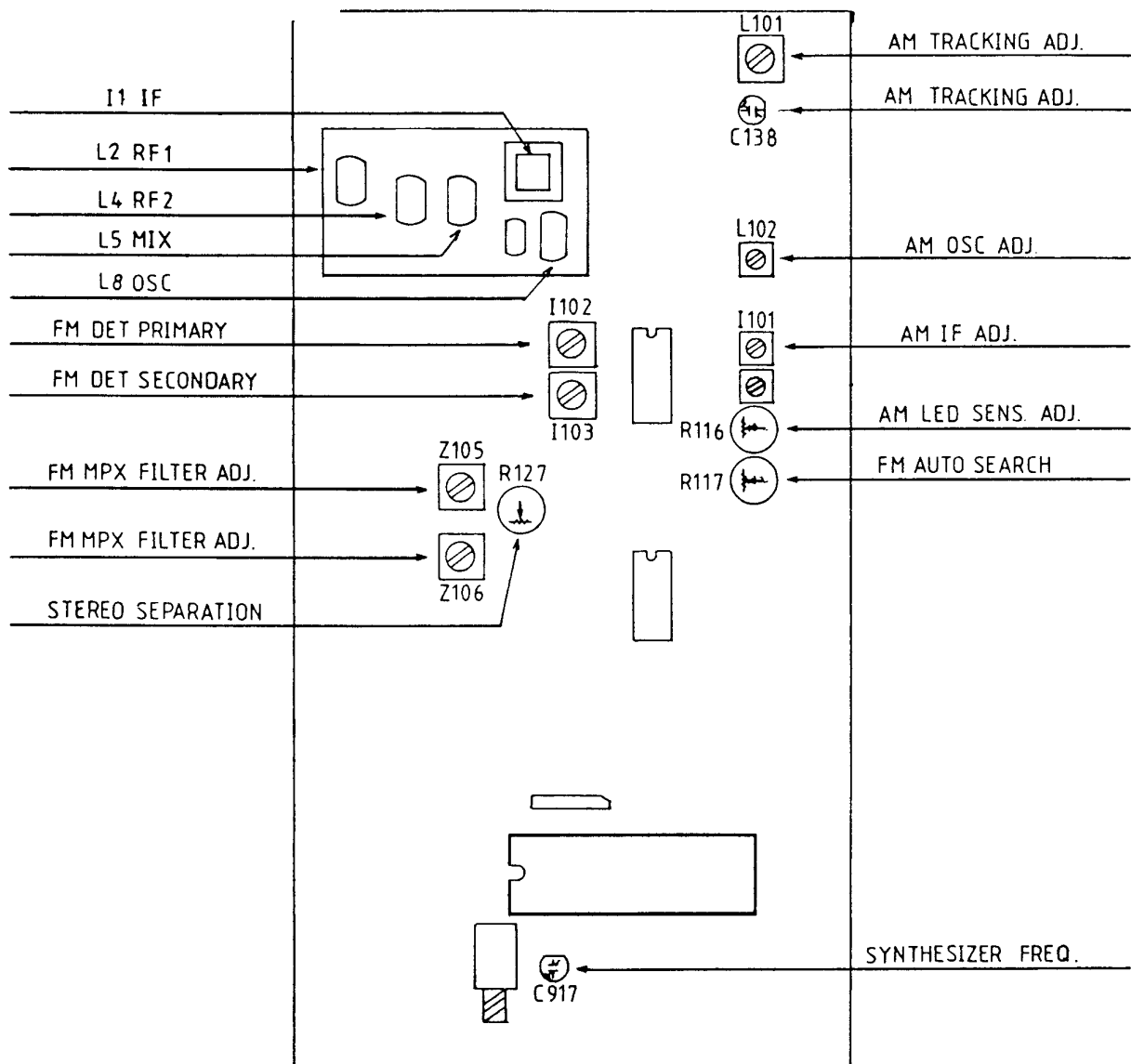



# INSTRUMENT SET - UP

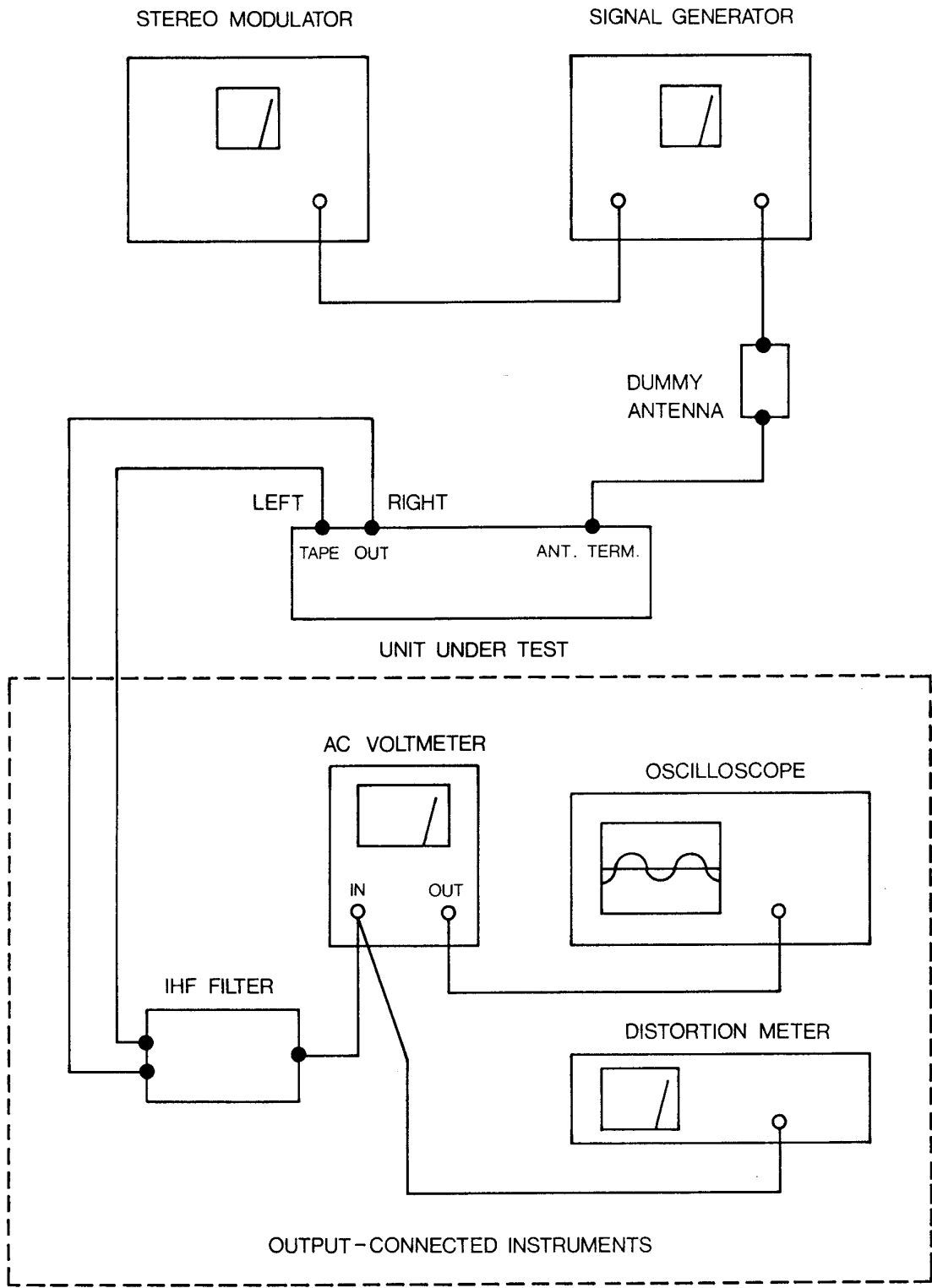

For Versions A, A1.

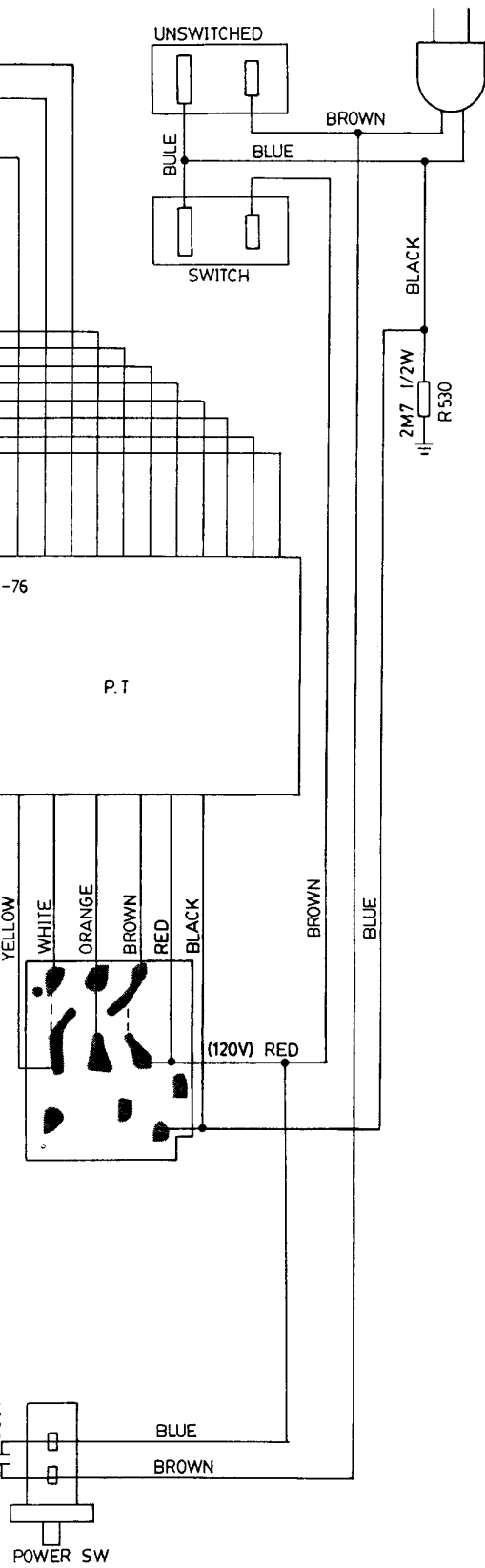

For Versions B, B1, C, C1.

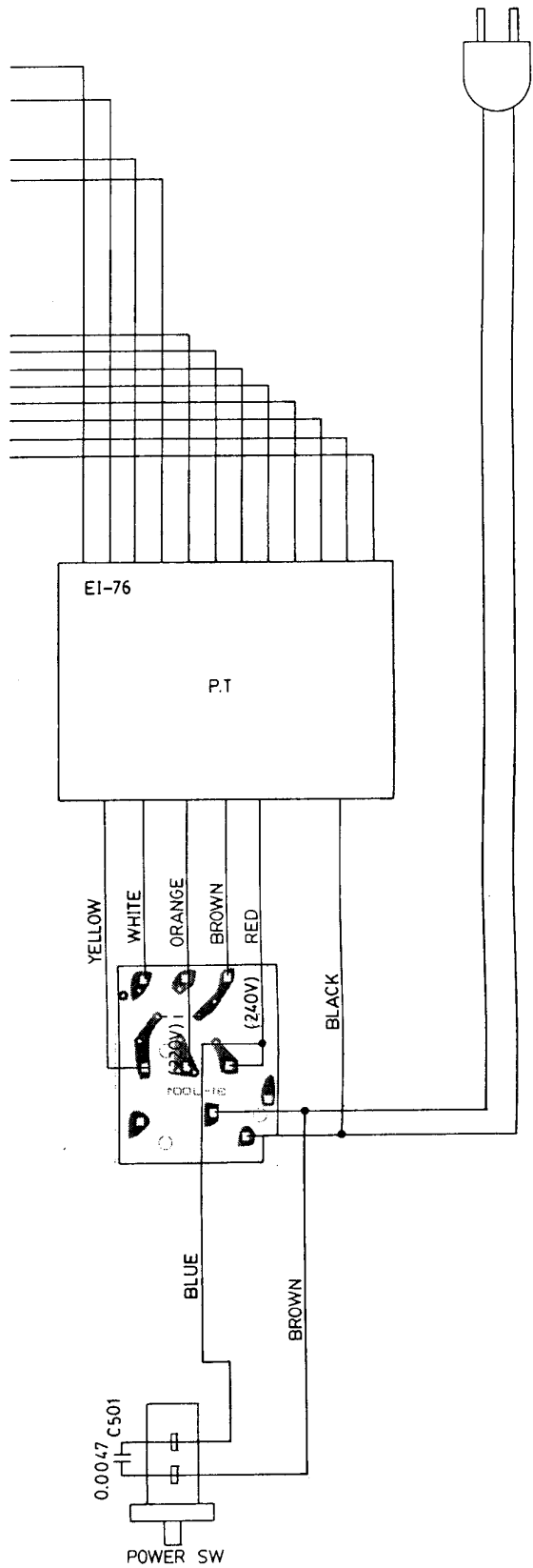

SCHMATIC DIAGRAM NAD 7225PE AMPLIFIER

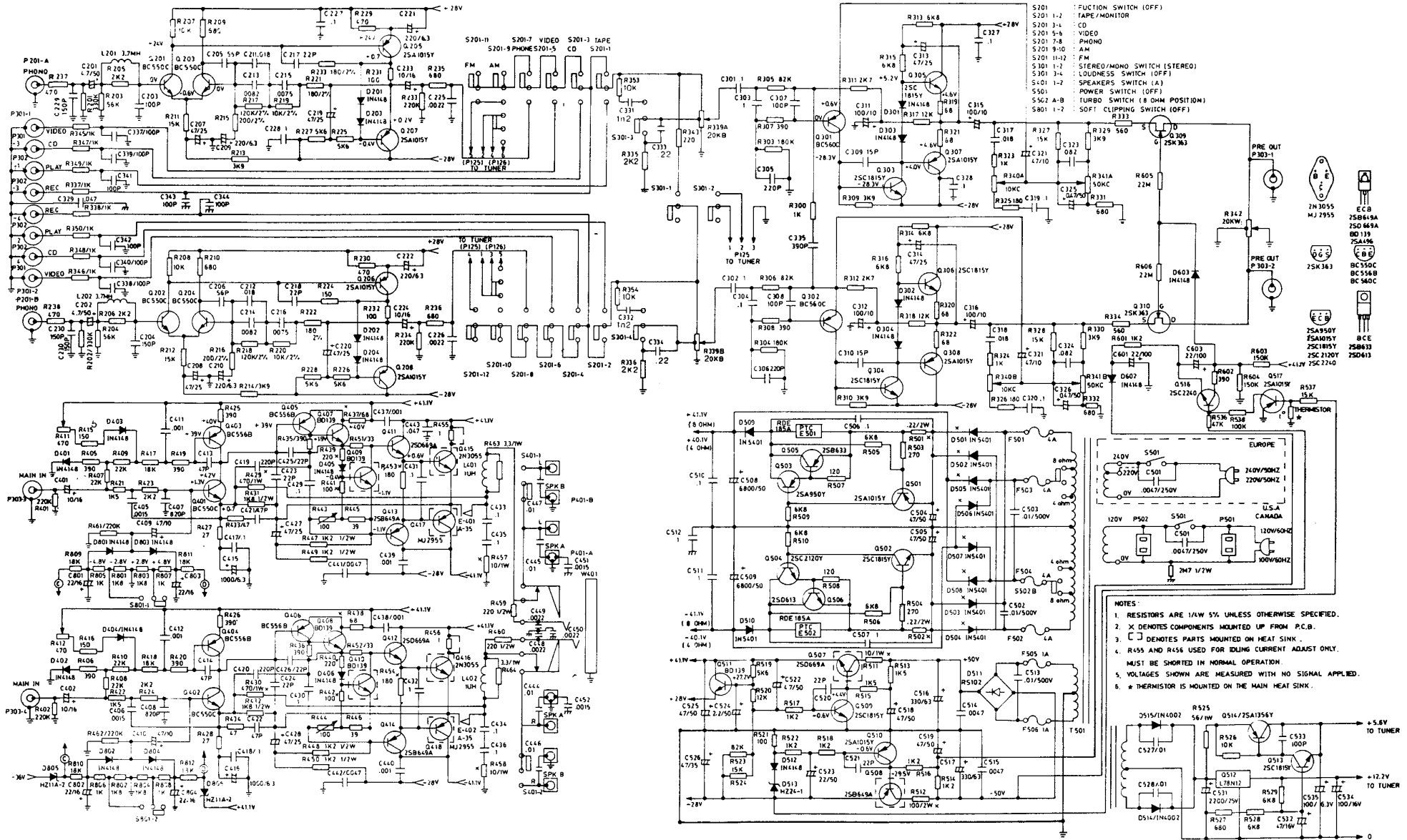

- NOTES:
1. RESISTORS ARE 1/4W 5% UNLESS OTHERWISE SPECIFIED.
  2. X DENOTES COMPONENTS MOUNTED UP FROM P.C.B.
  3. C DENOTES PARTS MOUNTED ON HEAT SINK.
  4. R-55 AND R-56 USED FOR IDLING CURRENT ADJUST ONLY. MUST BE SHORTED IN NORMAL OPERATION.
  5. VOLTAGES SHOWN ARE MEASURED WITH NO SIGNAL APPLIED.
  6. \* THERMISTOR IS MOUNTED ON THE MAIN HEAT SINK.

SCHEMATIC DIAGRAM NAD 70201

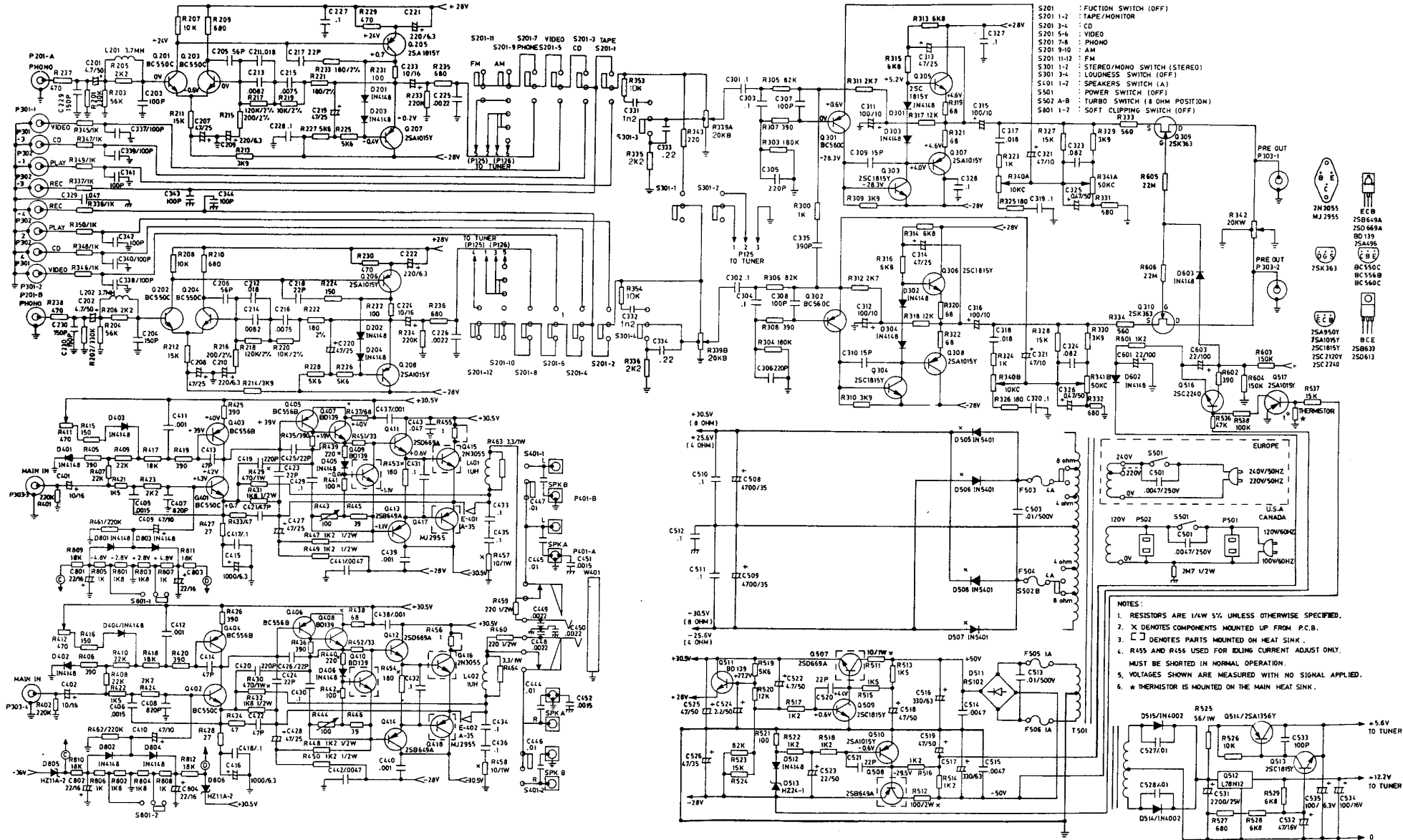

- FUNCTION SWITCH (OFF)
- S201-1-1 TAPE/MONITOR
  - S201-1-2 CD
  - S201-1-3 VIDEO
  - S201-1-4 PHONO
  - S201-1-5 AM
  - S201-1-6 FM
  - S201-1-7 STEREO/MONO SWITCH (STEREO)
  - S201-1-8 LOUDNESS SWITCH (OFF)
  - S201-1-9 SPEAKERS SWITCH (A)
  - S201-1-10 POWER SWITCH (OFF)
  - S201-1-11 TURBO SWITCH (8 OHM POSITION)
  - S201-1-12 SOFT CLIPPING SWITCH (OFF)

- NOTES:
1. RESISTORS ARE 1/4W 5% UNLESS OTHERWISE SPECIFIED.
  2. X DENOTES COMPONENTS MOUNTED UP FROM P.C.B.
  3. □ DENOTES PARTS MOUNTED ON HEAT SINK.
  4. R455 AND R156 USED FOR IDLING CURRENT ADJUST ONLY. MUST BE SHORTED IN NORMAL OPERATION.
  5. VOLTAGES SHOWN ARE MEASURED WITH NO SIGNAL APPLIED.
  6. \* THERMISTOR IS MOUNTED ON THE MAIN HEAT SINK.

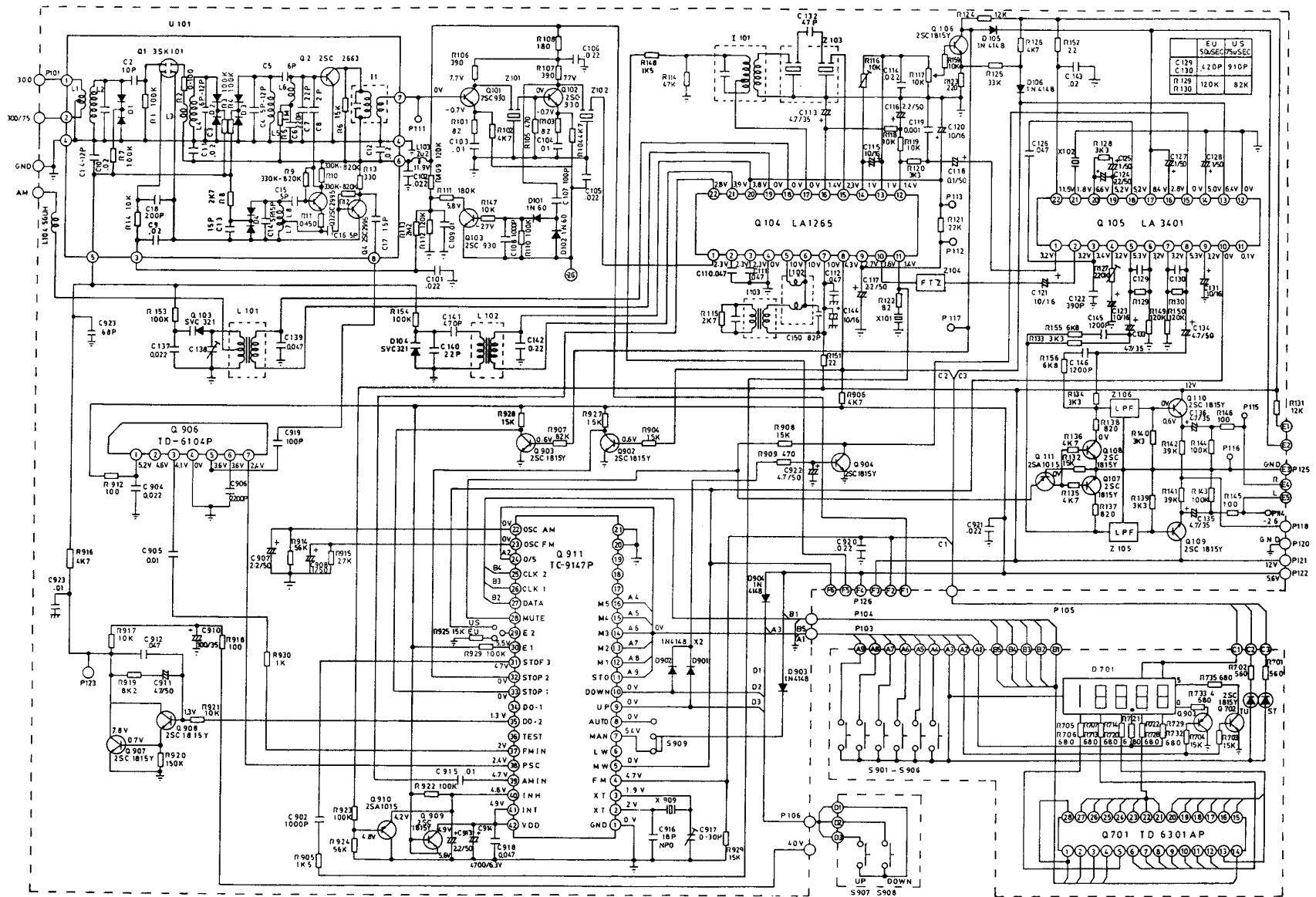

SYMBOL NO.		PART NO.	DESCRIPTION	REF.
C101	C102	571-0Z73200	Cer. Cap.	0.02 uF +80-20% 50V
C103	C104	571-0Z73100	Cer. Cap.	0.01 uF +80-20 50V
C105	C106	571-0Z73200	Cer. Cap.	0.02 uF +80-20% 50V
C107		571-0J71100	Cer. Cap.	100 PF + -5% 50V
C108		571-0Z72100	Cer. Cap.	0.001 uF +80-20% 50V
C109		571-0Z73100	Cer. Cap.	0.01 uF +80-20 50V
C110	C111	571-0M73470	Cer. Cap.	0.047 uF + -20% 50V
C112		571-0M73470	Cer. Cap.	0.047 uF + -20% 50V
C113		573-11M7547	Ele. Cap.	4.7 uF + -20% 50V
C114		571-0Z73200	Cer. Cap.	0.02 uF +80-20% 50V
C115		573-11M4610	Ele. Cap.	10 uF + -20% 16V
C116	C117	573-11M7522	Ele. Cap.	2.2 uF + -20% 50V
C118		573-11M7410	Ele. Cap.	0.1 uF + -20% 50V
C119		571-0Z73100	Cer. Cap.	0.01 uF +80-20 50V
C120	C121	573-11M4610	Ele. Cap.	10 uF + -20% 16V
C122		571-OK71390	Cer. Cap.	390 PF + -10% 50V
C123		573-11M4610	Ele. Cap.	10 uF + -20% 16V
C124		573-11M7422	Ele. Cap.	0.22 uF + -20V 50V
C125		573-11M7510	Ele. Cap.	1 uF + -20% 50V
C126		572-K05347	Mylar Cap.	0.047 uF + -10% 50V
C127	C128	573-11M7510	Ele. Cap.	1 uF + -20% 50V
C129	C130	575-31J5142	Poly. Cap.	420 PF + -5% 25V
C129	C130	575-31J5191	Poly. Cap.	910 PF + -5% 25V
C132		571-1J70470	Cer. Cap.	47 PF + -5% 50V
C133	C134	573-11M7547	Ele. Cap.	4.7 uF + -20% 50V
C135	C136	573-11M7547	Ele. Cap.	4.7 uF + -20% 50V
C137		571-0Z73200	Cer. Cap.	0.02 uF +80-20% 50V
C138		516-2030S1	Trimer	30 PF
C139		571-0M73470	Cer. Cap.	0.047 uF + -20% 50V
C140		571-1J70220	Cer. Cap.	22 PF + -5% 50V
C141		575-31J5147	Poly. Cap.	470 PF + -5% 25V
C142	C143	571-0Z73200	Cer. Cap.	0.02 uF +80-20% 50V
C144		573-11M4647	Elect. Cap.	47 uF + -20% 20V
C145	C146	572-K05212	Mylar Cap.	0.0012 uF + -10% 50V
C201	C202	573-11M7547	Ele. Cap.	4.7 uF + -20% 50V
C203	C204	571-0J71150	Cer. Cap.	150 PF + -5% 50V
C205	C206	571-0J70560	Cer. Cap.	56 PF + -5% 50V
C207	C208	573-11M5647	Ele. Cap.	47 uF + -20% 25V
C209	C210	573-11M3722	Ele. Cap.	220 uF + -20% 10V
C211	C212	572-J10318	Mylar Cap.	0.018 uF + -5% 100V
C213	C214	572-J10282	Mylar Cap.	0.0082 uF + -5% 100V
C215	C216	572-J10275	Mylar Cap.	0.0075 uF + -5% 100V
C217	C218	571-0J70220	Cer. Cap.	22 PF + -5% 50V
C219	C220	573-11M5647	Ele. Cap.	47 uF + -20% 25V
C221	C222	573-11M3722	Ele. Cap.	220 uF + -20% 10V
C223	C224	573-11M4610	Ele. Cap.	10 uF + -20% 16V
C225	C226	572-J10222	Mylar Cap.	0.0022 uF + -5% 100V
C227	C228	571-0Z74100	Cer. Cap.	0.1 uF +80-20% 50V
C229	C230	571-0J71150	Cer. Cap.	150 PF + -5% 50V
C301	C302	572-J10410	Mylar Cap.	0.1 uF + -5% 100V
C303	C304	572-J10410	Mylar Cap.	0.1 uF + -5% 100V
C305	C306	571-0J71220	Cer. Cap.	220 PF + -5% 50V
C307	C308	571-0J71100	Cer. Cap.	100 PF + -5% 50V
C309	C310	571-0J70150	Cer. Cap.	15 PF + -5% 50V
C311	C312	573-11M3710	Ele. Cap.	100 uF + -20% 10V
C313	C314	573-11M5647	Ele. Cap.	47 uF + -20% 25V
C315	C316	573-11M3710	Ele. Cap.	100 uF + -20% 10V
C317	C318	572-J10318	Mylar Cap.	0.018 uF + -5% 100V
C319	C320	572-J10410	Mylar Cap.	0.01 uF + -5% 100V
C321	C322	573-11M3647	Ele. Cap.	47 uF + -20% 10V
C323	C324	572-J10382	Mylar Cap.	0.082 uF + -5% 100V
C325	C326	573-11M7447	Ele. Cap.	0.47 uF + -20% 50V
C327	C328	571-0Z74100	Cer. Cap.	0.1 uF +80-20% 50V
C329	C443	571-0Z73470	Cer. Cap.	0.047 uF +80-20% 50V
C335		571-OK71390	Cer. Cap.	390 PF + -10% 50V
C331	C332	571-K05212	Mylar Cap.	0.0012 uF + -10% 50V
C333	C334	572-J10422	Mylar Cap.	0.22 uF + -5% 100V
C337	C338	571-0J71100	Cer. Cap.	100 PF + -5% 50V
C339	C340	571-0J71100	Cer. Cap.	100 PF + -5% 50V
C341	C342	571-0J71100	Cer. Cap.	100 PF + -5% 50V
C343	C344	571-0J71100	Cer. Cap.	100 PF + -5% 50V
C401	C402	573-11M4610	Ele. Cap.	10 uF + -20% 16V
C405	C406	572-J10215	Mylar Cap.	0.0015 uF + -5% 100V
C407	C408	571-0J71820	Cer. Cap.	820 PF + -5% 50V
C409	C410	573-11M3647	Ele. Cap.	47 uF + -20% 10V
C411	C412	572-J10210	Mylar Cap.	0.001 uF + -5% 50V
C413	C414	571-0J70470	Cer. Cap.	47 PF + -5% 50V

B/B1 C/C1  
A/A1  
NPO

NPO

SYMBOL NO.		PART NO.	DESCRIPTION	REF.
C415	C416	573-11M3810	Ele.Cap.	1000 uF + -20% 10V
C417	C418	572-J10410	Mylar Cap.	0.1 uF + -5% 50V
C419	C420	571-0J71220	Cer.Cap.	220 PF + -5% 50V
C421	C422	571-0J70470	Cer.Cap.	47 PF + -5% 50V
C423	C424	571-0J70220	Cer.Cap.	22 PF + -5% 50V
C425	C426	571-0J70220	Cer.Cap.	22 PF + -5% 50V
C427	C428	573-11M5647	Ele.Cap.	47 uF + -20% 25V
C429	C430	572-J10410	Mylar Cap.	0.1 uF + -5% 100V
C431	C432	572-J10410	Mylar Cap.	0.1 uF + -5% 100V
C433	C434	571-0Z74100	Cer.Cap.	0.1 uF + 80-20% 50V
C435	C436	571-0Z74100	Cer.Cap.	0.1 uF + 80-20% 50V
C437	C438	571-0M72100	Cer.Cap.	0.001 uF + -20% 50V
C439	C440	571-0M72100	Cer.Cap.	0.001 uF + -20% 50V
C441	C442	571-0K72500	Cer.Cap.	0.005 uF + -10% 50V
C444	C445	571-0K73100	Cer.Cap.	0.01 uF + -10% 50V
C446	C447	571-0J72150	Cer.Cap.	0.0015 uF + -5% 50V
C448	C449	571-0J72220	Cer.Cap.	0.0022 uF + -5% 50V
C450		571-0J72220	Cer.Cap.	0.0022 uF + -5% 50V
C501		571-0ME2470	Cer.Cap.	0.0047 uF + -20% 400V
C502	C503	572-M50310	Mylar Cap.	0.01 uF + -5% 500V
C504	C505	573-11M7647	Ele.Cap.	47 uF + -20% 50V 7225
C506	C507	571-0Z74100	Cer.Cap.	0.1 uF + 80-20% 50V 7225
C508	C509	573-11M6847	Ele.Cap.	4700 uF + -20% 35V 7020
C508	C509	573-11T7868	Ele.Cap.	6800 uF + 50-10% 50V 7225
C510	C511	571-0ZA4100	Cer.Cap.	0.1 uF + 80-20% 100V
C512		571-0Z74100	Cer.Cap.	0.1 uF + 80-20% 50V
C513		572-M50310	Mylar Cap.	0.01 uF + -5% 500V
C514	C515	571-0K72500	Cer.Cap.	0.005 uF + -10% 50V
C516	C517	573-11M8733	Ele.Cap.	330 uF + -20% 63V
C518	C519	573-11M7647	Ele.Cap.	47 uF + -20% 50V
C520	C521	571-0J70220	Cer.Cap.	22 PF + -5% 50V
C522		573-11M7547	Ele.Cap.	4.7 uF + -20% 50V
C523		573-11M7622	Ele.Cap.	22 uF + -20% 50V
C524		573-11M7522	Ele.Cap.	2.2 uF + -20% 50V
C525		573-11M7647	Ele.Cap.	47 uF + -20% 50V
C526		573-11M6647	Ele.Cap.	47 uF + -20% 50V
C527	C528	571-0K73100	Cer.Cap.	0.01 uF + -10% 50V
C529		571-0K73100	Cer.Cap.	0.01 uF + -10% 50V
C531		573-11Z5822	Ele.Cap.	2200 uF + 80-20% 25V
C902		571-0Z72100	Cer.Cap.	0.0001 uF + 80-20% 50V
C904		571-0Z73200	Cer.Cap.	0.02 uF + 80-20% 50V
C905		571-0Z73100	Cer.Cap.	0.01 uF + 80-20% 50V
C906		571-0M72220	Cer.Cap.	0.0022 uF + -20 50V
C907		573-11M7522	Ele.Cap.	2.2 uF + -20% 50V
C908		573-11M7510	Ele.Cap.	1 uF + -20% 50V
C909		571-0Z73200	Cer.Cap.	0.02 uF + 80-20% 50V
C910		573-11M6710	Ele.Cap.	100 uF + -20% 35V
C911		573-11M7447	Ele.Cap.	0.47 uF + -20% 50V
C912		571-0M73470	Cer.Cap.	0.047 uF + -20% 50V
C913		573-11M7522	Ele.Cap.	2.2 uF + -20% 50V
C914		573-51M2847	Ele.Cap.	4700 uF + -20% 6.3V Low Leakage
C915		571-0Z73100	Cer.Cap.	0.01 uF + 80-20 50V
C916		571-1J70180	Cer.Cap.	18 PF + -5% 50V NPO
C917		516-2030S1	Trimer	30 PF
C918		571-0M73470	Cer.Cap.	0.047 uF + -20% 50V
C919		571-0J71100	Cer.Cap.	100 PF + -5% 50V
C920	C921	571-0Z73200	Cer.Cap.	0.02 uF + 80-20% 50V
C922		573-11M7547	Ele.Cap.	4.7 uF + -20% 50V
C923		571-1J70680	Cer.Cap.	68 PF + -5% 50V NPO
C924		571-0Z73100	Cer.Cap.	0.01 uF + 80-20 50V
C601	C603	573-11MA622	Ele.Cap.	22 uF + -20% 100V
C801	C802	573-11M4622	Ele.Cap.	22 uF + -20% 16V
C803	C804	573-11M4622	Ele.Cap.	22 uF + -20% 16V
D101	D102	501-31N60P	Diode	1N60P
D103	D104	501-5SVC321	Diode	SVC321SPA
D105	D106	501-21N4148	Diode	1N4148
D201	D202	501-21N4148	Diode	1N4148
D203	D204	501-21N4148	Diode	1N4148
D301	D302	501-21N4148	Diode	1N4148
D303	D304	501-21N4148	Diode	1N4148
D401	D402	501-21N4148	Diode	1N4148
D403	D404	501-21N4148	Diode	1N4148
D405	D406	501-21N4148	Diode	1N4148
D501	D502	501-11N5401	Diode	1N5401 3A 100V 7225
D503	D504	501-11N5401	Diode	1N5401 3A 100V 7225
D505	D506	501-11N5401	Diode	1N5401 3A 100V
D507	D508	501-11N5401	Diode	1N5401 3A 100V

SYMBOL NO.	PART NO.	DESCRIPTION	REF.
D509	D510	501-11N5401	Diode 1N5401 3A 100V 7225
D511		501-7RS102	Diode 100V 1A
D512		501-21N4148	Diode 1N4148
D513		501-40240-005	Zener 24V 0.5W
D514	D515	501-11N4002	Diode 1N4002 1A
D601	D603	501-21N4148	Diode 1N4148
D702		502-1R2541	LED SLB25YY3F Yellow
D703		502-1R2552	LED TLG218 Green
		502-250321	Display LA30555-11 4 Digits
D801	D802	501-21N4148	Diode 1N4148
D803	D804	501-21N4148	Diode 1N4148
D805	D806	501-40110-005	Zener 11V 0.5W
D901	D902	501-21N4148	Diode 1N4148
D903	D904	501-21N4148	Diode 1N4148
D905	D906	501-21N4148	Diode 1N4148
E401	E402	530-25600-B	Breaker 2.5A
E401	E402	530-35400-B	Breaker 3.5A
E501	E502	549-21851	PTC 1.85A
F501	F502	530-4041B	Fuse 4A/250V
F501	F502	530-4051A	Fuse 4A/125V Semko
F503	F504	530-4041B	Fuse 4A/250V UL/CSA
F503	F504	530-4051A	Fuse 4A/125V Semko
F505	F506	530-1041B	Fuse 1A/250V UL/CSA
F505	F506	530-1051A	Fuse 1A/250V UL/CSA
I101		525-DTSI101	AM IFT
I102		525-DTSI102	FM Coil
I103		525-DTSI103	FM Coil
J534		529-51A01	AC Cord
J534		529-53B01	AC Cord
J534		529-53M01	AC Cord
J534		529-53S01	AC Cord
J933		562-730200	Wire RF
L101		525-DTSL101	AM Coil
L102		525-DTSL102	AM Osc. Coil
L103		524-8022221	Coil 2.2 uH + -20%
L104		524-8560221	Coil 56 uH + -20%
L201	L202	524-8372231	Coil 3.7 mH + -20%
L401	L402	524-108051	Coil 1 uH
P101		527-441103	Jack Antenna 4P
P103		563-1260925	Ribon Connector 250 mm 9P
P106		563-1260314	Ribon Connector 140 mm 3P
P125		563-1260523	Ribon Connector 230 mm 5P
P126		563-1260622	Ribon Connector 220 mm 6P
P201		527-421201	Jack Signal 2P Gold Plated
P301	P302	527-441101	Jack Signal 4P
P303		527-441101	Jack Signal 4P
P304		563-1260823	Ribon Connector 230 mm 8P
P305		563-1260704	Ribon Connector 40 mm 7P
P402		563-1240511	Ribon Connector 110 mm 5P
P501	P502	527-3125U	AC Outlet
P503	P504	538-0520	Fuse Clip
P505	P506	538-0520	Fuse Clip
P507	P508	538-0520	Fuse Clip
P509	P510	538-0520	Fuse Clip
P511	P512	538-0520	Fuse Clip
P513	P514	538-0520Z	Fuse Clip
		527-6002	Bushing Power
PTH		707-121101	Thermistor 110 C PTH487A01BC471TS
Q101	Q102	517-2SC930E	Tr. 2SC930E
Q103		517-2SC930E	Tr. 2SC930E
Q104		503-LA1265	IC. LA1265
Q105		503-LA3401	IC. LA3401
Q106	Q107	517-2SC1815Y	Tr. 2SC1815Y
Q108	Q109	517-2SC1815Y	Tr. 2SC1815Y
Q110		517-2SC1815Y	Tr. 2SC1815Y
Q111		517-2SA1015Y	Tr. 2SA1015Y
Q201	Q202	517-BC550C	Tr. BC550C
Q203	Q204	517-BC550C	Tr. BC550C
Q205	Q206	517-2SA1015Y	Tr. 2SA1015Y
Q207	Q208	517-2SA1015Y	Tr. 2SA1015Y
Q301	Q302	517-BC560C	Tr. BC560C
Q303	Q304	517-2SC1815Y	Tr. 2SC1815Y
Q305	Q306	517-2SC1815Y	Tr. 2SC1815Y
Q307	Q308	517-2SA1015Y	Tr. 2SA1015Y
Q309	Q310	517-2SK363BL	Tr. 2SK363BL
Q401	Q402	517-BC550C	Tr. BC550C
Q403	Q404	517-BC556B	Tr. BC556B



SYMBOL NO.		PART NO.	DESCRIPTION	REF.	
Q405	Q406	517-BC556B	Tr.	BC556B	
Q407	Q408	517-BD139-10	Tr.	BD139-10	
Q409	Q410	517-BD139-10	Tr.	BD139-10	
Q411	Q412	517-2SD669AC	Tr.	2SD669AC	
Q413	Q414	517-2SB649A-C	Tr.	2SB649A-C	
Q415	Q416	517-2N3055	Tr.	2N3055	
Q417	Q418	517-MJ2955	Tr.	MJ2955	
Q501		517-2SA1015Y	Tr.	2SA1015Y	7225
Q502		517-2SC1815Y	Tr.	2SC1815Y	7225
Q503		517-2SA950Y	Tr.	2SA950Y	7225
Q504		517-2SC2120Y	Tr.	2SC2120Y	7225
Q505		517-2SB633D	Tr.	2SB633D	7225
Q506		517-2SD613D	Tr.	2SD613D	7225
Q507		517-2SD669AC	Tr.	2SD669AC	
Q508		517-2SB649A-C	Tr.	2SB649A-C	
Q509		517-2SC1815Y	Tr.	2SC1815Y	
Q510		517-2SA1015Y	Tr.	2SA1015Y	
Q511		517-BD139-10	Tr.	BD139-10	
Q516		517-2SC2240GR	Tr.	2SC2240GR	
Q517		517-2SA1015Y	Tr.	2SA1015Y	
Q701		503-TD6301AP	IC.	TD6301AP	
Q702		517-2SC1815Y	Tr.	2SC1815Y	
Q703		517-2SA1015Y	Tr.	2SA1015Y	
Q902	Q903	517-2SC1815Y	Tr.	2SC1815Y	
Q904		517-2SC1815Y	Tr.	2SC1815Y	
Q906		503-TD6104P	IC.	TD6104P	
Q907	Q908	517-2SC1815Y	Tr.	2SC1815Y	
Q909		517-2SC1815Y	Tr.	2SC1815Y	
Q910		517-2SA1015Y	Tr.	2SA1015Y	
Q911		503-TC9147BP	IC.	TC9147BP	
R101		704-13J1820	Res. Carb.	82 1/4W	+ -5%
R102		704-13J3470	Res. Carb.	4.7K 1/4W	+ -5%
R103		704-13J1820	Res. Carb.	82 1/4W	+ -5%
R104		704-13J3470	Res. Carb.	4.7K 1/4W	+ -5%
R105		704-13J2470	Res. Carb.	470 1/4W	+ -5%
R106	R107	704-13J2390	Res. Carb.	390 1/4W	+ -5%
R108		704-13J2180	Res. Carb.	180 1/4W	+ -5%
R109		704-13J5120	Res. Carb.	120K 1/4W	+ -5%
R110		704-13J5100	Res. Carb.	100K 1/4W	+ -5%
R111		704-13J5180	Res. Carb.	180K 1/4W	+ -5%
R112		704-13J5120	Res. Carb.	120K 1/4W	+ -5%
R113		704-13J6220	Res. Carb.	2.2M 1/4W	+ -5%
R114		704-13J4470	Res. Carb.	47K 1/4W	+ -5%
R115		704-13J3270	Res. Carb.	2.7K 1/4W	+ -5%
R116	R117	508-A103	Res. VR	10K	
R118	R119	704-13J4100	Res. Carb.	10K 1/4W	+ -5%
R120		704-13J3330	Res. Carb.	3.3K 1/4W	+ -5%
R121		704-13J4220	Res. Carb.	22K 1/4W	+ -5%
R122		704-13J1820	Res. Carb.	82 1/4W	+ -5%
R123		704-13J2220	Res. Carb.	220 1/4W	+ -5%
R124		704-13J4120	Res. Carb.	12K 1/4W	+ -5%
R125		704-13J4330	Res. Carb.	33K 1/4W	+ -5%
R126		704-13J3470	Res. Carb.	4.7K 1/4W	+ -5%
R127		508-A224	Res. VR	220K	
R128		704-13J3330	Res. Carb.	3.3K 1/4W	+ -5%
R129	R130	704-13J4820	Res. Carb.	82K 1/4W	+ -5%
R129	R130	704-13J5120	Res. Carb.	120K 1/4W	+ -5%
R131		704-13J4120	Res. Carb.	12K 1/4W	+ -5%
R132		704-13J4150	Res. Carb.	15K 1/4W	+ -5%
R133	R134	704-13J3330	Res. Carb.	3.3K 1/4W	+ -5%
R135	R136	704-13J3470	Res. Carb.	4.7K 1/4W	+ -5%
R137	R138	704-13J2820	Res. Carb.	820 1/4W	+ -5%
R139	R140	704-13J3330	Res. Carb.	3.3K 1/4W	+ -5%
R141	R142	704-13J4390	Res. Carb.	39K 1/4W	+ -5%
R143	R144	704-13J5100	Res. Carb.	100K 1/4W	+ -5%
R145	R146	704-13J2100	Res. Carb.	100 1/4W	+ -5%
R147		704-13J4100	Res. Carb.	10K 1/4W	+ -5%
R148		704-13J3150	Res. Carb.	1.5K 1/4W	+ -5%
R149	R150	704-13J5120	Res. Carb.	120K 1/4W	+ -5%
R151	R152	704-13J1220	Res. Carb.	22 1/4W	+ -5%
R153	R154	704-13J5100	Res. Carb.	100K 1/4W	+ -5%
R155	R156	704-13J3680	Res. Carb.	6.8K 1/4W	+ -5%
R159		704-13J4100	Res. Carb.	10K 1/4W	+ -5%
R201	R202	704-13J5330	Res. Carb.	330K 1/4W	+ -5%
R203	R204	704-13J4560	Res. Carb.	56K 1/4W	+ -5%
R205	R206	704-13J3220	Res. Carb.	2.2K 1/4W	+ -5%
R207	R208	704-13J4100	Res. Carb.	10K 1/4W	+ -5%

A/A1  
B/B1/C/C1

SYMBOL NO.		PART NO.	DESCRIPTION	REF.		
R209	R210	704-13J2680	Res.Carb.	680	1/4W	+ -5%
R211	R212	704-13J4150	Res.Carb.	15K	1/4W	+ -5%
R213	R214	704-13J3390	Res.Carb.	3.9	1/4W	+ -5%
R215	R216	704-13G2200	Res.Carb.	200	1/4W	+ -2%
R217	R218	704-13G5120	Res.Carb.	120K	1/4W	+ -2%
R219	R220	704-13G4120	Res.Carb.	10K	1/4W	+ -2%
R221	R222	704-13G2180	Res.Carb.	180	1/4W	+ -2%
R223	R224	704-13J2150	Res.Carb.	150	1/4W	+ -5%
R225	R226	704-13J3560	Res.Carb.	5.6K	1/4W	+ -5%
R227	R228	704-13J3560	Res.Carb.	5.6K	1/4W	+ -5%
R229	R230	704-13J2470	Res.Carb.	470	1/4W	+ -5%
R231	R232	704-13J2100	Res.Carb.	100	1/4W	+ -5%
R233	R234	704-13J5220	Res.Carb.	220K	1/4W	+ -5%
R235	R236	704-13J2680	Res.Carb.	680	1/4W	+ -5%
R237	R238	704-13J2470	Res.Carb.	470	1/4W	+ -5%
R300		704-13J3100	Res.Carb.	1K	1/4W	+ -5%
R303	R304	704-13J5220	Res.Carb.	220K	1/4W	+ -5%
R305	R306	704-13J4820	Res.Carb.	82K	1/4W	+ -5%
R307	R308	704-13J2390	Res.Carb.	390	1/4W	+ -5%
R309	R310	704-13J3390	Res.Carb.	3.9K	1/4W	+ -5%
R311	R312	704-13J3270	Res.Carb.	2.7K	1/4W	+ -5%
R313	R314	704-13J3680	Res.Carb.	6.8K	1/4W	+ -5%
R315	R316	704-13J3680	Res.Carb.	6.8K	1/4W	+ -5%
R317	R318	704-13J4120	Res.Carb.	12K	1/4W	+ -5%
R319	R310	704-13J1680	Res.Carb.	68	1/4W	+ -5%
R321	R322	704-13J1680	Res.Carb.	68	1/4W	+ -5%
R323	R324	704-13J3100	Res.Carb.	1K	1/4W	+ -5%
R325	R326	704-13J2180	Res.Carb.	180	1/4W	+ -5%
R327	R328	704-13J4150	Res.Carb.	15K	1/4W	+ -5%
R329	R330	704-13J3390	Res.Carb.	3.9K	1/4W	+ -5%
R331	R332	704-13J2680	Res.Carb.	680	1/4W	+ -5%
R333	R334	704-13J2560	Res.Carb.	560	1/4W	+ -5%
R335	R336	704-13J3220	Res.Carb.	2.2K	1/4W	+ -5%
R337	R338	704-13J3100	Res.Carb.	1K	1/4W	+ -5%
R339		507-3203B21-T	Res.VR	20KB	× 2	
R340		507-3103C21	Res.VR	10KC	× 2	
R341		507-3503C21	Res.VR	50KC	× 2	
R342		507-3203W11-T	Res.VR	20KW		
R345	R346	704-13J3100	Res.Carb.	1K	1/4W	+ -5%
R347	R348	704-13J3100	Res.Carb.	1K	1/4W	+ -5%
R349	R350	704-13J3100	Res.Carb.	1K	1/4W	+ -5%
R353	R354	704-13J4100	Res.Carb.	10K	1/4W	+ -5%
R401	R402	704-13J5220	Res.Carb.	220K	1/4W	+ -5%
R405	R406	704-13J2390	Res.Carb.	390	1/4W	+ -5%
R407	R408	704-13J4220	Res.Carb.	22K	1/4W	+ -5%
R409	R410	704-13J4220	Res.Carb.	22K	1/4W	+ -5%
R411	R412	508-A004	Res.SVR.	470		
R415	R416	704-13J2150	Res.Carb.	150	1/4W	+ -5%
R417	R418	704-13J4180	Res.Carb.	18K	1/4W	+ -5%
R419	R420	704-13J2390	Res.Carb.	390	1/4W	+ -5%
R421	R422	704-13J3150	Res.Carb.	1.5K	1/4W	+ -5%
R423	R424	704-13J3220	Res.Carb.	2.2K	1/4W	+ -5%
R425	R426	704-13J2390	Res.Carb.	390	1/4W	+ -5%
R427	R428	704-13J1270	Res.Carb.	27	1/4W	+ -5%
R429	R430	705-15J2470	Res.MOF.	470	1W	+ -5%
R431	R432	704-14J3180	Res.Carb.	1.8K	1/2W	+ -5%
R433	R434	704-13J1470	Res.Carb.	47	1/4W	+ -5%
R435	R436	704-13J2390	Res.Carb.	390	1/4W	+ -5%
R437	R438	705-14J1680	Res.MOF	68	1/2W	+ -5%
R439	R440	705-14J2220	Res.MOF	220	1/2W	+ -5%
R441	R442	705-14J2100	Res.MOF	100	1/2W	+ -5%
R443	R444	508-A003	Res.SVR.	100		
R445	R446	704-13J1390	Res.Carb.	39	1/4W	+ -5%
R447	R448	704-14J3120	Res.Carb.	1.2K	1/2W	+ -5%
R449	R450	704-14J3120	Res.Carb.	1.2K	1/2W	+ -5%
R451	R452	704-13J1330	Res.Carb.	33	1/4W	+ -5%
R453	R454	705-14J2180	Res.MOF	180	1/2W	+ -5%
R455	R456	704-13J0100	Res.Carb.	1	1/4W	+ -5%
R457	R458	705-15J1100	Res.MOF.	10	1W	+ -5%
R459	R460	704-14J2220	Res.Carb.	220	1/2W	+ -5%
R461	R462	704-13J5220	Res.Carb.	220K	1/4W	+ -5%
R463	R464	704-15J0330	Res.Carb.	3.3	1W	+ -5%
R501	R502	705-16J0022	Res.MOF.	0.22	2W	+ -5%
R503	R504	704-13J2270	Res.Carb.	270	1/4W	+ -5%
R505	R506	704-13J3680	Res.Carb.	6.8K	1/4W	+ -5%
R507	R508	704-13J2120	Res.Carb.	120	1/4W	+ -5%
R509	R510	704-13J3680	Res.Carb.	6.8K	1/4W	+ -5%

7225  
7225  
7225  
7225  
7225

SYMBOL NO.	PART NO.	DESCRIPTION	REF.
R511	705-15J1100	Res.MOF	10 1W +-5%
R512	705-16J2100	Res.MOF	100 2W +-5%
R513	R515 704-13J3150	Res.Carb.	1.5K 1/4W +-5%
R514	R516 704-13J3120	Res.Carb.	1.2K 1/4W +-5%
R517	R518 704-13J3120	Res.Carb.	1.2K 1/4W +-5%
R519	704-13J3560	Res.Carb.	5.6K 1/4W +-5%
R520	704-13J4120	Res.Carb.	12K 1/4W +-5%
R521	704-13J2100	Res.Carb.	100 1/4W +-5%
R522	R601 704-13J3120	Res.Carb.	1.2K 1/4W +-5%
R523	704-13J4820	Res.Carb.	82K 1/4W +-5%
R524	704-13J4150	Res.Carb.	15K 1/4W +-5%
R536	704-13J4470	Res.Carb.	47K 1/4W +-5%
R537	704-13J4150	Res.Carb.	15K 1/4W +-5%
R538	704-13J5100	Res.Carb.	100K 1/4W +-5%
R602	704-13J2390	Res.Carb.	390 1/4W +-5%
R603	R604 704-13J5150	Res.Carb.	150K 1/4W +-5%
R605	R606 704-13J7220	Res.Carb.	22M 1/4W +-5%
R701	R702 704-13J2560	Res.Carb.	560 1/4W +-5%
R703	R704 704-13J4150	Res.Carb.	15K 1/4W +-5%
R705	R706 704-13J2680	Res.Carb.	680 1/4W +-5%
R707	R708 704-13J2680	Res.Carb.	680 1/4W +-5%
R709	R700 704-13J2680	Res.Carb.	680 1/4W +-5%
R711	R712 704-13J2680	Res.Carb.	680 1/4W +-5%
R713	R714 704-13J2680	Res.Carb.	680 1/4W +-5%
R715	R716 704-13J2680	Res.Carb.	680 1/4W +-5%
R717	R718 704-13J2680	Res.Carb.	680 1/4W +-5%
R719	R720 704-13J2680	Res.Carb.	680 1/4W +-5%
R721	R722 704-13J2680	Res.Carb.	680 1/4W +-5%
R723	R724 704-13J2680	Res.Carb.	680 1/4W +-5%
R725	R726 704-13J2680	Res.Carb.	680 1/4W +-5%
R727	R728 704-13J2680	Res.Carb.	680 1/4W +-5%
R729	R730 704-13J2680	Res.Carb.	680 1/4W +-5%
R731	R732 704-13J2680	Res.Carb.	680 1/4W +-5%
R733	R734 704-13J2680	Res.Carb.	680 1/4W +-5%
R735	704-13J2680	Res.Carb.	680 1/4W +-5%
R801	R802 704-13J3180	Res.Carb.	1.8K 1/4W +-5%
R803	R804 704-13J3180	Res.Carb.	1.8K 1/4W +-5%
R805	R806 704-13J3100	Res.Carb.	1K 1/4W +-5%
R807	R808 704-13J3100	Res.Carb.	1K 1/4W +-5%
R809	R810 704-13J4180	Res.Carb.	18K 1/4W +-5%
R811	R812 704-13J4180	Res.Carb.	18K 1/4W +-5%
R904	704-13J4150	Res.Carb.	15K 1/4W +-5%
R905	704-13J3150	Res.Carb.	1.5K 1/4W +-5%
R906	704-13J3470	Res.Carb.	4.7K 1/4W +-5%
R907	704-13J4820	Res.Carb.	82K 1/4W +-5%
R908	704-13J4150	Res.Carb.	15K 1/4W +-5%
R909	704-13J2470	Res.Carb.	470 1/4W +-5%
R912	704-13J2100	Res.Carb.	100 1/4W +-5%
R914	704-13J4560	Res.Carb.	56K 1/4W +-5%
R915	704-13J4270	Res.Carb.	27K 1/4W +-5%
R916	704-13J3470	Res.Carb.	4.7K 1/4W +-5%
R917	704-13J4100	Res.Carb.	10K 1/4W +-5%
R918	704-13J2100	Res.Carb.	100 1/4W +-5%
R919	704-13J3820	Res.Carb.	8.2K 1/4W +-5%
R920	704-13J5150	Res.Carb.	150K 1/4W +-5%
R921	704-13J4100	Res.Carb.	10K 1/4W +-5%
R922	R923 704-13J5100	Res.Carb.	100K 1/4W +-5%
R924	704-13J4560	Res.Carb.	56K 1/4W +-5%
R925	704-13J4150	Res.Carb.	15K 1/4W +-5%
R926	704-13J5100	Res.Carb.	100K 1/4W +-5%
R927	R928 704-13J4150	Res.Carb.	15K 1/4W +-5%
R929	704-13J5100	Res.Carb.	100K 1/4W +-5%
R930	704-13J3100	Res.Carb.	1K 1/4W +-5%
S201	526-3102	SW Push	4P
S301	526-3103	SW Push	2P
S401	526-3108	SW Push	2P
S501	526-3110-1	SW Power	
S502	526-3105	SW Slide	2P2T
S801	526-52205	SW Slide	2P2T
S901	S902 526-81101	SW Tact Sw.	1P1T KPT-1105
S903	S904 526-81101	SW Tact Sw.	1P1T KPT-1105
S905	S906 526-81101	SW Tact Sw.	1P1T KPT-1105
S907	S908 526-81101	SW Tact Sw.	1P1T KPT-1105
S909	526-32204-L	SW Push	2P2T W/Lock
T	521-167AMV501	Power Transformer	
U101	540-0411	Electronic Tuner	FE407-A12
U101	540-0412	Electronic Tuner	FE407-G23

A/A1/B/B1/C  
FTZ (C1)

SYMBOL NO.	PART NO.	DESCRIPTION		REF.
W401	527-4020	Jack Headphone		
X101	537-1014K	Filter 450KHz	BFU450C	
X102	537-3456K	Resonator 456KHz	CSB456F11	
X901	522-072M21	Crystal	7.2MHz	
Z101	537-1102M1	Filter	10.7MHz	+ -20 ppm
Z102	537-1102M2	Filter	10.7MHz	SFE10.7MS2LHA
Z101 Z102	537-1102M3	Filter	10.7MHz	SFE10.7MS3GHA
Z103	537-1013K	Filter	450KHz	SFE10.7ML-A
Z104	525-DTSZ104	FTZ Coil		SFZ450G
Z105 Z106	525-DTSF19K	Filter	19KHz	
	531-70201058-1	Main Board		
	531-70204047	Tuner Board		
	531-70205030	Power Supply Board		
	531-70207053	LED Display Board		
	531-70209017	Headphone Board		
	531-7020B005	Volume Board		
	531-7020F002	Tuning Control Board		
	531-7020U001	Terminal Board		
	531-7020X001	Binding Post Board		
	531-2201	Ext.Pre-Amp. Board		

# EXPLODED VIEW

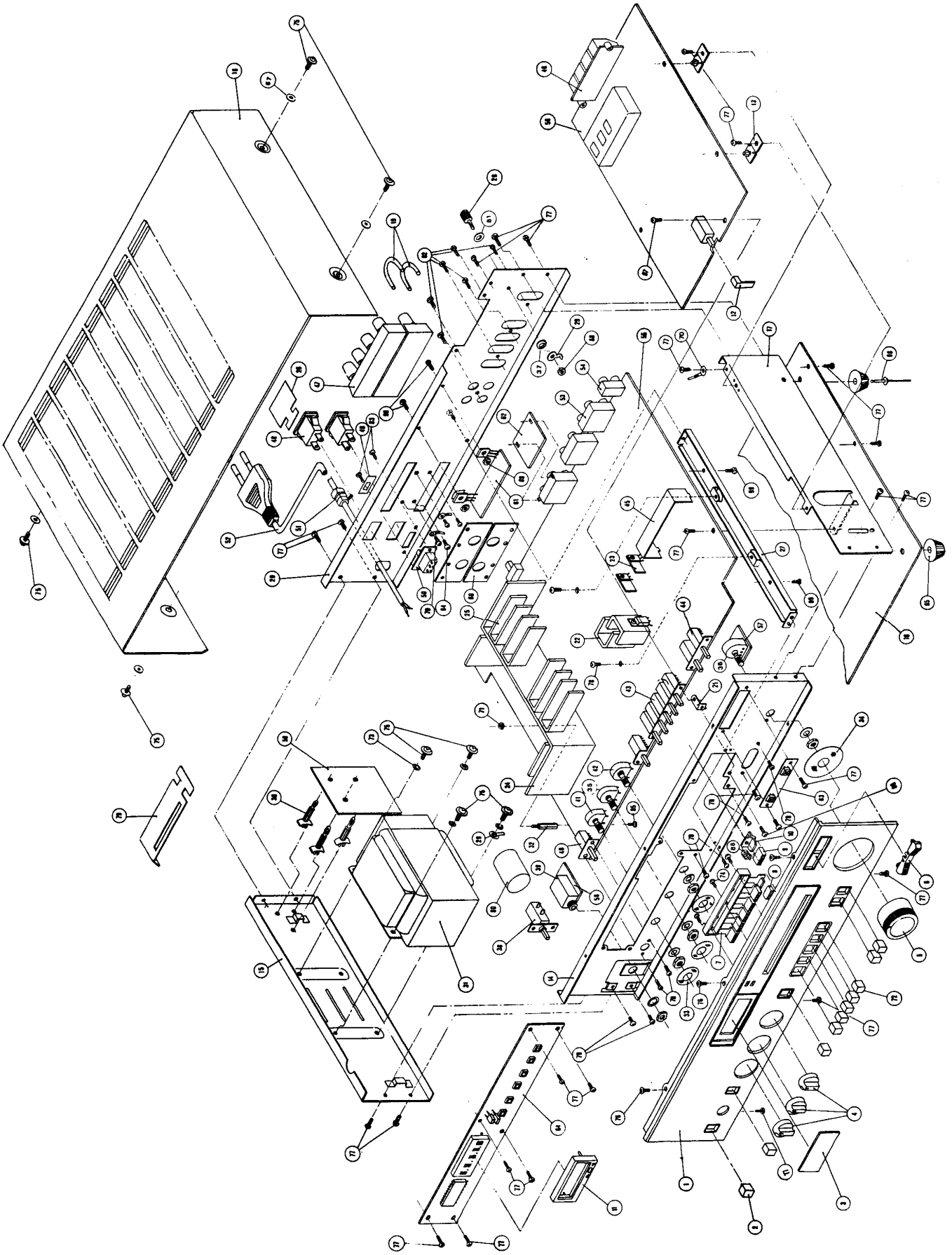

## 7020I/7225PE Exploded View P/L

ITEM	PART NO.	DESCRIPTION	QTY
1	055-141A	Panel-Front	1
2	073-1625	Button-Push (Green)	1
3	071-2900	Lens-LED Window	1
4	081-1110	Knob-Control	1
5	081-1100	Knob-Volume	3
6	073-1630	Button-Rocker	1
7	073-1640	Button-Chassis	1
8	073-1611	Button-Enter	1
9	073-1610	Button-Search	1
10	080-2010	Connector-Switch	1
11	080-2020	Holder-LED	1
12	096-1740	Lever-Connector	1
13	080-2030	Hinge	1
14	095-7150	Plate-Front	2
15	095-7070	Plate-Left	1
16	049-0700	Cover-Bottom	1
17	095-7140	Plate-Right	1
18	049-0694	Cover-Top	1
19	085-1360	Bar-Shorting	1
20	095-710R	Panel-Back (AH Version, 7020I)	2
	095-710O	Panel-Back (B Version, 7020I)	1
	095-710N	Panel-Back (C Version, 7020I)	1
	095-710S	Panel-Back (AH Version, 7225PE)	1
	095-710Q	Panel-Back (B Version, 7225PE)	1
	095-710P	Panel-Back (C Version, 7225PE)	1
21	078-8130	Bkt-Tuner PCB	1
22	083-0790	Heat Sink-Power Envelope (7225PE)	1
23	083-0720	Heat Sink (S)	2
24	083-0730	Heat-Sink	2
25	083-0780	Heat Sink Fin (7225PE)	1
26	095-7120	Plate-AC Socket Cover PVC (AH Version Only)	4
27	078-8120	Bkt-Middle	1
28	085-1350	Thumb Screw Stud	1
29	027-6003	Soldering Tag	1
30	080-2310	Supporter-PCB	2
31	531-167AMV501	Power Transformer	3
32	085-1400	Post-PCB	1
33	082-4500	Felt-Control Knob	3
34	082-4490	Felt-Volume Knob	3
35	507-3103C21	Res. VR-10KC x 2	1
36	507-3203B21-T	Res. VR-20KB x 2	1
37	094-0760	Washer-External Tooth	1
38	526-32204-L	Switch-Power	1
39	527-4020	Jack-Headphone	1
40	526-3108	Switch-Speaker	1
41	507-3503C21	Res. VR-50KC x 2	1
42	507-3203W11-T	Res. VR-20KW	1
43	526-3102	Switch-Function	1
44	526-3103	Switch-Mono/Loudness	1
45	095-7180	Plate-Shield	1
46	527-441103	Jack-Antenna	1
47	099-0850	Jack-Speaker	1
48	527-3125U	Outlet-AC (AH Version Only)	2
49	095-7110	Plate-Switch	1
50	526-52205	Switch-Impedance	1
51	527-6002	Bushing-AC Cord	1
52	529-51A01	AC Cord UL/CSA (AH)	1
	529-53B01	AC Cord BS (B)	1
	529-53M01	AC Cord VDE/EMKO (C,C1)	1
	529-53S01	AC Cord SAA (B1)	1
53	529-441101	Jack-4P	1
54	527-421201	Jack-2P	3
55	531-70201058-1	PCB-Main	1
56	531-70204047	PCB-Tuner	1
57	531-7020B005	PCB-Volume	1
58	531-70209017	PCB-Headphone	1
59	531-7020U001	PCB-Terminal	1
60	531-7020X001	PCB-Spk. Binding Post	2

ITEM	PART NO.	DESCRIPTION	QTY
61	531-70205030	PCB-Power Supply	
62	531-2201	PCB-Ext. Pre-Amp.	1
63	531-7020F002	PCB-Tuning Control	1
64	531-70207053	PCB-LED Display	1
65	082-4510	Rubber Foot	1
66	099-1100	Rivet	4
67	094-0810	Washer-PVC	4
68	048-0620	Nut-3.5mm	4
69	048-0030	Nut-3mm	1
70	027-5000	Soldering Tag	14
71	048-0060	Nut-2.6mm	3
72	073-1620	Button-Push (Black)	1
73	094-0750	Washer Spring	9
74	093-3006BH	Machine Screw M3 x 0.5 x 6BH	4
75	093-4006WHB(H)	Machine Screw M4 x 0.7P x 6WHB	3
76	093-3008KTB(H)	Self-Tapping 3 x 8KTB	8
77	093-3006BTBB(H)	Self-Tapping Screw 3 x 6BTB	3
78	093-3008BH	Machine Screw M3 x 0.5P x 8BH	29
79	095-7170	Plate-Terminal PCB Cover	11
80	099-0760	UL Heat Shrinkable Tube	1
81	094-0740	Washer-Metal	1
82	093-3008BTBB	Self-Tapping Screw 3 x 8BTBB	1
83	093-3008BHB	Machine Screw M3 x 0.5P x 8BHB	6
84	093-3006BTB	Self-Tapping Screw 3 x 6BTB	3
85	095-2606BHB	Machine Screw M2.6 x 0.45P x 6BHB	10
86	086-0970	Spring-Push	1
87	093-3006BH	Machine Screw M3 x 0.5P x 6BH	1
88	093-3006BH	Machine Screw M3 x 0.5P x 6BH	1
89	093-3006BHB	Machine Screw M3 x 0.5P x 6BHB	8
90	093-3010RHB	Machine Screw M3 x 0.5P x 10RHB	2

**PACKING DIAGRAM**

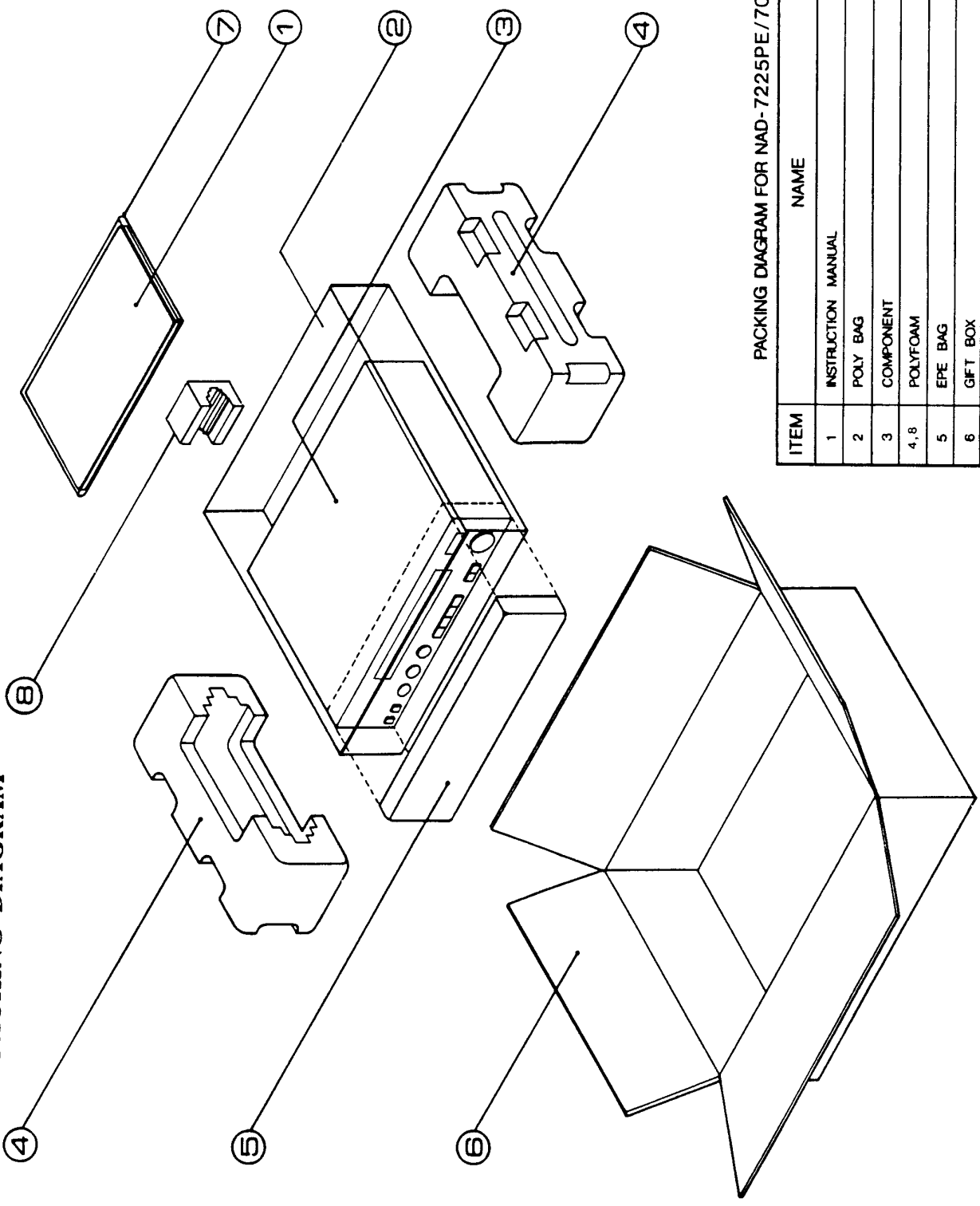

**PACKING DIAGRAM FOR NAD-7225PE/7020i**

ITEM	NAME	QTY
1	INSTRUCTION MANUAL	1
2	POLY BAG	1
3	COMPONENT	1
4,8	POLYFOAM	2,1
5	EPE BAG	1
6	GFT BOX	1
7	POLY BAG	1