

NAD

**SERVICE
MANUAL**

STARTING SERIAL NUMBER A 7401100001

7240
RECEIVER

PAGE	CONTENTS
3	REAR/FRONT PANEL LAYOUT
4	SPECIFICATIONS
5-8	ALIGNMENT METHOD
9	FM ALIGNMENT HOOKUP
10	TUNER ALIGNMENT POINTS
11-12	AMPLIFIER PCB LAYOUT
13-14	AMPLIFIER SCHEMATIC
15-16	TUNER PCB LAYOUT
17-18	TUNER SCHEMATIC
19	TRANSFORMER WIRING (MULTI-VOLTAGE)
19-20	AMPLIFIER PCB WIRING DIAGRAM
21-22	TUNER PCB WIRING DIAGRAM
23	AMPLIFIER PCB PARTS LOCATION
24	TUNER PCB PARTS LOCATION
25	DISPLAY PCB SCHEMATIC, LAYOUT, PARTS LOCATION
26-31	ELECTRICAL PARTS LIST
32-33	EXPLODED VIEW
34-36	EXPLODED PARTS LIST
37	PACKING DIAGRAM

SERVICE SAFETY PRECAUTIONS (UL)

1. Use exact replacement parts for critical locations, marked "⚠".
2. Return lead dress to original position, and re-install protective covers.
3. Before returning to customer, test for shock hazard; use either method A or B:
 - A. Leakage test, "cold":
 1. Unplug AC cord; turn power switch ON.
 2. Connect one lead of High Voltage Insulation Tester to both prongs of AC plug.
 3. Touch other lead to all exposed metal parts.
 4. Impedance measurement must be 0.3 - 5.0 Megohms.
 - B. Leakage test, "live":
 1. Plug unit directly into AC outlet; do not use isolation transformer.
 2. Connect one lead of Leakage Current Tester to earth ground.
 3. Touch other lead to all exposed metal parts.
 4. Leakage measurement must be less than 0.5 milliamps.

REAR PANEL

1. AC Line Cord.
2. AC Outlets.
3. Speakers A.
4. Speakers B.
5. Antenna Terminals.
6. AM Rod Antenna.
7. Phono Input.
8. CD Input.
9. Video Input.
10. Tape Input/Output.
11. Preamp Out, Main In.
12. Soft Clipping.
13. Speaker Impedance.

LE PANNEAU ARRIERE

1. Cordon d'alimentation.
2. Prises CA.
3. Enceintes A.
4. Enceintes B.
5. Bornes d'antenne.
6. Antenne AM.
7. Masse phonolecteur.
8. Entrée phono.
9. Entrée lecteur de disque compact.
10. Entrée vidéo.
11. Entrée/Sortie magnétophone.
12. Sortie de préamplification.
13. Ecrêtage en douceur.
14. Impédance.

RÜCKSEITE

1. Netzkabel.
2. Sekundär-Steckdosen.
3. Anschlüsse für Lautsprechergruppe A.
4. Anschlüsse für Lautsprechergruppe B.
5. Antennen-Auschlüsse.
6. Mittelwellen (AM)-Ferritantenne.
7. Masseanschluss für Plattenspieler.
8. Plattenspieler-Eingang.
9. CD-Eingang.
10. Video.
11. Tonbandgerät-Eingang/Ausgang.
12. Vorverstärker-Ausgang/Endverstärker-Eingang.
13. Impulsbegrenzungs-Schalter.
14. Lautsprecherimpedanz-Schalter.

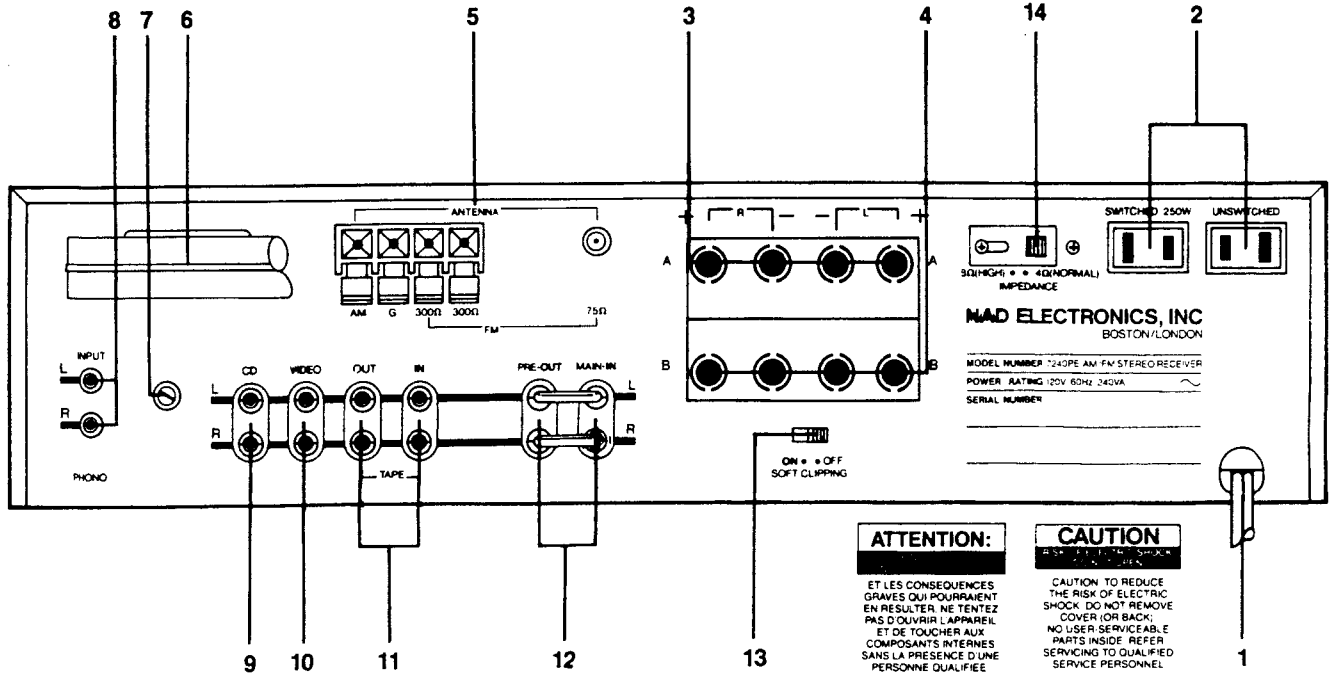

FRONT PANEL

1. Power.
2. Phones.
3. Speaker Selector.
4. Bass.
5. Treble.
6. Bass EQ.
7. Infrasonic Filter Off.
8. Mono.
9. FM NR Off.
10. Tape Monitor.
11. Input Selector.
12. Low Level.
13. Loudness/Balance.
14. Volume/Balance.
15. Tuning Display.
16. Status Indicators.
17. Tuning Pre-sets.
18. Memory Enter.
19. AM/FM.
20. Up/Down Tuning.
21. Search Mode (FM only).

LE PANNEAU AVANT

1. Alimentation.
2. Casque d'écoute.
3. Sélecteur d'enceintes.
4. Graves.
5. Aigus.
6. Bass Eq.
7. Filtre infrasonique.
8. Mono.
9. FM NR Off.
10. Commutateur de surveillance de bande.
11. Sélecteur d'entrée.
12. - Low Level -
13. Commutateur de contour sonore.
14. Volume/Equilibrage.
15. Affichage de la fréquence d'accord.
16. Témoin.
17. Touches de présélection.
18. Touche de mémoire.
19. FM/AM.
20. Syntonisation électronique.
21. Syntonisation automatique.

FRONTSEITE

1. Netzschalter.
2. Kopfhörer-Anschluß.
3. Lautsprecher-Wahlschalter.
4. Baßsteller.
5. Höhensteller.
6. Baß Equalizer-Schalter.
7. Schalter für Infrarot-Filter.
8. Mono/Stereo-Schalter.
9. Stereo-Rauschminderung.
10. Vor/Über Band-Schalter.
11. Eingangs-Wahlschalter.
12. Schalter für Lautstärkeabsenkung.
13. Gehörichige/Lautstärke-Einstellung.
14. Lautstärke/Balance-Seliler.
15. Abstimmanzeige.
16. Anzeigen für Betriebszustände.
17. Stationstasten.
18. Eingabebereitschaft für Stationstastenspeil.
19. Wellenbereichsschalter für UKW/Mittelwell.
20. Wippe zur Frequenzenstellung.
21. Suchlauf, nur UKW.

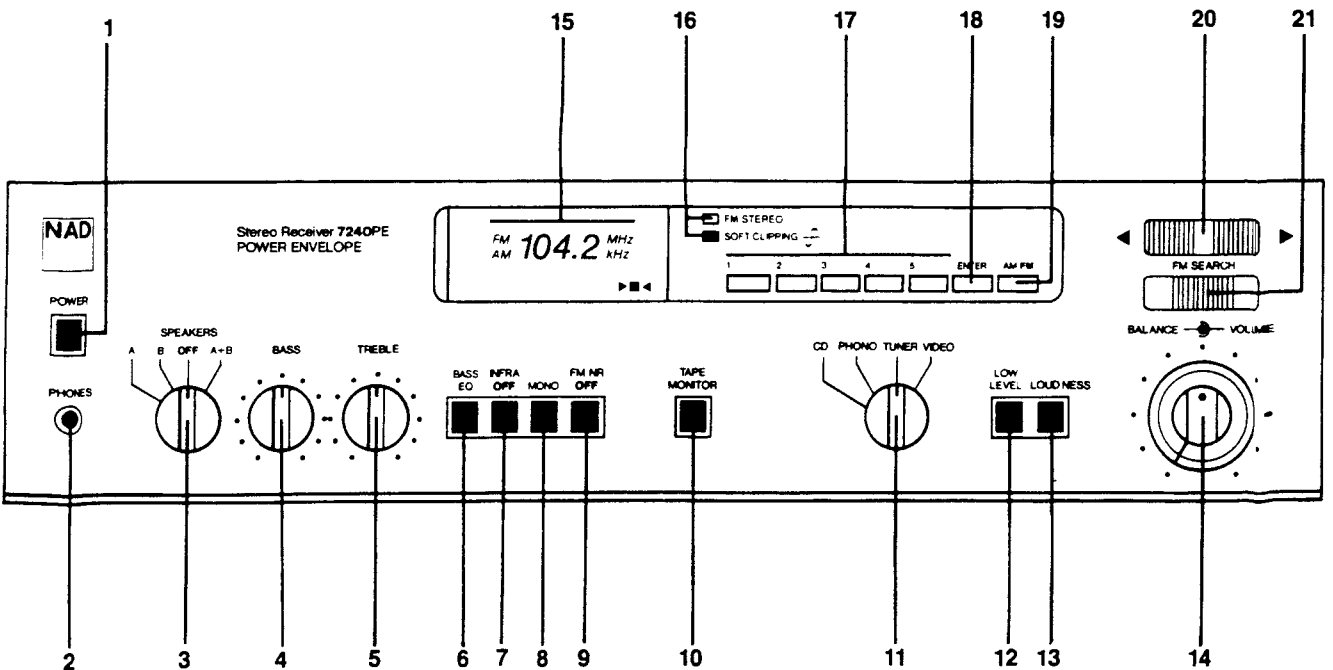

Specifications

NAD 7240PE Stereo Receiver

Note: Specifications are measured in accordance with EIA Standard RS-490 (IHF A-202) for amplifiers and ANSI-IEEE Standard 185 (1975), i. e. IHF T-202, for tuners. Tuner sensitivity is measured via 75-ohm coaxial input and converted to equivalent 300-ohm values. Amplifier measurements referred to 8 ohms are taken with the Speaker Impedance selector set to 8 ohm (High). Measurements for 4 and 2 ohms are taken with Impedance selector at 4 ohm (Normal).

Power Amplifier Section

CONTINUOUS AVERAGE POWER

OUTPUT AT 8 OHMS (minimum RMS power per channel, both channels driven, with no more than the rated distortion)

Rated distortion (THD) 20Hz-20kHz 0.03%

Clipping power, 1kHz (maximum continuous power per channel) 50W

Dynamic Headroom at 8 ohms +6dB

Dynamic power (maximum) 8 ohms 160W

short-term power per channel) 4 ohms 200W

2 ohms 250W

Damping factor >50

Slew factor >50

Slew rate 15V/μsec

T.H.D. and SMPTE.I.M. distortion from 250 mW to rated output <0.03%

IHF.I.M. (CCIF IM) and T.I.M. distortion at rated output <0.03%

Input Impedance 22kohm

Input sensitivity for 1 Watt/40Watts out 160mV/1.0V

Power amp gain 25dB (18X)

Preamplifier Section

Phono Input

Input Impedance R=47kohm, C=100pF

Input Sensitivity (1kHz) 0.55mV for 1 Watt out

3.5mV for 40 Watts out

Signal-to-Noise Ratio with 76dB re 5mV

cartridge connected, A-weighted

Input Overload at 20 Hz/1kHz/20kHz 20/180/1500mV

RIAA Accuracy ±0.5dB

High-Level Inputs (CD, Video, Tape)

Input Impedance R=15kohm, C=100pF

Input Sensitivity 26mV for 1W out

160mV for 40W out

Signal-to-Noise ratio, A-weighted 86dB re 1W out

102dB re 40W out

Input Overload >10V

Frequency Response 20Hz-20kHz ±0.5dB

Outputs

Preamp output impedance 600ohm

Tape output impedance Source Z+1000ohm

Controls

Treble ±7dB at 10kHz

Bass ±10dB at 50Hz

Bass Equalization +3dB at 70Hz

+6dB at 40Hz

Infrasonic Filter -3dB at 12Hz

12dB/octave

Low Level (audio muting) -20dB

FM Tuner Section

Input sensitivity

Mono, -30 dB THD+N 10.3dBf (1.8uV/300ohm,

or 0.9uV into 7.5ohm)

Mono, 50 dB S/N 4.2dBf (2.8uV/300ohm)

Stereo, 50 dB S/N 29dBf (15uV), FM NR on

36dBf (35uV), FM NR off

40dBf (55uV), FM NR on

46dBf (110uV), FM NR off

Stereo 60 dB S/N <1.5dB

Capture ratio (at 45 and 65 dBf)

AM rejection (at 65 and 85dBf) >60dB

Selectivity 65dB

Image rejection 70dB

R.F. intermodulation 65dB

I.F. rejection 90dB

SCA rejection 70dB

Subcarrier suppression (19&38kHz) 60dB

THD at 100% modulation Mono, 1kHz 0.09%

100Hz-6kHz 0.2%

Stereo, 1kHz 0.09%

100Hz-6kHz 0.3%

Signal-to-noise ratio Mono >80dB

HF weighted, 65dBf Stereo >75dB

Frequency response, 30Hz-15kHz +0.5dB

Stereo separation 1kHz 50dB

(FM NR off) 30Hz-10kHz 40dB

AM Tuner Section

Usable sensitivity 300uV/meter

THD 0.5%

Selectivity 35dB

Image rejection 50dB

I.F. rejection 35dB

S/N ratio (30% mod., 50mV input) 45dB

Physical Specifications

Width x Height x Depth 42 x 10.8 x 38 cm

16.5 x 42.5 x 15 in

Net Weight 7.48kg (16.5lbs)

Shipping Weight 8.95kg (19.7lbs)

Power Consumption 50/60Hz at 110, 120,

220, or 240 VAC

200W

Specifications are those in effect at the time of printing. NAD reserves the right to change specifications or designs at any time without notice.

ALIGNMENT METHOD

MAIN AMPLIFIER ALIGNMENT

IMPORTANT NOTES:

- 1) Before adjusting, remove input signal and load, and set Speaker Impedance switch to 8 ohms. (Reset to 4 ohms when finished.)
- 2) These adjustments are always necessary after repair to main amplifier.
- 3) After repair, it is recommended to use current limiter (40-80W lightbulb) in series with AC mains line, for initial turn-on.

A. CENTER VOLTAGE ADJUSTMENT

1. Connect DVM across L channel (R channel) output terminals.
2. Turn on, and adjust VR-401 (VR-402) for reading of $0V \pm 30$ mVDC.

B. IDLE CURRENT ADJUSTMENT

1. Remove solder short across R-471 and R-472.
2. Connect DVM across R-471.
3. Turn on and adjust VR-403 for reading of 28 mV ± 2 mVDC.
4. Repeat, using R-472, adjust VR-404.

C. FINAL ADJUSTMENT

1. Leave power on minimum 5 minutes.
2. Repeat center voltage and idle current adjustments.
3. When finished, replace solder short across R-471 and R-472.

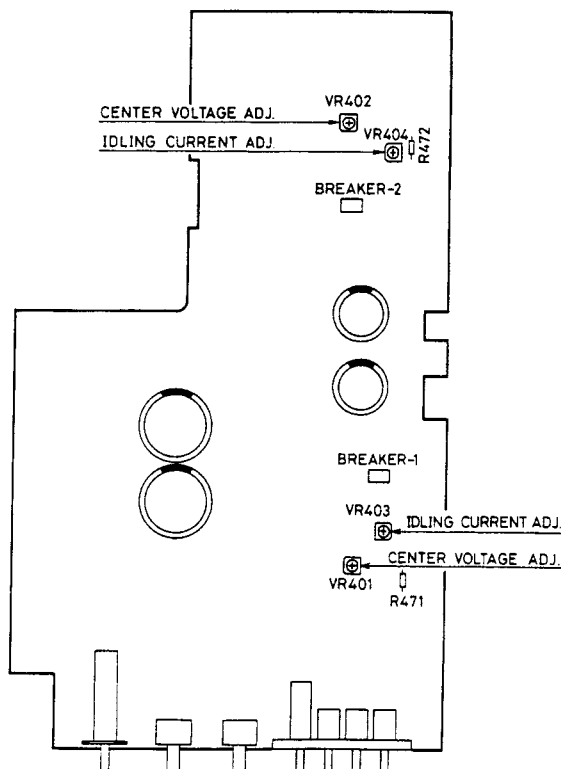

AMPLIFIER ALIGNMENT POINT

FM ALIGNMENT

NECESSARY INSTRUMENTATION:

- Stereo Modulator (less than 0.05% THD, more than 50dB Sep.)
- FM Generator (less than 0.05% THD)
- 300 or 75 ohm Dummy Antenna (if needed by generator)
- Audio Oscillator (not necessary if FM Generator has built-in sweep, e.g., SOUND TECHNOLOGY ST 1000A or ST 1020A)
- 2 AC VTVM's (or one with a Left/Right switch)
- THD Analyzer (resolution less than 0.1%)
- Oscilloscope (5mV or better sensitivity, X-Y capability)
- Frequency Counter
- DMM or DVM
- Diode Detector Probe
- Ferrite/Brass inductor test probe

IMPORTANT NOTES

- 1) RF levels are at 300 ohm antenna input. If using 75 ohm input, divide figures by 2.
- 2) Before aligning, select FM and switch off MONO (out) and FM NR (in).
- 3) If FM Generator is not synthesizer-type, be sure to check its frequency with Frequency Counter when adjusting detector and stereo decoder circuits.
- 4) Hum in measurements may be caused by ground loop via antenna cable; if so, use isolation balun, or isolate antenna input with small capacitors (470~1000pf).
- 5) To adjust front-end coils, bend gently with wooden or plastic tool (non-interactive).
- 6) ENTER the following frequencies: 87.50, 90.00, 98.00, 105.00, 108.00

A. LOCAL OSCILLATOR FREQUENCY

1. Connect Frequency Counter between front-end pin 8 (front-most) and Ground.
2. Tune to 90 MHz (No RF input needed).
3. Adjust VC-2 so that reading is $100.700\text{MHz} \pm 2\text{kHz}$.
4. Remove counter.

B. TUNING VOLTAGE

1. Connect DVM between R-96 (Front Lead) and Ground.
2. Tune to 108.00MHz, and adjust L-702 if reading is not $20.5\text{V} \pm 0.5\text{V}$.
3. Tune to 87.50MHz, and check that reading is $3.0\text{V} \pm 0.5\text{V}$.
4. Repeat 2,3 until within tolerance.
5. Remove DVM

C. TRACKING

1. Connect FM Generator to antenna input (modulate $\pm 150\text{kHz}$ sweep) (300 kHz total) and Detector Probe to Pin 1 of Detector IC-3 (ground to front-end shield).
2. Adjust vertical sensitivity of Oscilloscope to maximum, and set to X-Y mode. (X input is sweep signal, Y is detector probe).
3. Tune to 105MHz and adjust generator so that curve appears on Oscilloscope, and covers approximately 1/2 of display.
4. Check L702, L704, L705 with ferrite/brass probe, adjust only if probe causes curve height to increase more than 10%. If necessary, reduce generator output to keep entire curve on display.
5. Tune to 90MHz and adjust Generator so that curve appears on Oscilloscope.
6. Check L702, L704, L705 again; if necessary, distribute any error between both frequencies.

Note: 105MHz curve is typically slightly higher than 90MHz.

D. IF ADJUSTMENTS

1. Tune to approximately 98MHz (must be an unoccupied frequency), and adjust FM Generator to display curve on the oscilloscope.
2. Adjust L709 for maximum and symmetrical curve using as little RF input as possible.
3. Remove detector probe.

E. DETECTOR ALIGNMENT

1. Connect Tape Output to Distortion Analyzer and Oscilloscope.
2. Connect DVM between TP-1(-) and TP-2 (+).
3. Tune to 98MHz and feed 1000uV from FM Generator (Modulate 1kHz 100%, Mono).
4. Adjust IFT-1B (secondary) (front) for lowest THD. (Spec, <0.1%)
5. Adjust IFT-1A (primary) (rear) for $0V \pm 50mV$ reading on DMM.
6. Repeat 4,5 until no further improvement.

F. MPX VCO FREQUENCY (Use either method A or B)

METHOD A

1. Connect Frequency Counter between pin 11 of MPX IC-7 and Ground.
2. Tune to 98MHz and feed 1000 μV from FM Generator (no modulation, no pilot).
3. Adjust VR-3 for reading of $19.000 \text{ kHz} \pm 100 \text{ Hz}$.
4. Remove Frequency Counter.

METHOD B

1. Connect DVM across C-80.
2. Tune to 98MHz and feed 1000 μV from FM Generator (modulate 1 kHz 100% L+R).
3. Adjust VR-3 for Stereo LED off, and read voltage at C-80.
4. Adjust VR-3 for Stereo LED on, and same reading $\pm 0.5 \text{ mV}$.
5. Remove DVM.

G. TUNING LED OFF

1. Tune to 98MHz and feed 0 μV (no RF output) from FM Generator.
2. Adjust VR-7 from full CCW so that Tuning LED just turns off fully.

H. SEARCH STOP, STEREO LED ON

1. Connect DVM to R-56 (rear lead) and ground.
2. Tune to 98MHz and feed 10 μV from FM Generator.
3. Adjust VR-1 from full CW so that DVM reading just goes from 0V to 4V (approx) at $10 \mu V \pm 2\mu V$.
4. Adjust VR-2 from full CW so that stereo LED just turns on at $10 \mu V \pm 1.5 \mu V$.
NOTE: Switching to mono is at lower level, typically $7\mu V$.
5. Remove DVM.

I. BALANCE

1. Tune to 98MHz and feed 1000 μV from FM Generator (modulate 1 kHz 100% L + R).
2. Measure output level at Tape Out R channel.
3. Adjust VR-4 for same output level $\pm 20 \text{ mV}$ at Tape Out L channel.

J. STEREO DISTORTION & SEPARATION; FILTERS

1. Tune to 98MHz and feed 1000uV from FM Generator. (Modulate 1kHz, 100% L only.)
2. Adjust L-709 just slightly so that distortion on left channel becomes minimum. (Spec, < 0.1%.)
3. Modulate L only. Adjust VR-5 for minimum output on right channel.
4. Next, modulate R only and adjust VR-5 for minimum output on left channel.
If necessary, readjust VR-5 so that readings become same on both channels. (Spec, < -40dB.)
5. Cancel the stereo modulation and leave pilot tone.
6. Adjust LPF-1 (LPF-2) (rear slug) for minimum subcarrier output on left(right) channel. (Spec, < -60dB.)

K. FM NR

1. Tune to 98MHz and feed 1000 μ V from FM Generator (modulate 1 kHz 100% L + R). Check that FM NR is off (in).
2. Set reference for S/N measurement.
3. Cancel stereo modulation and leave pilot tone.
4. Reduce FM Generator output so that S/N Ratio is 50 dB (approx 35 μ V).
5. Switch FM NR on, and adjust VR6 so that S/N is improved by 6 dB.

AM ALIGNMENT

A. TUNING VOLTAGE

1. Connect DVM between R-96 (front lead) and Ground.
2. Tune to 1600(1602)kHz. Enter into memory. Adjust VC-3 for reading of $7.5V \pm 0.5 V$.
3. Tune to 520(522)kHz. Enter into memory. Adjust L-3 for reading of $1.0V \pm 0.1 V$.
4. Repeat 2,3 until within tolerance.
5. Remove DVM.

B. ANTENNA, IF

1. Swing antenna away from chassis.
2. Connect DVM to pin 15, AM IC-6, and Ground.
3. Tune to a station of moderate strength near 1400kHz. Enter into memory. Adjust VC-1 for maximum reading on meter.
4. Adjust IFT-2, IFT-3 for maximum reading on meter.
5. Tune to a station of moderate strength near 600kHz. Enter into memory. Adjust L-2 (AM Antenna) for maximum reading on meter.
6. Repeat 3,5 until no further improvement.
7. Remove DVM.

SUGGESTED INSTRUMENTATION HOOKUP- FM ALIGNMENT

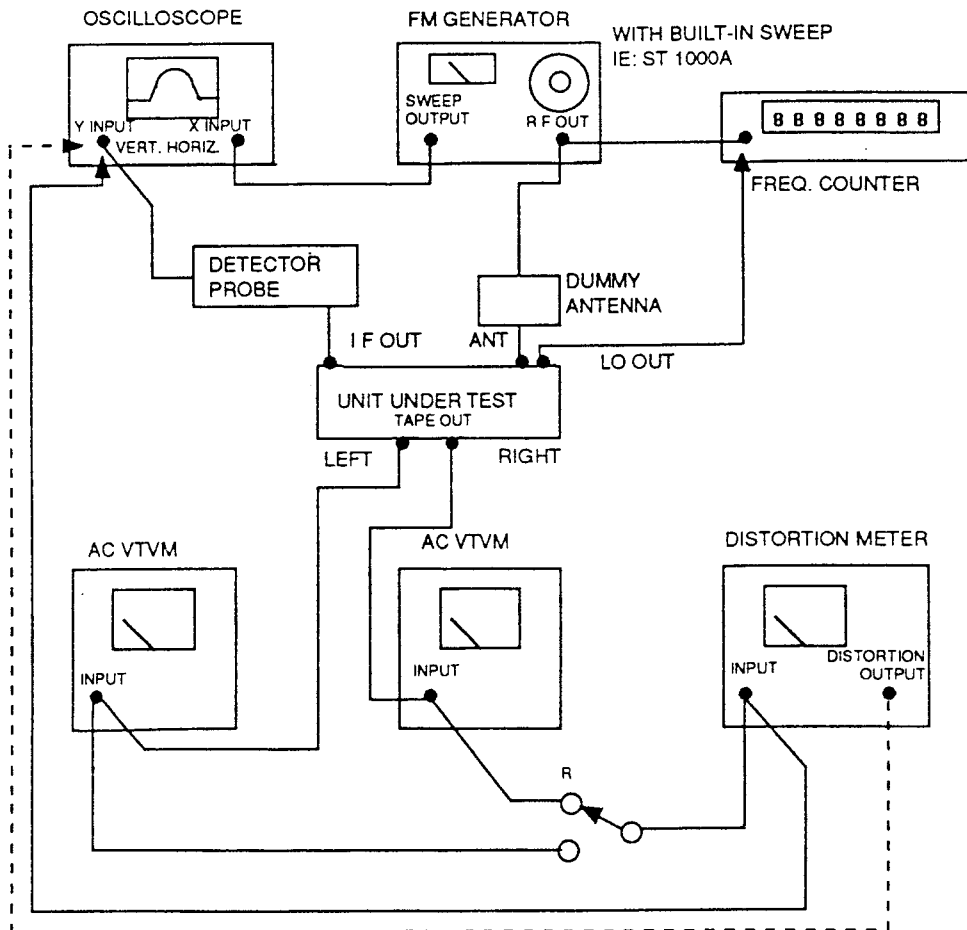
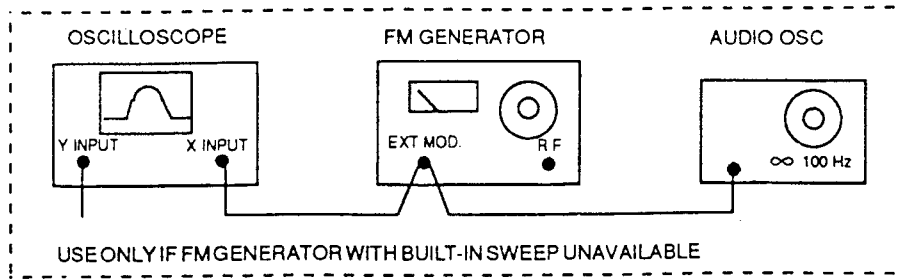

DETECTOR PROBE

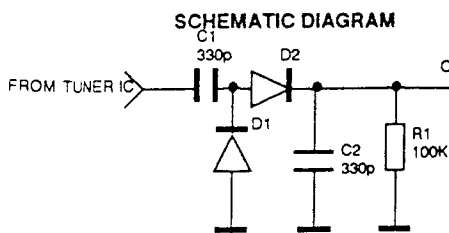

PICTORIAL DIAGRAM

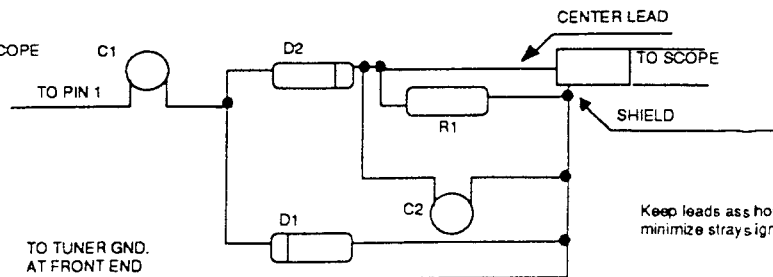

Keep leads as short as possible, to minimize stray signal pickup.

Diodes should be point-contact germanium; some types commonly available are:

OA80
OA61
AA119
1N60
1N34
1N22

INDUCTOR TEST PROBE

THIN BRASS,
2x10 mm approx

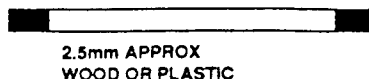

FERRITE
2-3 mm DIA

BRASS, FERRITE
FROM RF COIL.
FASTEN WITH
GLUE.

TUNER ALIGNMENT POINTS

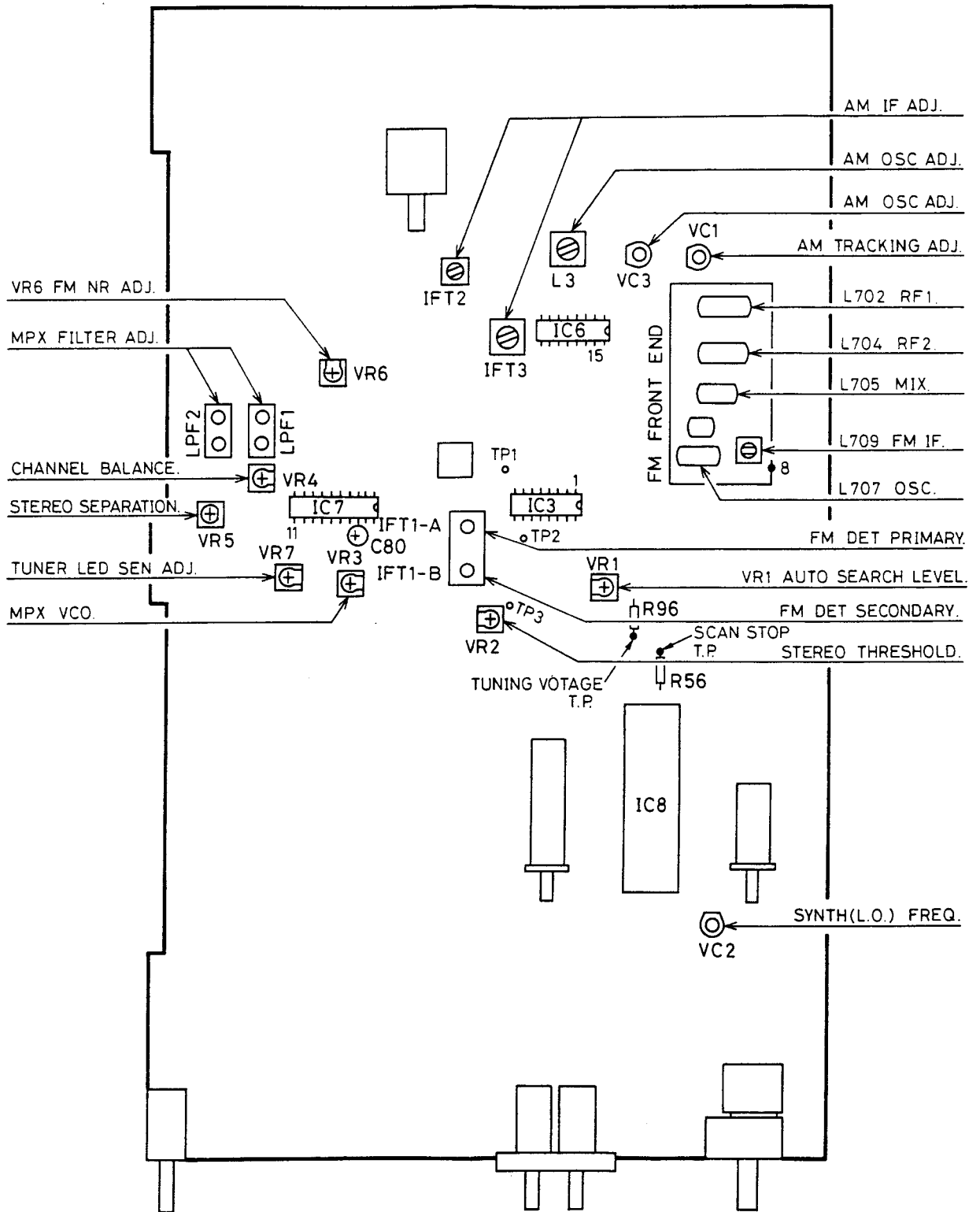

As possible, to pickup.

contact
as commonly
180
181
119
60
34
22

AMPLIFIER PCB LAYOUT

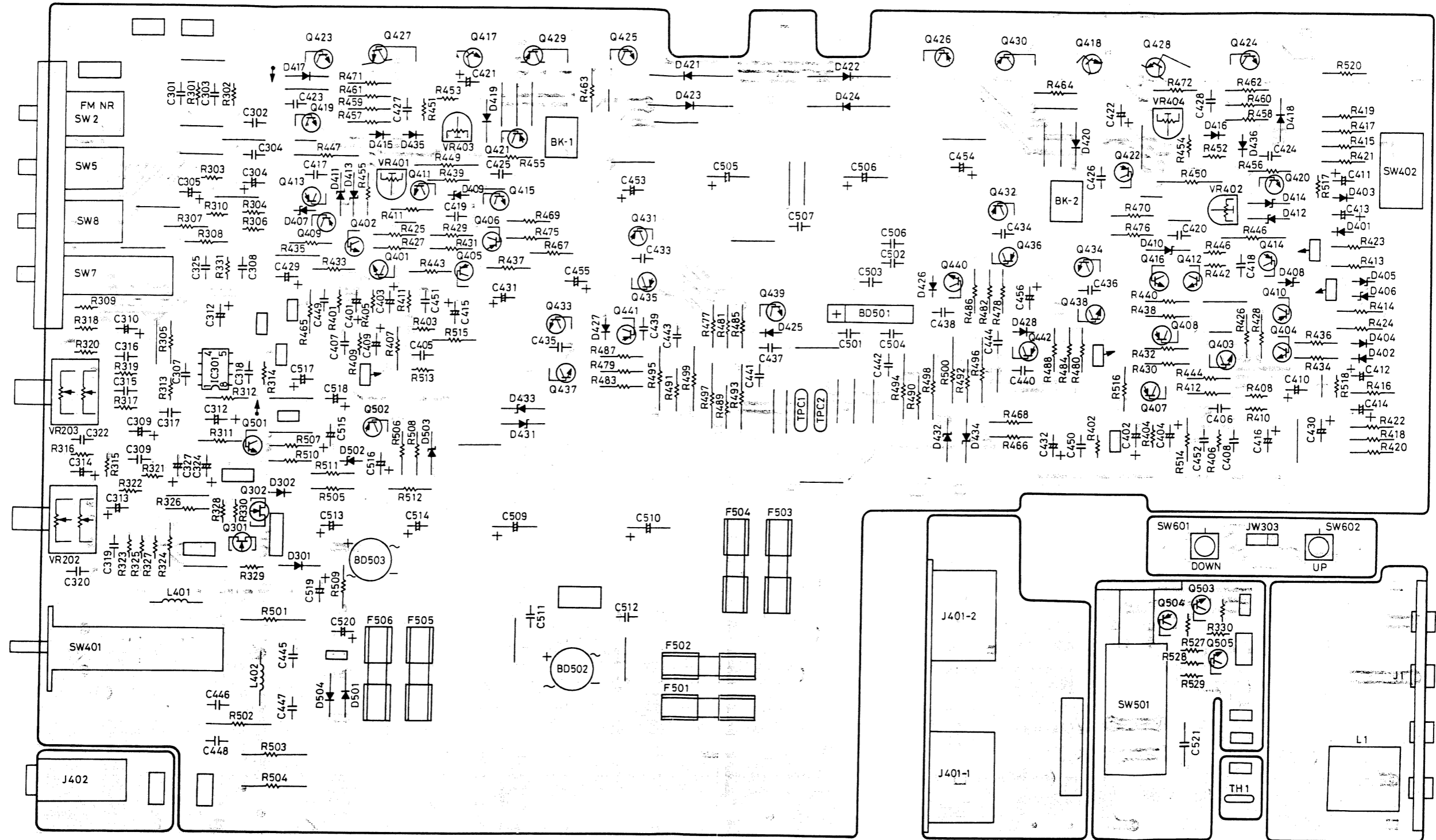

NAD 7240PE AMPLIFIER SCHEMATIC

Make leakage current or resistance measurements to determine that exposed metal parts are acceptably insulated from the supply circuit before returning the appliance to the customer.

Leakage current should not exceed 0.5 mA as measured through a 1.5 Kohm resistor paralleled by a 0.15 mfd capacitor to the earth ground.

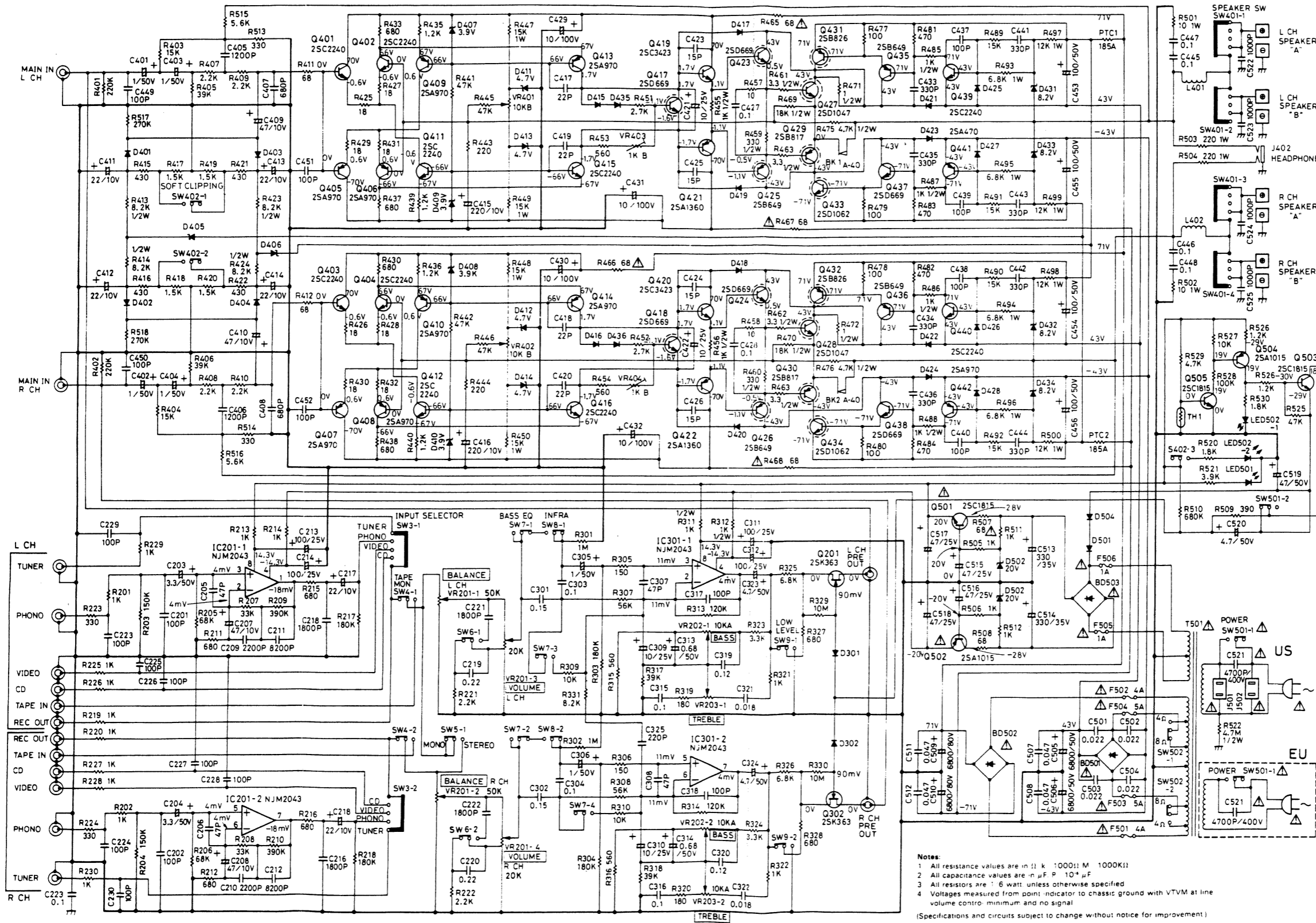

Symbol No.	Value
R 489, 490, 491, 492	2.2k
C 437, 438, 439, 440	39pF
C 441, 442, 443, 444	560pF
Q 435, 436	BD680
Q 437, 438	BD679
D 421, 422, 423, 424	BY500-100

Notes:
 1 All resistance values are in Ω , k, 1000 Ω , M, 1000k Ω
 2 All capacitance values are in n, μ , p, 10 μ , μ F
 3 All resistors are 1/6 watt unless otherwise specified
 4 Voltages measured from point indicator to chassis ground with VTVM at line volume control minimum and no signal
 (Specifications and circuits subject to change without notice for improvement)

TUNER PCB LAYOUT

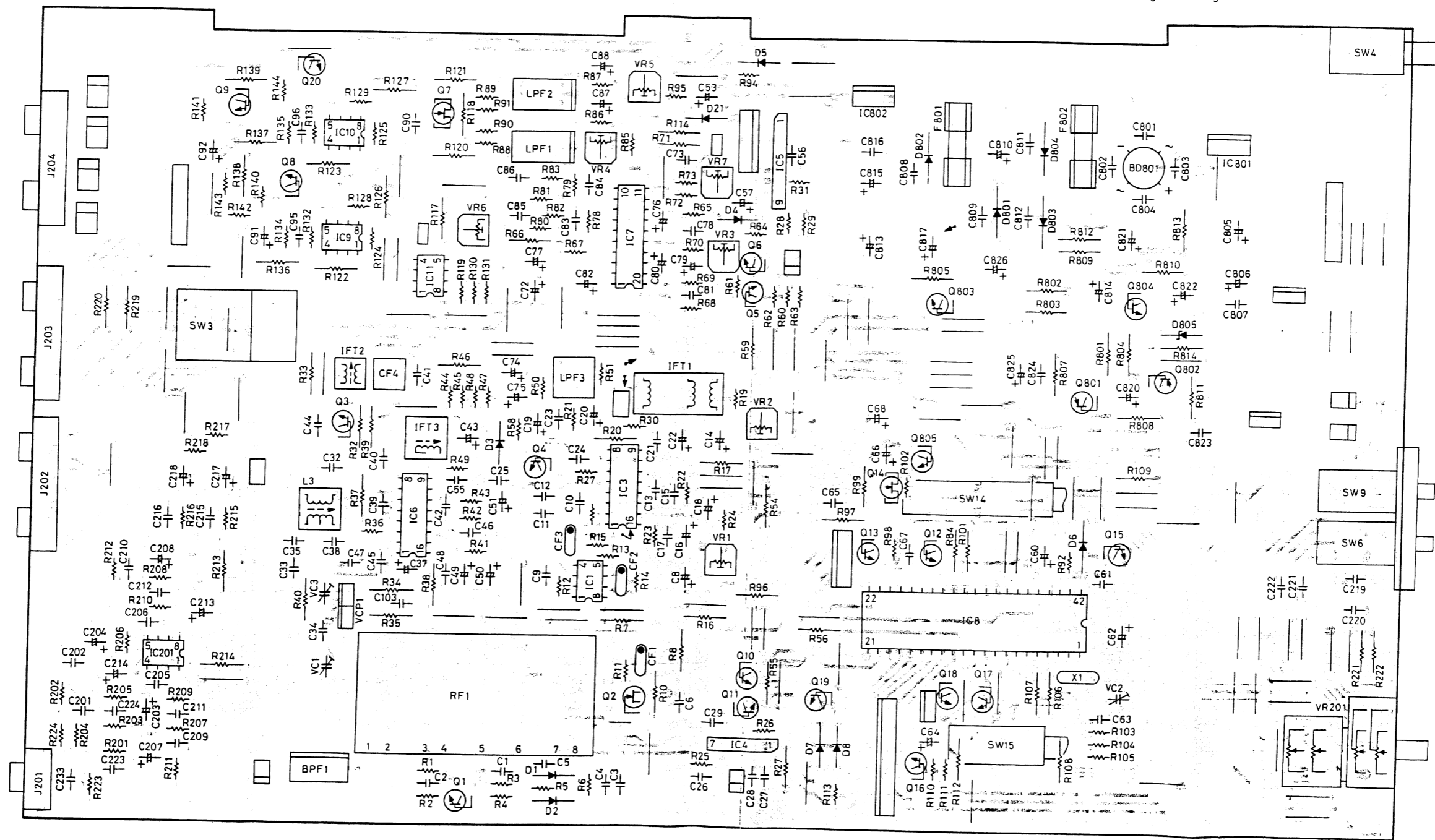

FRONT END SCHEMATIC

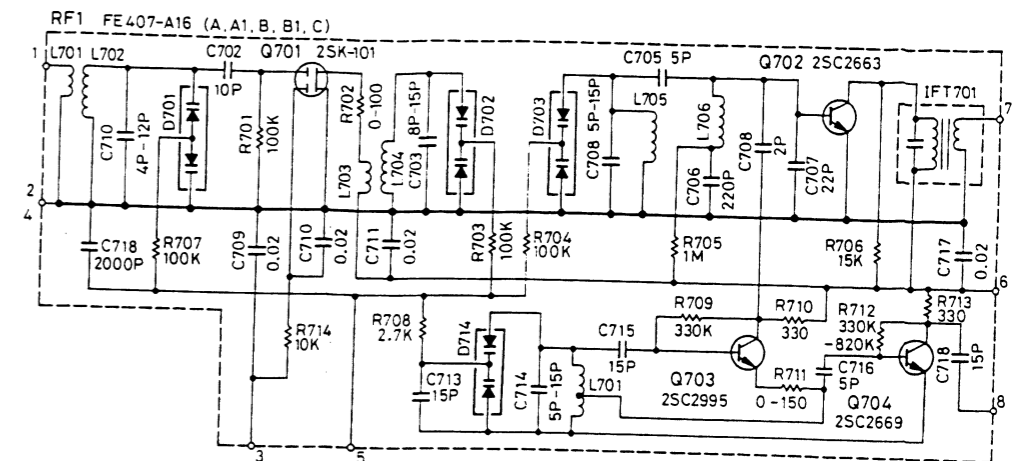

NAD 7240PE TUNER SCHEMATIC

Make leakage current or resistance measurements to determine that exposed metal parts are acceptably insulated from the supply circuit before returning the appliance to the customer.

Leakage current should not exceed 0.5 mA as measured through a 1.5 Kohm resistor paralleled by a 0.15 mfd capacitor to the earth ground.

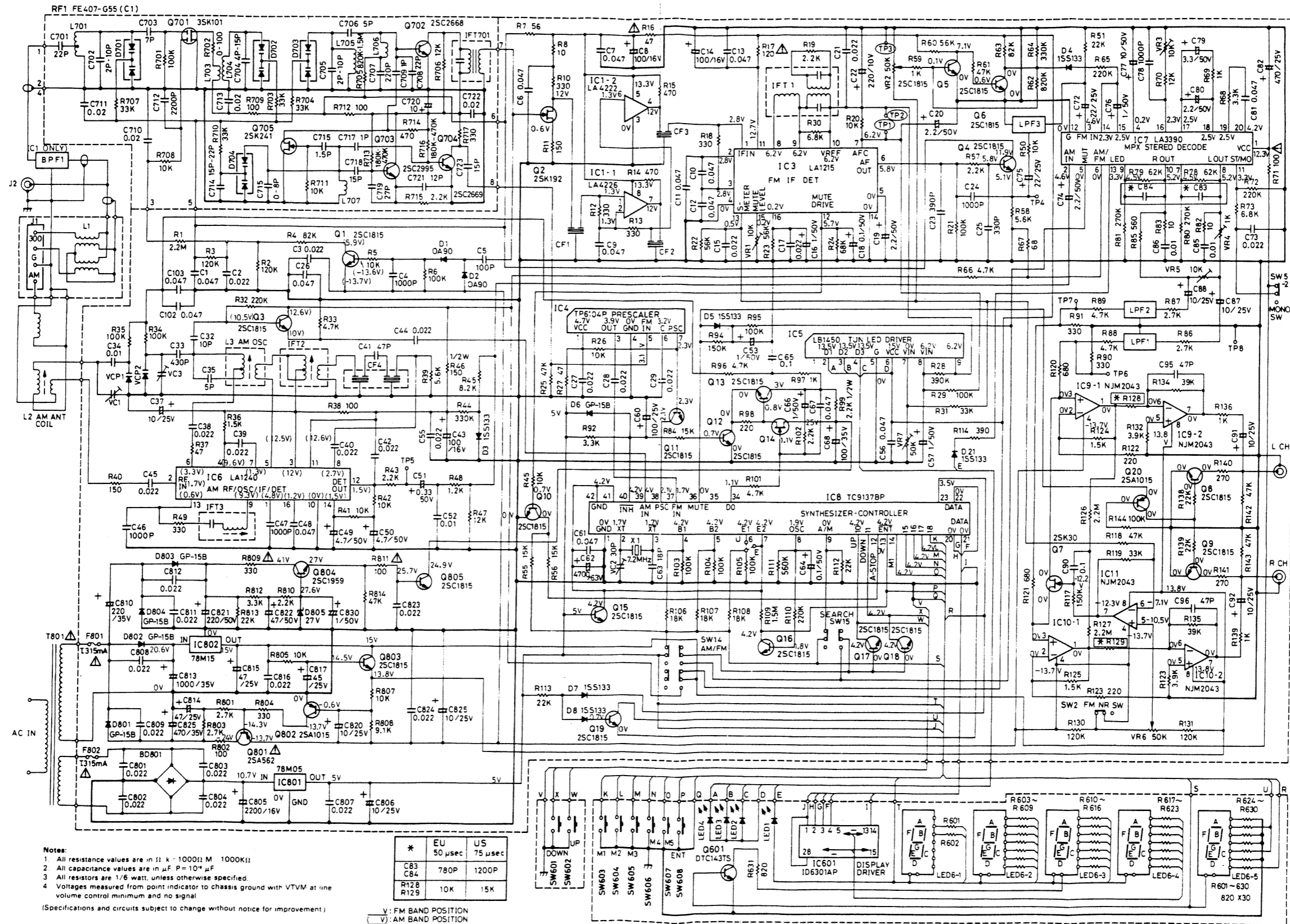

Notes:
 1. All resistance values are in Ω , k, 1000 Ω ; M, 1000k Ω ;
 2. All capacitance values are in μ F, P = 10⁻¹² μ F
 3. All resistors are 1/8 watt, unless otherwise specified.
 4. Voltages measured from point indicator to chassis ground with VTVM at line volume control minimum and no signal.
 (Specifications and circuits subject to change without notice for improvement.)

	EU	US
* C83	50 μ sec	75 μ sec
C84	780P	1200P
R128	10K	15K
R129	10K	15K

V: FM BAND POSITION
 V: AM BAND POSITION

**POWER TRANSFORMER
PRIMARY WIRING
(MULTI-VOLTAGE)**

AMPLIFIER PCB WIRING DIAGRAM

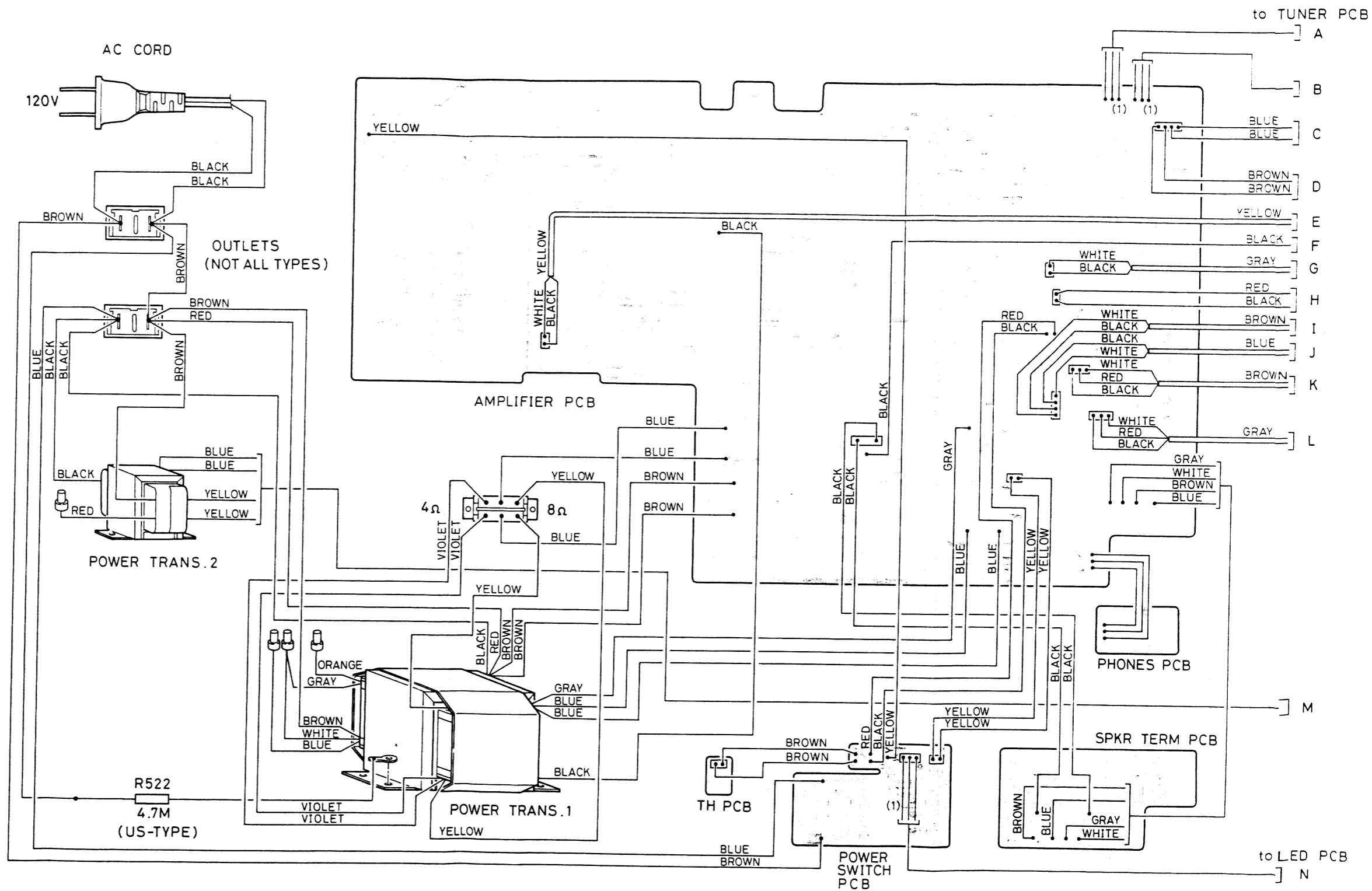
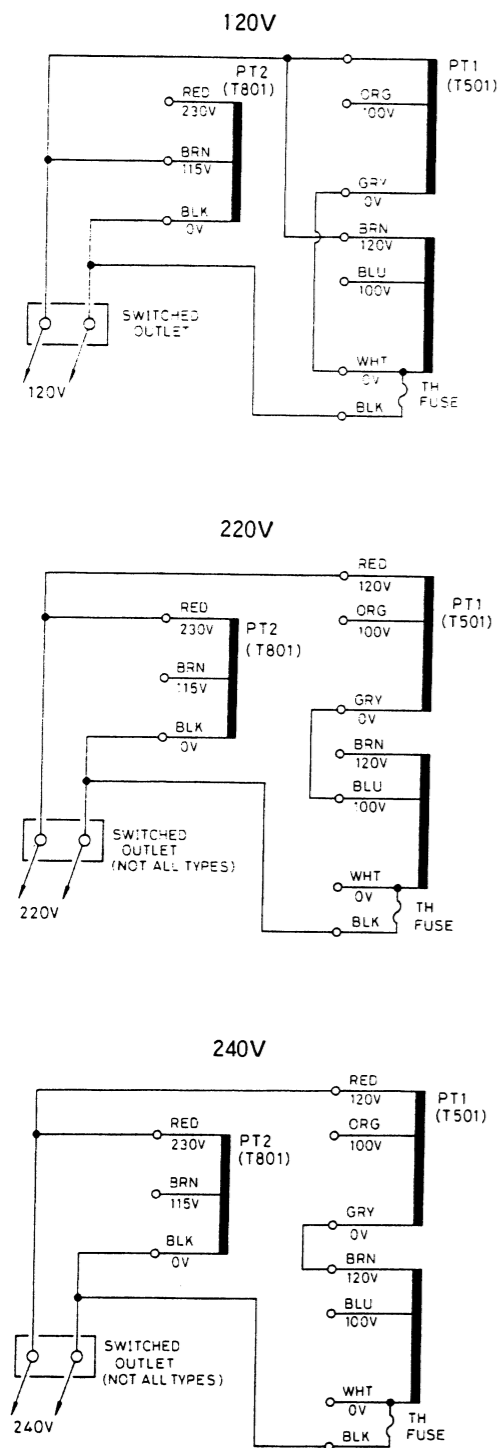

NOTE: WHEN CHANGING MAINS VOLTAGE, ALSO CHECK FM DE-EMPHASIS (50/75μ SEC) (C 83, C 84, R 128, R 129), AND AM TUNING STEP (9/10 kHz) (IC 8 PIN 6).

TUNER PCB WIRING DIAGRAM

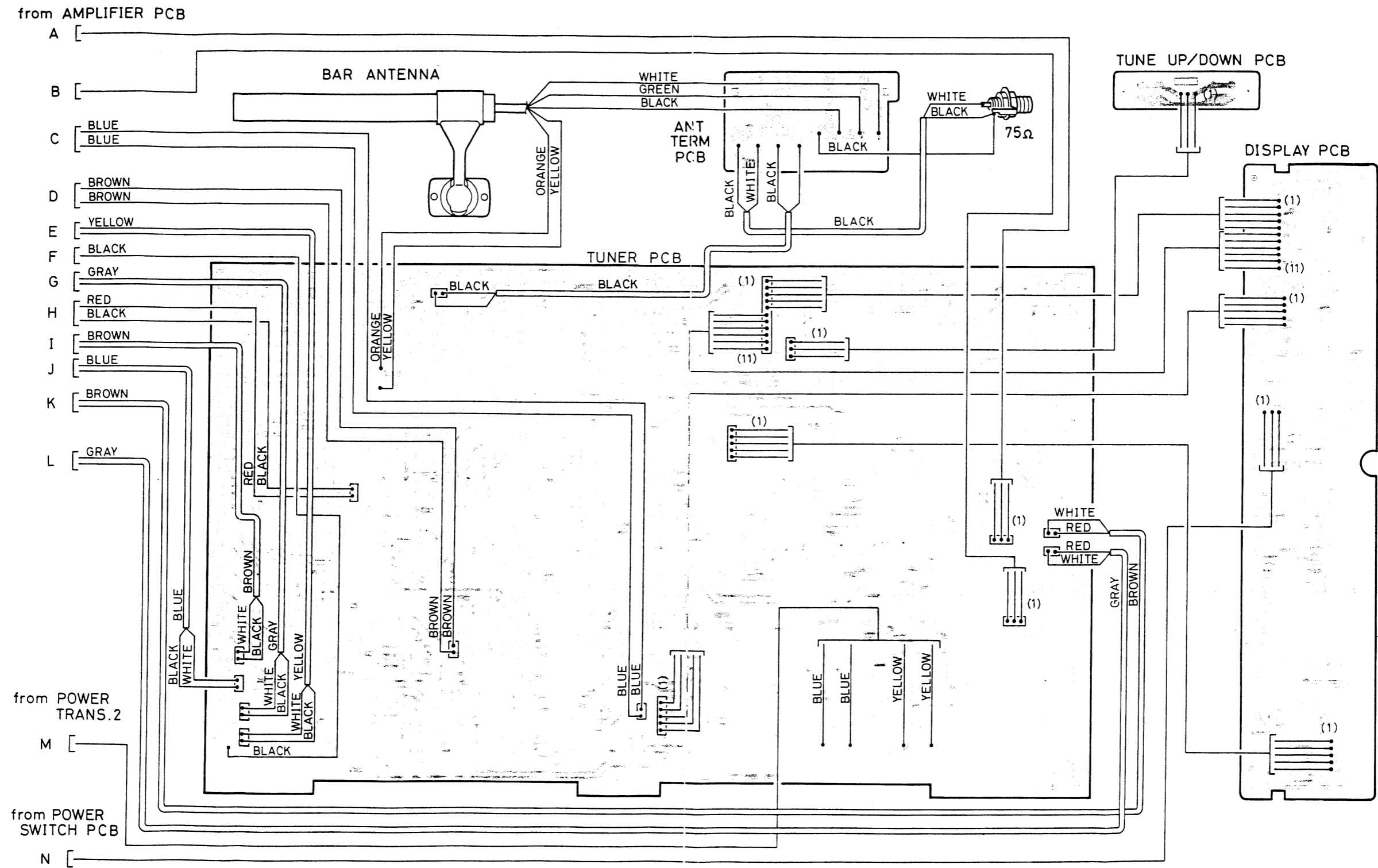

AMPLIFIER PCB PARTS LOCATION

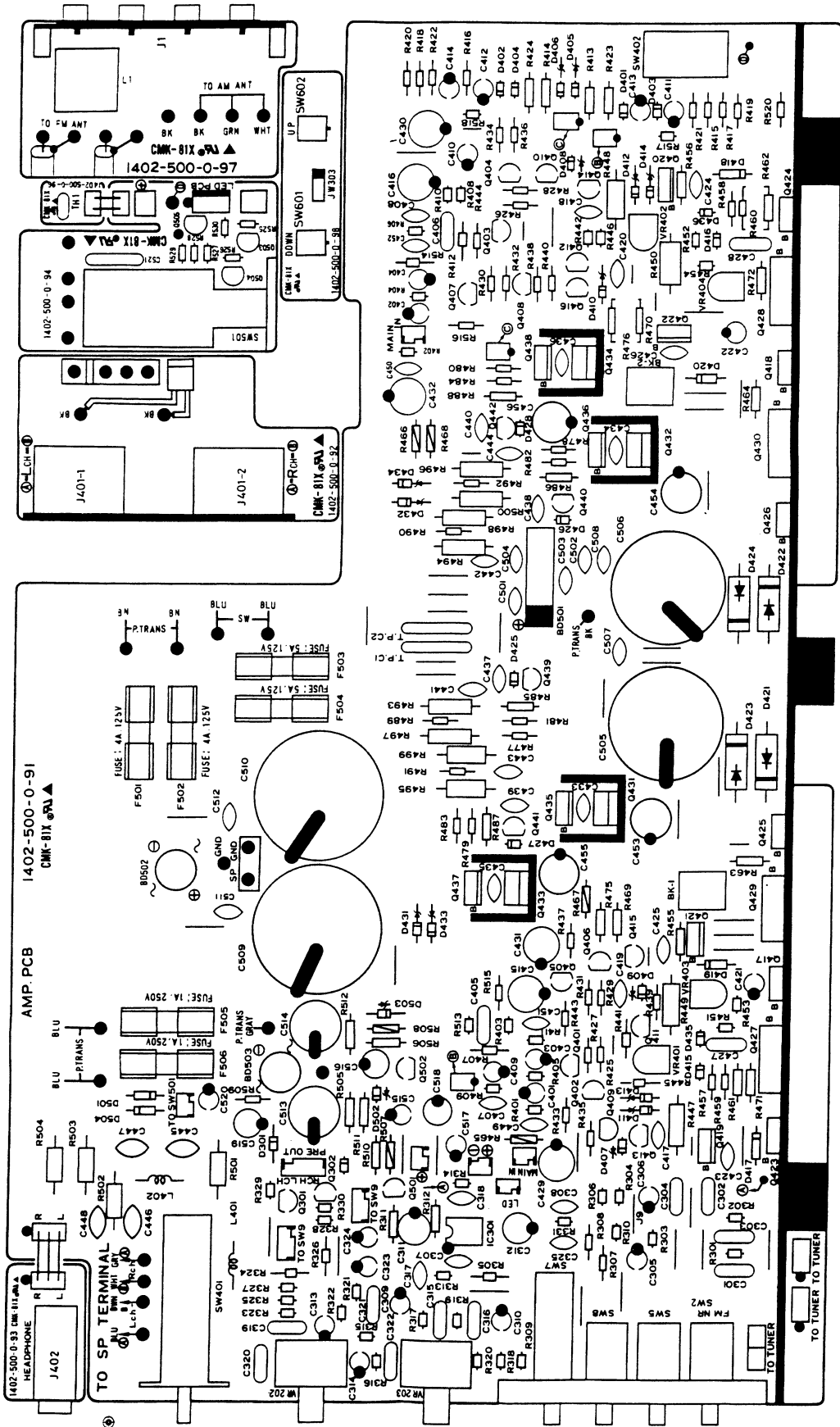

TUNER PCB PARTS LOCATION

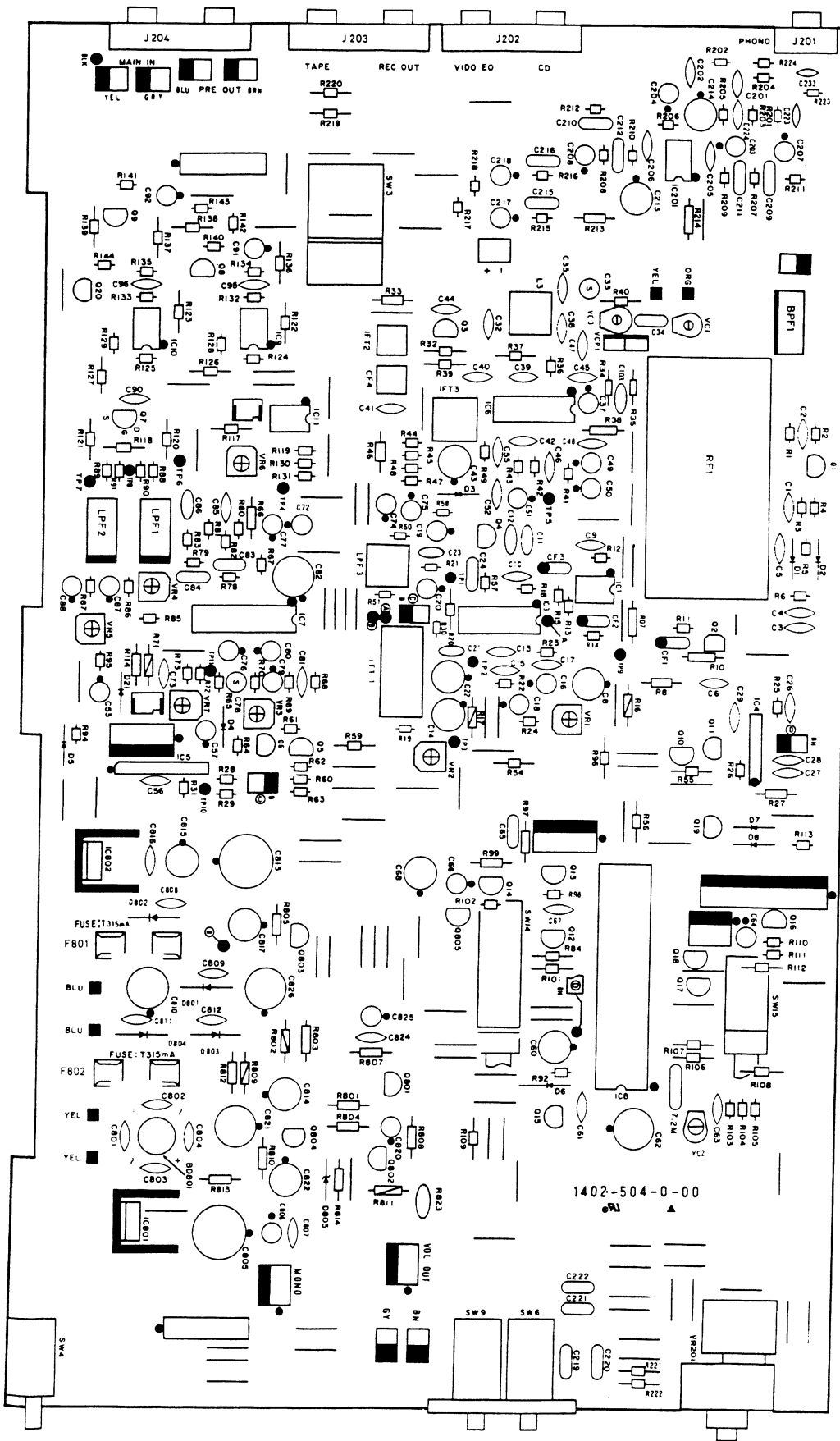

ELECTRICAL PARTS LIST

SYMBOL NO.	PARTS NO.	DESCRIPTION	REF	SYMBOL NO.	PARTS NO.	DESCRIPTION	REF
R 1, 126, 127	0920-862-2-54	Res, Carb, 2.2M +-5% 1/ 6W		R 85, 315, 316, 453, 454	0920-865-6-14	Res, Carb, 560 +-5% 1/ 6W	
R 2, 3, 130, 131, 313, 314,	0920-861-2-44	Res, Carb, 120k +-5% 1/ 6W		R 86, 87, 451, 452	0920-862-7-24	Res, Carb, 2.7k +-5% 1/ 6W	
R 4, 63	0920-868-2-34	Res, Carb, 82k +-5% 1/ 6W		R 90, 91, 319, 320	0920-861-8-14	Res, Carb, 180 +-5% 1/ 6W	
R 5, 26, 41, 42, 50, 54, 309, 310, R 527	0920-861-0-34	Res, Carb, 10k +-5% 1/ 6W	A, A 1	R 94, 117, 203, 204	0920-861-5-44	Res, Carb, 150k +-5% 1/ 6W	
R 5, 26, 41, 42, 50, 54, 128, 129, R 309, 310, 527	0920-861-0-34	Res, Carb, 10k +-5% 1/ 6W	B, B 1, C, C 1	R 97, 213, 214	0920-811-0-24	Res, Carb, 1k +-5% 1/ 4W	
R 6, 21, 29, 34, 35, 95, 103, 104, R 105, 144, 528	0920-861-0-44	Res, Carb, 100k +-5% 1/ 6W		R 98, 122, 123, 443, 444	0920-862-2-14	Res, Carb, 220 +-5% 1/ 6W	
R 7	0920-815-6-04	Res, Carb, 56 +-5% 1/ 4W		R 99	0925-422-2-24	Res, Metal 2.2k +-5% 1/ 2W	
R 8	0920-811-0-04	Res, Carb, 10 +-5% 1/ 4W		R 106, 107, 108	0920-861-8-34	Res, Carb, 18k +-5% 1/ 6W	
R 10, 804	0920-813-3-14	Res, Carb, 330 +-5% 1/ 4W		R 111	0920-865-6-44	Res, Carb, 560k +-5% 1/ 6W	
R 11, 40, 305, 306	0920-861-5-14	Res, Carb, 150 +-5% 1/ 6W		R 114	0920-813-9-14	Res, Carb, 390 +-5% 1/ 4W	
R 12, 13, 18, 49, 90, 91, 223, 224, R 513, 514	0920-863-3-14	Res, Carb, 330 +-5% 1/ 6W		R 132, 133	0920-863-9-24	Res, Carb, 3.9k +-5% 1/ 6W	
R 14, 15, 481, 482, 483, 484	0920-864-7-14	Res, Carb, 470 +-5% 1/ 6W		R 134, 135, 317, 318, 405, 406	0920-863-9-34	Res, Carb, 39k +-5% 1/ 6W	
△ R 16	0921-114-7-04	Res, Carb, 47 +-5% 1/ 4W		R 140, 141	0920-862-7-14	Res, Carb, 270 +-5% 1/ 6W	
△ R 17	0921-111-2-14	Res, Carb, 120 +-5% 1/ 4W		R 217, 218, 303, 304	0920-861-8-44	Res, Carb, 180k +-5% 1/ 6W	
R 19, 43, 57, 102, 221, 222, 407, R 408, 409, 410	0920-862-2-24	Res, Carb, 2.2k +-5% 1/ 6W		R 301, 302	0920-861-0-54	Res, Carb, 1M +-5% 1/ 6W	
R 20, 47, 70	0920-861-2-34	Res, Carb, 12k +-5% 1/ 6W		R 311, 312	0920-021-0-24	Res, Carb, 1k +-5% 1/ 2W	
R 22, 23, 60, 307, 308	0920-865-6-34	Res, Carb, 56k +-5% 1/ 6W		R 329, 330	0920-861-0-64	Res, Carb, 10M +-5% 1/ 6W	
R 24, 205, 206	0920-866-8-34	Res, Carb, 68k +-5% 1/ 6W		R 411, 412	0920-866-8-04	Res, Carb, 68 +-5% 1/ 6W	
R 25, 61, 118, 142, 143, 441, 442, R 445, 446, 525	0920-864-7-34	Res, Carb, 47k +-5% 1/ 6W		R 413, 414, 423, 424	0920-028-2-24	Res, Carb, 8.2k +-5% 1/ 2W	
R 27	0920-814-7-04	Res, Carb, 47 +-5% 1/ 4W		R 415, 416, 421, 422	0920-864-3-14	Res, Carb, 430 +-5% 1/ 6W	
R 28, 209, 210	0920-863-9-44	Res, Carb, 390k +-5% 1/ 6W		R 425, 426, 427, 428, 429, 430, 431, R 432	0920-861-8-04	Res, Carb, 18 +-5% 1/ 6W	
R 30, 73, 325, 326	0920-866-8-24	Res, Carb, 6.8k +-5% 1/ 6W		R 447, 448, 449, 450	0925-431-5-34	Res, Metal 15k +-5% 1W	
R 31, 119, 207, 208	0920-863-3-34	Res, Carb, 33k +-5% 1/ 6W		R 455, 456, 485, 486, 487, 488	0925-421-0-24	Res, Metal 1k +-5% 1/ 2W	
R 32, 65, 72, 110, 401, 402	0920-862-2-44	Res, Carb, 220k +-5% 1/ 6W		R 459, 460	0925-423-3-14	Res, Metal 330 +-5% 1/ 2W	
R 33, 88, 89, 96, 101, 529	0920-864-7-24	Res, Carb, 4.7k +-5% 1/ 6W		R 461, 462, 463, 464	0925-423-3-84	Res, Metal 3.3 +-5% 1/ 2W	
R 36, 109, 124, 125, 417, 418, 419, R 420	0920-861-5-24	Res, Carb, 1.5k +-5% 1/ 6W		△ R 465, 466, 467, 468, 507, 508	0921-116-8-04	Res, Carb, 68 +-5% 1/ 2W	
R 37	0920-864-7-04	Res, Carb, 47 +-5% 1/ 6W		R 469, 470	0920-021-8-34	Res, Carb, 18k +-5% 1/ 2W	
R 38	0920-811-0-14	Res, Carb, 100 +-5% 1/ 4W		R 471, 472	0920-020-1-04	Res, Carb, 1 +-5% 1/ 2W	
R 39, 58, 515, 516	0920-865-6-24	Res, Carb, 5.6k +-5% 1/ 6W		R 475, 476	0920-024-7-24	Res, Carb, 4.7k +-5% 1/ 2W	
R 44, 64	0920-863-3-44	Res, Carb, 330k +-5% 1/ 6W		R 477, 478, 479, 480	0920-861-0-14	Res, Carb, 100 +-5% 1/ 6W	
R 45, 331	0920-868-2-24	Res, Carb, 8.2k +-5% 1/ 6W		R 493, 494, 495, 496	0925-436-8-24	Res, Metal 6.8k +-5% 1W	
R 46	0925-421-5-14	Res, Metal 150 +-5% 1/ 2W		R 497, 498, 499, 500	0925-431-2-34	Res, Carb, 12k +-5% 1W	
R 48, 435, 436, 439, 440	0920-861-2-24	Res, Carb, 1.2k +-5% 1/ 6W		R 501, 502	0925-431-0-04	Res, Carb, 10 +-5% 1W	
R 51, 112, 113, 138, 139, 526	0920-862-2-34	Res, Carb, 22k +-5% 1/ 6W		R 503, 504	0925-432-2-14	Res, Carb, 220 +-5% 1W	
R 55, 56, 84, 128, 129, 403, 404, R 489, 490, 491, 492	0920-861-5-34	Res, Carb, 15k +-5% 1/ 6W	A, A 1	R 509	0920-863-9-14	Res, Carb, 390 +-5% 1/ 6W	
R 55, 56, 84, 403, 404, 489, 490, R 491, 492	0920-861-5-34	Res, Carb, 15k +-5% 1/ 6W	B, B 1, C, C 1	R 510	0920-816-8-44	Res, Carb, 680k +-5% 1/ 4W	
R 59, 69, 136, 137, 201, 202, 219, R 220, 225, 226, 227, 228, 321, 322, R 505, 506, 511, 512	0920-861-0-24	Res, Carb, 1k +-5% 1/ 6W		R 520, 530	0920-861-8-24	Res, Carb, 1.8k +-5% 1/ 6W	
R 62	0920-868-2-44	Res, Carb, 820k +-5% 1/ 6W		R 522	0920-024-7-54	Res, Carb, 4.7M +-5% 1/ 2W	A, A 1
R 66	0920-814-7-24	Res, Carb, 4.7k +-5% 1/ 4W		R 601 to 631	0920-868-2-14	Res, Carb, 820 +-5% 1/ 6W	
R 67, 120, 121, 211, 212, 215, 216, R 327, 328, 433, 434, 437, 438	0920-866-8-14	Res, Carb, 680 +-5% 1/ 6W		R 801, 803	0920-812-7-24	Res, Carb, 2.7k +-5% 1/ 4W	
R 68, 92, 323, 324	0920-863-3-24	Res, Carb, 3.3k +-5% 1/ 6W		R 805, 807	0920-811-0-34	Res, Carb, 10k +-5% 1/ 4W	
△ R 71, 802, 811	0921-111-0-14	Res, Carb, 100 +-5% 1/ 4W		R 808	0920-819-1-24	Res, Carb, 9.1k +-5% 1/ 4W	
R 78, 79	0920-866-2-34	Res, Carb, 62k +-5% 1/ 6W		△ R 809	0921-113-3-14	Res, Carb, 330 +-5% 1/ 4W	
R 80, 81, 517, 518	0920-862-7-44	Res, Carb, 270k +-5% 1/ 6W		R 810	0920-812-2-24	Res, Carb, 2.2k +-5% 1/ 4W	
R 82, 83, 457, 458	0920-861-0-04	Res, Carb, 10 +-5% 1/ 6W		R 812	0920-813-3-24	Res, Carb, 3.3k +-5% 1/ 4W	
				R 813	0920-812-2-34	Res, Carb, 22k +-5% 1/ 4W	
				R 814	0920-814-7-34	Res, Carb, 47k +-5% 1/ 4W	
				C 1, 6, 7, 9, 10, 11, 12, 13, 26, 48,	0931-554-7-39	Cap, Cer 0.047uF +80-20% 50V	
				C 56, 61, 67, 103			
				C 2, 3, 15, 17, 21, 27, 28, 29, 39, C 40, 44, 45, 55, 73, 801, 802, 803, C 804, 807, 808, 809, 811, 812, 816, C 823, 824	0931-552-2-39	Cap, Cer 0.022uF +80-20% 50V	
				C 4, 46, 47, 522, 523, 524, 525	0931-251-0-25	Cap, Cer 1000pF +-10% 50V	
				C 5, 201, 202	0931-251-0-15	Cap, Cer 100pF +-10% 50V	

SYMBOL NO.	PARTS NO.	DESCRIPTION	REF
C 8, 14, 43	0937-821-0-16	Cap, El 100uF +-20%	16V
C 16, 53, 57, 66, 76, 305, 306, 401, 402, 403, 404	0937-850-1-06	Cap, El 1uF +-20%	50V
C 18, 64	0937-851-0-96	Cap, El 0.1uF +-20%	50V
C 19, 20, 74, 80	0937-852-2-86	Cap, El 2.2uF +-20%	50V
C 22	0937-812-2-16	Cap, El 220uF +-20%	10V
C 23	0931-253-9-15	Cap, Cer 390pF +-10%	50V
C 24	0933-851-0-24	Cap, Poly 1000pF +-5%	50V
C 32	0930-201-0-04	Cap, Cer 10pF +-5%	50V
C 33	0932-654-3-14	Cap, Styrol 430pF +-5%	50V
C 34	0933-851-0-34	Cap, Poly 0.01uF +-5%	50V
C 35	0930-200-5-00	Cap, Cer 5pF +-0.25pF	50V
C 37, 77, 87, 88, 91, 92, 309, 310, 421, 422, 806, 820, 825	0937-831-0-06	Cap, El 10uF +-20%	25V
C 38, 42	0938-632-2-35	Cap, Cer 0.022uF +-10%	25V
C 41, 95, 96, 205, 206, 307, 308	0930-204-7-04	Cap, Cer 47pF +-5%	50V
C 49, 50, 323, 324, 520	0937-854-7-86	Cap, El 4.7uF +-20%	50V
C 51	0937-853-3-96	Cap, El 0.33uF +-20%	50V
C 52, 85, 86	0938-631-0-35	Cap, Cer 0.01uF +-10%	25V
C 60, 213, 214, 311, 312	0937-831-0-16	Cap, El 100uF +-20%	25V
C 62	0938-904-7-26	Cap, El 4700uF +-20%	6.3V
C 63	0930-214-8-04	Cap, Cer 18pF +-5%	50V
C 65	0933-451-0-44	Cap, Poly 0.1uF +-5%	50V
C 68	0937-841-0-16	Cap, El 100uF +-20%	35V
C 72, 75, 217, 218, 411, 412, 413, 414	0937-832-2-06	Cap, El 22uF +-20%	25V
C 78	0932-651-0-24	Cap, Styrol 1000pF +-5%	50V
C 79, 203, 204	0937-853-3-86	Cap, El 3.3uF +-20%	50V
C 81	0938-634-7-35	Cap, Cer 0.047uF +-10%	25V
C 82	0938-934-7-16	Cap, El 470uF +-20%	25V
C 83, 84	0933-851-2-24	Cap, Poly 1200pF +-5%	50V
C 83, 84	0939-908-9-00	Cap, Styrol 780pF +-2%	50V
C 90, 233, 445, 446, 447, 448	0939-904-7-00	Cap, Cer 0.1uF +-80-20%	50V
C 102	0931-454-7-39	Cap, Cer 0.047uF +-80-20%	50V
C 207, 208, 409, 410, 515, 516, 517, 518, 815, 817	0937-834-7-06	Cap, El 47uF +-20%	25V
C 209, 210	0933-852-2-24	Cap, Poly 2200pF +-5%	50V
C 211, 212	0933-858-2-24	Cap, Poly 8200pF +-5%	50V
C 215, 216, 221, 222	0933-851-8-24	Cap, Poly 1800pF +-5%	50V
C 219, 220	0933-452-2-44	Cap, Poly 0.22uF +-5%	50V
C 223, 224, 225, 226, 227, 228	0930-205-6-04	Cap, Cer 56pF +-5%	50V
C 301, 302	0933-851-5-46	Cap, Poly 0.15uF +-20%	50V
C 303, 304, 315, 316, 427, 428	0933-851-0-45	Cap, Poly 0.1uF +-10%	50V
C 313, 314	0937-856-8-96	Cap, El 0.68uF +-20%	50V
C 317, 318, 437, 438, 439, 440, 449, 450, 451, 452	0930-201-0-14	Cap, Cer 100pF +-5%	50V
C 319, 320	0933-851-2-46	Cap, Poly 0.12uF +-20%	50V
C 321, 322	0933-851-8-35	Cap, Poly 0.018uF +-10%	50V
C 325	0930-202-2-14	Cap, Cer 220pF +-5%	50V
C 405, 406	0933-851-2-25	Cap, Poly 1200pF +-10%	50V
C 407, 408	0930-206-8-14	Cap, Cer 680pF +-5%	50V
C 415, 416	0937-822-2-16	Cap, El 220uF +-20%	16V
C 417, 418, 419, 420	0930-202-2-04	Cap, Cer 22pF +-5%	50V
C 423, 424, 425, 426	0930-201-5-04	Cap, Cer 15pF +-5%	50V
C 429, 430, 431, 432	0935-971-0-06	Cap, El 10uF +-20%	100V
C 433, 434, 435, 436, 441, 442, 443, 444	0930-203-3-14	Cap, Cer 330pF +-5%	50V

SYMBOL NO.	PARTS NO.	DESCRIPTION	REF
C 453, 454, 455, 456	0937-851-0-16	Cap, El 100uF +-20%	50V
C 501, 502, 503, 504	0939-904-5-00	Cap, Cer 0.022uF +-80-20%	50V
C 505, 506	0939-908-4-00	Cap, El 6800uF +-20%	50V
C 507, 508, 511, 512	0939-904-6-00	Cap, Cer 0.047uF +-80-20%	50V
C 509, 510	0939-908-5-00	Cap, El 6800uF +-20%	80V
C 513, 514	0938-943-3-16	Cap, El 330uF +-20%	35V
C 519, 814, 822	0937-854-7-06	Cap, El 47uF +-20%	50V
C 521	0939-921-0-00	Cap, Cer 4700pF +-10%	400V
	or 0939-922-0-00	Cap, Cer 4700pF +-10%	400V
C 601	0938-931-0-06	Cap, El 10uF +-20%	25V
C 805	0938-922-2-26	Cap, El 2200uF +-20%	16V
C 810	0938-924-2-16	Cap, El 220uF +-20%	35V
C 813	0938-941-0-26	Cap, El 1000uF +-20%	35V
C 821	0938-952-2-16	Cap, El 220uF +-20%	50V
C 826	0938-944-7-16	Cap, El 470uF +-20%	35V
Q 1, 3, 4, 5, 6, 8, 10, 11, 12, 13, 15, 16, 17, 18, 19, 501, 503, 505, 803, 805	0906-200-4-55	Tr, 2SC 1815-GR	
Q 2	0909-000-5-55	Tr, 2SK 192A-GR	
Q 7	0909-000-2-55	Tr, 2SK 30A-TM-GR	
Q 14	0909-001-9-03	Tr, 2SK 40-C	
Q 20, 502, 504, 802	0906-200-2-55	Tr, 2SA 1015-GR	
Q 301, 302	0909-001-8-55	Tr, 2SK 363-GR	
Q 401, 402, 403, 404, 411, 412, 415, 416, 439, 440	0906-207-6-55	Tr, 2SC 2240-GR	
Q 405, 406, 407, 408, 409, 410, 413, 414, 441, 442	0906-207-7-55	Tr, 2SA 970-GR	
Q 417, 418, 423, 424, 437, 438	0903-006-3-03	Tr, 2SD 669A-C	
Q 419, 420	0902-012-2-25	Tr, 2SC 3423-Y	
Q 421, 422	0900-005-8-25	Tr, 2SA 1360-Y	
Q 425, 426, 435, 436	0901-003-8-03	Tr, 2SB 649A-C	
Q 427, 428	0903-006-4-05	Tr, 2SD 1047-E	
Q 429, 430	0901-003-9-05	Tr, 2SB 817-E	
Q 431, 432	0904-005-7-00	Tr, BD912	
Q 433, 434	0904-005-6-00	Tr, BD911	
Q 601	0904-004-1-00	Tr, DTC 143TS	
Q 801	0906-207-9-25	Tr, 2SA 562-Y	
Q 804	0906-207-8-25	Tr, 2SC 1959-Y	
D 1, 2	0914-018-4-00	Diode OA90A-M	
D 3, 4, 5, 7, 8, 21	0915-003-9-00	Diode 1SS 133	
	or 0915-003-1-00	Diode MA 165	
D 6, 501, 504, 801, 802, 803, 804	0913-005-7-00	Diode GP-15B	
D 301, 302, 401, 402, 403, 404, 415, 416, 425, 426, 427, 428, 435, 436	0914-004-7-00	Diode 1N 4148	
D 405, 406	0915-010-7-03	Diode-Zener RD15ESB3	
D 407, 408, 409, 410	0915-009-6-01	Diode-Zener RD3.9ESB1	
D 411, 412, 413, 414	0915-009-8-02	Diode-Zener RD4.7ESB2	
D 417, 418, 419, 420	0915-014-2-00	Diode 1SS 81	
D 421, 422, 423, 424	0913-007-3-00	Diode RGP 30B	
D 431, 432, 433, 434	0915-008-5-02	Diode-Zener RD8.2ESB2	
D 502, 503	0915-001-0-03	Diode-Zener RD20ESB3	
D 805	0915-011-3-04	Diode-Zener RD27ESB4	
BD501	0913-007-4-00	Diode KBU 6D	
BD502, 503, 801	0913-002-7-00	Diode 2WO 2	

SYMBOL NO.	PARTS NO.	DESCRIPTION	REF
LED 1	0916-021-8-00	LED, SLB-25YY3	
LED 2, 4	0916-021-5-00	LED, SLT-25YY3	
LED 3	0916-021-6-00	LED, SLB-24MG 3	
LED 5	0916-022-1-00	LED, SPB-25MVW	
LED 6	0916-021-9-00	LED-Display LA 3055-11	
VP1	0914-033-2-00	Diode KV1236Z 2	
IC 1	0911-090-5-00	IC, LA 1222	
IC 3	0911-090-6-00	IC, LA 1235	
IC 4	0911-044-1-00	IC, TD6104P	
IC 5	0911-090-7-00	IC, LB 1450	
IC 6	0911-090-8-00	IC, LA 1240	
IC 7	0911-090-9-00	IC, LA 3390	
IC 8	0911-091-0-00	IC, TC9137BP	
IC 9, 10 11, 201, 301	0911-091-2-00	IC, UPC 4570C	
IC 601	0911-058-9-00	IC, TD6301AP	
IC 801	0911-014-4-00	IC, NJM 78M 05A	
IC 802	0911-058-7-00	IC, NJM 78M 15A	
IFT 1	0012-191-0-00	IFT-FM	
IFT 2	0012-313-0-00	IFT-AM	
IFT 3	0012-314-0-00	IFT-AM	
L 1	0013-505-0-00	Coil-FM ANT	
L 2	0016-901-0-00	Antenna-Bar	
L 3	0014-695-0-00	Coil-AM OSC	
L 401, 402	0013-093-0-00	Coil, Spring	
LPF 1, 2	0039-873-0-00	Filter-MPX	
LPF 3	0039-872-0-00	Filter-Low Pass	
CF 1, 2, 3	0039-085-0-00	Filter, Ceramic-FM	
CF 4	0039-084-0-00	Filter, Ceramic-AM	
△ BK1, 2	0045-400-0-00 or 0045-401-0-00	Breaker Breaker	
△ F 501, 502	0045-078-0-00	Fuse, 4A/ 125V	A, A 1
△ F 501, 502	0045-089-0-00	Fuse, T, 4A/ 250V	B, B 1, C, C 1
△ F 503, 504	0045-079-0-00	Fuse, 5A/ 125V	A, A 1
△ F 503, 504	0045-090-0-00	Fuse, T, 5A/ 250V	B, B 1, C, C 1
△ F 505, 506	0045-047-0-00	Fuse, 1A/ 125V	A, A 1
△ F 505, 506	0045-007-1-21	Fuse, T, 1A/ 250V	B, B 1, C, C 1
△ F 801, 802	0045-027-0-21	Fuse, T, 315mA/ 250V	B, B 1, C, C 1
J1	0033-215-0-00	Terminal-Ant	
J2	0033-212-0-00	Jack-ANT	A, A 1
J2	0033-947-0-00	Socket-ANT	B, B 1, C, C 1
J201	0033-209-0-00	Jack-RCA, 2pin	
J202, 203, 204	0033-210-0-00	Jack-RCA, 4pin	
J401	0033-213-0-00	Terminal-Speaker	A, A 1, B, B 1, C 1
J401	0033-214-0-00	Terminal-Speaker	C
J402	0033-867-0-00	Jack-6.3mm, Headphone	
△ J501, 502	0033-036-0-00	Outlet-AC	A, A 1
TPC1, 2	0918-002-4-00	Thermistor, DRE 185A	

SYMBOL NO.	PARTS NO.	DESCRIPTION	REF
TH1	0918-002-5-00	Thermistor, PTH 487A-BC471	
RF1	0039-617-0-00	RF Module, FM Front/End	A, A 1, B, B 1, C
RF1	0039-618-0-00	RF Module, FM Front/End	C 1
SW2/ 5/ 7/ 8	0028-005-0-00	SW-Push, FM NR/Mono/Infra/Bass Eq	
SW3	0036-030-0-00	SW-Rotary, Input Select	
SW4	0028-006-0-00	SW-Push, Tape Monitor	
SW6/ 9	0028-004-0-00	SW-Push, Loudness/Low Level	
SW14	0028-008-0-00	SW-Push, AM/FM	
SW15	0028-007-0-00	SW-Push, Search	
SW401	0036-031-0-00	SW-Rotary, Speaker Select	
SW402	0028-240-0-00	SW-Slide, Soft Clipping	
△ SW501	0028-009-0-00	SW-Push, Power	A, A 1
△ SW501	0028-010-0-00	SW-Push, Power	B, B 1, C, C 1
SW502	0028-254-0-00	SW-Slide, Impedance Select	
SW601, 602, 603, 604, 605, 606, 607, 608	0028-810-0-00	SW-Tact	
△ T 501	0019-871-0-00	Trans-Power	
△ T 801	0019-872-0-00	Trans-Power	
VC 1, 2, 3	0030-425-0-00	Capacitor-Trimmer	
VR1, 3, 401, 402	0031-835-1-03	VR-Semi, 10kB	
VR2, 6, 7	0031-835-5-03	VR-Semi, 50kB	
VR4, 403, 404	0031-835-1-02	VR-Semi, 1kB	
VR5	0031-835-1-04	VR-Semi, 100kB	
VR201	0031-552-0-00	Volume/Balance Control, 20kB/ 50kB	
VR301, 302	0031-551-1-03	Tone Control, 10kA	
X 1	0038-085-0-00	Crystal, 7.2MHz	
SERIAL NO. 05541-up			
R 489, 490, 491, 492	0920-862-2-24	Res, Carb, 2.2k +-5% 1/ 6W	
C 437, 438, 439, 440	0930-203-9-04	Cap, Cer, 39pF +-5% 50V	
C 441, 442, 443, 444	0930-205-6-14	Cap, Cer, 560pF +-5% 50V	
Q 435, 436	0904-006-1-00	Tr, Darl, BD680	
Q 437, 438	0904-006-0-00	Tr, Darl, BD679	
D 421, 422, 423, 424	0913-007-8-00	Diode, BY500-100	

Product Safety Note: Products marked with a △ have special characteristics important to safety. Before replacing any of these components read carefully the product safety notice of this Service Manual. Don't degrade the safety of the product.

EXPLODED PARTS LIST

ITEM	PARTS NO.	NAME	QTY
1	0033-216-0-00	Earth Terminal	1
2	0034-485-0-00	Short Pin	2
3	0034-514-0-20	Lug Terminal	1
△ 4	0047-166-0-00	AC Cord	1
△ 4	0047-286-0-00	AC Cord	1
△ 4	0047-284-0-00	AC Cord	1
△ 4	0047-231-1-21	AC Cord	1
5	0062-599-0-00	Rubber Cushion	1
6	0064-610-0-00	Bush, SR-4N-4	2
7	0064-630-0-00	Wire Nut	4
8	0064-631-0-00	Lead-wire Clamp	20
9	0074-129-0-00	Caution Label	2
10	0074-157-0-00	Fuse Caution Label	2
11	0079-920-0-00	Foot, Rubber	4
12	1402-400-0-00	Spring, Joint	1
13	1402-730-0-00	AC-cover	1
14	1402-731-0-00	Sheet, Isolating	1
15	1402-732-0-00	Cover, Power Switch	1
16	1402-810-0-01	Panel, Front	1
17	1402-811-1-03	Panel, Rear	1
17	1402-815-0-03	Panel, Rear	1
17	1402-815-0-05	Panel, Rear	1
17	1402-815-0-04	Panel, Rear	1
18	1402-812-0-01	Case, Metal	1
19	1402-813-0-00	Cover, Bottom	1
20	1402-820-0-01	Window, Display	1
21	1402-860-0-01	Knob, Volume	1
22	1402-861-0-01	Knob, Blance	1
23	1402-862-0-01	Knob, Search	1
24	1402-863-0-01	Knob, Tuning	1
25	1402-864-0-01	Knob, AM/FM (Black)	1
26	1402-864-0-02	Knob, AM/FM (Beige)	1
27	1402-865-0-01	Knob, Push (Green)	1
28	1402-865-0-02	Knob, Push (Black)	7
29	1402-866-0-01	Knob, Memory	1
30	1402-867-0-01	Knob, Rotary	4
31	1402-869-0-00	Joint A	2
32	1402-870-0-00	Joint B	1
33	1402-871-0-00	Guide, Shaft	1
34	1402-872-0-00	Shaft	1
35	1402-874-0-00	Chassis, Front	1
36	1402-875-1-00	Angle L, Side	1
37	1402-876-1-00	Angle R, Side	1
38	1402-880-0-00	Plate, Lock	1
39	1402-889-0-00	Sheet, Bonding	1
40	0972-730-0-83	Screw-S Tite M3x 8 (Black)	10
41	0972-740-0-53	Screw-S Tite M4x 5	4
42	0973-230-0-83	Screw-B Tite M3x 8 (Black)	10
43	0973-230-0-85	Screw-B Tite M3x 8	9
44	0973-526-0-85	Screw-P Tite M2.6x 8	5
45	0975-030-0-63	Screw-C Tite M3x 6 (Black)	8
46	0975-030-0-65	Screw-C Tite M3x 6	28
47	0975-130-0-55	Screw-S Tite M3x 5	2
48	0975-140-0-63	Screw-S Tite M4x 6 (Black)	6
49	0981-105-0-11	E-Ring, 5mm	1
50	0973-230-0-83	Screw-B Tite M3x 8 (Black)	2
50	0973-230-1-01	Screw-B Tite M3x 10	2

A, A 1

B

B 1

C, C 1

A, A 1

A, A 1

A, A 1

A, A 1

B, B 1

C

C 1

A, A 1

B, B 1, C, C 1

ITEM	PARTS NO.	NAME	QTY
51	0064-641-0-00	Rivet, Plastic	2
52	1420-555-0-00	Cover	1
53	0065-370-0-00	Plate J, Mount	1
54	0987-101-0-00	Washer-Lug 4x 15x 0.2	1
55	1402-571-0-00	Tube, 12x 125	1
100	1402-002-0-00	Amplifier PCB Ass'y	1
100	1402-004-0-00	Amplifier PCB Ass'y	1
101	0034-302-0-00	Pin Terminal	9
102	0034-740-0-02	Connector-Pin, 2pin	5
103	0034-740-0-03	Connector-Pin, 3pin	2
104	0034-740-0-04	Connector-Pin, 4pin	1
105	0034-777-0-02	Connector-Pin, 2pin	1
106	0045-506-0-00	Holder-Fuse	12
107	0049-034-0-00	Heat Sink	4
108	1402-500-0-91	Amplifier PCB (N.S.P)	1
108	1402-503-0-91	Amplifier PCB (N.S.P)	1
109	1402-546-0-00	Wire-Connector, 2pin	1
110	1402-547-0-00	Wire-Connector, 4pin	1
111	1402-549-0-00	Wire-Connector, 4pin	1
112	1402-877-0-00	Support, PCB	1
113	1402-878-0-00	Heat Sink	1
114	0973-230-0-85	Screw-B Tite M3x 8	5
115	0976-530-0-85	Screw-Tap M3x 8	4
116	0976-530-1-05	Screw-Tap M3x 10	11
117	1402-520-0-00	Joiner, PCB	1
118	1402-521-0-00	Joiner, PCB	1
119	1402-522-0-00	Joiner, PCB	1
120	1402-523-0-00	Joiner, PCB	1
200	1402-020-0-00	Tuner PCB Ass'y	1
200	1402-022-0-00	Tuner PCB Ass'y	1
200	1402-021-0-00	Tuner PCB Ass'y	1
201	0034-302-0-00	Pin Terminal	6
202	0034-476-0-00	Check Pin	11
203	0034-609-0-03	Connector, 3pin	3
204	0034-609-0-05	Connector, 5pin	2
205	0034-609-0-11	Connector, 11pin	1
206	0034-740-0-02	Connector-Pin, 2pin	3
207	0049-034-0-00	Heat Sink	2
208	1402-501-0-00	Tuner PCB (N.S.P)	1
209	1402-540-0-00	Wire-Connector, 3pin	1
210	1402-541-0-00	Wire-Connector, 3pin	1
211	1402-542-0-00	Wire-Connector, 4pin	1
212	1402-543-0-00	Wire-Connector, 2pin	1
213	1402-544-0-00	Wire-Connector, 2pin	1
214	1402-545-0-00	Wire-Connector, 2pin	1
215	1402-550-0-00	Wire-Connector, 2pin	1
216	1402-551-0-00	Wire-Connector, 2pin	1
217	1402-552-0-00	Wire-Connector, 2pin	1
218	1402-879-0-00	Holder-L	1
219	0975-030-0-65	Screw-C Tite M3x 6	2
220	0976-530-0-85	Screw-Tap M3x 8	2
221	1402-528-0-00	Joiner, PCB	1
222	0045-506-0-00	Holder, Fuse	1

A, A 1

A, A 1

A, A 1

B, B 1, C, C 1

A, A 1

B, B 1, C, C 1

A, A 1

B, B 1, C

C 1

PACKING DIAGRAM

ITEM	PARTS NO.	NAME		QTY
300	1402-035-0-00	Display PCB Ass'y		1
301	1402-502-0-91	Display PCB (N.S.P)		1
302	1402-868-0-00	Frame, Display		1
303	1402-525-0-00	Joiner, PCB		1
304	1402-526-0-00	Joiner, PCB		1
305	1402-527-0-00	Joiner, PCB		1
306	1402-529-0-00	Joiner, PCB		1
400	1402-050-0-00	Speaker Terminal PCB Ass'y	A, A 1	1
400	1402-051-0-00	Speaker Terminal PCB Ass'y	B, B 1, C 1	1
400	1402-052-0-00	Speaker Terminal PCB Ass'y	C	1
401	0034-777-0-04	Connector-Pin 4pin		1
402	1402-500-0-92	Speaker Terminal PCB	A, A 1	1
402	1402-503-0-92	Speaker Terminal PCB	B, B 1, C, C 1	1
403	1402-548-0-00	Wire-Connector, 2pin		1
410	1402-055-0-00	Antenna Terminal PCB Ass'y	A, A 1	1
410	1402-056-0-00	Antenna Terminal PCB Ass'y	B, B 1, C, C 1	1
411	0034-326-0-00	Pin Terminal		8
412	1402-500-0-97	Antenna Terminal PCB	A, A 1	1
412	1402-503-0-97	Antenna Terminal PCB	B, B 1, C, C 1	1
420	1402-060-0-00	Control PCB Ass'y	A, A 1	1
420	1402-061-0-00	Control PCB Ass'y	B, B 1, C, C 1	1
421	1402-500-0-98	Control PCB	A, A 1	1
421	1402-503-0-98	Control PCB	B, B 1, C, C 1	1
422	1402-524-0-00	Joiner, PCB		1
430	1402-065-0-00	Power Switch PCB Ass'y	A, A 1	1
430	1402-066-0-00	Power Switch PCB Ass'y	B, B 1, C, C 1	1
431	0034-476-0-00	Check Pin		1
432	0034-326-0-00	Pin Terminal		3
433	0034-609-0-03	Connector, 3pin		1
434	0064-644-0-00	Cover, Spark Killer		1
435	1402-500-0-94	Power Switch PCB (N.S.P)	A, A 1	1
435	1402-503-0-94	Power Switch PCB (N.S.P)	B, B 1, C, C 1	1
436	1402-553-0-00	Wire Connector, 2pin		1
437	1402-554-0-00	Wire Connector, 2pin		1
438	1402-555-0-00	Wire Connector, 2pin		1
439	1402-500-0-96	Thermistor PCB	A, A 1	1
439	1402-503-0-96	Thermistor PCB	B, B 1, C, C 1	1
440	1402-070-0-00	Phone PCB Ass'y	A, A 1	1
440	1402-071-0-00	Phone PCB Ass'y	B, B 1, C, C 1	1
441	1402-500-0-93	Phone PCB	A, A 1	1
441	1402-503-0-93	Phone PCB	B, B 1, C, C 1	1

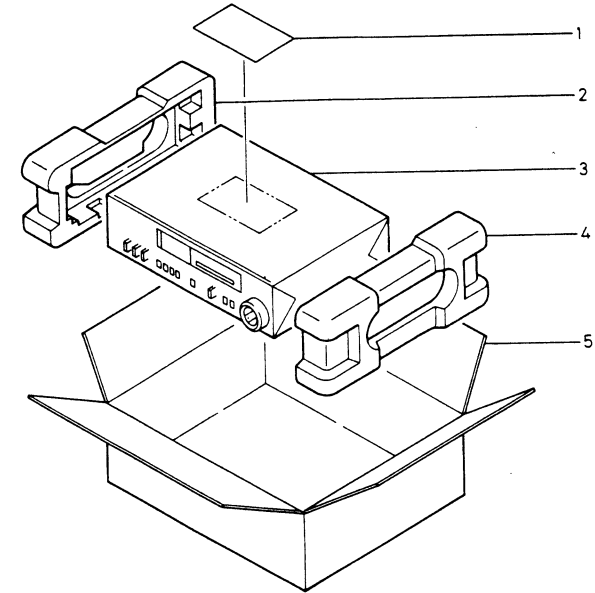

ITEM	PARTS NO.	NAME	QTY
1	1402-920-0-03	Instruction	1
2	1402-900-0-00	Styrofoam, Left	1
3	0998-013-9-00	Poly-bag, PB- 58x 55-5	1
4	1402-901-0-00	Styrofoam, Right	1
5	1402-910-0-03	Gift Box	1