

NAD **SERVICE**
MANUAL

MONITOR SERIES

7400

RECEIVER

NAD 7400 SERVICE MANUAL

CONTENTS

2. Safety Notice
3. Rear/Front View
4. Specifications
7. Main Amp, Preamp Alignment
8. Tuner Alignment
13. Schematics, Foil Diagrams
21. Wiring Diagram
23. Exploded View
24. Exploded View Parts List
27. Electrical Parts List
33. Remote Control Transmitter

Version	Voltage	Country
A	120	USA
A1	120	Canada
B	240	UK
B1	240	Australia
C	220	Europe, others
C1	220	W. Germany
C/S	220	Scandinavia

SERVICE SAFETY PRECAUTIONS (UL)

1. Use exact replacement parts for critical locations, marked "Δ" on parts list.
2. Return lead dress to original position, and re-install protective covers.
3. Before returning to customer, test for shock hazard; use either method A or B:
 - A. Leakage test, "cold":
 1. Unplug AC cord, turn power switch ON.
 2. Connect one lead of High Voltage Insulation Tester to both prongs of AC plug.
 3. Touch other lead to all exposed metal parts.
 4. Impedance measurement must be 0.3 - 5.0 Megohms.
 - B. Leakage test, "live":
 1. Plug unit directly into AC outlet; do not use isolation transformer.
 2. Connect one lead of Leakage Current Tester to earth ground.
 3. Touch other lead to all exposed metal parts.
 4. Leakage measurement must be less than 0.5 milliamps.

REAR PANEL CONNECTIONS

- | | | |
|--------------------------|--------------------------|------------------------|
| 1. AC LINE CORD. | 9. PHONO INPUT. | 17. SOFT CLIPPING. |
| 2. AC OUTLETS. | 10. MM/MC SELECTOR. | 18. BRIDGING. |
| 3. SPEAKERS A. | 11. VIDEO SOUND INPUT. | 19. SPEAKER IMPEDANCE. |
| 4. SPEAKERS B. | 12. CD INPUT. | |
| 5. AM ROD ANTENNA. | 13. TAPE 1 INPUT/OUTPUT. | |
| 6. AM ANTENNA TERMINALS. | 14. TAPE 2 INPUT/OUTPUT. | |
| 7. FM ANTENNA INPUT. | 15. PREAMP OUT, MAIN IN. | |
| 8. GROUND. | 16. INFRASONIC FILTER. | |



ATTENTION:

ET LES CONSÉQUENCES
GRAVES QUI POURRAIENT
EN RÉSULTER, NE TENEZ
PAS D'OUVERT L'APPAREIL.
ET NE TOUCHEZ AUX
COMPONENTS INTERNES
SANS LA PRÉSENCE D'UNE
PERSONNE QUALIFIÉE.

CAUTION

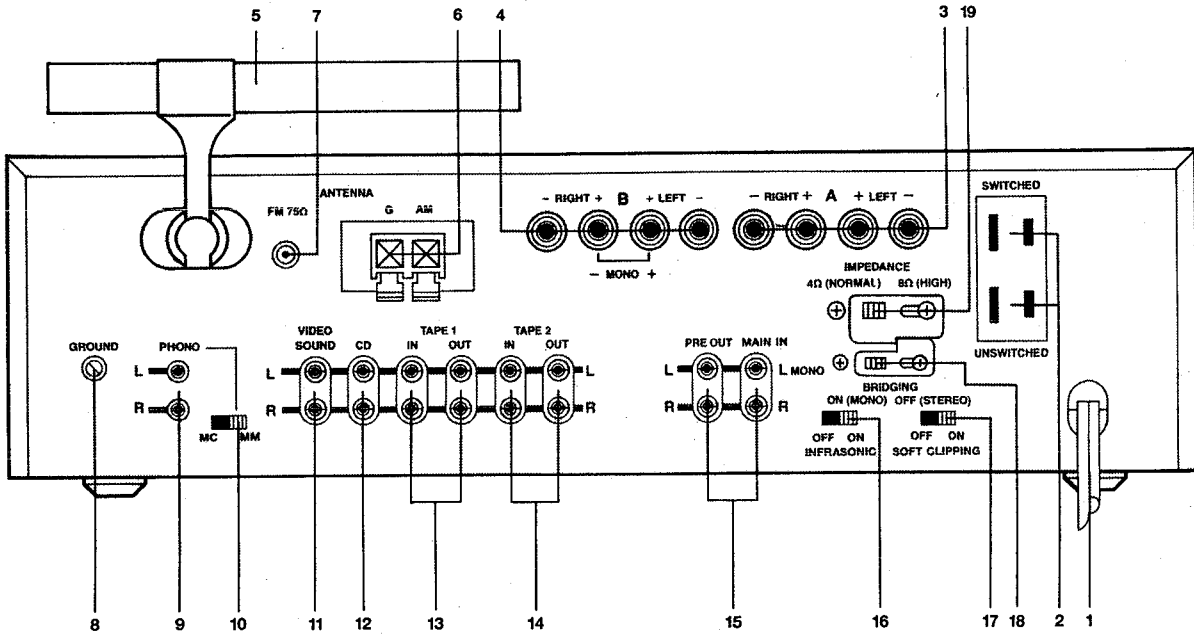
CAUTION TO REDUCE
THE RISK OF ELECTRIC
SHOCK, DO NOT REACH
COVER (OR BACK).
NO USER-SERVICEABLE
PARTS INSIDE. REFER
SERVICING TO QUALIFIED
SERVICE PERSONNEL.



 <p>The lightning flash with arrowhead, within an equilateral triangle, is intended to alert the user of the presence of uninsulated "dangerous voltage" within the product's enclosure; that may be of sufficient magnitude to constitute a risk of electric shock to persons.</p>	 <p>The exclamation point within an equilateral triangle is intended to alert the user of the presence of important operating and maintenance (servicing) instructions in the literature accompanying the appliance.</p>
--	---

FRONT PANEL CONTROLS

- | | | | |
|-------------------------|-------------------------------|----------------------|-----------------------|
| 1. POWER. | 8. TREBLE. | 15. VOLUME. | 22. FM NR OFF/MUTING. |
| 2. PHONES. | 9. TREBLE RANGE. | 16. TUNING PRE-SETS. | 23. TUNING DISPLAY. |
| 3. SPEAKERS A/B. | 10. TAPE COPY. | 17. BANK SELECTOR. | 24. TUNING KNOB. |
| 4. BASS EQ. | 11. TAPE 1, TAPE 2 (MONITOR). | 18. MEMORY ENTER. | |
| 5. BASS RANGE. | 12. INPUT SELECTOR. | 19. MONO. | |
| 6. BASS. | 13. LOW LEVEL. | 20. AM/FM SELECTOR. | |
| 7. TONE CONTROL BYPASS. | 14. BALANCE. | 21. IF NARROW. | |

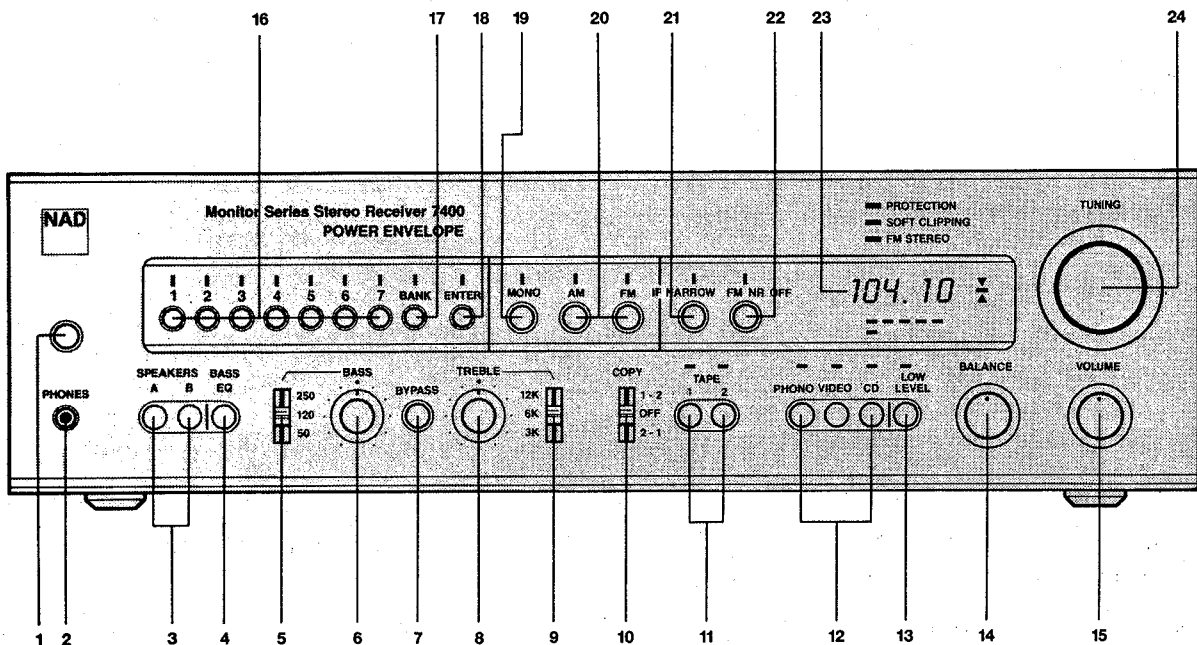

SPECIFICATIONS

Note: Specifications are measured in accordance with EIA Standard RS-490 (IHF A-202) for amplifiers and ANSI-IEEE Standard 185 (1975), i.e. IHF T-200, for tuners. Tuner sensitivity is measured via 75-ohm coaxial input. Amplifier measurements referred to 8 ohms are taken with the Speaker Impedance selector set to 8 Ω (High). Measurements for 4 and 2 ohms are taken with Impedance selector at 4 Ω (Normal).

POWER AMPLIFIER SECTION

STEREO MODE

CONTINUOUS AVERAGE POWER

OUTPUT INTO 8 OHMS

100 W (20 dBW)

(Min. RMS power per channel, 20Hz-20kHz, both channels driven, with no more than the rated distortion)

Rated distortion (THD, 20Hz-20kHz)

0.03%

Clipping power (maximum continuous power per channel)

8 ohms

130 W

IHF Dynamic Headroom at 8 ohms

+5.7 dB

IHF Dynamic Power (maximum short-term power per channel)

8 ohms

370 W (25.7 dBW)

4 ohms

400 W (26 dBW)

2 ohms

440 W (26.4 dBW)

Slew Factor

>50

Slew Rate

>30 V/ μ sec

Damping Factor (ref. 8 ohms, 50 Hz)

>100

THD (Total Harmonic Distortion, 20Hz-20kHz, from 250mW to rated output)

<0.03%

SMPTE I.M. (Intermodulation Distortion, 60Hz \pm 7kHz, 4:1, from 250mW to rated output)

<0.03%

IHF I.M. (CCIF IM Distortion, 19 \pm 20kHz at rated output)

<0.03%

Input Impedance

R = 20k Ω

C = 600 pF

Input Sensitivity for 1W out/100W out

100mV/1.0V

Voltage Gain

28 \times (29 dB)

Frequency Response

3 Hz to 100 kHz

+0, -3 dB

Signal/Noise Ratio, A weighted

98 dB ref. 1W

118 dB ref. 100W

BRIDGED (MONOPHONIC) MODE

CONTINUOUS AVERAGE POWER

OUTPUT INTO 8 OHMS

300 W (24.7 dBW)*

(Min. RMS power, 20Hz-20kHz, with no more than the rated distortion)

IHF Dynamic Headroom at 8 Ω

+4.3 dB

IHF Dynamic Power at 8 Ω (maximum short-term power)

800 W (29 dBW)

* In some countries local regulations require that bridged 8 ohm power be measured with the speaker impedance switch in the 4 ohm position resulting in a bridged RMS output of 200 W (23 dBW).

PREAMPLIFIER SECTION

PHONO INPUT

Input Impedance	MM + MC	R = 47 k Ω , C = 120 pF
Input Sensitivity (1 kHz)	1W out, MM	0.28 mV
	MC	0.02 mV
	100W out, MM	2.8 mV
	MC	0.2 mV
Input Overload at 20Hz/1kHz/20kHz	MM	20/180/1500 mV
	MC	1.5/13/110 mV
Signal/Noise ratio, IHF A- weighted, with cartridge connected	MM	76 dB ref. 5 mV
	MC	76 dB ref. 0.5 mV
THD (20Hz-20kHz) and IM Distortion at +30dB level		<0.04%
RIAA response accuracy		± 0.5 dB

LINE LEVEL INPUTS (CD, Video, Tape)

Input Impedance	R = 50 k Ω , C = 250 pF
Input Sensitivity for 1W out/100W out	15 mV/150 mV
Maximum Input Signal	10 V
Signal/Noise Ratio, A-weighted	96 dB ref. 1W out 116 dB ref. 100W out
Frequency Response,	20Hz-20kHz ± 0.3 dB

LINE LEVEL OUTPUTS

Preamp Output Impedance	600 Ω
Tape Output Impedance	1000 Ω (buffered)
Maximum Output Level	10 V (all outputs)
Tape Output Infrasonic Filter	-3 dB at 14 Hz, 12 dB/octave

CONTROLS

Treble	± 10 dB at 3, 6, or 12 kHz
Bass	± 10 dB at 50, 120, or 250 Hz
Bass Equalization	+3 dB at 60 Hz, +6 dB at 36 Hz
Infrasonic Filter (switchable)	-3 dB at 12 Hz, 12 dB/octave
Audio Muting (low level)	-20 dB

AM TUNER SECTION

Usable Sensitivity	300 μ V/meter
Selectivity	35 dB
Image Rejection	50 dB
I.F. Rejection	50 dB

S/N Ratio 45 dB
(30% mod., 50 mV input)

THD 0.5%

FM TUNER SECTION

Input Sensitivity	dBf	uV into 75Ω
Mono, -30 dB THD +N	10.3 dBf	0.9 uV
Mono, 50 dB S/N	13 dBf	1.2 uV
Stereo, 50 dB S/N		
FM NR on:	25 dBf	5 uV
FM NR off:	35 dBf	15 uV
Stereo, 60 dB S/N		
FM NR on:	35 dBf	15 uV
FM NR off:	44 dBf	45 uV
Capture Ratio		< 1.5 dB from 45 to 85 dBf
AM Rejection		> 65 dB at 45 to 85 dBf
Selectivity, alternate channel		75 dB (IF Normal) 80 dB (IF Narrow)
Selectivity, adjacent channel		7 dB (IF Normal) 20 dB (IF Narrow)
Image Rejection		> 90 dB
R.F. Intermodulation		> 65 dB
I.F. Rejection		> 100 dB
SCA Rejection		> 70 dB
Subcarrier Suppression (19 + 38 kHz)		> 60 dB
THD at 100% Modulation	1 kHz	100 Hz-6 kHz
Mono, 1 kHz	0.08%	0.2%
Stereo, 1 kHz	0.08%	0.3%
Signal-to-Noise Ratio, IHF weighted	Mono Stereo	80 dB 75 dB at 65 dBf 80 dB at 85 dBf
Frequency Response		30 Hz-15 kHz ±0.5 dB
Stereo Separation (FM NR off)		50 dB at 1 kHz 40 dB from 30 Hz to 10 kHz

PHYSICAL SPECIFICATIONS

Width × Height × Depth 43.5 × 12.1 × 40.1 cm.
(17.1 × 4.75 × 15.75 in.)

Net Weight 11.8 kg (26 lbs)

Shipping Weight 13.60 kg (30 lbs)

Power Consumption 50/60 Hz at 110, 120, 220, or 240
VAC 390 VA

Specifications are those in effect at the time of printing. NAD reserves the right to change specifications or designs at any time without notice.

MAIN AMPLIFIER ALIGNMENT

IMPORTANT NOTES

1. Before adjusting, remove input signal and load, and set speaker impedance switch to 8Ω (HIGH); reset to 4Ω (NORMAL) when finished.
2. These adjustments are always necessary after repair to main amplifier.
3. After repair, it is recommended to use current limiter (200-250W lightbulb) in mains line, for initial turn-on.

A. CENTER VOLTAGE CHECK

1. Connect DVM from Ground to R836, L chan (R886, R chan).
2. Turn power on, and check for reading of $0V \pm 100mVDC$.

B. IDLE CURRENT ADJUSTMENT

1. Connect DVM from TP801 to TP802, L chan (TP851, TP852 R chan).
2. Adjust R818, L chan (R868, R chan) for reading of $14mV \pm 1mVDC$.

C. FINAL ADJUSTMENT

1. Leave power on minimum 5 minutes.
2. Repeat center voltage check and idle current adjustment.

PREAMPLIFIER ALIGNMENT

CHANNEL BALANCE

1. Feed 1kHz, 100mV to CD input; connect AC VTVM's to Pre Out.
2. Set volume to maximum, balance to center, low level off.
3. Adjust R758 so that both channels have same output level $\pm 0.25dB$.

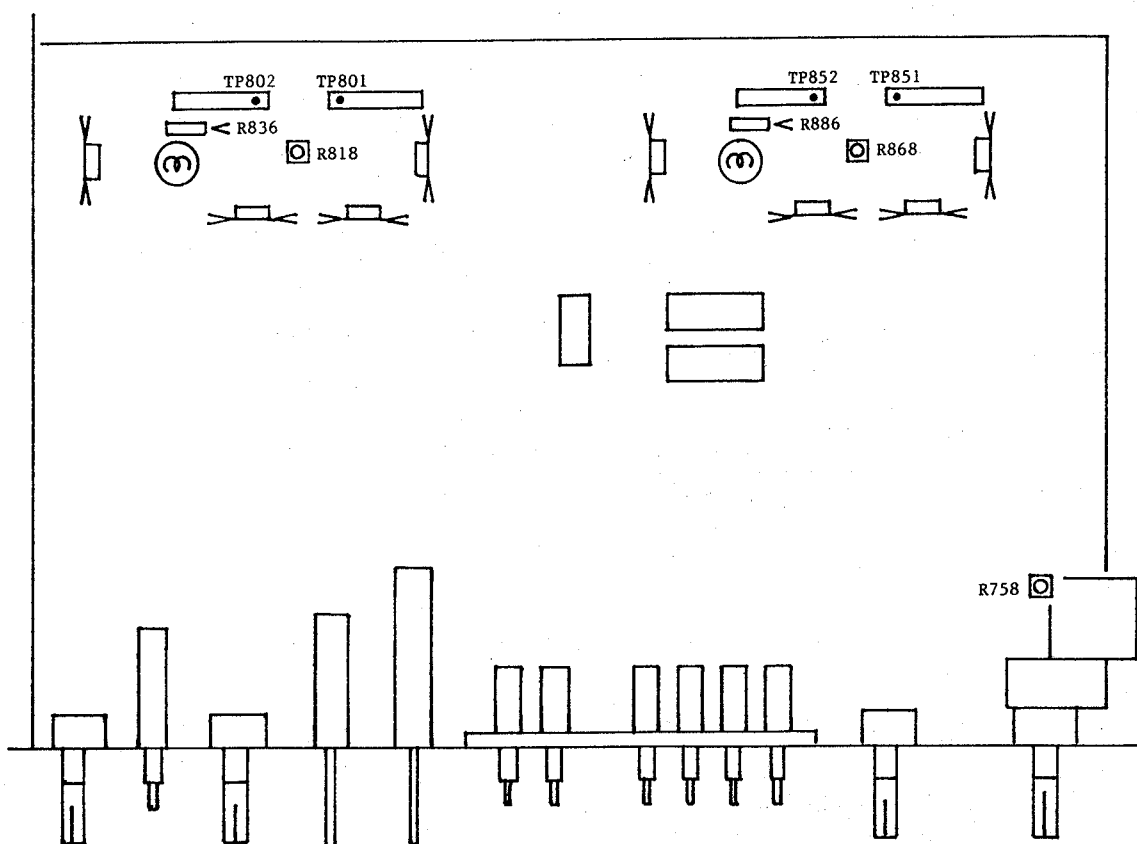

SUGGESTED INSTRUMENTATION HOOKUP – FM ALIGNMENT

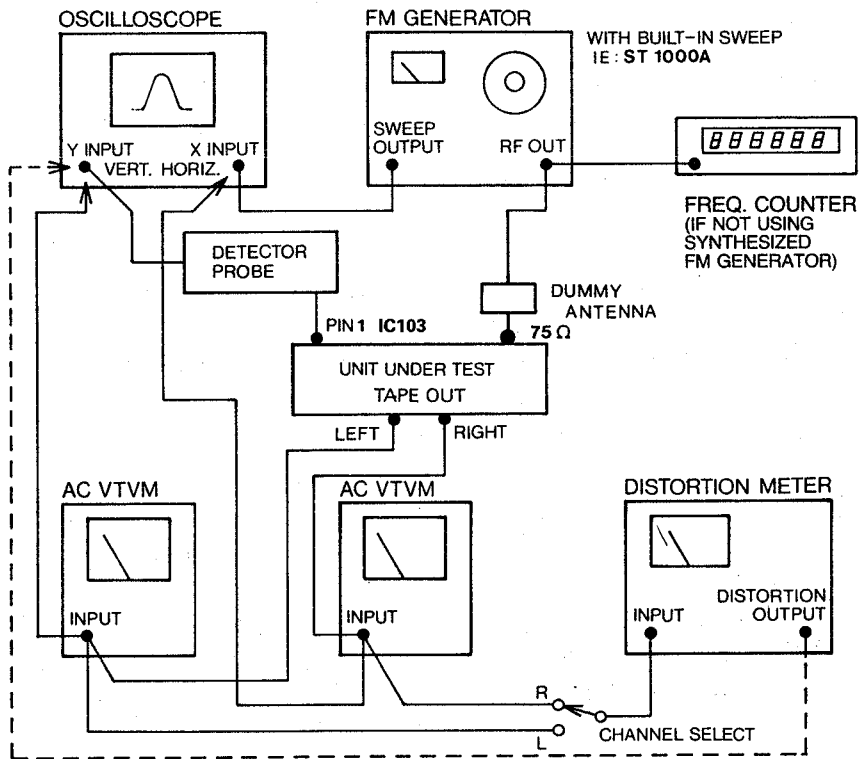
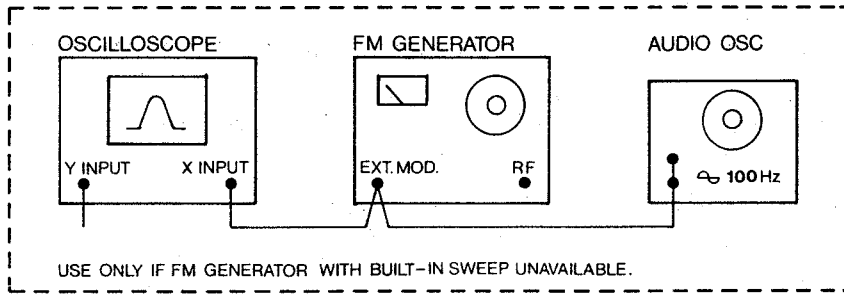

SCHEMATIC DIAGRAM OF DETECTOR PROBE

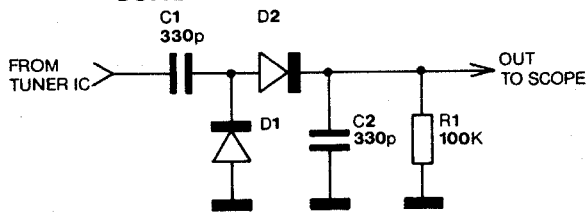

Diodes should be point-contact germanium; Some commonly available types are: OA80, OA81, AA119, 1N60, 1N34, 1N22

PICTORIAL DIAGRAM OF DETECTOR PROBE

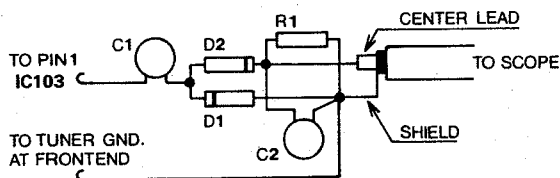

Keep leads as short as possible, to minimize stray signal pickup.

FM ALIGNMENT

NECESSARY INSTRUMENTATION

- FM Stereo Generator (THD <0.05%, Separation >50dB)
- 75Ω dummy antenna (if needed by generator)
- Audio Oscillator (not necessary if generator has built-in sweep)
- 2 AC VTVM's (or one with L/R switch)
- THD meter (resolution <0.1%)
- Oscilloscope (sensitivity 5mV or better, X/Y ability)
- Frequency Counter
- Diode Detector Probe
- DVM or DMM

IMPORTANT NOTES

- 1) RF levels are at 75Ω antenna input.
- 2) Before aligning, select FM and switch off MONO, IF NARROW, and FM NR.
- 3) If FM Generator is not synthesizer-type, check its frequency with freq. counter when adjusting detector and stereo decoder circuits.
- 4) Hum in measurements may be caused by ground loop via antenna cable; if so, use isolation balun, or isolate cable shield and hot with small capacitors (470 - 1000pf).
- 5) To adjust front-end coils, bend gently with wooden or plastic tool (non-interactive).
- 6) ENTER the following frequencies: 88.00, 90.00, 98.00, 105.00, 108.00.

A. LOCAL OSCILLATOR FREQUENCY

1. Connect Frequency Counter between TP-107 and Ground.
2. Tune to 90MHz, and adjust C278 for reading of $100.700 \pm 0.002\text{MHz}$.

B. TUNING VOLTAGE

1. Connect DVM between TP101 and Ground.
2. Tune to 88MHz, and adjust L6 for reading of $3.2 \pm 0.5\text{V}$.
3. Tune to 108MHz, and adjust L6 for reading of $22.5 \pm 1.5\text{V}$.
4. Repeat steps 2 and 3 until within tolerance.

C. TRACKING

1. Connect FM Generator to 75Ω antenna input (modulate $\pm 150\text{KHz}$ sweep, 300KHz total), and Detector Probe to Pin 1 of IC103 (ground to front-end shield.)
2. Set oscilloscope to X/Y mode, and vertical sensitivity to maximum (X, hor, is sweep signal; Y, vert, is detector probe).
3. Tune to 105MHz, and adjust generator so that curve appears on oscilloscope, and covers approximately $\frac{1}{2}$ of display.
4. Adjust C2, C10 and C12 for maximum curve height; if necessary, reduce generator output to keep entire curve on display.
5. Tune to 90MHz, and adjust generator so that curve appears on oscilloscope.
6. Adjust L2, L4, L5 for maximum curve height.
7. Repeat steps 3, 4, 5, 6 until both curves are maximum.

Note: 105MHz curve is typically slightly higher than 90MHz.

D. IF ADJUSTMENTS

1. Tune to 98MHz, and adjust generator so that curve appears on oscilloscope.
2. Adjust L8, L101 for maximum and symmetrical curve; use as little RF input as possible.
3. Remove detector probe.

E. DETECTOR ADJUSTMENT

1. Connect Tape Out to THD meter and oscilloscope.
2. Connect DVM between TP103 (-) and TP104 (+).
3. Tune to 98MHz, and feed 1000uV from generator (modulate 1KHz 100%, Mono).
4. Adjust L102 secondary (front) for minimum THD (<0.12%).
5. Adjust L102 primary (rear) for $0 \pm 0.05V$ on DVM.
6. Repeat steps, 4, 5 until no further improvement.

F. STEREO DISTORTION & SEPARATION

1. Tune to 98MHz, and feed 1000uV from generator (modulate 1KHz 100% L chan only).
2. Adjust L101, L8 just slightly for minimum THD L chan (<0.1%).
3. Adjust R375 for minimum output R chan. Next, modulate R chan and adjust R375 for minimum output L chan. If necessary, adjust R375 so that readings become same on both channels (<-46dB).
4. Select IF Narrow, and adjust R376 as in step 3 (reading <-40dB).

G. AUTO SEARCH LEVEL

1. Select IF Wide. Connect DVM between TP105 and Ground.
2. Feed 4uV from generator, and adjust R378 so that reading just goes from 0V to 4.8V.

H. SIGNAL METER LEVEL

1. Feed 5uV from generator.
2. Adjust R380 so that second LED just lights.

I. STEREO SWITCHING LEVEL

1. Feed 2uV from generator (modulate 1KHz 100% L+R).
2. Adjust R379 so that stereo LED just lights.

J. PARTIAL MUTING

1. Feed 0.5uV from generator (modulate 1KHz 30% MONO).
2. Select FM NR On. Adjust R381 full CCW.
3. Tune away from, then back to, generator frequency; and adjust R381 so that muting just turns off (sound appears).

K. FM NR; FILTERS

1. Select FM NR On. Adjust R377 full CCW.
2. Feed 1000uV from generator (modulate 1KHz 100% L+R). Set reference for S/N measurement.
3. Cancel stereo modulation, and leave pilot tone.
4. Adjust FL102 (FL103) for minimum subcarrier output on L (R) chan.
5. Reduce generator output so that S/N ratio is 50dB (approx 15uV).
6. Adjust R377 so that S/N improves to 58dB.

AM ALIGNMENT

A. TUNING VOLTAGE

1. Connect DVM between TP102 and Ground.
2. Tune to 1600(1602)kHz; Enter to preset 2. Adjust C279 for reading of $21.8 \pm 0.5V$.
3. Tune to 520(522)kHz; Enter to preset 1. Adjust L105 for reading of $1.6 \pm 0.1V$.
4. Repeat steps 2, 3 until within tolerance.

B. ANTENNA, IF

1. Swing antenna away from chassis.
2. Connect DVM between centertap R382 and Ground.
3. Tune to a station of moderate strength near 1400kHz; Enter to preset 4. Adjust C280 for maximum reading.
4. Adjust L106, L-107 for maximum reading.
5. Tune to a station of moderate strength near 600kHz; Enter to preset 3. Adjust L901(AM antenna) for maximum reading. (Use non-interactive tool, such as wood or plastic stick)
6. Repeat steps 3, 5 until no further improvement.

C. SIGNAL METER LEVEL

1. Tune to 1,000kHz, and feed 1000uV to AM Ant terminals.
2. Adjust R382 so that fifth LED just lights.

TUNER ALIGNMENT POINTS

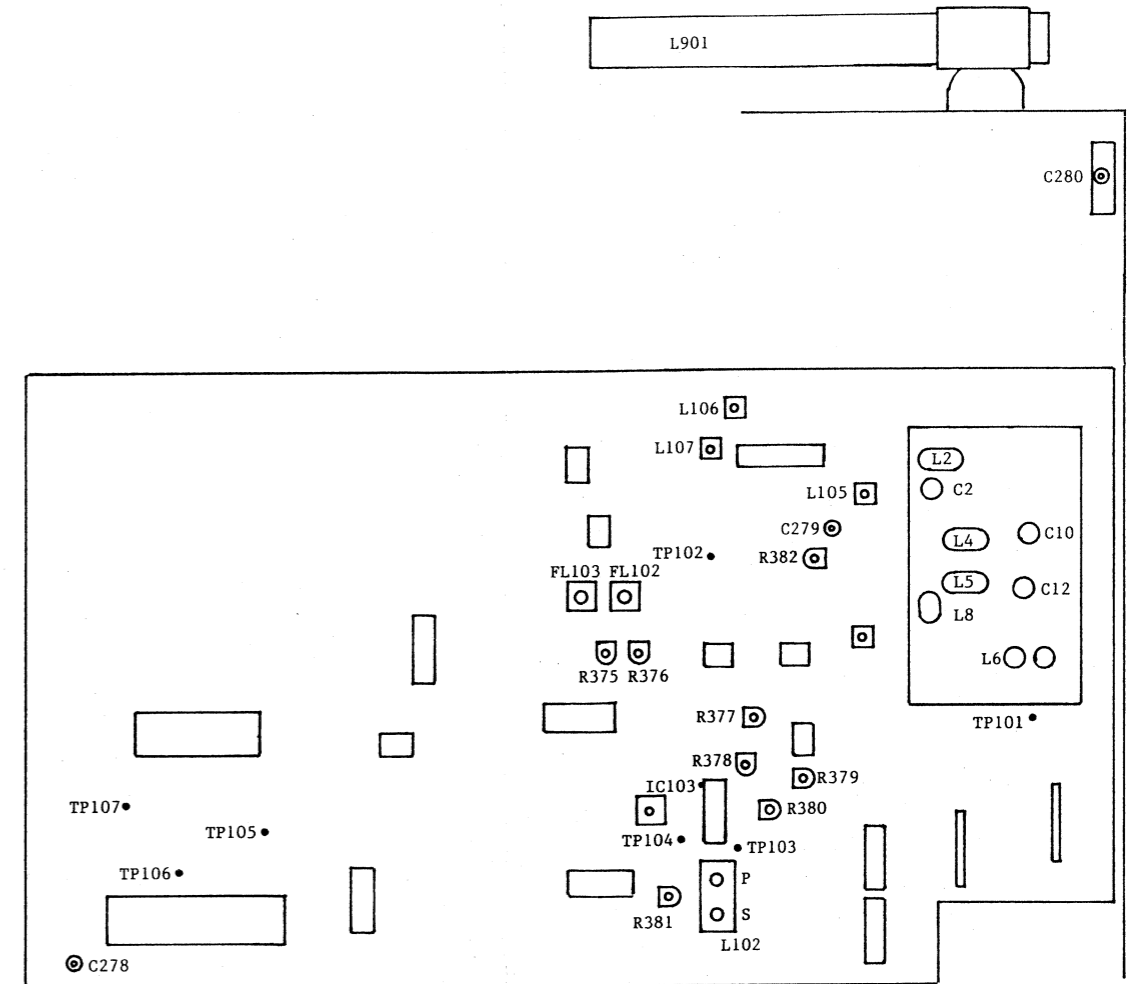

SCHEMATIC, AMPLIFIER

1) SER. 270001-270700
 R057, R051, 390
 R118, R068, 200
 R050, R051, R052, 470

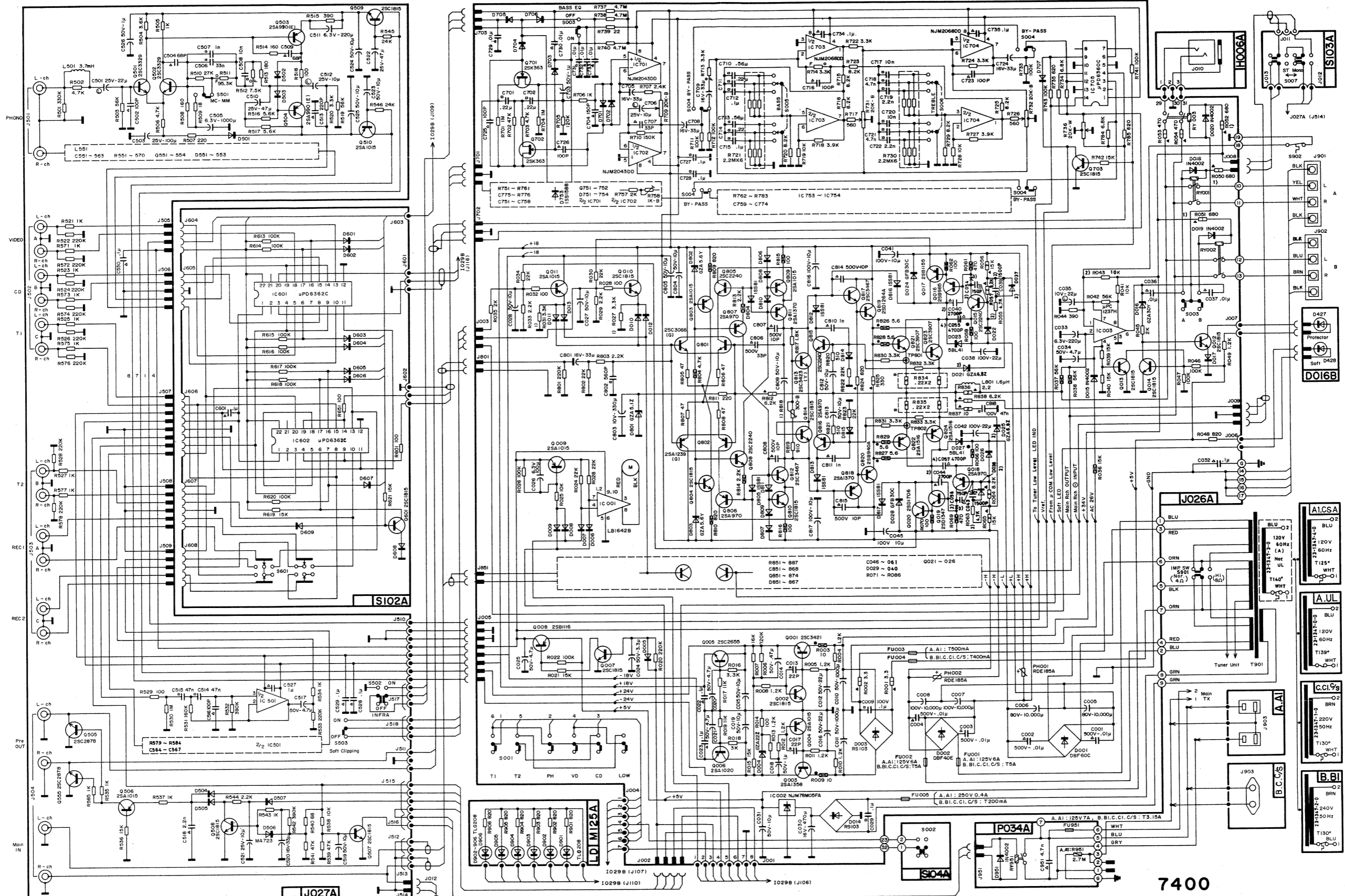

7400

2) SER. 270001-272100
 R043, 33K
 D037-040, 155178 Not used
 C054, 056, 058, 068, 150P Not used
 D021, 025, 029, 033, 62A5, 1Z

R055, 063, 071, 079, 15K
 C039, 043, 047, 051, 120P
 C040, 044, 048, 052, 470P
 3) SER. 270001-272100
 X, MARK R060, 068, 076, 084, 1K

4) SER. 270001-272100
 R059

Mark of Resistors: $\frac{1}{8}W$, $\frac{1}{4}W$, $\frac{1}{2}W$, No Mark Carbon, Metal Film, Metal Oxide Film, 1%
 Mark of Capacitors: $\frac{1}{8}W$, $\frac{1}{4}W$, $\frac{1}{2}W$, Elect Film, Cement, Elect Low Leak, No MARK Diode 155178

P.C.B. LAYOUT

INPUT/OUTPUT P.C.B. ASS'Y (J027A)

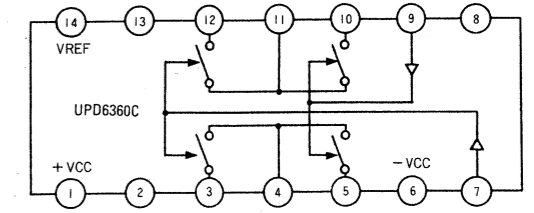
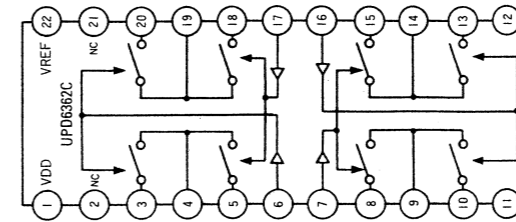
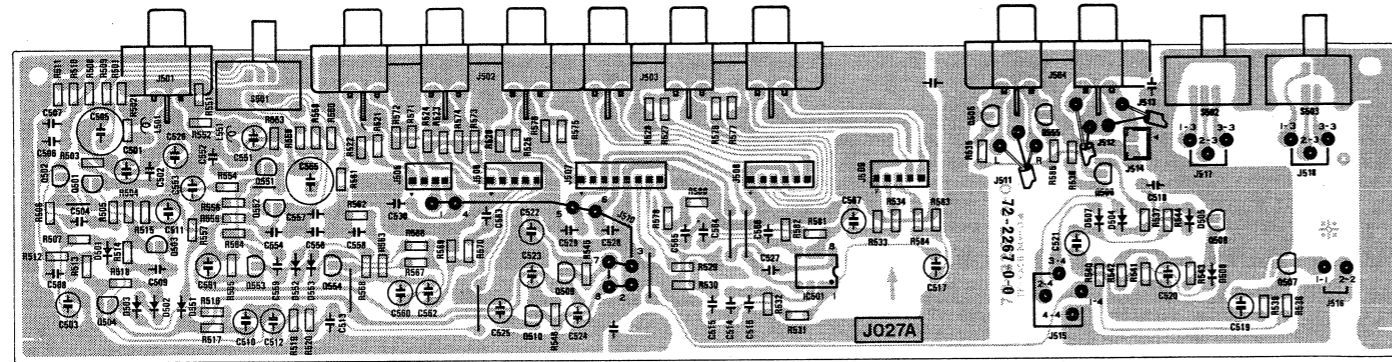

MAINS INPUT P.C.B. ASS'Y (P034A)

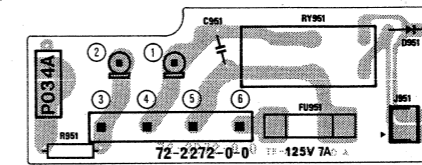

BRIDGE SWITCH ASS'Y (S103A)



MAIN/CONTROL/SUPPLY P.C.B. ASS'Y (J026A)

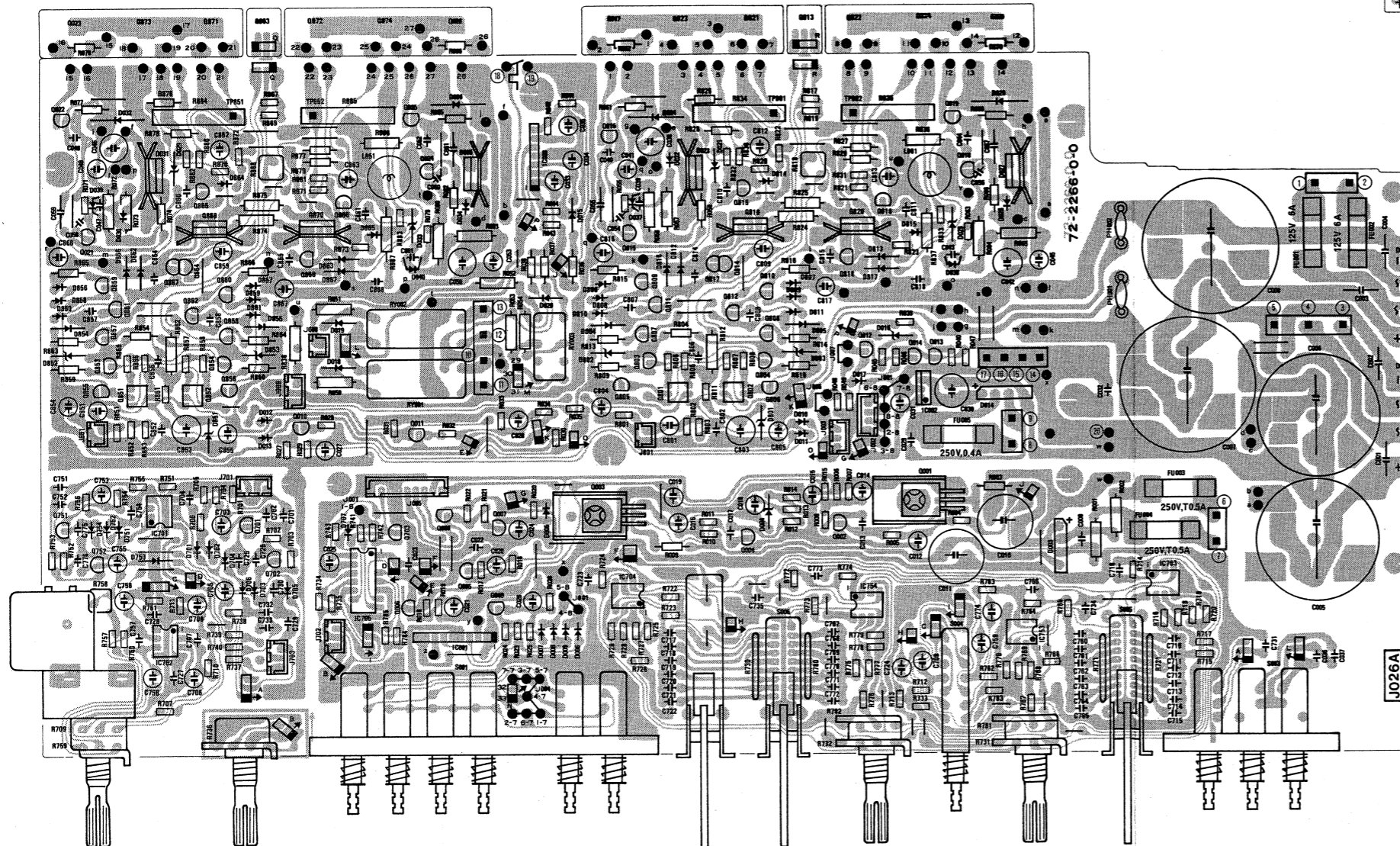

SELECTOR P.C.B. ASS'Y (S102A)

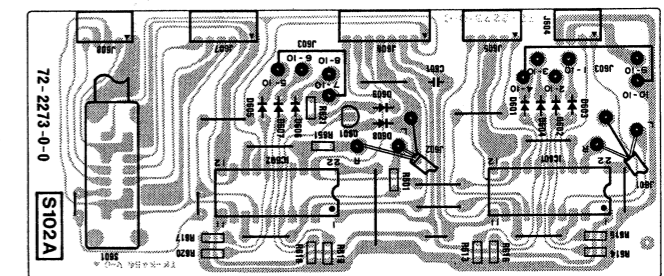

LED INDICATOR ASS'Y (M125A)

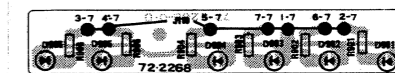

HEADPHONE CONNECTOR ASS'Y (H006A)



POWER SWITCH ASS'Y (S104A)

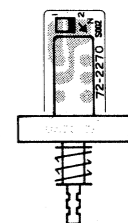

P.C.B. LAYOUT

FM FRONT-END P.C.B. ASS'Y (F017C)

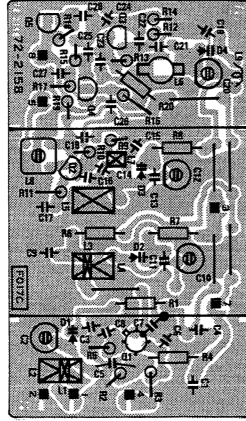

ROTARY SENSOR P.C.B. ASS'Y (N004A)

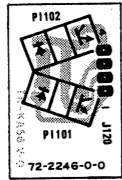

TUNER P.C.B. ASS'Y (I029B)

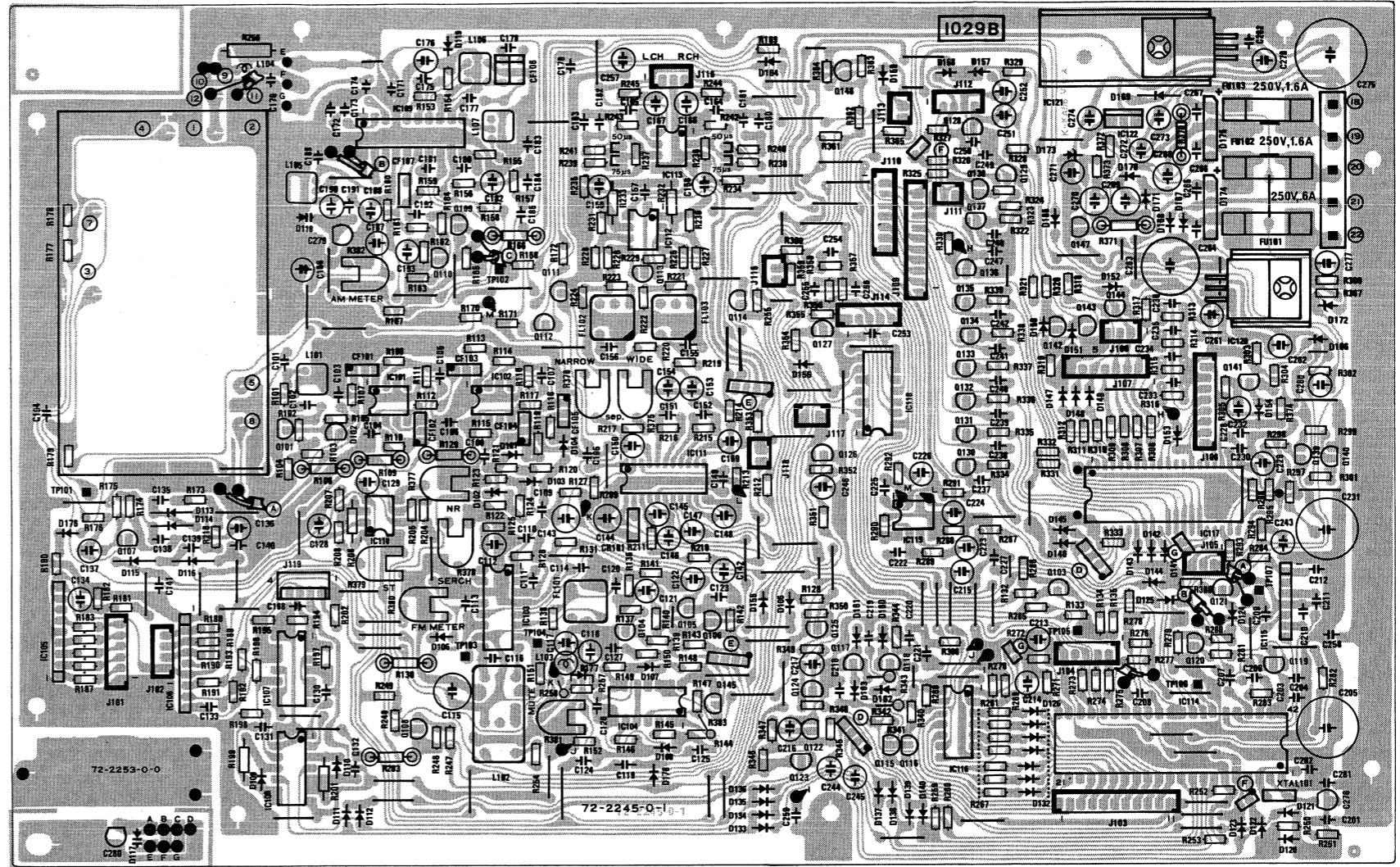

EU-type,
AM 9kHz step

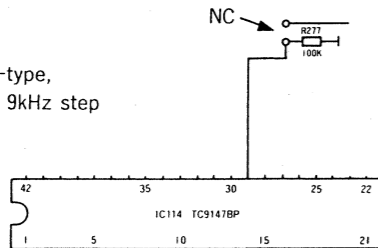

TACTILE SWITCH P.C.B. ASS'Y (S095A)

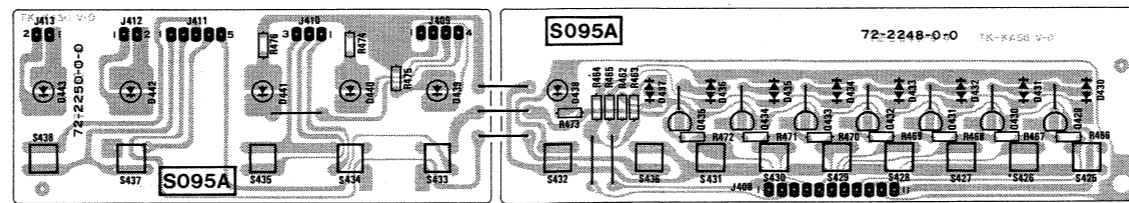

LED DISPLAY ASS'Y (D016B)

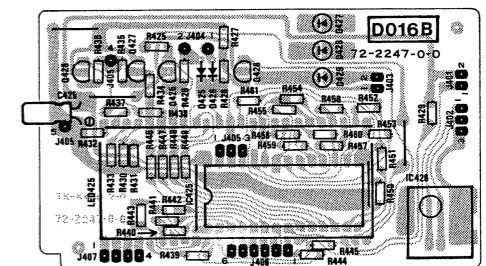

WIRING DIAGRAM

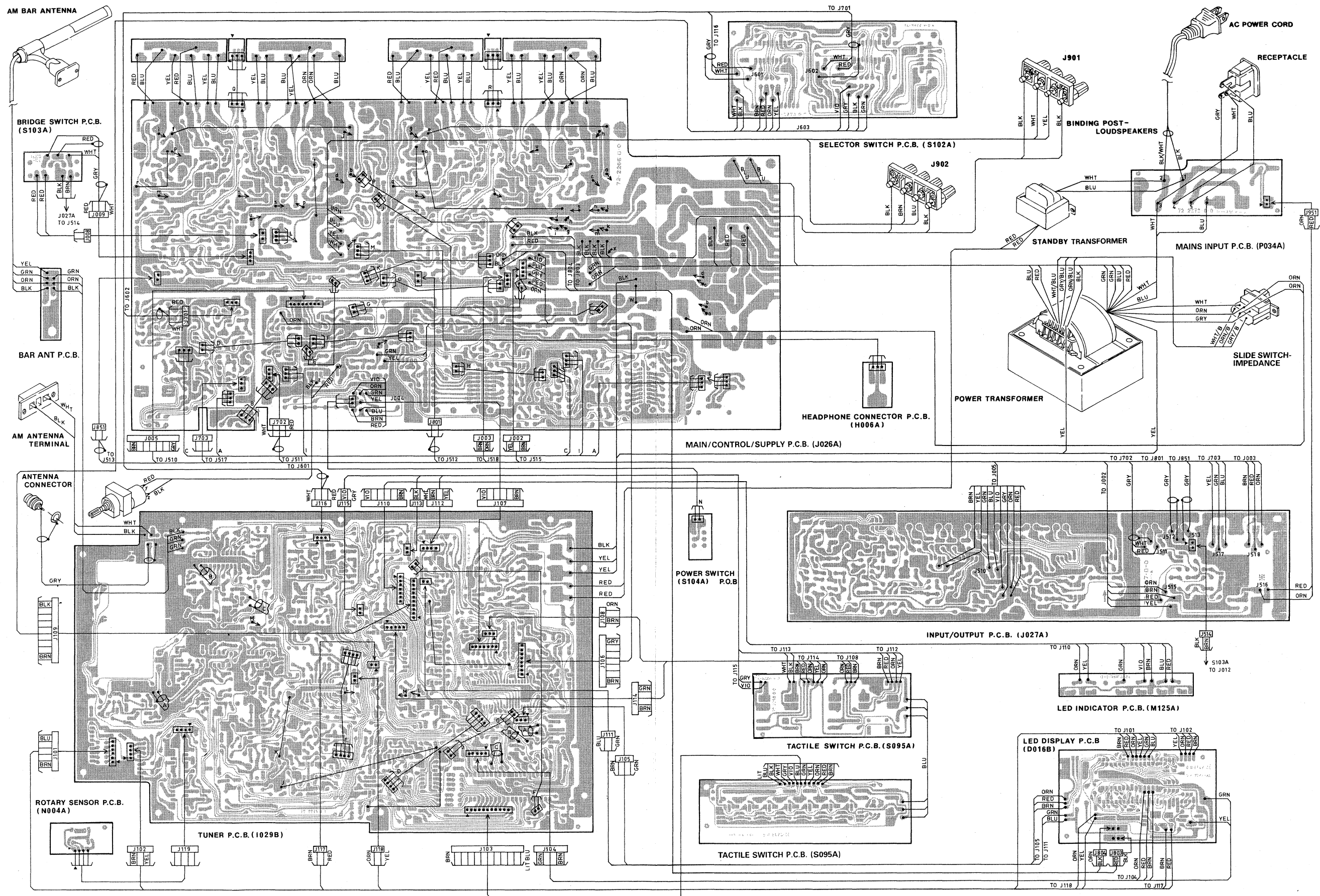

EXPLODED VIEW

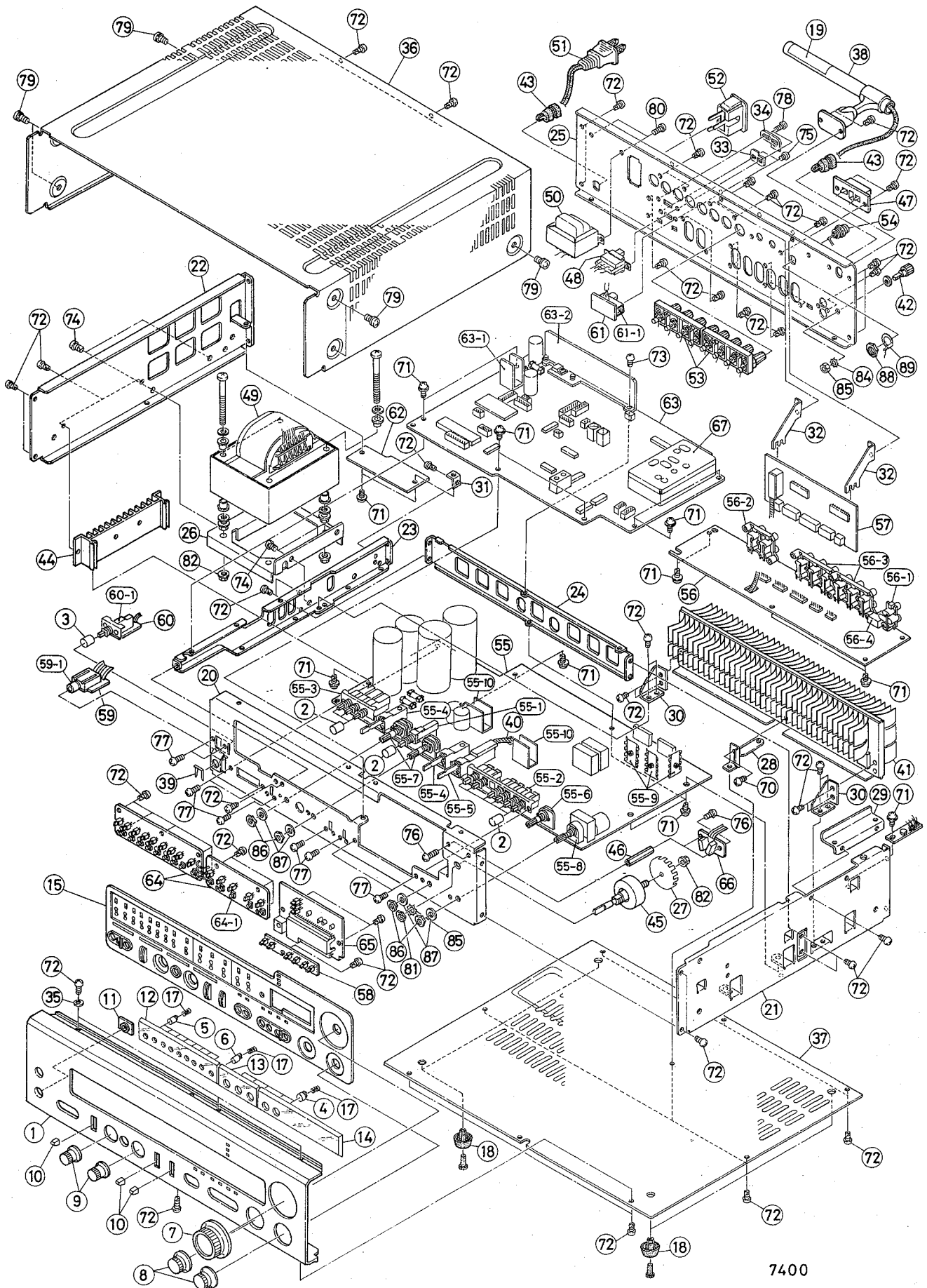

7400

EXPLODED VIEW PARTS LIST

Index No.	Parts No.	Description
1	63-6287-1-0	Front Panel
2	62-1111-0-0	Push Button(Black)-Selectors
3	62-1111-1-0	Push Button(Green)-On/Off
4	N44957-BK	Push Button(Black)-Selectors
5	N44956-BK	Push Button(Black)-Memory
6	N44988-RD	Push Button(Red)-Enter
7	62-2340-0-0	Tuning Knob
8	62-2350-0-0	Rotary Knob-Volume/Balance
9	62-2331-0-0	Rotary Knob-Tone Control
10	62-2332-0-0	Lever Knob
11	62-3480-0-0	Push Button Frame
12	63-5176-0-0	Window-I
13	63-5177-0-0	Window-II
14	63-5178-0-0	Window-III
15	62- 407-0-0	Sub Panel
17	88- 171-0-0	Spring-Push Button Return
18	92-1216-0-0	Foot
19	63-1844-0-0	Label: This is not a handle
20	71-2652-0-0	Front Chassis
21	71-2683-0-0	Side Chassis (R)
22	71-2682-0-0	Side Chassis (L)
23	71-2684-0-0	Sub Chassis-Front to Rear Support
24	71-2647-1-1	Sub Chassis-Left to Right Support
25	71-2681-0-0	Rear Panel (A,A1)
	71-2690-0-0	Rear Panel (B1)
	71-2695-0-0	Rear Panel (B,C,C1,C/S)
26	71-1966-0-0	Trans. Chassis
27	71-1912-0-0	LED Interrupter
28	71-1972-0-0	Bracket-PCB Support
29	71-1935-0-0	Wire Holder
30	71-1973-0-0	Bracket-Heatsink
31	71-1967-0-0	L Bracket-PCB Support
32	71-1971-0-0	PCB Support
33	92-1262-0-0	Lock Plate-Bridge Switch
34	92-1263-0-0	Lock Plate-Impedance Switch
35		Washer (Plain 3.5-8-0.5)
36	71-3123-0-0	Top Cover
37	71-3135-0-0	Bottom Cover
38	11-5121-0-0	AM Bar Antenna
39	HLT0999-01-480	Locking Clip-Head Phone Jack
40	81- 509-0-0	Flex Linkage, Copy SW
41	74-3124-0-0	Heatsink, Main
42	87-3242-0-0	Ground Terminal
43	62-3332-0-0	Bushing-AC Power Cord-AM BAR Antenna
44	74-3125-0-0	Heatsink, Rectifiers
45	87- 293-0-1	Tuning Shaft
46	87-3260-0-0	Hexagon Stud
47	82-2171-0-0	AM Antenna Terminal
48	81- 452-0-0	Slide Switch-Impedance Selector
49	23-1347-0-0	Power Transformer (UL)

Index No.	Parts No.	Description
49	23-1347-1-0	Power Transformer (C,C1)
	23-1347-2-0	Power Transformer (B,B1)
	23-1347-3-0	Power Transformer (A,A1)
50	23-1350-0-0	Standby Transformer (A,A1)
	23-1350-1-0	Standby Transformer (C,C1)
	23-1350-2-0	Standby Transformer (B,B1)
51	85- 267-0-0	AC Power Cord (A,A1)
	85- 235-0-0	AC Power Cord (C,C1)
	85- 240-0-0	AC Power Cord (B)
	85- 259-0-0	AC Power Cord (B1)
52	82-2207-0-0	Receptacle (A,A1)
	82-2127-0-1	Receptacle (B,C,C1)
	82-2215-0-0	Receptacle (B1)
53	86- 216-0-0	Speaker Terminal (A,A1,B,B1,C,C1)
	86- 217-0-0	Speaker Terminal (C/S)
54	82-2191-0-0	F-Type Antenna Connector (A,A1)
	82- 119-0-0	DIN Type Antenna Connector (B,B1,C,C1,C/S)
55	J026A	Main/Control/Supply Pcb Assembly
55-1	81-2351-0-0	Push Switch-Bypass
55-2	81-2353-0-0	Function Switch Bank (6 Switches)
55-3	81-2363-0-0	Function Switch Bank (3 Switches)
55-4	81- 317-0-1	Lever Switch-Turnover
55-5	81- 318-0-0	Lever Switch-Copy
55-6	41- 136-0-0	Rotary Potentiometer-Balance
55-7	41- 694-0-0	Rotary Potentiometer-Tone Control
55-8	41-8002-0-0	Rotary Potentiometer-Volume (Motor Driven)
55-9	74-3118-0-0	Heatsink, Driver
55-10	74- 388-0-0	Heatsink, Regulator
56	J027A	Input/Output Pcb Assembly
56-1	82-2130-0-0	RCA Connector (Single)
56-2	82-2157-0-0	RCA Connector (Double)
56-3	82-2159-0-0	RCA Connector (Triple)
56-4	81- 447-0-0	Slide Switch-Phono MM/MC Selector
		Slide Switch-Infrasonic ON/OFF
		Slide Switch-Soft Clipping ON/OFF
57	S012A	Selector Pcb Assembly
58	M125A	LED Indicator Assembly
59	H006A	Headphone Connector Assembly
59-1	82-2185-0-0	Headphone Jack
60	S104A	Power Switch Assembly
60-1	81-2350-0-0	Push Switch-Power ON/OFF
61	S103A	Bridge Switch Assembly
61-1	81- 463-0-0	Slide Switch-Bridge Mono/Stereo
62	P034A	Mains Input Pcb Assembly
63	I029B	Tuner Pcb Assembly
63-1	74-3111-0-0	Heatsink, Regulator, SM
63-2	74-3126-0-0	Heatsink, Regulator, LG
64	S095A	Tactile Switch Assembly
64-1	81-2345-0-0	Tactile Switch
65	D016B	LED Display Assembly
66	N004A	Rotary Sensor Assembly

Index No.	Parts No.	Description
67	F017C	Front-End Assembly
70		Tapping Screw (Philips Head 3 × 6 Cr)
71		Tapping Screw (Washer Head 3 × 6 Cr)
72		Tapping Screw (Philips Head 3 × 8 Blk)
73		Tapping Screw (Pan 3 × 8 Cr)
74		Tapping Screw (Philips Head 4 × 6 Cr)
75		Machine Screw (Philips Head 2.6 × 4 Blk)
76		Machine Screw (Philips Head 3 × 6 Cr)
77		Machine Screw (Pan 3 × 6 Cr)
78		Machine Screw (Philips Head 3 × 8 Blk)
79		Cabinet Screw with Washer (4 × 6 Blk)
80		Machine Screw S (Philips Head 3 × 6 Blk)
81		Nut (Hexagon 8-11-2 P=0.75 Cr)
82		Hexagon Flange Nut (M4 Cr)
83		Nut with Toothed Lock Washer (M4 Cr)
84		Washer (Plain 4-10-0.8 Ni)
85		Washer (Toothed Lock M8 Ni)
86		Volume Control Nut (Hexagon 7-11-2 Ni)
87		Washer (Plain 7-12-0.5 Ni)
88		Nut (Hexagon M10 Ni)
89	T5540-5	Terminal Lug

ELECTRICAL PARTS LIST

NOTE: This is not a complete electrical parts list.

1) FM FRONT-END ASSEMBLY: F017C (EXPLODED VIEW INDEX No.67)

PARTS NO.	SYMBOL NO.	DESCRIPTION
3SK 45B or 3SK 85	Q1	TRANSISTOR
2SC 535B	Q2, 4, 5.	TRANSISTOR
2SC 461B	Q3	TRANSISTOR
2SV 53F2	D1, 2, 3, 4.	DIODE (VARIABLE CAPACITOR)
11-434	L1	ANTENNA COIL, PRIMARY
11-412	L2, 4, 5.	ANTENNA COIL, SECONDARY
11-435	L3	RF COIL
12-565	L6	OSCILLATOR COIL, E520HN
15-152	L7	CHOKE COIL, VFC-15E
13-533 (or 13-535)	L8	IFT COIL, FL-6
15-166	L9	CHOKE COIL, LF-7.5 (10 μ H)
36-134	C2, 10, 12, 20.	TRIMMER CAPACITOR (3-11pF)

2) TUNER P.C.B. ASSEMBLY; 1029B (EXPLODED VIEW INDEX No.63)

PARTS NO.	SYMBOL NO.	DESCRIPTION
LA1222	IC101, 102.	IC, IF AMP
LA1235	IC103	IC, FM DET
TC4001BP	IC104	IC, MUTE LOGIC
BA6104	IC105	IC, SIG LEVEL
LB1450	IC106	IC, CTR TUNE IND
TC4011BP	IC107, 108.	IC, ROTARY TUNE
LA1247 (OR LA1245)	IC109	IC, AM
μ PC4558	IC110, 119.	IC, DUAL AMP
LA3401	IC111	IC, MPX
μ PC4570c	IC112, 113.	IC, DUAL AMP
TC9147BP	IC114	IC, SYNTH
TD6104P	IC115	IC, PRESCALE
74HC164	IC116	IC, 1/8 DECODE
μ PD7507	IC117	IC, μ COM
TC9130	IC118	IC, LATCH
78M05FA	IC120	IC, REG 5V, 0.5A
78M12FA	IC121	IC, REG 12V, 0.5A
79M12FA	IC122	IC, REG -12V, 0.5A
2SC930E	Q101, 102	TRANSISTOR
2SC1815	Q103-105, 107, 110-112. 114-116, 120-122, 124. 126-137, 140, 147.	TRANSISTOR
2SA1015	Q106, 108, 108, 119, 123. 125, 138, 139, 141-146.	TRANSISTOR
2SK30	Q113	TRANSISTOR
2SK246	Q117, 118.	TRANSISTOR
1SS214	D101-104.	DIODE
1S188FM	D113-116.	DIODE
KV1226V	D117, 118.	DIODE
1SS178 (or SR-1M-2)	D167, 168, 170, 171.	DIODE
SR-1M-2	D169	DIODE
GZS7.5Y	D172	ZENER DIODE

PARTS NO.	SYMBOL NO.	DESCRIPTION
GAS36R (or GZA36X)	D173	ZENER DIODE
DBA10B	D174, 175.	DIODE
1SS176	OTHERS	DIODE
13-533	L101	IFT COIL
13-536-1	L102	IFT COIL
14-310	L103	CHOKE COIL (5.6mH)
15-167	L104	CHOKE COIL (120 μ H)
12-564	L105	OSCILLATOR COIL
13-348	L106	IFT COIL
13-347	L107	IFT COIL
5.5V, 0.047F	C205, 231.	MEMORY BACK-UP CAPACITOR
50V, 1 μ F	C117, 146, 257.	ELECT. CAPACITOR, LOW LEAKAGE
50V, 0.47 μ F	C145	ELECT. CAPACITOR, LOW LEAKAGE
50V, 0.33 μ F	C223	ELECT. CAPACITOR, LOW LEAKAGE
50V, 0.22 μ F	C226, 246.	ELECT. CAPACITOR, LOW LEAKAGE
25V, 4.7 μ F	C277	ELECT. CAPACITOR, LOW LEAKAGE
36-136	C278	TRIMMER CAPACITOR (5.2-30pF)
36-134	C279	TRIMMER CAPACITOR (3-11pF)
36-133	C280	TRIMMER CAPACITOR (2-7pF)
68 Ω .1/4W	R370	FUSIBLE RESISTOR
41-789	R375, R378, 380.	VARIABLE RESISTOR (20K Ω)
41-792	R376	VARIABLE RESISTOR (100K Ω)
41-787	R377	VARIABLE RESISTOR (5K Ω)
41-788	R379	VARIABLE RESISTOR (10K Ω)
41-796	R381	VARIABLE RESISTOR (1M Ω)
41-791	R382	VARIABLE RESISTOR (50K Ω)
SFE10.7MLK	CF101-103.	CERAMIC FILTER
SFE10.7MZ2	CF104, 105.	CERAMIC FILTER
SFZ450F	CF106	CERAMIC FILTER
BFU450C	CF107	CERAMIC FILTER
19-146	FL101	ANTI-BIRDIE FILTER
19-158	FL102, 103.	MPX FILTER
CSB456F11	CR101	CERAMIC RESONATOR
19-205	XTAL101	CRYSTAL RESONATOR (7.2MHz)
△ 5TT600	FU101 (A, A1)	FUSE (250V, 600mA)
5ST630	" (B, B1, C, C1, C/S)	FUSE (250V, T630mA)
△ 5TT1.6	FU102, 103. (A, A1)	FUSE (250V, 1.6A)
5ST1.6	" , " (B, B1, C, C1, C/S)	FUSE (250V, T1.6A)

3) ROTARY SENSOR ASSEMBLY; N004A (EXPLODED VIEW INDEX No.66)

PARTS NO.	SYMBOL NO.	DESCRIPTION
TLP801A	P101,102.	PHOTO INTERRUPTOR

4) LED DISPLAY ASSEMBLY; D016B (EXPLODED VIEW INDEX No.65)

PARTS NO.	SYMBOL NO.	DESCRIPTION
TD6301AP	IC425	IC, DISPLAY DECODE
SBX1483-51	IC426	IR RECEIVER
2SC1815	Q425, 427.	TRANSISTOR
2SC2500	Q426	TRANSISTOR
2SA1015	Q428	TRANSISTOR
1SS176	D425, 426.	DIODE
TLR208	D427	LED (RED)
TLO208	D428, 429.	LED (ORANGE)
SL-5653-01	LED425	LED DISPLAY

5) TACTILE SWITCH ASSEMBLY; S095A (EXPLODED VIEW INDEX No.64)

PARTS NO.	SYMBOL NO.	DESCRIPTION
2SC1815	Q429-435.	TRANSISTOR
TLOG208	D430-437.	LED (ORANGE/GREEN)
TLR208	D438	LED (RED)
TLG208	D439-441.	LED (GREEN)
TLO208	D442, 443.	LED (ORANGE)
81-2345	S425-438	TACTILE SWITCH

6) LED INDICATOR ASSEMBLY; M125A (EXPLODED VIEW INDEX No.58)

PARTS NO.	SYMBOL NO.	DESCRIPTION
TLO208	D901	LED (ORANGE)
TLG208	D902-906.	LED (GREEN)

7) MAIN/CONTROL/SUPPLY PCB ASSEMBLY; J026A (EXPLODED VIEW INDEX No.55)

PARTS NO.	SYMBOL NO.	DESCRIPTION
LB1642B	IC001	IC, MOTOR DRIVE
NJM78M05FA	IC002	IC, REG 5V, 0.5A
μ PC1237H or HA	IC003	IC, PROTECT
NJM2043DD	IC701, 702.	IC, DUAL AMP
NJM2068DD	IC703, 704, 753, 754.	IC, DUAL AMP
μ PD6360C	IC705	IC, FET SW
2SC3421	Q001	TRANSISTOR
2SC1815	Q002, 007, 010, 012-014, 703, 804, 810, 814, 854, 860, 864.	TRANSISTOR
2SA1358	Q003	TRANSISTOR
2SA1015	Q004, 009, 011, 803, 809, 853, 859.	TRANSISTOR
2SC2655	Q005	TRANSISTOR
2SA1020	Q006	TRANSISTOR
2SB1116	Q008	TRANSISTOR
2SC2240	Q015, 021, 805, 808, 815, 855, 858, 865.	TRANSISTOR
2SB985	Q016, 022.	TRANSISTOR
2SA970	Q018, 024, 806, 807, 816, 856, 857, 866.	TRANSISTOR

PARTS NO.	SYMBOL NO.	DESCRIPTION
2SD1347	Q019, 025.	TRANSISTOR
2SK363	Q701, 702, 751, 752.	TRANSISTOR
2SC3066	Q801, 851.	TRANSISTOR
2SA1239	Q802, 852.	TRANSISTOR
2SA1370	Q811, 818, 861, 868.	TRANSISTOR
2SC3467	Q812, 817, 862, 867.	TRANSISTOR
2SD1264	Q819, 869.	TRANSISTOR
2SB940	Q820, 870.	TRANSISTOR
RS103	D003, 014.	DIODE
GZA22Z	D004	ZENER DIODE
1N4002	D015, 018-020.	DIODE
GZA30Y	D016	ZENER DIODE
GZA6.8Z	D021, 025, 029, 033.	ZENER DIODE
5BL41	D023, 027, 031, 035.	DIODE
GFB30C	D024, 028, 032, 036.	DIODE
1S1588	D753	DIODE
GZA5.1Z	D801, 851.	ZENER DIODE
GZA5.6Y	D802, 803, 852, 853.	ZENER DIODE
1SS81	D804, 805, 812, 813, 816, 807, 854, 855, 862, 863, 866, 867.	DIODE
1SS178	OTHERS	DIODE
15-147	L801, 851.	CHOKE COIL (1.6 μ H)
△ 80V, 10000 μ F	C005, 006.	ELECT. CAPACITOR, LGS-4
△ 100V, 10000 μ F	C007, 008.	ELECT. CAPACITOR, LGS-4
10V, 22 μ F	C035	ELECT. CAPACITOR, LOW LEAKAGE
35V, 10 μ F	C706, 756.	ELECT. CAPACITOR, LOW LEAKAGE
3.3 Ω , 1W	R001, 002.	OXIDE METAL RESISTOR (RS1FS)
△ 10 Ω , 1/4W	R003, 009.	FUSIBLE RESISTOR (ERD2FC)
680 Ω , 1W	R050, 051, 052.	OXIDE METAL RESISTOR (RS1FSM)
470 Ω , 1W	R053, 054.	OXIDE METAL RESISTOR (RS1FSM)
15K Ω , 2W	R056, 065, 072, 081.	OXIDE METAL RESISTOR (RS2FSM)
8.2K Ω , 2W	R057, 064, 073, 080.	OXIDE METAL RESISTOR (RS2FSM)
3.3K Ω , 1/6W	R713, 714, 763, 764.	METAL FILM RESISTOR (RNK1/6TA21)
2.2M Ω , 1/8W	R721, 730, 771, 780.	RESISTOR ARRAY (RRS1/8 8M)
△ 5.6 Ω , 1/4W	R826-829, 876-879.	FUSIBLE RESISTOR (ERD2FC)
100 Ω , 1/4W	R058, 066, 074, 082.	FUSIBLE RESISTOR (ERD2FCG)
41-7110	R758	VARIABLE RESISTOR (EVN-D4A, 1K Ω)
41-7116	R818, 868.	VARIABLE RESISTOR (EVN-D4A, 300 Ω)
6.2K Ω , 1W	R812, 838, 862.	OXIDE METAL RESISTOR (RS1FSM)
820 Ω , 1W	R824, 874.	OXIDE METAL RESISTOR (RS1FSM)
330 Ω , 1W	R825, 875.	OXIDE METAL RESISTOR (RS1FSM)
0.22+0.22 Ω	R834, 835, 884, 885.	CEMENTED RESISTOR (MPC725)
2.2 Ω , 2W	R836, 886.	OXIDE METAL RESISTOR (RS2FSM)
10 Ω , 2W	R837, 887.	OXIDE METAL RESISTOR (RS2FSM)
△ 81-622-1-0	RY001, 002.	RELAY, MR72, SPEAKER
△ 81-628-0-0	RY003	RELAY, MR62SR, PHONES
△ RDE185A	PH001, 002.	P.T.C. (POLYSWITCH)
△ 81-7011-0-0	18-19	THERMOSTAT (90°C), UP-62

PARTS NO.	SYMBOL NO.	DESCRIPTION
△ 5MF6	FU001, 002. (A, A1)	FUSE (125V, 6A)
EAK5	" , " (B, B1, C, C1, C/S)	FUSE (250V, T5A)
△ 5TT500	FU003, 004. (A, A1)	FUSE (250V, 0.5A)
EAWK400mA	" , " (B, B1, C, C1, C/S)	FUSE (250V, T400mA)
△ 5MF400	FU005 (A,A1)	FUSE (250V, 400mA)
EAWK200	" (B,B1,C,C1,C/S)	FUSE (250V, T200mA)

8) INPUT/OUTPUT PCB ASSEMBLY; J027A (EXPLODED VIEW INDEX No.56)

PARTS NO.	SYMBOL NO.	DESCRIPTION
NJM2068DD	IC501	IC, DUAL AMP
2SC3329	Q501, 502, 551, 552.	TRANSISTOR
2SA990	Q503, 504, 553, 554.	TRANSISTOR
2SC2878	Q505, 555.	TRANSISTOR
2SA1015	Q506, 510.	TRANSISTOR
2SC1815	Q507-509.	TRANSISTOR
1SS178	D501-505, 507, 551-553.	DIODE
MA723	D506	DIODE
15-168	L501, 551.	CHOKE COIL (3.7mH)
16V, 22 μ F	C501, 551.	ELECT. CAPACITOR, LOW LEAKAGE
25V, 10 μ F	C512, 562.	ELECT. CAPACITOR, LOW LEAKAGE
95.2K Ω , 1/6W	R511, 561.	OXIDE METAL RESISTOR (RNK1/6TA21)
7.5K Ω , 1/6W	R512, 562.	OXIDE METAL RESISTOR (RNK1/6TA21)

9) SELECTOR PCB ASSEMBLY; S102A (EXPLODED VIEW INDEX No.57)

PARTS NO.	SYMBOL NO.	DESCRIPTION
μ PC6362C	IC601, 602.	IC, FET SW
2SC1815	Q601	TRANSISTOR
1SS178	D601-609.	DIODE

10) MAINS INPUT PCB ASSEMBLY; P034A (EXPLODED VIEW INDEX No.62)

PARTS NO.	SYMBOL NO.	DESCRIPTION
1N4002	D951	DIODE
△ ECK-DNS472ZV(4700p)	C951 (A, A1)	CERAMIC CAPACITOR
ECK-DNS472MEX(4700p)	" (B, B1, C, C1, C/S)	CERAMIC CAPACITOR
△ 2.7M Ω , 1/2W	R951 (A,A1)	CARBON RESISTOR (PNS1/2)
△ 5MF7	FU951 (A, A1)	FUSE (125V, 7A)
EAK3.15	" (B, B1, C, C1, C/S)	FUSE (250V, T3.15A)
△ 81-625-0-0	RY951	RELAY, VS-12MB-NR, POWER

11) CHASSIS-MOUNTED COMPONENTS: 24721

PARTS NO.	SYMBOL NO.	DESCRIPTION
△ 2SB1155	Q017, 023.	TRANSISTOR
△ 2SD1706	Q020, 026.	TRANSISTOR
△ 2SC3423	Q813, 863.	TRANSISTOR
△ 2SC3907	Q821, 823, 871, 873.	TRANSISTOR
△ 2SA1516	Q822, 824, 872, 874.	TRANSISTOR
△ DBF60C	D001	DIODE
△ DBF40E	D002	DIODE

REMOTE CONTROL TRANSMITTER

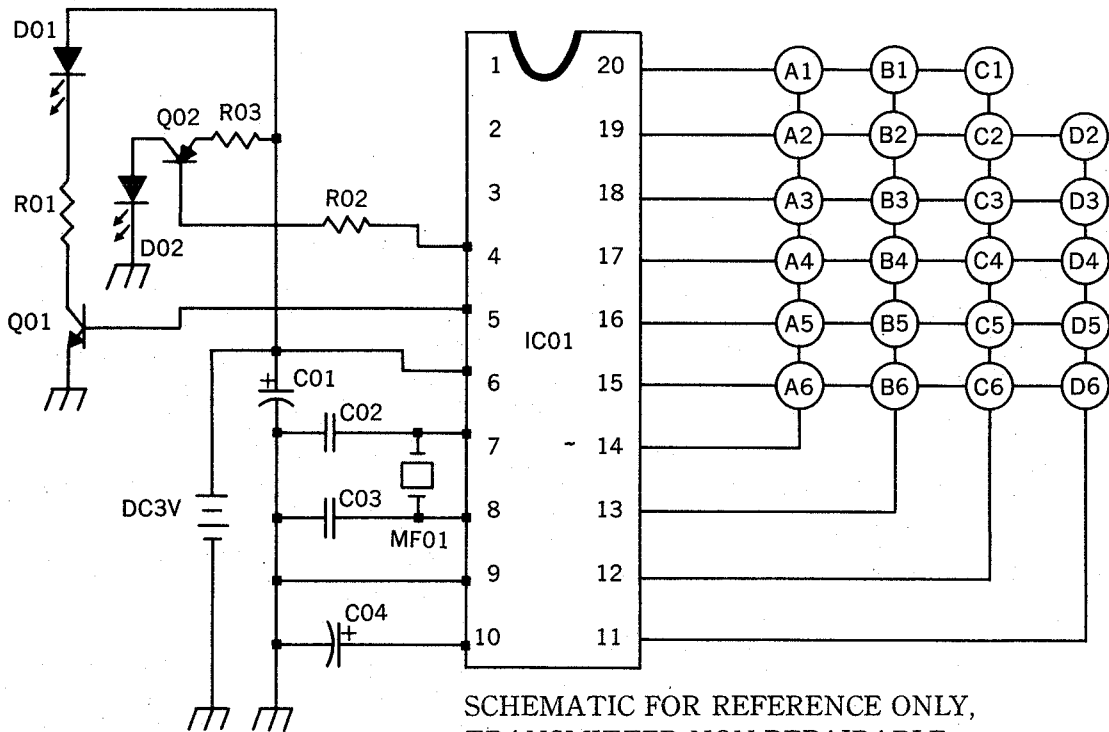
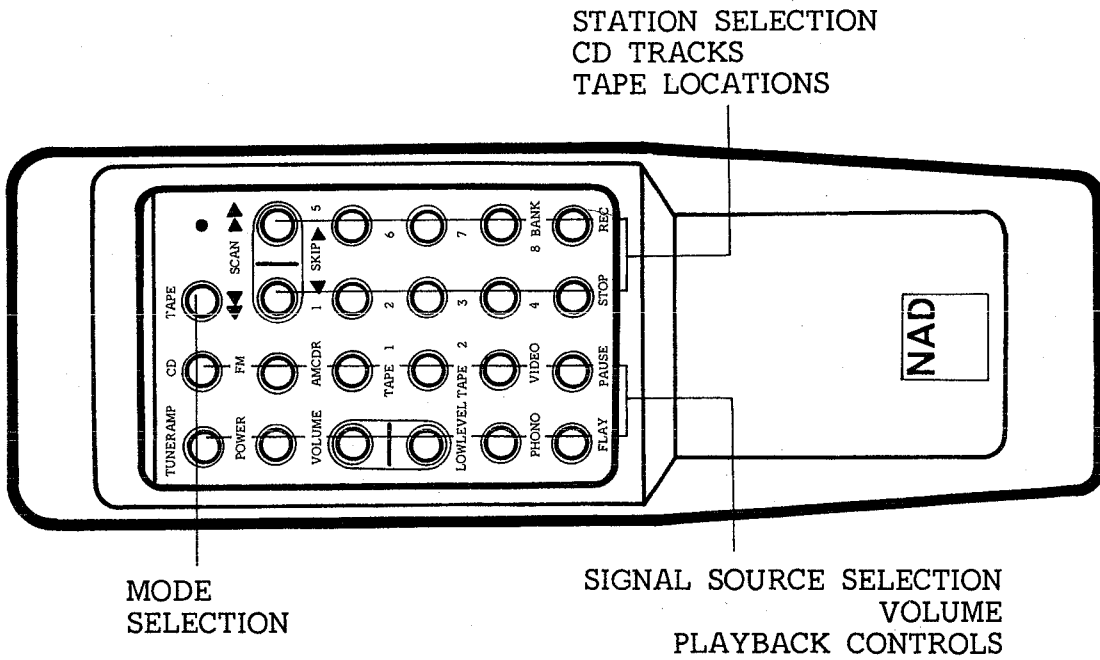

SCHEMATIC FOR REFERENCE ONLY,
TRANSMITTER NON-REPAIRABLE.