

SERVICE MANUAL



910

AV SURROUND
SOUND
PROCESSOR

910

AV SURROUND
SOUND
PROCESSOR



TABLE OF CONTENTS

Specifications	3
Front Panel	5
Rear Panel	5
Alignment Procedure	5
Wiring Diagram	6
Schematic Diagrams	7
PCB Layouts	10
IC Block Diagrams	12
Exploded View	14
Exploded View Parts List	15
Electrical Parts List	16
Packing Diagram	19

SERVICE SAFETY PRECAUTIONS

1. Replacing the fuses

CAUTION: FOR CONTINUED PROTECTION AGAINST THE RISK OF FIRE, REPLACE ONLY WITH SAME TYPE OF FUSE.

Reference No.	Part Number	Description
F001*AH	595G0012F	1A/250V fast blow, glass (UL/CSA)
F001*C	595G00123F	F1AL/250V (SEMKO/VDE)
F002*AH	595G0012F	1A/250V fast blow, glass (UL/CSA)
F002*C	595G00123F	F1AL/250V (SEMKO/VDE)

Note:

- *AH : U.S.A., Canadian model only.
- *C : European model only.

2. Safety-check out (U.S.A model only)

Parts marked with the symbol  are critical with regard to the risk of fire and electric shock. Replace only with parts recommended by the manufacturer.

Before returning the product to the customer, make leakage current or resistance measurements to determine that exposed parts are acceptably insulated from the supply circuit.

SPECIFICATIONS

LEVELS:

	FRONT	CENTER	REAR
Dolby	300mV	220mV	215mV
Club	280mV	-	-
Hall	310mV	220mV	200mV
Stadium	290mV	-	180mV
AV Stereo	310mV	-	-

FREQUENCY RESPONSE:

	FRONT	CENTER	REAR
Dolby (+0 -3dB)	12Hz-45kHz	220Hz-22kHz	30Hz-6.5kHz
Club (+0 -3dB)	78Hz-1.6kHz	-	-
Hall (+0 -3dB)	12Hz-45kHz	220Hz-22kHz	30Hz-6.5kHz
Stadium (+0 -3dB)	200Hz-42kHz	-	30Hz-6.5kHz
AV Stereo (+0 -3dB)	12Hz-50kHz	-	-

HUM AND NOISE (Input Shorted, DIN Audio/IHF A)

	FRONT	CENTER	REAR
Dolby	75/80dB	75/80dB	61/67dB
Club	78/83dB	-	-
Hall	75/80dB	75/80dB	61/67dB
Stadium	75/81dB	-	57/64dB
AV Stereo	76/81dB	-	-

HARMONIC DISTORTION: (Input 1kHz; Output 1V; 80kHz Filter ON)

	FRONT	CENTER	REAR
Dolby	0.06%	0.1%	0.6%
Club	0.04%	-	-
Hall	0.06%	0.1%	0.6%
Stadium	0.04%	-	0.6%
AV Stereo	0.04%	-	-

OVERLOAD: (Input 1kHz; Output 1V; Distortion 1%)

	FRONT	CENTER	REAR
Dolby	2.8V	1.75V	1.5V
Club	4V	-	-
Hall	2.8V	1.75V	1.5V
Stadium	4V	-	1.5V
AV Stereo	4V	-	-

RESIDUAL NOISE: (DIN Audio/IHF A)

	FRONT	CENTER	REAR
	12uV	40uV	25uV

CHANNEL SEPARATION:

	FRONT	CENTER	REAR
Dolby - L or R	-36dB	-46dB	-40dB
Center	-35dB	-	-35dB
Rear	-45dB	-32dB	-
Club - L or R	-18dB	-	-
Stadium	-17dB	-	-
AV Stereo	-65dB	-	-

SUB WOOFER:

Sensitivity (Output 1V, 80Hz)	FRONT	CENTER	REAR
	380mV	190mV	

Frequency Response 120Hz (-3dB)

SIBILANCE FILTER (Input 6.5kHz)..... -2dB

CDR (Input 1kHz -15dBv)..... +5dB

PEAK OVERLOAD SENSITIVITY..... 3V

VIDEO SECTION:

Sensitivity (Output Level 1V, 75 Ohm Load).....	1V
Frequency Response.....	10Hz-10MHz -1dB
Overload	1.4V
Signal to Noise Ratio.....	120dB

GENERAL:

Power Consumption.....	15W
Dimensions.....	435(W)x86(H)x302(D)mm
Weight.....	4.3kg/9.48lbs.

WARNING: TO PREVENT FIRE OR ELECTRIC SHOCK, DO NOT EXPOSE THIS APPLIANCE TO RAIN OR MOISTURE.

FRONT PANEL

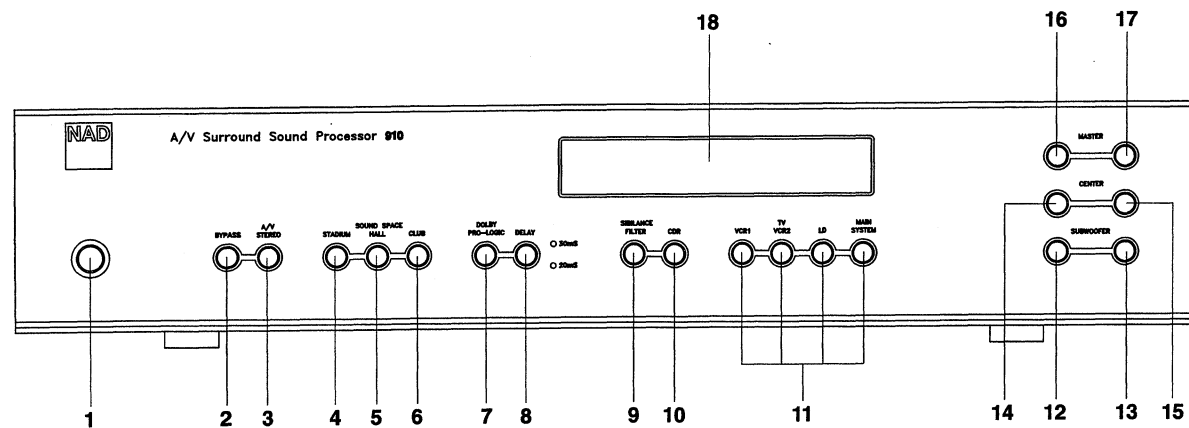

- | | | |
|------------------------|----------------------------|--------------------------|
| 1. Power | 7. Dolby Pro-Logic | 13. Subwoofer Level - Up |
| 2. Bypass | 8. Delay | 14. Center Level - Down |
| 3. A/V Stereo | 9. Sibilance Filter | 15. Center Level - Up |
| 4. Stadium Sound Space | 10. CDR | 16. Master Level - Down |
| 5. Hall Sound Space | 11. Input Selector | 17. Master Level - Up |
| 6. Club Sound Space | 12. Subwoofer Level - Down | 18. Display |

The lightning flash with arrowhead symbol, within an equilateral triangle, is intended to alert the user to the presence of uninsulated "dangerous voltage" within the product's enclosure, that may be of sufficient magnitude to constitute a risk of electric shock to persons.

The exclamation point within an equilateral triangle is intended to alert the user of the presence of important operating and maintenance (servicing) instructions in the literature accompanying the appliance.

REAR PANEL

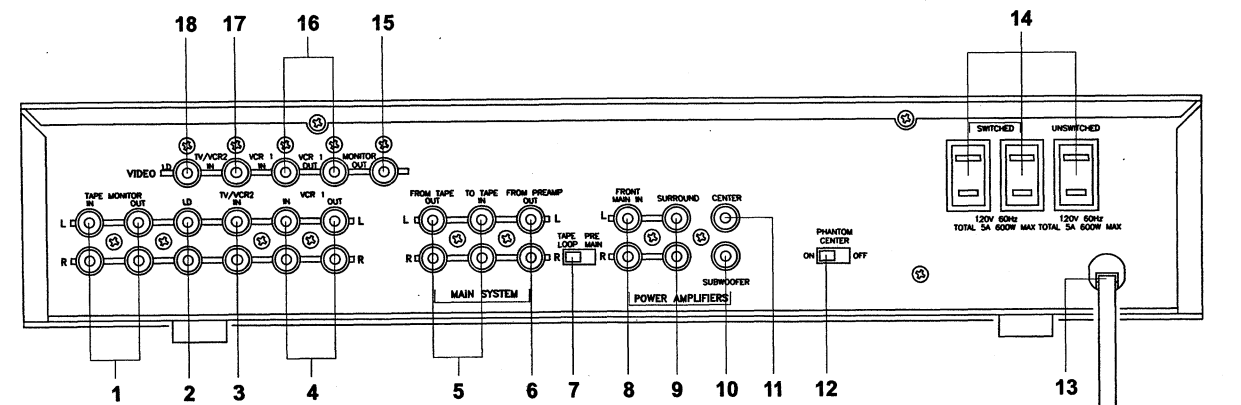

- | | | |
|------------------------------------|------------------------------|----------------------------------|
| 1. Tape Monitor Input/Output | 7. Tape Loop/Pre-Main Switch | 13. AC Line Cord |
| 2. LD Audio Input | 8. Front Main In Output | 14. AC Outlets (AH Version Only) |
| 3. TV/VCR2 Audio Input | 9. Surround Output | 15. Video Monitor Output |
| 4. VCR1 Audio Input/Output | 10. Subwoofer Output | 16. VCR1 Video Input/Output |
| 5. Main System - Tape Output/Input | 11. Center Output | 17. TV/VCR2 Video Input |
| 6. Main System - Preamp Output | 12. Phantom Center Switch | 18. LD Video Input |

ALIGNMENT PROCEDURE

CDR

1. Select LD input and HALL mode at front panel, and PRE-MAIN and PHANTOM CENTER off at rear panel.
2. Connect AC voltmeter to FRONT MAIN IN.
3. Apply 177mV to LD input, left channel only.
4. Switch CDR off and take note of the output level.
5. Switch CDR on.
6. Adjust TVR101 for 5dB increase in output level.
7. Remove input signal at left channel and put to right channel.
8. Repeat steps 4 to 6, adjusting TVR201.
9. Repeat the whole procedure if the difference between left and right output levels exceed 0.2dB.

Instrument Setup

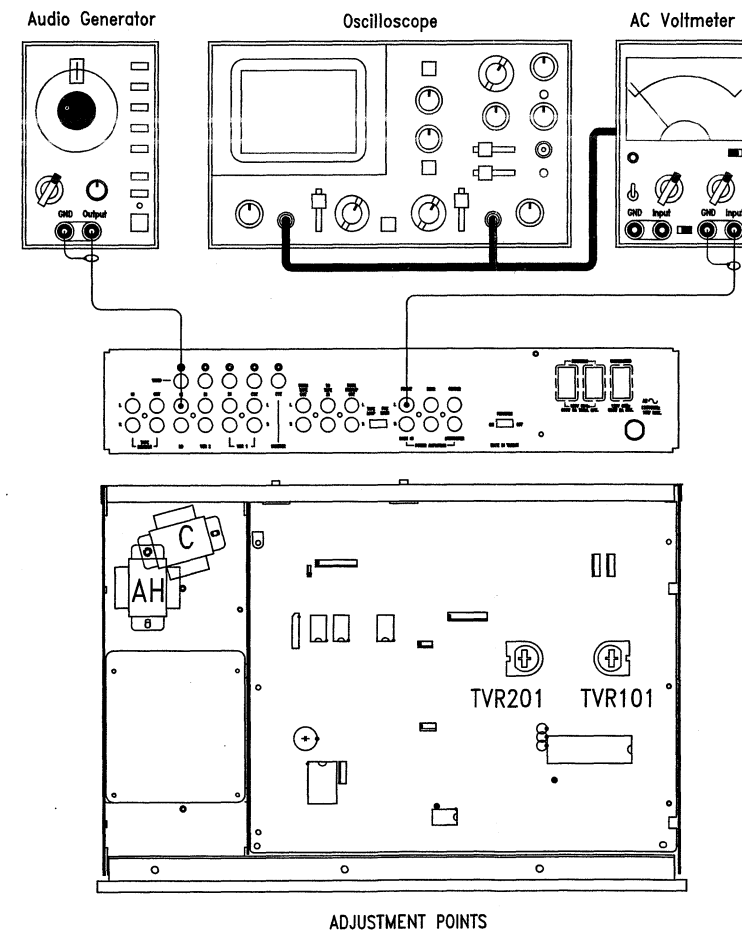

ADJUSTMENT POINTS

WIRING DIAGRAM

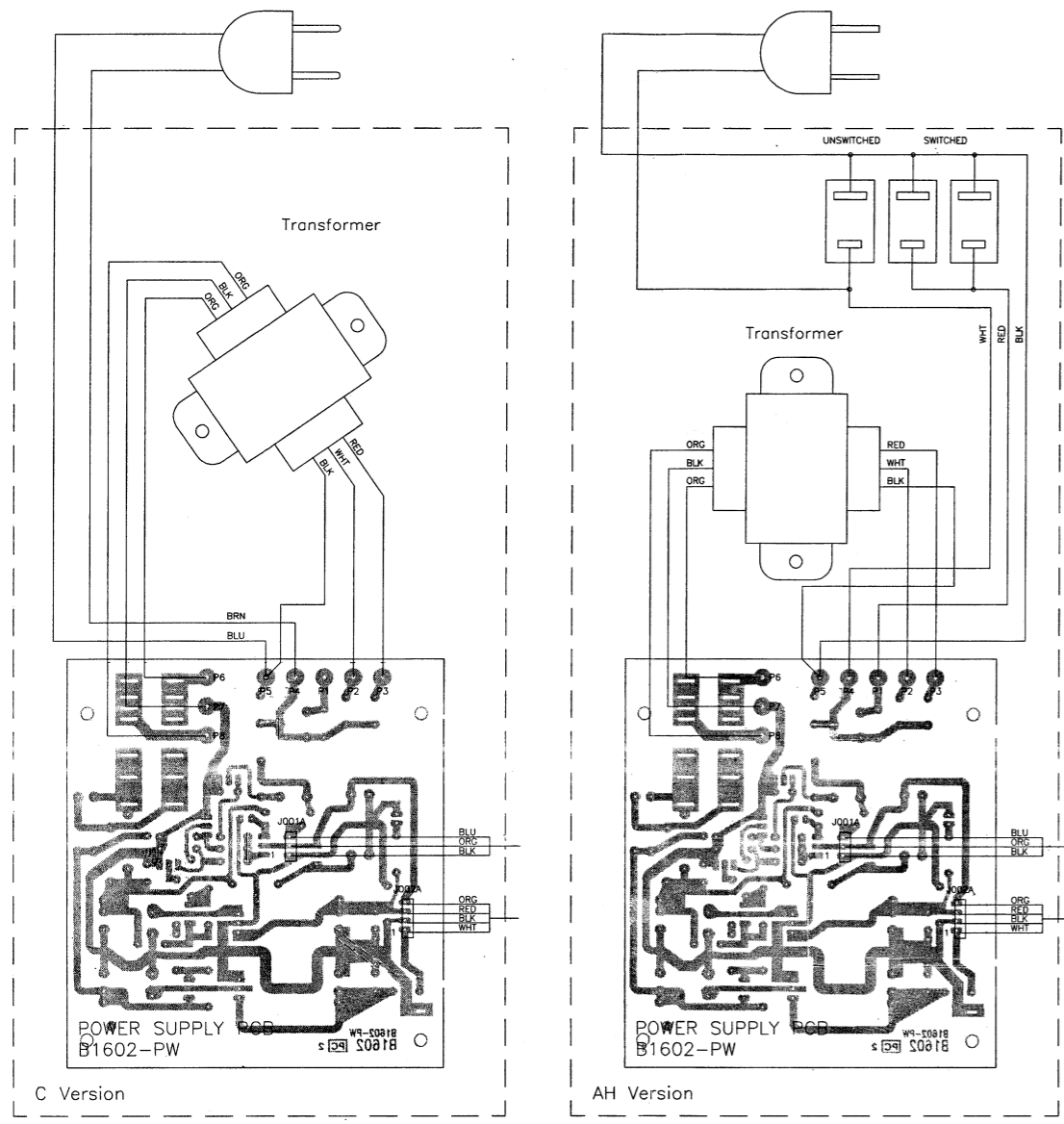

NOTE:
ALL PCBs SHOWN COMPONENT SIDE.

- LEGEND:
- BLK - BLACK
 - BRN - BROWN
 - RED - RED
 - ORG - ORANGE
 - YEL - YELLOW
 - GRN - GREEN
 - BLU - BLUE
 - VIO - VIOLET
 - GRY - GRAY
 - WHT - WHITE

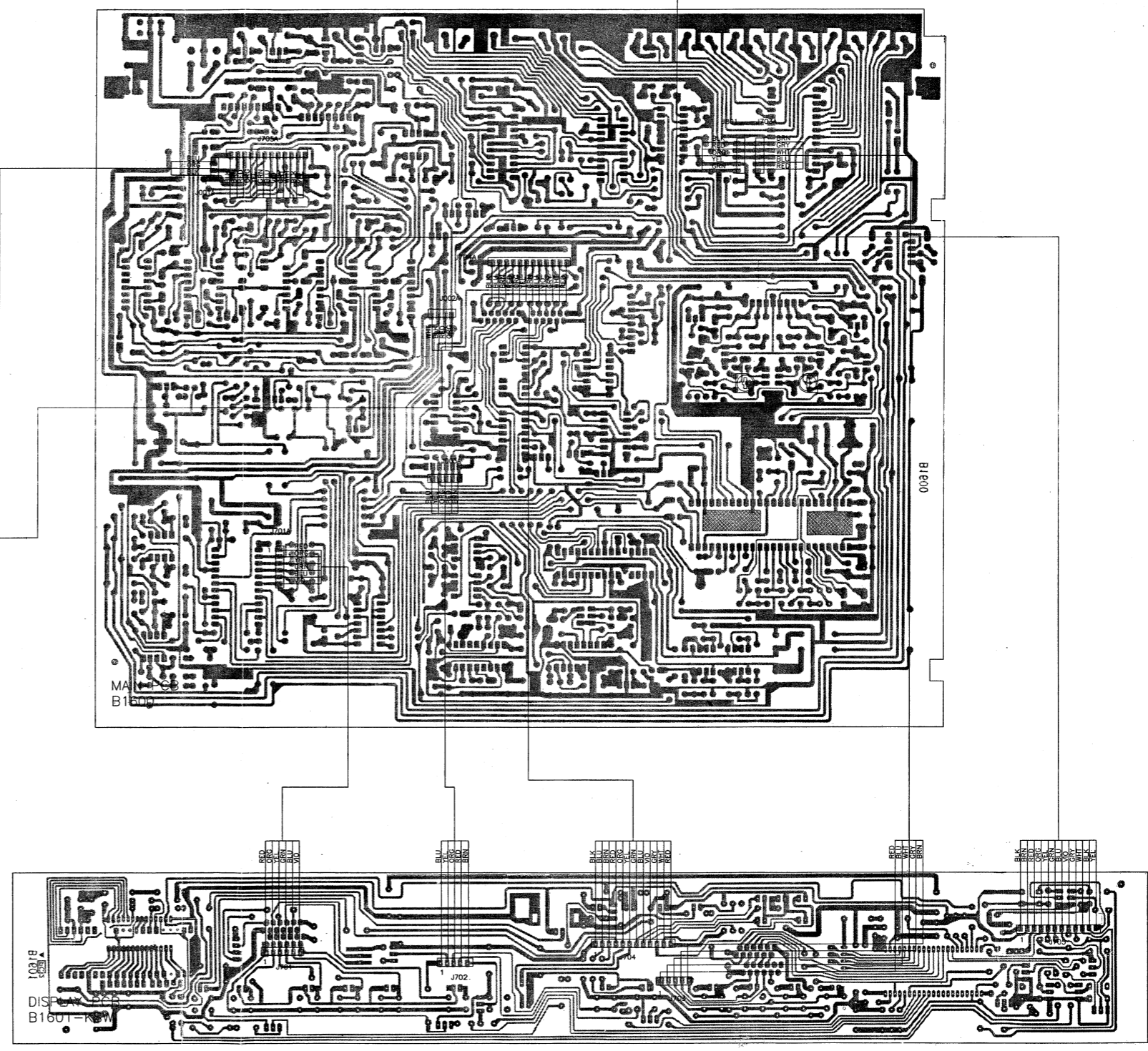
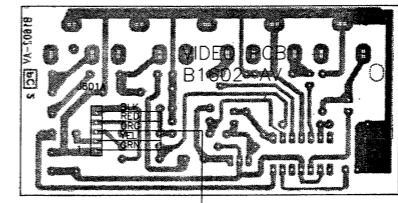

SCHEMATIC DIAGRAMS

Note:

All resistors, unless otherwise specified, are either 1/4W or 1/6W carbon film.
Components marked with Δ are safety critical parts.

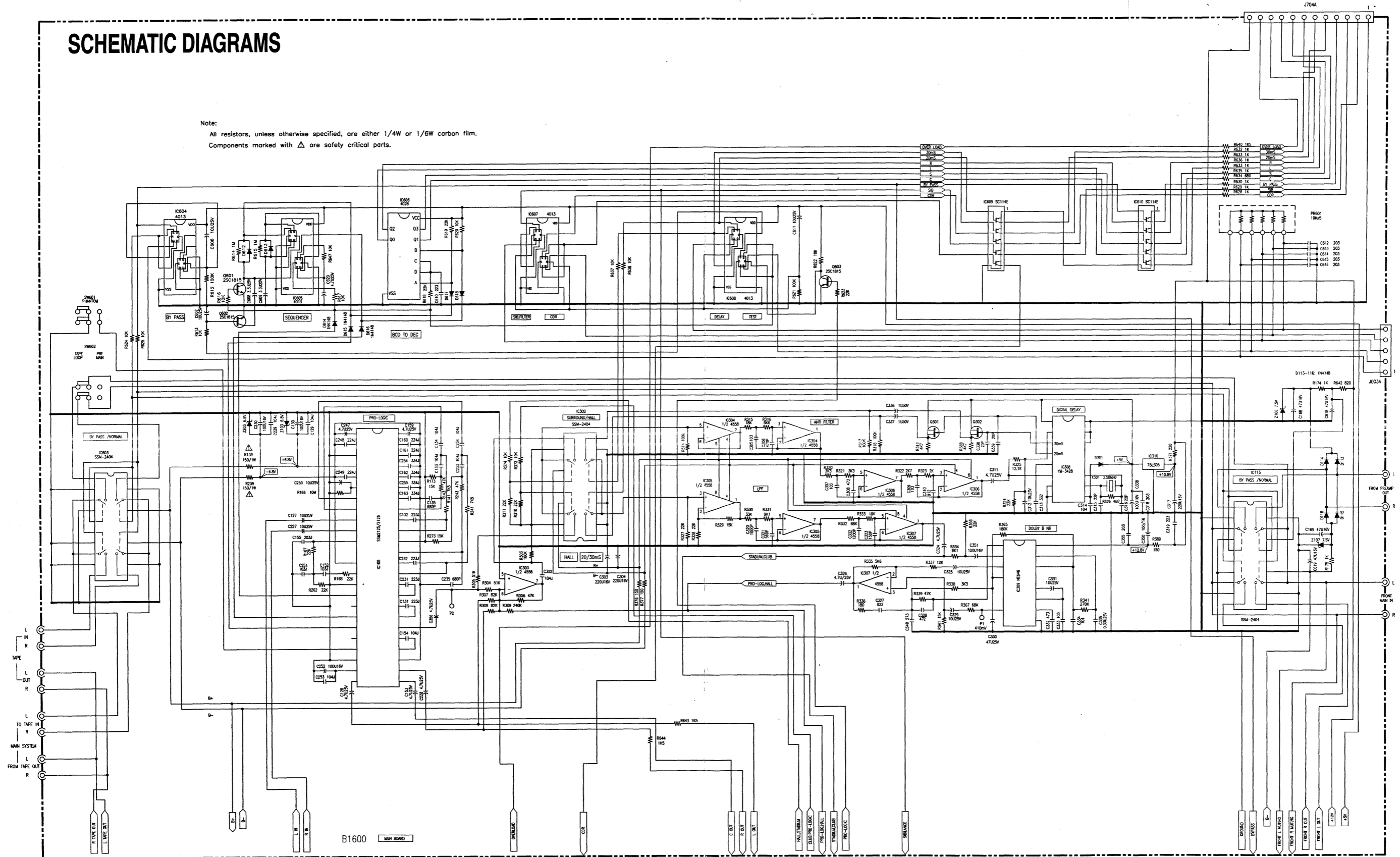

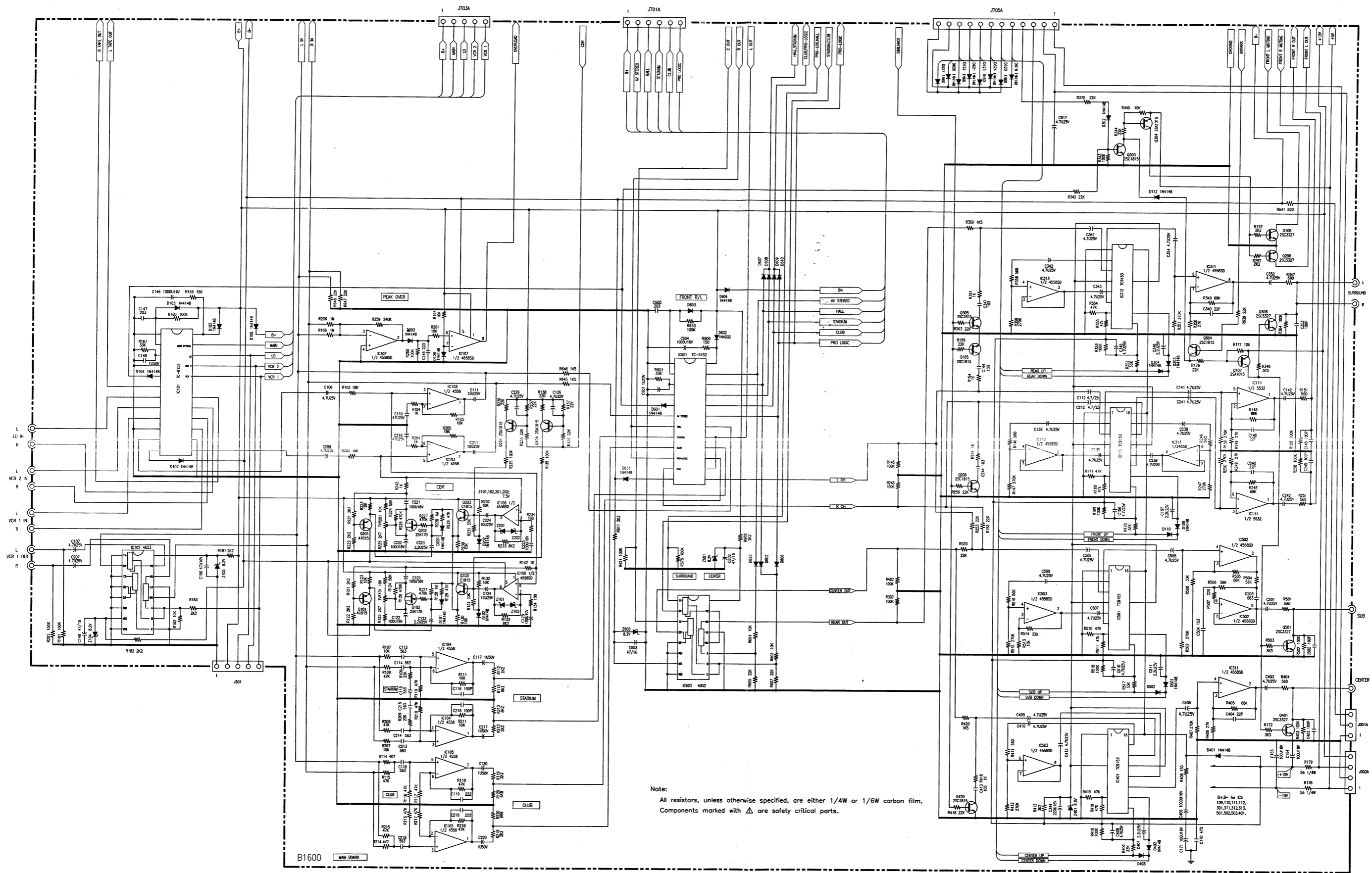

Note:
 All resistors, unless otherwise specified, are either 1/4W or 1/5W carbon film.
 Components marked with Δ are safety critical parts.

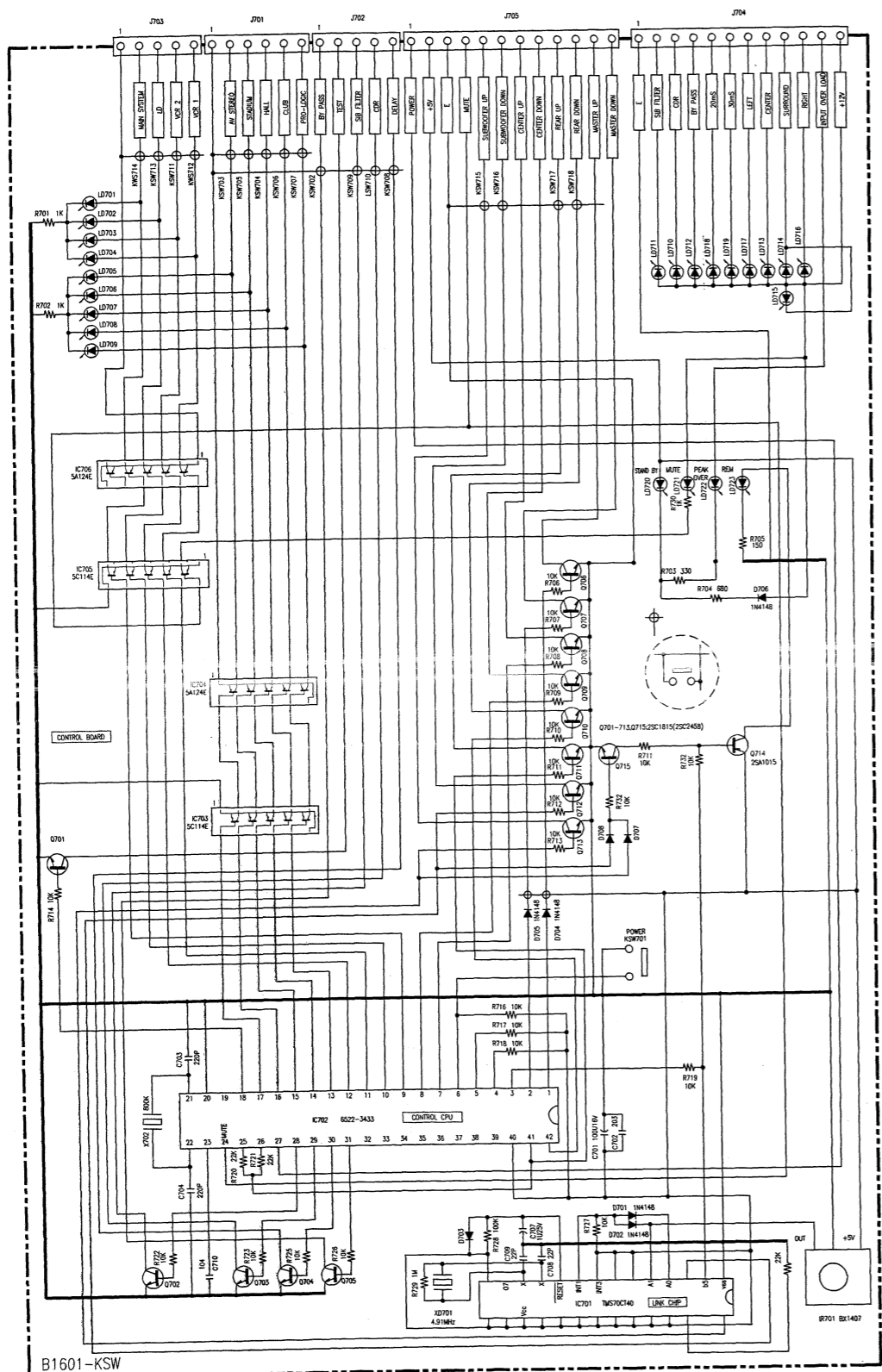

Note:
 All resistors, unless otherwise specified, are either 1/4W or 1/6W carbon film.
 Components marked with Δ are safety critical parts.

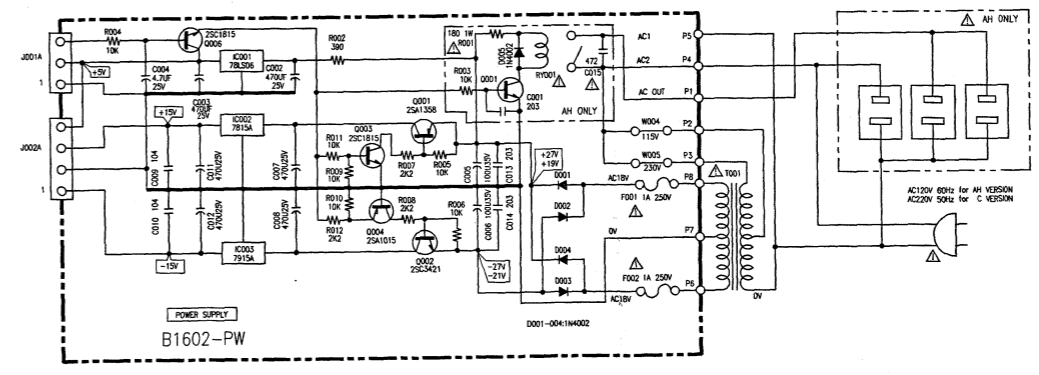
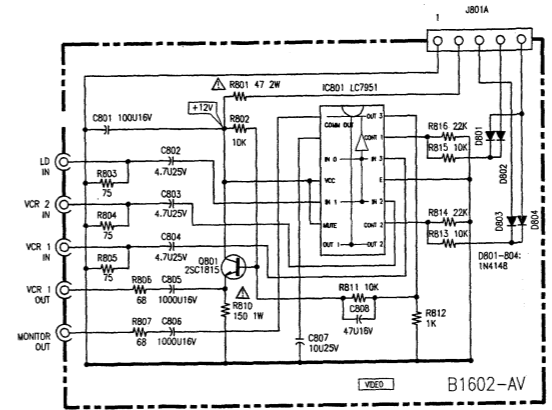

PCB LAYOUTS

MAIN PCB

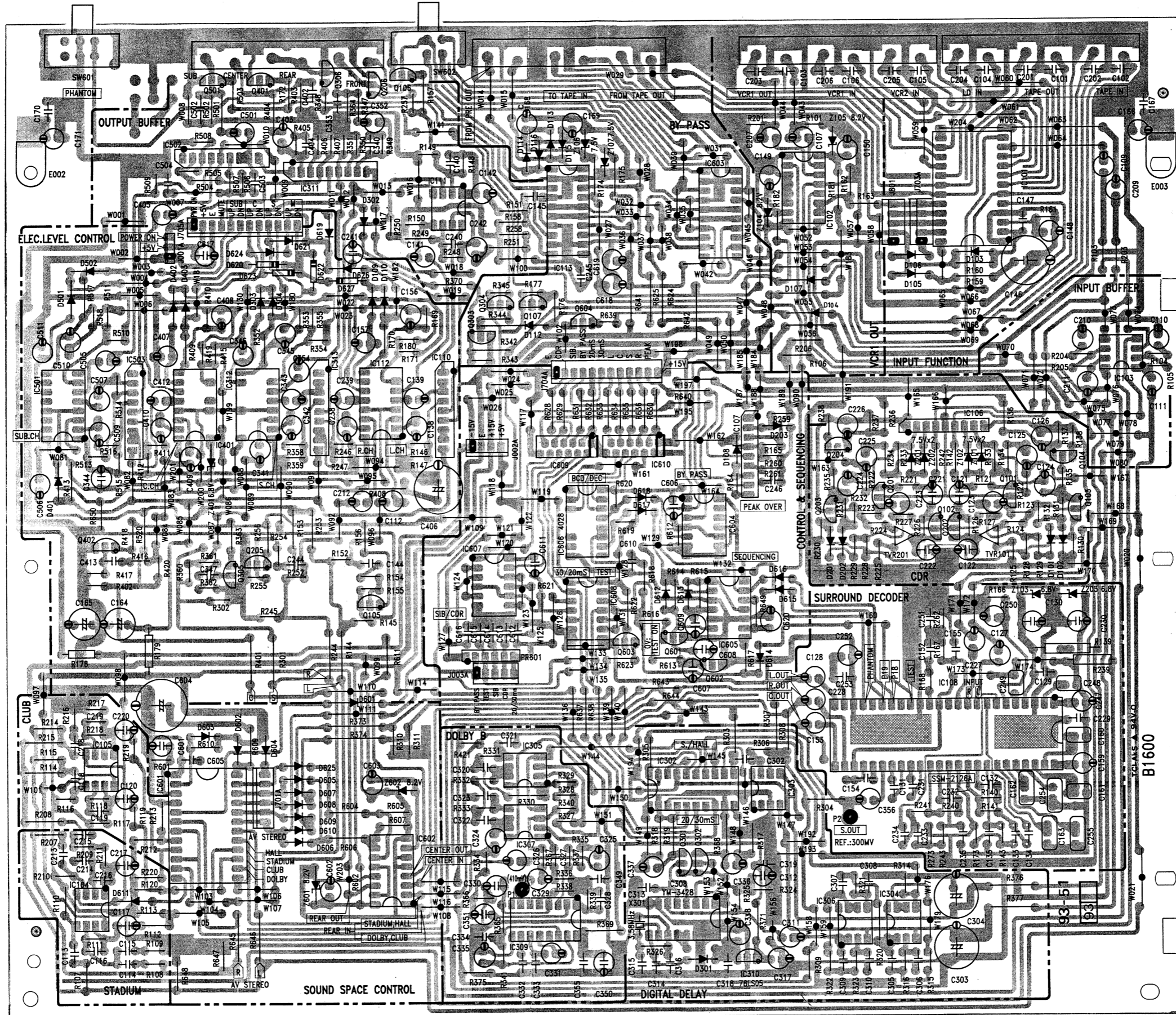

DISPLAY PCB

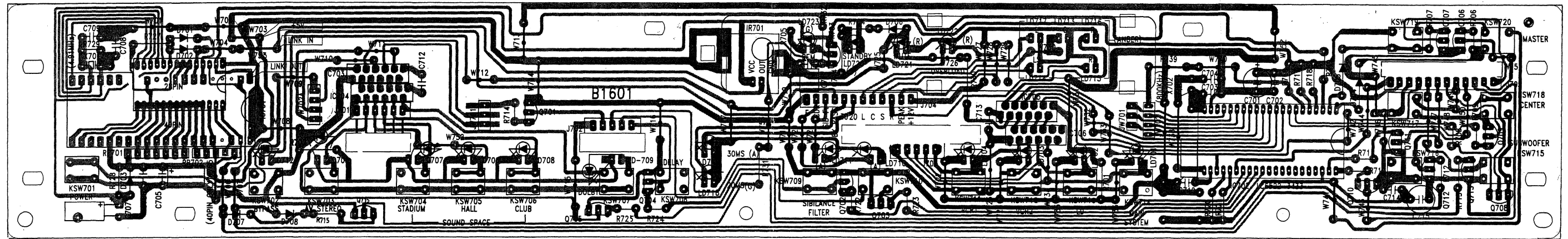

POWER SUPPLY PCB

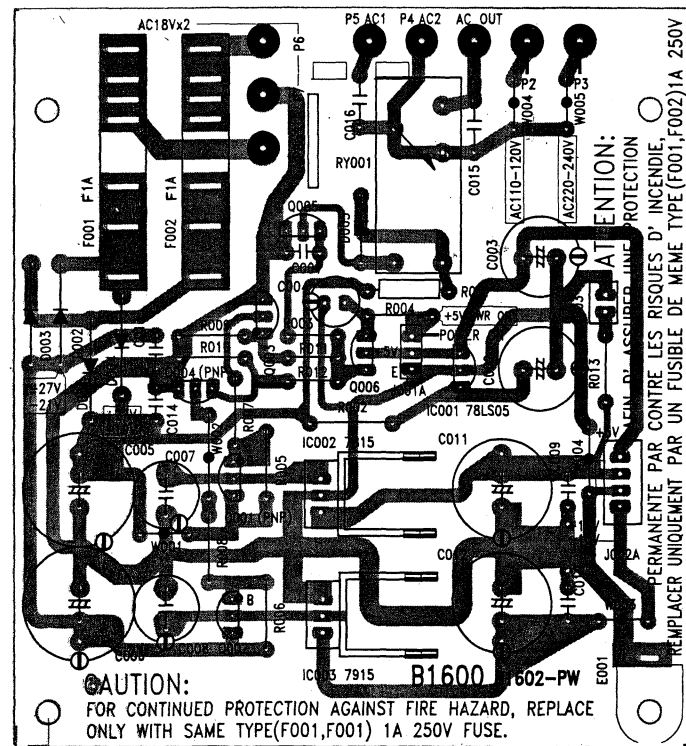

VIDEO PCB

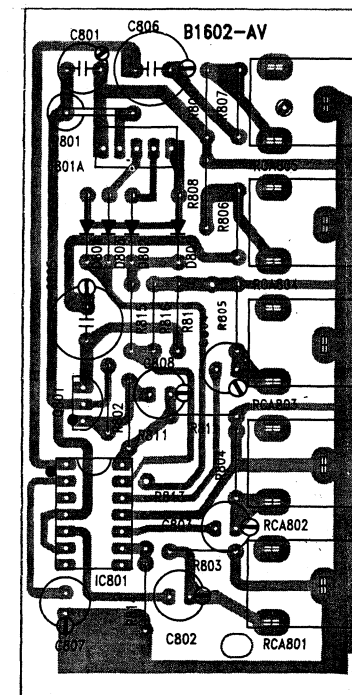

IC BLOCK DIAGRAMS

JRC4558/NE5532

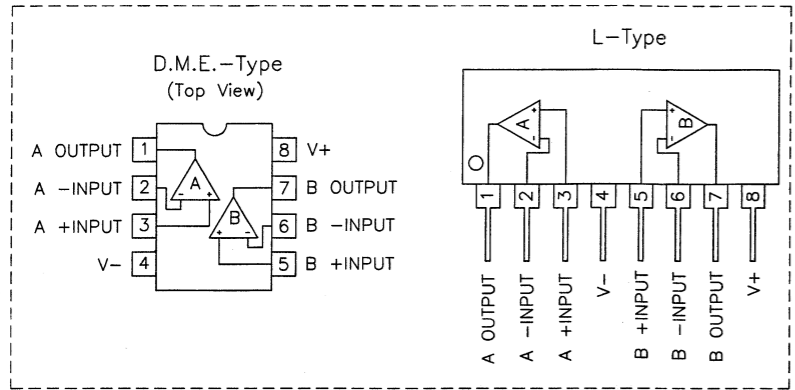

TC-4028

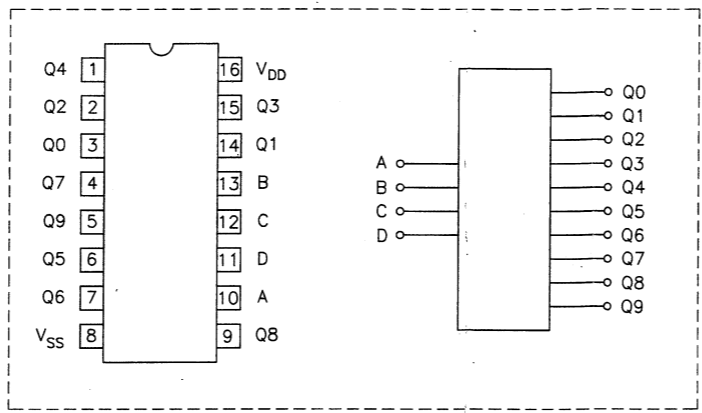

TC9152

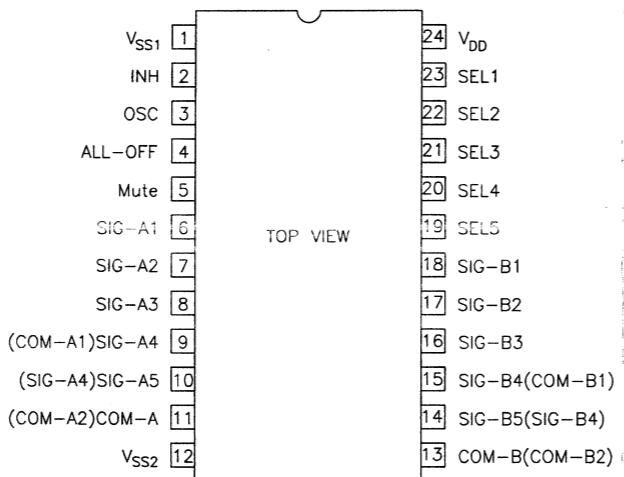

TMS70CT40

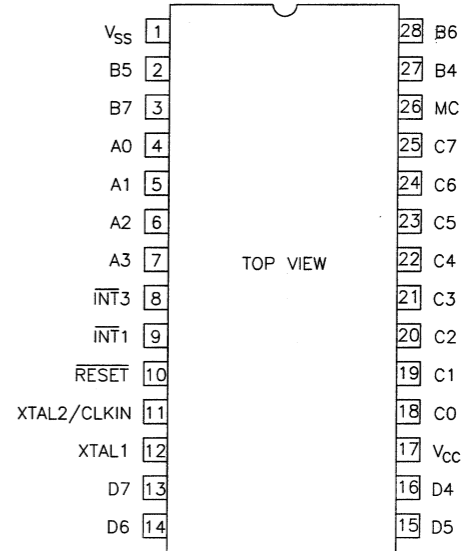

SSM-2126

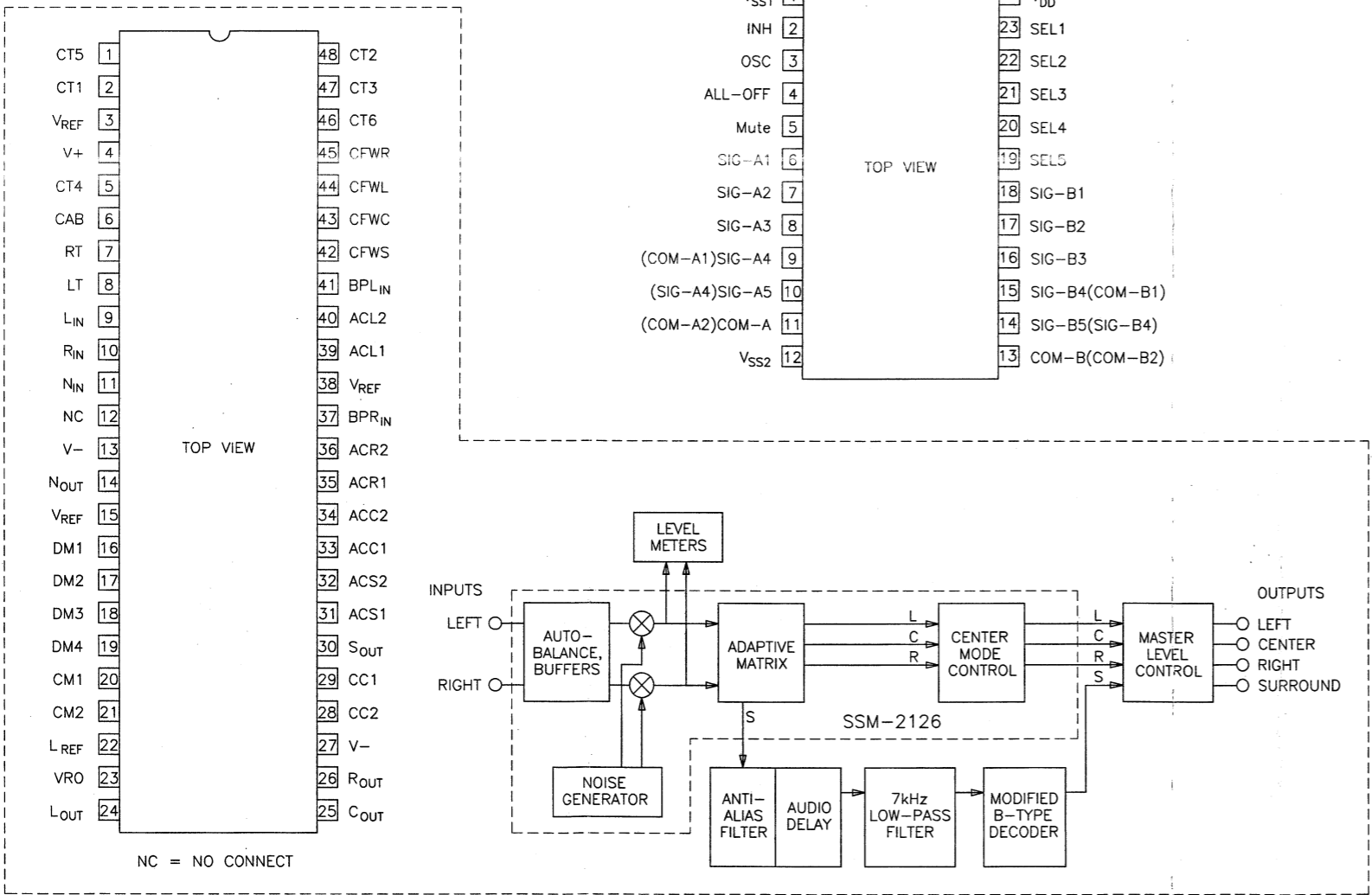

SSM-2404

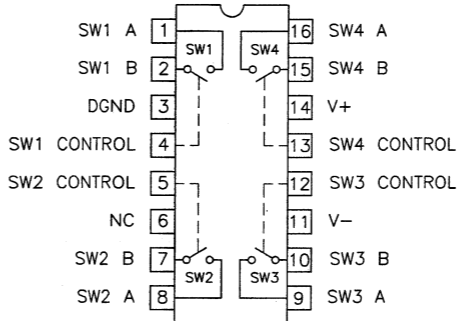

YM-3428

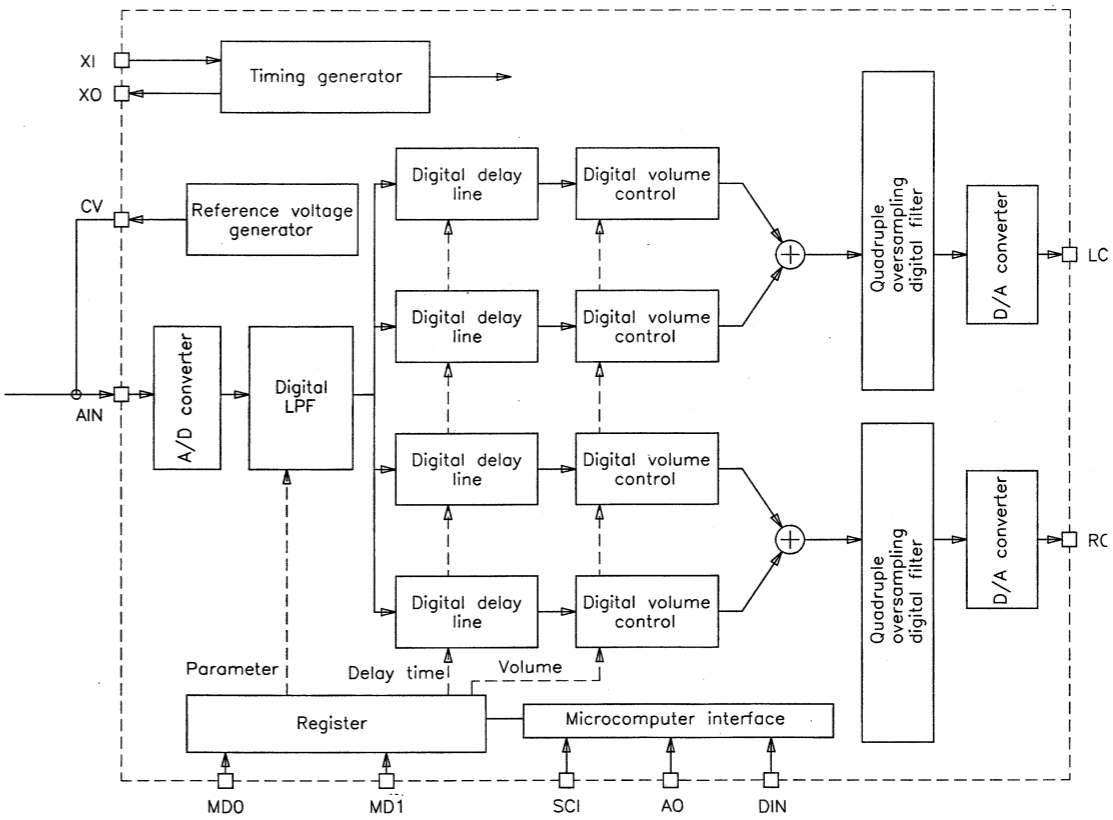

NE646

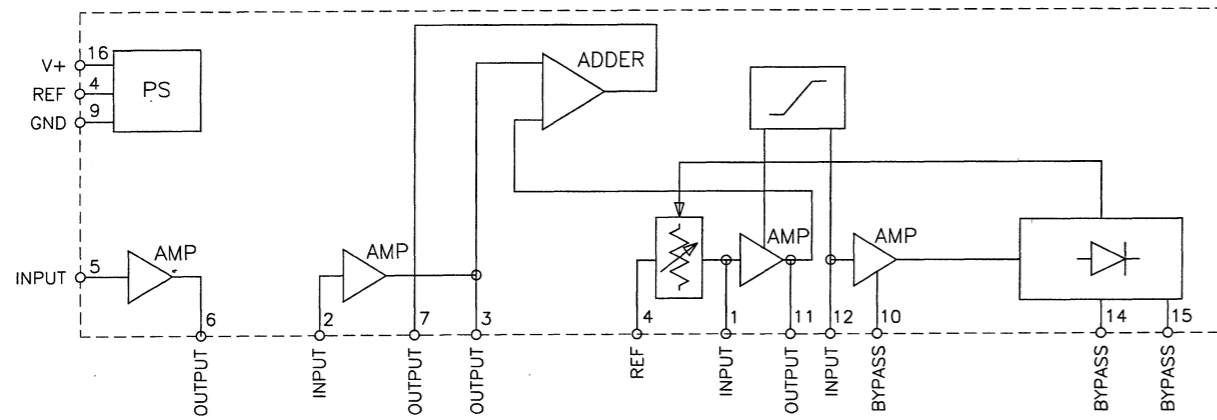

TC4053

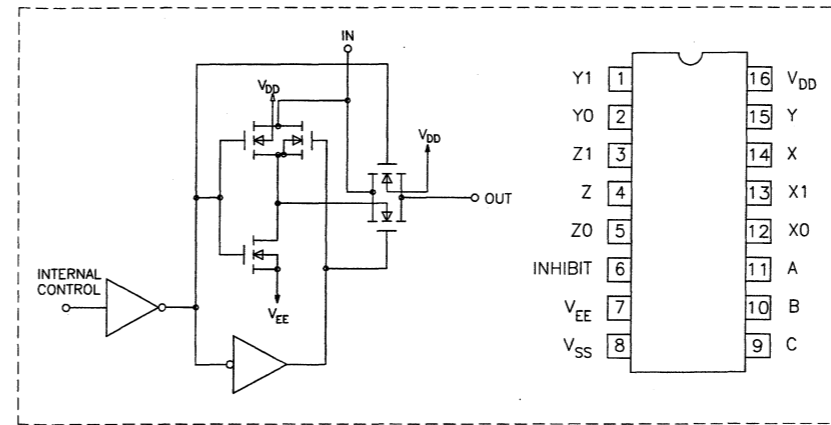

TC-4013

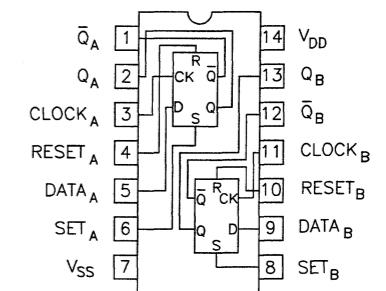

TC9153P

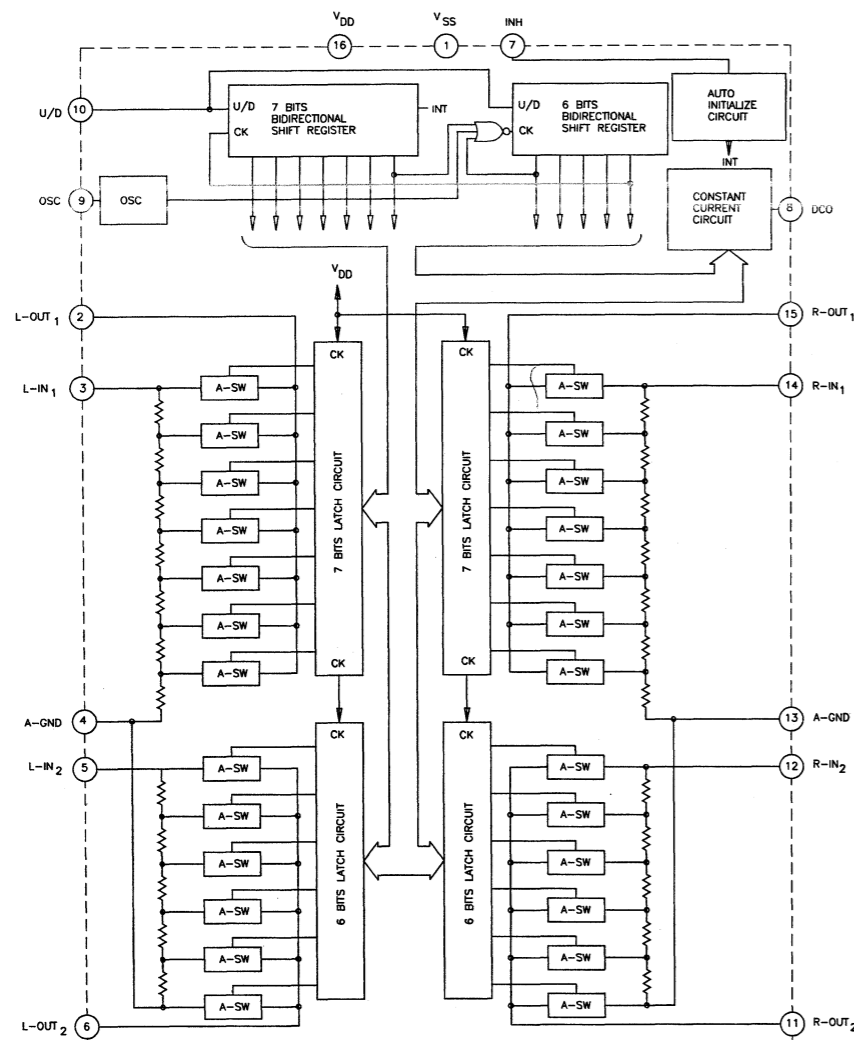



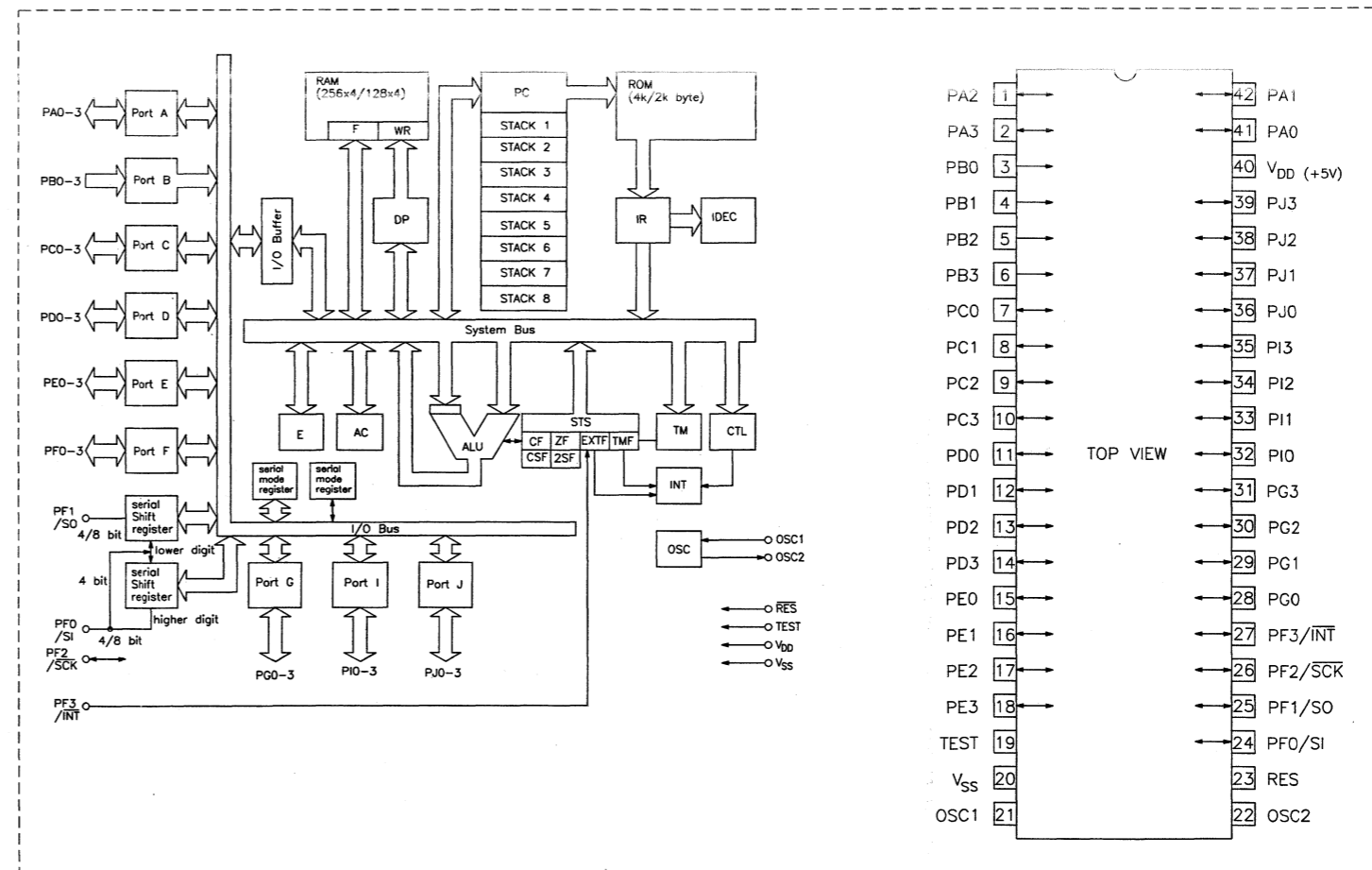

6522C-3433

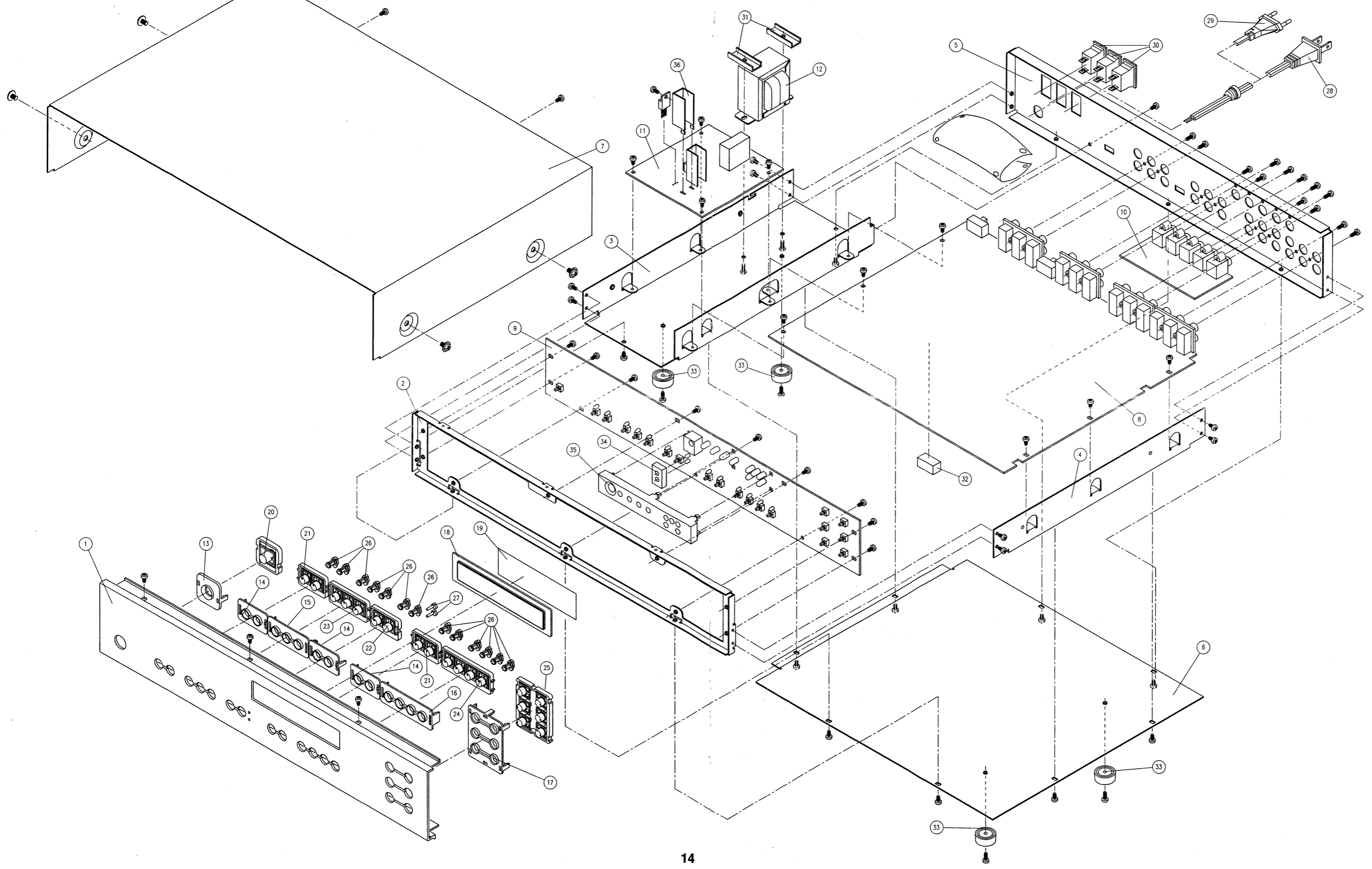

EXPLODED VIEW







EXPLODED VIEW PARTS LIST

ITEM NO.	PART NUMBER	DESCRIPTION	QTY.
1	78L438	Front Panel L-438	1
2	78C1845	Subfascia C-1845	1
3	78C1847	Chassis, Left C-1847	1
4	78C1849	Side Panel C-1849	1
5	99RSC1846A	Rear Panel C-1846AH (AH)	1
	99RSC1846B	Rear Panel C-1846C (C)	1
6	78C1848	Bottom Plate C-1848	1
7	78C1850	Top Cover C-1850	1
8	97B1600	Main PCB B1600 with components	1
9	97B1601KSW	Display PCB B1601-KSW with components	1
10	97B1602AV	Video PCB B1602-AV with components	1
11	97B1602PW	Power Supply PCB B1602-PW with components	1
12	70EMUV910	Transformer 	1
13	88A445	Power Bezel A-445	1
14	88A4442P	Dual Bezel A-444	3
15	88A4433P	Triple Bezel A-443	1
16	88A4424P	4-way Bezel A-442	1
17	88A4406P	6-way Bezel A-440	1
18	85A439	Acrylic Window A-439	1
19	85A446	Diffuser	1
20	20KB315	Button, Power	1
21	20KB313	Push Sw 2P KB-313	2
22	20KB314	Push Sw 2P KB-314	1
23	20KB312	Push Sw 3P KB-312	1
24	20KB311	Push Sw 4P KB-311	1
25	20KB310	Push Sw 6P KB-310	1
26	85A441	Acrylic Pin A-441	13
27	85A447	Acrylic Pin A-447	2
28	682SPT22B	AC Cord SPT-2 (AH) 	1
29	682PVDE2B	AC Cord 2P VDE (C) 	1
30	55AC0715	AC Socket AC004 (AH) 	3
31	78C1346	Bracket C-1346	2
32	84SNAD910	Sponge	1
33	81FT35NAD	Foot 4TR-1257A	4
34	84E289	LED Holder	1
35	88A446	Frame, LED A-446	1
36	78H042	Heat Sink H-042 White	2

ELECTRICAL PARTS LIST

PART NUMBER	REFERENCE NUMBER	DESCRIPTION	REMARKS
Video PCB			
97B1602AV		AV PCB Assembly B1602-AV	
300047M2TJ	R801	Resistor Metal Oxide 2W T 10% 47	⚠
30010KC4TJ	R802,811,813,815	Resistor Carbon 1/4W T 5% 10K	
300075C4TJ	R803,804,805	Resistor Carbon 1/4W T 5% 75	
300068C4TJ	R806,807	Resistor Carbon 1/4W T 5% 68	
300150M1TJ	R810	Resistor Metal Oxide 1W T 5% 150	⚠
30001KC4TJ	R812	Resistor Carbon 1/4W T 5% 1K	
30022KC4TJ	R814,816	Resistor Carbon 1/4W T 5% 22K	
40100U16RM	C801	Capacitor Electrolytic 100uF 16V	
04P7U25RM	C802,803,804	Capacitor Electrolytic 4.7uF 25V	
01KU16RM	C805,806	Capacitor Electrolytic 1000uF 16V	
40010U25RM	C807	Capacitor Electrolytic 10uF 25V	
40047U16RM	C808	Capacitor Electrolytic 47uF 16V	
131N4148TO	D801,802,803,804	Diode 1N4148	
11LC7951	IC801	I.C. LC7951	
122SC1815	Q801	Transistor 2SC1815	
Power Supply PCB			
97B1602PW		Power Supply PCB Assembly B1602-PW	
300150M1TJ	R001	Resistor Metal Oxide 1W T 10% 150	⚠
300390C4TJ	R002	Resistor Carbon 1/4W T 5% 390	
30010KC4TJ	R004,005,006,009,010	Resistor Carbon 1/4W T 5% 10K	
3002K2C4TJ	R007,008	Resistor Carbon 1/4W T 5% 2K2	
41203U50RJ	C001	Capacitor Mylar 203 50V	AH Only
0470U25RM	C002,003,007,008	Capacitor Electrolytic 470uF 25V	
404P7U50RM	C004	Capacitor Electrolytic 4.7uF 50V	
01KU35RM	C005,006	Capacitor Electrolytic 1000uF 35V	
5104U53MD	C009,010	Capacitor MPD-D 104 250V	
40470U25RM	C011,012	Capacitor Electrolytic 470uF 25V	
42203U50RJ	C013,014	Capacitor Ceramic 203 50V	
2472250VU	C015	Capacitor VDE 472 250V	⚠ AH Only
1178LS05	IC001	I.C. 78LS05	
117815A	IC002	I.C. 7815A	
117915A	IC003	I.C. 7915A	
122SA1358	Q001	Transistor 2SA1358	
122SC3421	Q002	Transistor 2SC3421	
122SC1815	Q003,006	Transistor 2SC1815	
122SA1015	Q004	Transistor 2SA1015	
12SD468	Q005	Transistor 2SD468	AH Only
131N4002TO	D001,002,003,004	Diode 1N4002	
131N4002TO	D005	Diode 1N4002	AH Only
6112V3VMX1	RY001	Relay 12V3A MX1	⚠ AH Only
595G0012F	F001, F002*AH	Fuse 1A/250V fast blow, glass UL/CSA	⚠ AH Only
595G00123F	F001, F002*C	Fuse F1AL/250V SEMKO/VDE	⚠ C Only
Display PCB			
97B1601KSW		Display PCB Assembly B1601-KSW	
300680C4TJ	R701,702	Resistor Carbon 1/4W T 5% 680	
300330C4TJ	R703	Resistor Carbon 1/4W T 5% 330	
300150C4TJ	R705	Resistor Carbon 1/4W T 5% 150	
3002K2C4TJ	R730	Resistor Carbon 1/4W T 5% 2K2	
30010KC4TJ	R731,732,W733	Resistor Carbon 1/4W T 5% 10K	
42220U16RM	C701	Capacitor Electrolytic 220uF 16V	
42203U50RJ	C702,706	Capacitor Ceramic 203 50V	
42220P50RJ	C703,704	Capacitor Ceramic 220P 50V	
42100U16RM	C705	Capacitor Electrolytic 100uF 16V	
40001U50RM	C707	Capacitor Electrolytic 1uF 50V	
42022P50RJ	C708,709	Capacitor Ceramic 22P 50V	
400P1U50RM	C710	Capacitor Electrolytic 0.1uF 50VKULR	
131N4148TO	D701-708	Diode 1N4148	
11TMS77C82	IC701	I.C. TMS70CT40	
11LC6522	IC702	I.C. LC-6522-3433	
11BC114E	IC703,705	I.C. BC114E (5C114AE)	
11BA124E	IC704,706	I.C. BA124E (5A124E)	
122SC1815	Q701-713,715	Transistor 2SC1815/2SC2458	
122SA1015	Q714	Transistor 2SA1015	

PART NUMBER	REFERENCE NUMBER	DESCRIPTION	REMARKS
50C4P91	X701	Crystal Oscillator,Ceramic 4.91MHz	
50C800J	X702	Crystal Oscillator,Ceramic 800J/800K	
163XGT0005	LD701-709	LED 3XGT Green	
163XAT0004	LD710,711	LED 3XAT Yellow	
163XGT0005	LD712,718	LED 3XGT Green	
1605L53YD4	LD713-717,719	LED L-53YD Yellow	
1605L53GD5	LD720,723	LED L-53GD 530010KC6TJ	
1605L53ID2	LD721,722	LED L-53ID Red	
85BX1407	IR701	Receiver BX-1407	
85B351050	KSW701-720	Tact Switch B35-1050	
Main PCB			
97B1600		Main PCB Assembly B1600	
3004K7C4TJ	R114,319,368	Resistor Carbon 1/4W T 5% 4K7	
300150M1TJ	R139,239	Resistor Metal Oxide 1W T 10% 150	⚠
30022KC4TJ	R153,253,342,370,520	Resistor Carbon 1/4W T 5% 22K	
3003K3C4TJ	R157,320,413	Resistor Carbon 1/4W T 5% 3K3	
300150C4TJ	R159,369,609	Resistor Carbon 1/4W T 5% 150	
30100KC4TJ	R160,303,318	Resistor Carbon 1/4W T 5% 100K	
30001KC4TJ	R174,635,636	Resistor Carbon 1/4W T 5% 1K	
30001KC4TJ	R175,628-633	Resistor Carbon 1/4W T 5% 1K	
300056C4TJ	R178,179	Resistor Carbon 1/4W T 5% 56	
3002K2C4TJ	R181,602,611	Resistor Carbon 1/4W T 5% 2K2	
30047KC4TJ	R208,215	Resistor Carbon 1/4W T 5% 47K	
300560C4TJ	R251,404,501	Resistor Carbon 1/4W T 5% 560	
30082KC4TJ	R307,308	Resistor Carbon 1/4W T 5% 82K	
30033KC4TJ	R330,517	Resistor Carbon 1/4W T 5% 33K	
300220C4TJ	R371	Resistor Carbon 1/4W T 5% 220	
30010KC4TJ	R373,374,625	Resistor Carbon 1/4W T 5% 10K	
300150C4TJ	R376,377,408	Resistor Carbon 1/4W T 5% 150	
30010KC4TJ	R604,606,622	Resistor Carbon 1/4W T 5% 10K	
30010KC4TJ	R624,637,638	Resistor Carbon 1/4W T 5% 10K	
300470C4TJ	R634	Resistor Carbon 1/4W T 5% 470	
3001K5C4TJ	R640,643,644-646	Resistor Carbon 1/4W T 5% 1K5	
300820C4TJ	R641,642	Resistor Carbon 1/4W T 5% 820	
3010Kx5	PR601	Resistor Carbon 10Kx5	
40100P50RM	C101-106,201-206	Capacitor Ceramic 100PF 50V	
404P7U25RM	C107,109,207,209	Capacitor Electrolytic 4.7uF 25V	
4004U25RM	C110,149,150,210	Capacitor Electrolytic 47uF 25V	
40010U25RM	C111,124,211,312,331	Capacitor Electrolytic 10uF 25V	
404P7U25RM	C112,153,228,409,505	Capacitor Electrolytic 4.7uF 25V	
41563U50RJ	C113,114,213,214	Capacitor Ceramic 563 50V	
41563U50RJ	C115,118,215,218	Capacitor Ceramic 563 50V	
42100P50RJ	C116,216,353,402,502	Capacitor Ceramic 100P 50V	
40001U25RM	C117,217,337,601	Capacitor Electrolytic 1uF 25V	
41222U50RJ	C119,219	Capacitor Ceramic 222 50V	
40001U25RM	C120,148,220,336	Capacitor Electrolytic 1uF 25V	
40100U16RM	C121,130,221,330,338	Capacitor Electrolytic 100uF 16V	
40100U16RM	C122,171,222,350	Capacitor Electrolytic 100uF 16V	
402P2U25RM	C123,157,223	Capacitor Electrolytic 2.2uF 25V 10%	
40100U16RM	C125,225,230,252	Capacitor Electrolytic 100uF 16V	
404P7U25RM	C126,226,341,351	Capacitor Electrolytic 4.7uF 25V	
40010U25RM	C127,224,329,611	Capacitor Electrolytic 10uF 25V	
404P7U25RM	C128,352,356,509	Capacitor Electrolytic 4.7uF 25V	
41104U50RJ	C129,154,229,233	Capacitor Ceramic 104 50V	
41223U50RJ	C131,132,231,318	Capacitor Ceramic 223 50V	
41104U50RJ	C133,234,253	Capacitor Ceramic 104 50V	
41104U50RJ	C134,302,314,334	Capacitor Ceramic 104 50V	
47680P50RJ	C135,235	Capacitor PP 680P 50V	
404P7U25RM	C138,212,247,343	Capacitor Electrolytic 4.7uF 25V	
404P7U25RM	C139,159,238,239	Capacitor Electrolytic 4.7uF 25V	
42022P50RJ	C140,240,315	Capacitor Ceramic 22P 50V	
404P7U25RM	C141,241,354,506,620	Capacitor Electrolytic 4.7uF 25V	
404P7U25RM	C142,405,501,507	Capacitor Electrolytic 4.7uF 25V	
41103U50RJ	C144,244,305,307,309	Capacitor Ceramic 103 50V	
42100P50RJ	C145,245	Capacitor Ceramic 100P 50V	
4001KU16RM	C146,406,604	Capacitor Electrolytic 1000uF 16V	
41223U50RJ	C147,355,605	Capacitor Ceramic 223 50V	
41103U50RJ	C152,251,333,347,413	Capacitor Ceramic 103 50V	
41203U50RJ	C155	Resistor Carbonic 203 50V	
404P7U25RM	C156,345,408,510	Capacitor Electrolytic 4.7uF 25V 10%	
43224U50RJ	C160,161,248,249	Capacitor Metal 224 50V	
43334U50RJ	C162,163,254,255	Capacitor Metal 334 50V	

PART NUMBER	REFERENCE NUMBER	DESCRIPTION	REMARKS
40220U16RM	C164,165,344	Capacitor Electrolytic 220uF 16V	
42203U50RJ	C170,612-616	Capacitor Ceramic 203 50V	
40010U25RM	C227,250,325,606,607	Capacitor Electrolytic 10uF 25V	
41223U50RJ	C232,246,319,610	Capacitor Ceramic 223 50V	
404P7U25RM	C242,311,324,342	Capacitor Electrolytic 4.7uF 25V	
47470P50RJ	C306	Capacitor PP 470P 50V	
41472U50RJ	C308,328	Capacitor Ceramic 472 50V	
4191KP50RJ	C310	Capacitor Ceramic 100P 50V	
41332U50RJ	C313	Capacitor Ceramic 332 50V	
42022P50RJ	C316,340,404	Capacitor Ceramic 22P 50V	
41102U50RJ	C320	Capacitor Ceramic 102 50V	
47560P50RJ	C321	Capacitor PP 560P 50V	
41122U50RJ	C322	Capacitor Ceramic 122 50V	
47150P50RJ	C323	Capacitor PP 150P 50V	
404P7U25RM	C326,403,410,412	Capacitor Electrolytic 4.7uF 25V	
41822U50RJ	C327	Capacitor Ceramic 822 50V	
41473U50RJ	C332	Capacitor Ceramic 473 50V	
40P33U25RM	C335	Capacitor Electrolytic 0.33uF 25V	10%
402P2U25RM	C346,407,511	Capacitor Electrolytic 2.2uF 25V	10%
41273U50RJ	C349	Capacitor Ceramic 273 50V	
41683U50RJ	C503	Capacitor Ceramic 683 50V	
41153U50RJ	C504	Capacitor Ceramic 153 50V	
40047U25RM	C602,603,618,619	Capacitor Electrolytic 47uF 25V	
403P3U25RM	C608,609	Capacitor Electrolytic 3.3uF 25V	10%
131N4148TO	D101-106,108-110	Diode 1N4148	
131N4148TO	D107,112,601	Diode 1N4148	
131N4148TO	D113-116,602-619,621	Diode 1N4148	
131N4148TO	D201-203,401-403,502	Diode 1N4148	
131N4148TO	D301-304,501,624-626	Diode 1N4148	
1320A90*TO	D620,622,623,627	Diode 20A90/1N60	
13Z6P8P5TO	Z103,203,401	Zener Diode 6.8V	
13Z7P5P5TO	Z101,102,106	Zener Diode 7.5V	
13Z7P5P5TO	Z107,201,202	Zener Diode 7.5V	
13Z8P2P5TO	Z104,105,601,602	Zener Diode 8.2V	
122SC1815	Q103,203,305,601-604	Transistor 2SC1815	
122SC1815	Q105,205,303,402	Transistor 2SC1815	
122SA1015	Q101,201,304	Transistor 2SA1015	
122SA1015	Q104,107,204	Transistor 2SA1015	
122SC3327	Q106,206,306,401,501	Transistor 2SC3327	
122SK170	Q102,202,301,302	FET 2SK170	
11TC9152	IC101,601	I.C. TC-9152	
11TC4053	IC102,602	I.C. TC-4053	
114558DD	IC103-105,303-307	I.C. JRC4558DD	
114558SD	IC106,107,110,311	I.C. JRC4558SD	
11SSM2126A	IC108	I.C. SSM-2126A	
11NE5532	IC111	I.C. NE5532	
11TC9153	IC112,312,401,501	I.C. TC-9153	
11SSM2404P	IC113,302,603	I.C. SSM-2404P	
11YM3248	IC308	I.C. YM3248	
11NE646	IC309	I.C. NE646	
1178LS05	IC310	I.C. 78LS05	
114558SD	IC313,502,503	I.C. JRC4558SD	
11TC4013	IC604,605,607,608	I.C. TC-4013	
11TC4028	IC606	I.C. TC-4028	
115C114E	IC609,610	I.C. 5C114E	
50C3P58	X301	Crystal Oscillator, Ceramic 3.58MHz	
31610KHS	TVR101,201	TVR 6 H-Type 10K	
22SS004	SW601,602	Slide Switch SS004-P022BY-PF8	
Chassis			
55AC0715		AC Socket AC004	   
682SPT22B		AC Cord SPT-2	
682PVDE2B		AC Cord 2P VDE	
70EMUV910	T001	Transformer	
			AH Version AH Version C Version

PACKING DIAGRAM

ITEM	PART NUMBER	NAME	QTY
37	94200540	EPE Bag	1
38	94440570	Polybag Unit	1
39	90PF141	Polyfoam	2
40	91G019NAD	Gift Box	1
41	93NAD910M	Instruction Manual	1
42 *AH		Safety Instruction Sheet (AH)	1
43 *AH		Warranty Card (AH)	1
44	94240400	Polybag Manual	1
45	98RCA09029	RCA/RCA RED/WHT 90cm	1
46	98RCA0904	RCA/RCA YELLOW 90cm	2
47	98RCA0450	RCA/RCA BLK 45cm	1
48	98RCA04529	RCA/RCA RED/WHT 45cm	3
49	94240400	Polybag RCA cables	1
50	55UM3NAD	Battery UM-3	2
51	28KT187NAD	Remote Control KT-187	1
52	4E281NAD	PE bag 80x200mm E281	1

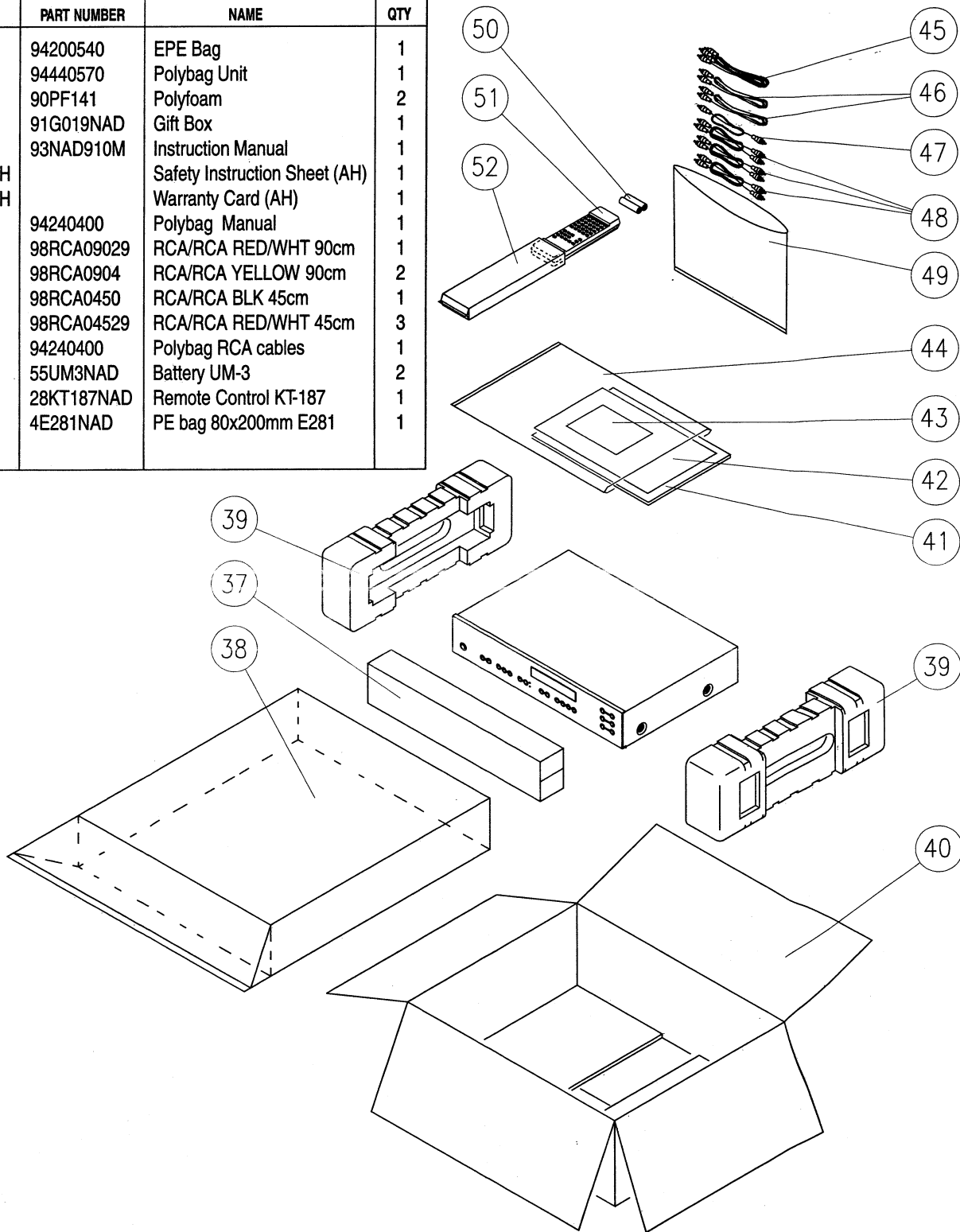

Proprietary information for servicing purposes only. The information herein may not be used commercially without the prior written agreement of NAD Electronics Ltd., London, England.