

C 315BEE

**STEREO
AMPLIFIER**

SERVICE MANUAL

C 315BEE

**STEREO
AMPLIFIER**

NAD

TABLE OF CONTENTS

DESCRIPTION	PAGE
SERVICE CAUTION.....	3-4
REAR PANEL/FRONT PANEL VIEW.....	5
SPECIFICATIONS.....	6
WIRING DIAGRAM.....	7
BLOCK DIAGRAM.....	8-12
ALIGNMENT PROCEDURE.....	13
SCHEMATICS.....	14-16
PCB LAYOUT.....	17-19
TROUBLE SHOOTING GUIDE.....	20
ELECTRICAL PARTS LIST.....	21-27
EXPLODED VIEW.....	28
EXPLODED VIEW PARTS LIST.....	29
PACKING VIEW PARTS LIST.....	30

PRODUCT SAFETY SERVICING GUIDELINES

CAUTION : DO NOT ATTEMPT TO MODIFY THIS PRODUCT IN ANY WAY. NEVER PERFORM CUSTOMIZED INSTALLATIONS WITHOUT MANUFACTURER'S APPROVAL. UNAUTHORIZED MODIFICATIONS WILL NOT ONLY VOID THE WARRANTY, BUT MAY LEAD TO YOUR BEING LIABLE FOR ANY RESULTING PROPERTY DAMAGE OR USER INJURY.

SERVICE WORK SHOULD BE PERFORMED ONLY AFTER YOU ARE THOROUGHLY FAMILIAR WITH ALL OF THE FOLLOWING SAFETY CHECKS AND SERVICING GUIDELINES. TO DO OTHERWISE, INCREASES THE RISK OF POTENTIAL HAZARDS AND INJURY TO THE USER.

WHILE SERVICING, USE AN ISOLATION TRANSFORMER FOR PROTECTION FROM AC LINE SHOCK.

SAFETY CHECKS

AFTER THE ORIGINAL SERVICE PROBLEM HAS BEEN CORRECTED. A CHECK SHOULD BE MADE OF THE FOLLOWING.

SUBJECT : FIRE & SHOCK HAZARD

1. BE SURE THAT ALL COMPONENTS ARE POSITIONED IN SUCH A WAY AS TO AVOID POSSIBILITY OF ADJACENT COMPONENT SHORTS. THIS IS ESPECIALLY IMPORTANT ON THOSE MODULES WHICH ARE TRANSPORTED TO AND FROM THE REPAIR SHOP.
2. NEVER RELEASE A REPAIR UNLESS ALL PROTECTIVE DEVICES SUCH AS INSULATORS, BARRIERS, COVERS, SHIELDS, STRAIN RELIEFS, POWER SUPPLY CORDS, AND OTHER HARDWARE HAVE BEEN REINSTALLED PER ORIGINAL DESIGN. BE SURE THAT THE SAFETY PURPOSE OF THE POLARIZED LINE PLUG HAS NOT BEEN DEFEATED.
3. SOLDERING MUST BE INSPECTED TO DISCOVER POSSIBLE COLD SOLDER JOINTS, SOLDER SPLASHES OR SHARP SOLDER POINTS. BE CERTAIN TO REMOVE ALL LOOSE FOREIGN PARTICLES.
4. CHECK FOR PHYSICAL EVIDENCE OF DAMAGE OR DETERIORATION TO PARTS AND COMPONENTS. FOR FRAYED LEADS, DAMAGED INSULATION (INCLUDING AC CORD). AND REPLACE IF NECESSARY FOLLOW ORIGINAL LAYOUT, LEAD LENGTH AND DRESS.
5. NO LEAD OR COMPONENT SHOULD TOUCH A RECEIVING TUBE OR A RESISTOR RATED AT 1 WATT OR MORE. LEAD TENSION AROUND PROTRUDING METAL SURFACES MUST BE AVOIDED.
6. ALL CRITICAL COMPONENTS SUCH AS FUSES, FLAMEPROOF RESISTORS, CAPACITORS, ETC. MUST BE REPLACED WITH EXACT FACTORY TYPES, DO NOT USE REPLACEMENT COMPONENTS OTHER THAN THOSE SPECIFIED OR MAKE UNRECOMMENDED CIRCUIT MODIFICATIONS.
7. AFTER RE-ASSEMBLY OF THE SET ALWAYS PERFORM AN AC LEAKAGE TEST ON ALL EXPOSED METALLIC PARTS OF THE CABINET, (THE CHANNEL SELECTOR KNOB, ANTENNA TERMINALS. HANDLE AND SCREWS) TO BE SURE THE SET IS SAFET TO OPERATE WITHOUT DANGER OF ELECTRICAL SHOCK. DO NOT USE A LINE ISOLATION TRANSFORMER DURING THIS TEST USE AN AC VOLTMETER, HAVING 5000 OHMS PER VOLT OR MORE SENSITIVITY, IN THE FOLLOWING MANNER; CONNECT A 1500 OHM 10 WATT RESISTOR, PARALLELED BY A .15 MFD, 150V AC TYPE CAPACITOR BETWEEN A KNOWN GOOD EARTH GROUND (WATER PIPE, CONDUIT, ETC.) AND THE EXPOSED METALLIC PARTS, ONE AT A TIME.
MEASURE THE AC VOLTAGE ACROSS THE COMBINATION OF 1500 OHM RESISTOR AND .15 MFD CAPACITOR.
REVERSE THE AC PLUG AND REPEAT AC VOLTAGE MEASUREMENTS FOR EACH EXPOSED METALLIC PART.

VOLTAGE MEASURE MUST NOT EXCEED 75 VOLTS R.M.S. THIS CORRESPONDS TO 0.5 MILLIAMPS AC ANY VALUE EXCEEDING THIS LIMIT CONSTITUTES A POTENTIAL SHOCK HAZARD AND MUST BE CORRECTED IMMEDIATELY.

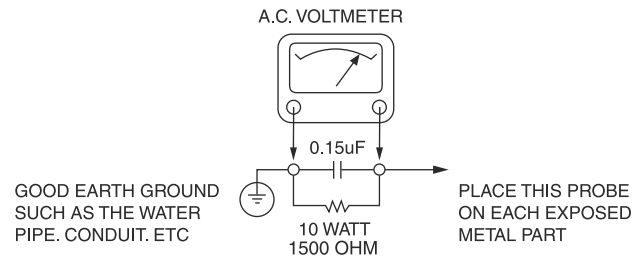

SUBJECT : GRAPHIC SYMBOLS



THE LIGHTNING FLASH WITH ARROWHEAD SYMBOL, WITHIN AN EQUILATERAL TRIANGLE, IS INTENDED TO ALERT THE USER TO THE PRESENCE OF UNINSULATED "DANGEROUS VOLTAGE" WITHIN THE PRODUCT'S ENCLOSURE THAT MAY BE OF SUFFICIENT MAGNITUDE TO CONSTITUTE A RISK OF ELECTRIC SHOCK.



THE EXCLAMATION POINT WITHIN AN EQUILATERAL TRIANGLE IS INTENDED TO ALERT THE USER TO THE PRESENCE OF IMPORTANT OPERATING AND MAINTENANCE (SERVICING) INSTRUCTIONS IN THE LITERATURE ACCOMPANYING THE APPLIANCE.

SUBJECT : TIPS ON PROPER INSTALLATION

1. NEVER INSTALL ANY PRODUCT IN A CLOSED-IN RECESS, CUBBYHOLE OR CLOSELY FITTING SHELF SPACE. OVER OR CLOSE TO HEAT DUCT, OR IN THE PATH OF HEATED AIR FLOW.
2. AVOID CONDITIONS OF HIGH HUMIDITY SUCH AS: OUTDOOR PATIO INSTALLATIONS WHERE DEW IS A FACTOR, NEAR STEAM RADIATORS WHERE STEAM LEAKAGE IS A FACTOR, ETC.
3. AVOID PLACEMENT WHERE DRAPERIES MAY OBSTRUCT REAR VENTING. THE CUSTOMER SHOULD ALSO AVOID THE USE OF DECORATIVE SCARVES OR OTHER COVERINGS WHICH MIGHT OBSTRUCT VENTILATION.
4. WALL AND SHELF MOUNTED INSTALLATIONS USING A COMMERCIAL MOUNTING KIT MUST FOLLOW THE FACTORY APPROVED MOUNTING INSTRUCTIONS A PRODUCT MOUNTED TO A SHELF OR PLATFORM MUST RETAIN ITS ORIGINAL FEET (OR THE EQUIVALENT THICKNESS IN SPACERS) TO PROVIDE ADEQUATE AIR FLOW ACROSS THE BOTTOM, BOLTS OR SCREWS USED FOR FASTENERS MUST NOT TOUCH ANY PARTS OR WIRING. PERFORM LEAKAGE TEST ON CUSTOMIZED INSTALLATIONS.
5. CAUTION CUSTOMERS AGAINST THE MOUNTING OF A PRODUCT ON SLOPING SHELF OR A TILTED POSITION, UNLESS THE PRODUCT IS PROPERLY SECURED.
6. A PRODUCT ON A ROLL-ABOUT CART SHOULD BE STABLE ON ITS MOUNTING TO THE CART. CAUTION THE CUSTOMER ON THE HAZARDS OF TRYING TO ROLL A CART WITH SMALL CASTERS ACROSS THRESHOLDS OR DEEP PILE CARPETS.
7. CAUTION CUSTOMERS AGAINST THE USE OF A CART OR STAND WHICH HAS NOT BEEN LISTED BY UNDERWRITERS LABORATORIES, INC. FOR USE WITH THEIR SPECIFIC MODEL OF TELEVISION RECEIVER OR GENERICALLY APPROVED FOR USE WITH T.V.'S OF THE SAME OR LARGER SCREEN SIZE.
8. CAUTION CUSTOMERS AGAINST THE USE OF EXTENSION CORDS, EXPLAIN THAT A FOREST OF EXTENSIONS SPROUTING FROM A SINGLE OUTLET CAN LEAD TO DISASTROUS CONSEQUENCES TO HOME AND FAMILY.

SERVICING PRECAUTIONS

CAUTION : Before servicing the A/V Receiver covered by this service data and its supplements and addends, read and follow the **SAFETY PRECAUTIONS**. **NOTE** : if unforeseen circumstances create conflict between the following servicing precautions and any of the safety precautions in this publication, always follow the safety precautions.

Remember Safety First:

General Servicing Precautions

1. Always unplug the A/V Receiver AC power cord from the AC power source before:
 - (1) Removing or reinstalling any component, circuit board, module, or any other assembly.
 - (2) Disconnecting or reconnecting any internal electrical plug or other electrical connection.
 - (3) Connecting a test substitute in parallel with an electrolytic capacitor.**Caution** : A wrong part substitution or incorrect polarity installation of electrolytic capacitors may result in an explosion hazard.
2. Do not spray chemicals on or near this A/V Receiver or any of its assemblies.
3. Unless specified otherwise in this service data, clean electrical contacts by applying an appropriate contact cleaning solution to the contacts with a pipe cleaner, cottontipped swab, or comparable soft applicator.
Unless specified otherwise in this service data, lubrication of contacts is not required.
4. Do not defeat any plug/socket B+ voltage interlocks with which instruments covered by this service manual might be equipped.
5. Do not apply AC power to this A/V Receiver and/or any of its electrical assemblies unless all solid-state device heat sinks are correctly installed.
6. Always connect test instrument ground lead to the appropriate ground before connecting the test instrument positive lead. Always remove the test instrument ground lead last.

Insulation Checking Procedure

Disconnect the attachment plug from the AC outlet and turn the power on. Connect an insulation resistance meter(500V) to the blades of the attachment plug. The insulation resistance between each blade of the attachment plug and accessible conductive parts (Note 1) should be more than 1M-ohm.

Note 1 : Accessible Conductive Parts including Metal panels, Input terminals, Earphone jacks, etc.

Electrostatically Sensitive (ES) Devices

Some semiconductor (solid state) devices can be damaged easily by static electricity. Such components commonly are called Electrostatically Sensitive (ES) Devices. Examples of typical Es devices are integrated circuits and some field effect transistors and semiconductor chip components.

The following techniques should be used to help reduce the incidence of component damage caused by static electricity.

1. Immediately before handling any semiconductor component or semiconductor-equipped assembly, drain off any electrostatic charge on your body by touching a known earth ground. Alternatively, obtain and wear a commercially available discharging wrist strap device, which should be removed for potential shock reasons prior to applying power to the unit under test.
2. After removing an electrical assembly equipped with ES devices, place the assembly on a conductive surface such as aluminum foil, to prevent electrostatic charge buildup or exposure of the assembly.
3. Use only a grounded-tip soldering iron to solder or unsolder ES devices.
4. Use only an antistatic solder removal device. Some solder removal devices not classified a "anti-static" can generate electrical charges sufficient to damage ES devices.
5. Do not use freonpropelled chemicals. These can generate electrical charge sufficient to damage ES devices.
6. Do not remove a replacement ES device from its protective package until immediately before you are ready to install it. (Most replacement ES devices are packaged with leads electrically shorted together by conductive foam, aluminum foil, or comparable conductive material).
7. Immediately before removing the protective material from the leads of a replacement ES device, touch the protective material to the chassis or circuit assembly into which the device will be installed.

Caution : Be sure no power is applied to the chassis or circuit, and observe all other safety precautions.

8. Minimize bodily motions when handing unpackaged replacement ES devices. (Normally harmless motion such as the brushing together of your clothes fabric or the lifting of your foot from a carpeted floor can generate static electricity sufficient to damage an ES device.)

FRONT PANEL CONTROLS (FIGURE 1)

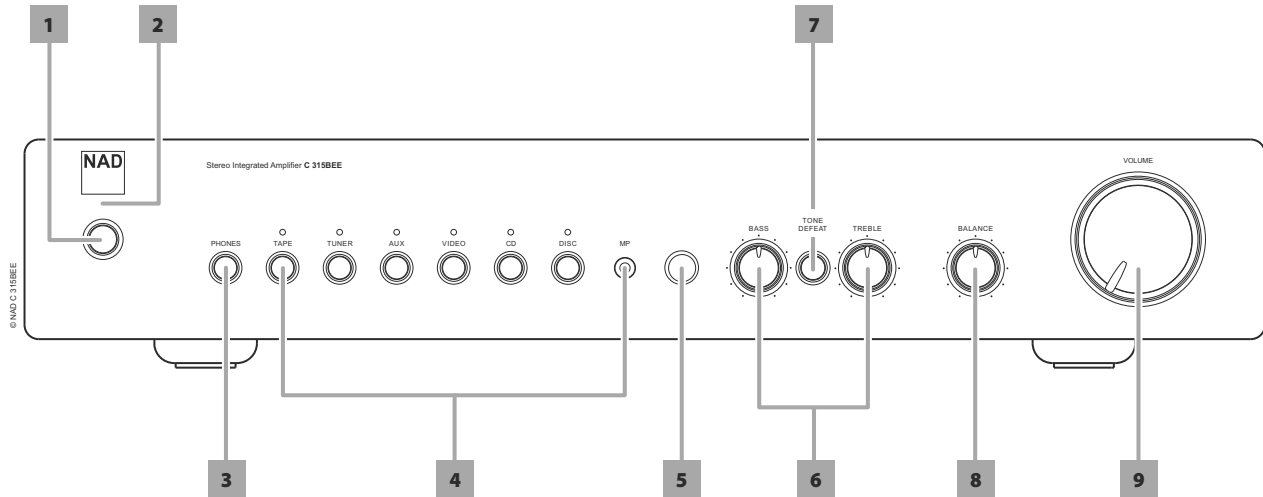

- | | |
|--------------------------------------|--------------------|
| 1. POWER | 5. IR RECEIVER |
| 2. POWER/STAND BY/
PROTECTION LED | 6. TONE CONTROLS |
| 3. HEADPHONE | 7. TONE DEFEAT |
| 4. INPUT SELECTOR | 8. BALANCE CONTROL |
| | 9. VOLUME CONTROL |

REAR PANEL CONNECTIONS (FIGURE 2)

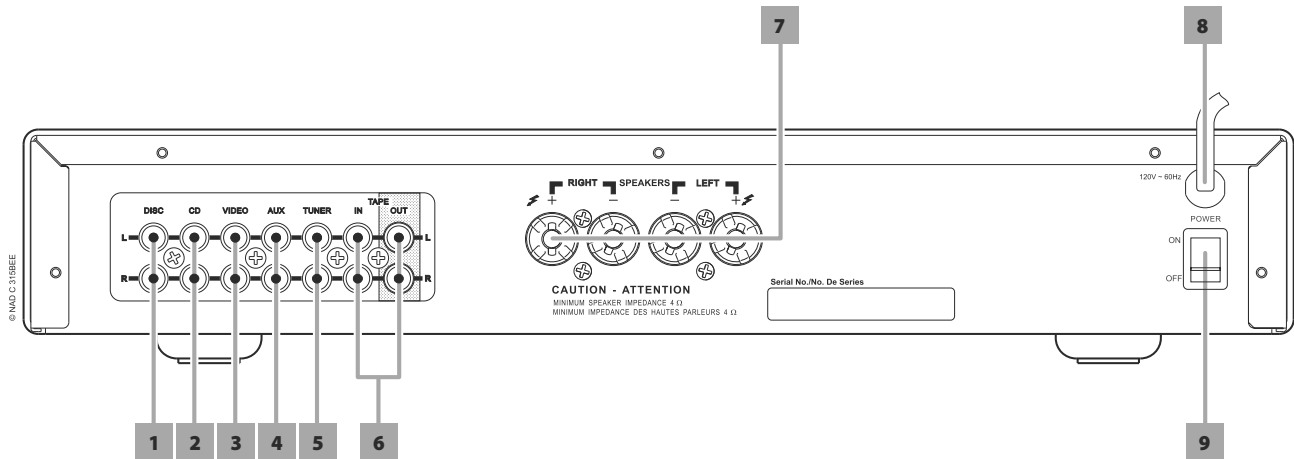

- | | |
|----------------|-----------------|
| 1. DISC INPUT | 6. TAPE IN/OUT |
| 2. CD INPUT | 7. SPEAKERS OUT |
| 3. VIDEO INPUT | 8. AC LINE CORD |
| 4. AUX INPUT | 9. POWER SWITCH |
| 5. TUNER INPUT | |

SPECIFICATIONS

PREAMP IN , SPEAKERS OUT

CONTINUOUS AVERAGE POWER OUTPUT INTO 8 OHMS OR 4 OHMS (Min. power per channel, 20 Hz – 20 kHz, with no more than rated distortion)	40 W (16 dBW)
THD + Noise	< 0.02%
Clipping power (maximum continuous power per channel 4 and 8).	45 W
IHF dynamic headroom: at 8 ohms at 4 ohms	+ 3.6 dB + 4.8 dB
IHF dynamic power (maximum short term power per channel) 8 ohms: 4 ohms: 2 ohms:	90W (19.5 dBW) 120W (20.8 dBW) 170 W (22.3 dBW)
Damping factor (ref. 8 ohms 1 kHz)	> 200
Input Impedance	R = 50 kohms C = 100pF
Input sensitivity (for rated output into 8 ohms)	200 mV
Voltage gain	39 dB
Frequency response 20 Hz – 20 kHz	<+/-1.0 dB (tone defeat off) <+/-0.2dB (tone defeat on)
Signal / Noise ratio , A-weighted	95dB ref. 1 W 111dB ref. 40 W
SMPTE I.M. (Intermodulation Distortion, 60 Hz + 7 kHz, 4:1, from 250 mW to rated output)	< 0.02%
IHF I.M. (CCIF IM Distortion, 19 + 20 kHz at rated output)	< 0.01%
Headphones Output Impedance	68 ohms
Maximum input signal	7 V
CONTROLS	
Treble	+/- 5 dB at 10 kHz
Bass	+/- 8 dB at 100 Hz
DIMENSIONS AND WEIGHTS	
	Net Weight
	Shipping Weight
DIMENSION (WHD)	
	5.25 kg (11.5 lb)
	6.5 kg (14.3lb)
	435 X70 X 242mm

WIRING DIAGRAM

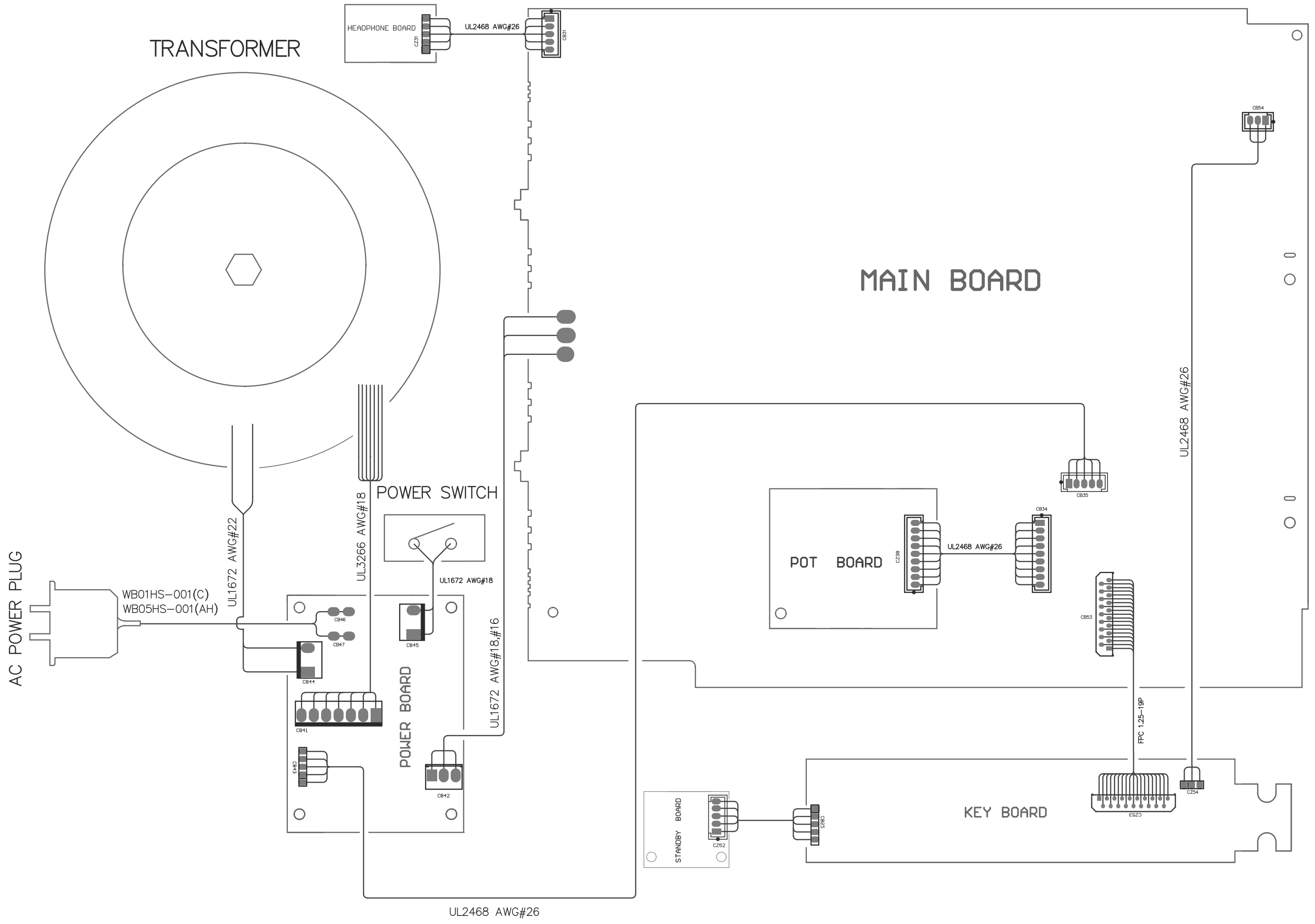

BLOCK DIAGRAM

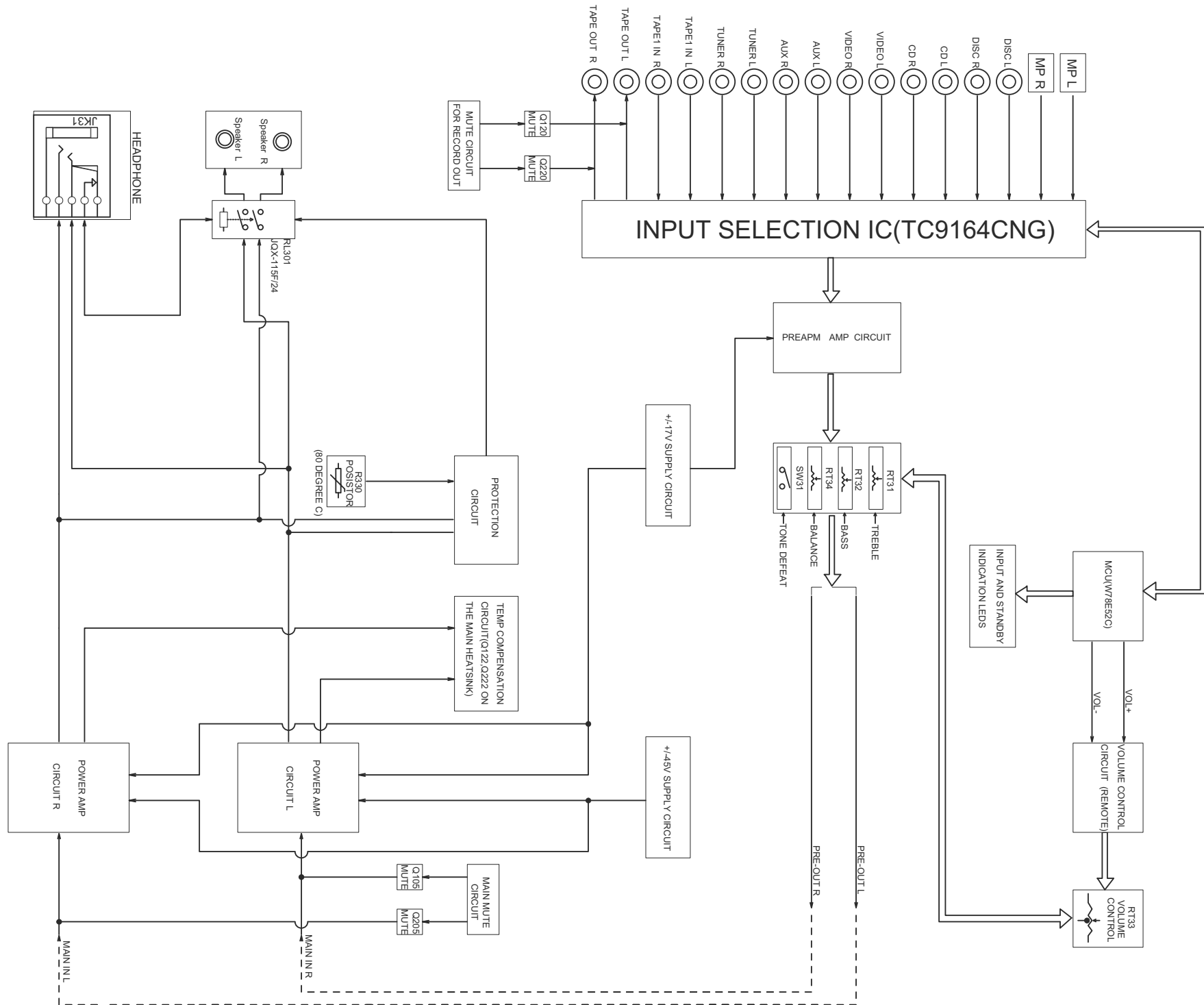

MICROPROCESSOR CONNECTION DIAGRAM

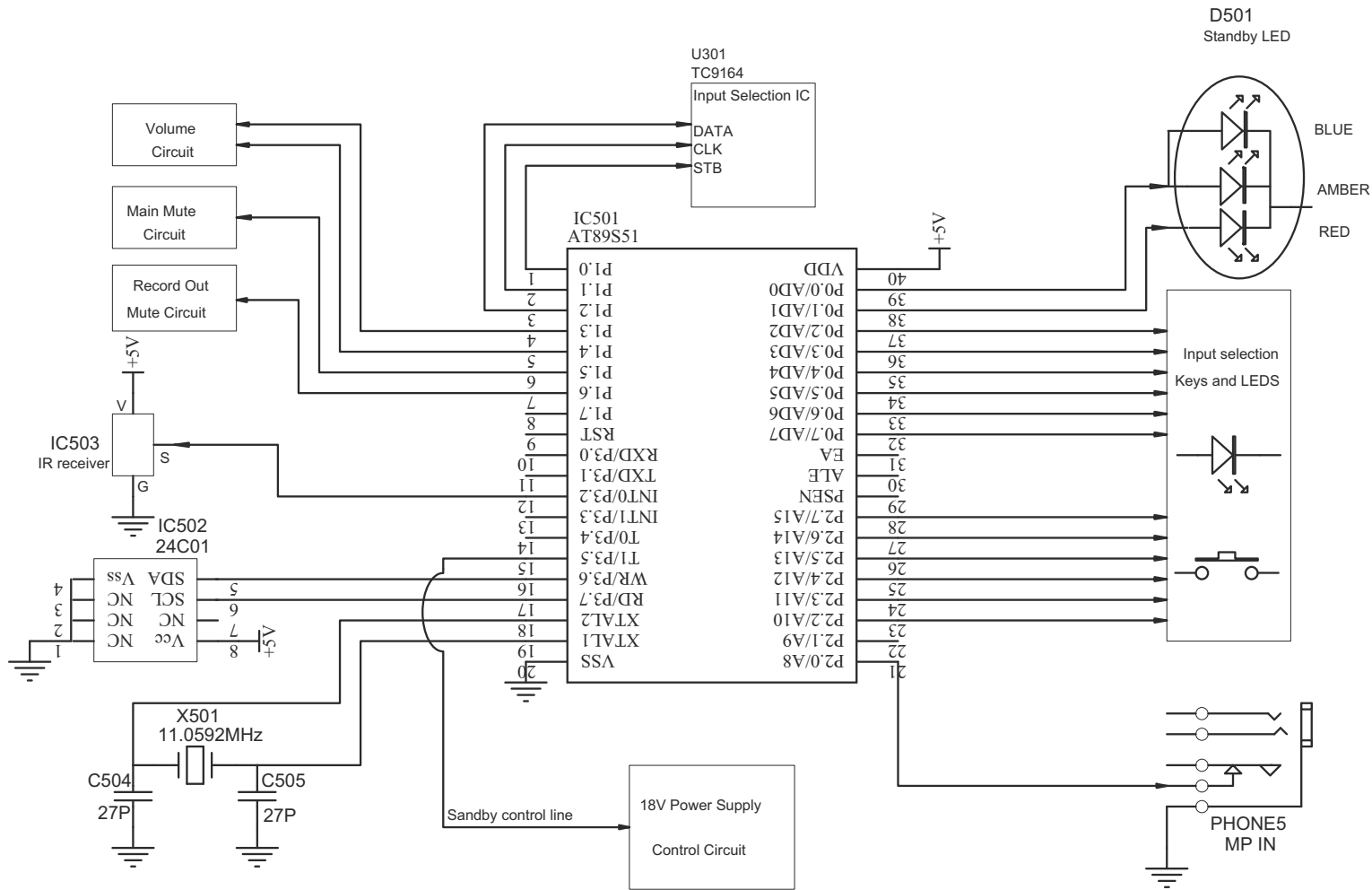

24C01

KEY BOARD: IC502

PIN CONFIGURATION

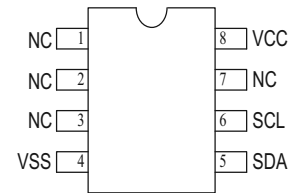

FUNCTIONAL BLOCK DIAGRAM

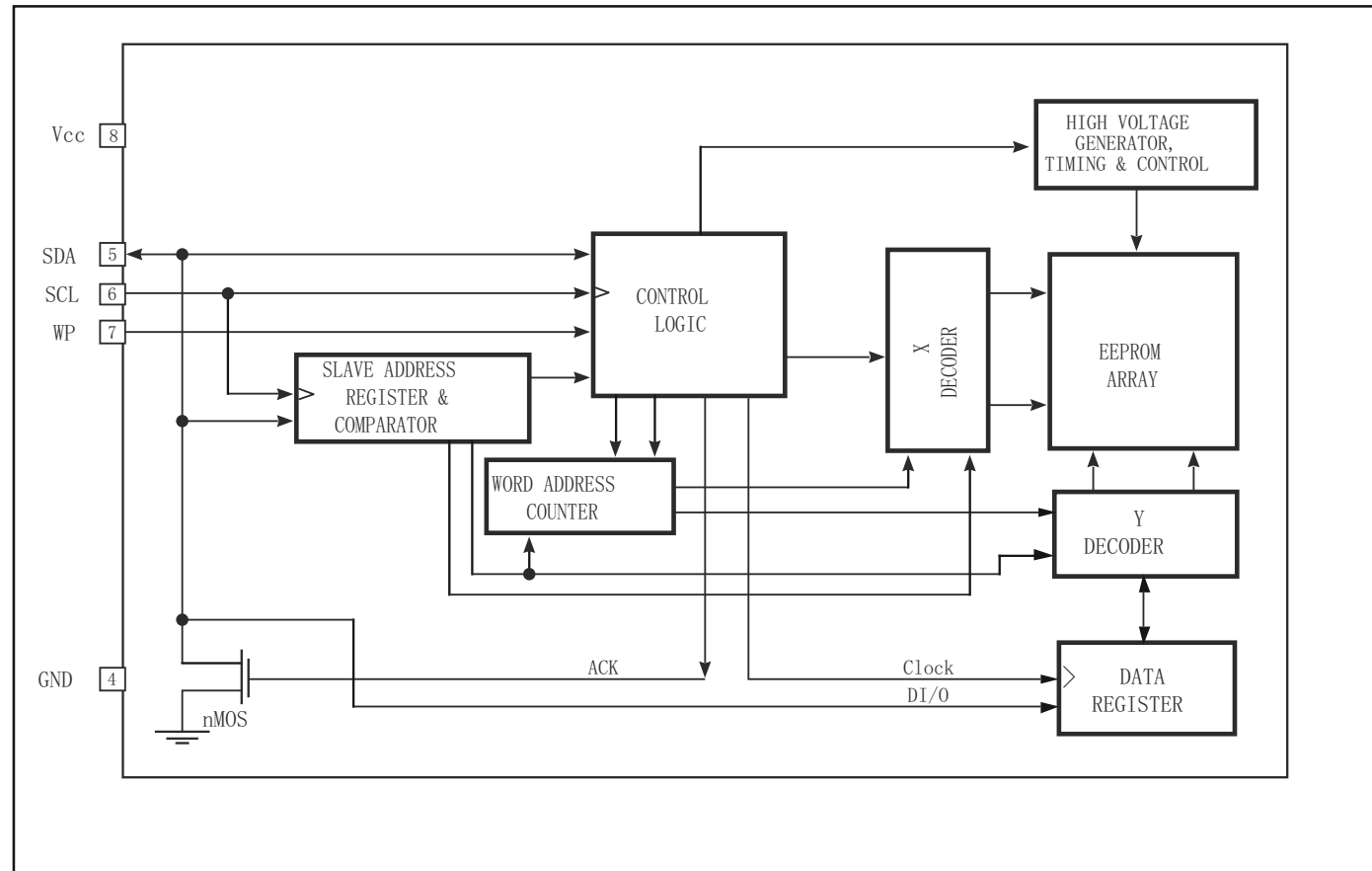

AT89S51/W78E052C
 MAIN BOARD : IC501

PIN CONFIGURATION

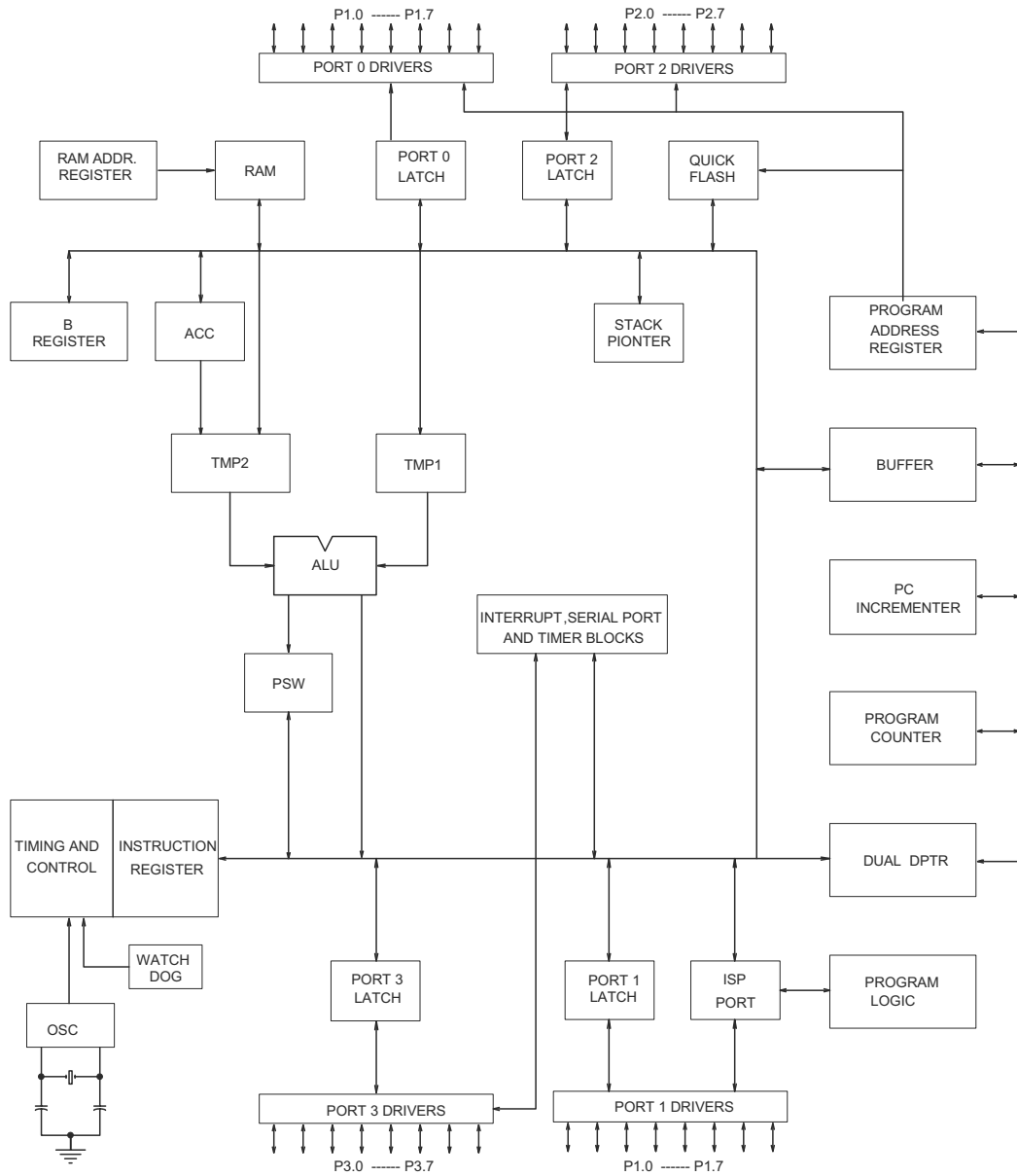
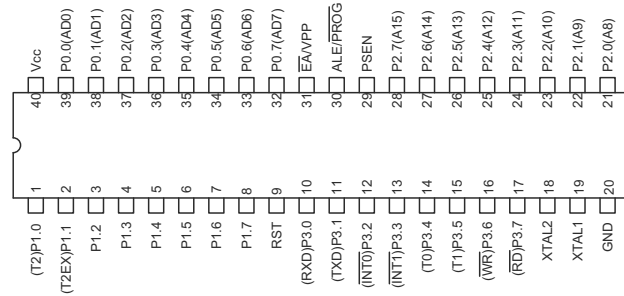

TC9164CNG
MAIN BOARD:U301

PIN CONFIGURATION

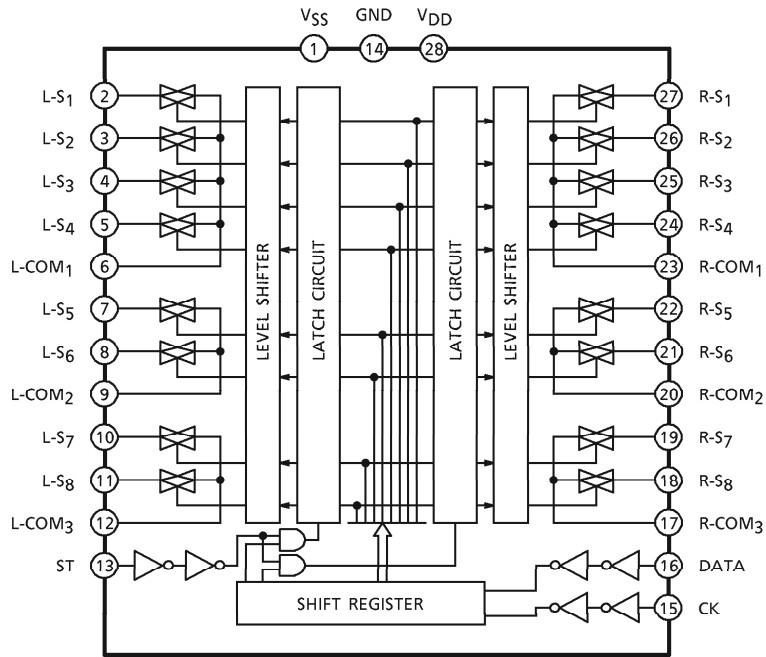
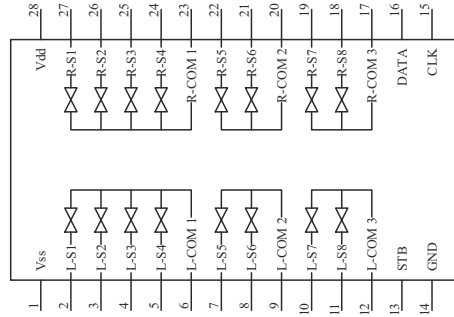

ALIGNMENT PROCEDURES

A. LOWEST VOLUME ADJUSTMENT

1. Turn down the volume potentiometer to the lowest setting.
2. Input a high voltage signal such as 5V from CD input.
3. Connect a oscilloscope to Left channel binding posts.
4. Observing the oscilloscope, adjust VR 102, to make the output of speaker the lowest level possible.
5. Connect a oscilloscope to Right channel binding posts.
5. Adjust VR202 as in line #4 above, to make the output of the speaker the lowest level possible.

B. IDLING CURRENT

1. Connect the DMM to TP1 & TP2 as well as TP3 & TP4, adjust the idle current to 12.5mV via VR201/101.
2. Place the top cover back on the unit and let unit run idle for 10 minutes (no input signal nor load).
3. Connect the DMM to TP1 & TP2, adjust VR 101 and then fine adjust VR103 for 7mV +/- 1mV.
4. Connect the DMM to TP3 & TP4, adjust VR201 and then fine adjust VR203 for 7mV +/- 1mV.
5. Install the top cover.

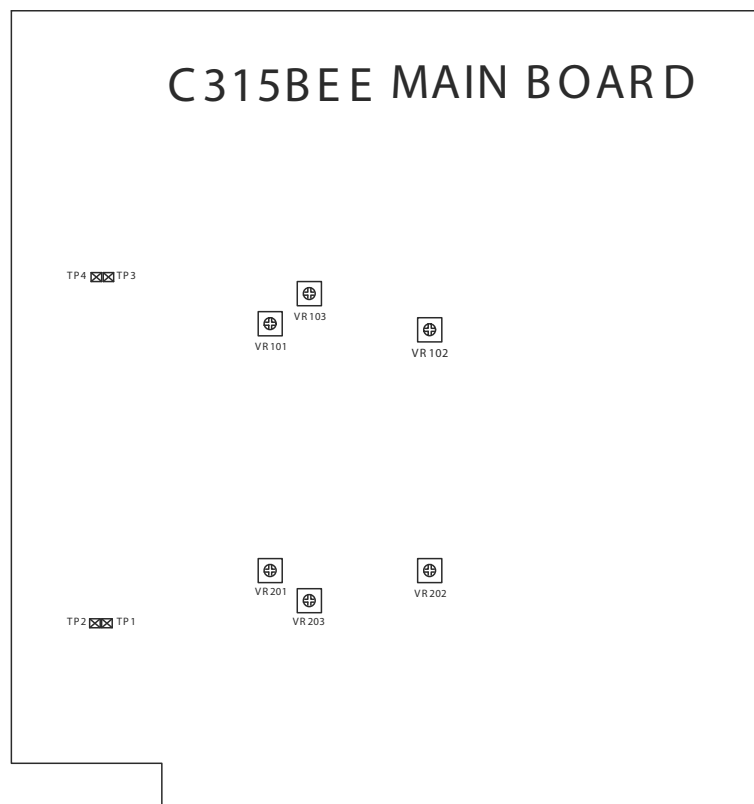

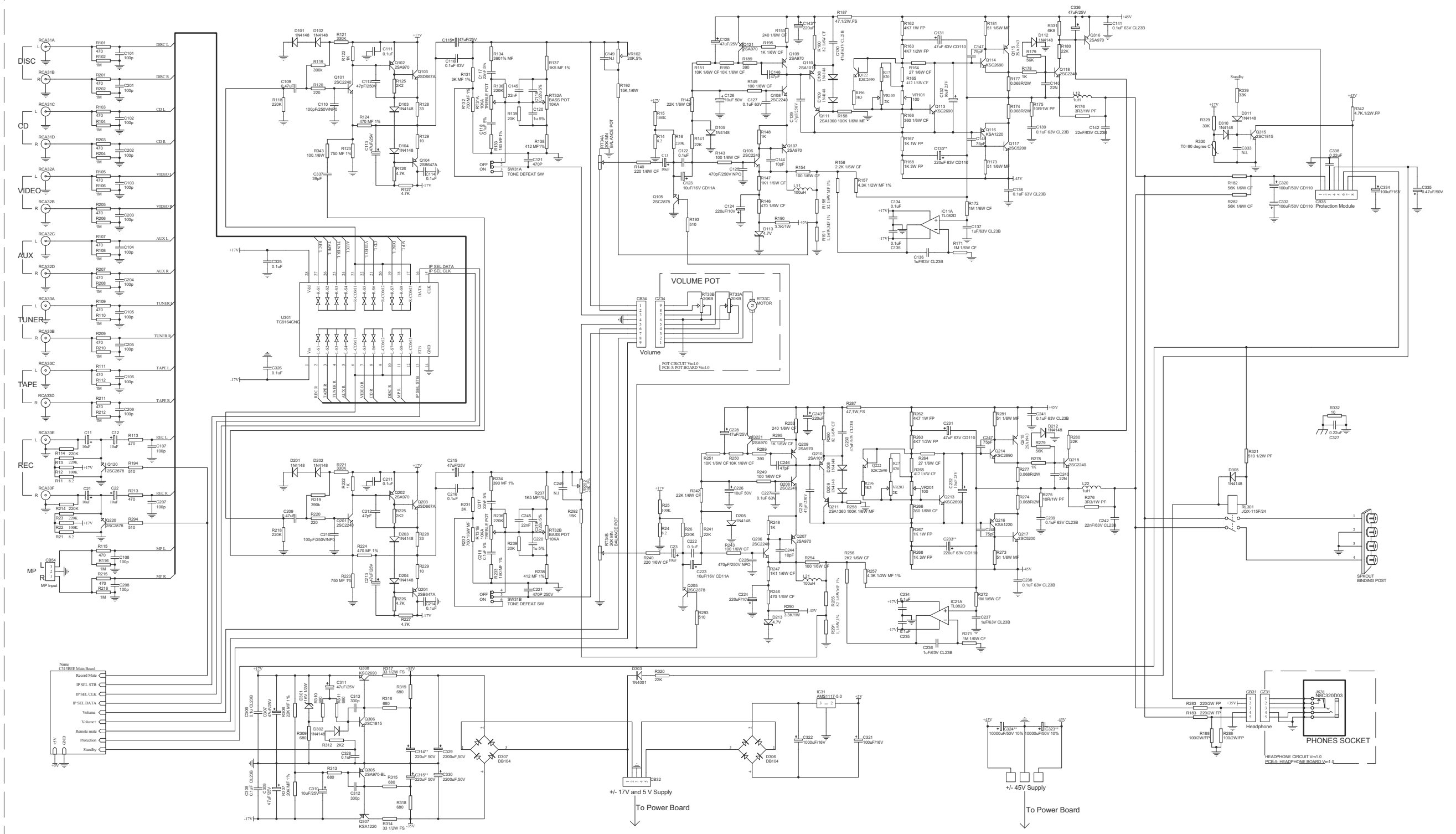

** For countries with higher than expected mains voltage, one may change C323 and C324 from LP 10000uF 50V 85°C 10% (P/N 06-10351-04) to HP 10000uF 63V 105°C +/-10% (P/N 06-10361-00), and change C133, C143, C233, C243, C314 and C315 from CD110 220uF 63V 85°C ±20% (P/N 06-22161-00) to CD263 220uF 63V 105°C ±20% (P/N 06-22161-01).

REV.	DESCRIPTION	Date	APPRO.
Vm1.0	Change C327 to 0.22uF		
Vm1.0	Change R330 to 80 degree		
Vm1.0	Change R329 to 30K		
Vm1.1	Add R332		
Vm1.2	Change R165,R265 to 412 from 390		
Vm1.3	Change R147,R247 to 1.1k		

NAD

THE INFORMATION CONTAINED IN THIS DRAWING IS THE SOLE PROPERTY OF NAD ELECTRONICS INTL.. ANY REPRODUCTION IN PART OF WHOLE WITHOUT THE WRITTEN PERMISSION OF NAD ELECTRONICS INTL. IS PROHIBITED

Document Number: HS4_C315BEE_B007_Vm1.3_AMP.SCH	Sheet: 1 / 3
Project: C315BEE	State: Vm
Drawn by:	PL Checked by:
Date:	PTA Checked by:
	Approved by:
	Date:

SCHEMATICS DIAGRAM (2/3)

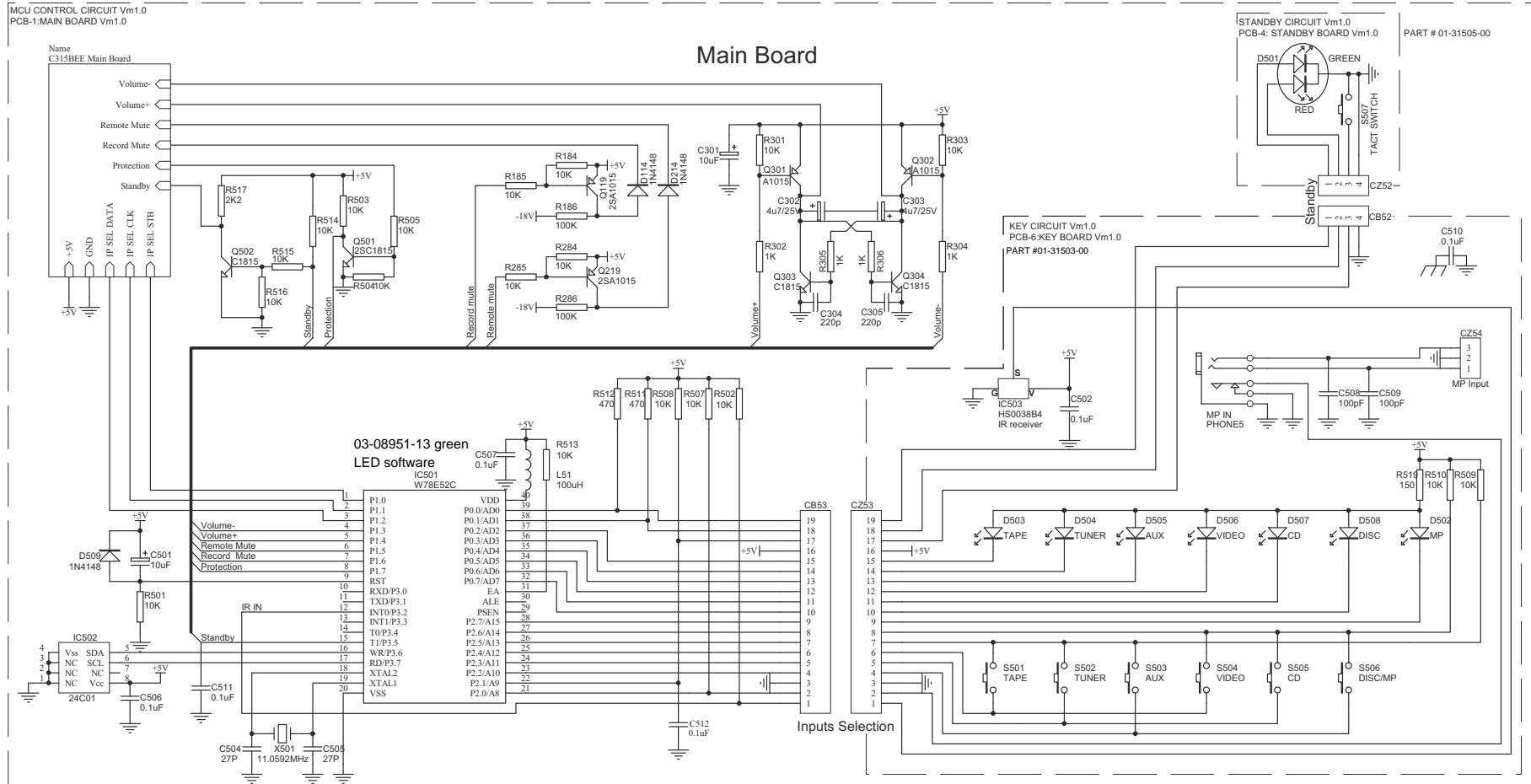

DESCRIPTION	Date	APPRO	NAD	
Add C510,C511,C512			THE INFORMATION CONTAINED IN THIS DRAWING IS THE SOLE PROPERTY OF NAD ELECTRONICS INTL. ANY REPRODUCTION IN PART OF WHOLE WITHOUT THE WRITTEN PERMISSION OF NAD ELECTRONICS INTL IS PROHIBITED.	
			Document Number: HS4_C315BEE_B007_Vm1.0_KEY.SCH	Sheet: 3 / 3
			Project: C315BEE	State: Vm
Drafted by:	PL Checked by:	PTA Checked by:	Approved by:	
Date:	Date:	Date:	Date:	

Main Board

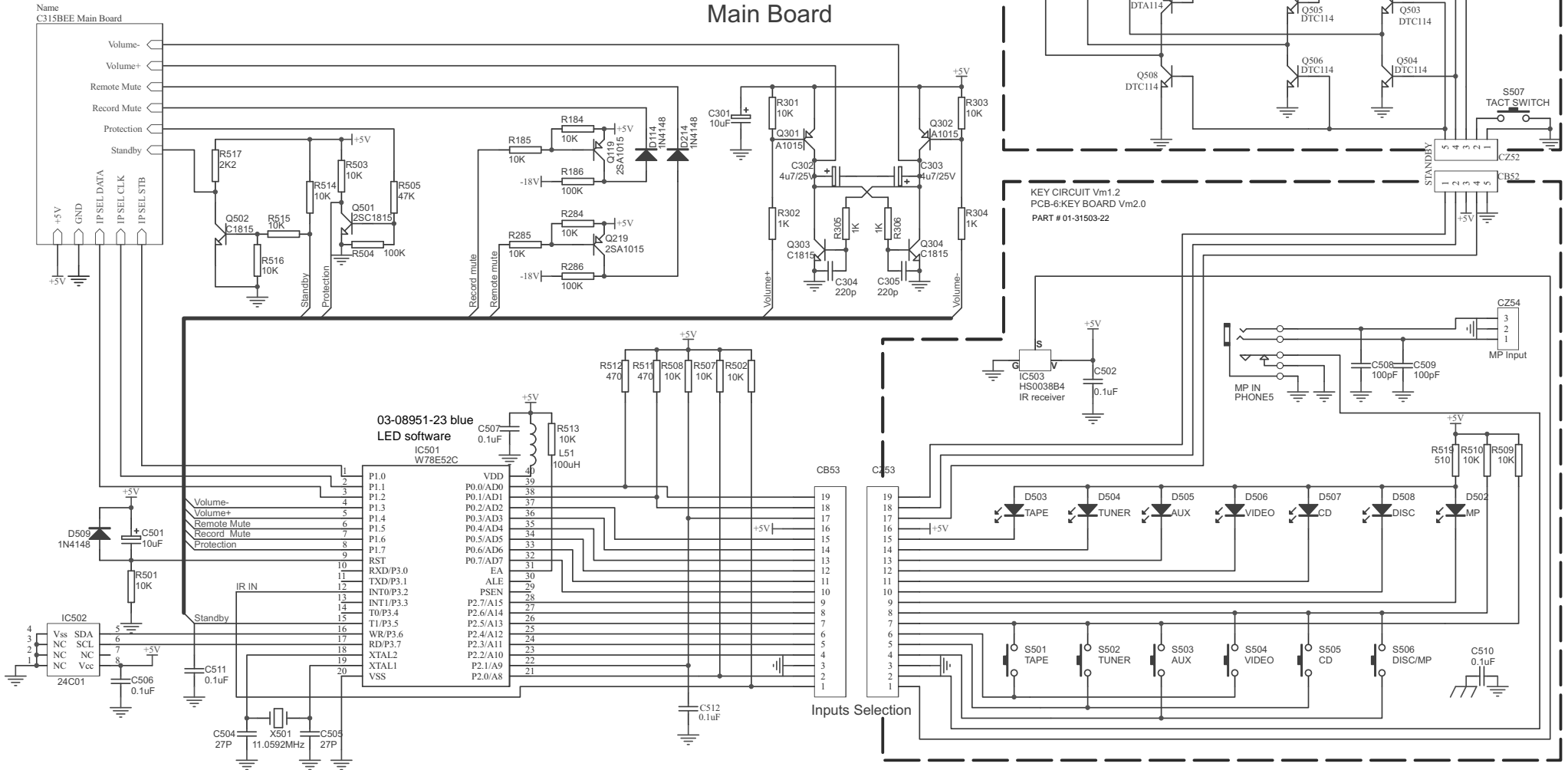

DESCRIPTION	Date	APPRO	NAD
Change LEDs to Blue, change software version from V4.0 to V5.0			
1. Change R519 from 510 ohm to 620 ohm (Input LED).			Document Number: HS4_C315BEE_8007_Vm1.0_KEY.SCH
2. Change R522 from 100 ohm to 220 ohm (Power blue LED).			Sheet: 3 / 3
3. Change R521 from 330 ohm to 470 ohm (Power amber LED).			Project: C315BEE
4. Change R524 from 100 ohm to 330 ohm (Power red LED).			State: Vm
			Drafted by: PL Checked by: PTA Checked by: Approved by:
			Date: Date: Date: Date:

SCHEMATICS DIAGRAM (3/3)

POWER CIRCUIT Vm1.0
PCB-2:POWER BOARD Vm2.0

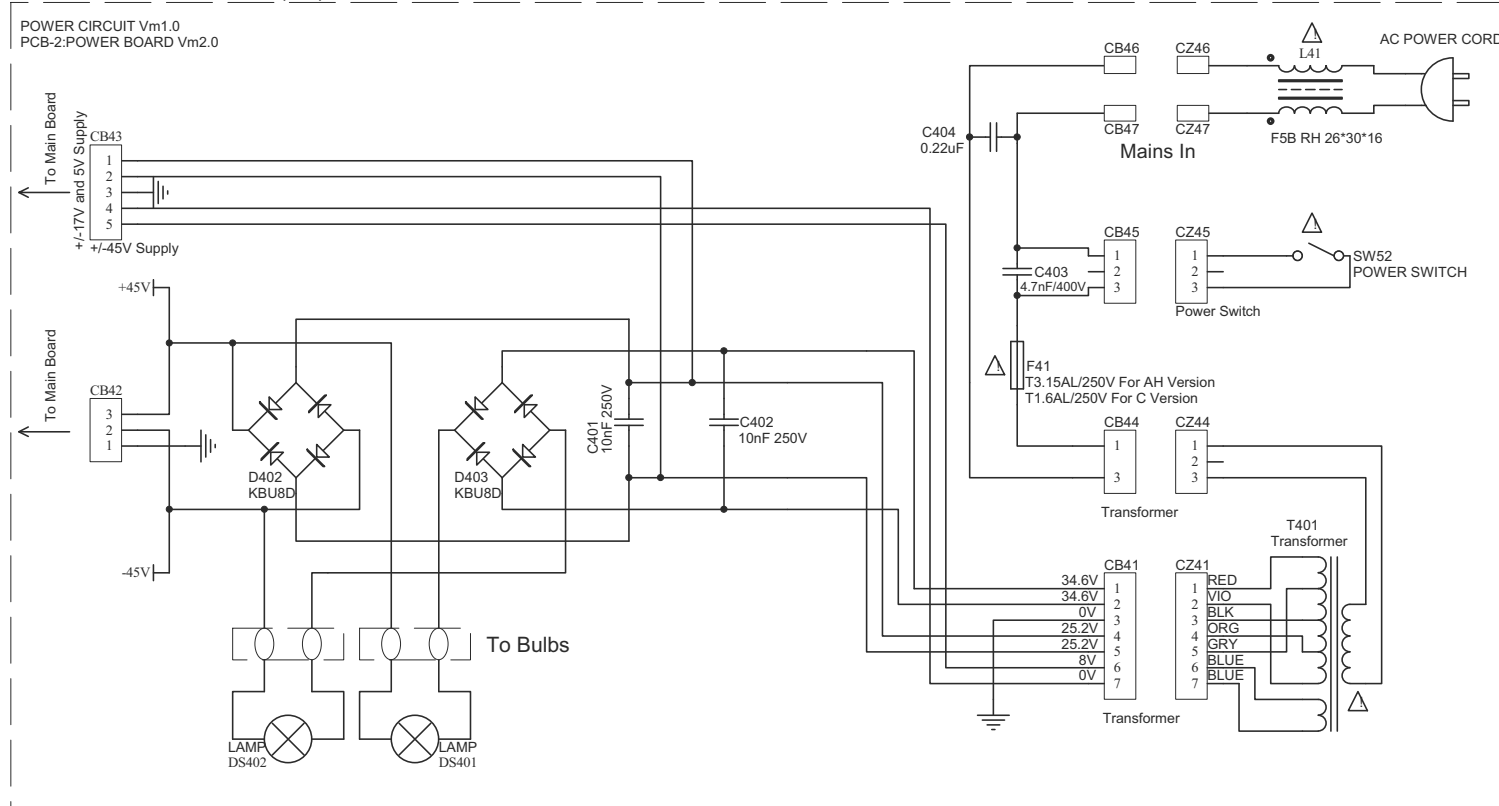

REV	DESCRIPTION	Date	APPRO	NAD			
	Add C404 & L41			THE INFORMATION CONTAINED IN THIS DRAWING IS THE SOLE PROPERTY OF NAD ELECTRONICS INTL.. ANY REPRODUCTION IN PART OF WHOLE WITHOUT THE WRITTEN PERMISSION OF NAD ELECTRONICS INTL. IS PROHIBITED			
				Document Number:	HS4_C315BEE_B007_Vm1.0_POWER.SCH	Sheet:	2 / 3
				Project:	C315BEE	State:	Vm
				Drafted by:	PL Checked by:	PTA Checked by:	Approved by:
				Date:	Date:	Date:	Date:

PCB-2: POWER BOARD Vm2.0

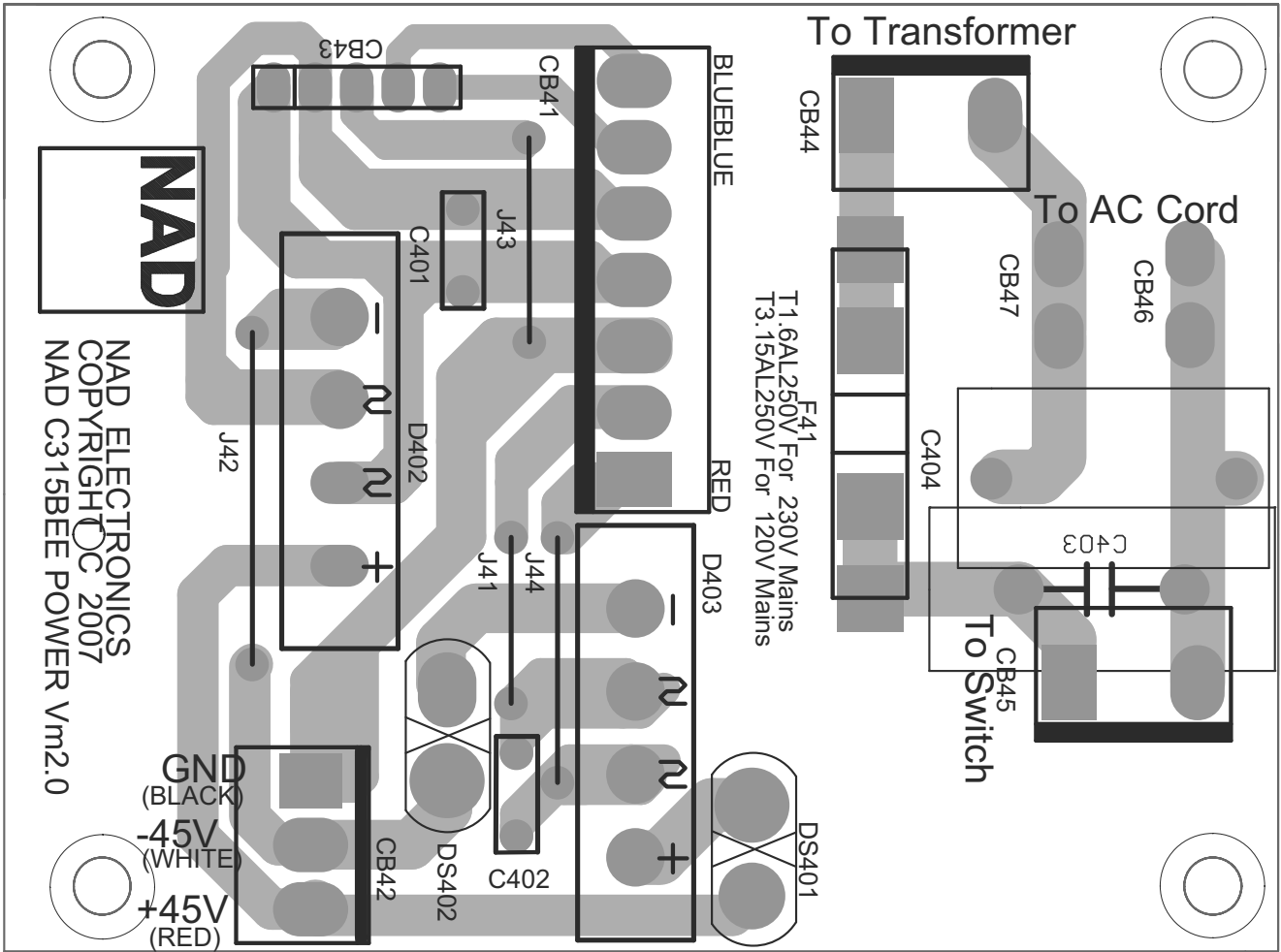

PCB-3: POT BOARD Vm1.0

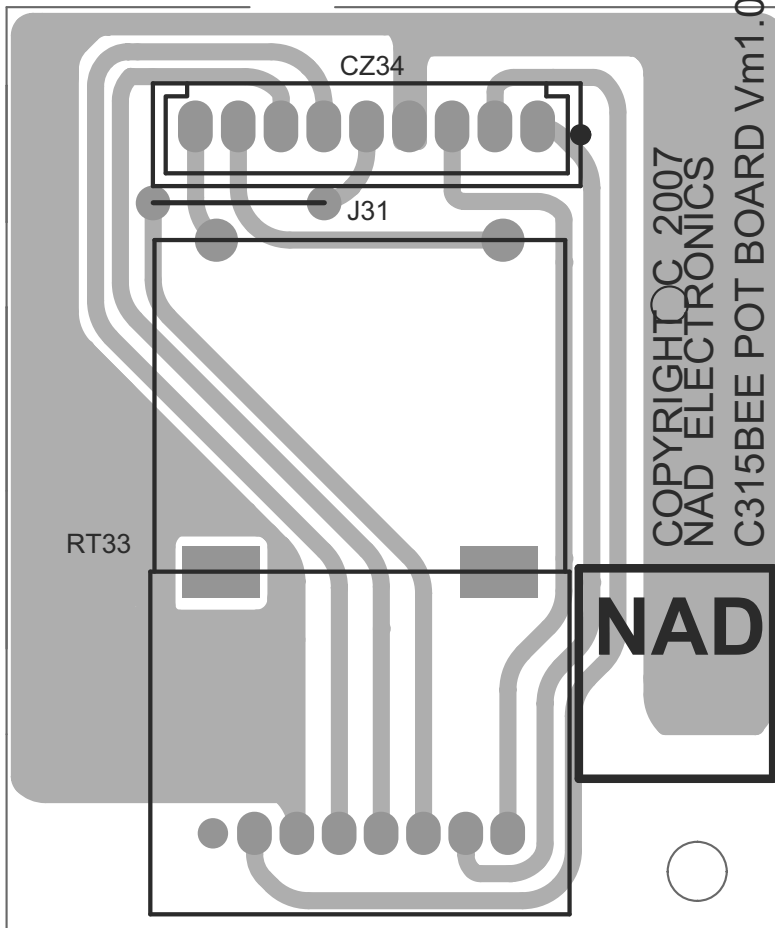

PCB-4: STANDBY BOARD Vm1.0

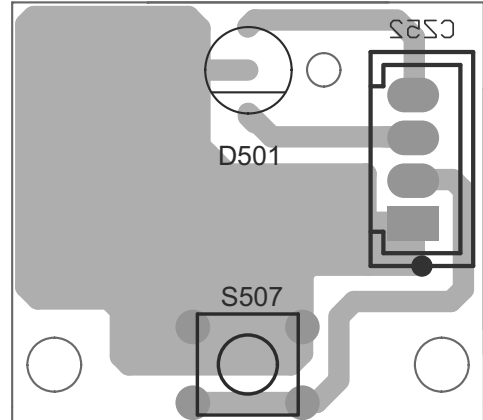

PCB-5: HEADPHONE BOARD Vm1.0

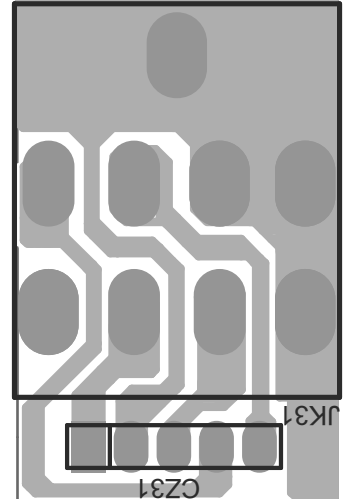

PCB-1: MAIN BOARD Vm1.0

Heatsink Assembly 01-31500-00 : With R330 Q215, Q217, Q115, Q117, Q122

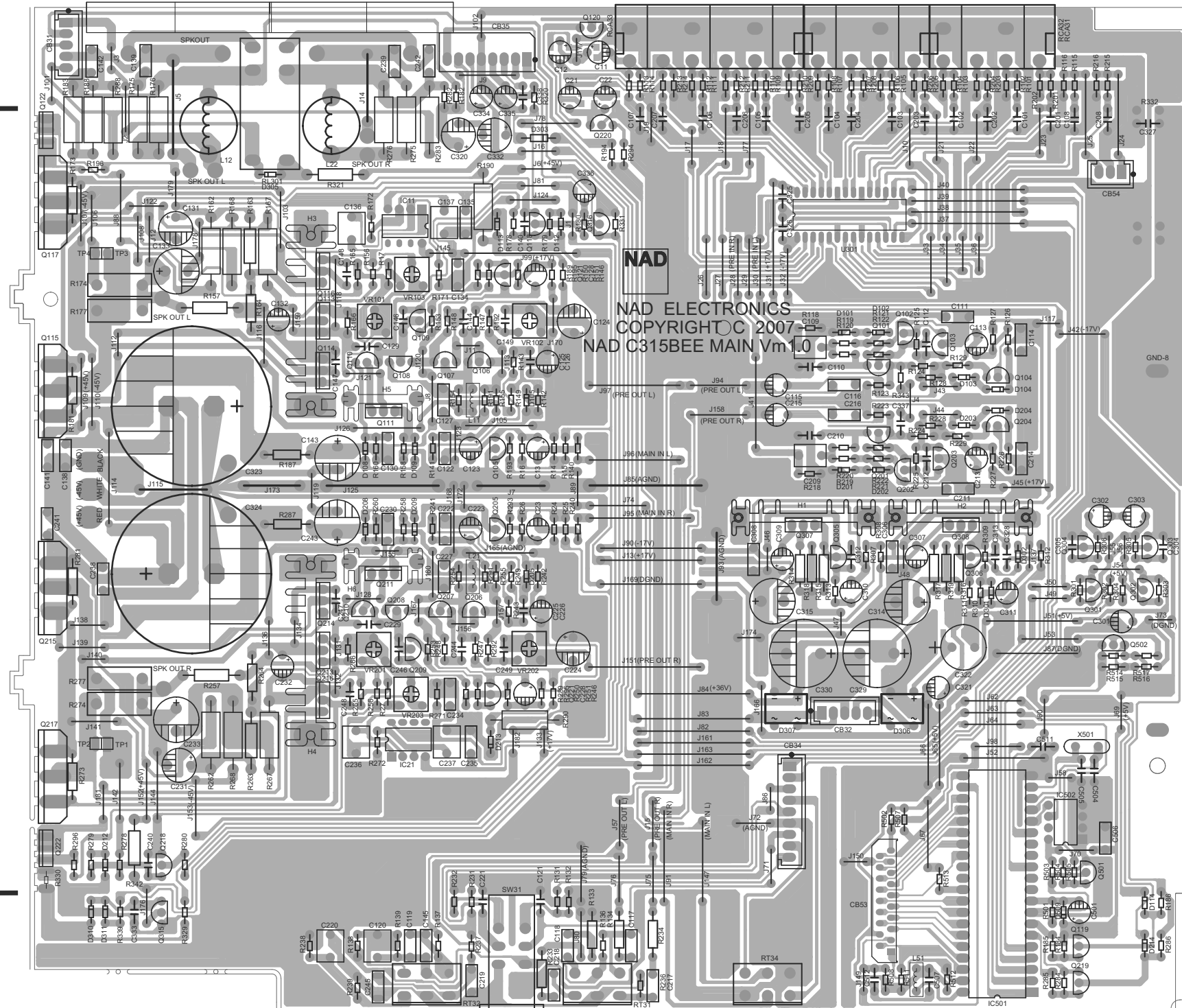

PCB-6: KEY BOARD Vm1.0

(TOP VIEW)

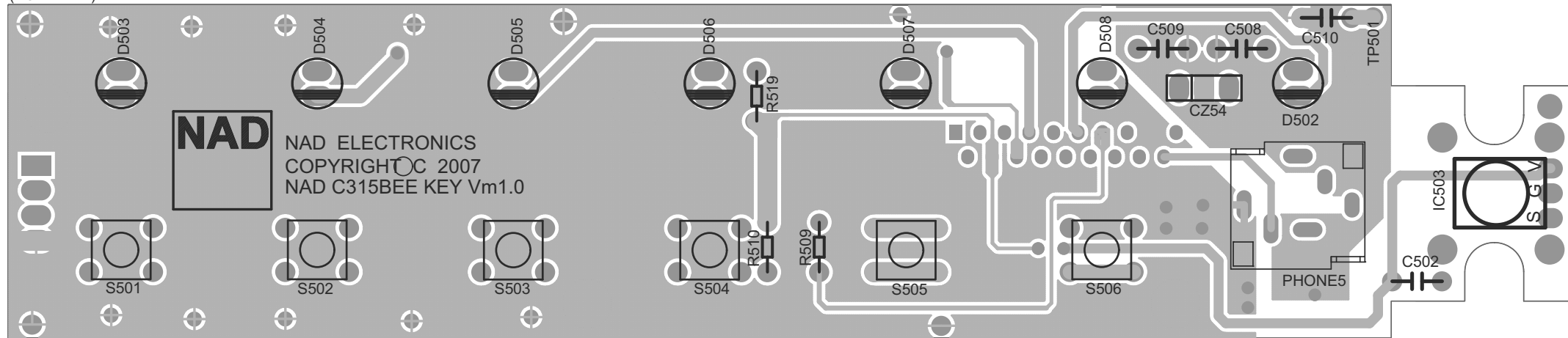

PCB-6: KEY BOARD Vm1.0

(BOTTOM VIEW)

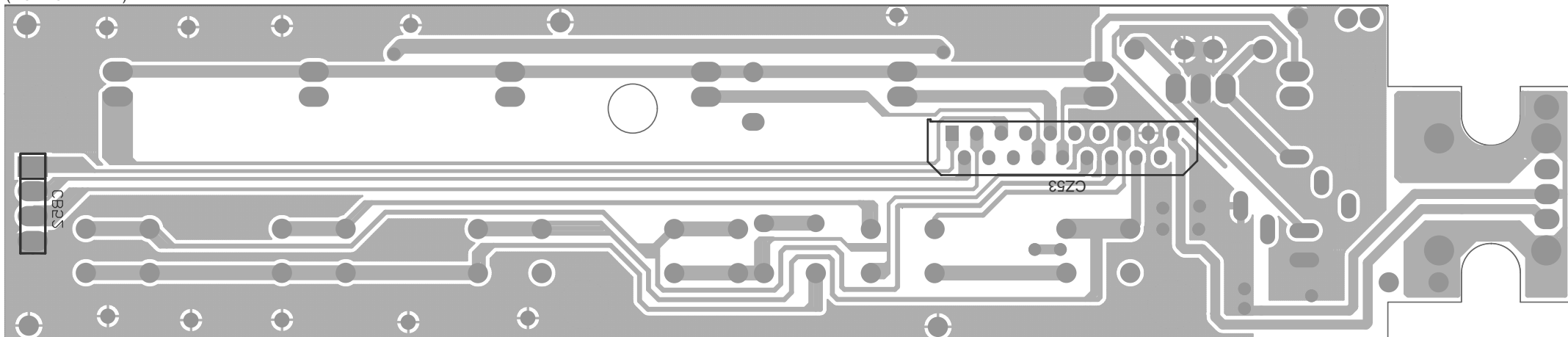

TROUBLESHOOTING GUIDE

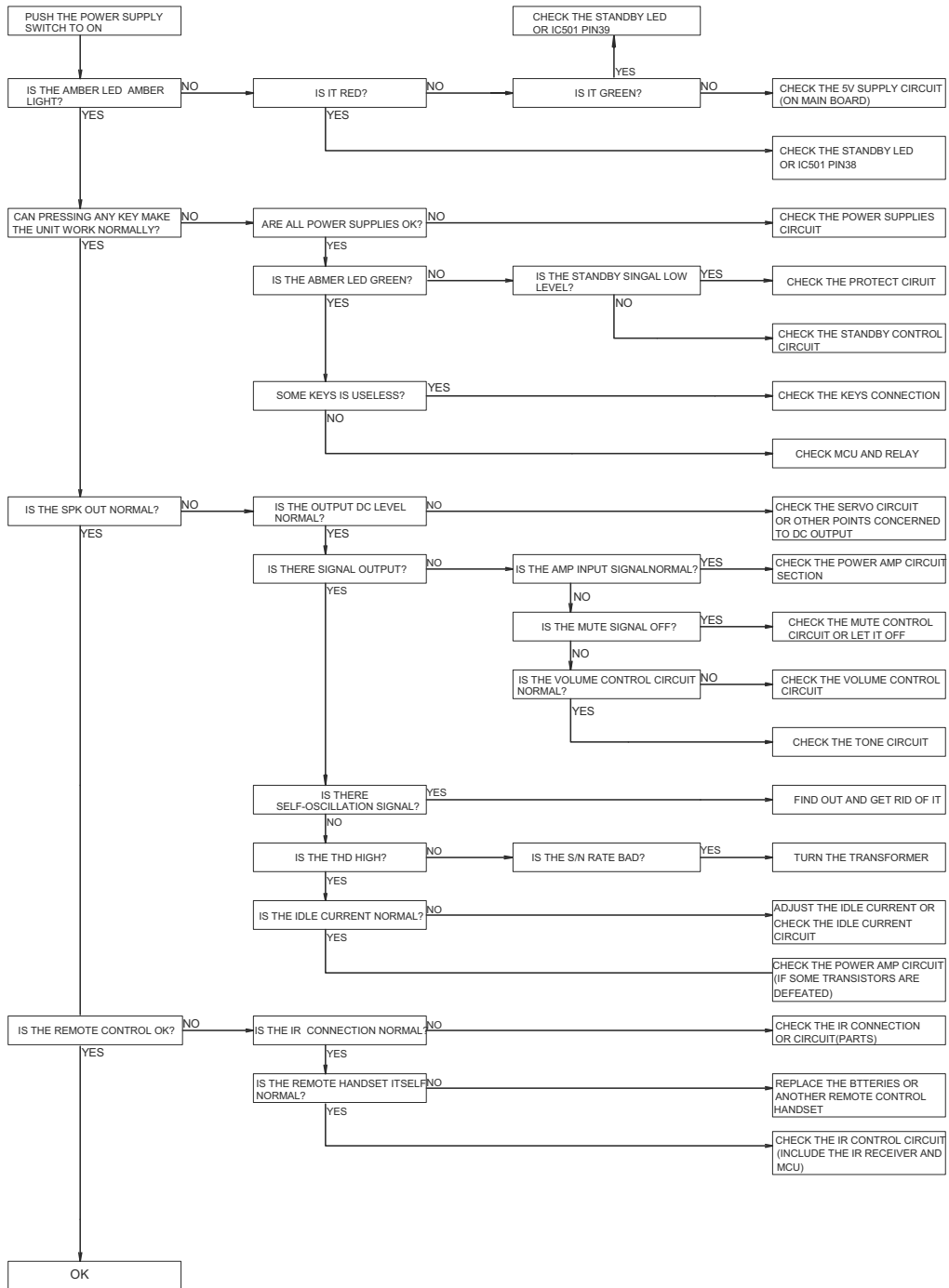

ELECTRIAL PARTS LIST

PCB-1: MAIN BOARD

CIRCUIT NO.	PART NO.	DESCRIPTION
ICS		
IC11, IC21	03-00082-00	TL082CP/CN/D
IC31	03-01117-01	AMS1117-5.0/ LM1117MPX-5.0
IC502	03-02402-00	24C01A/24C02(A)/24C04(A)
U301	03-09164-00	TC9164CNG
IC501	03-08951-13	AT89S51-24PI/ W78E052C40DL Programmed
IC501	03-08951-03	AT89S51-24PI/ W78E052C40DL Unprogrammed
CB35	02-01237-00	upc1237 Protection Module
DIODES		
D101, D102, D103, D104, D105, D108, D109, D112, D114, D201, D202, D203, D204, D205, D208, D209, D212, D214, D302, D305, D310, D311, D509	33-44148-00	1N4148
D113, D213	33-14709-00	4.7V, 0.5W
D301	33-11600-00	16V, 0.5W
D303	33-24001-00	IN4001
D306, D307	33-30142-00	DB104
TRANSISTORS		
Q110, Q119, Q210, Q219, Q301, Q302	31-01015-00	2SA1015 GR
Q303, Q304, Q306, Q315, Q501, Q502	31-01815-00	2SC1815 GR
Q102, Q107, Q109, Q121, Q202, Q207, Q209, Q221, Q316	31-00970-00	2SA970 GR
Q305	31-00970-10	2SA970 BL
Q101, Q106, Q108, Q118 Q201, Q206, Q208, Q218	31-02240-00	2SC2240 GR
Q105, Q120, Q205, Q220	31-02878-00	2SC2878A
Q103, Q203	31-00667-00	2SD667A
Q104, Q204	31-00647-00	2SB647A
Q113, Q114, Q122, Q213, Q214, Q222, Q308	31-02690-00	KSC2690AYSTU
Q116, Q216, Q307	31-01220-00	KSA1220AYSTU
Q111, Q211	31-01360-00	2SA1360-0(Q)
CAPACITORS		
C144, C244	05-10012-00	10p, 100V, ±10%
C504, C505	05-27012-00	27p, 50V, ±10%
C337	05-39012-00	39p, 50V, ±10%
C112, C129, C146, C212, C229, C246	05-47012-00	47p, 100V, ±10%
C147, C148, C247, C248	05-75012-00	75p, 100V, ±10%
C101, C102, C103, C104, C105, C106, C107, C108, C110, C201, C202, C203, C204, C205, C206, C207, C208, C210	05-10151-01	100p, 50V, ±10%
C304, C305	05-22151-01	220p, 50V, ±10%
C312, C313	05-33151-01	330p, 50V, ±10%
C121, C125, C221, C225	05-47112-00	470p, 100V, ±10%
C140, C240	24-22312-04	22n, 100V, ±10%

C134, C135, C234, C235, C325, C326, C328, C506, C507, C511, C512	24-10461-00	0.1uF, 63V, ±20%
C327, C338	24-22461-00	0.22uF, 63V, ±20%
C117, C142, C145, C217, C242, C245	25-22361-05	22n, 63V, ±5%
C130, C230	25-47361-01	47n, 63V, ±5%
C111, C114, C116, C118, C122, C127, C138, C139, C141, C211, C214, C216, C218, C222, C227, C238, C239, C241, C306, C308	25-10461-07	0.1uF, 63V, ±5%
C119, C219	25-22461-02	0.22uF, 63V, ±5%
C109, C209	25-47461-00	0.47uF, 63V, ±5%
C120, C220, C136, C137, C236, C237	25-10561-02	1u, 63V ±5%
C335	06-47851-02	0.47uF, 50V, ±20%
C302, C303	06-47951-00	4.7uF, 50V, ±20%
C123, C126, C223, C132, C226, C232	06-10051-13	10uF, 50V, ±20%
C11, C12, C13, C21, C22, C23, C301, C310, C501	06-10021-07	10uF, 25V, ±20%
C128, C228, C307, C309, C311, C336	06-47021-08	47uF, 25V, ±20%
C113, C115, C213, C215	06-47021-09	47uF, 25V, ±20%
C131, C231	06-47061-00	47uF, 63V, ±20%
C321, C334	06-10111-00	100uF, 16V, ±20%
C320, C332	06-10151-00	100uF, 50V, ±20%
C124, C224	06-22111-00	220uF, 10V, ±20%
C133, C143, C233, C243, C314, C315	06-22161-00	220uF, 63V, ±20%
C322	06-10211-04	1000u, 16V, ±20%
C329, C330	06-22251-00	2200u/50V 20%
C323, C324	06-10351-04	10000u/50V 10%
RESISTORS		
R14, R24	07-10829-50	8.2Ω, 1/6W, ±5%
R129, R229	07-10100-50	10Ω, 1/6W, ±5%
R164, R264	07-10270-51	27Ω, 1/4W, ±5%
R128, R228	07-10330-50	33Ω, 1/6W, ±5%
R173, R181, R273, R281	07-10510-51	51Ω, 1/4W, ±5%
R160, R260	07-10820-50	82Ω, 1/6W, ±5%
R143, R149, R154, R243, R249, R254, R343	07-10101-50	100Ω, 1/6W, ±5%
R120, R140, R220, R240	07-10221-50	220Ω, 1/6W, ±5%
R153, R253	07-10241-50	240Ω, 1/6W, ±5%
R166, R266	07-10361-50	360Ω, 1/6W, ±5%
R165, R189, R265, R289	07-10391-50	390Ω, 1/6W, ±5%
R101, R103, R105, R107, R109, R111, R113, R115, R146, R201, R203, R205, R207, R209, R211, R213, R215, R246, R511, R512	07-10471-50	470Ω, 1/6W, ±5%
R193, R194, R293, R294	07-10511-50	510Ω, 1/6W, ±5%
R309, R310, R311, R313	07-10681-50	680Ω, 1/6W, ±5%
R17, R27	07-10821-50	820Ω, 1/6W, ±5%
R122, R148, R178, R195, R222, R248, R278, R295, R302, R304, R305, R306	07-10102-50	1KΩ, 1/6W, ±5%
R147, R247	07-10152-50	1K5Ω, 1/6W, ±5%
R125, R156, R225, R256, R312, R517	07-10222-50	2K2Ω, 1/6W, ±5%
R196, R296	07-10332-50	3K3Ω, 1/6W, ±5%
R126, R127, R226, R227	07-10472-50	4K7Ω, 1/6W, ±5%
R331	07-10682-50	6K8Ω, 1/6W, ±5%

R150, R151, R184, R185, R250, R251, R284, R285, R301, R303, R501, R502, R503, R504, R505, R507, R508, R513, R514, R515, R516	07-10103-50	10K Ω , 1/6W, \pm 5%
R192, R292	07-10153-50	15K Ω , 1/6W, \pm 5%
R139, R239	07-10203-50	20K Ω , 1/6W, \pm 5%
R141, R142, R180, R241, R242, R280, R320	07-10223-50	22K Ω , 1/6W, \pm 5%
R329	07-10303-50	30K Ω , 1/6W, \pm 5%
R339	07-10333-50	33K Ω , 1/6W, \pm 5%
R179, R182, R279, R282	07-10563-50	56K Ω , 1/6W, \pm 5%
R15, R158, R186, R25, R258, R286	07-10104-50	100K Ω , 1/6W, \pm 5%
R16, R114, R118, R136, R26, R214, R218, R236	07-10224-50	220K Ω , 1/6W, \pm 5%
R121, R221	07-10334-50	330K Ω , 1/6W, \pm 5%
R119, R219	07-10394-50	390K Ω , 1/6W, \pm 5%
R102, R104, R106, R108, R110, R112, R116, R171, R172, R202, R204, R206, R208, R210, R212, R216, R271, R272	07-10105-50	1Meg Ω , 1/6W, \pm 5%
R191, R291	07-21008-50	1 Ω , 1/6W, \pm 1%
R155, R255	07-28209-50	82 Ω , 1/6W, \pm 1%
R133, R233	07-21800-51	180 Ω , 1/4W, \pm 1%
R138, R238	07-24120-50	412 Ω , 1/6W, \pm 1%
R134, R234	07-23900-51	390 Ω , 1/4W, \pm 1%
R124, R224	07-24700-50	470 Ω , 1/6W, \pm 1%
R123, R132, R223, R232	07-27500-50	750 Ω , 1/6W, \pm 1%
R137, R237	07-21501-50	1K5 Ω , 1/6W, \pm 1%
R131, R231	07-23001-50	3K Ω , 1/6W, \pm 1%
R307	07-22002-50	20K Ω , 1/6W, \pm 1%
R308	07-22202-50	22K Ω , 1/6W, \pm 1%
R11, R21	07-98208-01	8.2 Ω , \pm 1%
R12, R22	07-91003-01	100K Ω , \pm 1%
R13, R23	07-92203-01	220K Ω , \pm 1%
R157, R257	07-24301-20	4K3 Ω , 1/2W, \pm 1%
R176, R276	07-30339-01	3.3 Ω , 1W, \pm 5%
R188, R288	07-30101-04	100 Ω , 2W, \pm 5%
R183, R283	07-30221-03	220 Ω , 2W, \pm 5%
R321	07-30511-00	510 Ω , 1/2W, \pm 5%
R167, R267	07-30102-05	1K Ω , 1W, FP, \pm 5%
R168, R268	07-30102-06	1K Ω , 3W, FP, \pm 5%
R190, R290	07-30332-03	3K3 Ω , 1W, FP, \pm 5%
R163, R263, R342	07-30472-00	4K7 Ω , 1/2W, FP, \pm 5%
R162, R262	07-30472-01	4K7 Ω , 1W, FP, \pm 5%
R175, R275	07-50100-01	10 Ω , 1W, FS, \pm 5%
R314, R317	07-50330-00	33 Ω , 1/2W, \pm 5%, FS
R187, R287	07-50470-00	47 Ω , 1/2W, FS, \pm 5%
R315, R316, R318, R319	07-50681-10	680 Ω , 1/2W, FS, \pm 5%
R174, R177, R274, R277	07-40687-03	0.068 Ω , 3W, CE, \pm 5%
INDUCTORS		
L12, L22	08-01010-00	1 μ H
L11, L21, L51	08-01101-01	100 μ H, \pm 20%
CRYSTAL		
X501	04-11102-00	11.0592MHz
POTS		
VR101, VR201	09-02101-00	100 Ω
VR103, VR203	09-02202-01	2K Ω
VR102, VR202	09-02203-00	20K Ω
RT31, RT32	09-01103-01	RK163121A2CA 10KAX2
RT34	09-01203-03	RK163121A10D 20KMN
SWITCHES		
SW31	11-02202-02	SPUN190700

RELAYS		
RL301	12-03102-00	JQX-115F/024-2HS4AF
CONNECTERS		
CB54	13-22503-00	XHB2.5A-3A
CB31, CB32	13-22505-00	XHB2.5A-5A
CB34	13-22509-00	XHB2.5A-9A
CB53	13-21219-00	FPC1.25 19PIN
4RCA	17-01004-00	AV4-8.4-13
6RCA	17-01006-00	AV6-8.4-13
Binding Post(Red)	73-001003-0	HS4-C320-B009V1-P003
BDP CAP(Red)	73-001005-0	HS4-C320-B009V1-P007
Shaft	69-001001-0	HS4-C320-B009V1-M024
Binding Post	69-001002-0	HS4-C320-B009V1-M025
Binding Post(Black)	73-001004-0	HS4-C320-B009V1-P004
BDP Cap(Black)	73-001006-0	HS4-C320-B009V1-P008
Shaft	69-001001-0	HS4-C320-B009V1-M024
Binding Post	69-001002-0	HS4-C320-B009V1-M025
PIN	69-010003-0	HS4-T972-B009V1-M017
LINKS		
J1, J3, J11, J46, J47, J48, J55, J56, J58, J73, J86, J102, J112, J113, J117, J120, J131, J132, J133, J134, J137, J140, J145, J149, J150, J155, J156, J157, J159, J167, J172, J174, J177, J182	21-06000-00	L=5
J4, J6, J16, J17, J19, J35, J36, J43, J44, J49, J50, J60, J69, J70, J71, J72, J81, J89, J101, J106, J119, J121, J123, J128, J136, J138, J170, J176, J178, J179, J181	21-06000-00	L=7.5
J2, J8, J12, J15, J21, J22, J23, J32, J34, J42, J45, J54, J57, J75, J76, J80, J98, J108, J122, J124, J139, J141, J160, J166	21-06000-00	L=10
J9, J10, J18, J26, J27, J28, J29, J30, J33, J53, J62, J63, J64, J74, J77, J78, J79, J94, J103, J107, J116, J142, J152, J153, J158	21-06000-00	L=12.5
J67, J105, J109, J110, J114, J118, J126, J144, J165, J168	21-06000-00	L=15
J24, J25, J52, J65, J66, J87, J147	21-06000-00	L=18
J41, J51, J91, J96, J97	21-06000-00	L=20
J13, J90, J95, J169	21-06000-00	L=22.5
J31, J37, J38, J39, J40, J82, J83, J84, J99, J151, J161, J162, J163	21-06000-00	L=25
J173	21-10000-00	L=12.5
J14, J88, J93, J115	21-10000-00	L=15
J7	21-10000-00	L=18
J5	21-10000-00	L=22.5
J85, J125	21-10000-00	L=25
ASSY HEATSINK		
Hexagon Socket Head Screw	61-354516-0	HS4-C315BEE-B009V1-M011
CLAMPER	66-001009-0	HS4-C320-B009V1-M012
Heatsink	70-076001-0	HS4-315BEE-B009V2-M005
Posistor	07-70471-08	PTH9M04BF471TS2F333
Q115, Q215	31-01943-00	2SA1943

Q117, Q217	31-05200-00	2SC5200
Heat Conductive Pad	78-001004-0	Berquist Sil-Pad K06-122
Plastic Plug	75-076002-0	HS4-C315BEE-B009V1-P007
PCB-4: STANDBY BOARD		
CIRCUIT NO.	PART NO.	DESCRIPTION
DIODES		
D501	33-50525-00	Φ5 DUAL COLOR
SWITCHS		
S507	11-04101-00	IT-1102D-1160
CONNECTER		
CZ52	13-22504-00	XHB2.5A-4A
PCB-2: POWER BOARD		
CIRCUIT NO.	PART NO.	DESCRIPTION
DIODES		
D402, D403	33-30822-00	8A/200V
BULBS AND HOLDER		
DS401, DS402	▲ 34-31501-00	JC-12V-35W-G4
DS401, DS402	▲ 34-31502-00	K522C
CAPACITORS		
C404	▲ 25-22422-03	MKP62, 275V, 0.22uF 5%
C403	▲ 05-47242-00	4n7p, 400V, ±20%
C403	▲ 78-001001-0	811810-23
C401, C402	▲ 25-10322-00	10n/250V 10%
FUSES		
F41	▲ 20-12162-01	T1.6AL250V 618 Series For C
F41	▲ 20-12312-02	T3.15AL250V 618 Series For AH
F41	▲ 20-20000-00	HF-004
CONNECTERS		
CB47	▲ 32-24804-00	KST 187
CB46	▲ 32-26304-00	KST 250
CB45	13-23903-01	VH 3.96A-3A
CB42	13-23903-00	VH 3.96A-3A
CB44	13-23903-01	VH 3.96A-3A
CB44	or13-23903-11	VH 3.96A-3A
CB41	13-23907-00	VH 3.96A-7A
CB41	or13-23907-10	VH 3.96A-7A
CB43-----CB32	14-31505-00	
LINKS		
J41	21-06000-00	L=10
J43	21-06000-00	L=12.5
J44	21-06000-00	L=15
J42	21-06000-00	L=20
PCB-6: KEY BOARD		
CIRCUIT NO.	PARTS NO	DESCRIPTION
ICS		
IR RECEIVER	03-00038-40	HS0038B4
DIODES		
D502, D503, D504, D505, D506, D507, D508	33-50350-00	φ3 GREEN LED
CAPACITORS		
C508, C509	05-10151-01	100p, 50V, ±10%
C502, C510	24-10461-00	0.1uF, 63V, ±20%
RESISTORS		
R519	07-10151-50	150Ω, 1/6W, ±5%
R509, R510	07-10103-50	10KΩ, 1/6W, ±5%
SWITCHS		
S501, S502, S503, S504, S505, S506	11-04101-05	IT-1102A-1160
CONNECTERS		
PHONE5	17-02001-14	JY-3562-01-350G
CZ53	13-21219-00	FPC1.25 19PIN
	76-076006-0	Tin Plate T=0.5mm
CZ53-----CB53	14-31519-00	1.25-19P-250mm

TP501-----CLASSIS	14-32501-12	1007#, 24AWG,35mm
CZ54——CB54	14-31503-01	SCN 2.5A-3D,XHB 2.5A-3Y。 UL1691, 24AWG/26AWG, 500mm
CB52-----CZ52	14-31504-00	XHB 2.54A-4Y, LD2.5A-4DW (JC) , 26AWG UL2468# , 62mm
PCB-3: POT BOARD		
CIRCUIT NO.	PART NO.	DESCRIPTION
POT		
RT33	09-01203-01	RK16812MG 20KBx2
CONNECTER		
CZ34	13-22509-00	XHB2.5A-9A
LINKS		
J31	21-06000-00	L=10
PCB-5: HEADPHONE BOARD		
CIRCUIT NO.	PART NO.	DESCRIPTION
CONNECTER		
CZ31	14-31505-01	LD2.5A-5DW (JC, XHB 2.5A- 5Y,26AWG UL2468# ,380mm
JK31	17-02001-00	6.35 PHONE JACK
OTHERS		
CIRCUIT NO.	PART NO.	DESCRIPTION
TRANSFORMER		
Transformer	 18-31512-21	TD-230-0150R / ETO06504RO
Transformer	 18-31512-10	TD-120-0150R / ETO06503RO
METAL PARTS		
Chassis	66-076001-1	HS4-C315BEE_B009V1-M001 C
Rear Panel	67-076002-1	HS4-C315BEE_B009V1-M002 B
Rear Panel	80-076002-1	SECC-N4,T=1.0mm Black
Rear Panel	65-076002-1	SECC-N4,T=1.0mm
Rear Panel	67-076012-1	HS4-C315BEE_B009V1-M002 B
Rear Panel	80-076002-1	SECC-N4,T=1.0mm Black
Rear Panel	65-076002-1	SECC-N4,T=1.0mm
Top Cover	67-076001-0	HS4-C315BEE_B009V1-M003
Top Cover	67-076011-0	HS4-C315BEE_B009V1-M003
Service Cover	66-076004-1	HS4-C315BEE_B009V1-M006 B
Compression Spring	92-076001-0	HS4-C315BEE_B009V1-M007
Lamper Cover	69-076001-1	HS4-C315BEE_B009V1-M004 C
METAL DISC	66-001008-0	HS4-C320-B009V1-M020
Phone holder	66-076005-0	HS4-C315BEE_B009V1-M008
SECC	81-001002-0	SECC-N4 1219×454.8×1
PLASTIC PARTS		
Tone Button	74-001001-2	HS4-C320-B009V1-P017
Tone Button	74-020003-1	HS4-C320-B009V1-P017
Trio Buttons	74-076001-1	HS4-C315BEE_B009V1-P001 B
Trio Buttons	74-076011-1	HS4-C315BEE_B009V1-P001 B
Power Button	74-076002-1	HS4-C315BEE_B009V1-P004
Power Button	74-076012-1	HS4-C315BEE_B009V1-P004
Tone Knob	73-014001-2	HS4-C320BEE-B009V1-P002
Tone Knob	73-020001-1	HS4-C320BEE-B009V1-P002
Volume Knob	73-014002-2	HS4-C320BEE-B009V1-P003
Volume Knob	73-020002-1	HS4-C320BEE-B009V1-P003
Fascia	77-076001-0	HS4-C315BEE_B009V1-P002
Fascia	77-076011-0	HS4-C315BEE_B009V1-P002
IR Lens	76-076001-0	HS4-C315Bee_B009V1-P005
LED Lens	76-003001-0	HS4-C160-B009V1-P005
FOOT ASSY	87-076001-0	
FOOT	75-076001-1	HS4-C315BEE_B009V1-P003 B
FOOT Pad	78-076001-0	HS4-C315BEE_B009V1-P006
Rubber Pad	78-076002-0	HS4-C315BEE_B009V1-P021
REMOTE CONTROL	J30-13150-01	AMP 1 Remote

BATTERIES	30-28601-00	CR2025
FASTENERS		
Self Taping Screw	61-023106-0	STB3×6
Self Taping Screw	61-084108-0	STPW4×8
Self Taping Screw	61-023208-0	BTB3×8
Self Taping Screw	61-023206-0	BTB3×6
Self Taping Screw	61-023204-0	BTB3×4
Self Taping Screw	61-063108-0	STF3×8
Self Taping Screw	61-022208-6	BTB2.6×8
Self Taping Screw	61-022206-6	BTB2.6×6
Self Taping Screw	61-022204-6	BTB2.6×4
Self Taping Screw	61-023506-0	MB3×6
Bolt	64-108050-0	M8×50
Nut	62-010802-0	M8
Spring Washer	63-020820-1	8mm
Pan washer	63-010816-0	8mm
ACCESSORIES		
Relief Bushing	84-001002-0	SB4F-4
Cable Tie	85-070001-0	4N-4
Cable Tie	84-001003-0	YJ-100
Cable Tie	84-001001-1	KL-2 (3M)
Heat Shrinking Tube	78-000220-0	φ22×25mm
2mm Rubber Pad	86-001004-0	Φ10×2mm
3mm Rubber Pad	86-009003-0	10×10×3mm
4mm Rubber Pad	86-010003-0	10×15×4mm
LED Lens Gum	86-046001-0	3M Double Side Adhesive
Nonwavens B	86-018001-0	24x14x0.5mm
Adhesive Bonded Fabric	86-014001-0	15x5×0.3mm
Rubber Washer	86-019002-0	110x25×1.3mm
PACKING		
POLYBAG	90-027001-0	350×600 T=1.0
Non-woven Cloth	90-009002-1	H=80 W=100 L=435
VERSION LABEL (C)	94-076001-0	85×115
VERSION LABEL (AH)	94-076002-0	85×115
VERSION LABEL (CT)	94-076003-0	85×115
VERSION LABEL (AHT)	94-076004-0	85×115
VERSION LABEL (BC)	94-076006-0	85×115
VERSION LABEL (CTBC)	94-076007-0	85×115
SERIAL NO LABEL	94-076005-0	60×10
CCC LABEL	94-014006-0	15mm×11.8mm
Guarantee Card	94-009005-0	AH
SAFETY LABEL	94-076008-0	25mm×20mm,80°C
CONNECTORS		
Connector	14-31502-02	VH 3.96A-3Y, Lonsid 187, 18AWG UL1672#, 80mm
Connector	14-31509-00	XHB 2.54A-9Y. 26AWG UL2468# 110mm
AC CORD (C)	△ 15-02250-00	LP21 & 2T / TQ-C36-P024, 2×0.75 Black L=1.83M AMP Terminal(2-520193-2)
AC CORD (AH)	△ 15-10120-02	LP5W & 2T / TQ-C36-P023, 18AWG 60°C Black L=2.0M AMP Terminal(2-520193-2)
ROCKER SWITCH	△ 11-01101-03	RF-1003-BB2, 10A 250V, TV-5
NOTES:		
	AH	C
TRANSFORMER	TD-120-0150R / ETO06503RO	TD-230-0150R / ETO06504RO
AC CORE	LP5W & 2T / TQ-C36-P023, 18AWG 60°C Black L=2.0M AMP Terminal(2-520193-2)	LP21 & 2T / TQ-C36-P024, 2×0.75 Black L=1.83M AMP Terminal(2-520193-2)

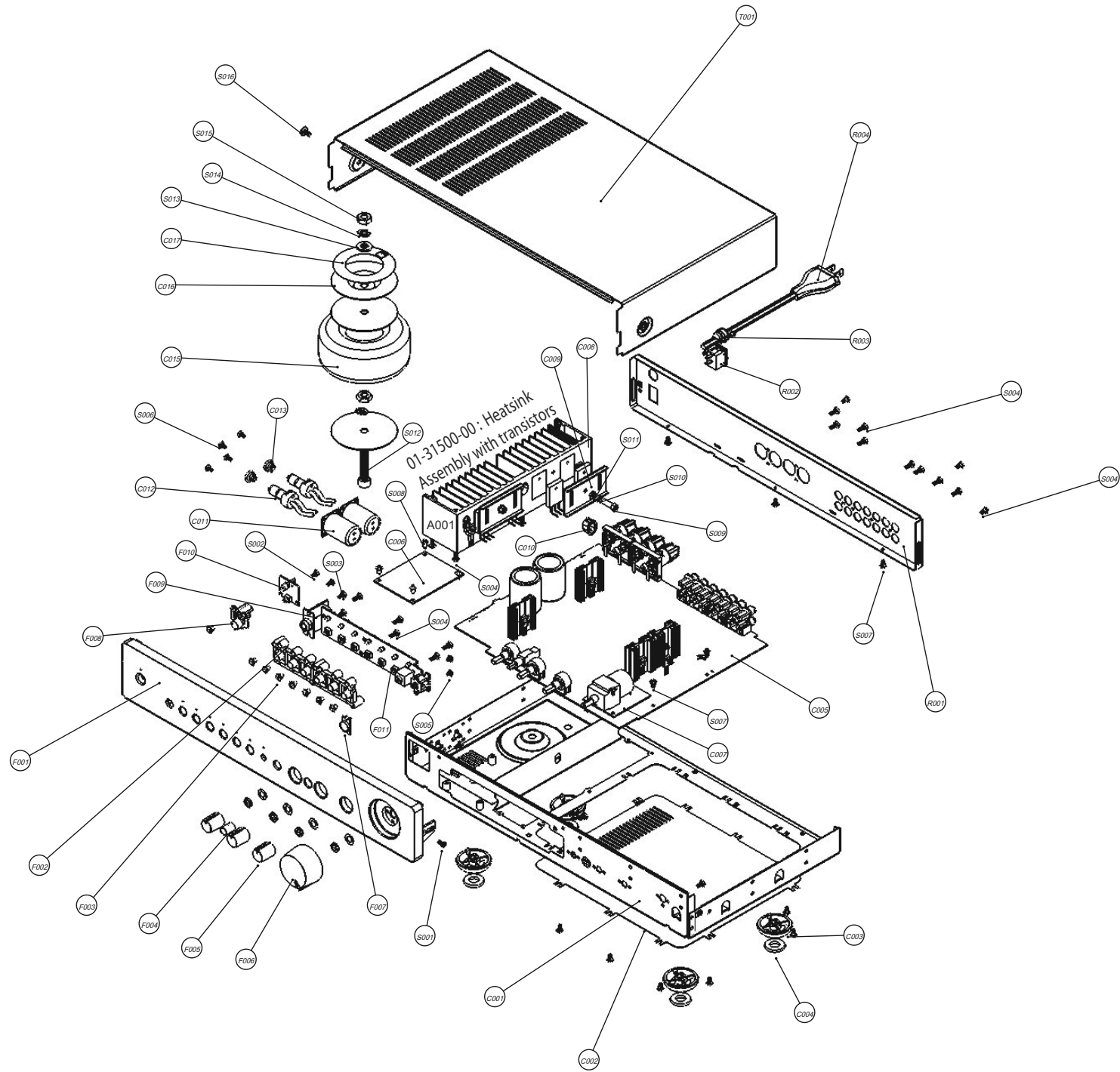

EXPLODED VIEW PARTS LIST

REF.NO	PART NO.	DESCRIPTION	Qty.	REF.NO	PART NO.	DESCRIPTION	Qty.
C001	66-076001-1	Chassis	1	R001	80-076002-1	Rear Panel	1
C002	66-076004-1	Service Cover	1	R002	11-01101-03	ROCKER SWITCH	1
C003	75-076001-1	Foot Pad	4	R003	85-070001-0	Cable Tie	1
C004	78-076001-0	Foot Pad	4	R004	15-02250-00	AC CORD (C)	1
C005*	01-31501-10	Main Board(AH) green LED	1		15-10120-02	AC CORD (AH)	1
	01-31501-20	Main Board(C) green LED	1				
C006	01-31502-10	PSU Board(AH)	1	T001	67-076001-0	Top Cover	1
	01-31502-20	PSU Board(C)	1				
C007	01-31504-00	Pot PCB	1				
C008	70-076001-0	Heatsink	1				
C009	66-001009-0	Clamper	2	S001	61-063108-0	STF3×8 Screw	2
C010	75-076002-0	Plastic Plug	1	S002	61-022208-6	BTB2.6X8 Screw	2
C011	69-076001-1	Lamper Cover	2	S003	61-023206-0	BTB3X6 Screw	2
C012	34-31501-00	Light Bulb	2	S004	61-063108-0	BTB3×8 Screw	24
C013	92-076001-0	Compression Spring	2	S005	61-022204-6	BTB2.6×4 Screw	2
C014	66-076009-0	Sheild Plate	1	S006	61-022206-6	BTB2.6×6 Screw	4
C015	18-31512-10	Transformer AH	1	S007	61-023106-0	STB3x6 Screw	20
	18-31512-21	Transformer C	1	S008	61-023506-0	MB3x6 Screw	4
C016	66-001008-0	Metal DISC	1	S009	61-354516-0	M4X16 Hexagon Socket Head Screw	2
C017	94-001004-2	LABEL	1	S010	63-020411-0	Spring Washer φ 4	2
				S011	63-010408-0	Plain Washer φ 4	2
				S012	64-108050-0	M8X50 Bolt	1
				S013	63-010816-0	Plain washer φ 8	1
F001	77-076001-0	Fascia	1	S014	63-020820-0	Φ 8Spring Washer	2
F002	74-076001-1	Trio Buttons	2	S015	62-010802-0	M8 Nut	2
F003	76-003001-0	LED Lens	8	S016	61-084108-0	STPW4×8 Screw	2
F004	74-001001-2	Tone Button	1	A001	01-31500-00	Heatsink with trasnsitors	1
F005	73-014001-2	Tone Knob	3				
F006	73-014002-2	Volume Knob	1				
F007	76-076001-0	IR Lens	1				
F008	74-076002-1	Power Button	1				
F009	01-31506-00	C315BEE Phone PCB	1				
F010*	01-31505-00	STANDBY PCB green LED	1				
F011*	01-31503-00	Key Board green LED	1				

***Note:** F010 and F011 sold together part #01-31599-00 with green LEDs or part #01-31599-01 with blue LEDs

PACKING DIAGRAM

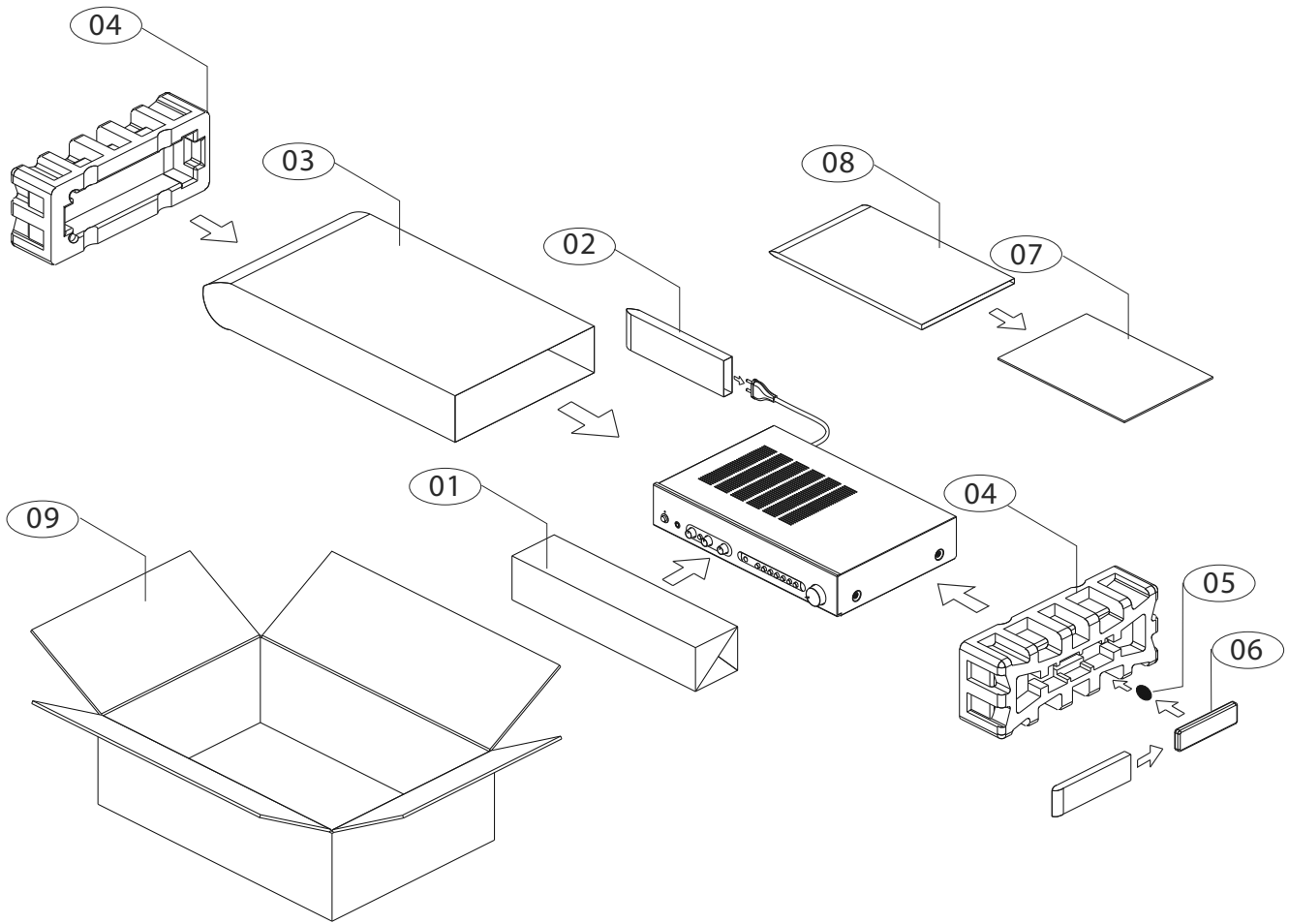

Ref. No.	Part No.	Description	Q'TY
01	90-009002-1	Non Woven Cloth	1
02	90-001013-0	AC Cord Polybag	1
03	90-027001-0	Polybag	1
04	89-076001-1	Polyfoam End Cap	2
05	30-28601-00	Battery CR2025	1
06	J30-13150-01	Remote Control Amp1	1
07	30-43150-00	IM 1(E nglis h)	1
	30-43151-00	IM 2(B, C)	1
08	90-001002-	Manual Polybag	1
09	88-076001-0	Carton Box	1

Proprietary information for servicing purposes only.
 The information herein may not be used commercially without the prior written agreement of NAD International, Toronto, Canada.

