

SERVICE MANUAL



C 326BEE
Stereo Integrated Amplifier

C 326BEE
Stereo Integrated Amplifier

SAFETY INFORMATION

<p>NAD® Soft Clipping™ and Power Drive™ are trademarks of NAD Electronics International, a division of Lenbrook Industries Limited. © NAD All Rights Reserved</p>
<p>NAD ELECTRONICS INTERNATIONAL 633 GRANITE COURT, PICKERING, ON, CANADA L1W 3K1 MODEL C 326BEE STEREO INTEGRATED AMPLIFIER POWER RATING 120V ~ 60Hz 1.5A DESIGNED & ENGINEERED IN CANADA, CUSTOM MANUFACTURED TO NAD SPECIFICATIONS IN CHINA</p>
<p>NAD ELECTRONICS INTERNATIONAL MODEL C 326BEE STEREO INTEGRATED AMPLIFIER POWER RATING 230V ~ 50Hz 1A DESIGNED & ENGINEERED IN CANADA, CUSTOM MANUFACTURED TO NAD SPECIFICATIONS IN CHINA</p>
<p>CAUTION RISK OF ELECTRIC SHOCK DO NOT OPEN WARNING: SHOCK HAZARD - DO NOT OPEN AVIS: RISQUE DE CHOC ELECTRIQUE - NE PAS OUVRIR</p>

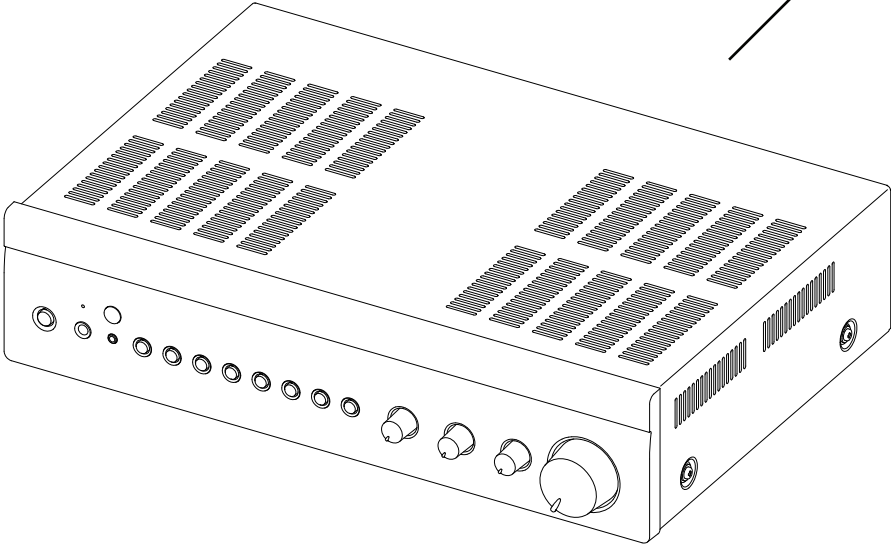
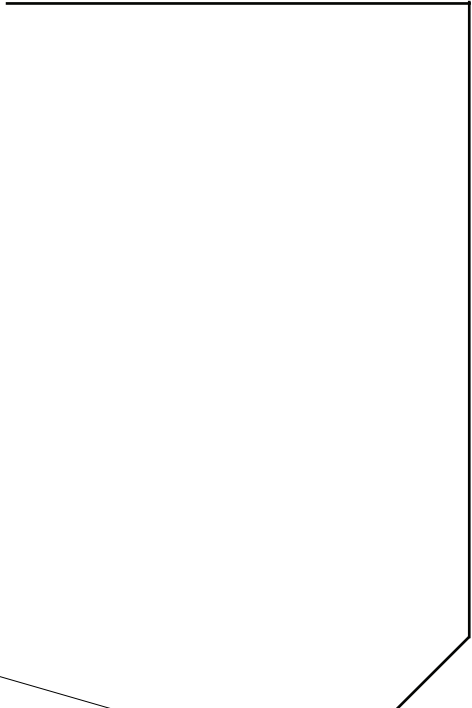

SERVICE SAFETY PRECAUTIONS

1. Replacing the fuses

CAUTION:

FOR CONTINUED PROTECTION AGAINST THE RISK OF FIRE REPLACE ONLY WITH SAME TYPE OF FUSE.

Reference Designator		Database Part Number	Description
F601*AH	⚠	20-001-0086-90	FUSE 3.15A 250V TIME LAG LBC 5x20mm TSD UL/CSA/VDE/SEMKO
F601*C,CT	⚠	20-001-0076-90	FUSE 1.6A 250V TIME LAG LBC 5X20mm TSD UL/CSA/VDE/SEMKO (RoHS)

NOTE:

- <*AH > : USA, CANADIAN MODEL ONLY.
- <*C, *CT > : EUROPEAN MODEL ONLY.

2. Safety check out

(Only U.S.A. model)

Before returning the product to the customer, make leakage current or resistance measurements to determine that exposed parts are acceptably insulated from supply circuit.

Parts marked with the symbol ⚠ are critical with regard to the risk of fire and electric shock.

CONTENTS

DESCRIPTION	PAGE
SPECIFICATIONS.....	4 - 5
REAR PANEL / FRONT PANEL VIEW	6
DISASSEMBLY INSTRUCTIONS	7
WIRING DIAGRAM	8 - 9
BLOCK DIAGRAM.....	10
ADJUSTMENT POINTS DIAGRAM / AMPLIFIER ADJUSTMENT	11
PCB LAYOUT	12 - 15
SCHEMATIC DIAGRAM.....	16 - 19
ELECTRICAL PARTS LIST	20 - 31
IC BLOCK DIAGRAM.....	32 - 34
EXPLODED VIEW.....	35 - 36
EXPLODED VIEW PARTS LIST	37 - 38
PACKING DIAGRAM.....	39

SPECIFICATIONS

PRE AMPLIFIER SECTION

LINE LEVEL INPUT, PRE-OUT

THD (2 Vin 2 Vout, CCIF IMD, DIM 100)

Signal/Noise ratio IHF

> 0.004 % (ref. 20 Hz – 20 kHz)
>100 dB (A-weighted, ref. 500 mV)
>108 dB (A-weighted, ref. 2V, Volume max.)
>92 dB (A-weighted, ref. 100 mV in 100 mV out - unity gain)

Channel separation - 1 kHz
10 kHz

>80 dB
>70 dB

Input impedance (R and C)

100 k Ω + 320 pF

Maximum input signal

>8 Vrms (ref. 0.1 THD)

Output impedance - Pre out

75 Ω

Tape out

Source Z + 1 k Ω

Input sensitivity

159 mV (ref. 500 mV out)

Frequency response

\pm 0.1 dB (ref. 20 Hz - 20 kHz, Tone defeat ON)
 \pm 0.5 dB (ref. 20 Hz - 20 kHz, Tone defeat OFF)

Maximum voltage output - IHF load

>10 V (ref. 0.03% THD)

600 ohms load

>10 V (ref. 0.03% THD)

TONE CONTROLS

Treble

\pm 5 dB at 10 kHz

Bass

\pm 8 dB at 100 Hz

POWER AMPLIFIER SECTION

MAIN IN, SPEAKER OUT

Continuous output power into 8 Ω and 4 Ω (Stereo)

>50 W (ref. rated THD, 20 Hz-20 kHz, both channels driven)

Rated THD (CCIF IMD, DIM 100)

<0.009 % (ref. 20 Hz - 20 kHz)

Clipping power

>65 W (ref. 1 kHz 1% THD)

IHF dynamic power - 8 Ω

100 W

4 Ω

150 W

2 Ω

200 W

Peak output current

>20 A (ref. 1 Ω , 1 ms)

Signal/Noise ratio

>100 dB (A-weighted, ref. 1 W)
>117 dB (A-weighted, ref. 150 W)

Damping factor

>100 (ref. 8 Ω , 50 Hz and 1 kHz)

Frequency response

\pm 0.1 dB (ref. 20 Hz - 20 kHz)

Input impedance

3 Hz – 70 kHz (ref. -3 dB)

Input sensitivity

20 k Ω + 1 nF

Voltage gain

630 mV (ref. rated power)

Headphone output impedance

29 dB

Channel separation - 1 kHz

68 Ω

10 kHz

>80 dB

>70 dB

TRIGGER OUT

Output resistance

<100 Ω

Output current

50 mA

Output voltage

+12 V

OVERALL SPECIFICATIONS

CD IN, SPEAKER OUT

THD (250 mW to rated power, CCIF IMD, DIM 100)

<0.009 % (ref. 20 Hz - 20 kHz)

Signal/Noise ratio

>94 dB (A-weighted, ref. 1 W)

>110 dB (A-weighted, ref. 50 W, volume set for 2V)

Frequency response	± 0.2 dB (ref. 20 Hz - 20 kHz, Tone Defeat ON) 10 Hz – 65 kHz (ref. -3 dB)
Channel separation - 1 kHz	>80 dB
10 kHz	>70 dB

POWER CONSUMPTION

Rated power	290 W (ref. 230V AC 50 Hz; 120V AC 60 Hz)
Standby power	<1 W
Idle power	<35W

PHYSICAL SPECIFICATIONS

Dimensions (Width x Height x Depth)	435 x 100 x 286 mm (Net) 435 x 116 x 332 mm (Gross*)
	* - Gross dimensions include feet, volume knob and extended speaker terminals.
Net Weight	7.1 Kg (15.62 lbs)
Shipping Weight	9.1 Kg (20.02 lbs)

REAR PANEL / FRONT PANEL VIEW

REAR PANEL

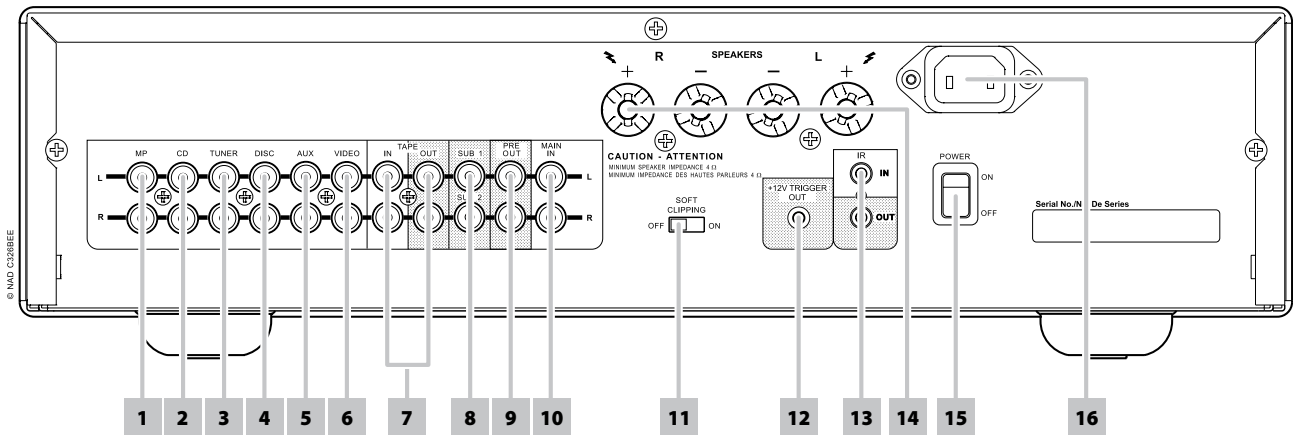

- | | | |
|----------------|----------------------|--------------------|
| 1. MP INPUT | 7. TAPE IN/OUT | 13. IR IN/OUT |
| 2. CD INPUT | 8. SUB 1, SUB 2 | 14. SPEAKERS |
| 3. TUNER INPUT | 9. PRE OUT | 15. POWER SWITCH |
| 4. DISC INPUT | 10. MAIN IN | 16. AC MAINS INPUT |
| 5. AUX INPUT | 11. SOFT CLIPPING | |
| 6. VIDEO INPUT | 12. +12V TRIGGER OUT | |

FRONT PANEL

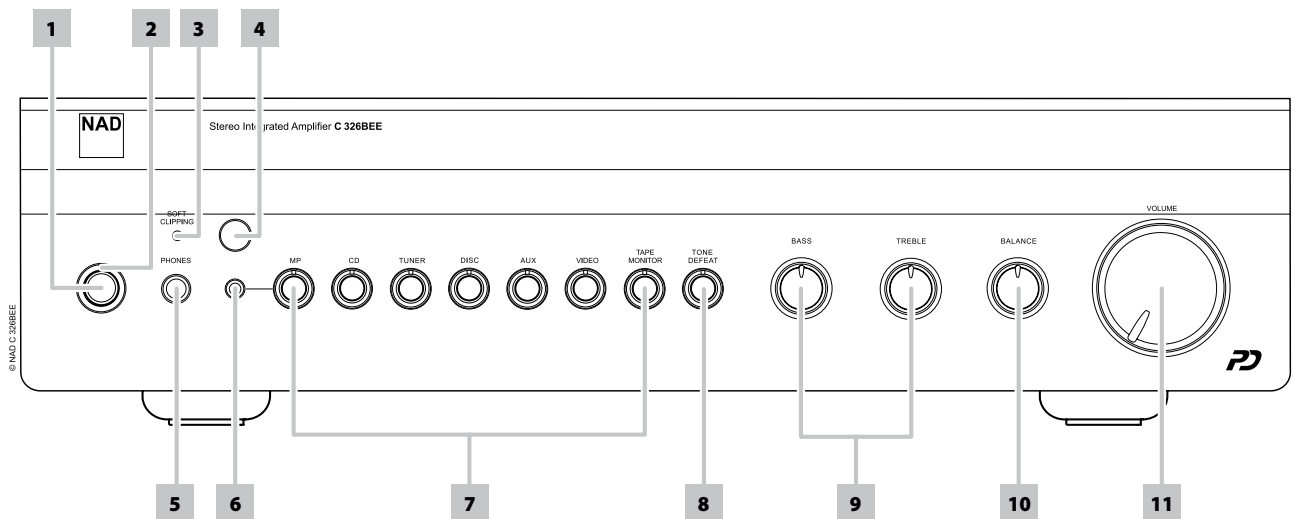

- | | |
|----------------------------|-------------------|
| 1. STANDBY | 6. MP SOCKET |
| 2. STANDBY LED | 7. INPUT SELECTOR |
| 3. SOFT CLIPPING INDICATOR | 8. TONE DEFEAT |
| 4. REMOTE SENSOR | 9. TONE CONTROLS |
| 5. PHONES | 10. BALANCE |
| | 11. VOLUME |

DISASSEMBLY INSTRUCTIONS

1. Remove machine screws M4.0 x 8.0 (**x 4pcs**) from the side panels.
Remove tapping screw 3.0 x 8.0 (**x 3pcs**) from the back panel.
Refer to **Figure No. 1**.

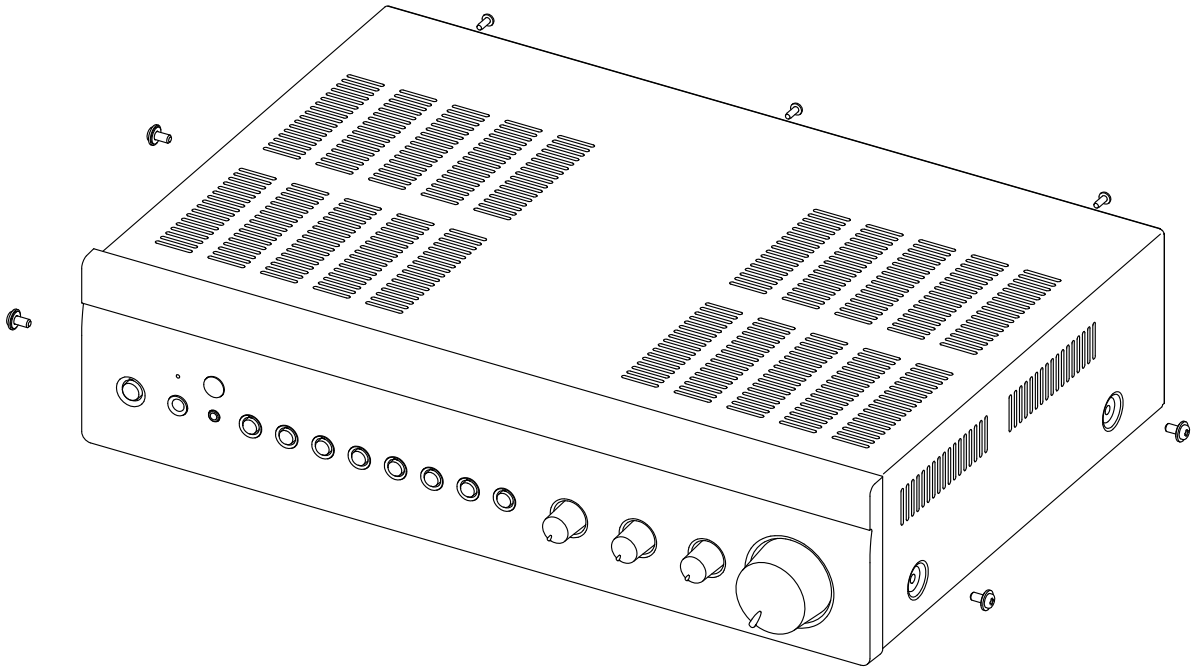

Figure No. 1

2. Pull both sides of the TOP COVER slightly outwards and tilt approx. 35 ° and then remove in the direction as indicated. Refer to **Figure No. 2**.

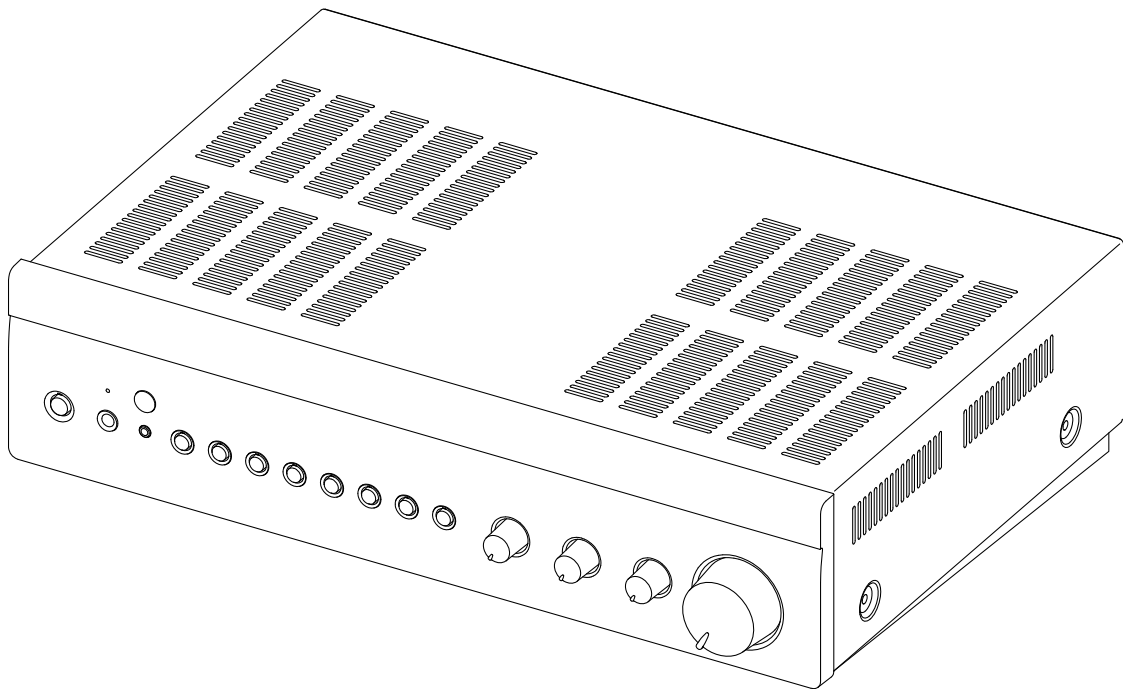
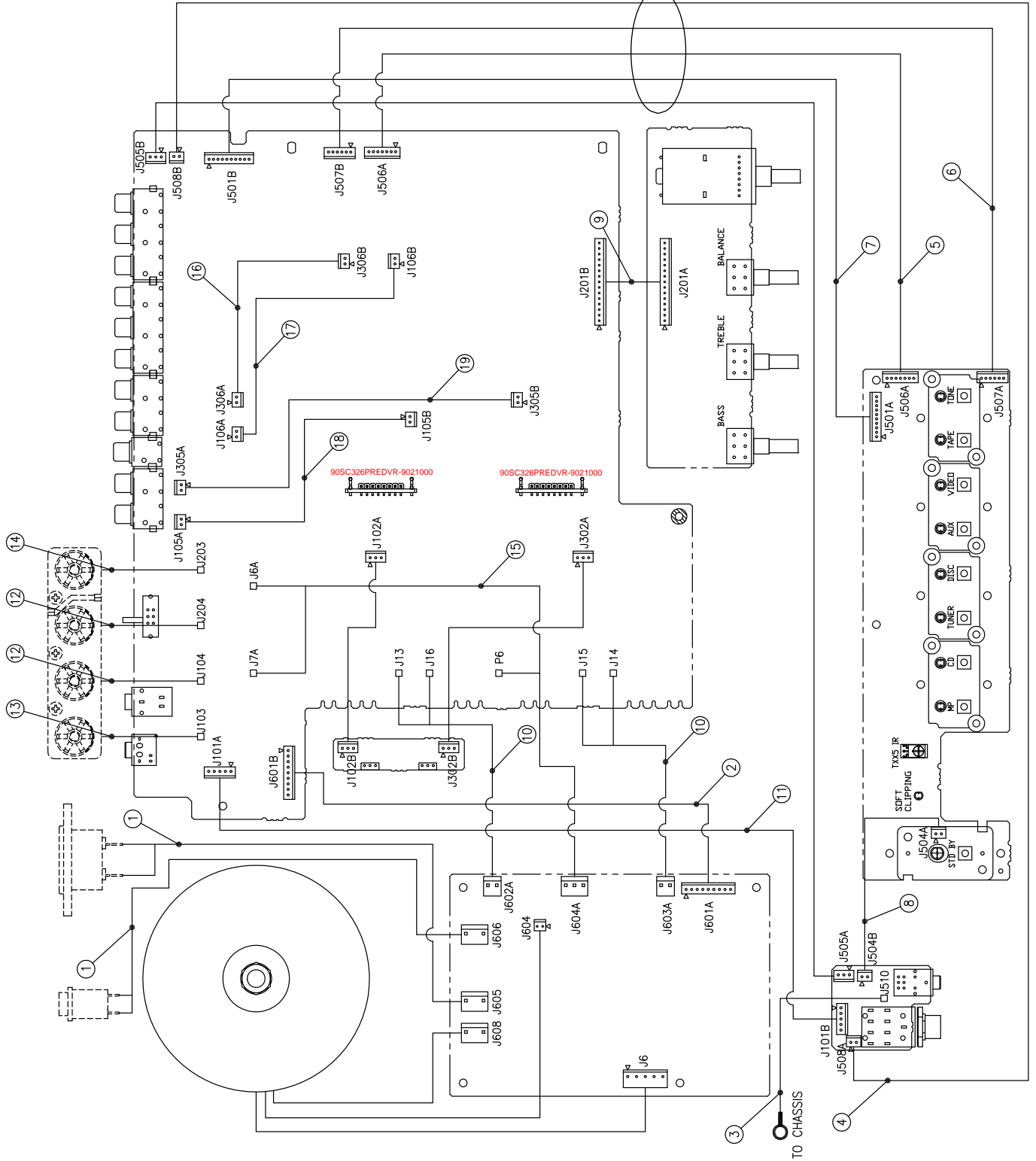

Figure No. 2

WIRING DIAGRAM

Check these cables for damage caused by chassis lip.



WIRING DIAGRAM PARTS LIST

Item	Database Part Number	Description	Remark
1	17-012-4444-90	CABLE ASSY 3 WAYS AWG18 3.96P PIN 2 VOID UL1672 L=170mm (B/BR) (RoHS)	PSU BD-J605, J606
2	17-012-4422-90	CABLE ASSY 9 WAYS AWG=26 2.5P UL1007 L=240mm (RoHS)	PSU BD-J601A
3	17-012-2956-90	Cable assy 1 way AWG18 UL1007 BLACK L=100mm W/RING TERMINAL (RoHS)	PHONE BD-J510
4	17-012-4536-90	CABLE ASSY 2 WAYS AWG26 2.5P UL2468 L=700 (RoHS)	PHONE BD- J508A
5	17-012-4424-90	CABLE ASSY 7 WAYS AWG=28 2.0P UL1007 L=350mm (RoHS)	KEY BD-J506A
6	17-012-4425-90	CABLE ASSY 6 WAYS AWG=28 2.0P UL1007 L=410mm (RoHS)	KEY BD-J507A
7	17-012-4426-90	CABLE ASSY 10 WAYS AWG=28 2.0P UL1007 L=420mm (RoHS)	KEY BD-J501A
8	17-012-4427-90	CABLE ASSY 2 WAYS AWG=26 2.5P UL1007 L=80mm (RoHS)	KEY BD-J504A
9	17-012-4423-90	CABLE ASSY 15 WAYS AWG=26 2.5P UL1007/1533 L=80mm (RoHS)	VOL BD-J201A
10	17-012-4420-90	CABLE ASSY 2 WAYS AWG=16 3.96P WHI/RED UL1015 L=100mm (RoHS)	MAIN BD-J13/ J16, J14/J15
11	17-012-4428-90	CABLE ASSY 5 WAY AWG26 2.5P UL1007 L=250mm (RoHS)	MAIN BD-J101A
12	17-012-4483-90	CABLE ASSY 1 WAY AWG14 UL1015 L=80mm BLACK W/ RING TERMINAL (RoHS)	MAIN BD-J104, J204
13	17-012-4484-90	CABLE ASSY 1 WAY AWG14 UL1015 L=110mm WHITE W/ RING TERMINAL (RoHS)	MAIN BD-J103
14	17-012-4485-90	CABLE ASSY 1 WAY AWG14 UL1015 L=110mm RED W/ RING TERMINAL (RoHS)	MAIN BD-J203
15	17-012-4521-90	CABLE ASSY 3 WAYS AWG16 3.96P BLACK UL1015 L=200/120/220mm (RoHS)	MAIN BD-J7A/ P6/J6A
16	17-012-4529-90	CABLE ASSY 2 WAYS AWG26x1C 2.5P UL1533 L=90 (RoHS)	MAIN BD- J306A/B
17	17-012-4530-90	CABLE ASSY 2 WAYS AWG26x1C 2.5P UL1533 L=110 (RoHS)	MAIN BD- J106A/B
18	17-012-4531-90	CABLE ASSY 2 WAYS AWG26x1C 2.5P UL1533 L=130 (RoHS)	MAIN BD- J105A/B
19	17-012-4532-90	CABLE ASSY 2 WAYS AWG26x1C 2.5P UL1533 L=180 (RoHS)	MAIN BD- J305A/B

BLOCK DIAGRAM

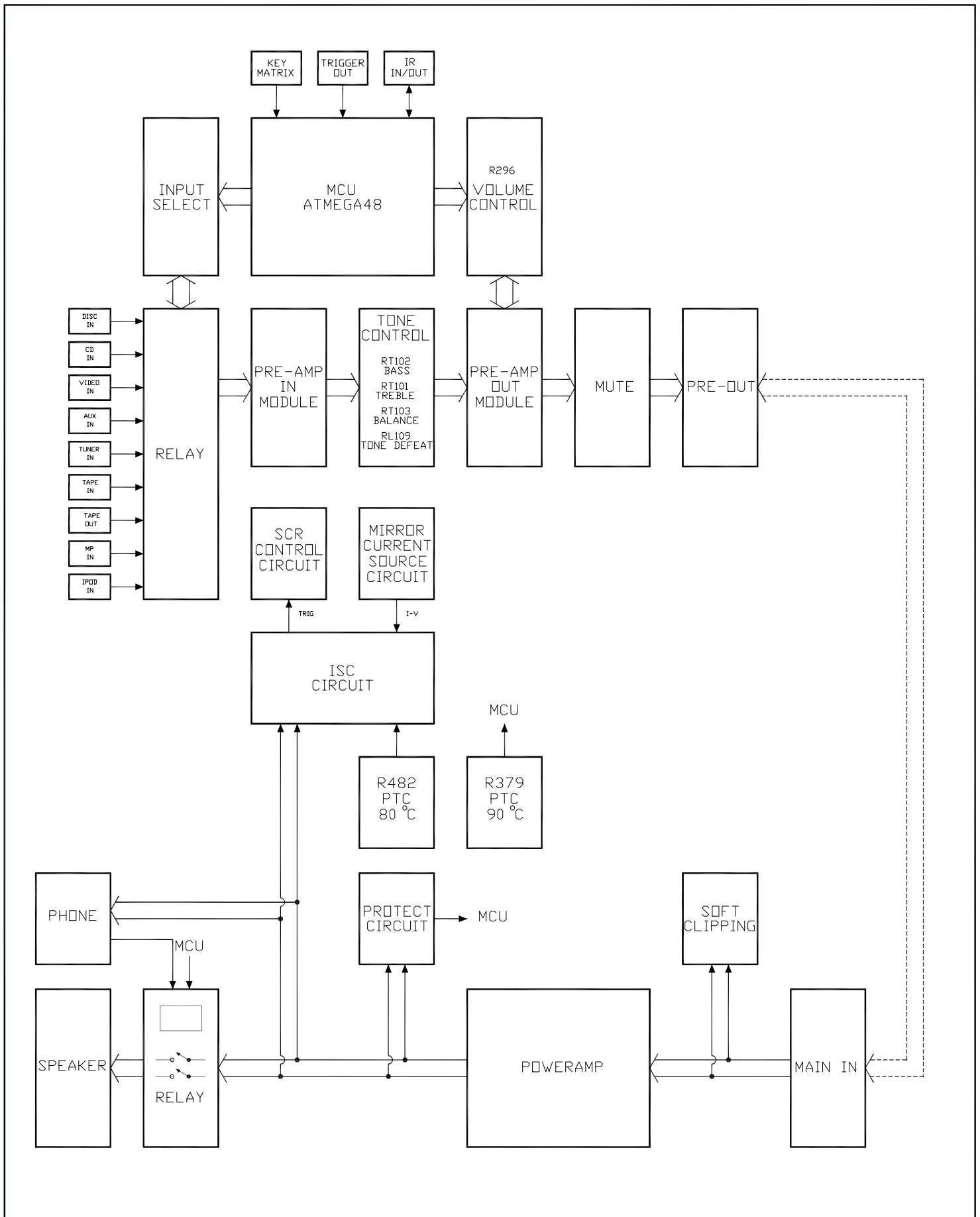

ADJUSTMENT POINT DIAGRAM

A. Idle Current adjustment

1. Turn on the unit without any input for 15 minutes
2. For left channel, adjust VR103
Voltage across TP1 & TP2 3 – 3.5mV
3. For right channel, adjust VR303
Voltage across TP3 & TP4 3 – 3.5mV
4. With the unit keep turning on, wait for another 15 minutes
5. Re-adjust VR103
Voltage across TP1 & TP2 3 – 3.5mV
6. Re-adjust VR303
Voltage across TP3 & TP4 3 – 3.5mV

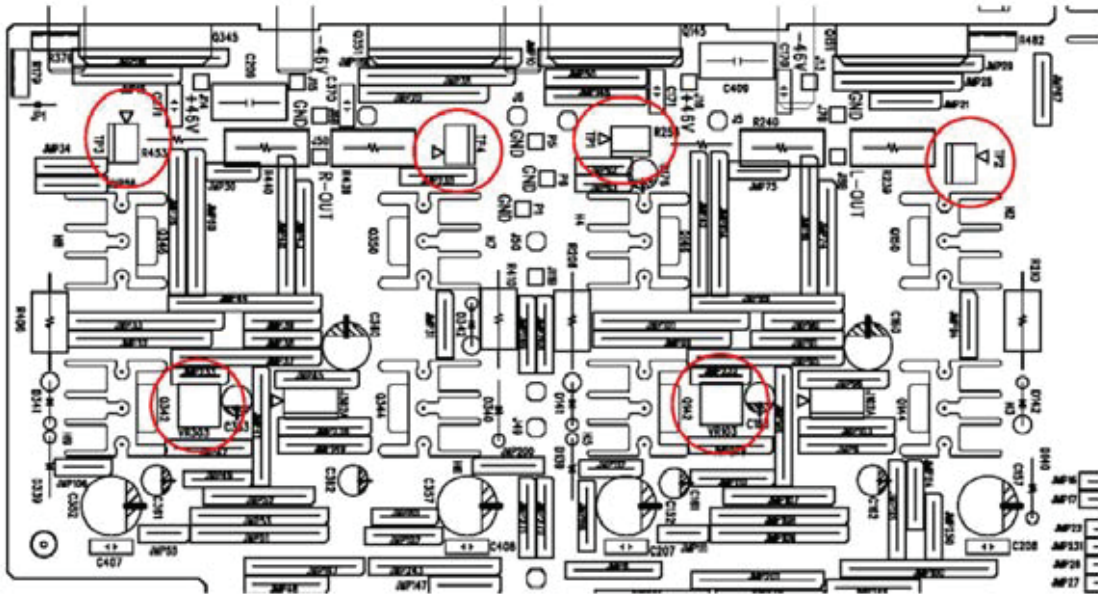

B. ISC adjustment

1. Turn VR304 fully anti-clockwise,
2. Use 500mV, 1kHz sine wave, CD input, 4 ohm loading to both channels
3. Increase the output power of both channels to 8V
4. Slowly rotate VR304 clockwise until the voltage at TP10 is the same as TP11
5. Verify the output at 20kHz 8 ohm loading to both channels are larger than 21V, if not, repeat step 1-4 again

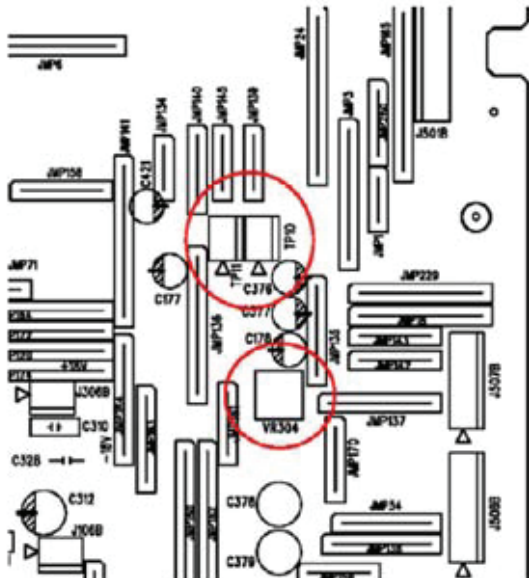

PCB LAYOUT

MAIN BOARD - COPPER SIDE

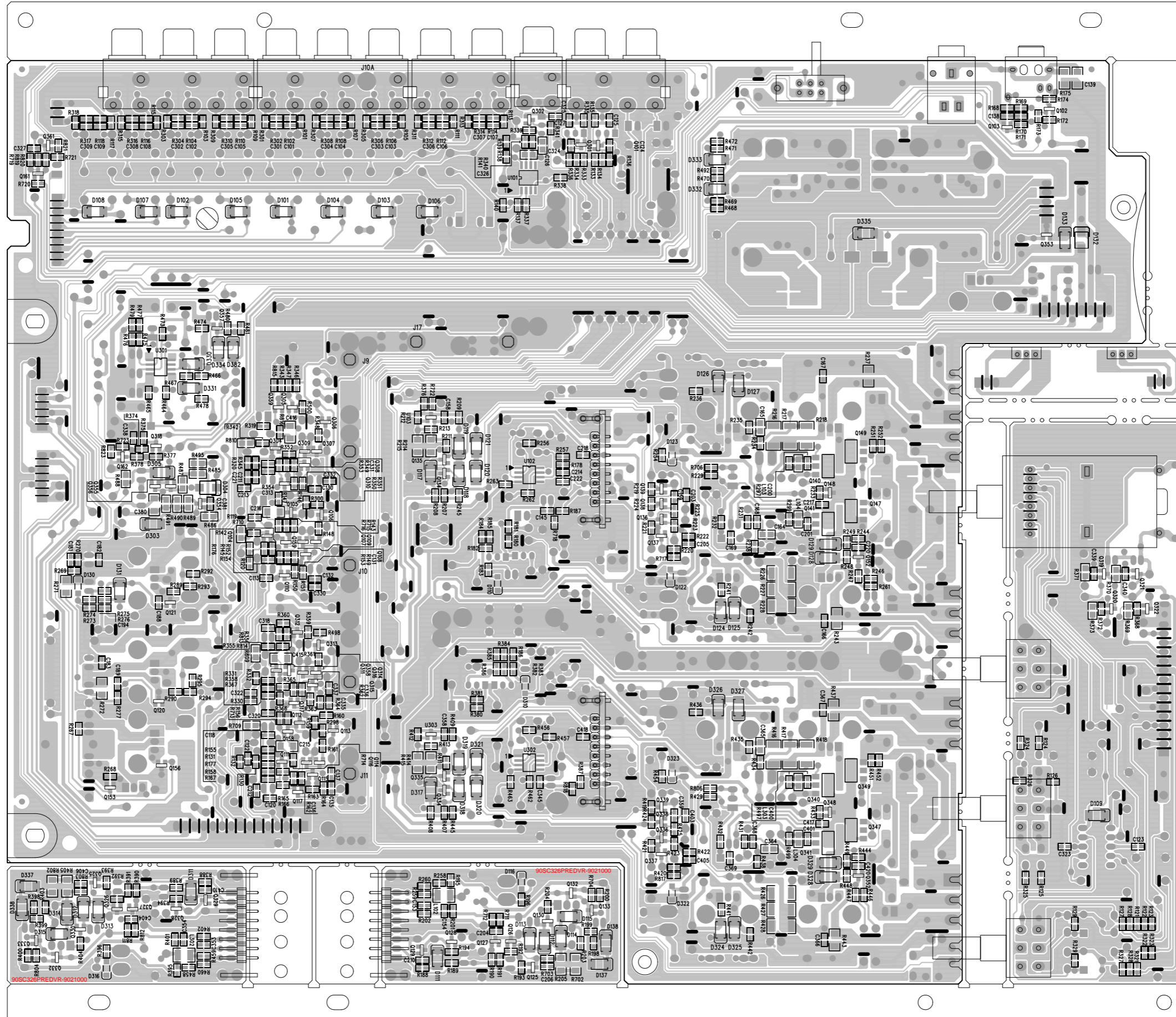

MAIN BOARD - COMPONENT SIDE

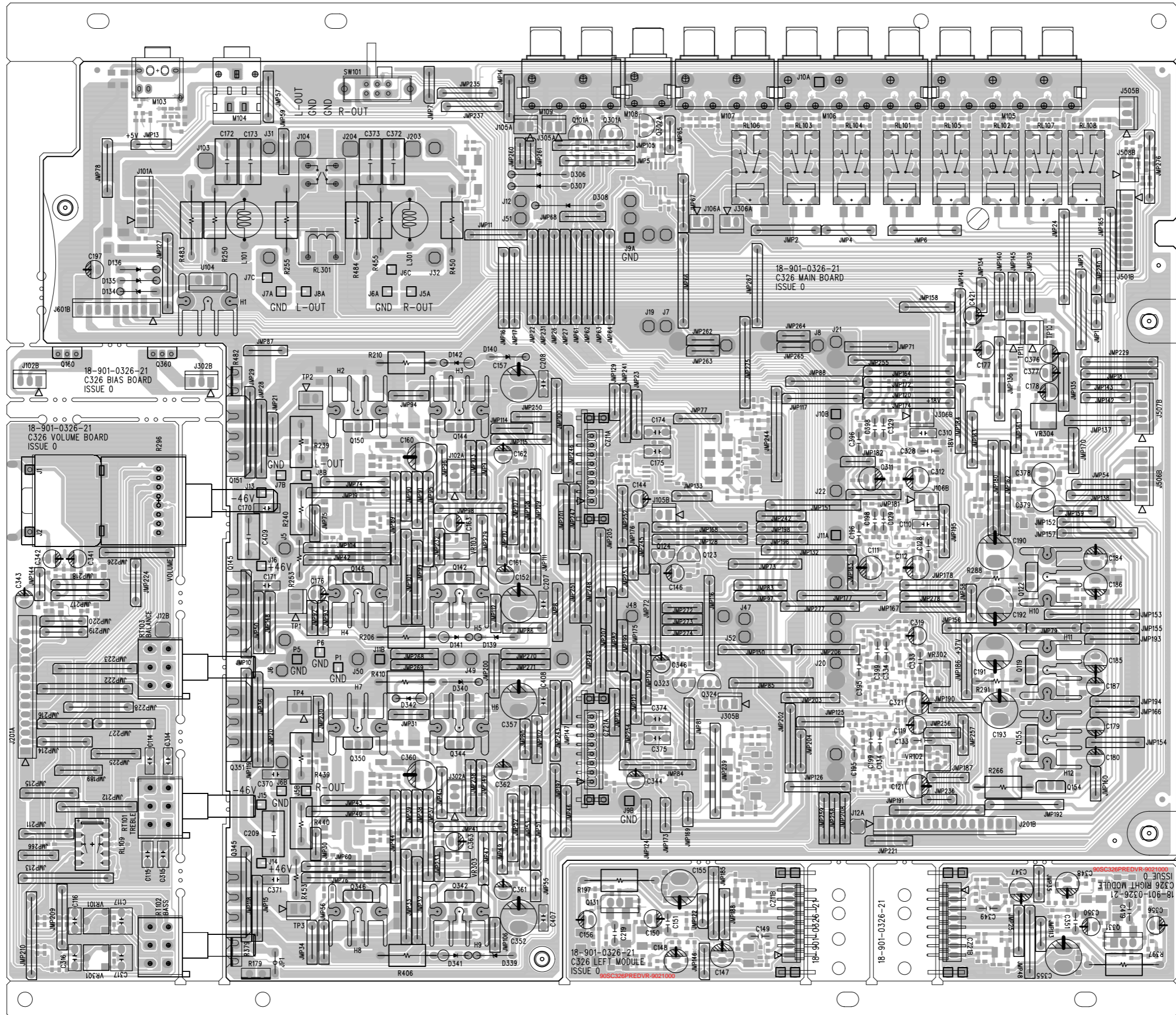

KEY BOARD & PHONE BOARD - COMPONENT SIDE

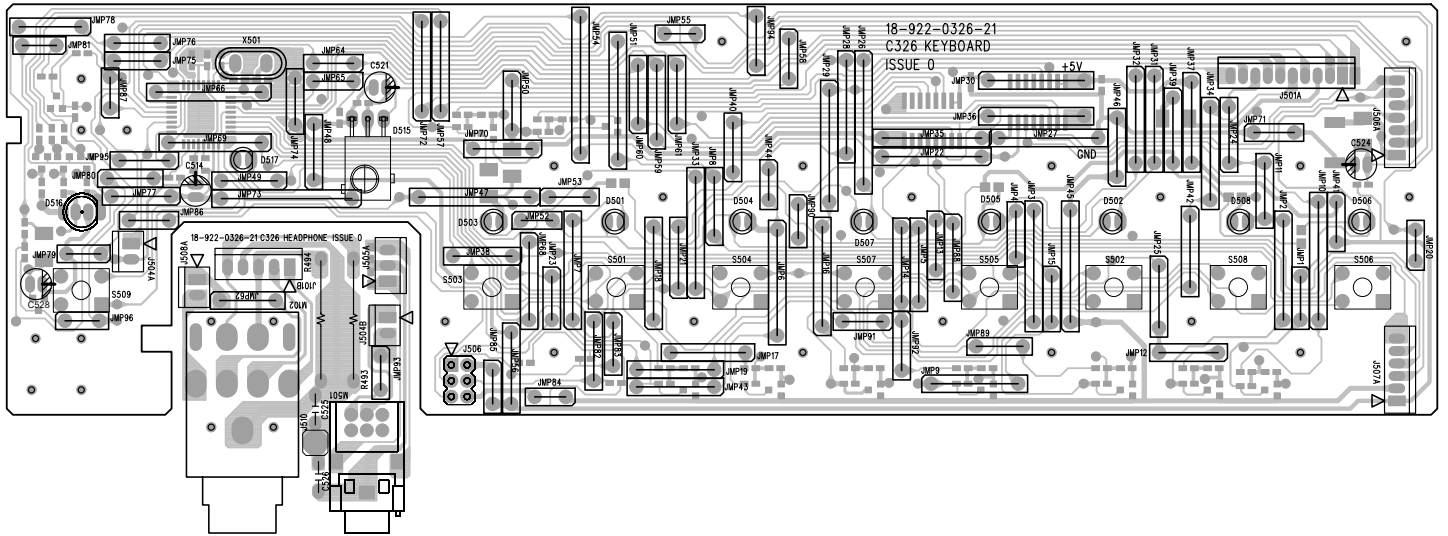

KEY BOARD & PHONE BOARD - COPPER SIDE

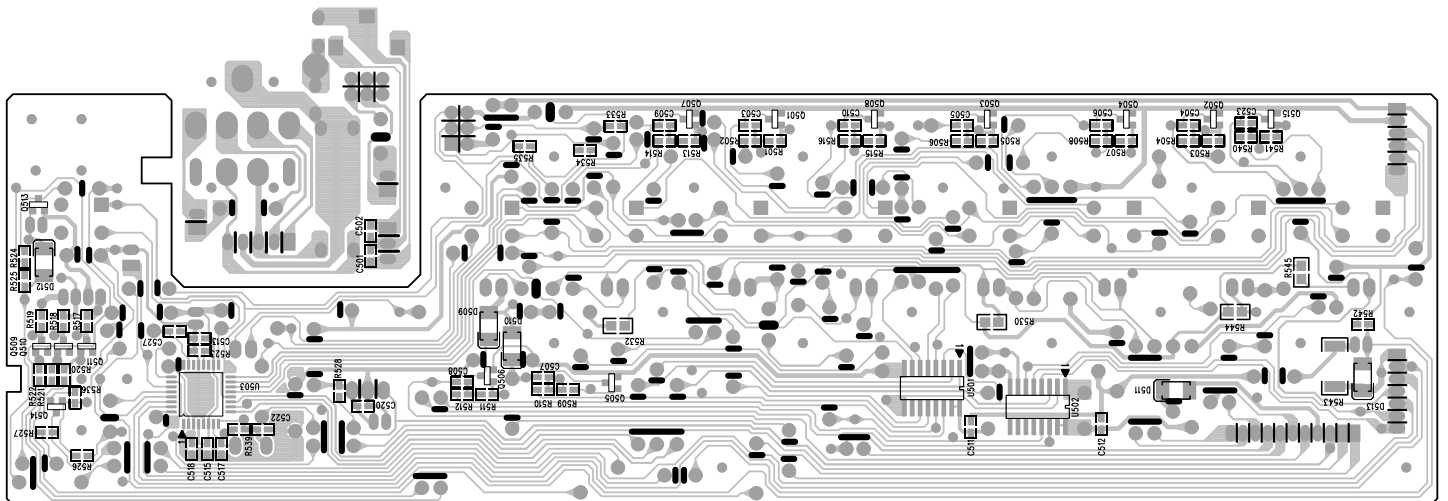

PSU BOARD - COMPONENT SIDE

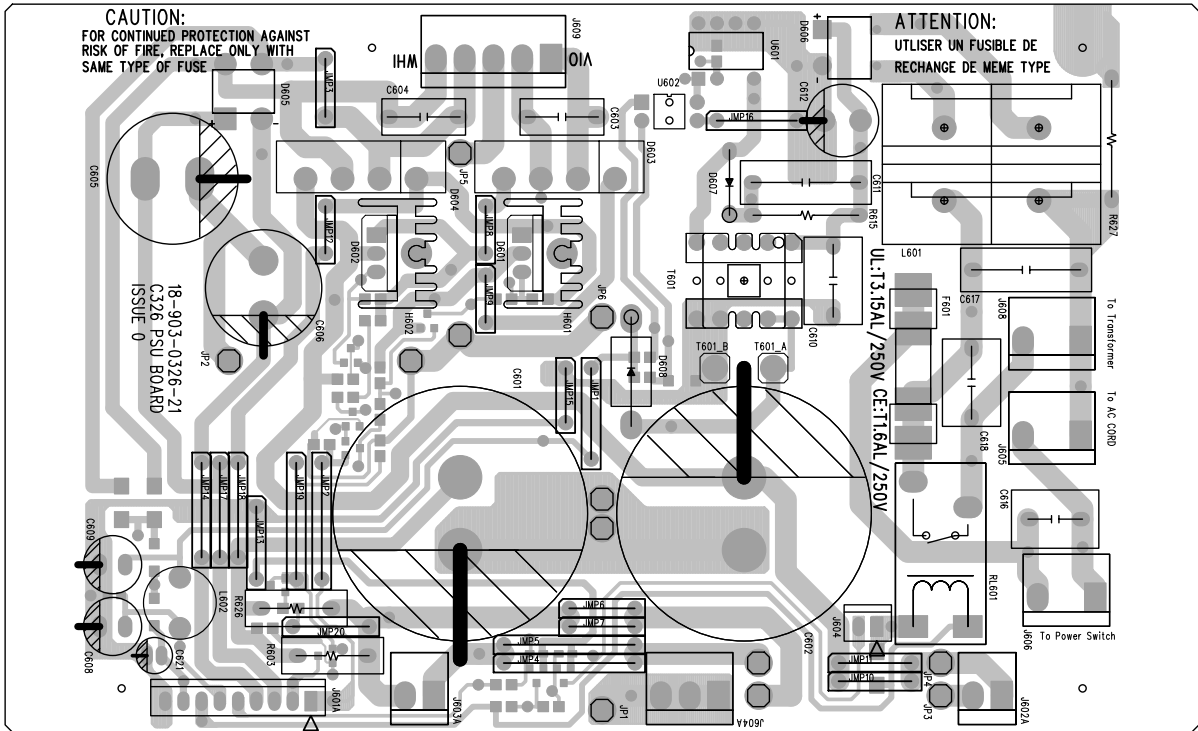

PSU BOARD - COPPER SIDE

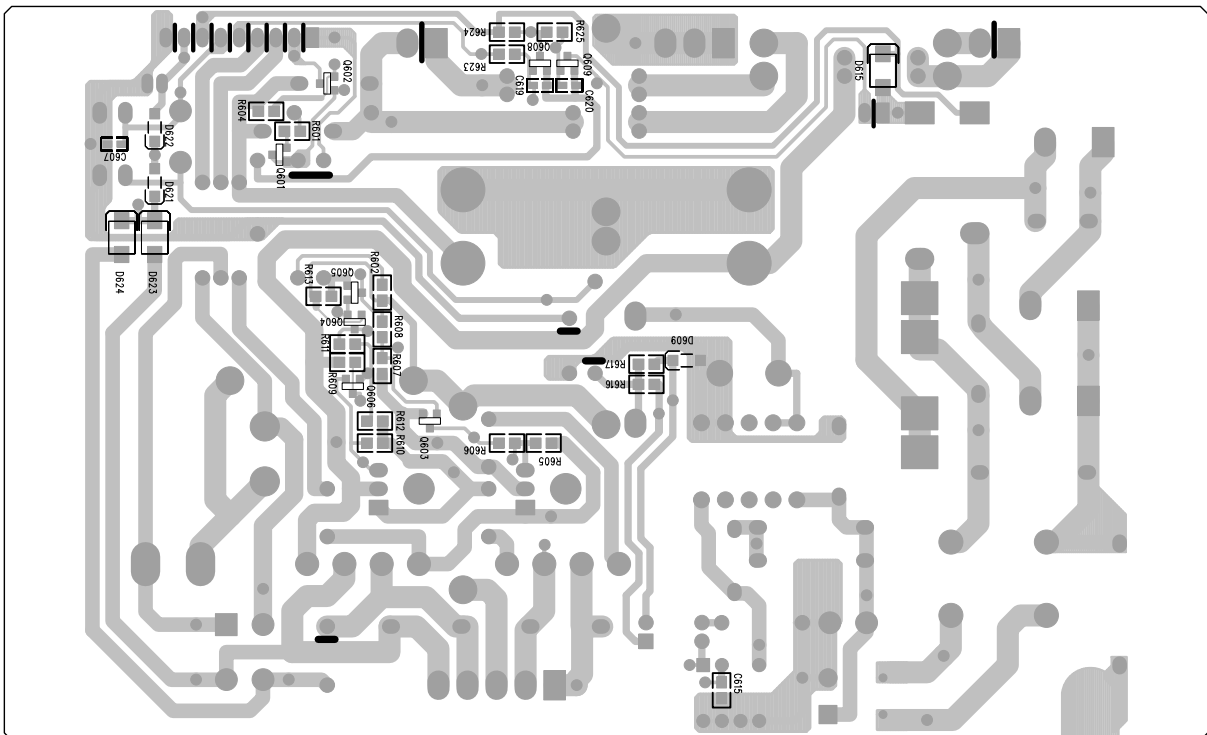

SCHEMATIC DIAGRAM

MAIN BOARD (1)

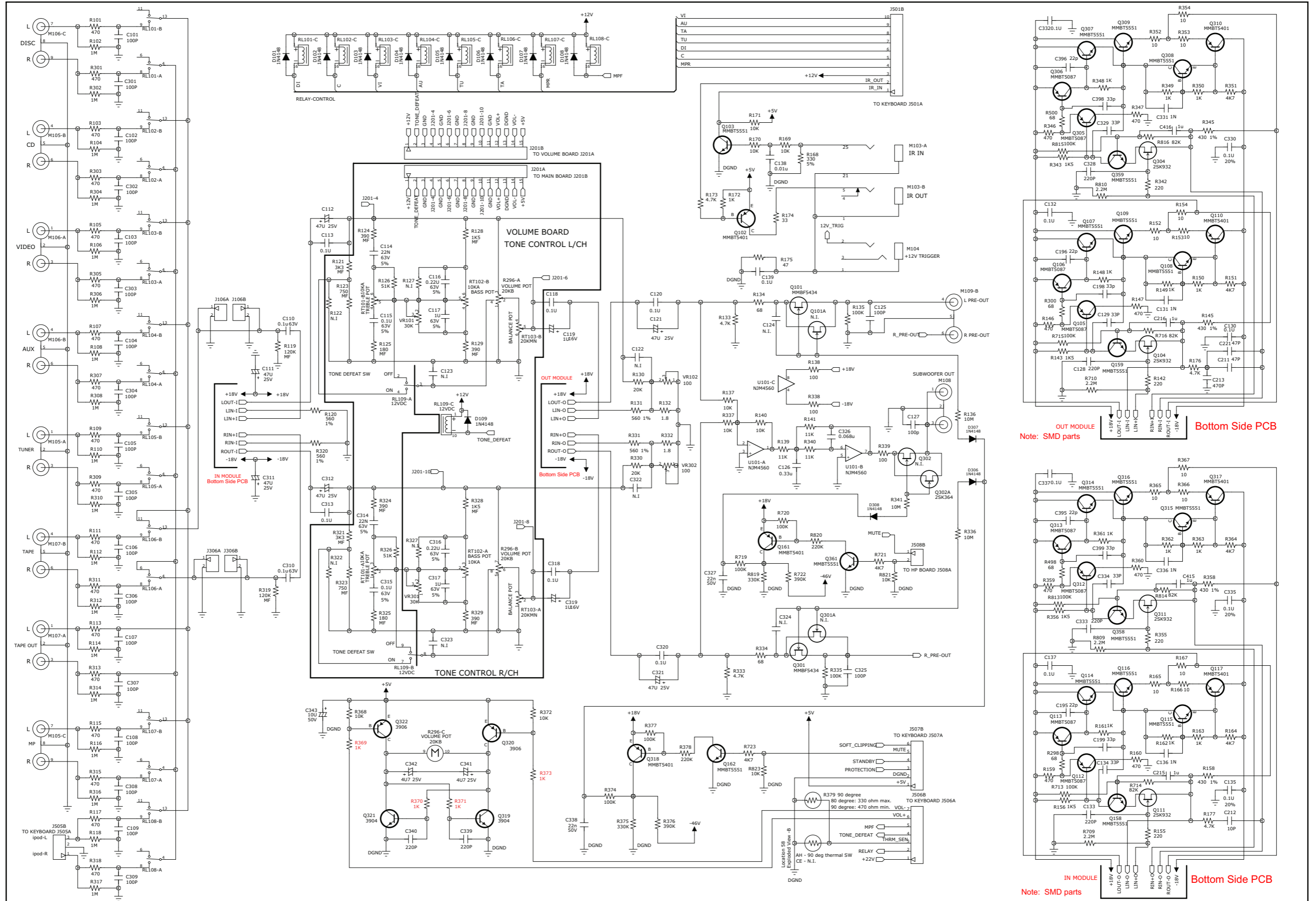

MAIN BOARD (2)

MOUNTED ON HEATSINK

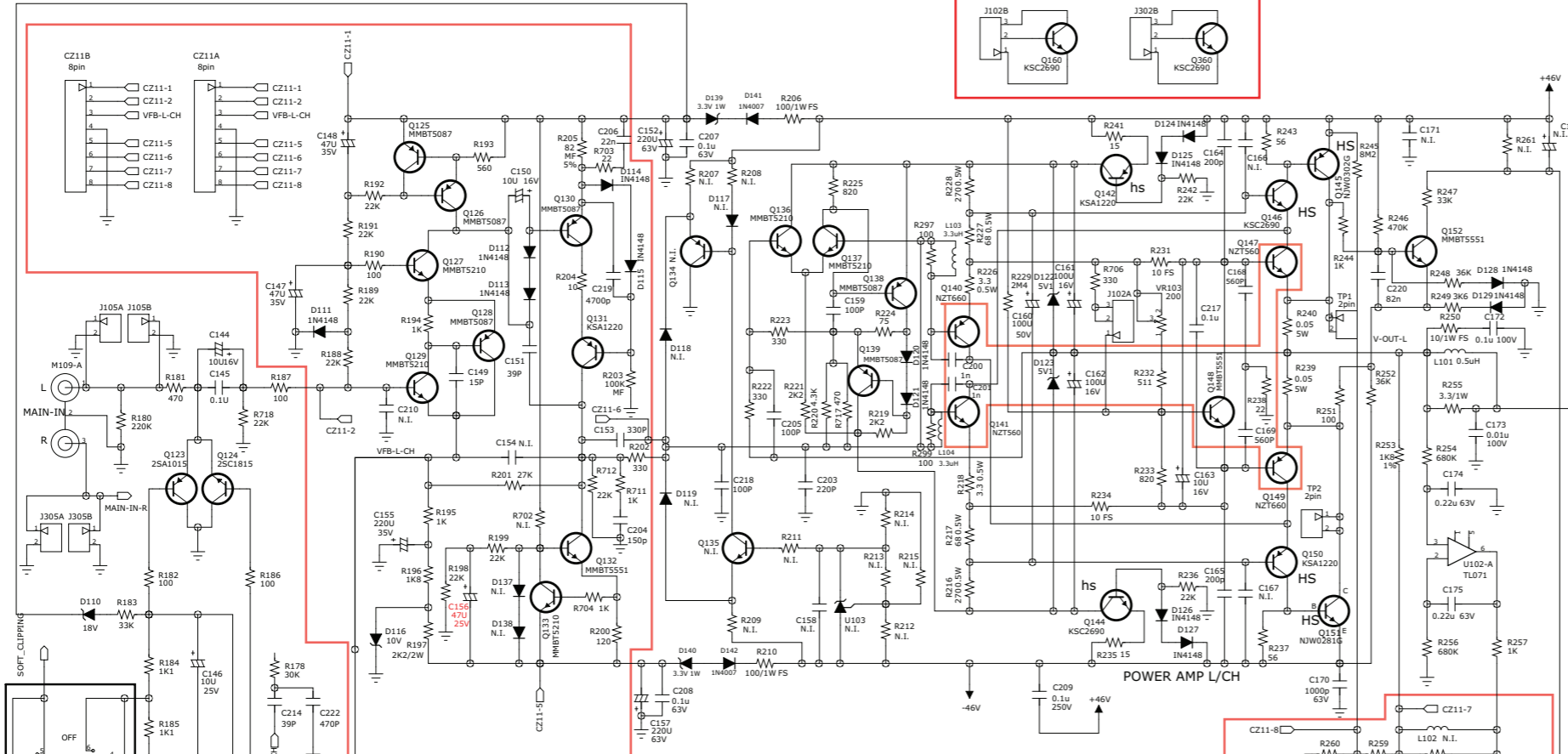
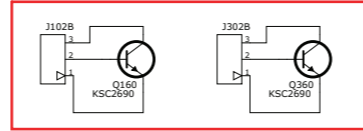

PCB MOUNTED VERTICAL 90SC326PREDVR-9021000

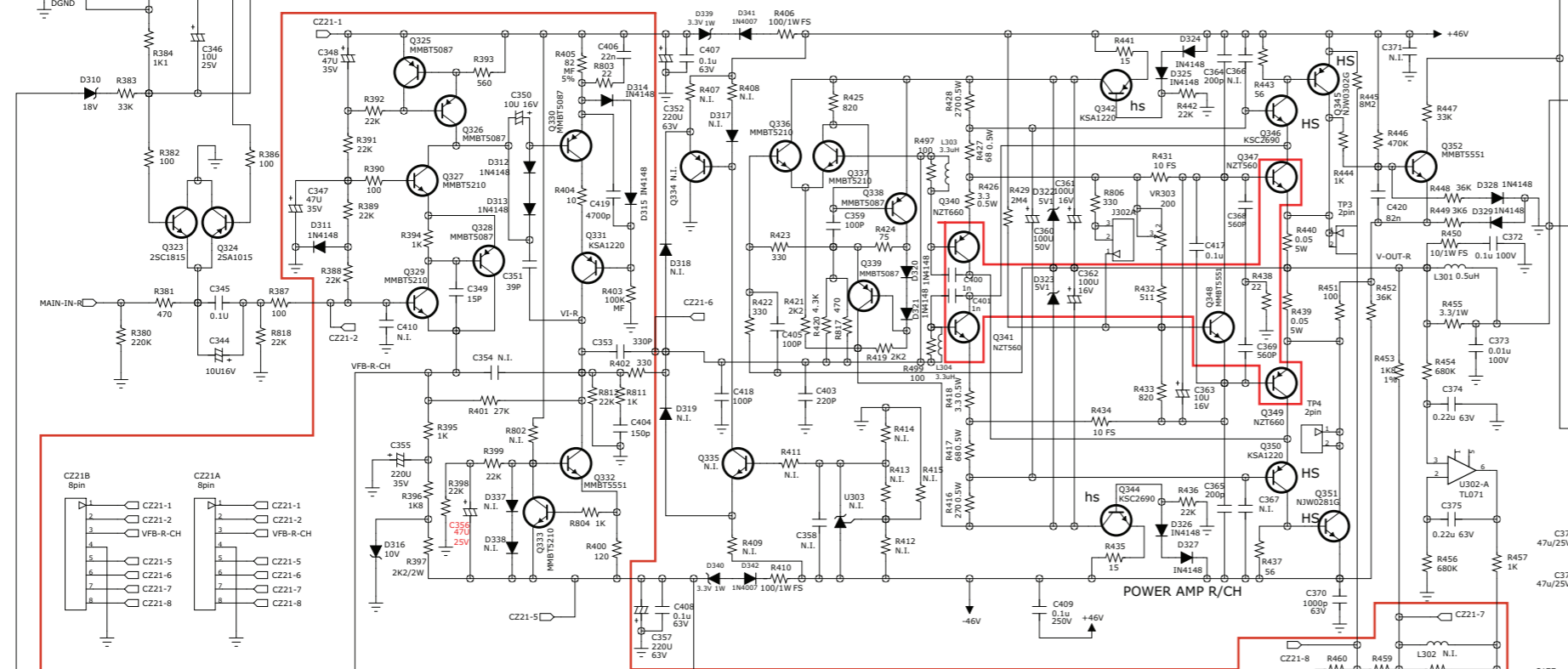

PCB MOUNTED VERTICAL 90SC326PREDVR-9021000

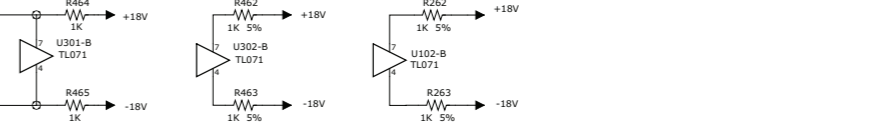
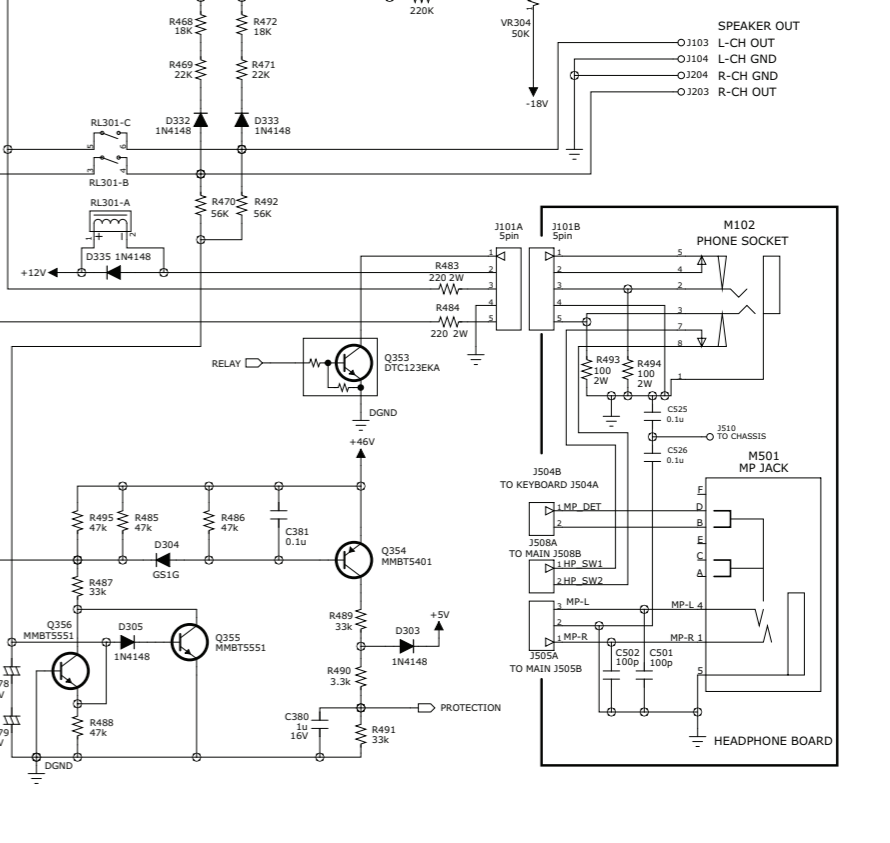
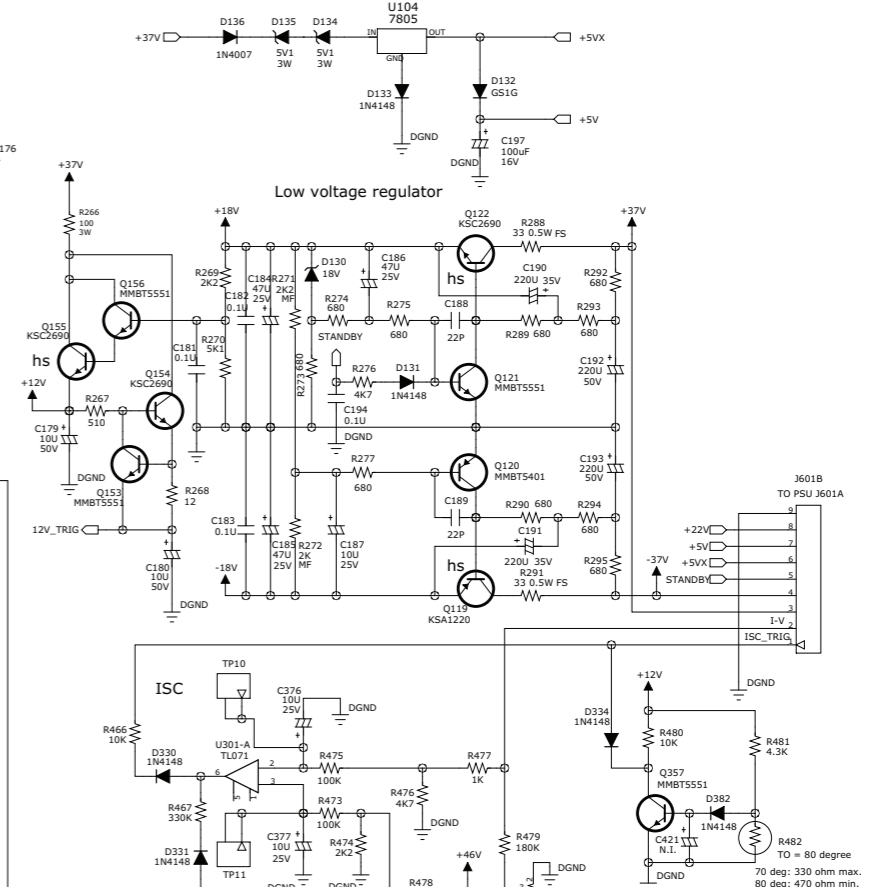

KEY BOARD

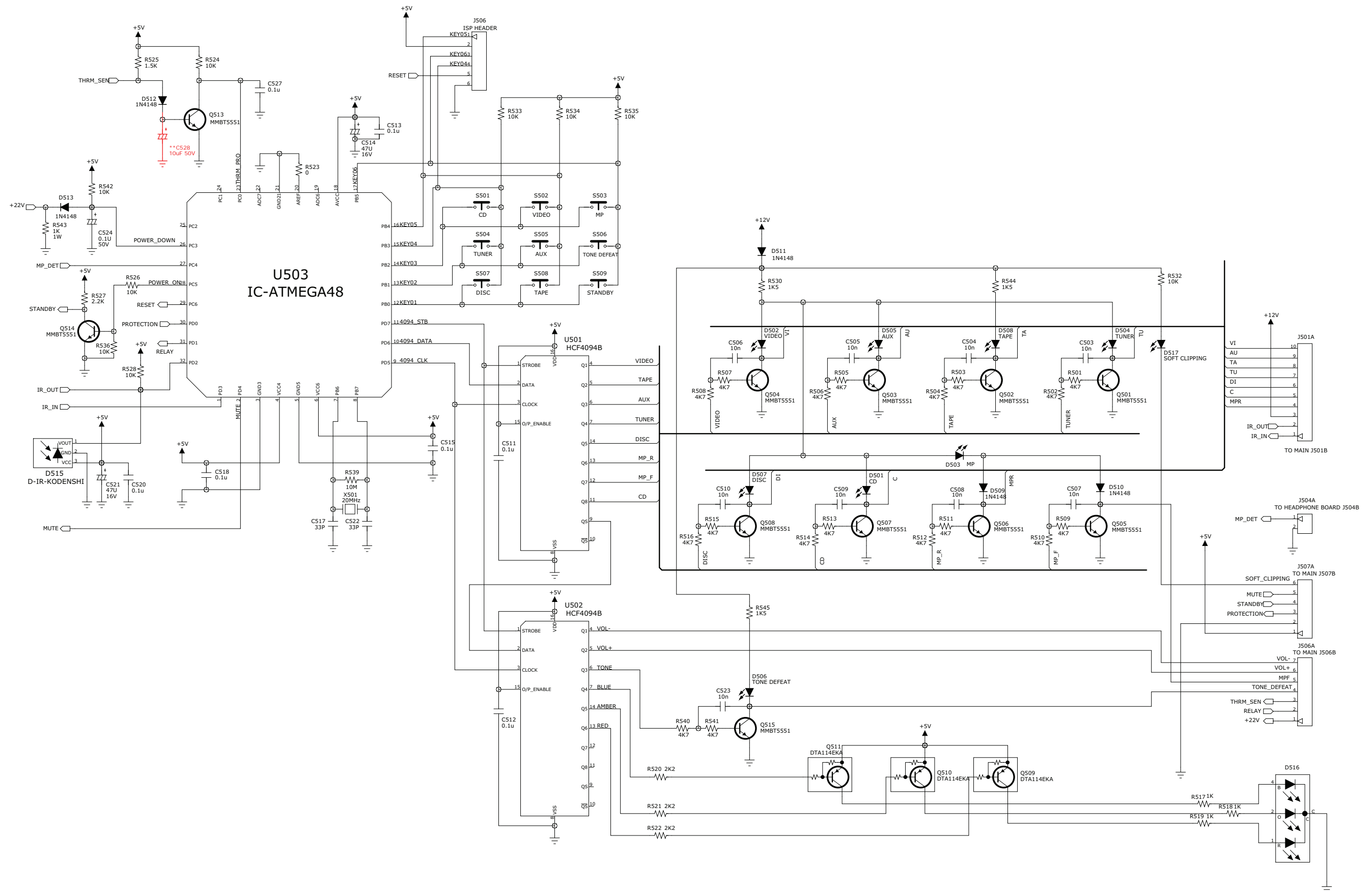

** One must add C528 to correct false "Protect" if not installed.

PSU BOARD

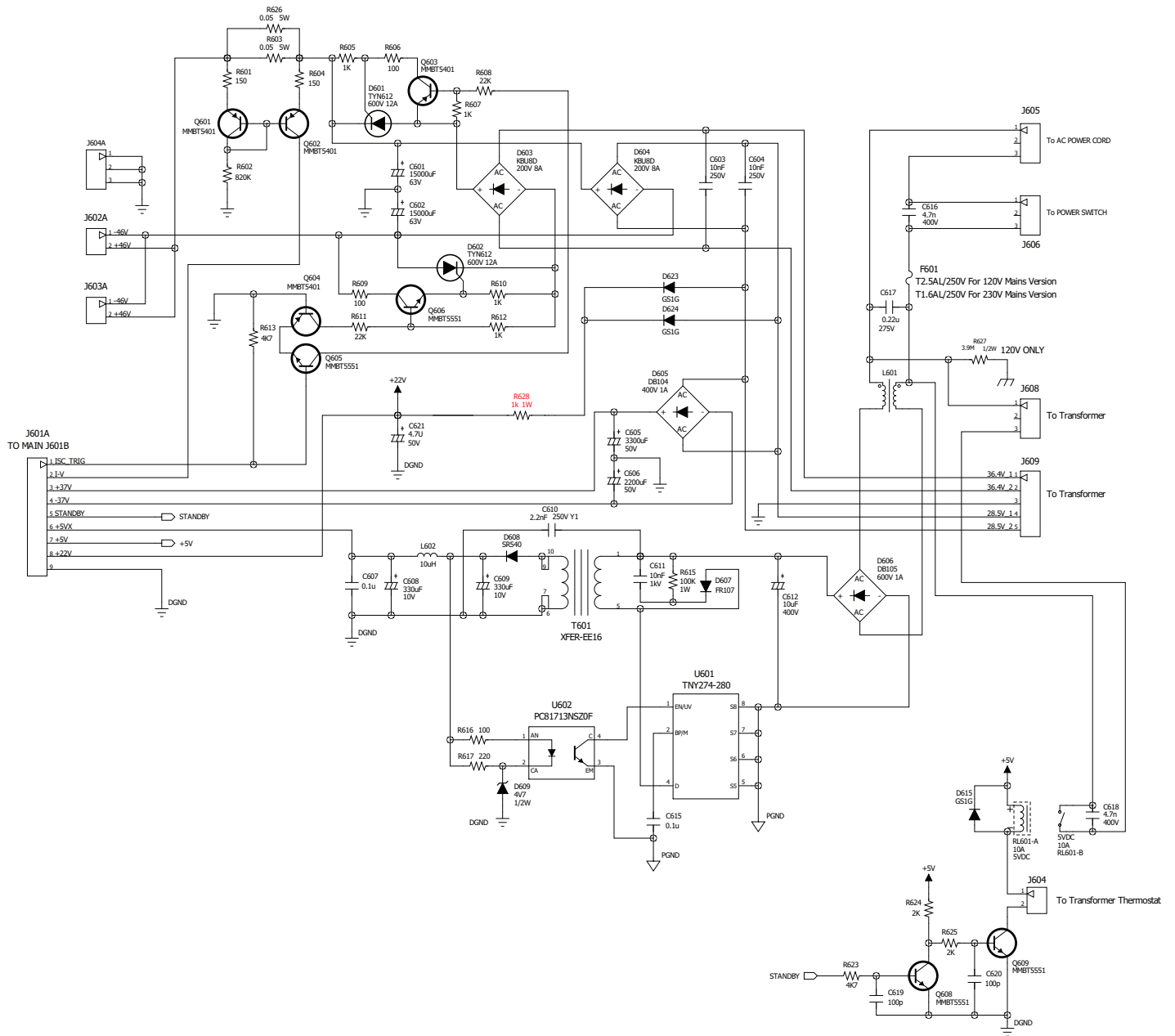

ELECTRICAL PARTS LIST

MAIN BOARD		
PCB ASSEMBLY	50-901-0326-90	C326 MAIN ASSY HFE specific (with Heatsink)
REGULATORS		
U104	01-004-0048-90	IC VOLT REG 5V 1A TO-220 NJM7805FA ISOWATT (RoHS)(JRC)
RESISTOR		
R253 R453	02-002-0172-90	RES MF 1.8K OHM 1% 1/2W AXIAL TAPE & REEL (RoHS)
R239-240 R439-440	02-005-0074-90	MPR-RES 0.05 OHM 5W 5% E TYPE 14x5x18mm (RoHS)
R250 R450	02-010-0019-90	RES MO 10 OHM 5% 1W AXIAL (RoHS)
R206 R210 R406 R410	02-010-0020-90	RES MO 100 OHM 1W 5% FLAME-PROOF AXIAL (RoHS)
R266	02-010-0027-90	RES MO 22 OHM 5% 1W AXIAL (RoHS)
R288 R291	02-010-0035-90	RES MO 33 OHM 5% 1/2W AXIAL (RoHS)
R255 R455	02-010-0038-90	RES MO 3.3 OHM 5% 1W AXIAL (RoHS)
R197 R397	02-010-0040-90	RES MO 2.2K OHM 5% 2W AXIAL (RoHS)
R483-484	02-010-0041-90	RES MO 220 OHM 5% 2W AXIAL (RoHS)
CAPACITORS		
C149 C349	03-001-0062-90	CAP CER 15pF 50V 10% NPO ST2.5 (RoHS)
C195-196 C395-396	03-001-0063-90	CAP CER 22pF 50V 10% NPO RAD (RoHS)
C128 C133 C328 C333	03-001-0064-90	CAP CER 220pF 50V 10% SL ST2.5 (RoHS)
C129 C134 C198-199 C329 C334 C398-399	03-001-0070-90	CAP CER 33pF 50V +/-10% NPO TAPE TYPE (RoHS)
C219 C419	03-001-0071-90	CAP CER CK 4700pF 50V 10% Y5P RAD ST5 CKB1H472K08BS(RoHS)
C151 C351	03-001-0076-90	CAP CER 39pF 50V 10% NPO RAD (RoHS)
C156 C356	03-xxx-xxxx-90	E CAP 47uF/25V ±20% 85°C 5x11mm P=2.0 GS (RoHS)
C161 C162 C197 C361-362	03-002-0011-90	E CAP 100uF/16V ±20% 85°C 5X11mm P=2.0 GS (RoHS)
C144 C146 C150 C163 C177 C178-180 C187 C344 C346 C350 C363 C376-377	03-002-0043-90	E CAP 10uF/50V ±20% 85°C 5x11mm P=2.0 GS (RoHS)
C111-112 C121 C147-148 C184-186 C311-312 C321 C347-348	03-002-0046-90	E CAP 47uF/50V ±20% 85°C 6.3x11mm P=2.5 GS (RoHS)
C160 C360	03-002-0047-90	E CAP 100uF/50V ±20% 85°C 8x12mm P=3.5 GS (RoHS)
C119 C319	03-002-0137-90	CAP ELEC SS 1uF 50V 20% 85C RAD HEIGHT=7mm MAX (RoHS)
C152 C157 C352 C357	03-002-0185-90	E CAP 220uF/63V ±20% 85°C 10X20mm P=5.0 GS (RoHS)
C155 C190-193 C355	03-002-0186-90	E CAP 220uF/50V ±20% 85°C 10X16mm P=5.0 GS (RoHS)
C378-379	03-002-0190-90	E CAP 47uF/25V (NP) 6.3X11mm (RoHS)
C110 C207 C208 C310 C407 C408	03-004-0031-90	MPF CAP 104J/63V 5% Mini Box 7x2.5x6.5mm P=5 (RoHS)

C174-175 C374-375	03-004-0083-90	MPF CAP 0.22uF/63V/224J 5% Mini Box 7x3.5x7.5mm P=5 (RoHS)
C173 C373	03-004-0085-90	MER CAP 0.01uF/630V/103K 10% MTC P=10 TC (RoHS)
C172 C209 C372 C409	03-004-0086-90	MER CAP 0.1uF/250V/104K 10% MTCP=10 TC (RoHS)
C170 C370	03-004-0115-90	CAP MpF 0.001uF 63V 5% DMF 5 SERIES (RoHS)
DIODES		
D136 D141-142 D341-342	04-001-0003-90	Diode 1N4007 DO-41 1A/1000V (RoHS)
D134-135	04-001-0059-90	DIODE ZENER 5.1V 3W 5% DO-41 1N5918B (RoHS)
D139-140 D339-340	04-002-0048-90	DIODE ZENER 1N4728A 3.3V 1W 5% DO-41(G) DC (RoHS)
D306-308	04-001-0001-90	Diode 1N4148 DO-35 0.15A/100V Signal Switching Diode (RoHS) <IN4148TA_NL(FSC)>
TRANSISTORS		
Q124 Q323	05-001-0072-90	Transistor SS NPN HEF 100 200MHs TO-92 C1815Y (RoHS) (YUEJING)
Q123 Q324	05-001-0080-90	Transistor SS PNP HFE 100 200MHs TO-92 A1015Y (RoHS) (YUEJING)
Q122 Q144 Q146 Q154-155 Q344 Q346	05-001-0112-90	TRANSISTOR KSC2690AYSTU NPN 1.2A/160V TO-126 FAIRCHILD (RoHS)
Q119 Q131 Q142 Q150 Q331 Q342 Q350	05-001-0113-90	TRANSISTOR KSA1220AYSTU PNP 1.2A/160V TO-126 FAIRCHILD (RoHS)
Q151 Q351	05-001-0115-90	TRANSISTOR PW NJW0281G NPN 15A/250V TO-3P ON (RoHS)
Q145 Q345	05-001-0116-90	TRANSISTOR PW NJW0302G PNP 15A/250V TO-3P ON (RoHS)
Q302A	05-001-0121-90	Transistor N-CH 2SK364-GR 40V IDSS=2.6-6.5mA TO-92 TOSHIBA (RoHS)
VARIABLE RESISTORS		
VR304	06-004-0017-90	VR SEMI-FIXED RESISTOR CF 50K OHM 30% B 6mm VERTICAL (RoHS)
VR103 VR303	06-004-0023-90	VR SEMI-FIXED RESISTOR CF 200 OHM 30% B 6mm VERTICAL (RoHS)
VR102 VR302	06-004-0024-90	VR SEMI-FIXED RESISTOR CF 100 OHM 30% B 6mm VERTICAL (RoHS)
COILS		
L101 L301	07-002-0167-90	AIR COIL 0.5uH DIA 9MM 8.5 TURNS 1MM WIRE VERTICAL EI0202NL EASE HOUSE (RoHS)
RELAYS		
RL301	07-005-0055-90	RELAY POWER DC12V 8A/250V 2P1T PCB MOUNT ME-11-012-2H4 (RoHS)
RL101-108	07-005-0062-90	RELAY DC12V 1A/125Vac 2P2T JRC-27F/012-S(555) PCB MOUNT (RoHS)
FERRITE BEADS		
Q145-B Q151-B Q345-B Q351-B	07-006-0045-90	FERRITE BEADS T4x4x2 EASE HOUSE (RoHS)
SWITCH		
SW101	11-002-0042-90	SW SLIDE 2P2T RIGHT L=9 (RoHS)

JACKS		
M104	15-002-0028-90	PHONE JACK 1 BLACK PCB MOUNT 3.5mm RIGHT(RoHS)
M103	15-002-0030-90	PHONE JACK X2 BLACK PCB MOUNT 3.5mm RIGHT ANGLE SCJ351P00YS0B00G (RoHS)
M108	15-003-0023-90	RCA JACK 2 B/B PCB MOUNT GOLD (W/SHIELD) (RoHS)
M105 M106	15-003-0035-90	RCA JACK 6 W-W-W/R-R-R PCB MOUNT GOLD W/COVER (RoHS)
M107 M109	15-003-0054-90	RCA JACK 4 W-W/R-R PCB MOUNT GOLD (W/SHIELD) (RoHS)
JUMPER BARS		
J7 J8 J9 J10 J11 J17 J19-J22 J47-J50 J52	17-016-0043-90	Jumper Bar DIA1.5 X 25 R.1(RoHS)
J12 J31 J32 J51	17-016-0044-90	JUMPER BAR DIA1.5 X 30 R.1 (RoHS)
THERMISTORS		
R379	20-004-0050-90	THERMISTOR PTC 100 OHM TS=90C PTFM04BE471Q2N34B0 (RoHS) (muRata)
R482	20-004-0051-90	THERMISTOR PTC 100 OHM TS=80C PTFM04BF471Q2N34B0 (RoHS) (muRata)
SMD ICS		
U103 U303	01-004-0069-90	IC VOLT SHUNT REG ADJ TL431-CSF SOT-23 (RoHS)
U101	01-014-0027-90	SMD IC NJM4560M SO-8 JRC Dual operational Amplifier (RoHS) <NJM4560M-TE3-#ZZZB>
U102 U301-302	01-014-0067-90	IC JFET SINGLE OP-AMP SMD TL071CDT ST (RoHS)
SMD RESISTORS		
R485 R486 R488 R495	02-007-0026-90	SMD RES 47K OHM 1/10W 5% 0805 2.0X1.25X0.55 (RoHS)
R148-149 R150 R161-162 R163 R172 R194 R195 R207-209 R212 R244 R257 R262-263 R704 R711 R348-349 R350 R361-362 R363 R394-395 R407-409 R412 R444 R457 R462-465 R477 R804 R811 R271	02-007-0042-90	SMD RES 1K OHM 0603 5% (RoHS)
R183 R247 R383 R447	02-007-0136-90	SMD RES 33K OHM 0603 5% (RoHS)
R180 R378 R380 R478 R820	02-007-0137-90	SMD RES 220K OHM 0603 5% (RoHS)
R133 R151 R164 R173 R176 R177 R276 R333 R351 R364 R476 R721 R723 R138 R182 R186-187 R190 R211 R251 R258 R297 R299 R338-339 R382 R386-387 R390 R411 R451 R458 R497 R499 R468 R472	02-007-0139-90	SMD RES 4.7K OHM 0603 5% (RoHS)
R188-189 R191-192 R198 R199 R236 R242 R388-389 R391-392 R398 R399 R436 R442 R469 R471 R712 R718 R812 R818	02-007-0143-90	SMD RES 18K OHM 5% 1/16W 0603 TAPE (RoHS)
	02-007-0145-90	SMD RES 22K OHM 0603 5% (RoHS)

R213 R413	02-007-0147-90	SMD RES 5.6K OHM 0603 5% (RoHS)
R196 R396	02-007-0149-90	SMD RES 1.8K OHM 0603 5% (RoHS)
R152-154 R165-167 R204 R231 R234 R352-354 R365-367 R404 R431 R434	02-007-0151-90	SMD RES 10 OHM 0603 5% (RoHS)
R220 R420 R481	02-007-0152-90	SMD RES 4.3K OHM 0603 5% (RoHS)
R119 R319	02-007-0155-90	SMD RES 120K OHM 0603 5% (RoHS)
R137 R140 R169-171 R337 R466 R480 R821 R823	02-007-0157-90	SMD RES 10K OHM 0603 1% (RoHS)
R214-215 R414-415	02-007-0237-90	SMD RES 10K OHM 1/4W 1% 1206 TAPE (RoHS)
R135 R203 R335 R374 R377 R403 R473 R475 R713 R715 R719-720 R813 R815 R470 R492	02-007-0267-90	SMD RES 100K OHM 5% 1/16W 0603 TAPE (RoHS)
R168 R202 R222-223 R402 R422-423 R706 R806	02-007-0270-90	SMD RES 330 OHM 1% 1/16W 0603 TAPE (RoHS)
R102 R104 R106 R108 R110 R112 R114 R116 R118 R302 R304 R306 R308 R310 R312 R314 R316-317 R175	02-007-0271-90	SMD RES 1M OHM 5% 1/16W 0603 TAPE (RoHS)
R134 R259 R334 R459 R298 R300 R498 R500	02-007-0289-90	RES SMD 47 OHM 5% 1/4W 1206 TAPE (RoHS)
R219 R221 R269 R419 R421 R474	02-007-0289-90	RES SMD 68 OHM +/-1% 1/16W 0603 TAPE (RoHS)
R174	02-007-0292-90	RES SMD 2.2K OHM 1% 1/16W 0603 TAPE (RoHS)
R101 R103 R105 R107 R109 R111 R113 R115 R117 R146 R147 R159 R160 R181 R301 R303 R305 R307 R309 R311 R313 R315 R318 R346-347 R359-360 R381 R120 R131 R193 R320 R331 R393	02-007-0293-90	RES SMD 33 OHM 5% 1/16W 0603 TAPE (RoHS)
R273-275 R277 R289-290 R292-295	02-007-0294-90	RES SMD 470 OHM 5% 1/16W 0603 TAPE (RoHS)
R136 R336 R341	02-007-0297-90	RES SMD 560 OHM +/-1% 1/16W 0603 TAPE (RoHS)
R130 R330	02-007-0298-90	RES SMD 680 OHM 5% 1/16W 0603 TAPE (RoHS)
R490	02-007-0299-90	RES SMD 10M OHM +/-5% 1/16W 0603 TAPE (RoHS)
R254 R256 R454 R456	02-007-0312-90	RES SMD 20K OHM 1/16W 1% 0603 TAPE(RoHS)
R200 R400	02-007-0321-90	RES SMD 3.3K OHM 1% 1/16W 0603 TAPE(RoHS)
R487 R489 R491	02-007-0333-90	RES SMD 680K OHM 5% 1/16W 0603 TAPE(RoHS)
R246 R446	02-007-0341-90	RES SMD 120 OHM 5% 1/16W 0603 TYPE (RoHS)
R270	02-007-0347-90	RES SMD 33K OHM 5% 1/10W 0805 TYPE (RoHS)
R224 R424	02-007-0352-90	RES SMD 200K OHM +/-5% 1/16W 0603 TAPE (RoHS)
R143 R156 R343 R356	02-007-0354-90	RES SMD 5.1K OHM 5% 1/16W 0603 TYPE (RoHS)
R142 R155 R342 R355	02-007-0357-90	RES SMD 75 OHM 5% 1/16W 0603 TYPE (RoHS)
R717 R817	02-007-0368-90	RES SMD 1.5K OHM 5% 1/16W 0603 TAPE(RoHS)
	02-007-0372-90	RES SMD 220 OHM 5% 1/16W 0603 TAPE(RoHS)
	02-007-0416-90	SMD RES 470 OHM 1% 1/16W 0603 TAPE (RoHS)

R268	02-007-0436-90	RES SMD 12 OHM +/-5% 1/16W 0603 TYPE (ROHS)
R709 R710 R809 R810	02-007-0441-90	RES SMD 2.2M OHM 5% 1/10W 0805 TYPE (RoHS)
R178	02-007-0444-90	RES SMD 30K OHM 5% 1/16W 0603 TAPE (RoHS)
R225 R233 R425 R433	02-007-0445-90	RES SMD 820 OHM 5% 1/16W 0603 TAPE (RoHS)
R267	02-007-0446-90	RES SMD 510 OHM 5% 1/16W 0603 TAPE (RoHS)
R132 R332	02-007-0557-90	SMD RES 1.8 OHM 5% 1/16W 0603 TAPE(RoHS)
R184-185 R384-385	02-007-0558-90	SMD RES 1.1K OHM 5% 1/16W 0603 TAPE (RoHS)
R245 R445	02-007-0559-90	SMD RES 8.2M OHM 5% 1/16W 0603 TAPE (RoHS)
R260 R460	02-007-0560-90	RES SMD 1 OHM 5% 1/16W 0603 TAPE (RoHS)
R139 R141 R340	02-007-0561-90	SMD RES 11K OHM 5% 1/16W 0603 TAPE (RoHS)
R235 R241 R435 R441	02-007-0562-90	SMD RES 15 OHM 5% 1/16W 0603 TAPE (RoHS)
R238 R703 R438 R803	02-007-0563-90	SMD RES 22 OHM 5% 1/16W 0603 TAPE (RoHS)
R272	02-007-0564-90	SMD RES 2K OHM 1/4W 1206 5% (RoHS)
R229 R429	02-007-0565-90	SMD RES 2.4M OHM 5% 1/16W 0603 TAPE (RoHS)
R375 R467 R819	02-007-0566-90	SMD RES 330K OHM 5% 1/16W 0603 TAPE (RoHS)
R479	02-007-0568-90	SMD RES 180K OHM 5% 1/16W 0603 TAPE (RoHS)
R376 R722	02-007-0570-90	SMD RES 390K OHM 5% 1/16W 0603 TAPE (RoHS)
R248 R252 R448 R452	02-007-0572-90	SMD RES 36K OHM 5% 1/16W 0603 TAPE (RoHS)
R249 R449	02-007-0573-90	SMD RES 3.6K OHM 5% 1/16W 0603 TAPE (RoHS)
R216 R228 R416 R428	02-007-0578-90	SMD RES 270 OHM 5% 1/2W 2010 TAPE (RoHS)
R217 R227 R417 R427	02-007-0579-90	SMD RES 68 OHM 5% 1/2W 2010 TAPE (RoHS)
R218 R226 R418 R426	02-007-0580-90	SMD RES 3.3 OHM 5% 1/2W 2010 TAPE (RoHS)
R232 R432	02-007-0586-90	SMD RES 511 OHM 1% 1/16W 0603 TAPE (RoHS)
R205 R405	02-007-0670-90	SMD RES 82 OHM 5% 1/4W 1206 TAPE (RoHS)
R201 R401	02-007-0675-90	SMD RES 27K OHM 5% 1/16W 0603 TAPE (RoHS)
R145 R158 R345 R358	02-007-0677-90	RES SMD 430 OHM 1% 1/16W 0603 TAPE (RoHS)
R714 R716 R814 R816	02-007-0678-90	RES SMD 82K OHM 5% 1/16W 0603 TAPE (RoHS)
R237 R243 R437 R443	02-007-0681-90	RES SMD 56 OHM 5% 1/4W 1206 TAPE (ROHS)
SMD CAPACITORS		
C113 C118 C120 C130 C132 C135 C137 C145 C158 C181-183 C194 C217 C313 C318 C320 C330 C332 C335 C337 C345 C358 C381 C417	03-009-0075-90	CAP CER SMD 0.1uF 50V 20% Y5V 0603 TAPE

C211 C221	03-009-0078-90	SMD CER CAP 47pF/50V 10% NPO 0603 TAPE (RoHS)
C215 C216 C380 C415 C416	03-009-0081-90	SMD CER CAP 1uF/25V 20% Y5V 1206 TAPE (RoHS)
C139	03-009-0105-90	CAP CER SMD 0.1uF 50V 10% X7R 1206 TAPE (RoHS)
C214	03-009-0108-90	CAP CER SMD 39pF 50V +10% NPO 0603 TAPE (RoHS)
C101-109 C125 C127 C159 C205 C218 C301-309 C325 C359 C405 C418	03-009-0111-90	CAP CER SMD 100pF 50V 10% X7R 0603 TAPE (RoHS)
C131 C136 C200 C201 C331 C336 C400 C401	03-009-0112-90	CAP CER SMD 1nF 50V 10% X7R 0603 TAPE (RoHS)
C138	03-009-0113-90	CAP CER SMD 10nF 50V 10% X7R 0603 TAPE (RoHS)
C203 C403	03-009-0114-90	CAP CER SMD 220pF 50V 10% X7R 0603 TAPE (RoHS)
C153 C353	03-009-0117-90	CAP CER SMD 330pF 50V 10% X7R 0603 TAPE (RoHS)
C212	03-009-0124-90	CAP CER SMD 10pF 50V 5% NPO 0603 TAPE (RoHS)
C164-165 C364-365	03-009-0125-90	CAP CER SMD 100pF 100V 10% X7R 0805 TAPE (RoHS)
C204 C404	03-009-0129-90	CAP CER SMD 150pF 100V +/-5% NPO 0603 TAPE (RoHS)
C188 C189	03-009-0130-90	CAP CER SMD 22pF 50V 5% COG 0603 TAPE (ROHS)
C206 C327 C338 C406	03-009-0131-90	CAP CER SMD 22nF 50V 20% Y5V 0603 TAPE (ROHS)
C213 C222	03-009-0133-90	CAP CER SMD 470pF 50V 5% NPO 0603 TAPE (ROHS)
C168 C169 C368 C369	03-009-0157-90	CAP CER SMD 560pF 50v 10% X7R 0603 TAPE (RoHS)
C126	03-009-0259-90	CAP CER SMD 0.33uF 50V 10% X7R 0805 TAPE (RoHS)
C326	03-009-0260-90	CAP CER SMD 68nF 50V 10% X7R 0805 TAPE (RoHS)
C220 C420	03-009-0280-90	CAP CER SMD 0.082uF 50V 10% X7R 0603 TAPE (RoHS)
SMD DIODES		
D132 D304	04-006-0019-90	DIODE RECT 1A/400V DO-214AC SMD GS1G M4 GS1G (DC) (RoHS)
D101-108 D111-115 D117-121 D124-129 D131 D133 D303 D305 D311-315 D317-321 D324-335 D382	04-006-0021-90	SMD DIODE LL4148 SOD80 (VISHAY) (RoHS)
D110 D130 D310	04-007-0040-90	DIODE ZENER SMD 18V 500mW 5% SOD123 MMSZ5248B (RoHS) (DC)
D122-123 D322-323	04-007-0041-90	DIODE ZENER SMD 5.1V 500mW 5% SOD123 (RoHS)
D116 D316	04-007-0046-90	DIODE ZENER SMD 10V 500mW 5% SOD123 MMSZ5240B (RoHS)
SMT TRANSISTORS		
Q103 Q107-109 Q114-116 Q121 Q132 Q148 Q152-153 Q156 Q158-159 Q162 Q307-309 Q314-316 Q332 Q348 Q352 Q355-357 Q358-359 Q361	05-004-0018-90	SMD Transistor MMBT5551LT1G NPN SOT-23 (ON) (RoHS)
Q102 Q110 Q117 Q120 Q161 Q310 Q317-318 Q354	05-004-0019-90	SMD Transistor MMBT5401LT1G PNP SOT-23 (ON) (RoHS)

Q353	05-004-0036-90	TRANSISTOR SS NPN HFE20 250MHz DTC123EKAT146(RoHS) (ROHM)
Q127 Q129 Q133 Q135-137 Q327 Q329 Q333 Q335-337	05-004-0065-90	SMD TRANSISTOR MMBT5210 NPN SMD SOT-23 FAIRCHILD (RoHS)
Q141 Q147 Q341 Q347	05-004-0066-90	SMD TRANSISTOR NZT560 NPN 3A/60V SMD SOT-223 FAIRCHILD (RoHS)
Q105-106 Q112-113 Q125-126 Q128 Q130 Q134 Q138-139 Q305-306 Q312-313 Q325-326 Q328 Q330 Q334 Q338-339	05-004-0067-90	SMD TRANSISTOR MMBT5087 PNP SMD SOT-23 FAIRCHILD (RoHS)
Q140 Q149 Q340 Q349	05-004-0068-90	SMD TRANSISTOR NZT660 PNP 3A/60V SMD SOT-223 FAIRCHILD (RoHS)
Q104 Q111 Q304 Q311	05-004-0076-90	XTR N-CH 2SK932-21 15V IDSS=5.0- 8.5mA SMD SANYO (RoHS)
Q101 Q301	05-004-0077-90	SMD Transistor N-CH MMBF5434 25V IDSS=30mA SMD FAIRCHILD (RoHS)
SMD INDUCTOR		
L103-104 L303-304	07-007-0021-90	IND SMD 3.3uH 10% 0805 (RoHS)
JUMPERS		
JMP2 JMP3 JMP5-6 JMP10-11 JMP15-20 JMP24 JMP27-29 JMP32-33 JMP36-37 JMP40-44 JMP48 JMP50-53 JMP61-64 JMP66 JMP72-74 JMP76 JMP82 JMP84 JMP88-89 JMP95 JMP98-101 JMP104-105 JMP107-109 JMP116-120 JMP126-128 JMP132 JMP136-138 JMP141 JMP148 JMP150-151 JMP153 JMP156-157 JMP162 JMP164-165 JMP167 JMP172 JMP174 JMP177 JMP180 JMP184-186 JMP191-192 JMP197 JMP201 JMP202 JMP205-207 JMP229 JMP231 JMP237 JMP239 JMP243-244 JMP247-248 JMP251-252 JMP254-255 JMP267 JMP275-277	17-016-0077-90	Jumper wire Dia. 0.5mm L=52.0mm (RoHS)
JMP1 JMP4 JMP7 JMP8 JMP9 JMP13-14 JMP21 JMP23 JMP25 JMP30 JMP31 JMP34-35 JMP38-39 JMP45-47 JMP49 JMP54-59 JMP65 JMP67-68 JMP71 JMP75 JMP77-81 JMP83 JMP86-87 JMP90-94 JMP96-97 JMP102-103 JMP106 JMP110-115 JMP121-125 JMP133-135 JMP139-140 JMP142-143 JMP145-146 JMP149 JMP152 JMP154-155 JMP158-161 JMP163 JMP166 JMP169-170 JMP173 JMP175-176 JMP178-179 JMP181-183 JMP187-188 JMP190 JMP193-196 JMP199-200 JMP203-204 JMP208 JMP221 JMP230 JMP232-233 JMP235-236 JMP238 JMP241-242 JMP245-246 JMP249-250 JMP253 JMP256-265 JMP268-274 JMP278-280	17-016-0080-90	Jumper Wire Dia. 0.6mm For L Smaller than 14mm Roll (RoHS)

PSU BOARD**PCB ASSEMBLY *AH****50-903-0326-90****C326 AH PSU ASSY****PCB ASSEMBLY *C,CT****50-904-0326-90****C326 C/CT PSU ASSY****ICS**

U601

01-003-0104-90

IC TINYSWITCH-III TNY274PN DIP-8C

U602

01-006-0033-90

IC FOD817C300 OPTOCOUPLER
FAIRCHILD (RoHS)**RESISTORS**

R627

02-001-0451-90

RES CONDUCTIVE PATH 3.9M OHM
1/2W 5% RNV1/2 395J (RoHS)

R603 R626

02-005-0074-90

MPR-RES 0.05 OHM 5W 5% E TYPE
14x5x18mm (RoHS)

R615

02-010-0039-90

RES MO 100K OHM 5% 1W AXIAL(RoHS)

CAPACITORS

C606

03-002-0084-90

E CAP 2200uF/50V ±20% 85°C 16X35mm
P=7.5 GS (RoHS)

C621

03-002-0148-90

CAP ELEC SS 4.7uF 50V 20% 85C RAD
HEIGHT=7mm MAX (RoHS)

C601-602

03-002-0187-90

E CAP 15000uF/50V ±20% 85°C 35x50mm
P=10 LP (RoHS)

C605

03-002-0188-90

E CAP 3300uF/50V ±20% 85°C 18x35mm
P=7.5 GS (RoHS)

C612

03-002-0189-90

E CAP 10uF/400V ±20% 105°C 10x20mm
P=5.0 SK (RoHS)

C608-609

03-002-0195-90

E CAP 330uF 16V 20% 105°C 8x12mm
LOW IMPEDANCE GL KSC (RoHS)

C603-604

03-004-0085-90

MER CAP 0.01uF/630V/103K 10% MTC
P=10 TC

C617

03-004-0139-90

MEX CAP 0.22uF/275VAC X2 UL/CSA/VDE
(RoHS)

C611

03-004-0144-90

FILM CAP 0.01uF 1000V 10% P=15 PPN
MATRONIC (RoHS)

C616 C618

03-007-0022-90

CER CAP 4700pF/250VAC ±20% Y5V RAD
JY12F472MK02 Y2 UL/CSA/VDE (RoHS)

C610

03-007-0023-90

HC CER CAP 2200pF/440VAC ±20% Y1/X1
JN UL/CSA/VDE (RoHS)**DIODES**

D601-602

04-001-0046-90

Diode Rect 12A/600V TO-220 TYN612
(RoHS) (ST)

D607

04-001-0053-90

DIODE FR107 1A/1000V DO-41 FAST
RECOVERY (RoHS)

D608

04-002-0068-90

SCHOTTKY DIODE SR540 5A/40V DO-27
(RoHS)

D603-604

04-005-0027-90

DIODE BRI 8A/200V KBU8D (DC) (RoHS)

D605

04-005-0028-90

DIODE BRI 1A/400V DB104 (DC) (RoHS)

D606

04-005-0029-90

DIODE BRI 1A/600V DB105 (DC) (RoHS)

COIL

L602

07-002-0161-90

IND COIL RADIAL 10uH 20% 22.5T
RC5X25-100M EASE HOUSE(RoHS)**RELAY**

RL601

07-005-0063-90

RELAY MINIATURE 5VDC/10A 1P1T
TV-5 ME-7-005-HL MASSUSE (RoHS)

CHOKE		
L601	07-008-0002-90	LINE CHOKE 4 PIN 250VAC UL BASE (RoHS)
TRANSFORMER		
T601 C326	10-005-0295-90	TRANSFORMER SWITCHING EE16
FUSE		
F601 *AH	20-001-0086-90	FUSE 3.15A 250V TIME LAG LBC 5x20mm TSD UL/CSA/VDE/SEMKO (RoHS)
F601 *C/CT	20-001-0076-90	FUSE 1.6A 250V TIME LAG LBC 5X20mm TSD UL/CSA/VDE/SEMKO (RoHS)
SMD RESISTORS		
R605 R607 R610 R612	02-007-0042-90	SMD RES 1K OHM 0603 5% (RoHS)
R613 R623	02-007-0139-90	SMD RES 4.7K OHM 0603 5% (RoHS)
R609 R606 R616	02-007-0141-90	SMD RES 100 OHM 0603 5% (RoHS)
R608 R611	02-007-0145-90	SMD RES 22K OHM 0603 5% (RoHS)
R601 R604	02-007-0291-90	RES SMD 150 OHM 5% 1/16W 0603 TAPE (RoHS)
R617	02-007-0372-90	RES SMD 220 OHM 5% 1/16W 0603 TAPE(RoHS)
R624-625	02-007-0392-90	RES SMD 2K OHM 5% 1/16W 0603 TAPE (RoHS)
R602	02-007-0448-90	RES SMD 820K OHM 5% 1/16W 0603 TAPE (RoHS)
SMD CAPACITORS		
C607 C615	03-009-0075-90	CAP CER SMD 0.1uF 50V 20% Y5V 0603 TAPE
C619-620	03-009-0111-90	CAP CER SMD 100pF 50V 10% X7R 0603 TAPE (RoHS)
SMD DIODES		
D615 D623 D624	04-006-0019-90	DIODE RECT 1A/400V DO-214AC SMD GS1G M4 GS1G (DC) (RoHS)
D621 D622 Replaced with R628	See schematic	1Kohm 1W leaded resistor (RoHS)
D609	04-007-0063-90	DIODE ZENER SMD 4.7V 500mW 5% SOD123 MMSZ5230B (RoHS) (DC)
SMD TRANSISTORS		
Q605-606 Q608-609	05-004-0018-90	SMD Transistor MMBT5551LT1G NPN SOT-23 (ON) (RoHS)
Q601-604	05-004-0019-90	SMD Transistor MMBT5401LT1G PNP SOT-23 (ON) (RoHS)
JUMPERS		
JMP2 JMP4-5 JMP19	17-016-0077-90	Jumper wire Dia. 0.5mm L=52.0mm (RoHS)
JMP1 JMP3 JMP6-18 JMP20	17-016-0080-90	Jumper Wire Dia. 0.6mm For L Smaller than 14mm Roll (RoHS)
VOLUME BOARD		
PCB ASSEMBLY	50-914-0326-90	C326 AH VOLUME ASSY

CAPACITORS		
C341 C342	03-002-0042-90	E CAP 4.7uF/50V ±20% 85°C 5x11mm P=2.0 GS (RoHS)
C343	03-002-0043-90	E CAP 10uF/50V ±20% 85°C 5x11mm P=2.0 GS (RoHS)
C115 C315	03-004-0031-90	MPF CAP 104J/63V 5% Mini Box 7x2.5x6.5mm P=5 (RoHS)
C116 C316	03-004-0083-90	MPF CAP 0.22uF/63V/224J 5% Mini Box 7x3.5x7.5mm P=5 (RoHS)
C117 C317	03-004-0090-90	MPF CAP 1uF/63V/105J 5% Mini Box 7x6x11mm P=5 (RoHS)
C114 C314	03-004-0113-90	MPF CAP 0.022uF/63V ±5% DMF 5 SERIES (RoHS)
VRS		
RT101-102	06-002-0065-90	VR ROTARY POTENTIOMETER 10KAX2 L=20mm W/CC RV16A01F-20-20F-A10K-3C (RoHS)
RT103	06-002-0066-90	VR ROTARY POTENTIOMETER 20KMNX2 L=20mm W/CC RV16A01F-20-20F-MN20K-3C (RoHS)
R296	06-002-0068-90	MOTOR POTENTIOMETER 20KBX2 L=20MM WITH NUTS RK16812MG SAMPLE NO F6531071M ALPS (RoHS)
VR101 VR301	06-004-0022-90	VR SEMI-FIXED RESISTOR CF 30K OHM 30% B 6mm VERTICAL (RoHS)
RELAY		
RL109	07-005-0053-90	RELAY DC12V 0.5A/125V ME-12-12 MINIATURE PCB MOUNT (RoHS)
SMD RESISTORS		
R368 R372	02-007-0157-90	SMD RES 10K OHM 0603 1% (RoHS)
R121 R321	02-007-0321-90	RES SMD 3.3K OHM 1% 1/16W 0603 TAPE(RoHS)
R128 R328	02-007-0368-90	RES SMD 1.5K OHM 5% 1/16W 0603 TAPE(RoHS)
R124 R129 R324 R329	02-007-0369-90	RES SMD 390 OHM 5% 1/16W 0603 TAPE(RoHS)
R125 R325	02-007-0391-90	RES SMD 180 OHM 5% 1/16W 0603 TAPE (RoHS)
R123 R323	02-007-0567-90	SMD RES 750 OHM 1% 1/16W 0603 TAPE (RoHS)
R126 R326	02-007-0569-90	SMD RES 51K OHM 5% 1/16W 0603 TAPE (RoHS)
R369-371 R373	02-007-0xxx-90	RES SMD 1000 OHM 1/8W 0805 5% TAPE (RoHS)
SMD CAPACITORS		
C339-340	03-009-0114-90	CAP CER SMD 220pF 50V 10% X7R 0603 TAPE (RoHS)
SMD DIODE		
D109	04-006-0021-90	SMD DIODE LL4148 SOD80 (VISHAY) (RoHS)
SMD TRANSISTORS		
Q319 Q321	05-004-0018-90	SMD Transistor MMBT5551LT1G NPN SOT-23 (ON) (RoHS)
Q320 Q322	05-004-0019-90	SMD Transistor MMBT5401LT1G PNP SOT-23 (ON) (RoHS)

JUMPERS

JMP209-210 JMP212-213 JMP222-223 JMP226-228	17-016-0077-90	Jumper wire Dia. 0.5mm L=52.0mm (RoHS)
JMP144 JMP189 JMP211 JMP214-220 JMP224-226 J1/MOTOR J2/MOTOR	17-016-0080-90	Jumper Wire Dia. 0.6mm For L Smaller than 14mm Roll (RoHS)

KEYBOARD**PCB ASSEMBLY****50-922-0326-90****C326 KEYBOARD ASSY****CAPACITORS**

C514 C521	03-002-0010-90	E CAP 47uF/16V ±20% 85°C 5x11mm P=2.0 GS (RoHS)
C524	03-002-0138-90	CAP ELEC SS 0.1uF 50V 20% 85C RAD HEIGHT=7mm (RoHS)

IR RECEIVER

D515	04-009-0003-90	IR RX 37.9kHz SHIELD RT FM-6038TM2-5AN (ROHS)
------	----------------	--

TACT SWITCH

S501-509	11-007-0061-90	SW TACT 1P1T 50mA/12V VER H=5mm LUG FUNG (RoHS)
----------	----------------	--

LEDS

D516	12-006-0125-90	LED RED-ORN-BLU CIRCULAR 5X8.7MM BL-BUBJFB52C4V-1 COMMON ANODE (RoHS)
D501-508, D517	12-006-0064-90	LED BLUE DIFFUSED ROUND D3x5.2mm L-7104PBD (RoHS)

CRYSTAL

X501	14-002-0023-90	Crystal 20.000MHz 30ppm 32pF HC-49/S 01-CR1-02-20M000-32-3030 (RoHS)
------	----------------	---

SMD ICS

U503	0130300104820- 900100	Programmed MCU 8 BITS 8K ROM 512 BYTES RAM TQFP ATmega48-20
U501-502	01-012-0065-90	IC Logic 8-Stage Shift-And-Store Bus Register SMD SO16 HEF4094BT <HEF4094BT,653 PHI> (PHILIPS) (RoHS)

SMD RESISTORS

R530 R544 R545	02-007-0034-90	SMD RES 1.5K OHM 0805 5% 2.0X1.25X0.55 (RoHS)
R517-519	02-007-0042-90	SMD RES 1K OHM 0603 5% (RoHS)
R501-516 R540-541	02-007-0139-90	SMD RES 4.7K OHM 0603 5% (RoHS)
R532	02-007-0148-90	SMD RES 10K OHM 0603 5% (RoHS)
R524 R526 R528 R533-536 R542	02-007-0157-90	SMD RES 10K OHM 0603 1% (RoHS)
R523	02-007-0288-90	RES SMD 0 OHM 5% 1/16W 0603 TAPE (RoHS)
R520-522 R527	02-007-0292-90	RES SMD 2.2K OHM 1% 1/16W 0603 TAPE (RoHS)
R539	02-007-0299-90	RES SMD 10M OHM +/-5% 1/16W 0603 TAPE (RoHS)
R525	02-007-0368-90	RES SMD 1.5K OHM 5% 1/16W 0603 TAPE (RoHS)
R543	02-007-0581-90	RES SMD 1K OHM 5% 1W 2512 TAPE (RoHS)

SMD CAPACITORS		
C511-513 C515 C518 C520 C527	03-009-0075-90	CAP CER SMD 0.1uF 50V 20% Y5V 0603 TAPE
C503-510 C523	03-009-0113-90	CAP CER SMD 10nF 50V 10% X7R 0603 TAPE (RoHS)
C517 C522	03-009-0116-90	CAP CER SMD 33pF 50V 10% X7R 0603 (RoHS)
SMD DIODES		
D509-513	04-006-0021-90	SMD DIODE LL4148 SOD80 (VISHAY) (RoHS)
SMD TRANSISTORS		
Q501-508 Q513-515	05-004-0018-90	SMD Transistor MMBT5551LT1G NPN SOT-23 (ON) (RoHS)
Q509-511	05-004-0037-90	TRANSISTOR SS PNP HFE30 250MHz SPT DTA114EKAT146(RoHS)(ROHM)
JUMPERS		
JMP2-3 JMP6-7 JMP10 JMP16 JMP18 JMP22 JMP26-30 JMP33-36 JMP45 JMP47 JMP51 JMP54 JMP57 JMP66 JMP69 JMP72 JMP73	17-016-0077-90	Jumper wire Dia. 0.5mm L=52.0mm (RoHS)
JMP1 JMP4-5 JMP8-9 JMP11-15 JMP17 JMP19-21 JMP23-25 JMP31-32 JMP37-44 JMP46 JMP48-50 JMP52-53 JMP55-56 JMP58-61 JMP64-65 JMP68 JMP70-71 JMP74-92 JMP94-96	17-016-0080-90	Jumper Wire Dia. 0.6mm For L Smaller than 14mm Roll (RoHS)
HEADPHONE BOARD		
PCB ASSEMBLY	50-957-0326-90	C326 HEADPHONE BOARD ASSY
RESISTORS		
R493-494	02-010-0042-90	RES MO 100 OHM 5% 2W AXIAL (RoHS)
CAPACTORS		
C525 C526	03-001-0060-90	CAP CER 0.1uF 50V +/-20% Y5V RAD ST5 (RoHS)
JACKS		
M102	15-002-0029-90	PHONE JACK D6.3 1 PCB MOUNT GOLD (RoHS)
M501	15-002-0039-90	PHONE JACK 3.5mm dia. H=5 CKX-3.5-49 GOLD (RoHS)
SMD CAPACTORS		
C501-502	03-009-0111-90	CAP CER SMD 100pF 50V 10% X7R 0603 TAPE (RoHS)
JUMPERS		
JMP62 JMP93	17-016-0080-90	Jumper Wire Dia. 0.6mm For L Smaller than 14mm Roll (RoHS)
BIAS BOARD		
PCB ASSEMBLY	50-963-0326-90	C326 BIAS BOARD ASSY
TRANSISTORS		
Q160 Q360	05-001-0112-90	TRANSISTOR KSC2690AYSTU NPN 1.2A/160V TO-126 FAIRCHILD (RoHS)

IC BLOCK DIAGRAM

Mainboard

NJM7805FA (U104)

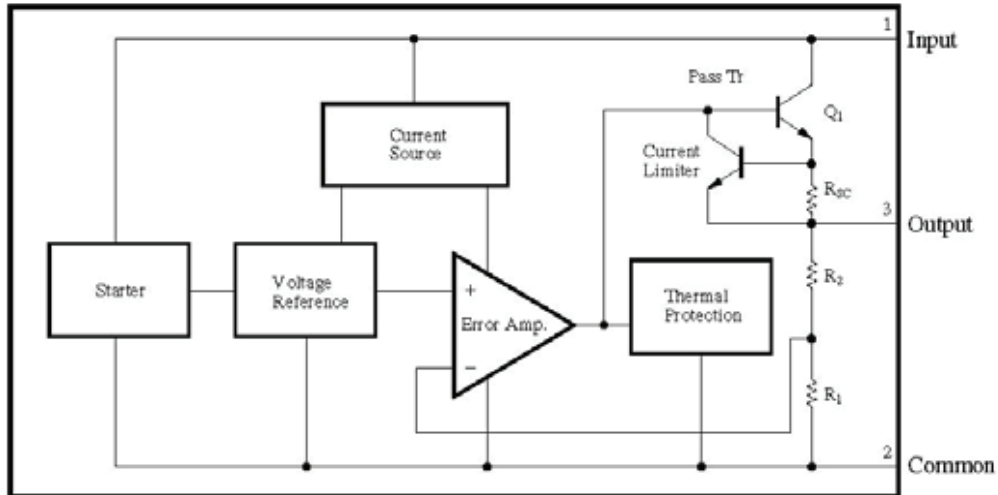

NJM4560M (U101)

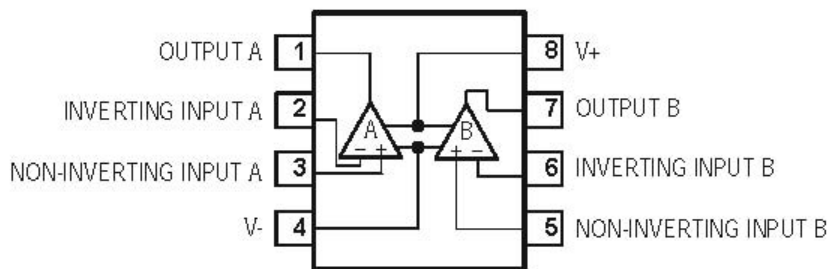

TL431 (U103, U303)

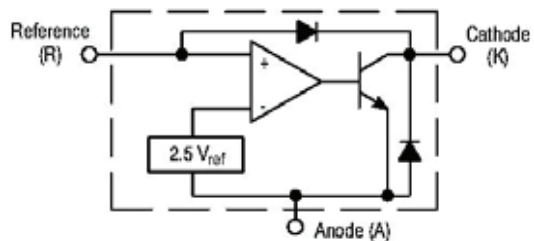

TL071CDR (U102, U301, U302)

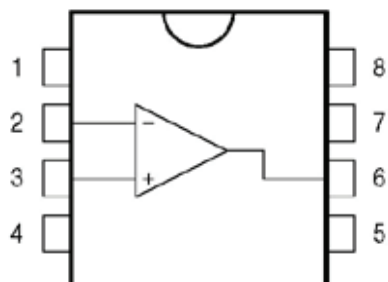

Keyboard

ATMega48-20 (U503)

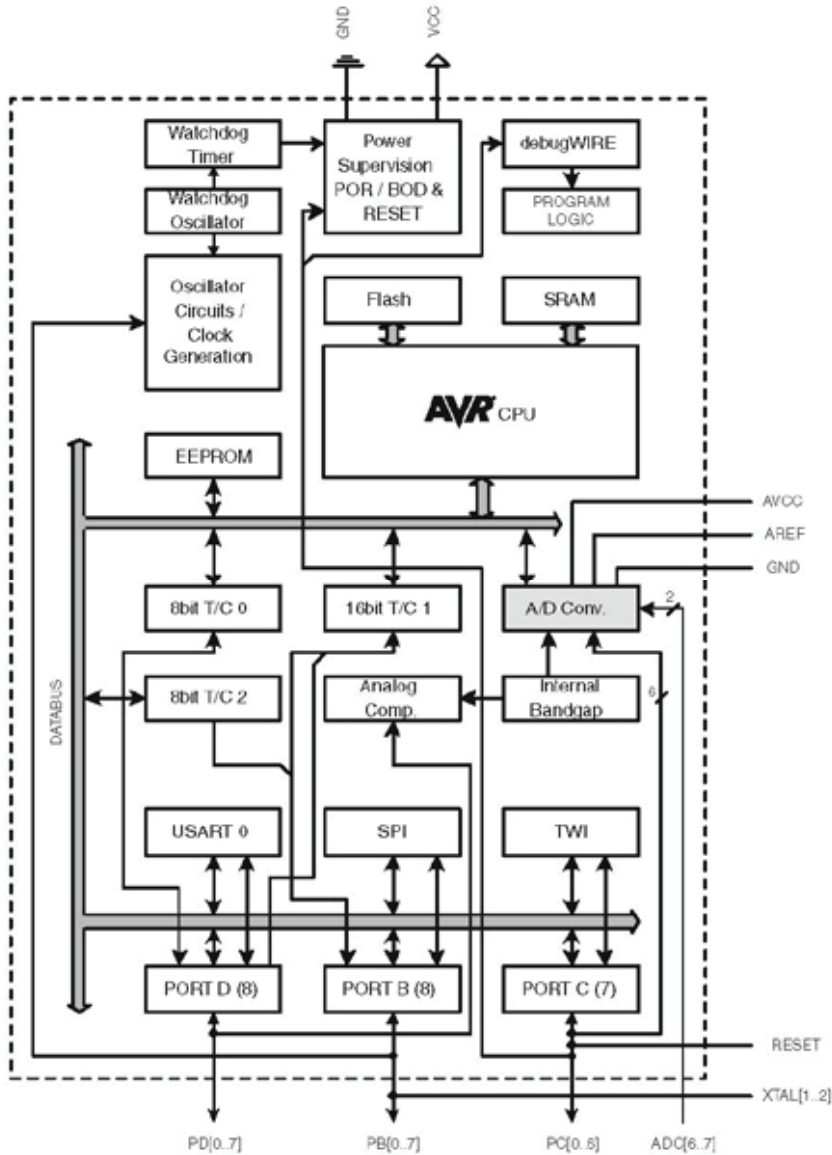

HEF4094BT (U501, U502)

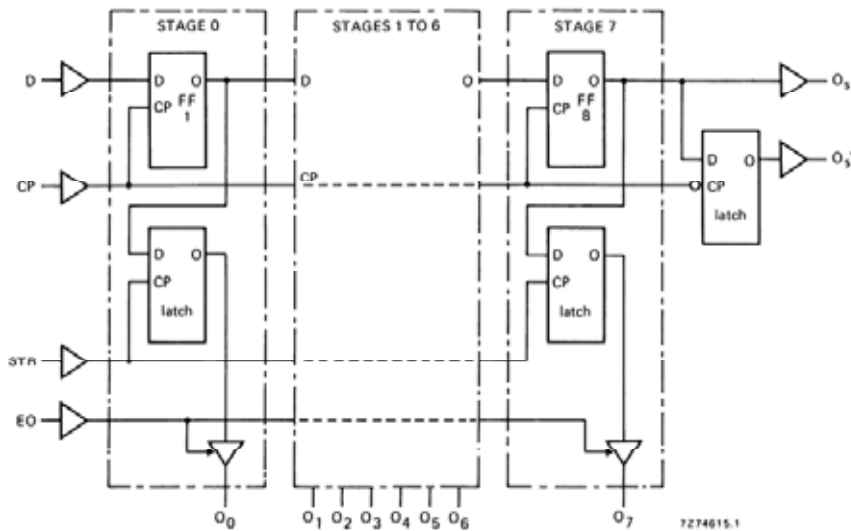

Power Supply

TNY274 (U601)

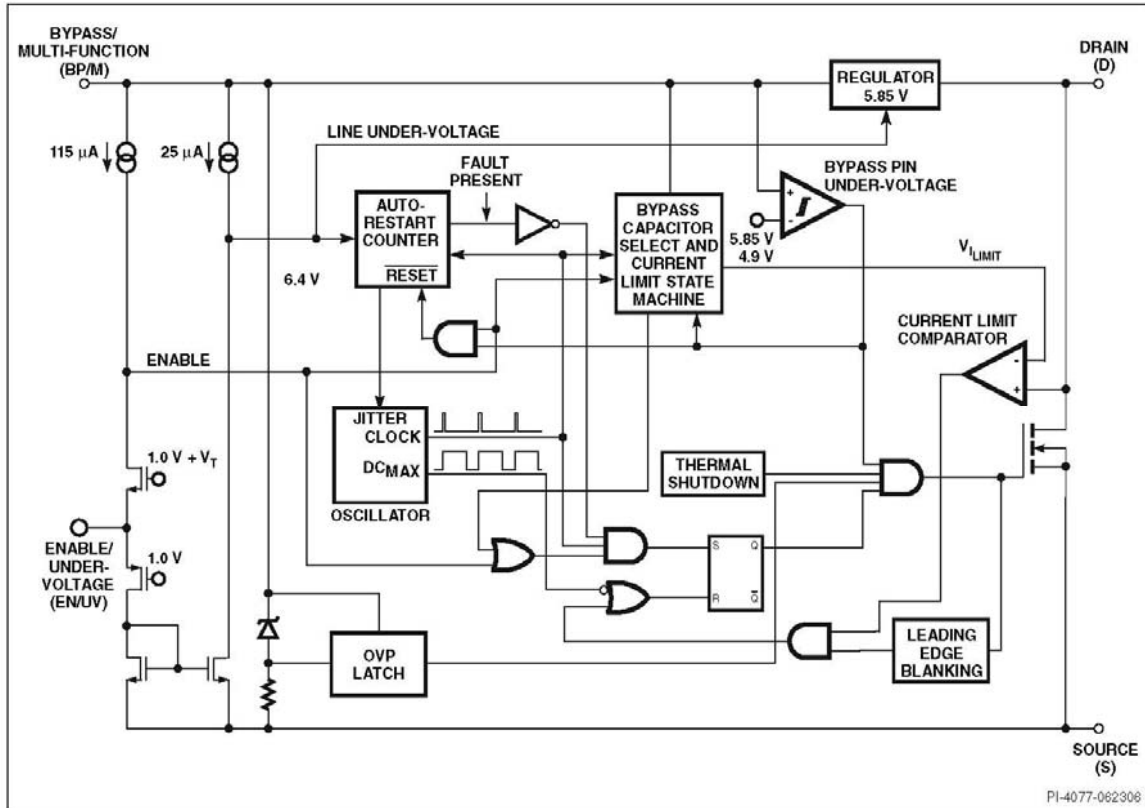

PC817C (U602)

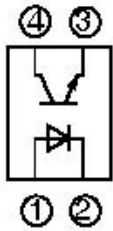

EXPLODED VIEW - A

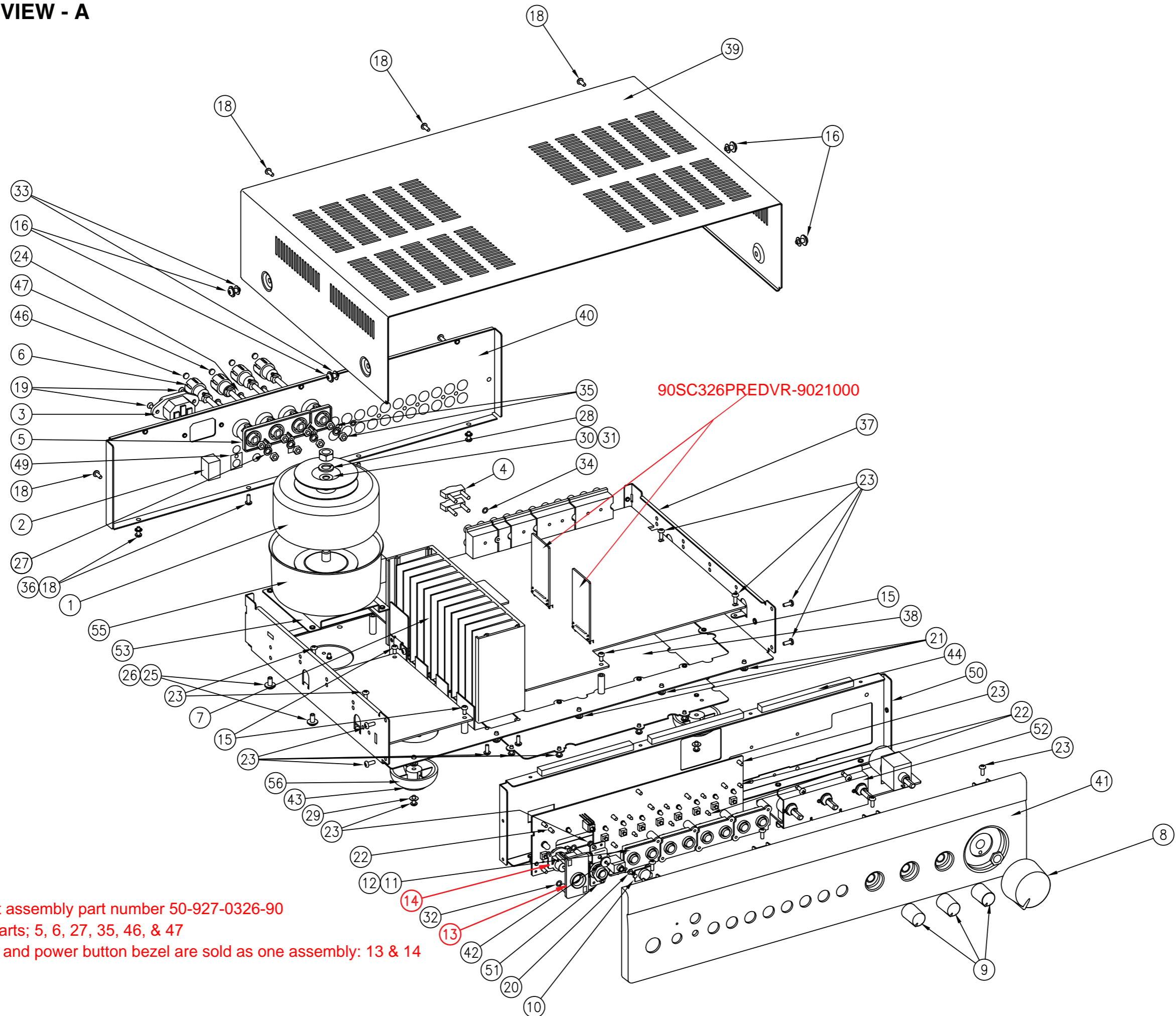

**Note: Terminal post assembly part number 50-927-0326-90

is made up of the parts; 5, 6, 27, 35, 46, & 47

**Note: Power button and power button bezel are sold as one assembly: 13 & 14

EXPLODED VIEW - B NSP HFE SPECIFIC

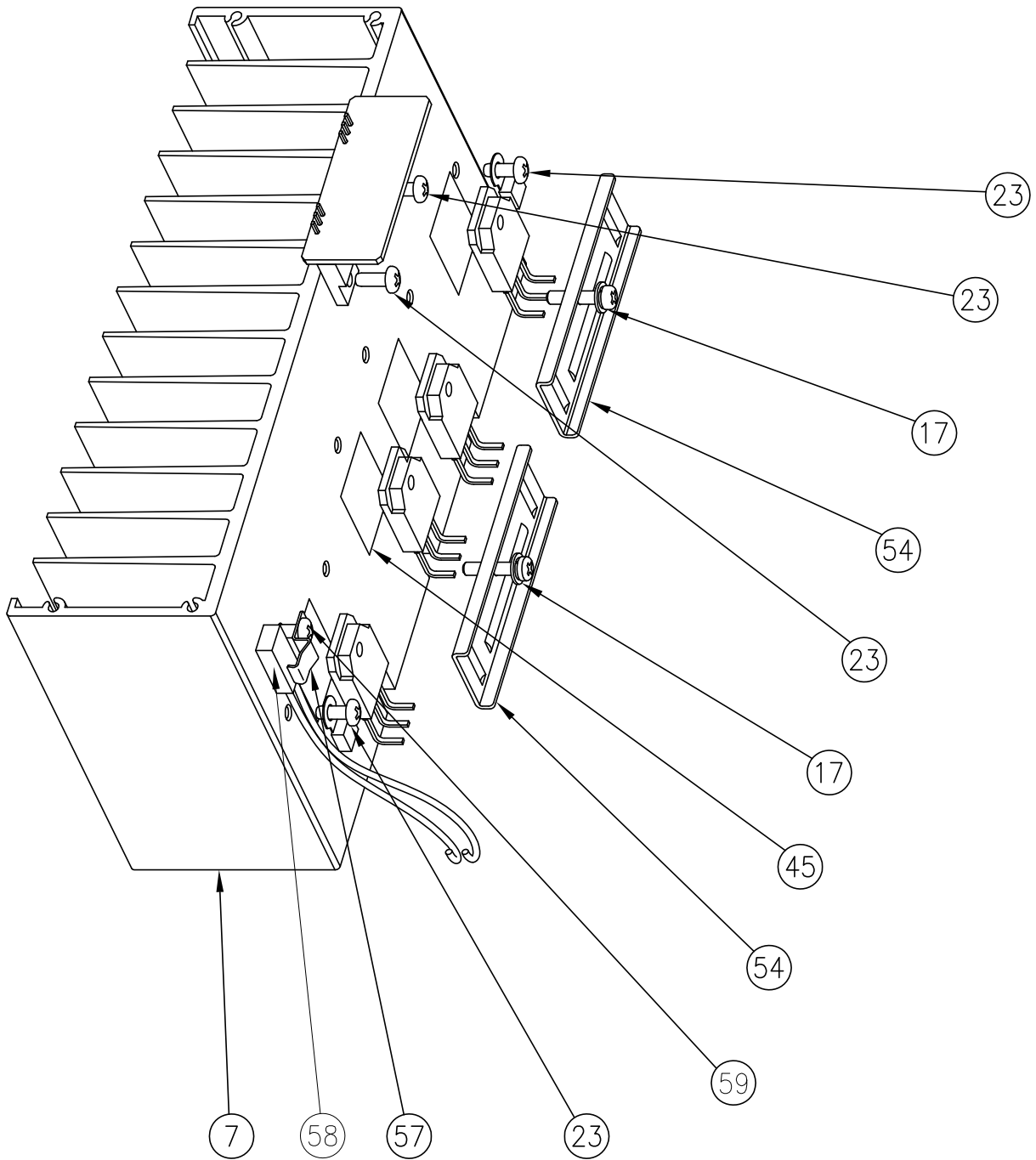

EXPLODED VIEW PARTS LIST

ITEM	PART NO.	DESC.	QTY
1	10-005-0296-90	TRANSFORMER PW TOROIDAL 120V C326 TI-083438 (W/ M6 BOLTx1/ NUTx1/DISHx1/RUBBERx2) (RoHS) [FOR 120V VERSION]	1
	10-005-0297-90	TRANSFORMER PW TOROIDAL 230V C326 TI-083444 (W/ M6 BOLTx1/ NUTx1/DISHx1/RUBBERx2) (RoHS) [FOR 230V VERSION]	1
2	11-001-0062-90	SWITCH ROCKER 1P1T BLK/BLK 10A/250VAC TV-5 UL/CSA/VDE/SEMKO (RoHS)	1
3	15-004-0093-90	AC SOCKET IEC 320 C18 2 PINS 15A/250V UL/CSA 10A/250V VDE SS-7BA-4.8 (RoHS)	1
4	15-017-0005-90	JUMPER PLUG PITCH 14mm SHORTER (RoHS)	2
5	16-001-0439-93	BINDING POST BASE 4P BLACK T765 R.2 (RoHS) NSP	1** NSP
6	16-001-0546-90	SPEAKER TERMINAL 2P W/O BASE CL1596(N) (ROHS)	2** NSP
7	19-001-0170-90	EXT. HEATSINK 51x173 BLACK (RoHS)	1
8	21-002-0195-90	VOLUME KNOB C326BEE GRAPHITE (RoHS) [FOR GRAPHITE VERSION]	1
	21-002-0202-90	VOLUME KNOB C326BEE TITANIUM (RoHS) [FOR TITANIUM VERSION]	1
9	21-002-0196-90	TONE KNOB C326BEE GRAPHITE (RoHS) [FOR GRAPHITE VERSION]	3
	21-002-0203-90	TONE KNOB C326BEE TITANIUM (RoHS) [FOR TITANIUM VERSION]	3
10	21-002-0197-90	IR LENS C326BEE (RoHS)	1
11	21-002-0198-90	2P INPUT BUTTON BEZEL C326BEE GRAPHITE (RoHS) [FOR GRAPHITE VERSION]	4
	21-002-0204-90	2P INPUT BUTTON BEZEL C326BEE TITANIUM (RoHS) [FOR TITANIUM VERSION]	4
12	21-002-0199-90	2P INPUT BUTTON C326BEE GRAPHITE (RoHS) [FOR GRAPHITE VERSION]	4
	21-002-0205-90	2P INPUT BUTTON C326BEE TITANIUM (RoHS) [FOR TITANIUM VERSION]	4
13	21-002-0200-90	POWER BUTTON BEZEL C326BEE GRAPHITE (RoHS) [FOR GRAPHITE VERSION]	1
	21-002-0206-90	POWER BUTTON BEZEL C326BEE TITANIUM (RoHS) [FOR TITANIUM VERSION]	1
14	21-002-0201-90	POWER BUTTON C326BEE GRAPHITE (RoHS) [FOR GRAPHITE VERSION]	1
	21-002-0207-90	POWER BUTTON C326BEE TITANIUM (RoHS) [FOR TITANIUM VERSION]	1
15	22-001-0367-90	SCREW MACHINE M3 x 6 P/H NI PLT (RoHS)	4
16	22-001-0388-90	MACHINE SCREW M4 X 8 WASHER HEAD NI PLT (RoHS)	4
17	22-001-0403-90	MACHINE SCREW M3X14 P/H W/SPRING&PLAIN WASHER CHROME PLT (RoHS)	2
18	22-003-0049-90	SCREW TAPTITE 3x8 B/H TYPE "B" BLK PLT (RoHS)	16
19	22-003-0129-90	SCREW TAPTITE 3x8 SMALL K/H TYPE "B" BLK PLT (RoHS)	2
20	22-003-0138-90	SELF TAPPING SCREW 2X5 WASHER HEAD TYPE B NI PLT (RoHS)	2
21	22-003-0144-90	SCREW TAPTITE 3.5 X 8.0 B/H TYPE B NI PLT (RoHS)	5
22	22-003-0145-90	SELF TAPPING SCREW DIA2.6 X 8 B/H TYPE A NI PLT (RoHS)	10
23	22-003-0165-90	SCREW TAPTITE 3 X 8 B/H TYPE B NI PLT (RoHS)	54
24	22-003-0172-90	SCREW TAPTITE 3 X 10 B/H TYPE B BLK PLT (RoHS)	3
25	22-003-0187-90	SCREW MACHINE M4 X 8 B/H BLACK (RoHS)	4
26	22-005-0034-90	WASHER SPRING I/D 4 x O/D 7 x 1 THK (RoHS)	4

27	22-005-0036-90	WASHER SPRING I/D 5.2 X O/D 8 X 1.2 THK ZINC NSP PLT (RoHS)	4** NSP
28	22-005-0042-90	WASHER SPRING I/D 6.5XO/D10.5X2.0mm THK	1
29	22-006-0081-90	Washer steel I/D 3.5 X O/D 8.0 0.4mm THK.Zinc plt(RoHS)	4
30	22-006-0083-90	WASHER STEEL ID6.5 X OD14 X 0.8 BLK PLT (RoHS)	1
31	22-006-0084-90	STEEL WASHER ID6.5 X 18 X 2.0mm BLACK ZINC (RoHS)	1
32	22-006-0090-90	WASHER PVC ID3.6xOD7.0x0.5mm (RoHS)	2
33	22-006-0091-90	WASHER PVC ID4.2xOD8.2x0.5mm (RoHS)	4
34	22-006-0129-90	WASHER FIBRE ID3.2xOD6x0.5mm THK. W/ NITTO (RoHS)	1
35	22-007-0099-90	NUT #10-32 X 3.2mm NI PLT (RoHS) NSP	8** NSP
36	22-008-0027-90	WASHER EXTERNAL TOOTH M3 ID3.2xOD6.5xTHK NI PLT (RoHS)	2
37	23-232-0029-90	BOTTOM CABINET C326 (RoHS)	1
38	23-236-0025-90	BOTTOM COVER C326 (RoHS)	1
39	23-236-0024-90	TOP COVER C326 (PAINTED PPG GREY) (RoHS) [FOR GRAPHITE VERSION]	1
	23-236-0026-90	TOP COVER C326 (PAINTED SILVER) (RoHS) [FOR TITANIUM VERSION]	1
40	23-237-0069-93	REAR PANEL C326 AH R2 (RoHS) [FOR 120V VERSION]	1
	23-237-0071-93	REAR PANEL CE C326 R2 (RoHS) [FOR 230V VERSION]	1
41	23-237-0070-92	PLASTIC FASCIA C326 GRAPHITE R1 (RoHS) [FOR GRAPHITE VERSION]	1
	23-237-0072-90	PLASTIC FASCIA C326 TITANIUM (RoHS) [FOR TITANIUM VERSION]	1
42	25-008-0409-90	POWER LED LENS - ROUND #2 MILKY WHITE (RoHS)	1
43	25-014-0030-90	RUBBER FOOT I/D14 X O/D26 X 3 PORON HH-48C (RoHS)	4
44	25-016-0033-90	FOAM 100x7x8mm BLACK (UL GRADE) W/ NITTO 500 (RoHS)	3
45	25-020-0342-90	INSULATOR MICA SHEET 1KV L28 X W22 X T0.1 W/O HOLES (RoHS)	4
46	25-020-0428-90	BANANA PLUG BLACK 159778 (CLIFF) NSP	2** NSP
47	25-020-0429-90	BANANA PLUG RED 159777 (CLIFF) NSP	2** NSP
48	25-020-0536-90	FIBRE PAPER 80 X 40 X 0.5mm THK. UL GRADE (RoHS)	1
49	25-020-0558-90	INSULATOR 14x17x0.3mm PVC BLACK (RoHS)	1
50	25-022-1703-92	SUBFASCIA C326 R1 (RoHS)	1
51	25-022-1704-90	PHONE BRACKET C326 (RoHS)	1
52	25-022-1705-90	TONE CONTROL BRACKET C326 (RoHS)	1
53	25-022-1706-90	TRANSFORMER BRACKET C326 (RoHS)	1
54	25-022-1725-90	POWER TRANSISTOR CLAMPER 2X 20 x 60mm (RoHS)	2
55	25-022-1746-90	TRANSFORMER SHIELD CAN C326 (RoHS)	1
56	25-024-0315-90	PLASTIC FOOT DOME SHAPE (RoHS)	4
57	25-022-1243-90	CLIP THERMAL SWITCH (RoHS)	1
58 *AH	20-004-0043-90	THERMAL CUT OFF SWITCH 90C ST-22 (RoHS)	1
59 *AH	22-003-0149-90	TAPTITE SCREW 3X6MM PAN HEAD TYPE "B" NI PLT (RoHS)	1

**Note: Terminal post assembly part number 50-927-0326-90 is made up of the parts; 5, 6, 27, 35, 46, & 47

PACKING DIAGRAM & PARTS LIST

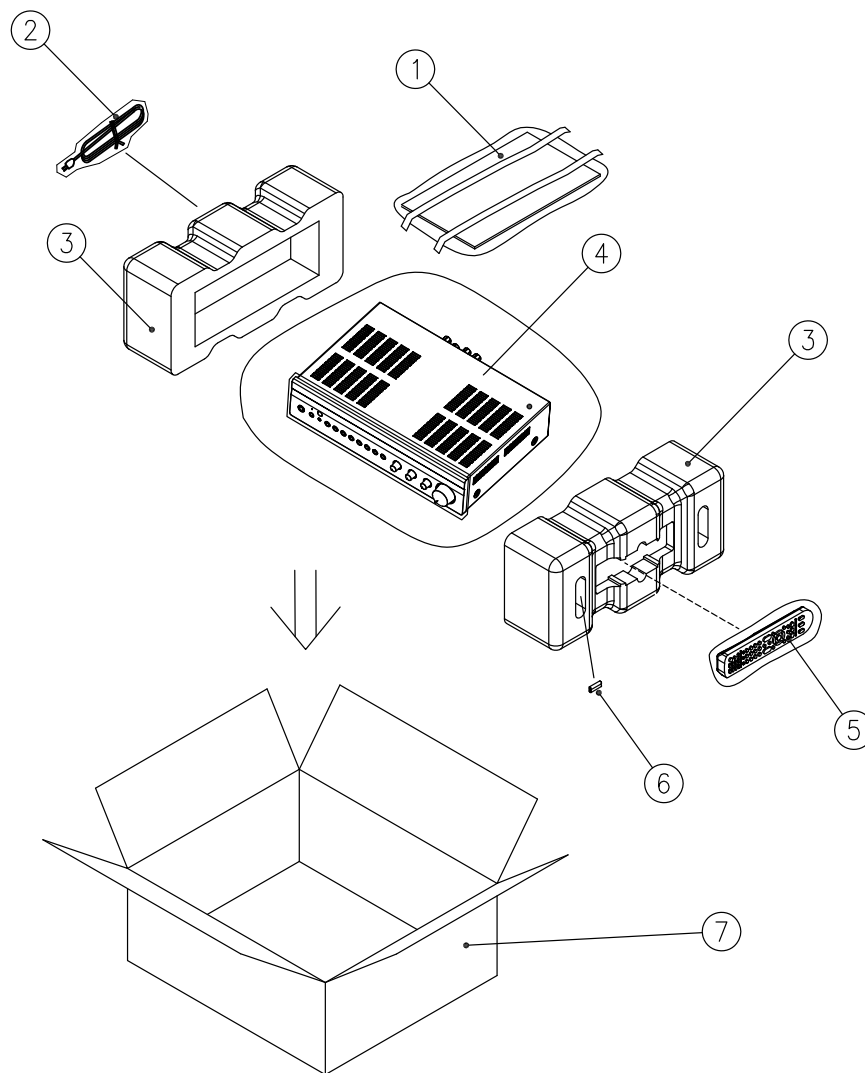

ITEM	PART NO.	DESCRIPTION	QTY
1	24-003-0127-90	POLYBAG MAUNAL (RoHS)	1
1	24-004-1936-92	CARD WARRANTY NAD MODELS R.1 (RoHS)	1
1	24-004-2385-92	C326BEE OWNER'S MANUAL R.1 (RoHS)	1
2	24-003-0119-90	POLYBAG CORD (RoHS)	1
2	17-004-0026-90	AC Cord 110V 2 PINS 125V/13A SJT AWG18/3C UL/CSA L=2M (RoHS) [FOR AH VERSION]	1
	17-004-0027-90	AC CORD CE 2 PINS 16A 250V LF L=2M H05VV-F 2G 0.75 BLACK (RoHS) [FOR C, CT VERSION]	1
3	24-006-0992-90	POLYFOAM ENDCAP C326BEE (RoHS)	2
4	24-003-0119-90	POLYBAG MAIN UNIT (RoHS)	1
4	24-003-0166-90	PROTECTIVE COVER (RoHS)	1
4	40-001-0108-90	DESSICANT BAG 20g	1
5	28-008-0010-90	REMOTE CONTROLLER NAD SR 8 (RoHS)	1
6	25-007-0024-90	BATTERY AA 1.5V R6P AA (RoHS)	2
7	24-001-0729-90	MASTER CARTON BOX C326BEE (RoHS)	1