

SERVICE MANUAL



C 390DD

Direct Digital Powered DAC/Amplifier

C 390DD

Direct Digital Powered DAC/Amplifier



C 390DD Direct Digital Powered DAC/Amplifier



Our C 390DD DAC/Amplifier is a new concept in amplification and in high definition audio system architecture. Featuring Direct Digital technology first introduced in our now famous M2 Direct Digital Amplifier, the C 390DD will amaze with its transparent, dynamic and detailed sound quality. The most accurate DAC/amplifier ever devised, the C 390DD is packed with loads of power, MDC upgradability, software defined operation (offering simple software updates), and exclusive NAD features. Rethink how a music system should look and sound.

FDP 2 x 150W
Full Discontinuous Power

DPD
Digital PowerDrive

MDC Modular Design Construction

<0.5W
STANDBY

Features

> Revolutionary Direct Digital Technology

The C 390DD's proprietary Direct Digital technology has no analogue stages in the signal path, keeping music in the digital domain right up to the speaker outputs. Preamp functions occur in the digital domain without the phase shift, noise, and distortion that plagues all analogue designs. A 35-bit architecture and a 108MHz master clock also make Direct Digital one of the most accurate DAC technologies available. Direct Digital also includes a large amount of DSP processing power, which we have fully exploited to give you extra useful features.

> Immense Power

The C 390DD has a very high continuous power rating of 150W per channel with almost immeasurable distortion and noise. Our exclusive Digital PowerDrive circuit senses the speaker load and alters amplifier characteristics to enhance power delivery into your loudspeakers with great efficiency. Digital PowerDrive can more than triple the C 390DD's rated power while effortlessly reproducing musical transients with accuracy.

> New System Architecture

The C 390DD performs the functions of multiple conventional components, so you can change the way your music system is configured. The C 390DD is ready for the world of computer audio with its asynchronous USB input that can directly play 24/96 content from your computer. Connections in front and rear support USB portable flash memory devices and external hard drives (FAT32).

> Modular Design Construction (MDC)

A pure digital system has many advantages, but one drawback is the constantly changing delivery formats for digital content. For this reason, we developed MDC, which places all digital interface circuitry on replaceable modules. The C 390DD comes standard with one DD USB-1 Module for USB interface, with room for two more modules. Current options are the DD HDMI-1 Module (three HDMI inputs, one output), and the DD AP-1 Module with phono preamp for analogue source compatibility with the C 390DD's pure digital circuitry.

> Exclusive Room EQ

Room EQ is our simple solution to problematic 'room modes' or 'standing waves' that result in undesirable 'boomy' bass. Playing back a supplied test tone sequence easily tames this problem by using your ears and the C 390DD Room EQ filters. Six frequency centres in the low bass region can be cut (or slightly boosted) to remove the 'boom' without reducing the low bass response.

> Advanced Integration

The C 390DD comes standard with eight inputs, which can be expanded to 14 with the optional MDC modules. Inputs can be activated or hidden, and can be renamed for the source component attached. Listening Mode, Polarity, and NAD Soft Clipping are all easily selected and adjusted. RS-232, IR Inputs/Outputs and 12V triggers all make integration with home automations systems simple and effective.

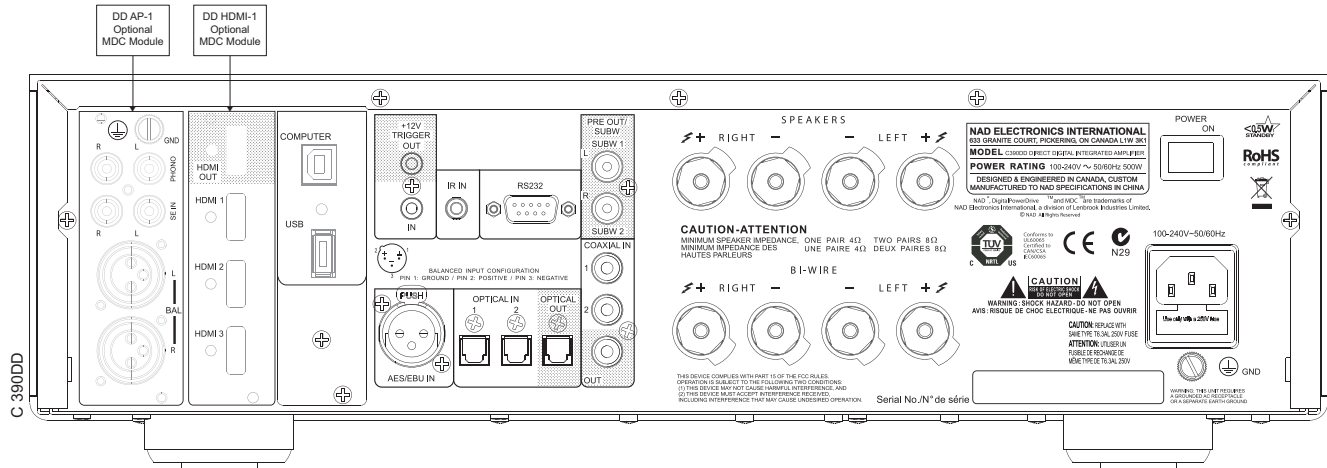

Total Width 435mm

Total Depth 388mm

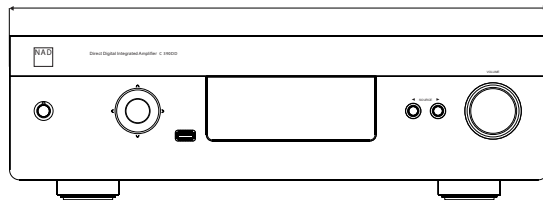

Total Height 132mm

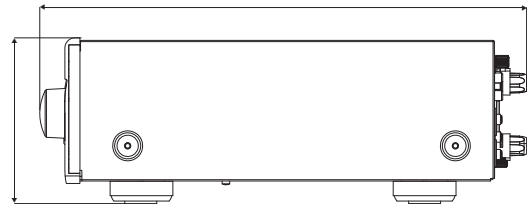

Specifications

DIGITAL INPUT (COAXIAL, OPTICAL)		C 390DD
Input Impedance		75 ohms (coaxial) 110 ohms (AES/EBU)
Sample Rate		32kHz to 192kHz
Frequency Response		±0.5dB (ref. 20Hz-96kHz @ 192kHz)
Channel Separation		>90dB (ref. 10kHz, 4 ohm, 1/3 rated power)
OVERALL SPECIFICATIONS		
Continuous Output Power (ref. 20Hz - 20kHz, rated THD)	8 ohm 4 ohm	≥150W ≥150W
Rated Distortion (THD, with AES17 and AP passive 20kHz LP filters)		<0.005% (ref. 20Hz - 20kHz, 500mW - rated power)
Clipping Power		>165W (ref. 1kHz, 8 ohm, 0.1% THD)
IHF Dynamic Power	8 ohm 4 ohm	160W 350W
Maximum Output Current		>18A
Signal / Noise Ratio		>95dB (A-weighted, ref. 1W) >124dB (A-weighted, ref. 250W)
Damping Factor		>800 (ref. 20Hz - 200Hz)
GENERAL		
Idle Power		40W
Standby Power		<0.5W
Unit Dimensions (WxHxD) - Gross*		435 x 132 x 388mm 17 1/8 x 5 1/4 x 15 5/16 inches**
Net Weight		7.7kg (16.94lb)
Shipping Weight		9.78kg (21.5lb)

* Gross dimensions include feet, extended buttons and rear panel terminals.

** Non-metric measurements are approximate. NAD Electronics will not assume any liability for errors being made by retailers, custom installers, cabinet makers, or other end users based on information contained in this document.

Note: Installers should allow a minimum clearance of 55mm for wire/cable management.

NAD

NAD Electronics International reserves the right to change specifications or features without notice. NAD is a registered trademark of NAD Electronics International. All rights reserved. No part of this publication may be reproduced, stored, or transmitted in any form whatsoever without the written permission of NAD Electronics International. © 05/12 11-040 NAD Electronics International.

www.NADelectronics.com

SPECIAL FUNCTION

Function	Keys	Notes
Factory Reset	Source Down +Source UP	
Check MCU Version	Enter(press 3second)	
Check DSP Version	Enter (press 3second)	
VFD Test	Source Down + Right	
Enter into Bootloader	Standby+Switch on	
Check USB Card Version	Enter(press 3second)	
Change Input source name	Source Down(press 3second)	

DETAILS & WAVEFORMS ON SYSTEM TEST & DEBUGGING

Main Board Y1000 8MHz

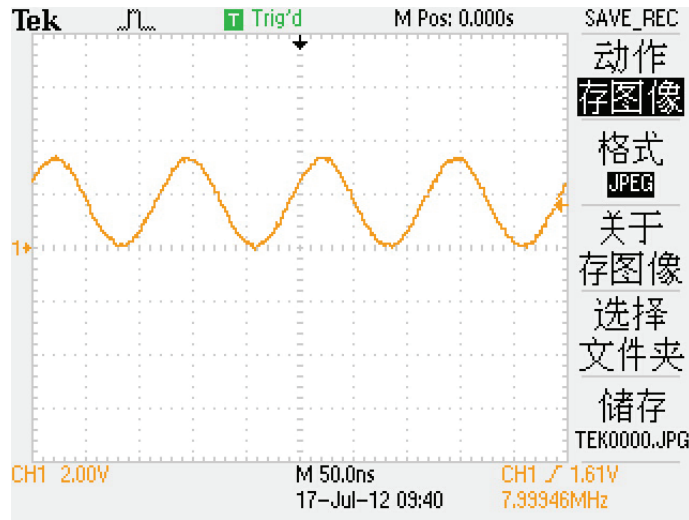

USB Board

XC7000 11.2896MHz

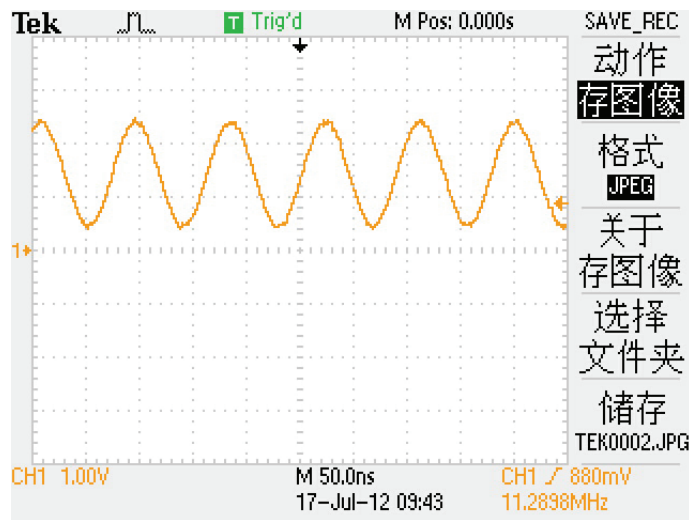

LRCK 96K

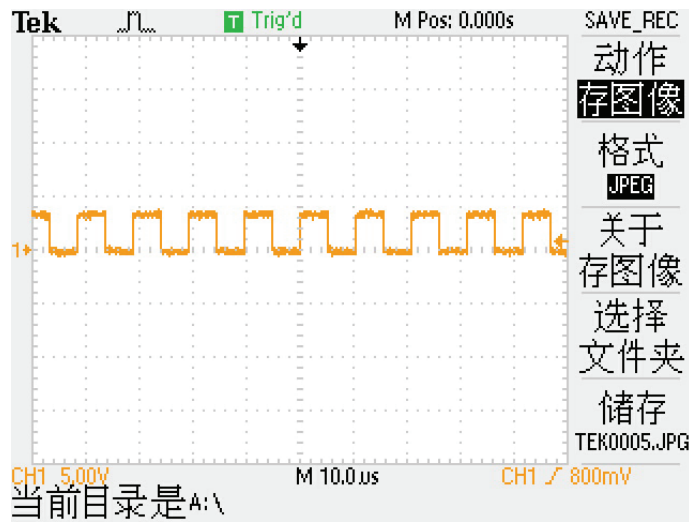

BCK

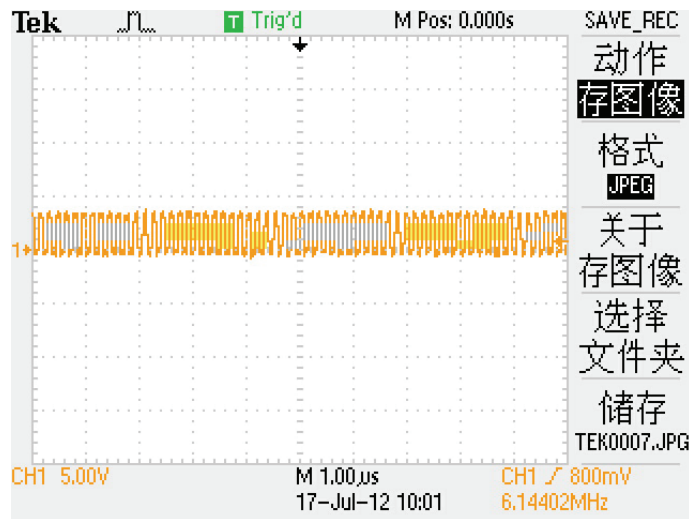

LRCK 192KHz

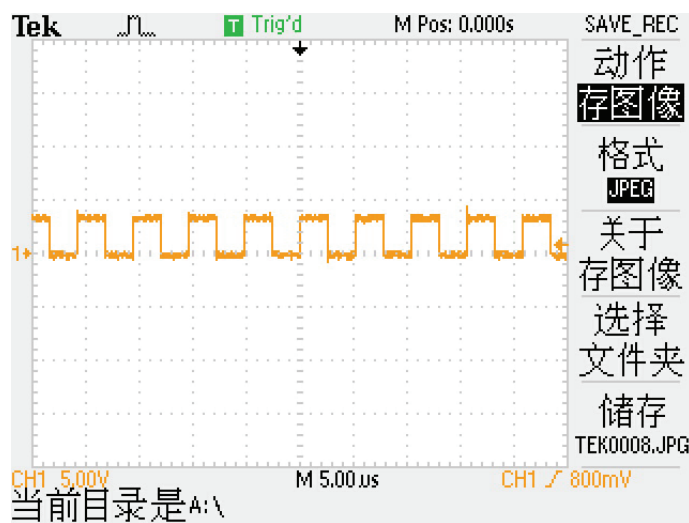

BCK 12.288MHz

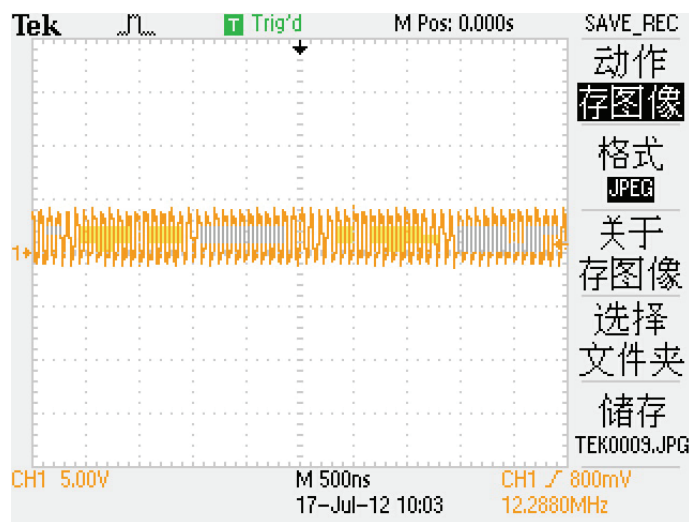

AMP Board X1 108MHz

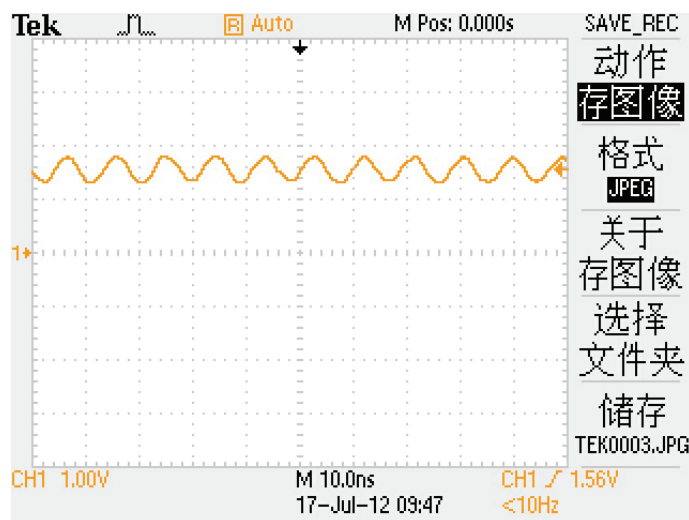

Q301 (G) 844kHz

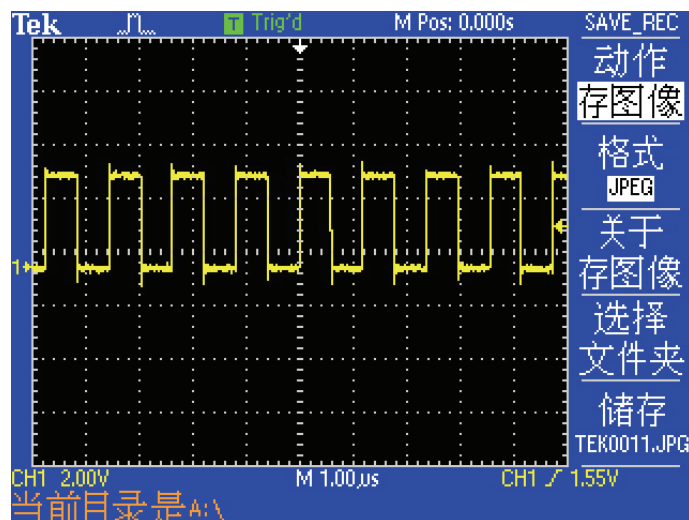

wiring diagram

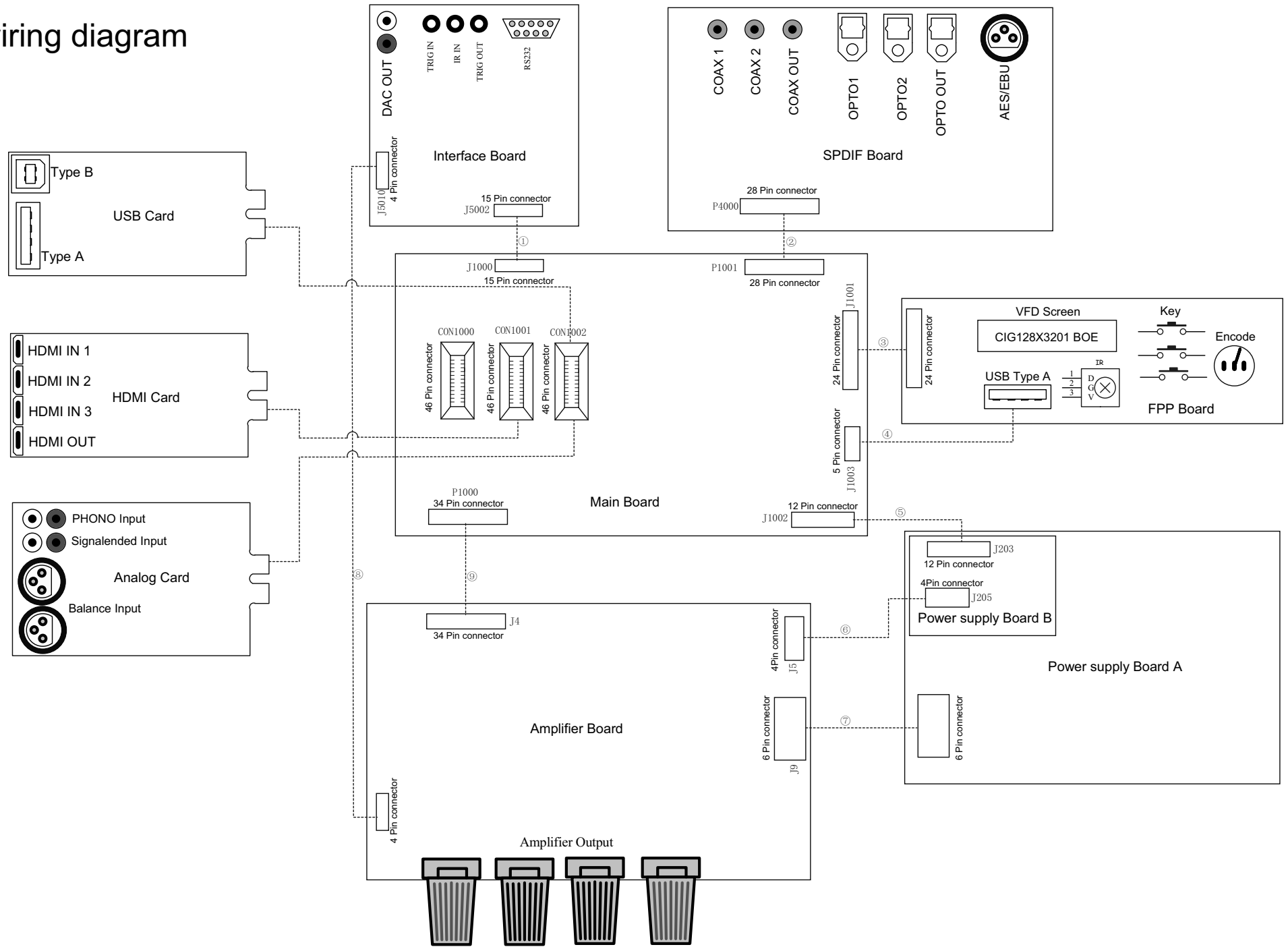

WIRING DIAGRAM PARTS LIST

Item	Database Part Number	Description Remark	Remark
1	14-50215-00	15PIN, 1.0mm spacing, L=100mm 0.1X0.65	Main Board J1000/Interface Board J5002
2	14-39028-00	28PIN, 1.0mm spacing, L=90mm 0.1X0.65	Main Board P1001/Spdif Board P4000
3	14-39024-10	24PIN, 2.0mm spacing, L=250mm, CNT-C200-24-250	Main Board J1001
4	14-39005-10	5PIN, UL2547#24AWG*3C/UL1007#24AWG (red), JC3B-5Y, JC25-5Y, L=430mm	Main Board J1003
5	14-39012-00	12PIN, UL1569#22AWG, TJC3B-12Y, L=330mm	Main Board J1000/Interface Board J5002
6	14-39004-01	4PIN, UL1007#24AWG, red/black, TJC3B-4Y, L=220mm	Amplifier Board J5/Power Supply Board B J205
7	14-39006-00	6PIN, UL1569#18AWG, Red/Black/Blue, VH-6Y, SDN-6Y, L=250mm	Amplifier Board J9/Power Supply Board A J101
8	14-39004-00	4PIN, UL1691#24AWG, TJC3B-4Y, 2 SAN-2Y, L=330mm	Amplifier Board J6, J7/Interface Board J5010
9	14-39034-00	34PIN, 2.0mm spacing, L=150mm, CNT-C200-34-1500mm	Amplifier Board P1000/IMain Board J4

Block Diagram

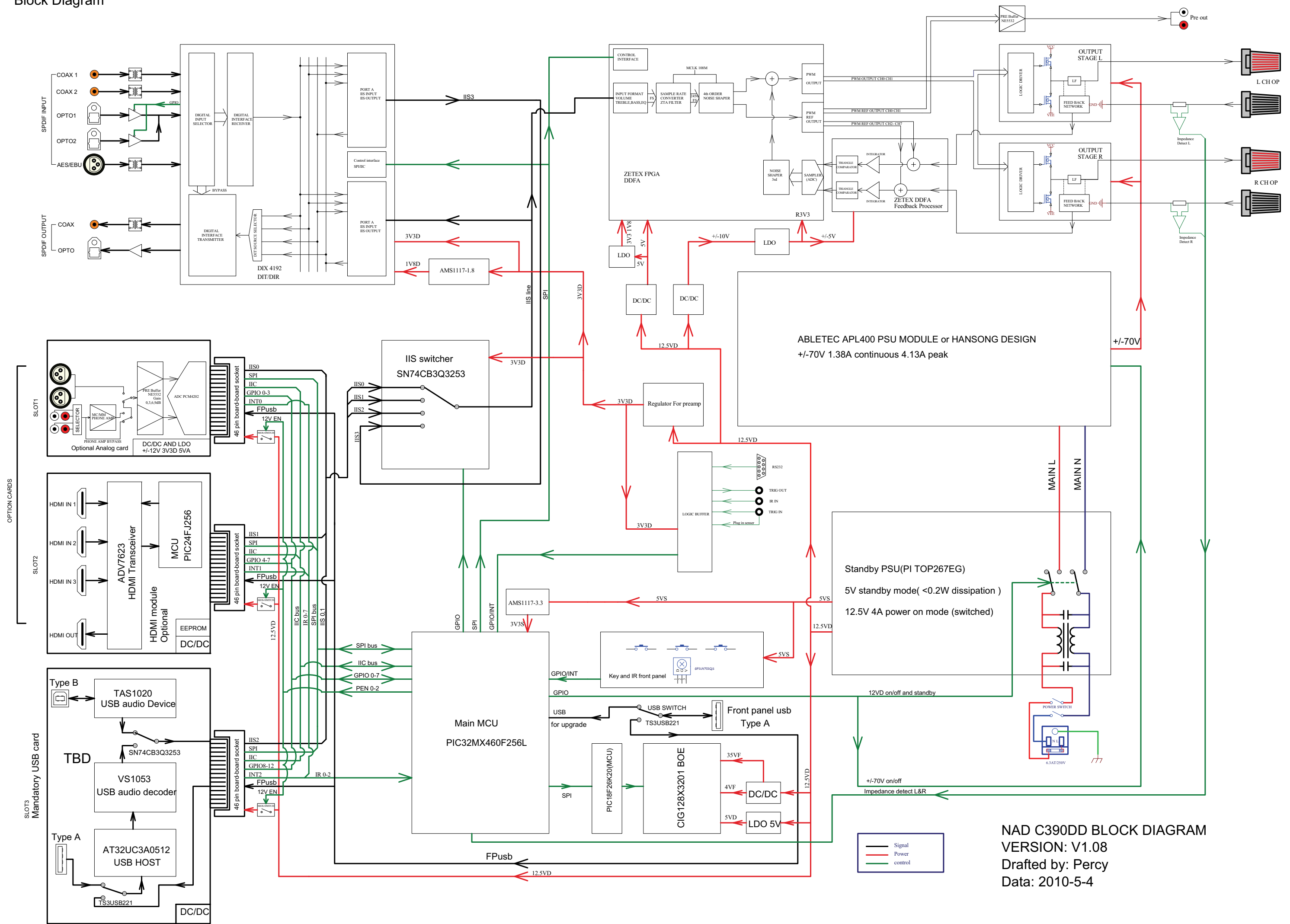

NAD C390DD BLOCK DIAGRAM
 VERSION: V1.08
 Drafted by: Percy
 Data: 2010-5-4

ELECTRICAL PARTS LIST

C390DD BOM

<i>IC</i>			
03-02985-33	Regulator	LP2985-33DBVR	U6023
03-01117-01	Linear Regulator	LM1117MPX-5.0/NOBP/ AMS1117-5.0	U6000
03-05532-03	Dual OPAMP	NE5532DR SOIC8	U6004, U6007, U6008, U6009
03-01804-01	A/D Converter	PCM1804DBR	U6005
03-02134-00	Dual OPAMP	OPA2134UA/2K5E4 SO-8	U6010
03-02611-01	Power converter	LM2611BMF,SOT23-5	U6013
03-00595-01	Shift Register	SN74HC595D/74HC595D/MM74HC595M	U6015
03-00138-05	3 TO 8 LINE DECODER	74HC138D	U6016
or 03-00138-02	Line Decoder	MM74HC138M	U6016
03-00084-02	Quad OPAMP	TL084BCD	U6017
03-01195-01	Audio Attenuator	NJW1195V	U6006
03-00244-01	Octal Buffer	74LCX244	U6014
03-00714-01	UHS Dual Inverter with Schmitt Trigger Inputs	NC7WZ14P6X	U6018, U6019
03-74901-01	Regulator	TPS7A4901DGNR	U6021
03-73001-01	Regulator	TPS7A3001DGNR	U6022
<i>Diode</i>			
33-20004-01	Zener Diode	S1GM4 SMA	D6000
33-40054-00	Schottky Diode	BAT54S, SOT23	D6001, D6002, D6003, D6004
33-40352-01	Switch Diode	1SS352(TPH3,F),1SS355TE-17	D6005, D6006, D6014, D6015, D6018, D6019, D6020, D6021, D6022
33-44148-17	Switch Diode	1N4148W-NR	D6007, D6013
33-30560-01	DIODE SCHOTTKY	MBR0560-TP	D6009
<i>Transistor</i>			
31-01815-03	Transistor	C1815, SOT23	Q6026, Q6126
31-01015-03	Transistor	A1015, SOT23	Q6025, Q6125
31-00114-05	Digital transistor	DTC114EKA	Q6017
<i>Inductor</i>			
08-04100-08	Power Inductor	10uH,MSS7341-103ML	L6030
08-04331-06	Ferrite Bead SMD	742792037, 330ohm@100MHz, ±25%, 2A	L6000, L6005, L6006, L6016, L6026
08-04301-04	Ferrite Bead SMD	742792035, 300ohm@100MHz, ±25%, 0.3A	L6100
<i>Capacitor</i>			
26-10051-00	Ceramic Chip Capacitor	10pJ,50V,0603,NPO	C6125
26-33151-00	Ceramic Chip Capacitor	330pJ,50V,0603,NPO	C6104
26-47351-00	Ceramic Chip Capacitor	47nK,50V,0603,X7R	C6123, C6124
26-10421-10	Cermatic Chip Capacitor	100nK,25V 0603,X7R	C6000, C6029, C6030, C6034, C6041,C6102, C6111, C6129, C6130, C6183
26-33051-01	Ceramic Chip Capacitor	33PJ,50V,0805,NPO	C6064, C6131, C6122, C6054
26-10151-01	Ceramic Chip Capacitor	100pJ,50V,0805,NPO	C6016, C6027, C6039, C6050, C6300, C6301, C6100, C6107, C6108, C6109
26-18151-01	Ceramic Chip Capacitor	180pJ,50V,0805,NPO	C6028, C6047
26-56151-01	Multilayer Ceramic CAP	560pJ,50V,0805,NPO	C6019, C6037, C6043, C6053
26-10212-01	ceramic capacitor	1nJ,100V,0805,NPO	C6192, C6193,
26-15251-11	Ceramic Chip Capacitor	1n5J,50V,0805,NPO	C6024, C6049
26-10351-01	Cermatic Chip Capacito	10nK,50V,0805,X7R	C6191, C6194, C6195, C6196
26-10421-01	Ceramic Chip Capacitor	100nK,25V,0805,X7R	C6008, C6025, C6032, C6042, C6199, C6200, C6204, C6205, C6206,C6068, C6069, C6070, C6071, C6072, C6081, C6082, C6083, C6084, C6085, C6116, C6117, C6182
26-22451-11	Cermatic Chip Capacito	220nK,50V,0805,X7R C2012X7R1H224KT	C6089, C6090
26-22511-01	Ceramic Chip Capacitor	2u2F,16V 0805, X7R	C6088,C6087, C6091,C6092
26-47521-11	Ceramic Chip Capacitor	4.7uK,25V,X5R,0805,C2012X5R1E475KTJ00E	C6197, C6198
26-10611-11	Ceramic Chip Capacitor	10uFK,10V,X5R,0805,C2012X5R1A106KT	C6002, C6006
26-22660-11	Ceramic Chip Capacitor	22uF, 6.3V, X5R, 0805	C6005, C6026
26-10521-22	Ceramic Chip Capacitor	1uF, 10%, 25V,X7R,1206	C6101
26-10621-12	Ceramic Capacitor SMD	10uF, 25V, X5R, 1206, C3216X5R1E106KT	C6009
26-10621-12	Ceramic Chip Capacitor	10uF, 25V, X5R, 1206, C3216X5R1E106KT	C6004, C6086, C6093, C6095, C6096, C6106, C6207, C6208

C390DD BOM

07-94701-00	Chip Resistor	4.7KΩ,0603,1/10W,±1%,RC0603FR-074K7L	R6031
07-91000-00	Chip Resistor	100Ω,0603,1/10W,±1%,RC0603FR-07100RL	R6116, R6117, R6119, R6120
07-93301-00	Chip resistor	3.3KΩ,0603,1/10W,±1%,RC0603FR-073K3L	R6135
07-92211-00	Chip Resistor	2.21KΩ,0603,1/10W,±1%,RC0603FR-072K21L	R6136, R6137, R6138, R6139
07-91002-00	Chip Resistor	10KΩ,0603,1/10W,±1%,RC0603FR-0710KL	R6146, R6154, R6155, R6156, R6158, R6160, R6232, R6233
07-91022-00	Chip Resistor	10.2KΩ,0603,1/10W,±1%,RC0603FR-0710K2L	R6121
07-92202-00	Chip resistor	22KΩ,0603,1/10W,±1%,RC0603FR-0722KL	R6144, R6145, R6153
07-99312-00	Chip Resistor Network	93.1kΩ,0603,1/10W,±5%	R6118
07-91003-00	Chip Resistor	100KΩ,0603,1/10W,±1%,RC0603FR-07100KL	R6147, R6151, R6152
07-91803-00	Chip Resistor	180KΩ,0603,1/10W,±1%,RC0603FR-07180KL	R6140, R6141
07-92203-00	Chip resistor	220KΩ,0603,1/10W,±1%,RC0603FR-07220KL	R6148
07-95103-00	Chip Resistor	510KΩ,0603,1/10W,±1%,RC0603FR-07510KL	R6142, R6143
07-96343-00	Chip Resistor	634KΩ,0603,1/10W,±1%,RC0603FR-07634KL	R6150
07-90475-00	Chip Resistor	4.7MΩ,0603,1/10W,±5%,RC0603JR-074M7L	R6149
07-90000-01	Chip resistor	0Ω,0805,1/8W,±5%	R6007, R6010, R6080, R6081, R6229
07-91000-01	Chip Resistor	100Ω,0805,1/8W,±1%,RC0805FR-07100RL	R6022, R6042, R6051, R6065, R6085, R6161
07-92430-01	Chip Resistor	243Ω,0805,1/8W,±1%,RC0805FR-07243RL	R6002
07-93320-01	Chip Resistor	332Ω,0805,1/8W,±1%,RC0805FR-07332RL	R6021, R6067
07-94750-01	Chip resistor	475Ω,0805,1/8W,±1%,RC0805FR-07475RL	R6105, R6108
07-91051-01	Chip Resistor	1.05KΩ,0805,1/8W,±1%,RC0805FR-071K05L	R6004
07-91211-01	Chip resistor	1K21Ω,1/8W,±1%,0805	R6106, R6107
07-94641-02	Chip Resistor	4.64KΩ,1206,1/4W,±1% RC1206FR-074K64L	R6018, R6043, R6052, R6068
07-91002-01	Chip Resistor	10KΩ,0805,1/8W,±1%,RC0805FR-0710KL	R6115
07-91152-01	Chip resistor	11.5KΩ,0805,1/8W,±1%,RC0805FR-0711K5L	R6234, R6237
07-95602-01	Chip Resistor	56KΩ,0805,1/8W,±1%,RC0805FR-0756KL	R6038, R6059
07-95622-01	Chip Resistor	56.2KΩ,0805,1/8W,±1%,RC0805FR-0756K2L	R6015, R6032, R6049, R6060, R6075, R6083, R6096, R6098
07-91023-01	Chip resistor	102KΩ,0805,1/8W,±1%,RC0805FR-07102KL	R6235, R6236
07-91004-01	Chip resistor	1MΩ,0805,1/8W,±1%,RC0805FR-071ML	R6076, R6084, R6097, R6099
07-90338-02	Chip resistor	0.33Ω,1206,1/4W,±5%,RL1206JR-07R33L	R6230, R6231
07-90439-02	Chip resistor	4.3Ω,1206,1/4W,±5%,RC1206JR-074R3L	R6000
07-91009-02	Chip Resistor	10Ω,1206,1/4W,±1%,RC1206FR-0710RL	R6330
07-92200-02	Chip Resistor	220Ω,1206,1/4W,±1%,RC1206FR-07220RL	R6028, R6040, R6056, R6062
07-91211-02	Chip resistor	1.21KΩ,1206,1/4W,±1%,RC1206FR-071K21L	R6019, R6047, R6053, R6071
07-92211-02	Chip Resistor	2.21KΩ,1206,1/4W,±1%,RC1206FR-072K21L	R6027, R6033, R6039, R6054, R6058, R6055
07-90820-10	Chip Resistor NET	82Ω,0603X4,±5%,YC164-JR-0782RL	R6061
07-90121-10	Chip Resistor Network	120Ω,0603x4,1/10W,±1%	R6122, R6123, R6129, R6134, R6159
07-90103-10	Chip Resistor Network	10KΩx4,±5% 0603x4	R6124
		IC	
03-00317-00	3-Terminal Adjustable Regulator	LM317T	U6002
		Inductor	
08-05201-00	Common Mode Choke	T9*5*3-200uH	L6003
		Relay	
12-02202-15	Signal Relay	HFD31/5 5VDC	RL6001
		Connector	
17-01004-23	4POL RCA	AV4-8.4-13/PB1,上红下白,右下脚加接地片,镀厚金	J6000
J17-09003-28	Mic Connector	NC3FAAH2	J6001, J6002
13-22516-06	Connector	CNT-F254-2*8-GS-850-N, 2.54间距, 2x8Pin	P1002
13-22510-09	Connector	CNT-F254-2*5-GS-850-N, 2.54间距, 2x5Pin	P1004
		Capacitor	
06-22011-18	Alu Electrolytic Capacitor	22uF,16V,±20%,85°C,ECEA1CKS220(i)	C6044, C6046, C6094, C6099, C6075, C6080, C6119, C6120, C6048
06-10121-04	Alu Electrolytic Capacitor	CD263(X),100uF,25V,±20%,105°C,F2.5	C6007, C6076, C6078, C6097, C6098, C6127
06-10111-36	Alu Electrolytic Capacitor	HCN 100uF,16V,±20%,105°C,F2.5	C6105, C6190
06-22160-07	Alu Electrolytic Capacitor	HCN,220uF,6.3V,±20%,105°C,F2.5	C6010
06-22160-04	Alu Electrolytic Capacitor	CD281L,220uF,6.3V,20%,Pitch=2.5mm,D=6.3mm	C6033, C6040
06-22111-12	Alu Electrolytic Capacitor	CD263X,220uF,16V,±20%,F2.5 D=6.3	C6020, C6021
06-33121-09	Alu Electrolytic Capacitor	CD284,330uF,25V,±20%,F5.0,D=8	C6103, C6201
06-10011-03	Alu Electrolytic Capacitor	CD263(X),10uF,16V,±20%,105°C,F2.5	C6126
25-22312-09	Polypropylene Film Capacitor	CBB11-100V-223J R5	C6056, C6063, C6066, C6079
25-22561-00	Metallized Polyester Film Capacitor	CL23B,2.2uF,63V,±10%,C241J225K2S1000	C6014, C6045

C390DD BOM

78-015002-0	Transistor Washer	TW-5	
78-013008-1	Insulated Cushion	SQ9418, SPK-4	
		PCB	
A16-39008-21	C390DD Phono PCB	C390DD Phono PCB	
		Transistor	
31-00114-05	Digital transistor	DTC114EKA	Q9518, Q9519
		Diode	
33-44148-17	Switch Diode	1N4148W-NR	D9500, D9501
		Capacitor	
26-10151-02	ceramic capacitor	100pJ,50V,1206,NPO	C9503, C9510, C9528, C9535
26-18151-01	ceramic capacitor	180pJ,50V,0805,NPO	C9505, C9508, C9530, C9533
26-82151-01	ceramic capacitor	820pJ,50V,0805,NPO	C9506, C9531
26-10212-01	ceramic capacitor	1nJ,100V,0805,NPO	C9544, C9545, C9546, C9547
26-10421-01	ceramic capacitor	100nK,25V,0805,X7R	C9501, C9513, C9518, C9520, C9521, C9523, C9526, C9538
		Resistor	
07-98209-92	MELF Resistors	MMF204FRE82R,82Ω,1/4W,±1%	R9514, R9542
07-91000-92	MELF Resistors	MMF204FRE100R,100Ω,1/4W,±1%	R9512, R9540
07-92200-92	MELF Resistors	MMF204FRE220R,220Ω,1/4W,±1%	R9501, R9523, R9529, R9551
07-92550-92	MELF Resistors	MMF204FRE255R,255Ω,±1%	R9519, R9547
07-95600-92	MELF Resistors	MMF204FRE560R,560Ω,1/4W,±1%	R9506, R9534
07-95900-92	MELF Resistors	MMF204FRE590R,590Ω,1/4W,±1%	R9500, R9522, R9528, R9550
07-91102-92	MELF Resistors	MMF204FRE11K,11KΩ,1/4W,±1%	R9516, R9544
07-91302-92	MELF Resistors	MMF204FRE13K,13KΩ,1/4W,±1%	R9553, R9557
07-92402-92	MELF Resistors	MMF204FRE24K,24KΩ,1/4W,±1%	R9552, R9556
07-94702-92	MELF Resistors	MMF204FRE47K,47KΩ,1/4W,±1%	R9504, R9518, R9532, R9546
07-96802-92	MELF Resistors	MMF204FRE68KR,68K,±1%,1/4W	R9510, R9511, R9538, R9539
07-91333-92	MELF Resistors	MMF204FRE133K,133KΩ,1/4W,±1%	R9515, R9543
07-93300-01	Chip Resistor	330Ω,0805,1/8W,±1%,RC0805FR-07330RL	R9508, R9536
07-94700-01	Chip Resistor	470Ω,0805,1/8W,±1%,RC0805FR-07470RL	R9517, R9545
07-91001-01	Chip Resistor	1KΩ,0805,1/8W,±1%,RC0805FR-0711KL	R9524, R9525, R9526, R9527
07-93001-01	Chip Resistor	3KΩ,0805,1/8W,±1%,RC0805FR-073KL	R9502, R9521, R9530, R9549
07-91602-01	Chip Resistor	16KΩ,0805,1/8W,±1%,RC0805FR-0716KL	R9503, R9520, R9531, R9548
07-92202-01	Chip Resistor	22KΩ,0805,1/8W,±1%,RC0805FR-0722KL	R9554, R9555
07-94702-01	Chip Resistor	47KΩ,0805,1/8W,±1%,RC0805FR-0747KL	R9513, R9541
		IC	
03-05532-00	Dual Op Amp	NE5532P DIP8	U9500
		Resistor	
07-22709-50	Metal Film Resistor	27Ω,1/6W,±1%	R9507, R9535
07-23900-50	Metal Film Resistor	390Ω,1/6W,±1%	R9505, R9533
		Inductor	
A08-01101-01	Inductor(Coil)	100uH,±20%,EMC421-121NS,Pitch=5mm	L9500, L9502
08-01372-00	Inductor(Coil)	TL-372,3.7mH,±10%成型跨距5mm	L9501, L9503
		Relay	
12-02202-15	Signal Relay	HFD31/5 5VDC	RL9500, RL9501
		Transistor	
31-02240-00	Transistor	2SC2240-GR(TPE2,F) TO-92	Q9500, Q9502, Q9503, Q9506, Q9508, Q9510, Q9512, Q9513, Q9516
31-00970-00	Transistor	2SA970-GR(TPE2,F) TO-92	Q9501, Q9504, Q9505, Q9507, Q9509, Q9511, Q9514, Q9515, Q9517
		Capacitor	
06-10111-25	Alu Electrolytic Capacitor	EEUFC1C101H,100uF,16V,±20%,105°C	C9502, C9514, C9517, C9519, C9522, C9524, C9527, C9539, C9598, C9599
06-10111-42	Alu Electrolytic Capacitor	EEUFC1C101H,100uF,16V,±5%,105°C(由06-10111-25分选)	C9515, C9540
06-10111-25	Alu Electrolytic Capacitor	EEUFC1C101H,100uF,16V,±20%,105°C	C9515, C9540
06-10111-28	ALU Electrolytic CAP	UKW1A101MDDTA 100uF,10V,±20%,85°C	C9504, C9509, C9529, C9534

C390DD BOM

06-22021-09	ALU Electrolytic CAP	UKW1H220MDDTD,22uF,25V,±5%,85°C,F2.5(由06-22021-08分选)	C9542, C9543
06-22021-08	ALU Electrolytic CAP	UKW1H220MDDTD,22uF,25V,±20%,85°C,F2.5	C9542, C9543
06-47111-15	ALU Electrolytic CAP	UPW1A471MPDTD,470uF,10V,±20%,105°C	C9500, C9516, C9525, C9541
25-10412-02	ceramic capacitor	CL23B-100V-104K RA	C9594, C9595
25-22212-03	Multilayer Ceramic CAP	ASS21,2.2nF,100V,±5%,Pitch=3.2mm	C9507, C9532
25-24361-03	Multilayer Ceramic CAP	CBB72A-63V-243F, C7.5	C9511, C9536
25-68212-05	Multilayer Ceramic CAP	ASS21,6.8nF,100V,±1%	C9512, C9537

C390DD BOM

00-39000-00	C390DD		
01-39001-00	MAIN BOARD		
02-39001-00	SMT		
	PCB		
A16-39001-21	C390DD MAIN PCB		
	IC		
03-00165-01	8-Bit Serial or Parallel-Input/ Serial-Output Shift Register	HC165	U1003
03-02021-01	POWER-DISTRIBUTION SWITCHES	TPS2021D	U1038
03-00244-07	LOW VOLTAGE CMOS OCTAL BUS BUFFER (3-STATE) WITH 5V TOLERANT INPUTS AND OUTPUTS	SN74AHC244PW	U1020
03-00714-01	TinyLogic. UHS Dual Inverter with Schmitt Trigger Inputs	NC7WZ14P6X	U1022
03-03357-01	SINGLE 5-W SP3T ANALOG SWITCH 5-V/3,3-V 3:1 ANALOG MULTIPLEXER/DEMULTIPLEXER	TS5A3357DCU	U1025, U1031
03-03253-03	DUAL 1 OF 4 FET MULTIPLEXER/ DEMULTIPLEXER	SN74CB3Q3253PWR	U1005, U1012
03-00595-01	Shift Register	SN74HC595DR/ 74HC595D,118/ MM74HC595MX	U1009
or 03-00595-06	8 BIT SHIFT REGISTER	SN74HC595PW	U1009
03-00541-07	Octal Buffer	SN74AHC541DBR	U1010, U1021, U1030
03-03125-01	QUADRUPLE FET BUS SWITCH 2.5-V/3.3-V LOW-VOLTAGE HIGH-BANDWIDTH BUS SWITCH	74CB3Q3125PW	U1013
03-01117-06	Linear Regulator(3.3v)	AMS1117-3.3	U1014, U1026
03-00331-01	High-Speed USB 2.0 (480-Mbps) 1-Port Switch With Single Enable	TS3USB31RSER	U1015, U1023, U1036
03-00125-03	3-STATE Quad buffer	74VHC125MTC/74VHC125MTCX /SN74LVC125APWR	U1016
03-02464-02	BUS EEPROM	24LC64-I/SN	U1018
03-00734-01	TinyLogic UHS Triple Buffer	NC7NZ34	U1001, U1004, U1008, U1017, U1024
03-00716-01	TinyLogic UHS Dual Buffer(TinyLogic 超高速双缓冲器)	NC7WZ16	U1000, U1002, U1006, U1007, U1011, U1019, U1028
03-54331-01	3A 28V INPUT STEP DOWN SWIFT™ DC/DC CONVERTER WITH Eco-mode	TPS54331D	U1035
03-03825-33	Processor Supervisory Circuits	TPS3825-33DBVT	U1033
03-00717-01	TinyLogic UHS Dual Buffer with Schmitt Trigger	NC7WZ17	U1032, U1034
03-00221-02	High-Speed USB 2.0 (480 Mbps) 1:2 Multiplexer/Demultiplexer Switch With Single Enable	TS3USB221ARSER	U1029
03-32460-02	PIC32 MCUs (Microcontrollers) 512KB	PIC32MX460F512L-80I/PT	U1027
33-20012-01	SCHOTTKY DIODE SMD	SS12 SMA	D1002
33-20336-01	SCHOTTKY DIODE SMD	SS36, SCHOTTKY,60V	D1004

C390DD BOM

33-40352-01	Switch Diode	1SS352(TPH3,F),1SS355TE-17	D6201, D6202, D6203, D6204, D6205, D6206, D6210, D6212
33-13609-10	Zener Diode	3.6V, 0.5W LL34	D1003
33-14709-10	Zener Diode	4V7, 1/2W, LL34	D1000, D1001, D1005, D1006
	Transistor		
31-00114-01	Digital transistors (built-in resistors)	DTA114EKA	Q1013
31-00114-05	Digital Transistor(Built in Resistor)	DTC114EKA	Q1003, Q1004, Q1007, Q1008, Q1011, Q1014, Q1000, Q1012
31-02301-01	P-Channel Enhancement Mode MOSFET	APM2301	Q1001, Q1002, Q1005, Q1006, Q1009, Q1010
	Crystal		
04-22452-02	Crystal	HLX-O-3-6-24.576M-1020-1060-1,24.576MHz 10ppm	U1037
04-18001-01	Crystal	8.000MHZ,HC-49/SMD8.0000MHz 18pF/ECS-80-18-5PX-TR	Y1000
	Inductor		
08-04609-01	Ferrite Bead SMD	BEAD,600 OHM@100MHZ,0.5A,0805	L1002, L1003
08-04100-08	chip inductor	10uH	L1000
08-05100-01	chip inductor	10uH	L1001
	Capacitor		
26-20051-00	Ceramic Chip Capacitor	20pF,50V,±5%,NP0,0603	C1046, C1053
26-27051-00	Ceramic Chip Capacitor	27PF,50V,±5%,NP0,0603	C1084
26-33151-10	Ceramic Chip Capacitor	330PF,50V,±5%,X7R,0603	C1006, C1020, C1023, C1025, C1030
26-39151-00	Ceramic Chip Capacitor	390PF,50V,±5%,NP0,0603	C1062
26-10251-10	Ceramic Chip Capacitor	1nJ,50V,0603,NPO	C1063, C1065, C1066
26-22251-00	Ceramic Chip Capacitor	2.2nF,50v,±5%,NP0,0603	C1054
26-10351-00	Ceramic Chip Capacitor	10nK,50V,0603,X7R	C1039, C1040, C1163, C1164
26-15321-00	Ceramic Chip Capacitor	15nK,25V,0603,X7R	C1073
26-10411-00	Ceramic Chip Capacitor	100nF,16V 0603, X7R,±10%	C1000, C1001, C1002, C1003, C1004, C1005, C1007, C1008, C1009, C1010, C1012, C1013, C1015, C1019, C1021, C1022, C1024, C1027, C1028, C1029, C1032, C1033, C1034, C1035, C1036, C1037, C1038, C1041, C1042, C1043, C1047, C1049, C1052, C1055, C1056, C1059, C1060, C1069, C1071, C1074, C1159, C1160, C1161, C1162
26-10660-00	Ceramic Chip Capacitor	10uF,0603,6.3V,X5R,±5%	C1011, C1014
26-10611-01	Ceramic Chip Capacitor	10uF,10V,0805,X5R,±5%	C1016, C1171, C1141, C1119, C1155
26-22351-01	Ceramic Chip Capacitor	22nK,50V,0805,X7R	C1077, C1078, C1079, C1081, C1082
26-10451-11	Ceramic Chip Capacitor	100nK,50V,0805,X7R,±10%	C1058
26-10451-01	Ceramic Chip Capacitor	100nZ,50V,0805,Y5V	C1061
26-22521-01	Ceramic Chip Capacitor	2.2uF,±10%,25V,X5R,0805	C1068
26-22660-11	Ceramic Chip Capacitor	22U,6.3V,±10%,X5R, 0805	C1017, C1018, C1026, C1031, C1050, C1057, C1064, C1072
	Resistor		
07-90000-00	Chip Resistor	0R	R1000, R1001, R1002, R1005, R1012, R1013, R1052, R1055, R1057, R1058, R1081
07-91009-00	Chip Resistor	10Ω,0603, 1/10W,±1%	R1091

C390DD BOM

07-90330-00	Chip Resistor	33Ω,0603,1/10W,±5%,RC0603JR-0733RL	R1121
07-93909-00	Chip Resistor	39Ω,0603,1/10W,±1%,RC0603FR-0739RL	R1108, R1109
07-91000-00	Chip Resistor	100Ω,0603,1/10W,±1%	R1003, R1004, R1006, R1008, R1010, R1011, R1014, R1015, R1016, R1017, R1019, R1020, R1022, R1024, R1026, R1034, R1035, R1036, R1037, R1038, R1039, R1040, R1046, R1048, R1049, R1066, R1071, R1076, R1077, R1079, R1080, R1083, R1088, R1089, R1110
07-90121-00	Chip Resistor	120Ω,0603,1/10W,±5%	R1043, R1062
07-91001-00	Chip Resistor	1KΩ,0603,1/10W,±1%	R1041, R1042
07-94701-00	Chip Resistor	4.7KΩ,0603,1/10W,±1%	R1087
07-90103-00	Chip Resistor	10KΩ,0603,1/10W,±5%,RC0603JR-0710KL	R1007, R1018, R1029, R1030, R1031, R1032, R1033, R1047, R1051, R1053, R1056, R1061, R1063, R1068, R1069, R1072, R1073, R1074, R1075, R1093, R1095, R1096, R1099, R1100, R1101, R1122, R1189
07-90273-00	Chip Resistor	27KΩ,0603,1/10W,±5%	R1086
07-90473-00	Chip Resistor	47KΩ,0603,1/10W,±5%	R1119, R1120
07-91003-00	Chip Resistor	100KΩ,0603,1/10W,±1%	R1067, R1070
07-90105-00	Chip Resistor	1M,0603,±5%,1/10W	R1085
07-90100-01	Chip Resistor	10Ω,0805,1/8W,±5%	R1028
07-91000-01	Chip Resistor	100Ω,0805,1/8W,±1%	R1111, R1112, R1114, R1115
07-91621-01	Chip Resistor	1.62KΩ,0805,1/8W,±1%	R1107
07-99091-01	Chip Resistor	9.09KΩ,0805,1/8W,±1%,RC0805FR-079K09L	R1105
07-95362-01	Chip Resistor	53.6KΩ,0805,1/8W,±1%	R1118
07-91153-01	Chip Resistor	115KΩ,0805,1/8W,±1%	R1117
07-93323-01	Chip Resistor	332KΩ,0805,1/8W,±1%	R1106
07-90470-10	R Networks	47R,0603X4,1/10W,±5%	R1102
07-90121-10	R Networks	120R,0603X4,1/10W,±1%	R1021, R1023, R1025, R1027, R1044, R1045, R1050, R1054, R1059, R1060, R1064, R1065, R1090, R1092, R1094, R1097
07-90103-10	R Networks	10k,0603X4,1/10W,±5%	R1009
	CAPACITOR		
06-33121-09	Alu Electrolytic Capacitor	CD284,330uF,25V,±20%,F5.0,D=8	C1067
06-22111-32	Alu Electrolytic Capacitor	CD284,220uF,10V,±20%,F2.5,D6.3	C1085
06-47111-12	Alu Electrolytic Capacitor	CD263,470uF,16V,±20%,F5.0	C1051
06-33160-01	Alu Electrolytic Capacitor	HCN,330uF,6.3V,±20%,F3.5	C1070, C1076
06-33160-08	Alu Electrolytic Capacitor	CD284,330uF,6.3V,±20%,F3.5	C1075
01-39003-00	FPP BOARD		
	PCB		
A16-39003-21	C390DD FPP PCB		
	IC		
03-01117-01	Linear Regulator	LM1117MPX-5.0/AMS1117-5.0	U3007
03-00734-01	Buffer	NC7NZ34K8X	U3006
03-00125-06	Buffer	SN74AHC1G125DCK	U3004
03-00165-01	Shift Register	SN74HC165D/MM74HC165M/74HC165D	U3008
03-00244-08	Octal Buffer	SN74HCT244PWR	U3003, U3005
03-01826-21	MCU	PIC18F26K20-I/SS(烧C390DD程序)	U3002
03-01826-01	MCU	PIC18F26K20-I/SS,SSOP-28	U3002
03-02985-33	Ragulator	LP2985-33DBVR	U3010

C390DD BOM

	transformer		
22-00012-00	VFD TR	C390DDV1	T3000
	Diode		
33-17509-10	Zener Diode	7.5V, 0.5W, LL34	D3004
33-40352-01	Switch Diode	1SS352(TPH3,F),1SS355TE-17	D3002, D3003, D3011, D3012, D3013, D3014
33-40021-11	Switch Diode	BAV21W	D3006, D3007, D3009
33-16809-10	Zener Diode	6.8V, 0.5W, LL34	D3008
33-16209-10	Diodes	6V2, 1/2W LL34	D3001
33-05819-01	DIODE SCHOTTKY	1N5819HW-7-F, 40V, 1A	D3015
33-40054-00	Schottky Diode	BAT54S, SOT23	D3010
33-13609-10	Zener Diode	3V6	D3000
	Transistor		
31-01815-03	Transistor	2SC1815 SOT23	Q3008
31-00114-01	Digital transistor	DTA114EKA	Q3001, Q3002, Q3003, Q3004
31-00114-05	Digital Transistor	DTC114EKA	Q3005, Q3006, Q3007
31-02301-01	P-CH MOSFET	APM2301CAC, SOT23, Tape	M3000
31-03303-01	NPN EPITAXIAL TYPE	2SC3303-Y	Q3009
	Inductor		
08-04300-01	Ferrite Bead SMD	BMB2A0300LN2	L405
08-04110-00	Ferrite Bead SMD	CBG321609U110	L3003
	Capacitor		
26-33151-10	Ceramic Chip Capacitor	330PF, 50V, ±10% (X7R) 0603	C3010, C3011, C3012, C3013
26-10351-00	Ceramic Chip Capacitor	10nK,50V,0603,X7R	C3027, C3028
26-10411-00	Ceramic Chip Capacitor	100nF,16V 0603, X7R,±10%	C3002, C3003, C3004, C3005, C3006, C3008, C3020
26-47421-00	Ceramic Chip Capacitor	470nZ,25V,0603,Y5V	C3000
26-10212-01	Ceramic Chip Capacitor	1nJ,100V,0805,NPO	C3025, C3026
26-10351-01	Ceramic Chip Capacitor	10nK,50V,0805,X7R	C3039, C3040
26-10411-01	Ceramic Chip Capacitor	100nF,16V 0805, X7R,±10%	C3007,C3014, C3015, C3041, C3042
26-10412-01	Ceramic Chip Capacitor	100nK,100V,X7R,0805	C3034
26-10611-01	Ceramic Chip Capacitor	10uF,0805,10V,C0805C106M8PACTU	C3019, C3024
26-22660-11	Alu Electrolytic Capacitor	22uF, 6.3V, X5R, 0805	C3001, C3017, C3018
26-22621-03	Ceramic Chip Capacitor	22uF,25V,±10%,X5R,1210	C3021
26-10412-02	Ceramic Chip Capacitor	100nK,100V,1206,X7R	C3009, C3038
26-10621-12	Ceramic Chip Capacitor	10uF, 25V, X5R, 1206, C3216X5R1E106KT	C3036, C3037
	Resistor		
07-90000-00	Chip Resistor	0Ω,0603,1/10W,±5%	R3007, R3008, R3009, R3010
07-91000-00	Chip Resistor	100Ω,0603,1/10W,±1%	R3000, R3005, R3014, R3015, R3017, R3018, R3019, R3020, R3021, R3061, R3100
07-90121-00	Chip Resistor	120Ω,0603,1/10W,±5%,RC0603JR-07120RL	R3012
07-90102-00	Chip Resistor	1KΩ,0603,1/10W,±5%,RC0603JR-071KL	R3023, R3024
07-91201-00	Chip Resistor	1.2KΩ,0603,1/10W,±1%,RC0603FR-071K2L	R3043, R3046
07-90103-00	Chip Resistor	10KΩ,0603,1/10W,±5%	R3002, R3035, R3036, R3038
07-92203-00	Chip Resistor	220KΩ,0603,1/10W,±1%,RC0603FR-07220KL	R3003
07-91009-01	Chip Resistor	10Ω,0805,1/10W,±1%,RC0805FR-0710RL	R3058, R3059, R3060
07-93300-01	Chip Resistor	330Ω,0805,1/8W,±1%,RC0805FR-07330RL	R3026, R3027, R3028

C390DD BOM

07-90102-01	Chip Resistor	1KΩ,0805,1/8W,±5%,RC0805JR-071KL	R3025
07-91201-01	Chip Resistor	1.2KΩ,0805,1/8W,±1%,RC0805FR-071K2L	R3056, R3057
07-90103-01	Chip Resistor	10KΩ,0805,1/8W,±5%,RC0805JR-0710KL	R3022, R3029
07-90223-01	Chip Resistor	22KΩ,0603,1/10W,±5%,RC0805JR-0722KL	R3047
07-94702-01	Chip Resistor	47KΩ,0805,1/8W,±1%,RC0805FR-0747KL	R3049
07-90471-02	Chip Resistor	470Ω,1206,1/4W,±5%,RC1206JR-07470RL	R3016
07-90223-02	Chip Resistor	22KΩ,1206,1/4W,±5%,RC1206JR-0722KL	R3001
07-90470-03	Chip Resistor	47Ω,1210,1/4W,±5%,RC1210JR-0747RL	R3048
07-90151-03	Chip Resistor	150Ω,1210,1/2W,±5%,RC1210JR-07150RL	R3055
07-90121-10	Chip Resistor Network	120Ω,0603x4,1/10W,±1%	R3004, R3006, R3011, R3013
07-90103-00	Chip Resistor	10KΩ,0603,1/10W,±5%,RC0603JR-0710KL	R3030, R3031, R3032, R3033, R3039, R3040, R3041, R3042
	Resistor		
07-20000-51	Chip Resistor	0Ω,1/4W,±5%	R3034, R3037
	Switch		
11-04101-05	TACT SW	IT-1102A-1160	K3000, K3001, K3002, K3003, K3004, K3005, K3006, K3007
	IC		
03-00141-00	IR Receiver	GP1UXC41QS	U3000
	Diode		
33-50565-12	Photo-Diode	蓝橙红 BL-BB3JCUB2C4V-1-10F 蓝光波长范围	D3005
	Capacitor		
06-10121-12	Alu Electrolytic Capacitor	CD284,100uF,25V,±20%,105°C,F5.0	C3016
06-47012-03	Alu Electrolytic Capacitor	CD284,47uF,100V,±20%,F5.0	C3035
06-22111-33	Alu Electrolytic Capacitor	CD284,220uF,16V,±20%,F2.5	C3022, C3023
06-47111-12	Alu Electrolytic Capacitor	CD263,470uF,16V,±20%,F5.0	C3043
	Connector		
23-00128-02	VFD DISPLAY	CIG128X3201(短腿)	U3001
75-230001-0	VFD Cover Sheet	PC Black UL94V-0 T=0.45mm	用12mm宽3M双面胶贴于显示屏上
67-048002-0	IR Bracket	Tin plated 头部喷漆	
66-048002-0	IR Bracket	Tin plated	
13-22504-05	Connector Socket	XHB 2 .5A-4AW	J3002
13-12505-14	Connector	2.54mm间距, 5Pin, CNT-M254-1*5-GS-5.9/3-N	CON3000
14-39024-10	Connector Wire	2.0mm间距, 24Pin, L=250mm, CNT-C200-24-250	J3010
	Encode BOARD		
	PCB		
A16-39014-21	C390DD Encode PCB		
	Resistor		
07-91002-00	Chip Resistor	10KΩ,0603,1/10W,±1%	R3145, R3146
07-90103-00	Chip Resistor	10KΩ,0603,1/10W,±5%	R3044, R3045
26-10611-01	Ceramic Chip Capacitor	10uF,0805,10V,C0805C106M8PACTU	C3029
26-10411-00	Ceramic Chip Capacitor	100nF,16V 0603, X7R,±10%	C3030, C3031
	ENCODE		
J37-16243-00	ENCODE	EC16B243040F	S3000
	SPDIF BOARD		
	PCB		
A16-39004-23	C390DD SPDIF PCB		

C390DD BOM

IC			
03-00734-01	Buffer	NC7NZ34K8X	U4006
03-00716-01	Buffer	NC7WZ16P6X	U4005, U4007
03-01117-18	Regulator	LM1117MPX-1.8/AMS1117-1.8	U4003
03-07125-01	BUFFER	NC7SZ125P5X	U4002, U4004, U4008
03-01117-33	Regulator	LM1117MPX-3.3/AMS1117-3.3	U4001
03-04192-01	SPDIF interface	DIX4192IPFB	U4000
03-00006-01	VERY LOW CAPACITANCE ESD PROTECTION	USBLC6-2SC6	D4002, D4003, D4005
Diode			
33-40352-01	Switch Diode	1SS352(TPH3,F),1SS355TE-17	D4000, D4001, D4010, D4011, D4012, D4013
Transistor			
31-00114-05	Digital transistor	DTC114EKA	Q4000
Inductor			
08-04609-01	Ferrite Bead SMD	BEAD,600 OHM@100MHZ,0.5A,0805	L4000, L4001, L4002
Capacitor			
26-10411-00	Ceramic Chip Capacitor	100nF,16V 0603, X7R,±10%	C4006, C4011, C4016, C4017, C4018, C4021, C4024, C4027, C4028, C4035, C4040, C4102, C4103, C4104
26-10251-11	Ceramic Chip Capacitor	1nJ,50V,0805,NPO	C4000, C4008
26-10351-11	Ceramic Chip Capacitor	10nJ,50V,0805,NPO	C4004, C4012, C4065, C4100, C4101
26-10411-01	Ceramic Chip Capacitor	100nK,16V,0805,X7R	C4007, C4014, C4031
26-10451-11	Ceramic Chip Capacitor	100nK,50V,0805,X7R,±10%	C4001, C4002, C4003, C4005, C4013, C4025, C4026, C4032, C4033, C4034, C4036, C4037, C4038
26-22660-11	Ceramic Chip Capacitor	22U,6.3V,±10%,X5R, 0805	C4009, C4015, C4020, C4022, C4023, C4029, C4030
Resistor			
07-90000-00	Chip Resistor	0R	R4012, R4018
07-94708-00	Chip Resistor	4.7Ω,0603,1/10W,±1%,RC0603FR-074R7L	R4032
07-93309-00	Chip Resistor	33Ω,0603,1/10W,±1%,RC0603FR-0733RL	R4006, R4009, R4033
07-99319-00	Chip Resistor	93.1Ω,0603,1/10W,±1%,RC0603FR-0793R1L	R4027
07-91000-00	Chip Resistor	100Ω,0603,1/10W,±1%	R4002, R4003, R4004, R4014, R4015, R4022, R4023, R4025, R4026, R4028, R4030, R4031
07-91100-00	Chip Resistor	110Ω,0603,1/10W,±1%,RC0603FR-07110RL	R4001
07-92050-00	Chip Resistor	205Ω,0603,1/10W,±1%,RC0603FR-07205RL	R4024, R4029
07-94701-00	Chip Resistor	4.7KΩ,0603,1/10W,±1%	R4020
07-91002-00	Chip Resistor	10KΩ,0603,1/10W,±1%	R4017
07-94708-01	Chip Resistor	4.7Ω,0805,1/8W,±1%,RC0805FR-074R7L	R4010, R4013
07-90100-01	Chip Resistor	10Ω,0805,1/8W,±5%,RC0805JR-0710RL	R4008, R4100, R4101
07-93309-01	Chip Resistor	33Ω,0805,1/8W,±1%,RC0805FR-0733RL	R4019, R4021
07-97509-01	Chip Resistor	75Ω,0805,1/8W,±1%,RC0805FR-0775RL	R4005, R4007
07-91000-01	Chip Resistor	100Ω,0805,1/8W,±1%	R4000
07-91002-01	Chip Resistor	10KΩ,0805,1/8W,±1%,RC0805FR-0710KL	R4034

C390DD BOM

	Capacitor		
06-10121-12	Alu Electrolytic Capacitor	CD284, 100uF, 25V, ±20%, 105°C, F5.0	C4019
	Connector		
03-00147-01	Optical Receive	TORX147L(25M,F,T)	OP4000, OP4001
03-01180-01	Light Transmitting	DLT1180A-2(25M)	OP4002
J17-09003-28	Mic Connector	NC3FAAH2	J4000
17-01003-16	3RCA	AV3-8.4-13B/EL	J4001
22-82020-01	Common Inductor	T8-20/20-1.8mH	T4001, T4002, T4003, T4004
01-39005-00	INT BOARD		
	PCB		
A16-39005-23	C390DD INT PCB		
	IC		
03-03221-02	RS232 Interface	MAX3221CAE+/MAX3221CDBR/MAX3221EEEAE	U5001
03-00717-01	Buffer	NC7WZ17P6X	U5000
	Diode		
33-44148-17	1N4148W-NR,SOD123	1N4148	D5000, D5001
33-40352-01	Switch Diode	1SS355TE-17	D5004, D5005, D5006, D5007, D5008, D5009, D5014
33-11200-11	Zener Diode SMD	12V,1/2W, LL34	D5010, D5011, D5012, D5013
	Capacitor		
26-47351-00	Ceramic Chip Capacitor	47nK,50V,0603,X7R	C5003
26-10411-00	Ceramic Chip Capacitor	100nF,16V 0603, X7R,±10%	C5000, C5002, C5004, C5011, C5013, C5018
26-47421-00	Ceramic Chip Capacitor	470nZ,25V,0603,Y5V	C5009, C5015, C5016
26-22051-01	Ceramic Chip Capacitor	22PJ,50V,0805,NPO	C5005, C5017
26-10151-11	Low ESL Feed Through	CKD510X5R1H101ST/NFM21CC101U1H3 0805,X5R,100p,50V	C5012, C5014
26-22151-01	Ceramic Chip Capacitor	220pF,50V,0805, 10%, X7R	C5019, C5021
26-10411-01	Ceramic Chip Capacitor	100nK,16V,0805,X7R	C5006
26-22660-11	Ceramic Chip Capacitor	22U,6.3V,±10%,X5R, 0805	C5001, C5008, C5010
	Resistor		
07-90121-00	Chip Resistor	120Ω,0603,1/10W,±5%,RC0603JR-07120RL	R5006, R5008, R5015
07-91001-00	Chip Resistor	1KΩ,0603,1/10W,±1%,RC0603FR-071K1L	R5019
07-92201-00	Chip Resistor	2.2KΩ,0603,1/10W,±1%,RC0603FR-072K2L	R5005
07-90472-00	Chip Resistor	4.7KΩ,0603,1/10W,±5%,RC0603JR-074K7L	R5020
07-96801-00	Chip Resistor	6.8KΩ,0603,1/10W,±1%,RC0603FR-076K8L	R5011
07-91002-00	Chip Resistor	10KΩ,0603,1/10W,±1%,RC0603FR-0710K1L	R5003, R5007, R5009, R5010
07-93908-01	Chip Resistor	3.9Ω,0805,1/8W,±1%,RC0805FR-073R9L	R5000, R5002
07-91009-01	Chip Resistor	10Ω,0805,1/10W,±1%,RC0805FR-0710RL	R5001, R5004, R5013, R5014
07-94709-01	Chip Resistor	47Ω,0805,1/8W,±1%,RC0805FR-0747RL	R5017, R5018
07-91000-01	Chip Resistor	100Ω,0805,1/8W,±1%	R5012, R5016
	Connector		
13-21015-01	FPC Connector SMD	15Pin,1.0-9-15PWB	J5002
	Transistor		

C390DD BOM

31-01220-00	Power Transistor	KSA1220AYSTU, TO-126	Q5000
	Capacitor		
06-10121-02	Alu Electrolytic Capacitor	CD263(X),100uF,25V,±20%,105°C,F5.0	C5007
	Connector		
13-22504-20	Connector Socket	XHB2.5A-4A, Gold plated SIP4A	J5010
17-08009-00	RS232 Socket	RS232/F,7906-09FHA	J5004
17-02002-09	Phone Jack	SCJ351P00WS0BP6G	J5001
17-01002-03	2RCA	*2 holes RJ-21V01	J5005
17-02001-04	3.5mm phone jack	ST-323B-04 / CKX-3.5-02-3P	J5008
	USB BOARD		
	PCB		
A16-39007-21	C390DD USB PCB		
	IC		
03-04160-01	DC/DC CONVERTER	ADUM4160BRWZ	U7013
03-00151-33	Linear Regulator	ADP151AUJZ-3.3-R7	U7016
03-02021-01	POWER-DISTRIBUTION SWITCHES	TPS2021D	U7005
03-48162-03	SDRAM	MT48LC16M16A2P-75:D	U7000
03-01020-01	USB Streaming Controller	TAS1020BPFB	U7012
03-03825-33	RESET	TPS3825-33DBVT	U7007
03-01963-33	Linear Regulator	TL1963A-33KTTR	U7001
orN03-38500-33	Linear Regulator	LP38500-3v3	U7001
03-54331-01	DC/DC CONVERTER	TPS54331D	U7002
03-02464-13	BUS EEPROM	24LC64-I/SN	U7009
03-02464-02	BUS EEPROM	24LC64-I/SN	U7009
03-00032-03	MCU	AT32UC3A0512-ALUT	U7003
03-00221-02	High-Speed USB 2.0 (480 Mbps) 1:2 Multiplexer/Demultiplexer Switch With Single Enable	TS3USB221ARSER	U7006
03-00714-01	TinyLogic. UHS Dual Inverter with Schmitt Trigger Inputs	NC7WZ14P6X	U7008
03-00244-07	Octal Buffer	SN74AHC244PW	U7010, U7011
03-29800-01	CMOS SINGLE VOLTAGE 3V ONLY FLASH MEMORY	MX29LV800CBTI-70G	U7018
	Diode		
33-50805-45	LED(yellow green)	L-C170KGCT EC04-0805GC	D7001
33-20336-01	SCHOTTKY DIODE SMD	SS36, SCHOTTKY,60V	D7000
33-00502-01	ESD Protection diode	PRTR5V0U2X,215	D7002
33-40352-01	Switch Diode	1SS355TE-17	D7006, D7007, D7008, D7009, D7010, D7011
	Crystal		
04-11202-05	CRYSTAL	12MHz, CL=20pF, ±30ppm, IB-F-12.000M-20-3050-2070	XC7001
04-16000-01	CRYSTAL	6.000000 MHZ HCM49,HCM49-6.000MABJT	XC7002
04-22452-06	VCXO	24.576MHz, C3391-24.576MHz,SMD 5*7	U7014
or 04-22452-09	Oscillator	SRTD3T-24.576MHZ TR	U7014
04-22252-03	VCXO	22.5792MHz, C3398-22.579200MHz,SMD 5*7	U7015
or 04-22252-05	Oscillator	SRTD3T-22.5792MHZ TR	U7015

C390DD BOM

04-11122-01	CRYSTAL	HC-49/SMD, 11.2896MHz,CL=20pF,FL=20PP	XC7000
	Inductor		
08-04100-08	Power Inductor	10uH,MSS7341-103ML	L7002
08-04601-05	FERRITE BEADS	600ohm@100MHz	L7004
08-04102-31	Ferrite Bead SMD	742792662, 1000ohm@100MHz	L7000, L7001, L7003, L7011, L7012
08-04301-04	Ferrite Bead SMD	742792035, 300ohm@100MHz, ±25%, 0.3A	L7007
08-04331-06	Ferrite Bead SMD	742792037, 330ohm@100MHz, ±25%, 2A	L7006, L7008, L7010, L7107
08-04100-27	Ferrite Bead SMD	742792011,10ohm@100MHz, ±25%, 3A	L7005, L7009
	Capacitor		
26-22051-00	Ceramic Chip Capacitor	22pJ,50V,0603,NPO	C7025, C7026, C7021,C7022
26-33051-00	Ceramic Capacitor SMD	33pF, 5%, 50V, NPO	C7098, C7099, C7100, C7101
26-10151-00	Ceramic Chip Capacitor	100pJ,50V,0603,NPO	C7067
26-22112-00	Ceramic Chip Capacitor	0603, 220pJ, 100V, NPO	C7300
26-47151-00	Ceramic Chip Capacitor	470pJ,50V,0603,NPO	C7047
26-10251-00	Ceramic Chip Capacitor	1nK,50V,0603,X7R	C7090, C7092
26-27251-10	Ceramic Chip Capacitor	2n7J,50V,0603,NPO	C7031, C7032, C7033, C7034, C7040
26-22351-00	Ceramic Chip Capacitor	22nK,50V,0603,X7R	C7122, C7130
26-33351-00	Ceramic Chip Capacitor	33nK,50V,0603,X7R	C7015, C7017, C7035, C7036, C7037, C7038, C7041, C7045, C7049, C7052, C7059, C7060, C7061, C7062, C7063, C7064
26-10411-00	Ceramic Chip Capacitor	100nF,16V 0603, X7R	C7317, C7318
26-10421-10	Ceramic Chip Capacitor	100nK,25V 0603,X7R	C7014, C7016, C7019, C7023, C7027, C7028, C7029, C7039, C7044, C7048, C7050, C7051, C7054, C7055, C7056, C7057, C7058, C7068, C7069, C7071, C7077, C7078, C7007, C7079, C7081, C7085, C7095, C7096, C7120
26-22560-00	Ceramic Chip Capacitor	2.2uF,0603,6.3V,X5R,06036D225KAT2A	C7030, C7042, C7046
26-47560-00	Ceramic Chip Capacitor	4.7UF 6.3V X5R 0603	C7013, C7018, C7024, C7043, C7053
26-47511-00	Ceramic Chip Capacitor	4.7uK,10V,0603,X5R	C7350
26-10611-10	Ceramic Chip Capacitor	10uK,10V,0603,X7R	C7097
26-27051-01	Ceramic Chip Capacitor	27PJ,50V,0805,NPO	C7010, C7065, C7066
26-33051-01	Ceramic Chip Capacitor	33PJ,50V,0805,NPO	C7076, C7084
26-39151-01	Ceramic Chip Capacitor	390pJ,50V,0805,NPO	C7009
26-10251-11	Ceramic Chip Capacitor	1nJ,50V,0805,NPO	C7070
26-15351-01	Ceramic Chip Capacitor	15nK,50V,0805,X7R	C7011
26-22351-01	Ceramic Chip Capacitor	22nK,50V,0805,X7R	C7123
26-10421-01	Ceramic Chip Capacitor	100nK,25V,0805,X7R	C7001, C7002, C7074, C7075, C7080, C7088, C7094,
26-22511-01	Ceramic Chip Capacitor	2u2F,16V 0805, X7R	C7020
26-22521-01	Ceramic Chip Capacitor	2.2uFK, 25V X5R, 0805,C2012X5R1E225KT	C7003, C7005
26-10611-21	Ceramic Chip Capacitor	10uK,16V,0805,X5R,C2012X5R1C106KT / CC0805KKX5R7BB106	C7086
26-22660-11	Ceramic Chip Capacitor	22uF, 6.3V, X5R, 0805	C7072, C7073, C7082, C7083, C7087, C7093, C7089, C7091
26-22521-03	Ceramic Capacitor SMD	2.2uF,25V1210,10%,X5R	C7006
	Resistor		
07-90000-00	Chip Resistor	0Ω, 0603, ±5%	R7025, R7029, R7030, R7031, R7011, R7101, R7211
07-92708-00	Chip Resistor	2.7Ω,0603,1/10W,±1%	R7039

C390DD BOM

07-94708-00	Chip Resistor	4.7 Ω ,0603,1/10W, \pm 1%,RC0603FR-074R7L	R7005
07-93309-00	Chip Resistor	33 Ω ,0603,1/10W, \pm 1%,RC0603FR-0733RL	R7032, R7044, R7045, R7050, R7051, R7052, R7053, R7054, R7055, R7056, R7057, R7058, R7059, R7060, R7061, R7062, R7063, R7066, R7068, R7111, R7112, R7113, R7114, R7115
07-93909-00	Chip Resistor	39 Ω ,0603,1/10W, \pm 1%,RC0603FR-0739RL	R7027, R7028
07-91000-00	Chip Resistor	100 Ω ,0603,1/10W, \pm 1%,RC0603FR-07100RL	R7129, R7120
07-90121-00	Chip Resistor	120 Ω ,0603,1/10W, \pm 5%,RC0603JR-07120RL	R7015, R7019, R7020
07-91500-00	Chip Resistor	150 Ω ,0603,1/10W, \pm 1%,RC0603FR-07150RL	R7007
07-91501-00	Chip Resistor	1.5K Ω ,0603,1/10W, \pm 1%,RC0603FR-071K5L	R7043
07-90222-00	Chip Resistor	2.2K Ω ,0603,1/10W, \pm 5%	R7036, R7037
07-93091-00	Chip Resistor	3.09K Ω ,0603,1/10W, \pm 1%,RC0603FR-073K09L	R7035
07-90472-00	Chip Resistor	4.7K Ω ,0603,1/10W, \pm 5%,RC0603JR-074K7L	R7009, R7010, R7102, R7103
07-91002-00	Chip Resistor	10K Ω ,0603,1/10W, \pm 1%,RC0603FR-0710KL	R7016, R7110, R7119
07-93602-00	Chip Resistor	36K Ω ,0603,1/10W, \pm 1%,RC0603FR-0736KL	R7048
07-94702-00	Chip Resistor	47K Ω ,0603,1/10W, \pm 1%,RC0603FR-0747KL	R7022, R7023
07-91003-00	Chip Resistor	100K Ω ,0603,1/10W, \pm 1%,RC0603FR-07100KL	R7012, R7014, R7199
07-90000-01	Chip Resistor	0 Ω , 0805, \pm 5%	R7000, R7001, R7327, R7328
07-91009-01	Chip Resistor	10 Ω ,0805,1/10W, \pm 1%,RC0805FR-0710RL	R7065, R7067
07-91000-01	Chip Resistor	100 Ω ,0805,1/8W, \pm 1%	R7126
07-92001-01	Chip Resistor	2K Ω ,0805,1/8W, \pm 1%	R7003
07-91002-01	Chip Resistor	10K Ω ,0805,1/8W, \pm 1%	R7329
07-91052-01	Chip Resistor	10.5K Ω ,0805,1/8W, \pm 1%,RC0805FR-0710K5L	R7002
07-95362-01	Chip Resistor	53.6K Ω ,0805,1/8W, \pm 1%,RC0805FR-0753K6L	R7008
07-91153-01	Chip Resistor	115K Ω ,0805,1/8W, \pm 1%	R7006
07-93323-01	Chip Resistor	332K Ω ,0805,1/8W, \pm 1%,RC0805FR-07332KL	R7004
07-91008-02	Chip Resistor	1 Ω ,1206,1/4W, \pm 1%	R7042
07-90820-10	Chip Resistor NET	82 Ω ,0603X4, \pm 5%,YC164-JR-0782RL	R7024, R7038(?), R7040(?), R7041(?)
07-90121-10	R Networks	120R,0603X4,1/10W, \pm 1%	R7013, R7026, R7046
	Connector		
11-04101-05	TACT SW	IT-1102A-1160	SW7000
13-12510-22	Connector Socket	2x5Pin, CNT-M254-2*5-GS-5.8/3-N	J7002
17-08001-02	USB connector	GL56S08-04B	J7003
17-08001-07	USB Socket	UAR20-4W2100/GL56S05	J7001
13-12506-15	Connector Socket	2x3Pin, CNT-M254-2*3-GS-5.8/3-N	J7000
	Capacitor		
06-22160-05	Alu Electrolytic Capacitor	HCN,6V3,220uF, \pm 20%,F3.5	C7000, C7012
06-10121-11	Alu Electrolytic Capacitor	CD284, 100uF, 25V, \pm 20%, 105 $^{\circ}$ C, F2.5	C7008
06-33121-06	Alu Electrolytic Capacitor	CD289,330uF,25V, \pm 20%,	C7004
01-39009-00			
	PCB		

C390DD BOM

A16-39009-21	Power AMP PCB		
	DIODES		
33-50603-04	SUPER BRIGHT ORANGE	SML-311YTT86	D5
33-20540-02	SCHOTTKY DIODE	B540C-13-F	D3
33-20313-01	DIODE	S3DB-13-F	D2, D11_CHLF, D11_CHRF, D12_CHLF, D12_CHRF, D21, D22
33-40054-00	SCHOTTKY DIODE	BAT54S	D1, D13_PSL, D13_PSR, D17_PSL, D17_PSR, D305_CHL, D305_CHR
33-40054-02	Schottky Rectifier Diode	BAT54J	D18, D20, D23
33-40099-02	Switch Diode	BAV99-7-F	D7, D14_PSL, D14_PSR, D19_PSL, D19_PSR, D301_CHL, D301_CHR, D304_CHL, D304_CHR, D307_CHL, D307_CHR
33-20001-03	ULTRAFAST RECTIFIER	ES1D	D300_CHL, D300_CHR
33-22000-01	SCHOTTKY DIODE	ZHCS2000TA	D4, D6, D8, D15
33-00400-01	SCHOTTKY DIODE	ZHCS400TA	D9, D10
33-12009-10	Zener Diode	2V, 1/2W, LL34	D16
33-13309-09	Zener Diode	BZX84C3V3-7-F, 3.3V, 0.35W	D302_CHL, D302_CHR
33-15109-02	Zener Diode	BZX84C5V1-7-F, 5.1V, 0.35W	D303_CHL, D303_CHR, D306_CHL, D306_CHR
	TRANSISTORS		
31-00493-00	Transistor	FZT493	Q10
31-00846-07	Transistor	BC846B-7-F	Q3, Q4, Q6, Q8, Q12
31-00856-07	Transistor	BC856B-7-F	Q2, Q7
31-00114-05	Digital transistor	DTC114EKA	Q5
31-00593-00	Transistor	XSTR,FMMT593,PNP,100V	Q304_CHL, Q304_CHR
31-07002-01	JFET	2N7002	Q100, Q101, Q102, Q103
31-00003-01	Dual FET	ZXMC3AMCTA	Q1, Q300_CHL, Q300_CHR, Q302_CHL, Q302_CHR
31-01015-03	Transistor	A1015, SOT23	Q9, Q15, Q16
31-01815-03	Transistor	C1815, SOT23	Q11, Q13, Q14, Q17, Q18
	IC		
03-20040-01	DDFA Advanced Feedback Processor	ZXCZA200JC40TA	U1
03-00800-02	DDFA Modulator	ZXCZM800QPATR	U3
03-28502-01	Zetex Voltage Reference	ZR285F02TA	REF1
03-00082-01	OP-AMP	TL082BCD/TL082BCDR	U500_PSL, U500_PSR, U501_PSL, U501_PSR, U502_PSL, U502_PSR
03-05004-13	PWM CONTROL 2.5A STEP-DOWN CONVERTER	AP5004SG-13	U2
03-01117-09	Adjustable voltage regulator	ZLDO1117GTA	U8, U19, U20, U21, U22, U23
03-01100-01	Coupler digital isolator	ADUM1100ARZ	U300_CHL, U300_CHR
03-00337-01	3-Terminal Regulator	LM337IMP, SOT223	U25
03-07865-01	TinyLogic ULP-A 2-Input Exclusive-OR Gate	NC7SV86P5X	U12, U16
03-07125-01	Buffer	NC7SZ125P5X	U11
03-07178-01	Tinylogic Triple Buffer with Schmitt Trigger	NC7NZ17K8X	U5, U10, U13, U14, U15, U301_CHL, U301_CHR, U302_CHL, U302_CHR
03-00774-02	D-Type Flip-Flop	NC7SZ74K8X	U7
03-01806-01	OP-AMP	LT1806CS6	U9
03-49710-01	OP-AMP	LME49710MA/NOPB	U4, U6
03-00339-04	Quad Differential Comparators	LM339ADR	U100
03-04040-25	Precision Micropower shunt voltage reference	LM4040DIM3-2.5 NOPB	U101, U102

C390DD BOM

	RESISTOR		
07-90000-08	Chip Resistor	0R 0402	R163, R149
07-90000-00	Chip Resistor	0Ω, 1/10W, 5%	R107
07-91007-00	Chip resistor	0.1Ω,0603,1/10W,±1%	R179,R180
07-91008-00	Chip resistor	1Ω, 1/10W,±1%	R124, R125
07-91509-00	Chip Resistor	15Ω, 1/10W, ±1%	R19, R20
07-93309-00	Chip Resistor	33Ω, 1/10W,±1%	R33, R34, R35, R36, R51, R53, R55, R76, R78, R79, R80
07-97509-00	Chip Resistor	75Ω, 1/10W, 1%	R11, R12, R17, R18, R44, R45, R47, R119
07-91000-00	Chip Resistor	100Ω, 1/10W, 1%	R43, R64, R66, R203
07-91200-00	Chip Resistor	120Ω, 1/10W, 1%	R52
07-91500-00	Chip Resistor	150Ω,1/10W,±1%	R1, R2, R3, R4, R56, R58, R61, R68, R98, R99, R101, R102, R103, R104, R127, R128
07-92200-00	Chip resistor	220Ω, 1/10W,±1%	R42, R63, R65, R100
07-92400-00	Chip Resistor	240Ω, 1/10W, 1%	R60, R62, R67, R77
07-93300-00	Chip Resistor	330Ω,0603,1/10W,±1%	R111
07-95600-00	Chip Resistor	560Ω, 1/10W,±1%	R57
07-97500-00	Chip Resistor	750Ω, 1/10W,±1%	R9, R10, R74, R109
07-91001-00	Chip Resistor	1KΩ, 1/10W, 1%	R145, R176, R75, R205, R207, R208, R209, R211, R214, R215
07-91201-00	Chip Resistor	1.2KΩ, 1/10W,±1%	R5, R6
07-92001-00	Chip Resistor	2KΩ, 1/10W, ±1%	R195
07-92201-00	Chip Resistor	2.2KΩ,0603,1/10W,±1%	R71, R166, R206, R212, R216, R217, R218, R223, R224
07-92701-00	Chip Resistor	2.7KΩ, 1/10W,±1%	R201, R202
07-93001-00	Chip Resistor	3KΩ, 1/10W, 1%	R187
07-93301-00	Chip Resistor	3K3Ω, 1/10W, 1%	R7, R8, R37, R90, R92, R105, R174
07-93321-10	Chip Resistor	3.32KΩ,0603,1/10W,±0.1%,±25PPM,	R26, R28, R129, R131,
07-93901-00	Chip Resistor	3K9Ω, 1/10W, 1%	R178
07-94301-00	Chip Resistor	4.3KΩ, 1/10W,±1%	R310_CHL, R310_CHR
07-94701-00	Chip Resistor	4K7Ω, 1/10W, 1%	R50,R88, R197,R198,R199,R200, R220, R221
07-96651-00	Chip Resistor	6K65Ω, 1/10W, ±0.1%	R38, R39, R82, R83, R86, R89, R94, R95
07-91002-00	Chip Resistor	10KΩ, 1/10W, ±1%	R112, R113, R177, R230, R231
07-91202-00	Chip Resistor	12KΩ, 1/10W,±1%	R85, R93, R175
07-91802-00	Chip Resistor	18KΩ,0603,1/10W,±1%	R81, R204, R219, R222
07-91003-00	Chip Resistor	100KΩ, 1/10W, 1%	R59
07-91203-00	Chip Resistor	120KΩ,1/10W,±1%	R311_CHL, R311_CHR
07-94702-00	Chip Resistor	47KΩ, 1/10W, ±1%	R87, R303_CHL, R303_CHR, R307_CHL, R307_CHR
07-95362-10	Chip Resistor	53.6KΩ,0603,1/10W,±0.1%, ±25PPM,	R32,R133
07-91073-00	Chip Resistor	107KΩ,0603,1/10W,±0.1%	R40, R84, R91, R96
07-91473-00	Chip Resistor	147KΩ,0603,1/10W,±1%	R188
07-91583-00	Chip Resistor	158KΩ,0603,1/10W,±1%	R189
07-91693-00	Chip Resistor	169KΩ,0603,1/10W,±1%	R196
07-91004-00	Chip Resistor	1MΩ, 1/10W,±1%	R22, R23, R24, R25
07-94704-00	Chip Resistor	4.7MΩ, 1/10W,±1%	R14, R15
07-92708-01	Chip Resistor	2.7Ω, 1/8W,±1%	R302_CHL, R302_CHR, R306_CHL, R306_CHR
07-91509-01	Chip Resistor	15Ω,1/8W,±1%	R41, R97
07-92709-01	Chip Resistor	27Ω, 1/8W,±1%	R301_CHL, R301_CHR
07-93309-01	Chip Resistor	33Ω, 1/8W,±1%	R48, R49, R106, R108
07-95109-01	Chip Resistor	51Ω,0805,1/8W,±1%	R308_CHL, R308_CHR
07-96209-01	Chip Resistor	62Ω, 1/8W,±1%	R69
07-96809-01	Chip Resistor	68Ω,0805,1/8W,±1%,RC0805FR-0768RL	R173_PSL, R173_PSR
07-91020-01	Chip Resistor	102Ω,0805,1/8W, ±1%, RC0805FR-07102RL	R167_PSL, R167_PSR
07-91500-01	Chip Resistor	150Ω, 1/8W, 1%	R70, R121
07-91600-01	Chip Resistor	160Ω, 1/8W, ±1%	R73

C390DD BOM

07-92700-01	Chip Resistor	270Ω, 1/8W,±1%	R305_CHL, R305_CHR
07-91001-01	Chip Resistor	1KΩ, 1/8W, 1%	R46, R72, R154_PSL, R154_PSR
07-91101-01	Chip Resistor	1.1KΩ,1/8W,±1%	R122
07-92201-01	Chip Resistor	2.2KΩ, 1/8W,±1%	R150_PSL, R150_PSR, R168_PSL, R168_PSR
07-92701-01	Chip Resistor	2.7KΩ,0805,1/8W,±1%	R191
07-90332-01	Chip Resistor	3.3KΩ,0805,1/8W,±5%	R184
07-90362-01	Chip Resistor	3K6Ω, ±5%, 0805	R192
07-90392-01	Chip Resistor	3.9KΩ,0805,1/8W,±5%	R185
07-94991-01	Chip Resistor	4.99KΩ,0805,1/8W,±1%,RC0805FR-074K99L	R151_PSL, R151_PSR, R152_PSL, R152_PSR, R161_PSL, R161_PSR, R164_PSL, R164_PSR
07-91002-01	Chip Resistor	10KΩ,0805,1/8W,±1%,RC0805FR-0710KL	R143_PSL, R143_PSR, R159_PSL, R159_PSR, R172_PSL, R172_PSR
07-91432-01	Chip Resistor	14.3KΩ,0805,1/8W,±1%,RC0805FR-0714K3L	R146_PSL, R146_PSR,
07-91652-01	Chip Resistor	16.5KΩ,0805,1/8W,±1%,RC0805FR-0716K5L	R147_PSL, R147_PSR
07-94702-01	Chip Resistor	47KΩ, 1/8W, 1%	R54, R123, R309_CHL, R309_CHR
07-95102-01	Chip Resistor	51KΩ, 1/8W,±1%	R29, R30
07-95602-21	Chip Resistor	56KΩ,0805,1/8W,±0.1%,25PPM	R13, R16
07-96802-01	Chip resistor	68KΩ, 1/8W,±1%	R300_CHL, R300_CHR, R304_CHL, R304_CHR
07-97872-01	Chip Resistor	78.7KΩ,0805,1/8W,±1%	R190
07-98252-01	Chip Resistor	82.5KΩ,0805,1/8W,±1%	R183
07-99532-01	Chip Resistor	95.3KΩ,0805,1/8W,±1%	R186
07-91003-01	Chip Resistor	100KΩ, 1/8W, 1%	R153_PSL, R153_PSR, R155_PSL, R155_PSR, R165_PSL, R165_PSR, R170_PSL, R170_PSR
07-91073-01	Chip Resistor	107KΩ,0805,1/8W,±1%	R193
07-91153-01	Chip Resistor	115KΩ,0805,1/8W,±1%	R194
07-92213-01	Chip Resistor	221KΩ, 0805, 1/8W, 1%	R156_PSL, R156_PSR, R157_PSL, R157_PSR
07-91004-01	Chip Resistor	1MΩ, 1/8W,±1%	R169_PSL, R169_PSR
07-92431-01	Chip Resistor	2K43Ω, ±1%,100ppm/K	R144_PSL, R144_PSR
07-96491-01	Chip Resistor	6K49Ω, ±1%,100ppm/K	R158_PSL, R158_PSR
07-96811-01	Chip Resistor	6K81Ω,±1%,100ppm/K	R171_PSL, R171_PSR
07-91008-02	Chip Resistor	1Ω,1206,1/4W,±1%	R137_CHLF, R137_CHRF, R138_CHLF, R138_CHRF, R139_CHLF, R139_CHRF
07-91009-02	Chip Resistor	10Ω,1206,1/4W,±1%	R136_CHLF, R136_CHRF, R110_CHLF, R110_CHRF
07-92702-02	Chip Resistor	27KΩ,1206,1/4W,±1%	R181_CHLF, R181_CHRF, R182_CHLF, R182_CHRF
07-97501-04	Chip Resistor	7.5KΩ,2010,3/4W,±1%	R162_PSL, R162_PSR
07-94701-83	Professional MELF Resistors	4.7KΩ,0207,1W, ±1%,CSR0207FTDT4701	R135_CHLF, R135_CHRF
07-70103-03	NTC	10KΩ, ±5%	TH300_CHL, TH300_CHR
07-90330-10	R Networks	33Ω×4, ±5%, 0603×4	R1134
CAPACITOR			
26-10411-08	Ceramic Chip Capacitor	100nF,16V,X7R,±10%	C75, C76, C77, C78, C80, C81, C120, C122
26-10051-00	Ceramic Capacitor SMD	10pF, 5%, 50V, NPO	C6, C7, C8, C9, C58, C119
26-12051-10	Ceramic Capacitor SMD	12pJ,50V,0603,NPO	C71, C72
26-33051-00	Ceramic Capacitor SMD	33pF, 5%, 50V, NPO	C39, C51, C53, C54, C56, C57, C60, C61, C310_CHL, C310_CHR, C311_CHL, C311_CHR, C316_CHL, C316_CHR
26-10151-00	Ceramic Capacitor SMD	100pF, 5%, 50V, NPO	C178_PSL, C178_PSR
26-10112-10	Ceramic Capacitor SMD	100pJ,100V,0603,NPO	C10, C11
26-10122-00	Ceramic Capacitor SMD	100pJ,200V,0603,NPO	C128
26-27151-00	Ceramic Chip Capacitor	270pJ,50V,0603,NPO	C14, C15
26-39151-00	Ceramic Chip Capacitor	390PJ, 5%, 50V, NPO	C16, C17
26-47151-00	Ceramic Capacitor SMD	470pF, 5%, 50V, NPO	C18, C19
26-68151-00	Ceramic Chip Capacitor	680pJ,50V,0603,NPO	C64, C148

C390DD BOM

26-10251-00	Ceramic Chip Capacitor	1nK,50V,0603,X7R	C213, C214
26-10251-10	Ceramic Chip Capacitor	1nJ,50V,0603,NPO	C185_PSL, C185_PSR, C20, C21, C95, C96, C146, C157, C158, C194, C33, C34, C142, C143
26-47251-10	Ceramic Capacitor SMD	4.7nJ,50V NPO,0603	C181_PSL, C181_PSR
26-68251-10	Ceramic Capacitor SMD	6.8nJ, 50V,0603,NPO	C97, C159
26-10321-00	Ceramic Chip Capacitor	10nJ,25V,0603,NPO	C73, C197
26-15351-00	Ceramic Chip Capacitor	15nF, 10%, 50V, X7R	C183_PSL, C183_PSR
26-10411-00	Ceramic Chip Capacitor	100nF,16V 0603, X7R	C212
26-10451-10	Ceramic Chip Capacitor	100nK,50V,0603,X7R	C186_PSL, C186_PSR, C187_PSL, C187_PSR, C188_PSL, C188_PSR, C189_PSL, C189_PSR, C190_PSL, C190_PSR, C191_PSL, C191_PSR, C302_CHL, C302_CHR, C313_CHL, C313_CHR
26-10511-20	Ceramic Chip Capacitor	1uF, ±10%, 16V, X7R	C12, C13, C24, C25, C35, C36, C48, C49, C52, C79, C83, C84, C85, C86, C87, C88, C89, C90, C91, C92, C93, C94, C98, C99, C101, C102, C103, C104, C105, C106, C107, C108, C109, C110, C111, C112, C113, C114, C118, C121, C127, C136, C139, C140, C141, C144, C145, C198, C199, C200, C303_CHL, C303_CHR, C304_CHL, C304_CHR, C309_CHL, C309_CHR, C315_CHL, C315_CHR
26-10212-01	Ceramic Chip Capacitor	1nJ,100V,0805,NPO	C314_CHL, C314_CHR
26-22251-21	Ceramic Chip Capacitor	2n2J,50V,0805,NPO	C202, C203
26-47221-01	Ceramic Chip Capacitor	4n7J,25V,0805,NPO	C65
26-47212-01	Ceramic Chip Capacitor	4.7nJ,100V,0805,NPO	C175_CHLF, C175_CHRF
26-10351-01	Ceramic Capacitor SMD	10nF, 10%, 50V, X7R	C29, C31, C192, C193
26-10412-01	Ceramic Capacitor SMD	100nF, 10%, 100V, X7R	C37, C70, C124, C137, C150, C162, C166, C171_CHLF, C171_CHRF, C174_CHLF, C174_CHRF, C321_CHL, C321_CHR
26-22421-01	Ceramic Chip Capacitor	220nK,25V,0805,X7R	C299
26-10511-01	Ceramic Chip Capacitor	1uK, 10%, 16V, X7R	C129, C131, C133, C135, C160, C168, C201
26-47521-11	Ceramic Capacitor SMD	4.7uK,25V,X5R,0805	C1, C2, C3, C4, C5, C26, C27, C32, C43, C44, C45, C46, C66, C69, C82, C100, C117, C125, C130, C132, C134, C152, C154, C163, C164, C195, C196, C301_CHL, C301_CHR, C312_CHL, C312_CHR
26-10611-01	Ceramic Capacitor SMD	10uF,0805,10V, X5R	C50
26-10222-12	Ceramic Chip Capacitor	1nJ,200V,1206,NPO,1206	C172_CHLF, C172_CHRF, C204_CHLF, C204_CHRF
26-10521-22	Ceramic Capacitor SMD	1uF, 10%, 25V,X7R	C180_PSL, C180_PSR
26-10611-02	Ceramic Chip Capacitor	10uF, ±10%, 16V, X5R	C147, C155, C156, C161, C167, C169
26-10512-13	Ceramic Capacitor SMD	1uK,100V,1210,X7R	C38, C42
26-10512-03	Ceramic Capacitor SMD	1uF, 100V, ±10%, 1210, X5R	C165, C300_CHL, C300_CHR
26-22512-03	Ceramic Capacitor SMD	2.2uF, 100V, 10%, 1210	C305_CHL, C305_CHR, C306_CHL, C306_CHR, C307_CHL, C307_CHR, C308_CHL, C308_CHR, C317_CHL, C317_CHR, C318_CHL, C318_CHR, C319_CHL, C319_CHR, C320_CHL, C320_CHR
27-47060-02	Tan Capacitor	47uF, ±20%, 6.3V	C22, C23, C67
27-10160-03	Tan Capacitor	100uF, ±20%, 6.3V	C74, C149

C390DD BOM

	INDUCTOR		
08-05100-01	INDUCTOR	10UH	L5
08-04338-00	INDUCTOR	LQM21NNR33K10D_0.33uH	L1
08-04158-00	Inductor SMD	150nH 744302015	L2, L3
08-04727-00	Inductor SMD	72nH 744302007	L4_CHLF, L4_CHRF
08-04100-24	Inductor SMD	74477410,10uH	L12
08-04609-01	BEAD	CBY201209A601T	L6, L7, L8
08-04102-16	BEAD	1000Ω,±25%,100MHz,0603 742792664	L9
	CONNECTORS		
04-11083-01	Oscillator SMD	MXU510P20-3-B20-2L-MJT-108Mhz	X1
	TRANSISTORS		
31-05620-00	MOSFET	IRFB5620PbF	Q301_CHL, Q301_CHR, Q303_CHL, Q303_CHR
	RESISTOR		
07-40107-00	Cement Resistor	RGC3, 0.01Ω, 3W, ±5%, Pitch=9mm	R142_CHLF, R142_CHRF
07-30220-05	Metal Oxide Film Resistor	RY21-3,22Ω,3W,±5%,长引线	R140_CHLF, R140_CHRF, R141_CHLF, R141_CHRF
	CAPACTIOR		
25-10322-02	Metallized Polyester Film Capacitor	CL23B-250V-103J RA	C173_CHLF, C173_CHRF
25-22412-00	Metallized Polyester Film Capacitor	220nF, 100V, 10%	C177_CHLF, C177_CHRF
25-33412-04	Metallize Polypropylene Capacitor	MKP2,330nF / 100V	C176_CHLF, C176_CHRF
25-47222-02	Film capacitor	4.7nF,250V,±1%	C170_CHLF, C170_CHRF
06-10951-06	Alu Electrolytic Capacitor	CD263(X),1uF,50V,±20%,F2.5	C182_PSL, C182_PSR, C184_PSL, C184_PSR
06-22011-10	ALU Electrolytic Capacitor	22uF, 16V, ±20%, 105℃	C179_PSL, C179_PSR
06-47061-01	ALU Electrolytic Capacitor	47uF, 63V, ±20%, 85℃	C63, C123
06-33121-06	Alu Electrolytic Capacitor	CD289,330uF,25V,±20%	C138, C153
06-33160-07	Alu Electrolytic Capacitor	PLF0J331MDL4TD,330uF,6.3V,±20%,105℃,F2.5	C126
06-10111-21	Alu Electrolytic Capacitor	CD284,100uF,10V,±20%,105℃,F2.5	C47
06-10111-22	Alu Electrolytic Capacitor	CD289,100uF,16V,±20%,105℃,F2.5	C55, C151
06-10111-05	ALU Electrolytic Capacitor	100uF, 16V, ±20%, 85℃	C62
06-10211-13	Electrolytic Capacitor	CD284,1000uF,10V,±20%,105℃,F3.5	C59
06-47281-04	ALU Electrolytic Capacitor	4700uF, 80V, ±20%, 85℃, 两只脚	C28, C30, C40, C41
	INDUCTOR		
22-01626-00	Transformer	T16*9*5-4TS	L14_CHLF, L14_CHRF
08-01509-00	Inductor	5uH, ±30%, T44-2 (Ø0.5mm的线绕制26圈)	L10_CHLF, L10_CHRF
J19-00442-00	Ferrite Ring	T44-2	L10_CHLF, L10_CHRF
08-01140-00	Inductor	14.5uH, ±20%, T106-2-33TS	L13_CHLF, L13_CHRF
J19-01062-00	Ferrite Ring	T106-2	L13_CHLF, L13_CHRF
08-01330-00	Inductor	744132,33uH	L11
	CONNECTORS		
21-10750-00	Link(φ1.0)	L=7.5mm	J10, J11
12-02202-15	RELAY POWER	HFD31/5 5VDC	RL1
12-03101-16	RELAY POWER	HF115F/012-2HS4A	RL2, RL3
A07-70022-19	SPST Switch	ST-22 90℃ W TYPE 镀锡	J8

C390DD BOM

01-39010-00	PSU A BOARD		
	PCB		
A16-39010-23	PSU -A		
	DIODES		
33-20007-00	Rectifier Diode	M7A, 1A 1000V	D102 D103 D104
33-40321-00	Switch Diode	BAS321	D107 D108 D109 D110 D111
33-44148-17	Switch Diode	1N4148W-NR	D100 D101 D116 D117 D118 D119
33-11200-11	Zener Diode SMD	12V/0.5W	DW102
33-17509-10	Zener Diode	7.5V, 0.5W	DW100 DW101
33-14709-07	Zener Diode	MM3Z4V7T1G, 4.7V 0.2W ±5%	DW103
33-30062-00	BRIDGE RECTIFIER	B6S, 0.8A 600V	BR100
33-40054-02	Schottky Rectifier Diode	BAT54J	D120
	TRANSISTOR		
31-00846-02	transistor	BC846BW	Q109
31-00114-05	Digital transistor	DTC114EKA	Q102
31-80716-00	transistor	BC807-16	Q103
31-80725-00	transistor	BC807-25	Q107 Q108
31-00856-03	Transistor	BC856BW SOT323	Q110
	IC		
03-01150-01	PFC control IC	IR1150ISTRPBF	IC100
03-06477-02	IC DRIVER	ISL6744AABZ	IC101
03-61562-01	Photo Transistor	SFH6156-2T	OP100 OP101 OP102 OP103 OP104
03-00017-01	Automatic X Cap Discharge IC	CAP017DG-TL	IC102
	Capacitor		
26-10151-01	Chip capacitor	0805, 100PF, 50V, NPO	C100 C101 C140 C143
26-18151-01	Chip capacitor	0805, 180PF, 50V, NPO	C141
26-20151-01	Chip capacitor	0805, 200PF, 50V, NPO	C135 C142
26-10251-11	Chip capacitor	0805, 1nF, 50V, NPO	C132
26-15251-11	Chip capacitor	0805, 1.5nF, 50V, NPO	C134
26-10351-11	Chip capacitor	0805, 10nF, 50V, NPO	C102, C103, C146
26-10451-11	Chip capacitor	0805, 100nF, 50V, X7R	C144, C147
26-22421-01	Chip capacitor	0805, 220nF, 25V, X7R	C119
26-33421-01	Chip capacitor	0805, 330nF, 25V, X7R	C133
26-10521-01	Chip capacitor	0805, 1UF, 25V, X7R	C136 C137
26-10611-02	Chip capacitor	1206, 10uF, 16V, X5R	C138 C139
26-33122-02	Chip capacitor	1206, 330pF, 200V, NPO	C122 C123
26-10422-02	Chip capacitor	1206, 100nF, 200V, X7R	C124 C125
26-10352-02	Chip capacitor	1206, 10nF, 500V, X7R	C130 C131
26-10313-02	Chip capacitor	1206, 10nF, 1000V, X7R	C106 C107 C108 C109 C110 C111
26-33052-02	Chip capacitor	1206, 33pF, 500V, NPO	C113 C114
	RESISTOR		
07-91009-01	Chip resistor	0805, 10R, 1%	R106 R145 R166
07-92209-01	Chip resistor	0805, 22R, 1%	R142 R143
07-93309-01	Chip resistor	0805, 33R, 1%	R139 R140 R141
07-91000-01	Chip resistor	0805, 100R, 1%	R151
07-92200-01	Chip resistor	0805, 220R, 1%	R100 R101 R102 R103 R160
07-93300-01	Chip resistor	0805, 330R, 1%	R107
07-96800-01	Chip resistor	0805, 680R, 1%	R104
07-91001-01	Chip resistor	1KQ,0805,1/8W,±1%,RC0805FR-071KL	R162
07-92001-01	Chip resistor	2KQ,0805,1/8W,±1%,RC0805FR-072KL	R105, R167
07-94701-01	Chip Resistor	4.7KQ,0805,1/8W,±1%,RC0805FR-074K7L	R170
07-97501-01	Chip resistor	0805, 7.5K, 1%	R155
07-91002-01	Chip resistor	10KQ,0805,1/8W,±1%,RC0805FR-0710KL	R128, R144, R161, R168, R169
07-91802-01	Chip resistor	0805, 18K, 1%	R153 R154
07-93902-01	Chip resistor	0805, 39K, 1%	R138
07-96802-01	Chip resistor	0805, 68K, 1%	R159
07-98202-01	Chip resistor	0805, 82K, 1%	R152
07-92403-01	Chip resistor	0805, 240K, 1%	R131 R132 R133 R134 R135 R136
07-92703-01	Chip resistor	0805, 270K, 1%	R129 R130

C390DD BOM

07-92208-02	Chip resistor	1206, 2R2, 1%	R137
07-91009-02	Chip resistor	10Ω,1206,1/4W,±1%,RC1206FR-0710RL	R164 R165
07-92009-02	Chip resistor	20Ω,1206,1/4W,±1%,RC1206FR-0720RL	R146 R163
07-90221-02	Chip resistor	1206, 220R, 5% 0,25W	R147 R148
07-90471-02	Chip resistor	470R, 1206, 5%	R108 R114
07-90513-02	Chip resistor	51KΩ,1/4W,±5%,RC1206JR-0751KL	R109 R115
07-90154-02	Chip resistor	150KΩ,1206,1/4W,±5%,RC1206JR-07150KL	R120 R121
07-93307-16	Chip resistor	2512, 0R33, 1%, 2W	R156 R157 R158
07-96201-06	Chip resistor	2512, 6k2, 1%, 2W	R124 R125 R126 R127
	DIODES		
33-25406-00	diodes	1N5406RL	D105
33-23006-00	diodes	30ETH06PBF	D106
or 33-22906-00	diodes	DSEP 29-06A	D106
33-21620-00	Rectifier Diode	MUR1620	D112 D113 D114 D115
33-32542-00	BRIDGE RECTIFIER	TS25P05G, 25A/420VRMS	BR101
	TRANSISTOR		
31-02878-00	transistor	2SC2878	Q100 Q101
31-01850-03	N-Channel MOSFET	FDP18N50	Q104 Q105 Q106
	JC		
31-05064-00	THYRISTOR	2N5064	TSG100 TSG102
31-06402-00	THYRISTOR	2N6402	TSG101 TSG103
25-10542-00	Metallize Polyester	MMK22.5, 105K400D15L4	C115
25-10542-01	Miniaturized polypropylene film Cap	MKP21-400V-105J,1uF,400Vdc,±5%,W 26.5,H 20,T 11,P 22.5	C116 C117
25-68342-01	Miniaturized polypropylene film Cap	CBB21-400V-683K	C120 C121
25-10561-02	Metallized Polyester Film Capacitor	CL23B-63V-105J RA	C104 C105
A25-33422-00	Interfernece Suppression Cap	MKP62, 330nF, 275VAC, X2, ±10%	CX100
A25-22522-05	Interfernece Suppression Cap	MPX, 2.2uF, 275V, ±10%, PX225K3IE89H200DR	CX102
A25-10422-07	Interfernece Suppression Cap	MPX,0.1uF/275V,13mm*6mm,10%,Pitch=10mm	CX101
A05-22242-00	High Voltage Ceramic Capacitor	CT81-400VAC-08b-2E4-222M-YA	CY102
06-10051-02	Alu Electrolytic Capacitor	CD263(X), 10uF, 50V, ±20%	C112
06-22281-04	Alu Electrolytic Capacitor	2200uF, 80V, ±20%,105°C	C126 C127 C128 C129
06-22142-04	Alu Electrolytic Capacitor	CD29C,220uF,450V,±20%,105°C	C118 C145
	RESISTOR		
07-40100-10	Ceramic Resistor	10Ω,10W,±5%,Pitch=5mm	R112 R113 R118 R119
07-30151-12	Metal Oxide film Resistor	RY21, 150Ω, 2W, ±5%	R111 R117
07-30132-03	Metal Oxide film Resistor	RY21, 1.3KΩ, 3W, ±5%	R110 R116
07-30104-06	Metal Oxide film Resistor	RY21, 100KΩ, 2W, ±5%,Pitch=5mm 立式	R123
A07-72381-00	NTC	SG64, NTC SG64/265VAC	NTC100
A07-70471-01	TVS	HEL-14D471K	ZV100
	INDUCTOR		
22-00100-03	INDUCTOR	I32L10UH, 10uH ±10%	L103
22-00025-09	common mode line chokes	LE-T25M, ≥8mH	L101
08-05541-00	common mode line chokes	HJ-I22-PFC-L,540uH	L102
A22-04215-00	Transformer	HJ-C390EER4215	T102
22-00013-01	Transformer	TS-T13B	T100
22-01050-00	Current	CS1050L	T101
	RELAY		
A12-01101-00	POWER RELAY	JZC-36F 005-HSLT	K100 K101
or A12-03101-11	POWER RELAY	STD-S-105-LMR2, 5Vac TV-5	K100 K101

C390DD BOM

	CONNECTOR		
13-22502-14	Jumper Cap	2Pin CNT-MJ254-02-O	CON100 CON102
13-12502-19	Connector	2Pin, CNT-M254-1*2-GS-5.6/3-N	CON100 CON102
13-22502-00	Connector	XHB 2.54A-2A	J103
13-22505-00	Connector	XHB 2.54A-5A	J102
13-23903-01	Connector	VH 3.96A-3A	J100
84-006001-0	Cable Tie	YJ-163	Ties to L102
01-39011-00	PSU B BOARD		
	PCB		
A16-39011-21	PSU-B		
	DIODES		
33-20007-00	Diode	M7A	D202
33-20120-01	DIODE SMD	MURS120T3G	D200 D210
33-20036-00	Schottky Rectifier Diode	SS36B	D209
33-30062-00	BRIDGE RECTIFIER	B6S, 0.8A 600V	D207
33-11800-30	Zener Diode	18V, 3W, ±5%, SMB	DW200, DW201
	IC		
03-00431-11	Regulator	TL431BCDBZTG4	IC201 IC202
03-61562-01	Photo Transistor	SFH6156-2T	OP200 OP202 OP203
A03-00817-03	Photo Coupler	PC817X2NIP	OP201
	Capacitor		
26-10151-01	Chip capacitor	0805, 100PF, 50V, NPO	C207 C208
26-10451-11	Chip capacitor	0805, 100nF, 50V, X7R	C201 C202 C203 C214 C215 C216 C224 C225
26-22451-11	Ceramic Chip Capacitor	220nK,50V,0805,X7R	C218
26-10212-02	SMT Capacitor	1nF, 100V, X7R, ±10%	C209
	RESISTOR		
07-96808-01	Chip resistor	6.8Ω, 0805, 1/8W,1%	R217
07-91009-01	Chip resistor	0805, 10R, 1%	R218
07-91000-01	Chip resistor	0805, 100R, 1%	R212
07-93300-01	Chip resistor	330Ω,0805,1/8W,±1%,RC0805FR-07330RL	R207, R219
07-91001-01	Chip resistor	0805, 1K, 1%	R202 R203 R204 R206
07-92201-01	Chip resistor	0805, 2.2K, 1%	R223 R226 R227
07-93001-01	Chip resistor	0805, 3K, 1%	R222
07-97501-01	Chip resistor	0805, 7.5K, 1%	R216
07-91002-01	Chip resistor	0805, 10K, 1%	R200 R201
07-91202-01	Chip resistor	0805, 12K, 1%	R221
07-92202-01	Chip resistor	0805, 22K, 1%	R224 R225
07-95602-01	Chip resistor	56KΩ,0805,1/8W,±1%,RC0805FR-0756KL	R220
07-90101-02	Chip Resistor	100Ω,1206,1/4W,±5%	R210 R211
07-90121-02	Chip Resistor	120Ω,1206,1/4W,±5%	R208
07-90684-02	Chip resistor	1206, 680K, 5%	R213 R214 R215
	DIODES		
33-24006-00	Rectifier Diode	UF4006	D204 D205 D206
33-26200-00	TVS	P6KE-200A	D208
33-21620-00	Rectifier Diode	MUR1620	D201
33-30682-00	BRIDGE RECTIFIER	GUB608	D203
	TRANSISTOR		
31-00647-01	Transistor	2SB647-D	Q200
	IC		
03-00246-00	Power control IC	TOP246Y	IC200
03-00274-00	Power control IC	TNY274PN	IC203
03-07815-08	Voltage Regulators	KA78R15CTU	U200
	Capacitor		
25-10342-00	Metallized Polyester Film Capacitor	CL23B-400V-103K RA	C206
A05-22242-00	High Voltage Ceramic Capacitor	CT81-400VAC-08b-2E4-222M-YA	CY200 CY201

C390DD BOM

06-47042-01	Alu Electrolytic Capacitor	CD263,47uF,400V,±20%,105℃	C212
06-10042-00	Alu Electrolytic Capacitor	CD11H, 10uF, 400V, ±20%	C220
06-10051-02	Alu Electrolytic Capacitor	CD263, 10uF, 50V, ±20%, Pitch=2.5mm	C217 C223
06-47021-02	Alu Electrolytic Capacitor	CD263(X), 47uF, 25V, ±20%	C213
06-47051-06	Alu Electrolytic Capacitor	CD263,47uF,50V,±20%,6.3×11,F2.5	C219
06-10211-05	Alu Electrolytic Capacitor	CD263X,1000uF,10V,±20%,105℃,F5.0	C221 C222
06-10221-01	Alu Electrolytic Capacitor	CD263(X), 1000uF, 25V, ±20%	C210 C211
06-10121-11	Alu Electrolytic Capacitor	100uF, 25V, ±20%,105℃	C204 C205
	RESISTOR		
07-30473-02	Metal Oxide film Resistor	47KΩ, 2W, ±5%	R205
07-70050-02	NTC	5D-11	TH200
	INDUCTOR		
19-35980-00	Inductor	FB F10 RHW 3.5*8.3*0.8-T, 长引线	L200
08-02100-07	INDUCTOR	10uH, 2.6A,744772100	L204
08-05220-01	INDUCTOR	22uf	L203
A22-00025-14	Transformer	HJ-C390EEL25	T200
A22-00016-13	Transformer	HJ-C390EE16	T201
	Relay		
12-01101-19	继电器	HF36F/012-HST(555), TV-5	K200
	SPK BOARD		
	PCB		
A16-39002-22	C390DD SPK PCB		
26-47122-02	Ceramic Chip Capacitor	470PJ,200V,1206,NPO	C932, C934, C936, C938, C940, C942, C944, C946, C948, C950, C952, C954, C956, C958, C960, C962, C964, C965, C966, C967, C968, C969, C970, C971, C972, C973, C974, C975, C976, C977, C978, C979
	INDUCTOR		
22-01626-00	Transformer	T16*9*5-4TS	L901, L902
	CONNECTOR		
32-26308-06	PCB Terminal	6.3-1, HS4-CI9120-B009V1-M032	J2, J4, J5, J6
69-230001-0	Leaf Spring	镀铜QBe2.0 T=0.2mm,表面钝化处理	
	01-39013-00		
	Bootload BOARD		
	PCB		
A16-39013-21	C390DD Bootload PCB		
	Capacitor		
26-10611-01	Ceramic Chip Capacitor	10uF,0805,10V,C0805C106M8PACTU/C2012X5R1 A106M	C902
26-10351-01	Ceramic Chip Capacitor	10nK,50V,0805,X7R	C901
	esistor		
07-91009-01	Chip Resistor	10Ω,0805,1/10W,±1%,RC0805FR-0710RL	R951
	Diode		
33-40352-01	Switch Diode	1SS352(TPH3,F),1SS355TE-17	D951,D952

C390DD BOM

02-39012-00	HDMI BOARD	SMT PCB	SMT
A16-39012-21	C390DD HDMI PCB	C390DD HDMI PCB	
		Resistor	
07-90000-00	Chip resistor	0Ω,0603,1/10W,±5%	R412, R414, R426, R427, R428, R445, R448
07-90100-00	Chip resistor	10Ω,0603,1/10W,±5%	R418, R419, R420, R423
07-90220-00	Chip Resistor	22Ω,0603,1/10W,±5%,RC0603JR-0722RL	R443, R444, R452, R453, R488
07-90330-00	Chip resistor	0603, 33R, 5%	R430, R431, R432, R433, R434, R438, R441, R442, R446, R447, R449, R450, R451, R462
07-90101-00	Chip Resistor	100Ω,0603,1/10W,±5%,RC0603JR-07100RL	R466, R468, R469, R470, R472, R473, R474, R475
07-94990-00	Chip Resistor	499Ω,0603,1/10W,±1%	R409
07-98870-00	Chip Resistor	887Ω,0603,1/10W,±1%	R465
07-91001-00	Chip resistor	1KΩ, ±1%	R401, R402, R410
07-90152-00	Chip Resistor	1.5KΩ,0603,1/10W,±5%,RC0603JR-071K5L	R435, R476, R477
07-91801-00	Chip resistor	1.8KΩ,0603,1/10W,±1%,RC0603FR-071K8L	R436, R437
07-92001-10	Chip resistor	2kΩ,0.5%,0603	R503, R504
07-90472-00	Chip resistor	4.7KΩ, ±5%	R415, R416, R417
07-98201-00	Chip resistor	8.2KΩ,0603,1/10W,±1%	R471
07-90103-00	Chip resistor	10KΩ, ±5%	R496, R497, R505, R508,R498, R500
07-92002-00	Chip resistor	20KΩ,0603,1/10W,±1%	R499
07-90273-00	Chip Resistor	27KΩ,0603,1/10W,±5%,RC0603JR-0727KL	R429
07-90473-00	Chip resistor	47KΩ, ±5%	R403, R404, R405, R411, R489, R507
07-94872-00	SMD Resistor	48K7Ω, 1/10W, 1%, 0603	R502
07-90271-01	Chip Resistor	270Ω,0805,1/8W,±5%,RC0805JR-07270RL	R461
07-91601-01	Chip Resistor	1.6KΩ,0805,1/8W,±1%,RC0805FR-071K6L	R460
07-95101-01	Chip Resistor	5.1KΩ,0805,1/8W,±1%,RC0805FR-075K1L	R463
07-90103-01	Chip Resistor	10KΩ,0805,1/8W,±5%,RC0805JR-0710KL	R459
07-95362-01	Chip Resistor	53.6KΩ,0805,1/8W,±1%,RC0805FR-0753K6L	R464
07-91103-01	Chip Resistor	110KΩ,0805,1/8W,±1%,RC0805FR-07110KL	R458
07-93323-01	Chip Resistor	332KΩ,0805,1/8W,±1%,RC0805FR-07332KL	R457
07-94998-08	Chip Resistor	4.99Ω,0402, 1/16W, ±1%,RC0402FR-074R99L	R424
07-94999-08	Chip Resistor	49.9Ω, 0402,1/16W, ±1%,RC0402FR-0749R9L	R421, R422
07-90473-10	Chip Resistor Network	47kΩ*4, ±5%	RP407, RP408
07-90330-10	Chip Resistor Network	33Ω *4, ±5%	RP405, RP406
07-00075-03	SHORT CIRCUIT PROTECTION	750MA	F401
		Capacitor	
26-10351-08	Chip capacitor	10nF,50V,0402,±10%,X7R,CC0402KRX7R9BB103	C459, C460, C461, C462, C463, C464, C465, C466, C467, C468, C469, C470, C471, C473, C474, C475, C478, C479, C505, C506, C507, C508, C509, C510, C511, C512
26-10421-08	Chip capacitor	0.1uF,25V,+80, -20%,0402,Y5V, C1005Y5V1E104ZT	C407, C408, C411, C412, C419, C420, C421, C422, C423, C424, C425, C426, C427, C428, C433, C434, C435, C436, C437, C438, C441, C442, C445, C446, C453, C454
26-27051-00	Ceramic Chip Capacitor	27pJ,50V,0603,NPO	C485
26-33051-00	Ceramic Chip Capacitor	33pJ,50V,0603,NPO	C401, C402
26-39151-00	Ceramic Chip Capacitor	390PJ,50V,0603,NPO	C484
26-15351-00	SMD Capacitor	15nF,50V,X7R,0603	C483
26-22351-00	Chip capacitor	22nK,50V,0603,X7R	C405, C406, C409, C414
26-10451-00	Ceramic Chip Capacitor	100nZ,50V,0603,Y5V	C429, C430, C431, C432, C455, C456, C457, C458, C525, C526, C527, C528, C487, C417, C443, C447, C448, C449, C450, C451, C472, C482
26-10521-00	Ceramic Chip Capacitor	1uFZ,25V,0603,Y5V	C403, C418
26-22521-01	Ceramic Chip Capacitor	2.2uF,±10%,25V,X5R,0805	C480
06-22011-08	SMD Alu Electrolytic Capacitor	22UF/16V	B405, B406
06-10121-08	Alu Electrolytic Capacitor	100uF, 25V, ±20%,CAE8X10	C481
06-22121-09	Alu Electrolytic Capacitor SMD	220uF,25V,±20%,105°C,8*10.2,EEE-FK1E221AP	C444
27-10011-03	Chip Tan capacitor	10uF, 10V,±10%,3216,T491B106K016AT	B407, B408, B409, B410, B411, B412, B413, B414, C452

C390DD BOM

33-20336-01	Schottky Rectifier Diode	SS36	D410, D412, D423
33-20054-03	Schottky Diode	BAT54	D422
		Inductor	
08-04221-01	Ferrite Bead SMD	220R @100Mhz, CBG201209U221	FB410, FB411, FB412, FB413, FB414, FB415, FB416, FB417, FB401, L401
08-04100-08	Power Inductor	10uH,MSS7341-103ML	L402
		Crystal	
04-12864-01	Crystal	28.63636MHZ CL=22pF ,FL=20PPM	Y403
		IC	
03-07623-01	HDMI Transceiver	ADV7623	U419
03-24256-12	MCU	PIC24FJ256GA106-I/PT(C390DD程序)	U415
03-24256-02	MCU	PIC24FJ256GA106-I/PT	U415
03-00524-03	ESD Protection IC	RClamp0524PA	U401, U402, U403, U404, U405, U406, U407, U408, U409, U410, U411, U412
03-01963-18	Regulator	TL1963A-18KTTR	U445
03-01963-33	Regulator	TL1963A-33KTTR	U444
03-54331-01	DC/DC CONVERTER	TPS54331D	U416
03-03825-33	Supervisory Circuit	TPS3825-33DBVT,SOT23-5	U414
03-01117-06	Linear Regulator	AMS1117-3.3	U413
03-00244-01	Octal Buffer	74LCX244WM/MC74LCX244DW/SN74LVC244ADW	U417
		CONNECTORS	
17-08119-04	HDMI SOCKET	HDMI-007	P401, P402, P403, P408
06-33160-01	Alu Electrolytic Capacitor	HCN,330uF,6.3V,±20%,105°C,F3.5, 8×11.5mm	B403, B404
06-10260-11	Alu Electrolytic Capacitor	HPE,1000uF,6.3V,±20%,105°C,F5.0	C486

AMP BOARD - COPPER SIDE

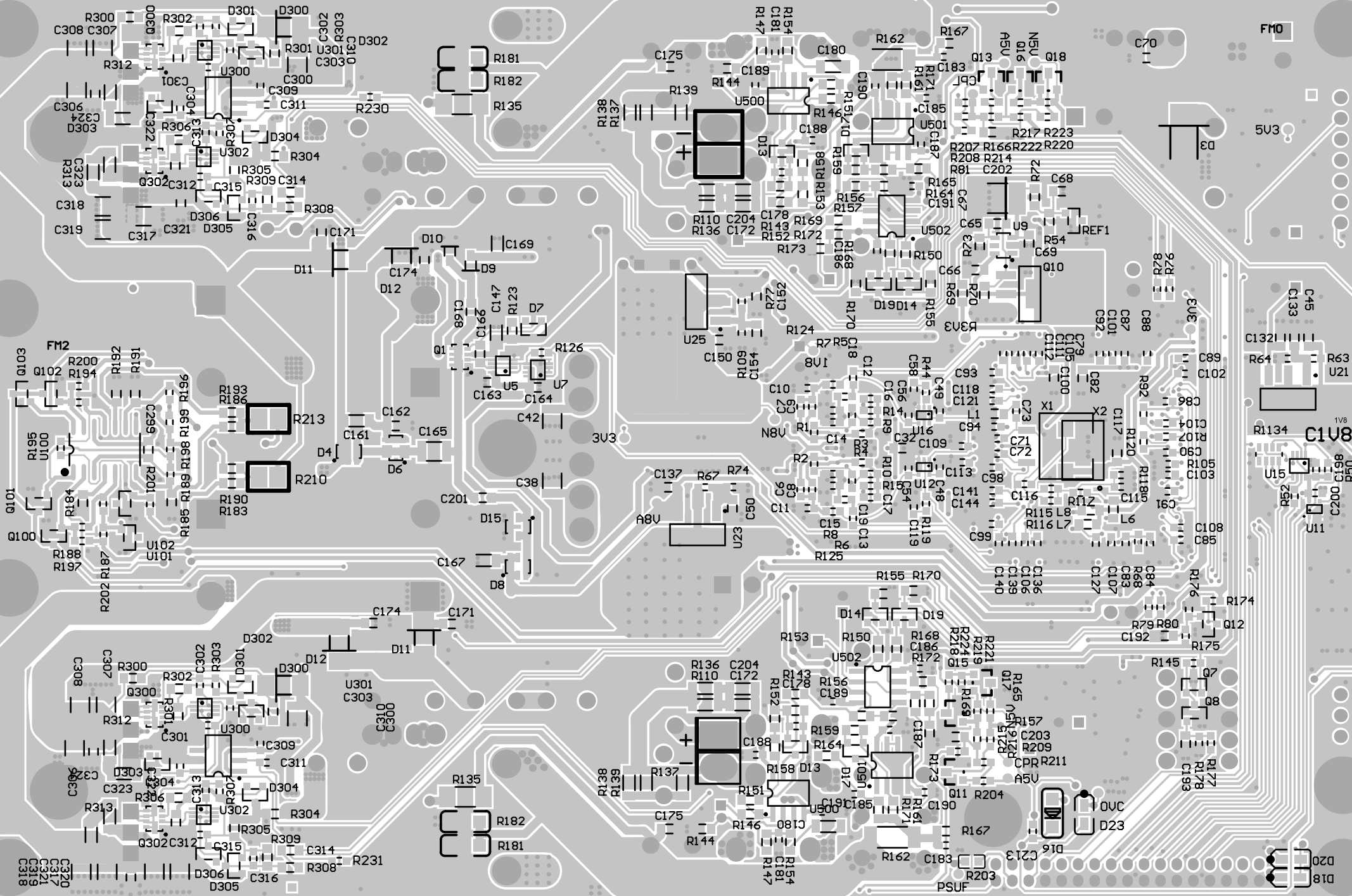

Copyright Diodes Incorporated 2011

AMP BOARD - COMPONENT SIDE

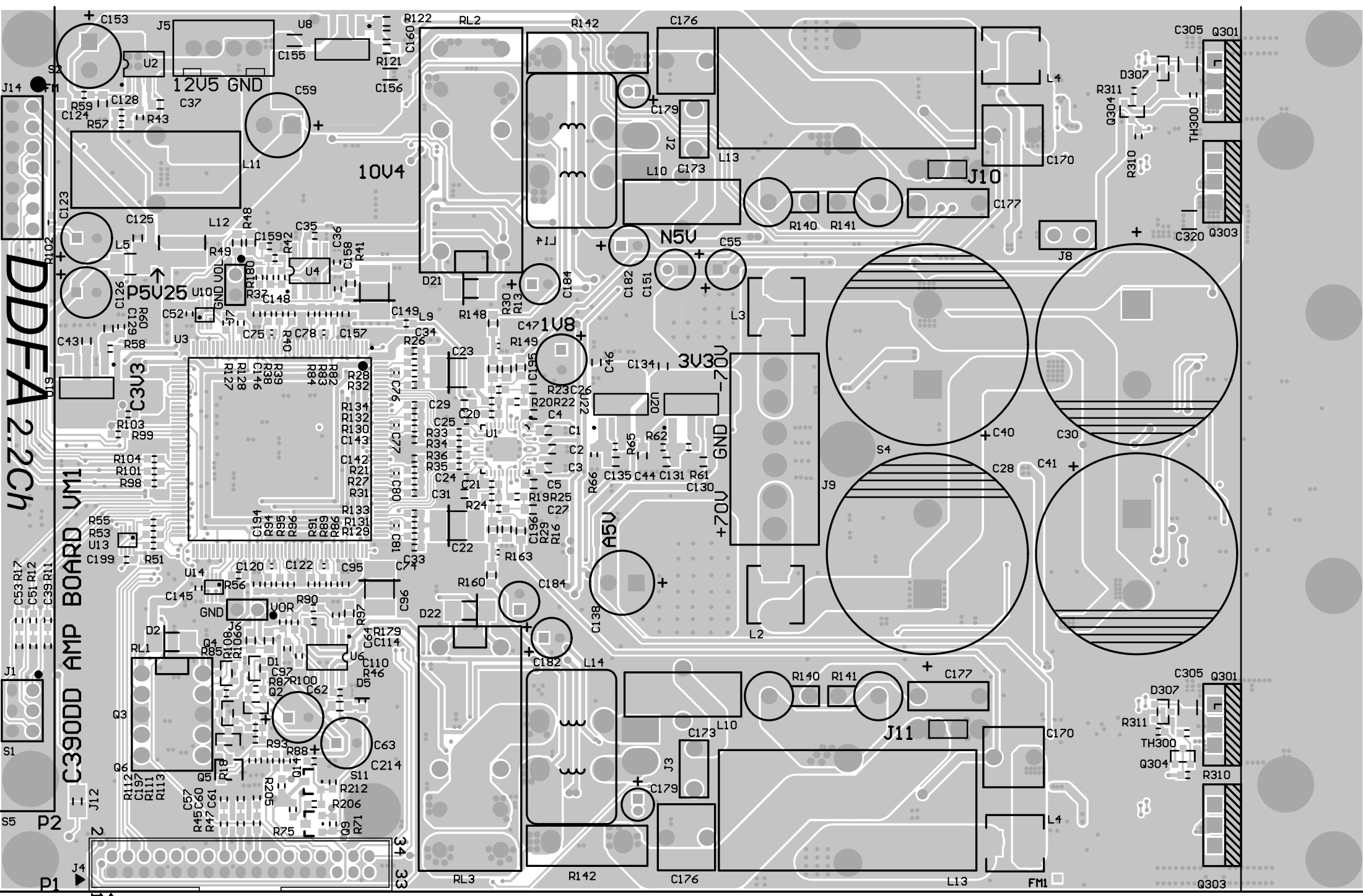

DDFA 2.2ch

C390D AMP BOARD VM1

P1
P2
J12
J1
S1
S5

C305 Q301
D307
R311
TH300
Q304
R310
Q303

Analog BOARD - COPPER SIDE

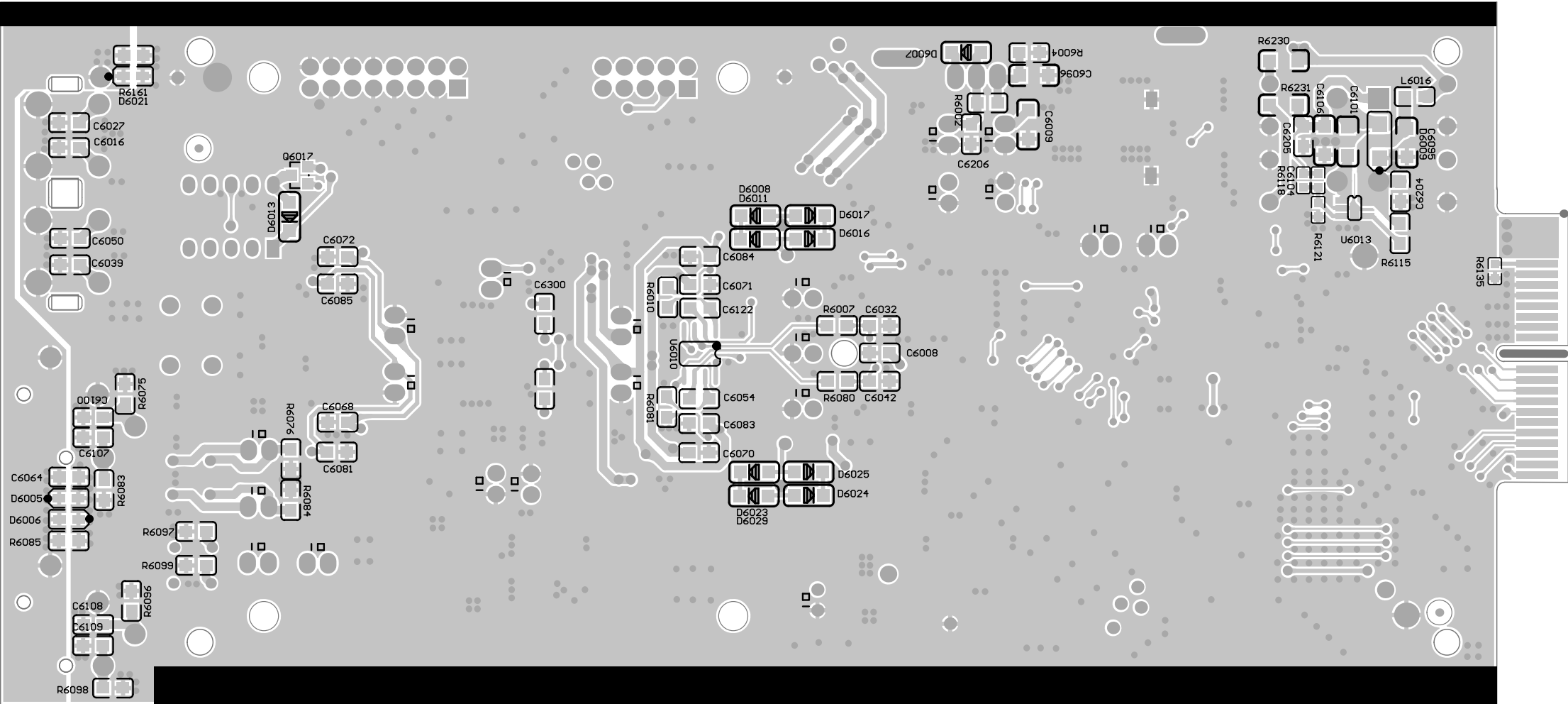

Analog BOARD - COMPONENT SIDE

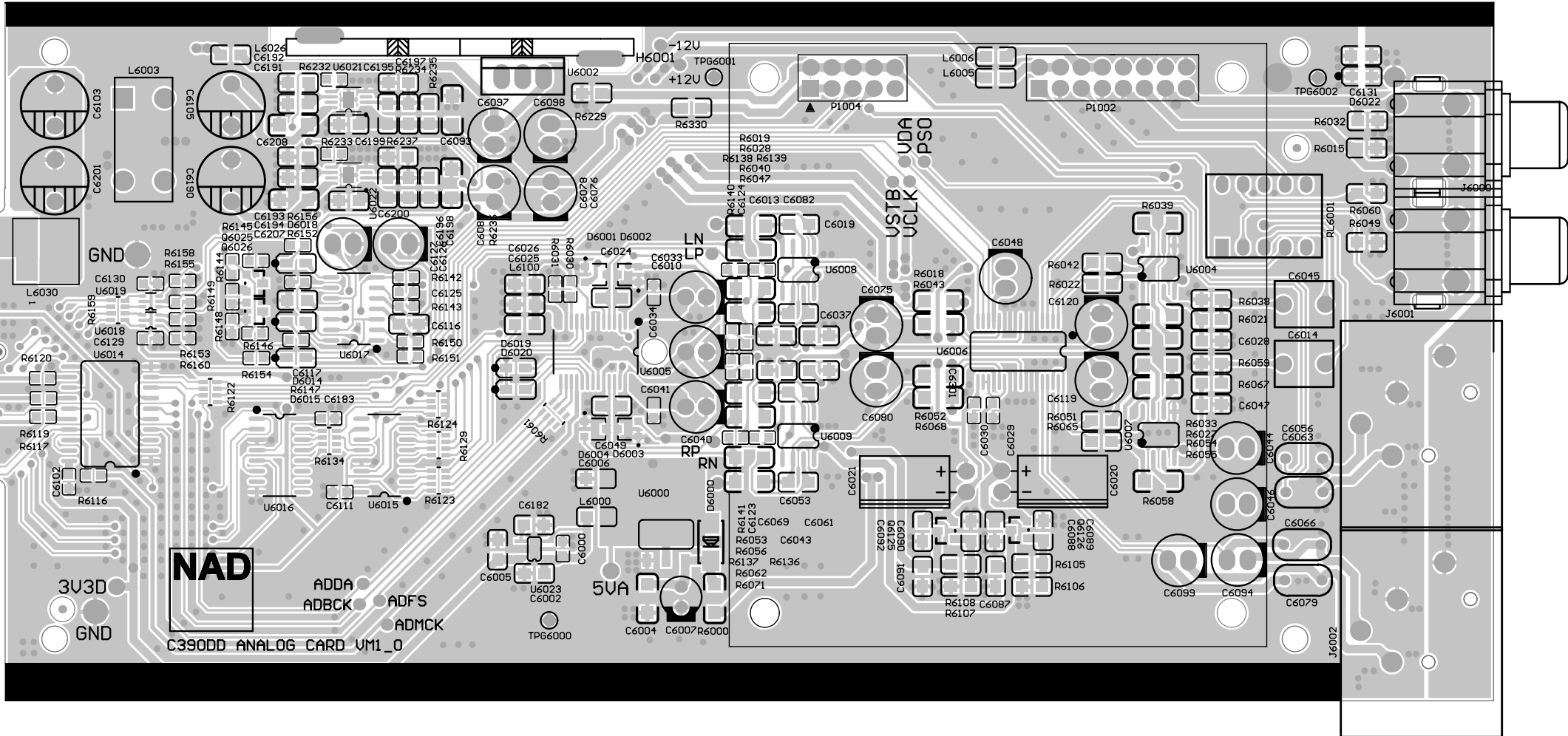

FPP BOARD - COPPER SIDE

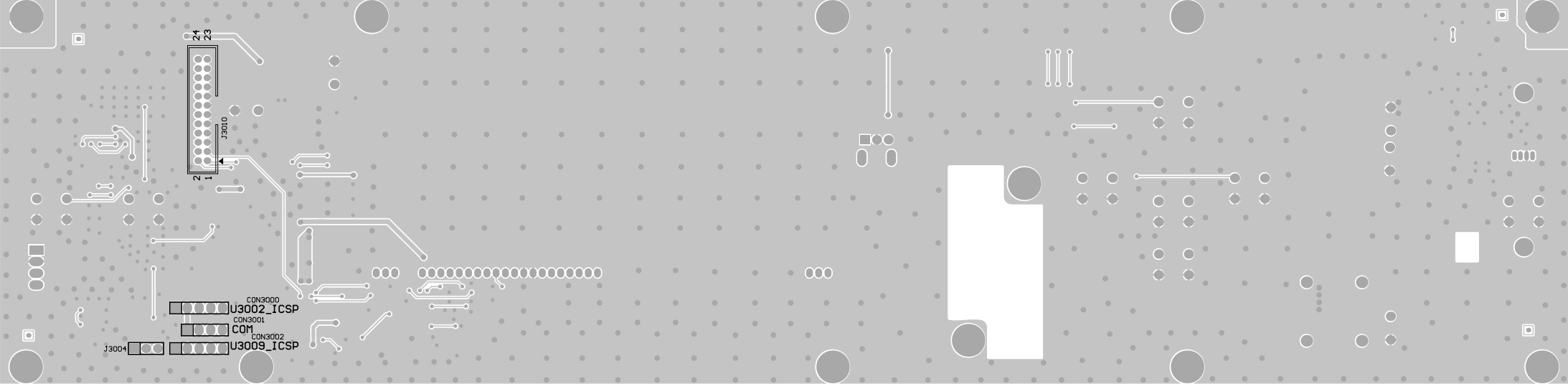

FPP BOARD - COMPONENT SIDE

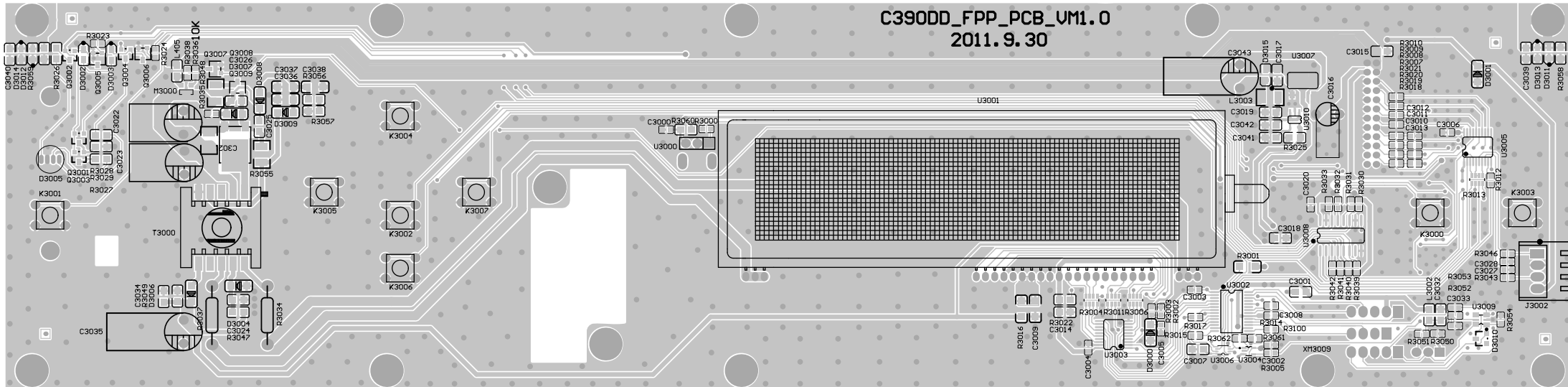

HDMI BOARD - COPPER SIDE

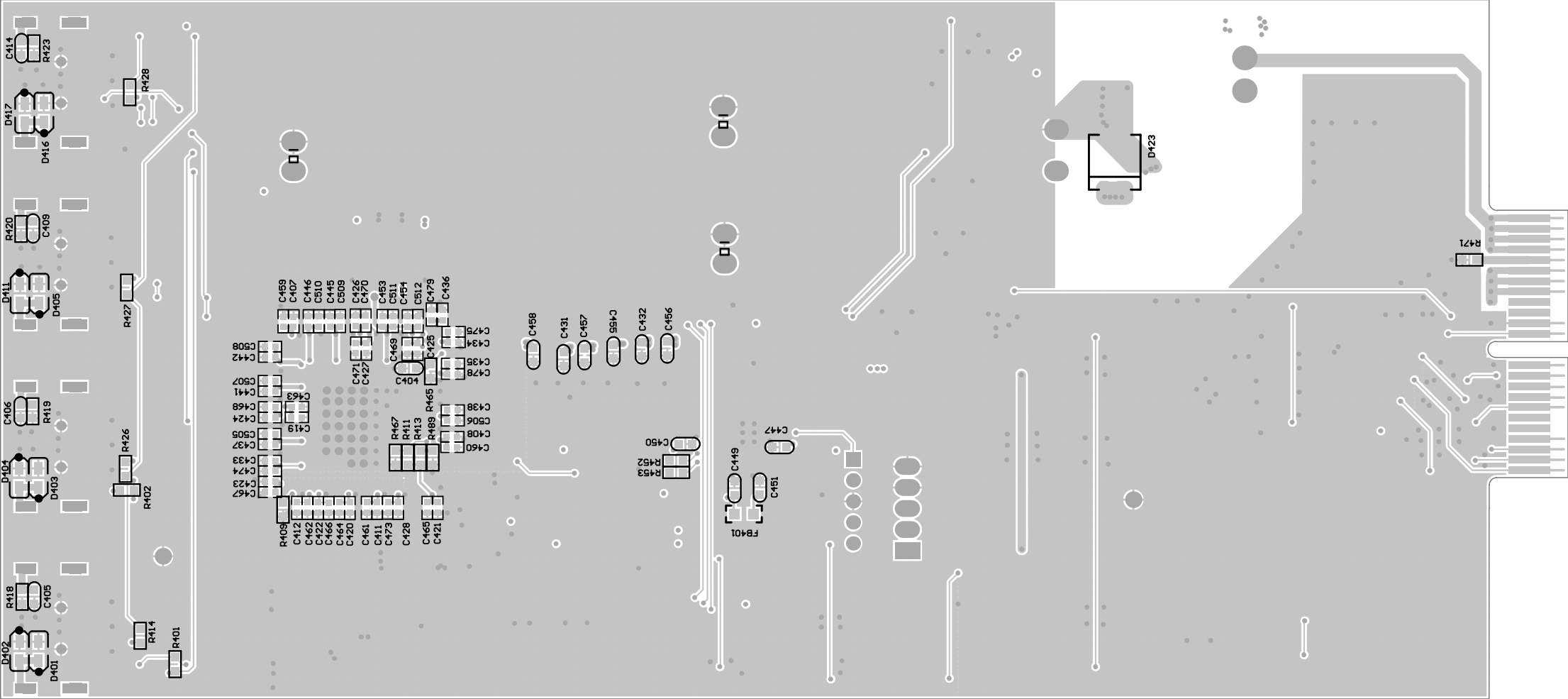

HDMI BOARD - COMPONENT SIDE

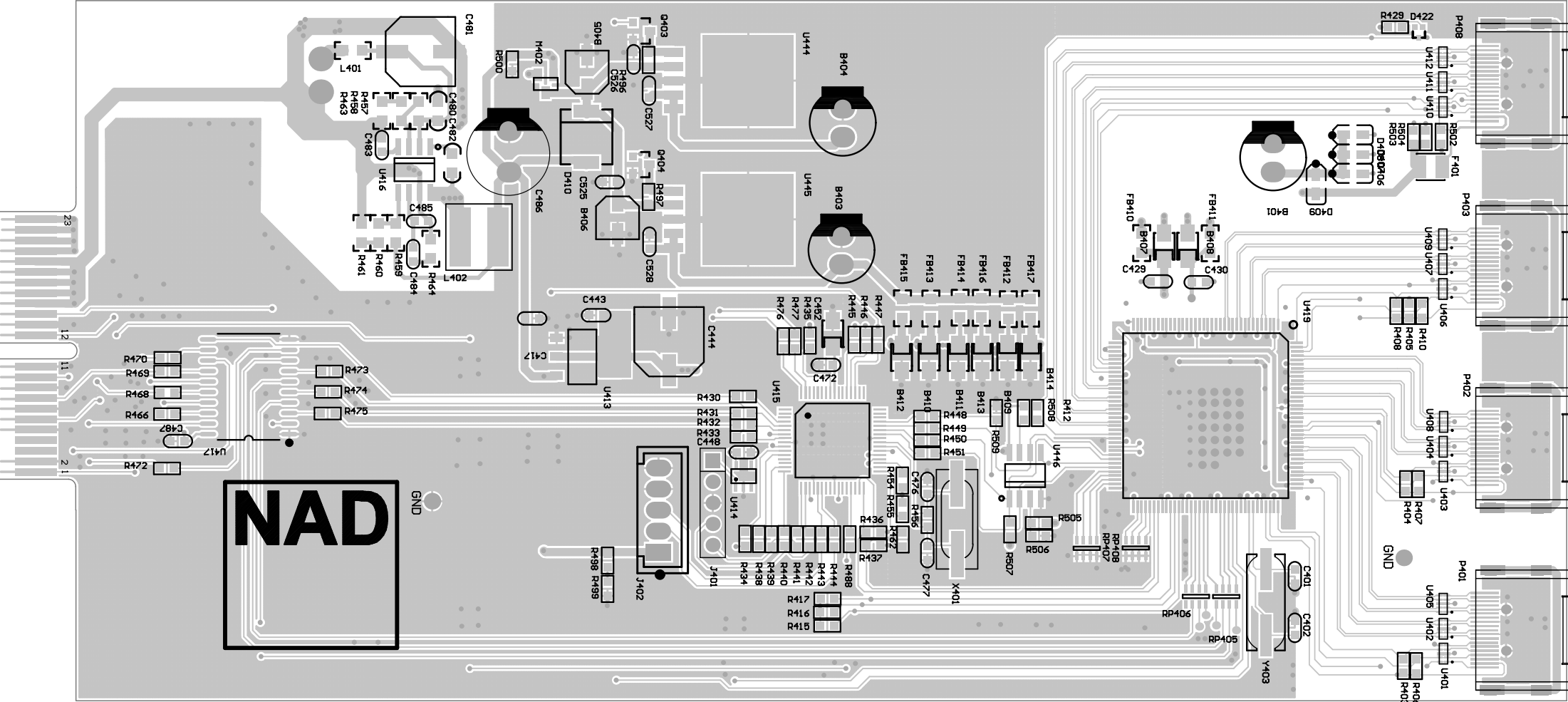

NAD

INT BOARD - COPPER SIDE

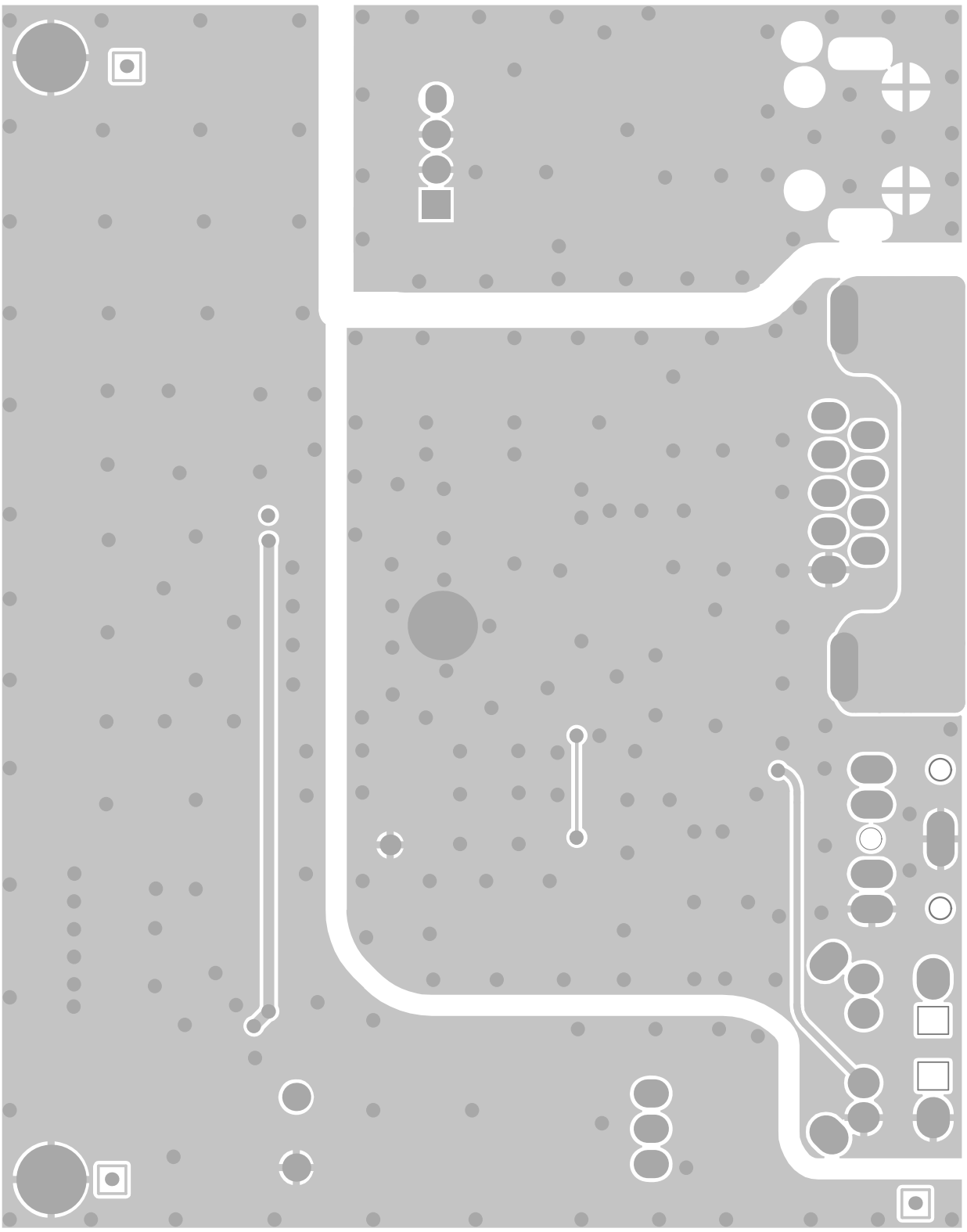

INT BOARD - COMPONENT SIDE

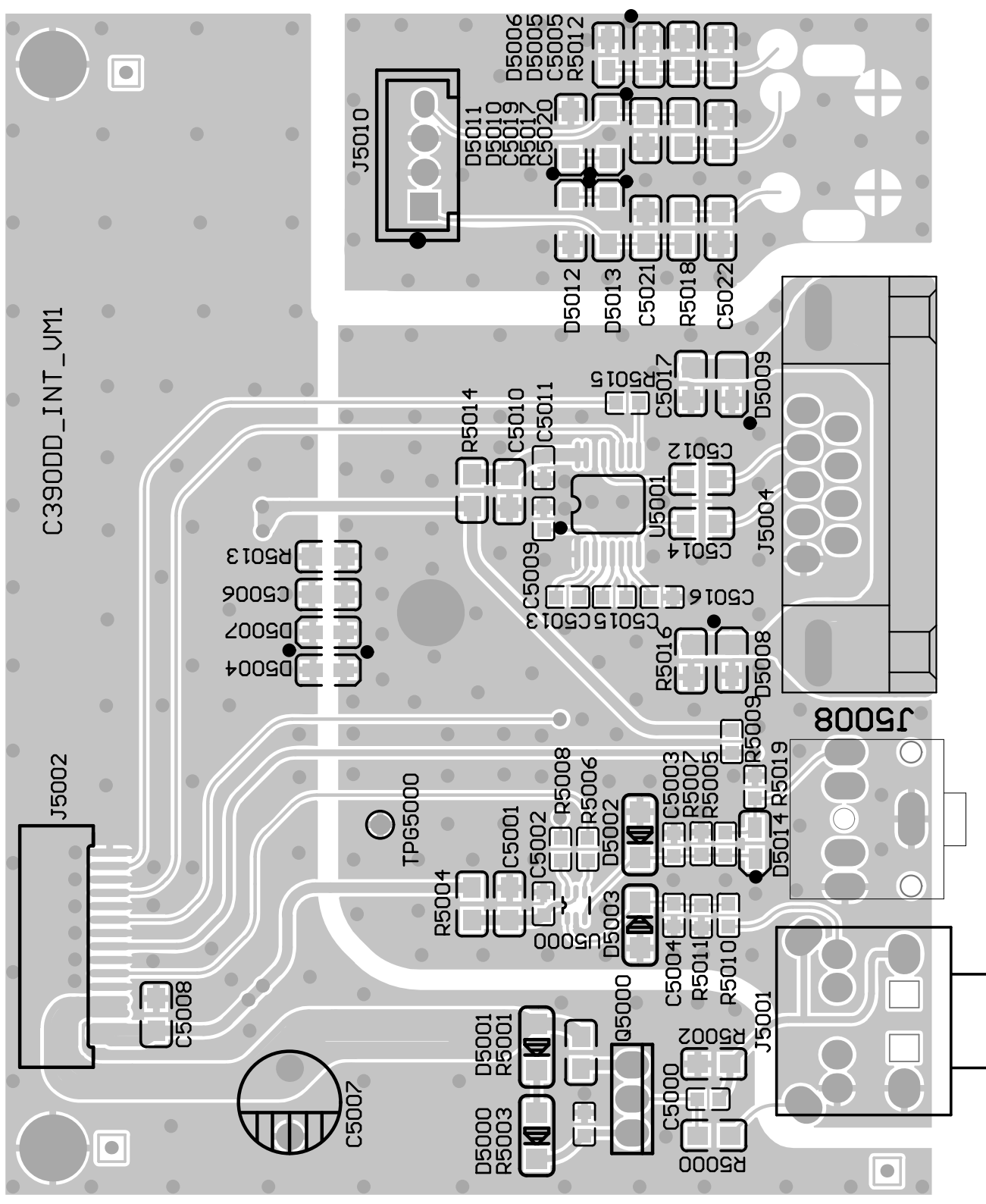

Main BOARD - COPPER SIDE

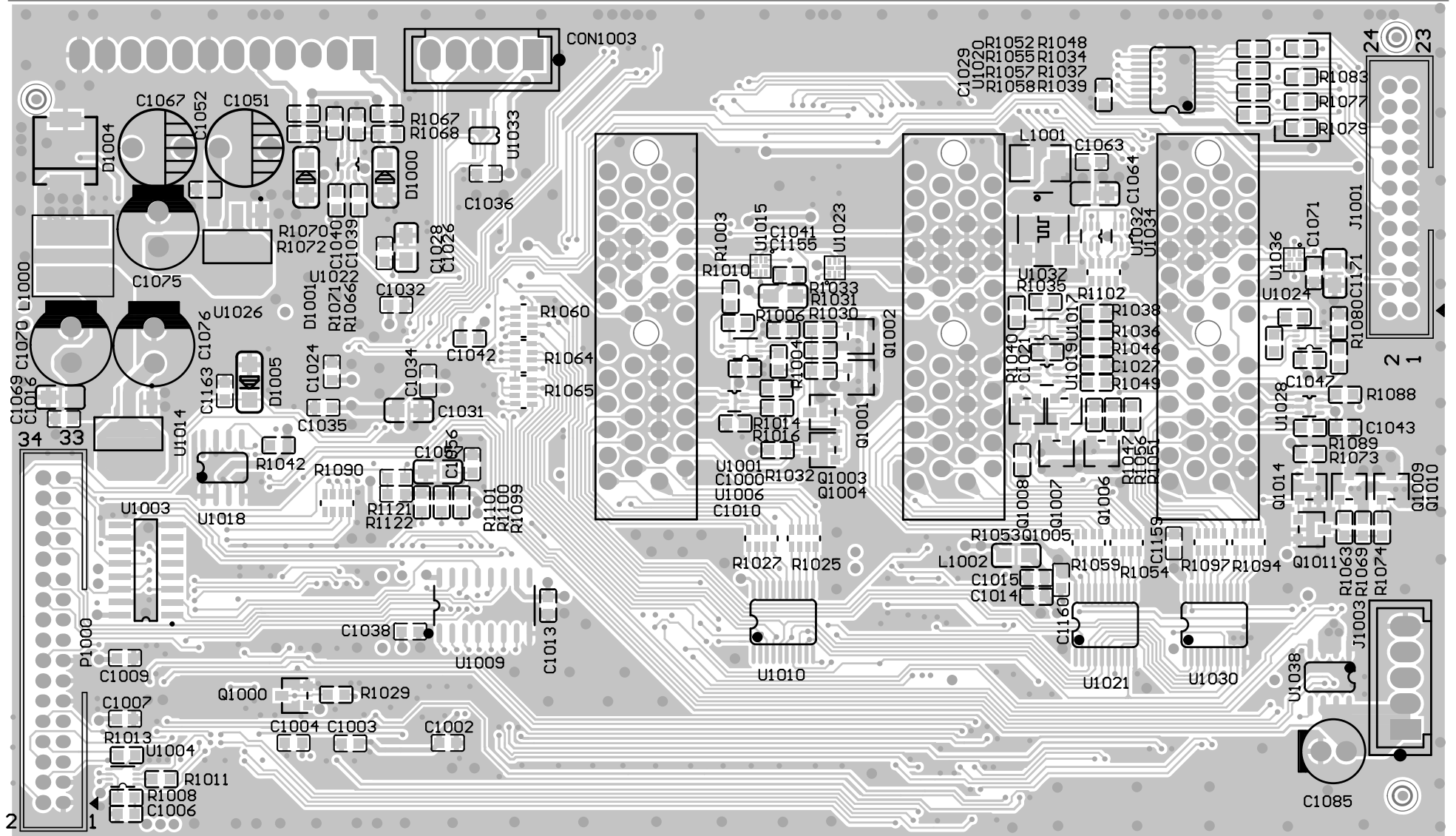

Phono BOARD - COPPER SIDE

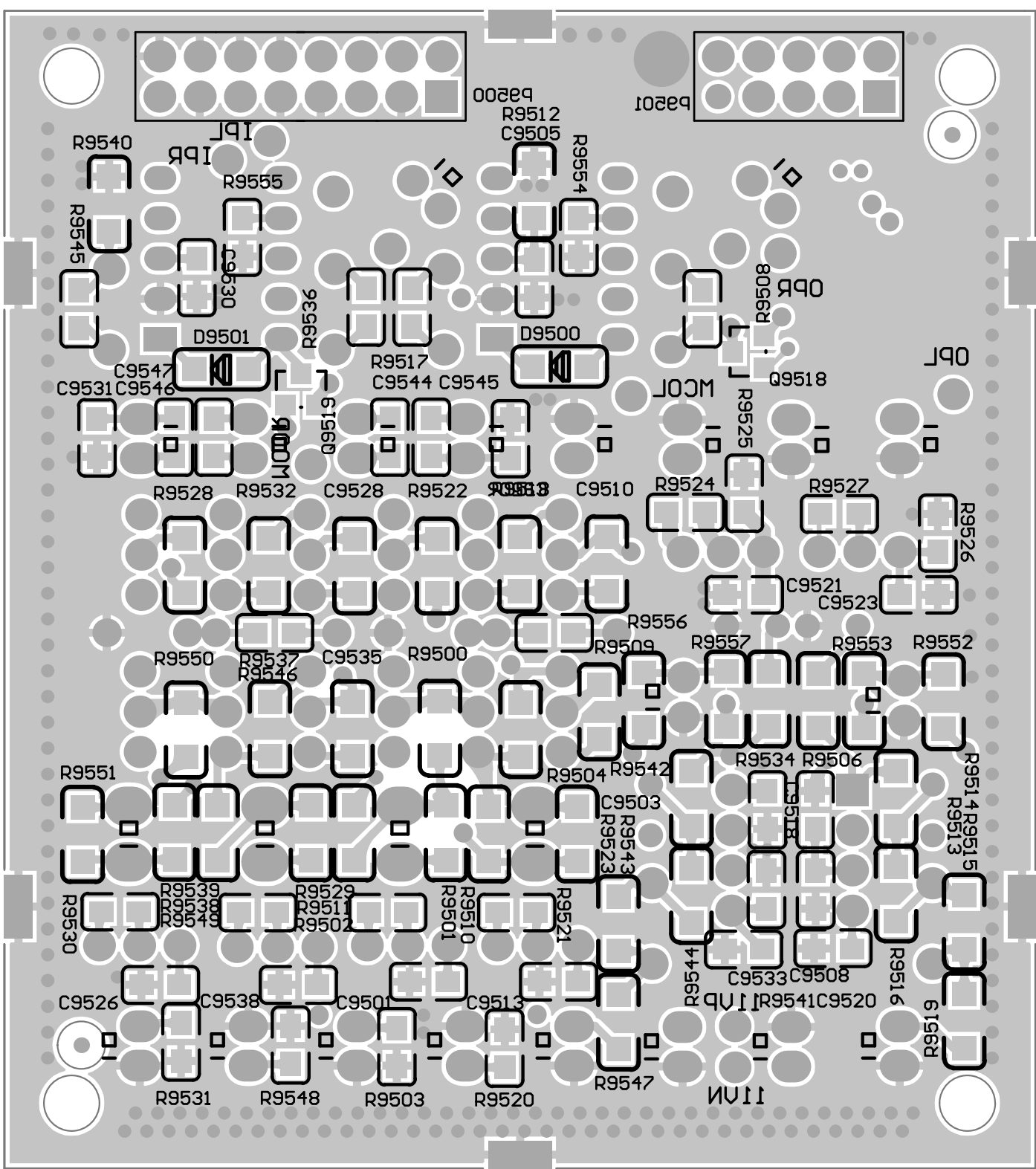

Phono BOARD
COMPONENT SIDE

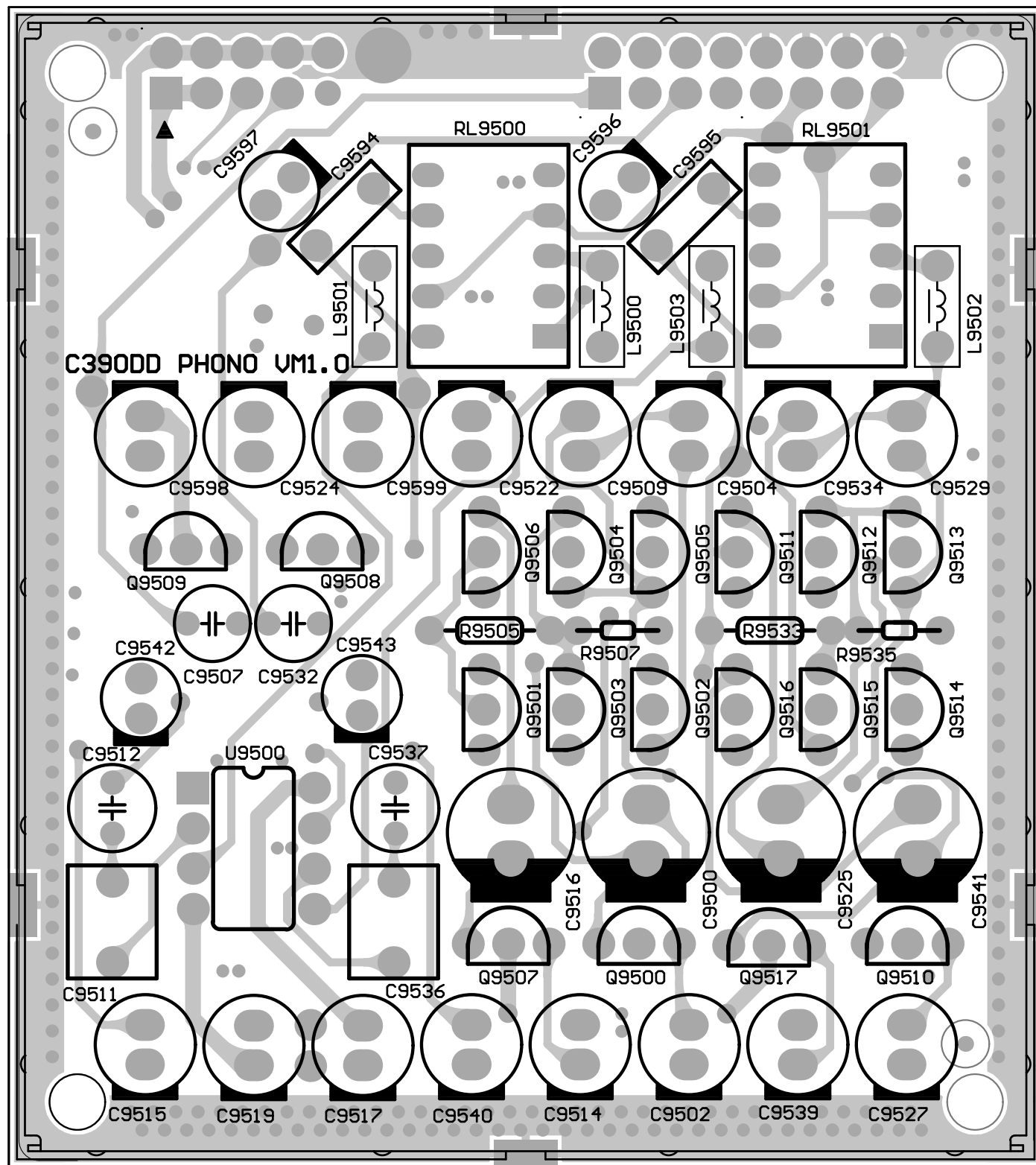

PSU-A BOARD - COPPER SIDE

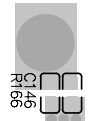
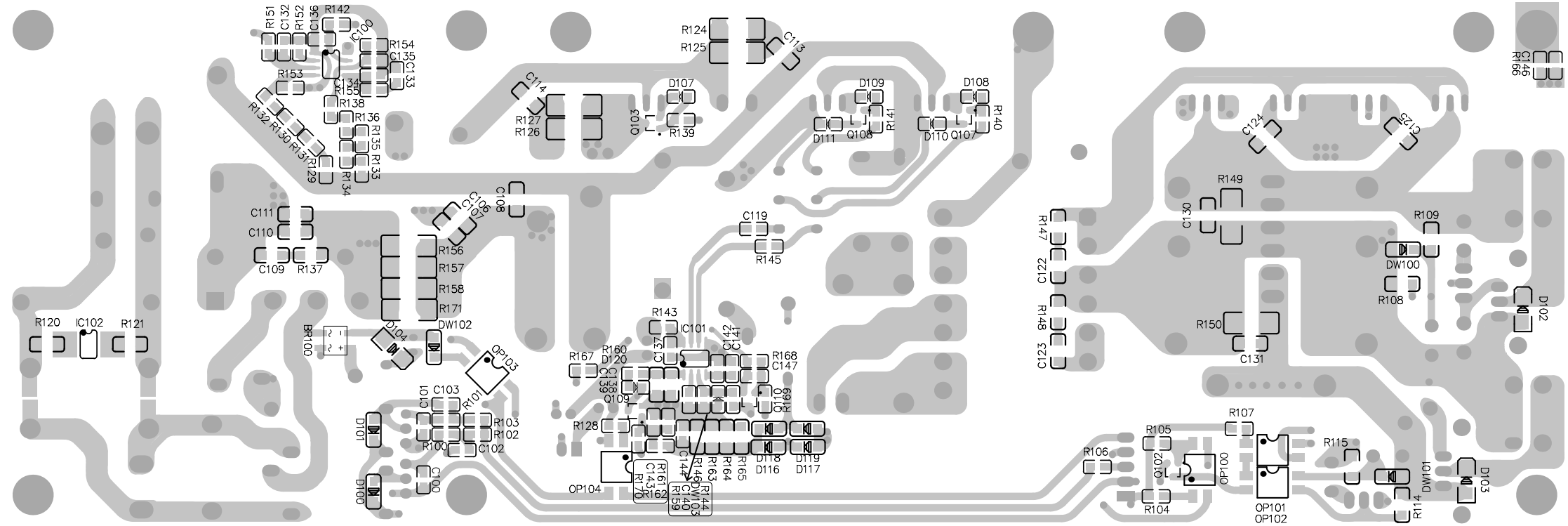

PSU-A BOARD - COMPONENT SIDE

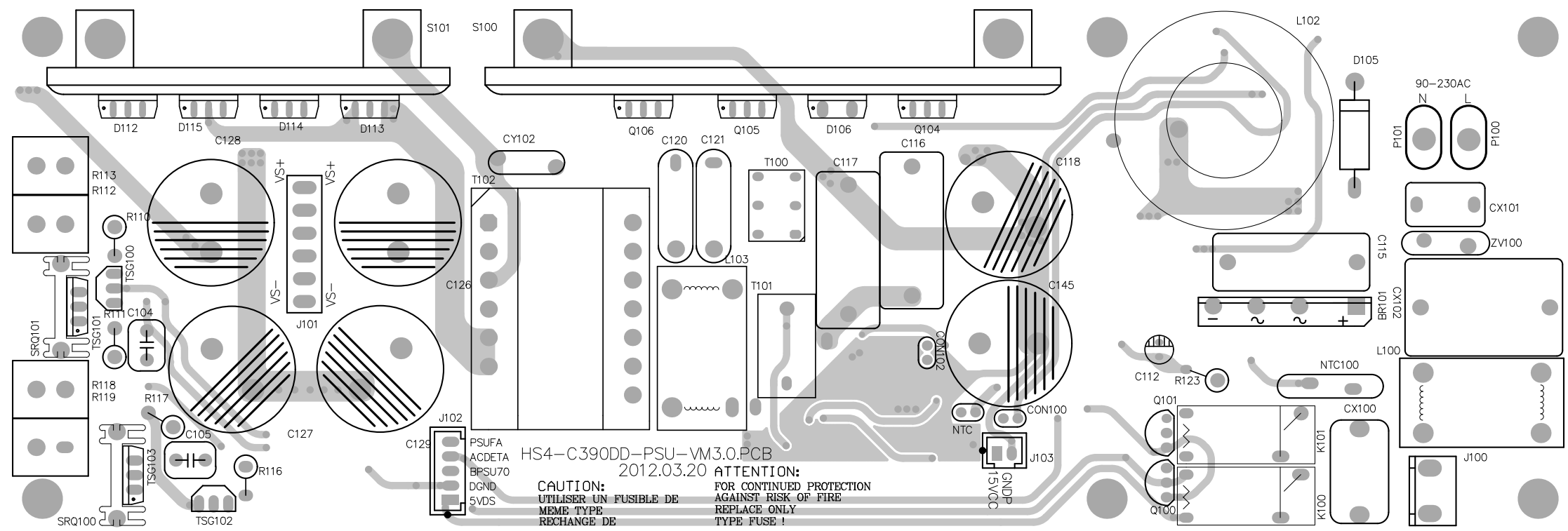

HS4-C390DD-PSU-VM3.0.PCB
2012.03.20

CAUTION:
UTILISER UN FUSIBLE DE
MEME TYPE
RECHANGER DE

ATTENTION:
FOR CONTINUED PROTECTION
AGAINST RISK OF FIRE
REPLACE ONLY
TYPE FUSE !

PSU-B BOARD
COPPER SIDE

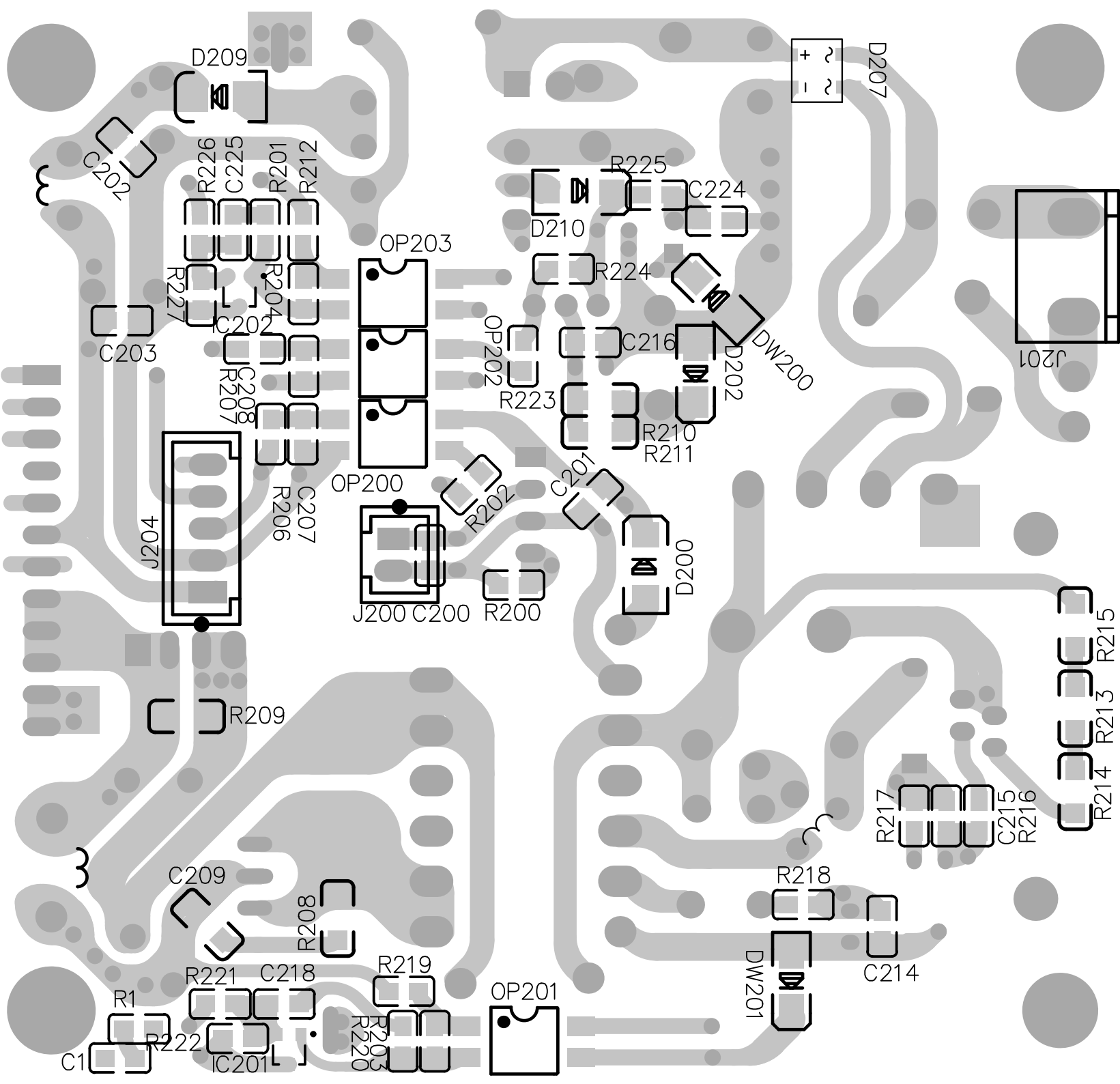

PSU-B BOARD
COMPONENT SIDE

AC90-230V
T3.15A/250V

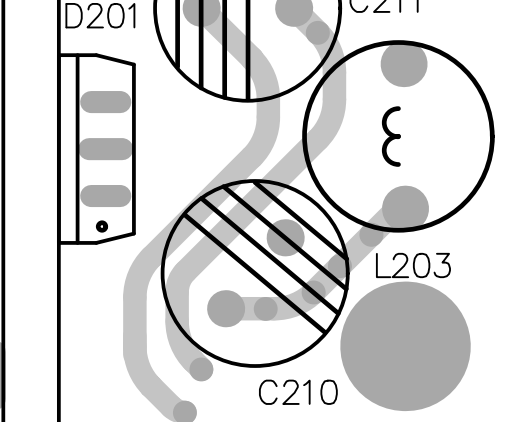
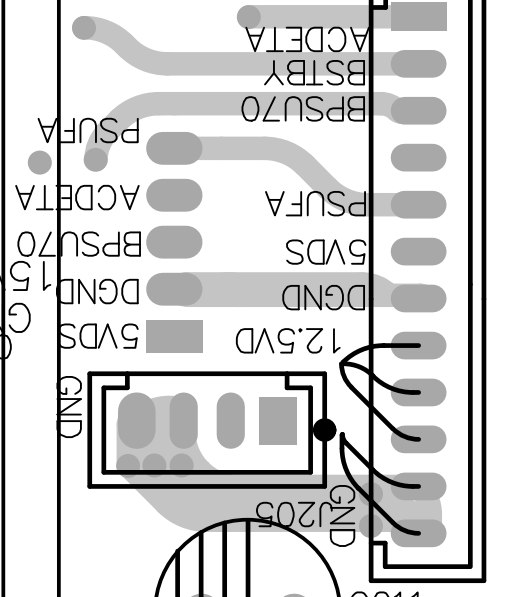
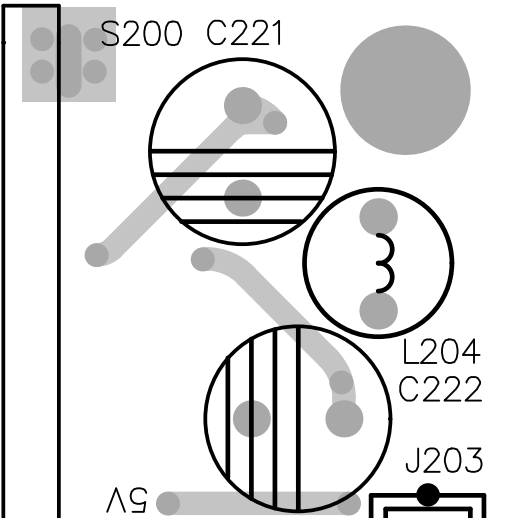
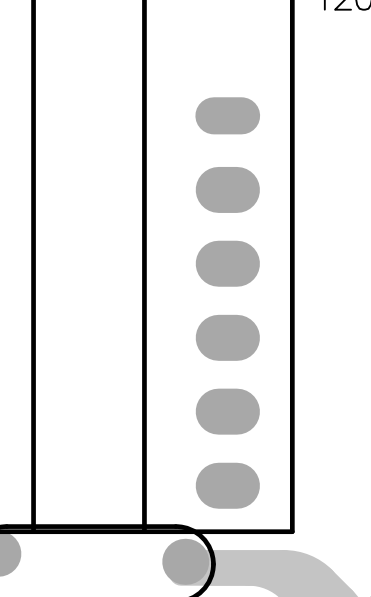
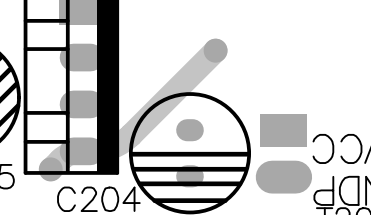
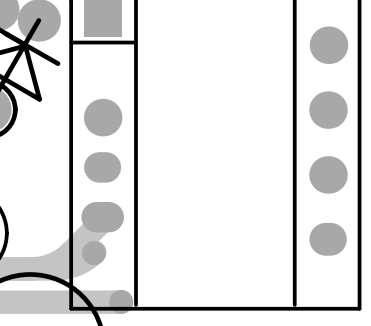
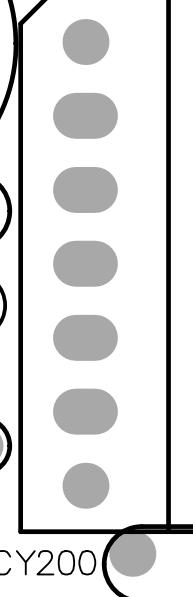
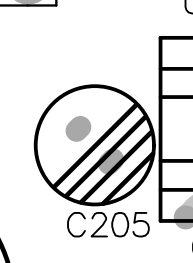
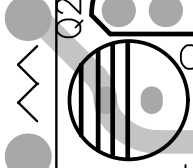
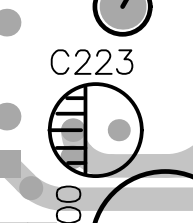
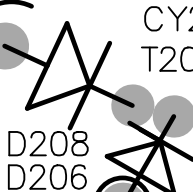
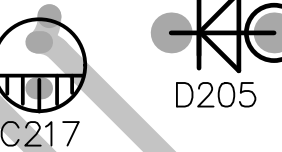
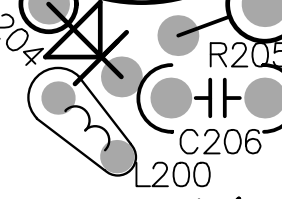
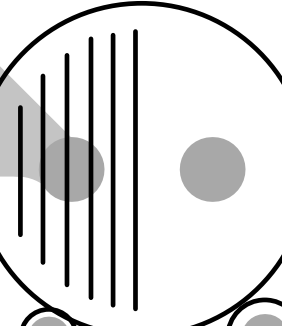
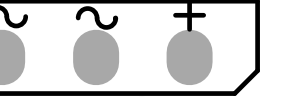
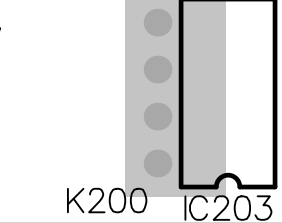
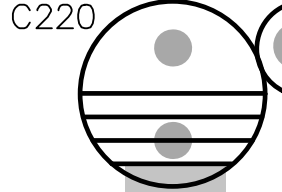
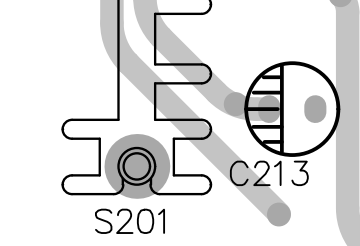
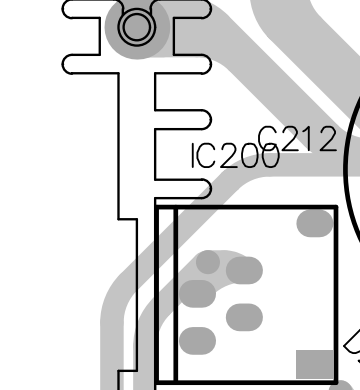
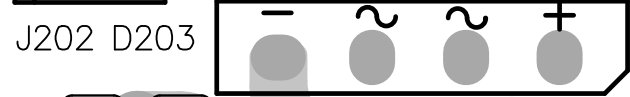
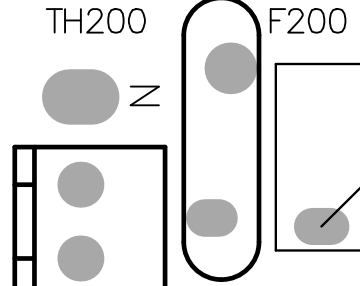
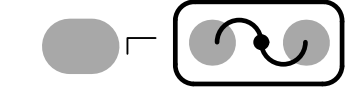

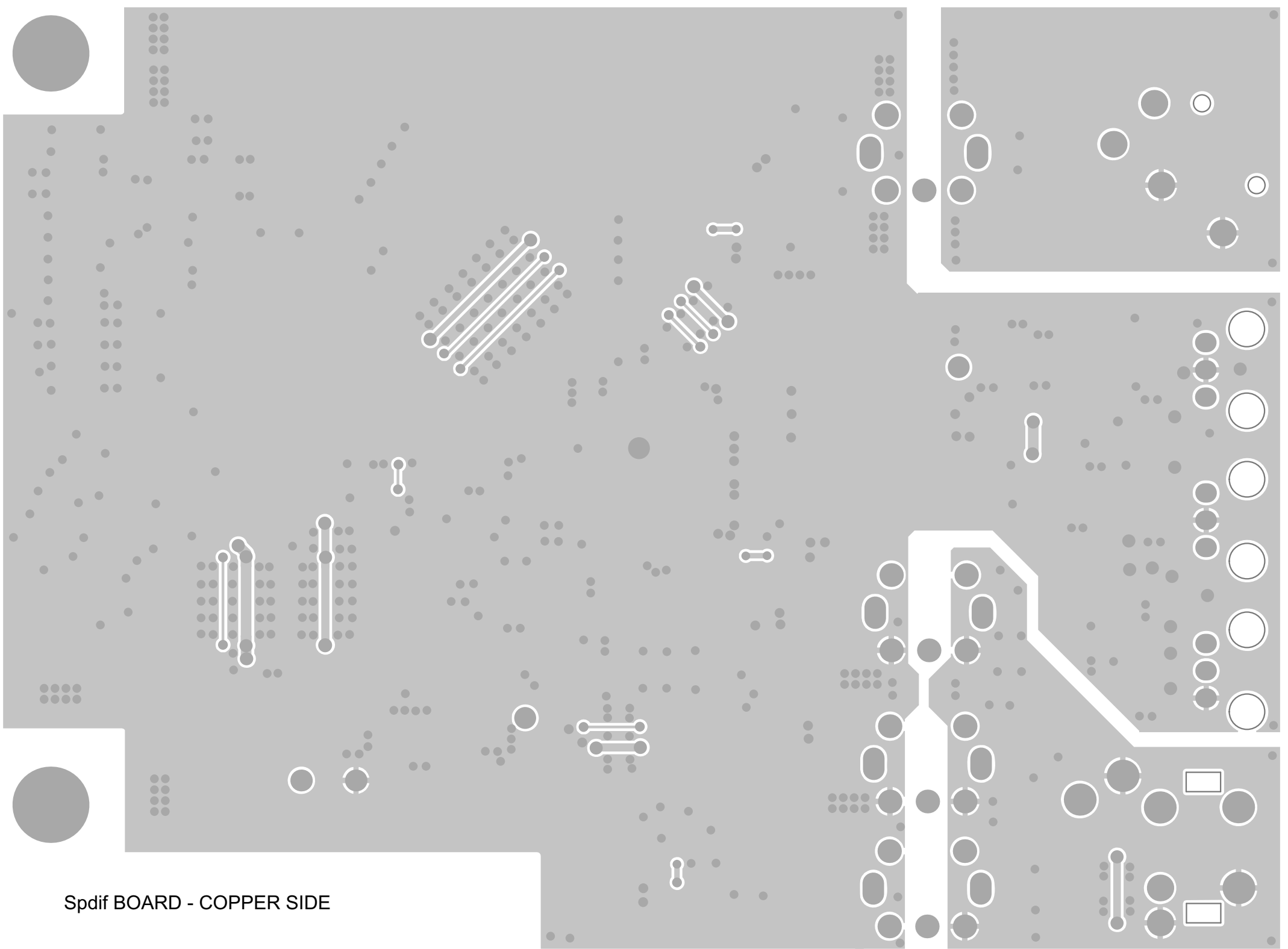

Spdif BOARD - COPPER SIDE

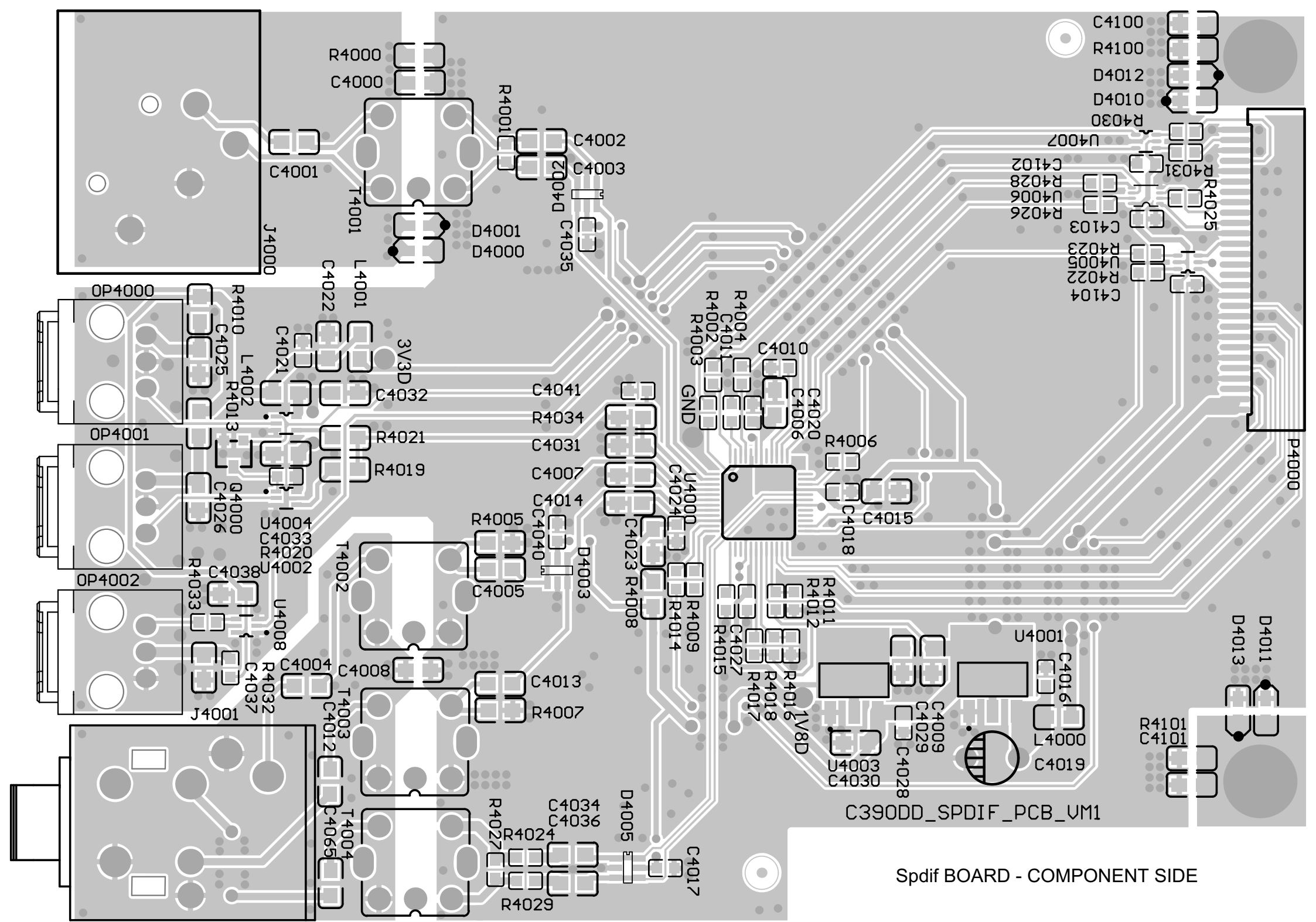

Spdif BOARD - COMPONENT SIDE

C390DD_SPDIF_PCB_VM1

SPK BOARD - COPPER SIDE

C944
C945
C946
C947

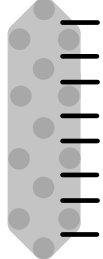

C940
C941
C942
C943

C964
C965
C966
C967

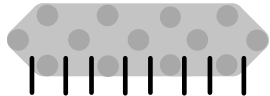

C960
C961
C962
C963

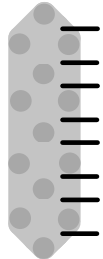

C959
C958
C957
C956

C968
C969
C970
C971



C976
C977
C978
C979

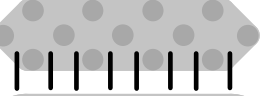

C972
C973
C974
C975

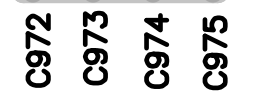

C936
C937
C938
C939

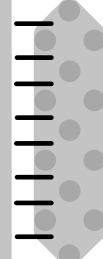

C952
C953
C954
C955

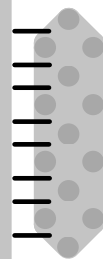

C935
C934
C933
C932

C948
C949
C950
C951

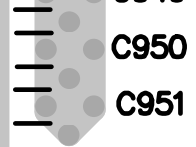

LCH

RCH

L902

L901

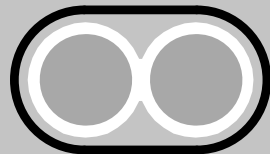
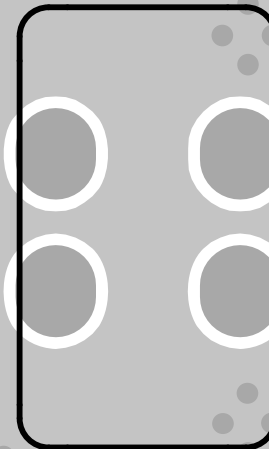
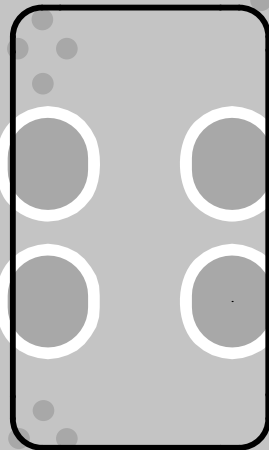

J4

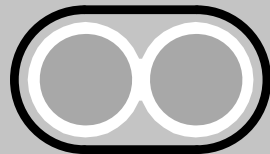

J2

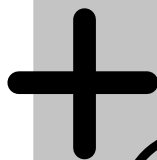

J5

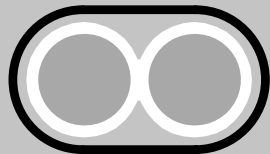
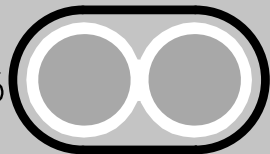

J6



C390DD SPK BOARD V12.0

USB BOARD - COPPER SIDE

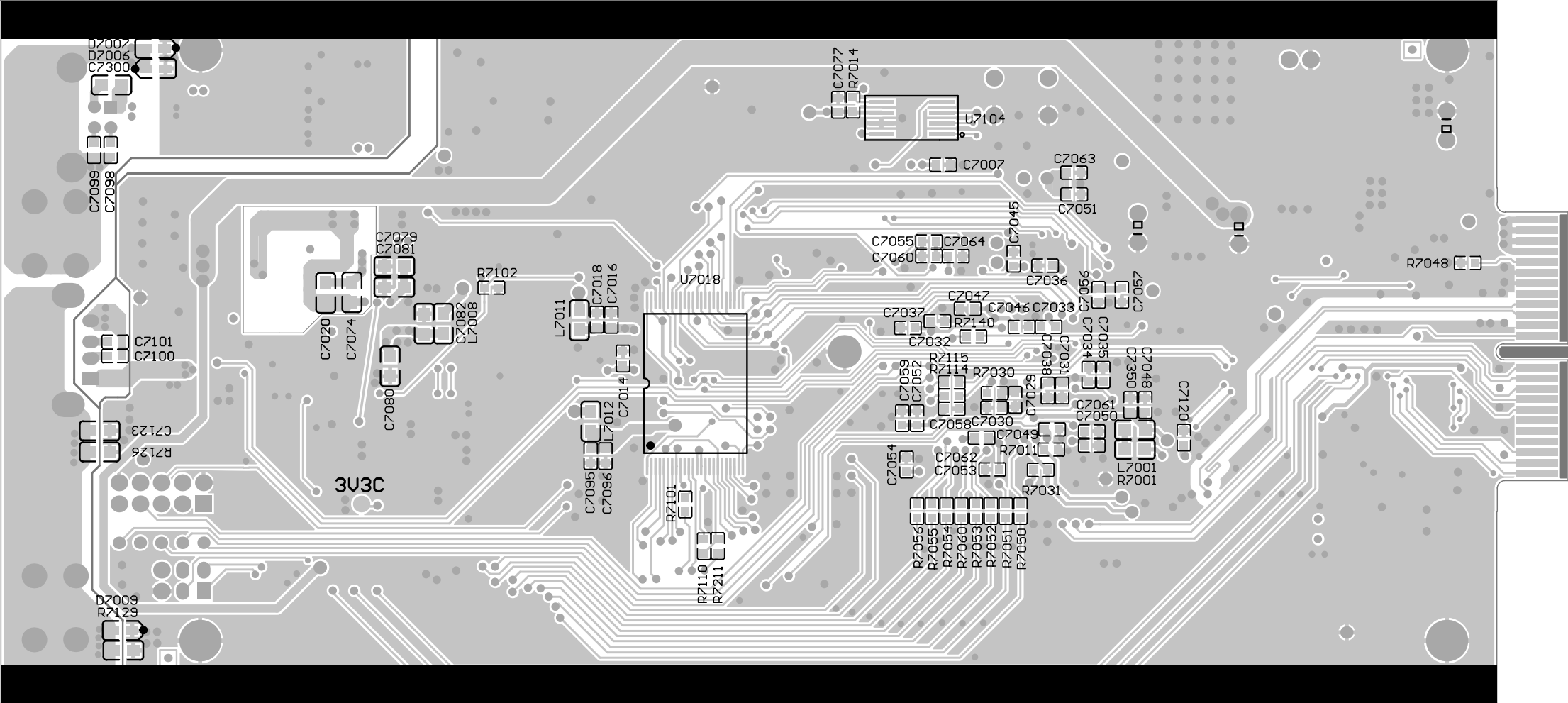

USB BOARD - COMPONENT SIDE

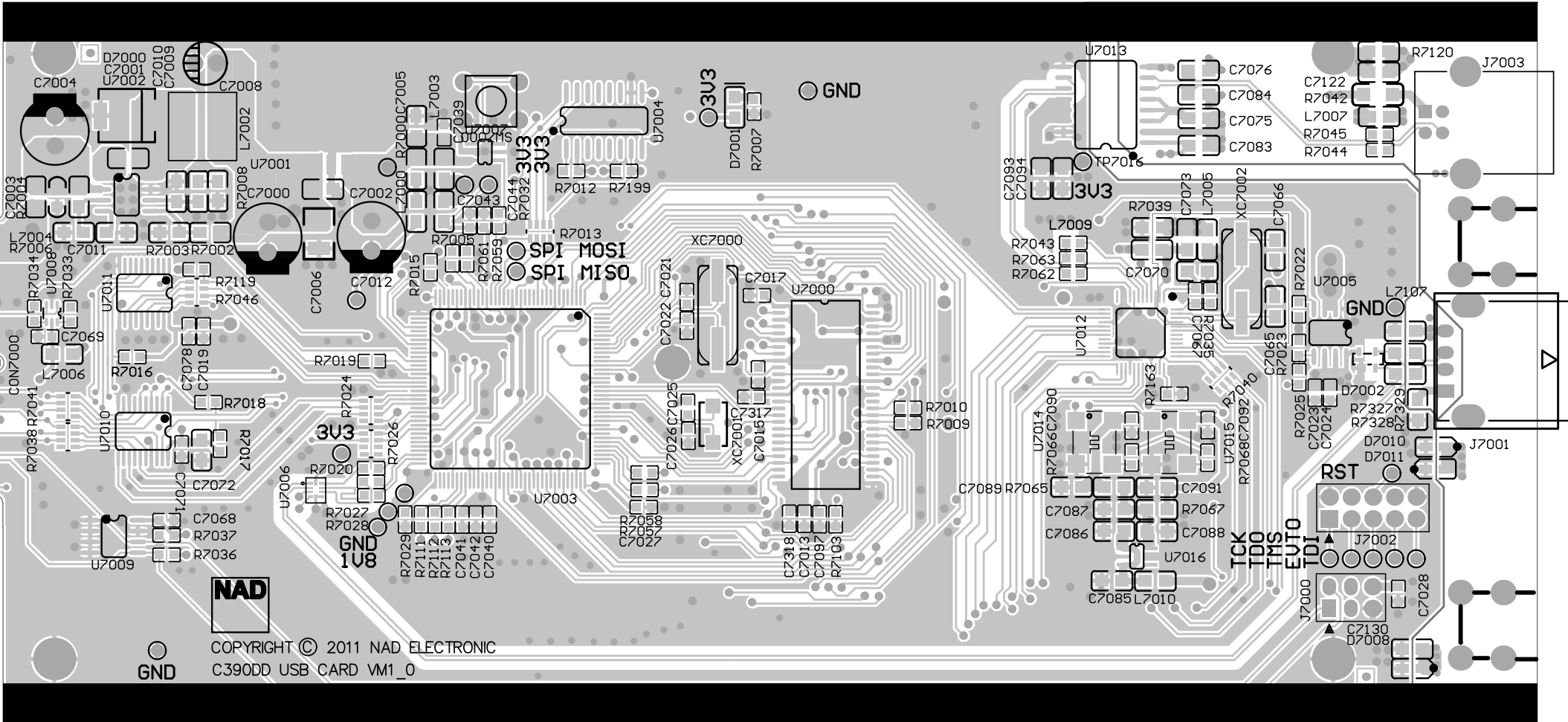

SCHIMATIC DIOGRAM

AMP-1

Feedback processor

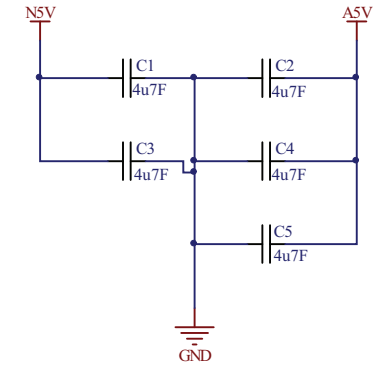
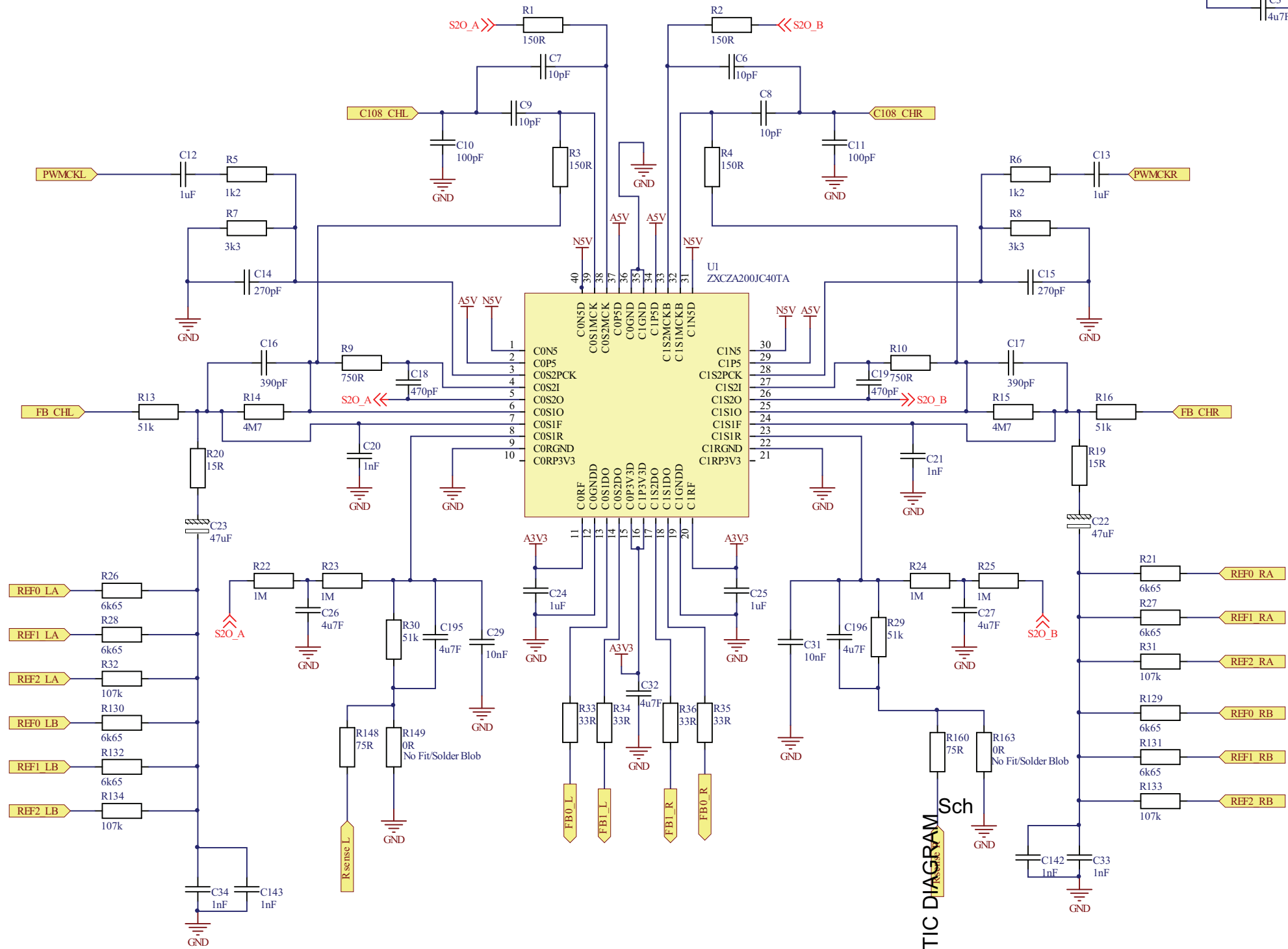

SCHIMATIC DIAGRAM

AMP-2

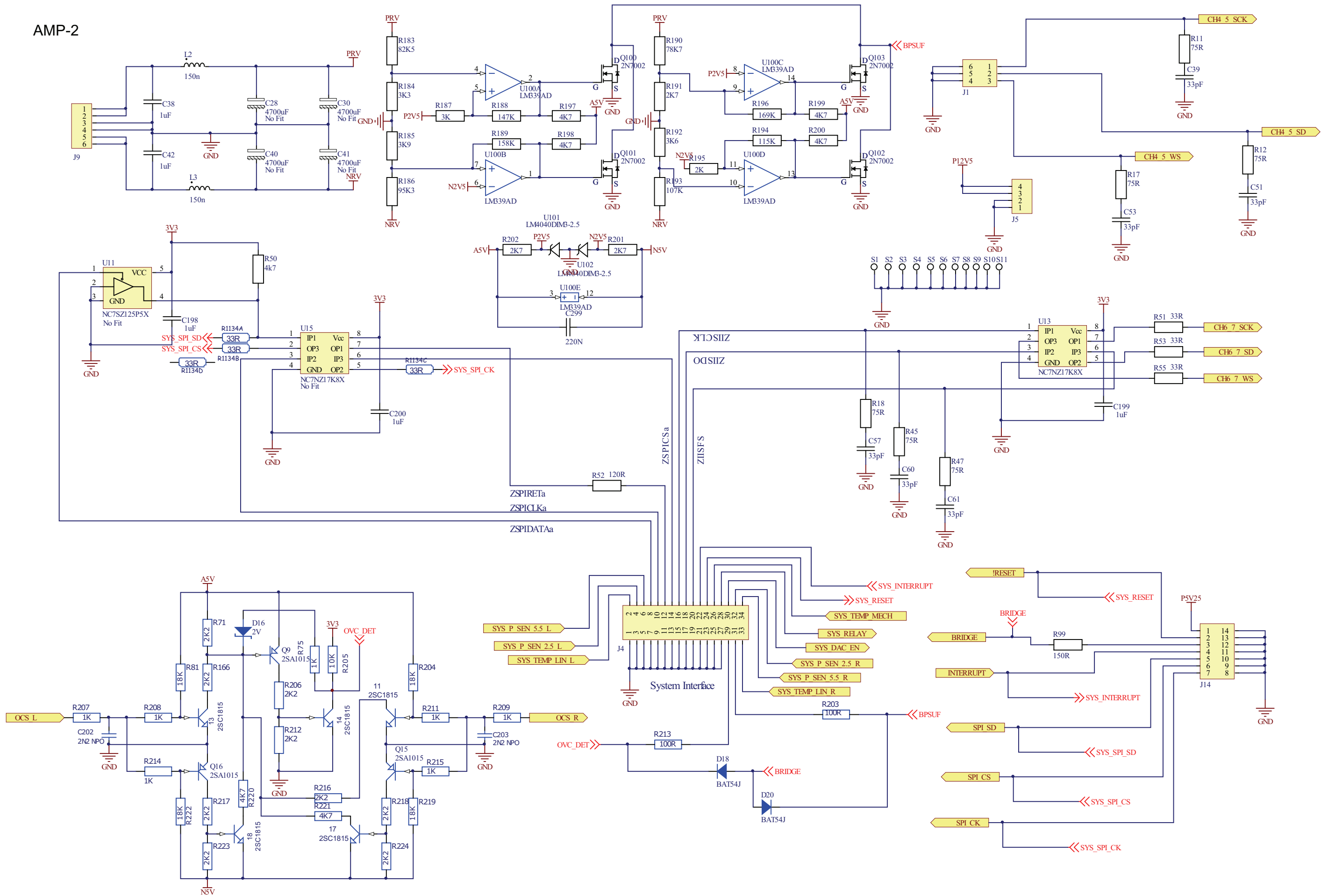

AMP-3

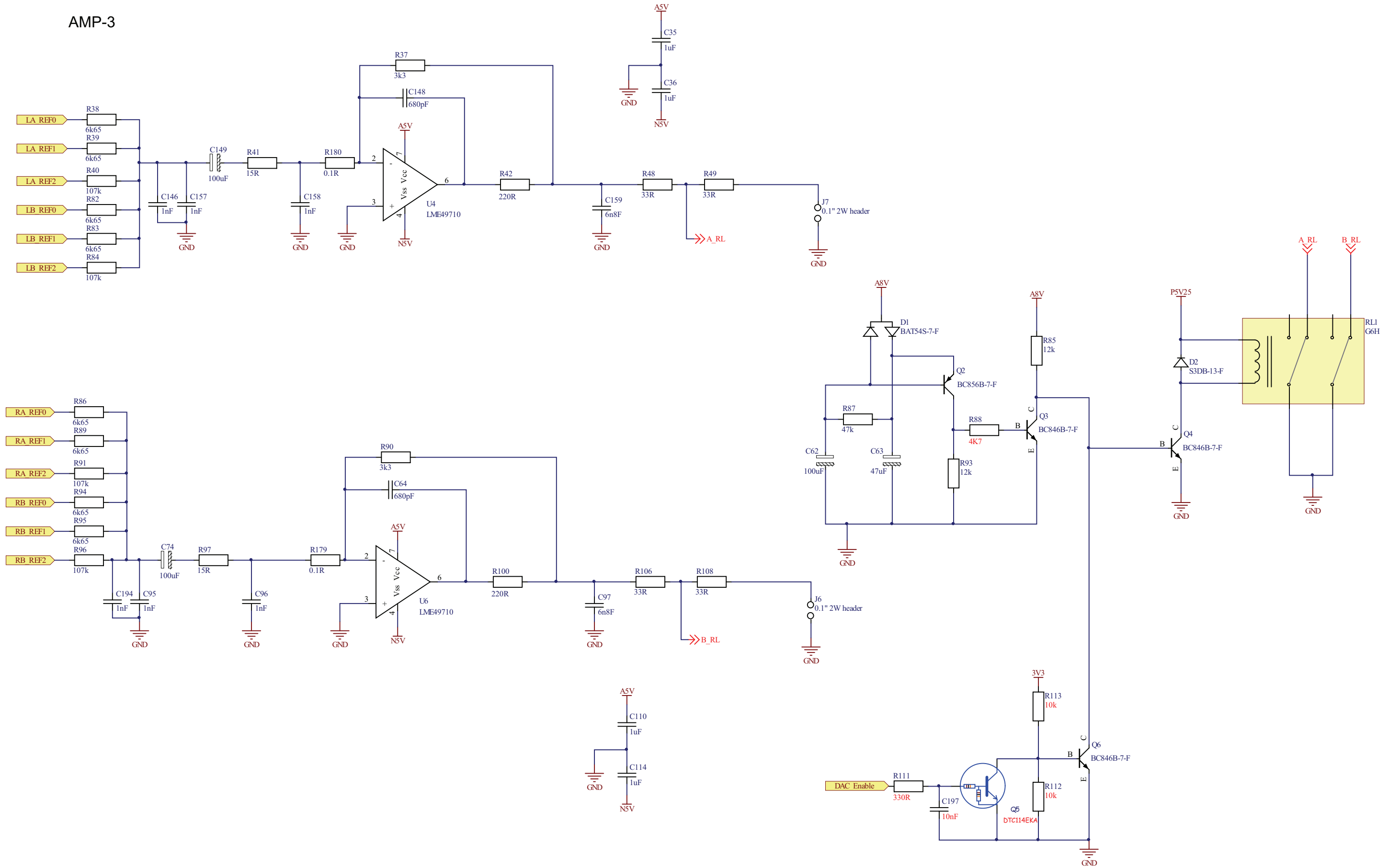

AMP-4

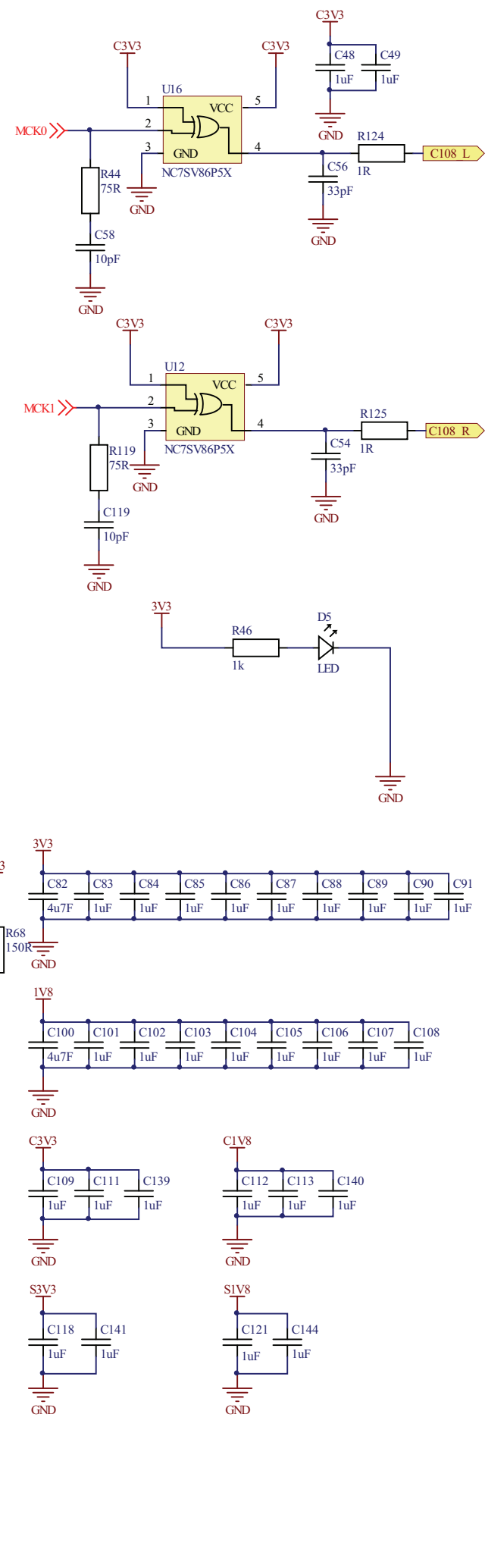
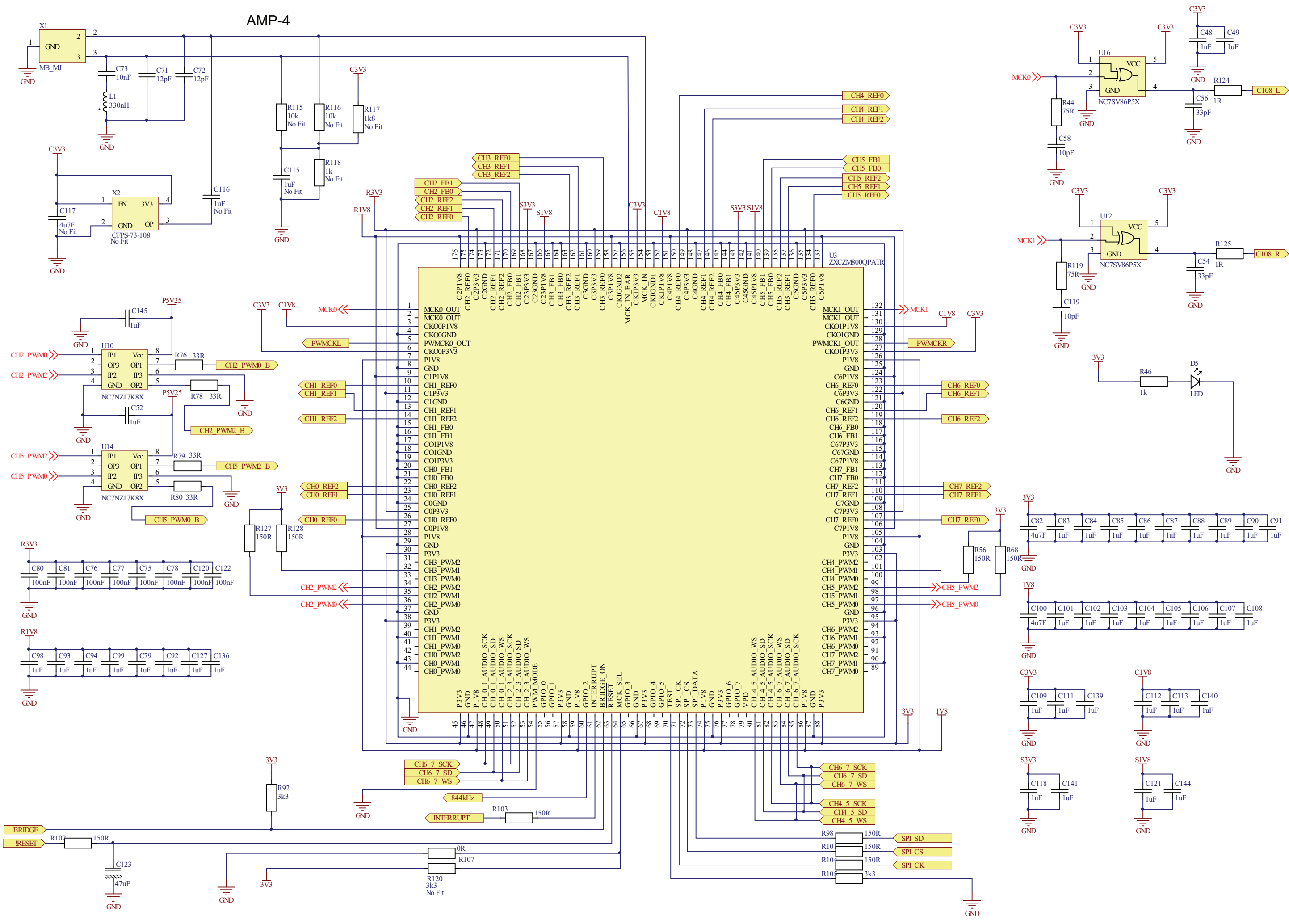

AMP-5 Output Stage

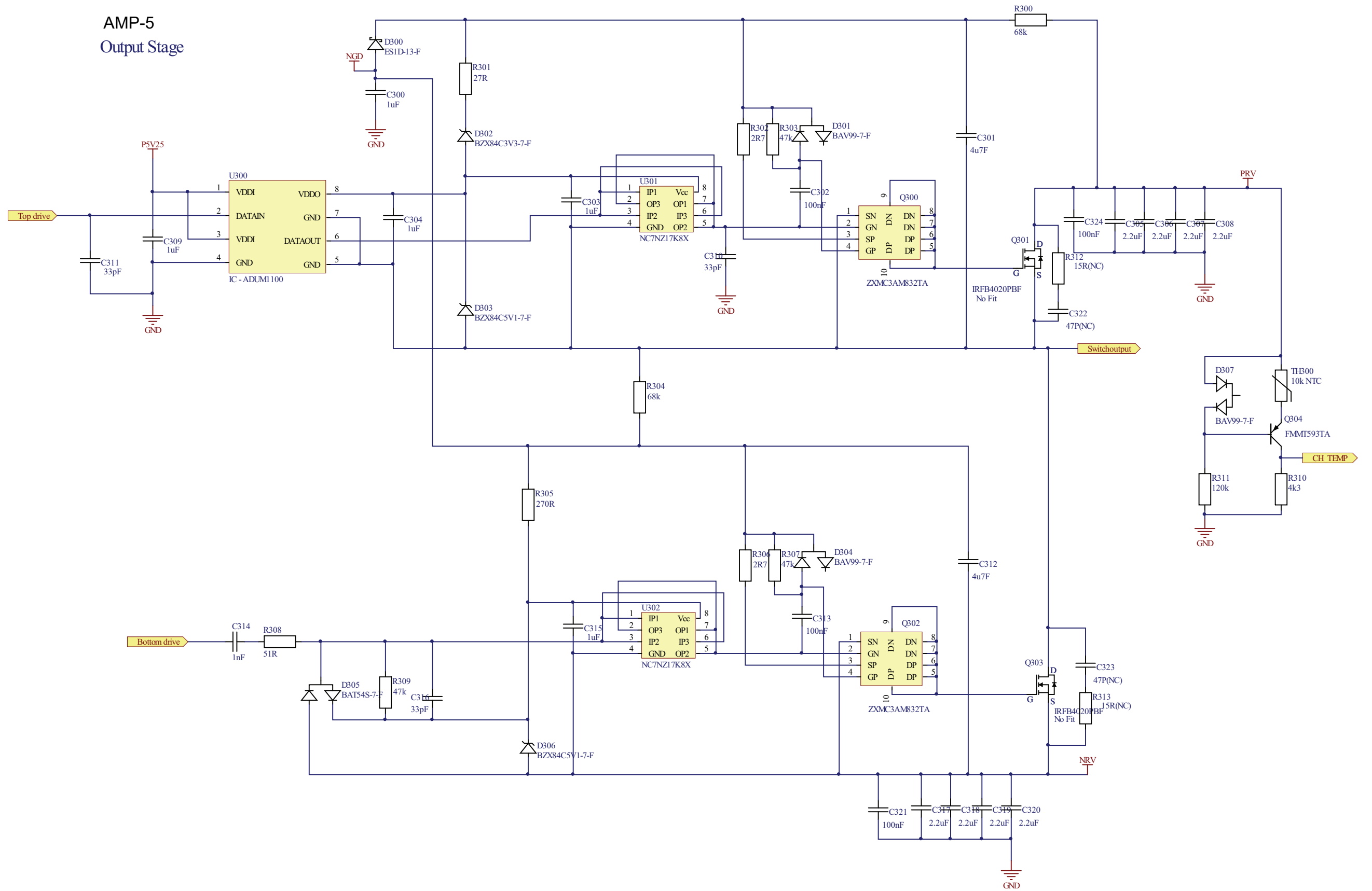

AMP-6
Output Filter

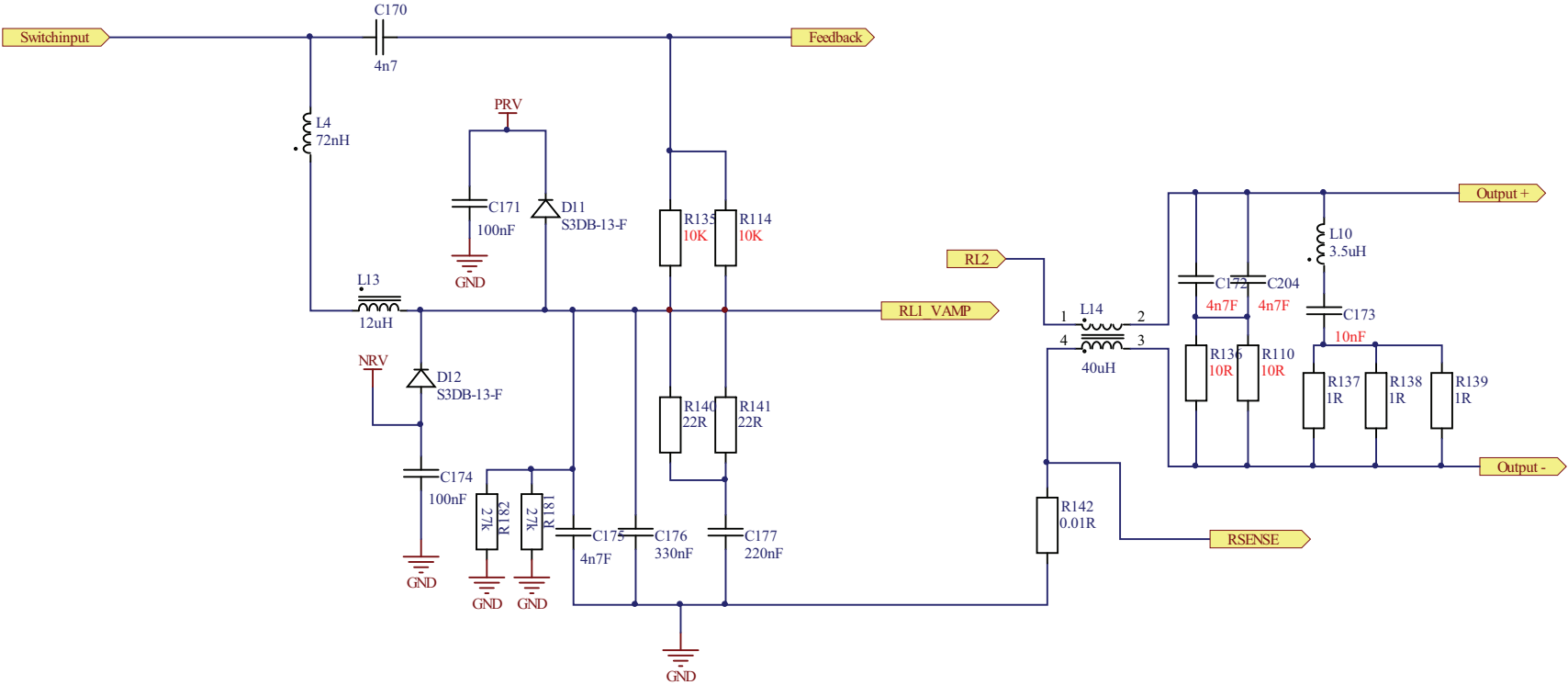

AMP-7 Power Sense

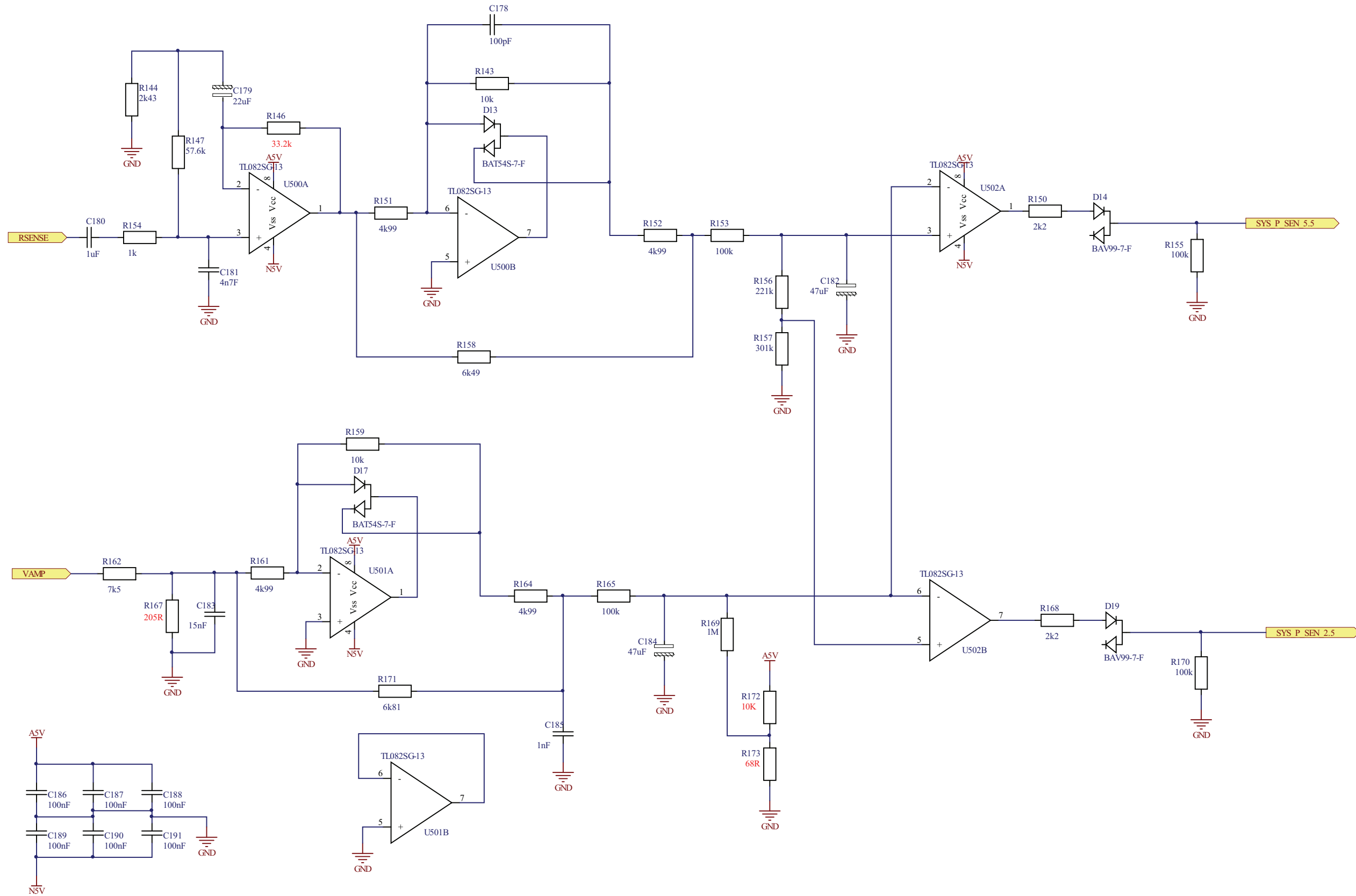

AMP-8

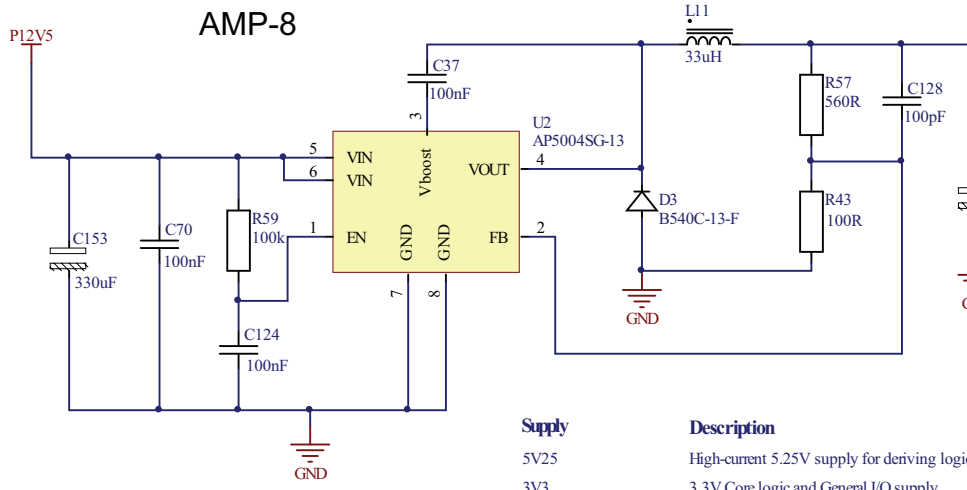

Supply	Description
5V25	High-current 5.25V supply for deriving logic supplies
3V3	3.3V Core logic and General I/O supply
1V8	1.8V Core logic supply
C3V3	3.3V Clock supply
S3V3	Filtered from C3V3 for STAMPS
C1V8	1.8V Clock supply
S1V8	Filtered from C1V8 for STAMPS
R1V8	Filtered from C1V8 for References
A8V	8V supply for deriving analogue supplies
N8V	-8V supply for deriving analogue supplies
A5V	5V Analogue supply
N5V	-5V Analogue supply
R3V3	3.3V low-noise supply for references
A3V3	3.3V Analogue supply for start up
P10V4	10.4V supply for NGD, NRV A8V and N8V
NGD	Bias for gate drive: 10.4V w.r.t. NRV
P12V5	12.5V input voltage

Power Supplies

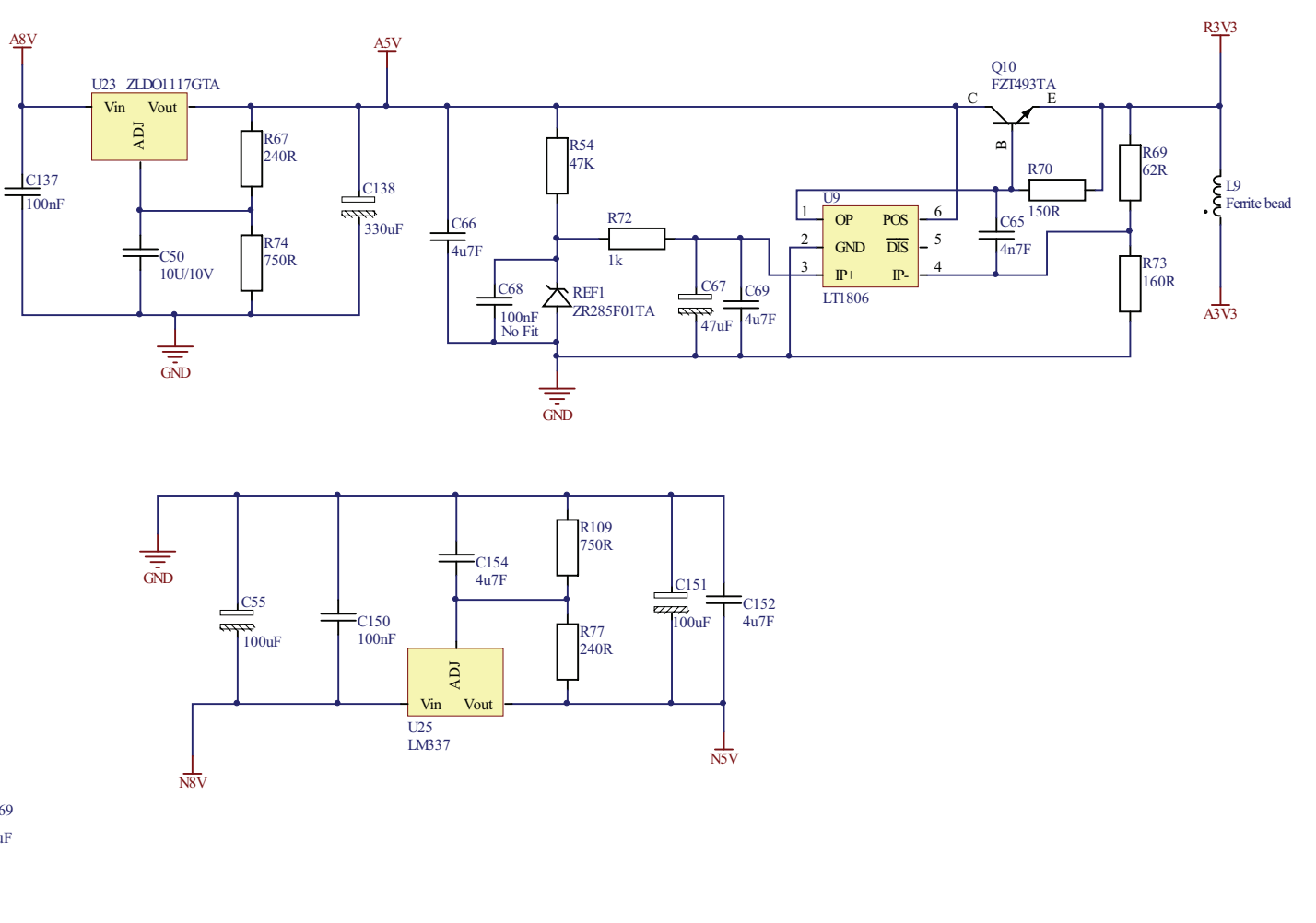
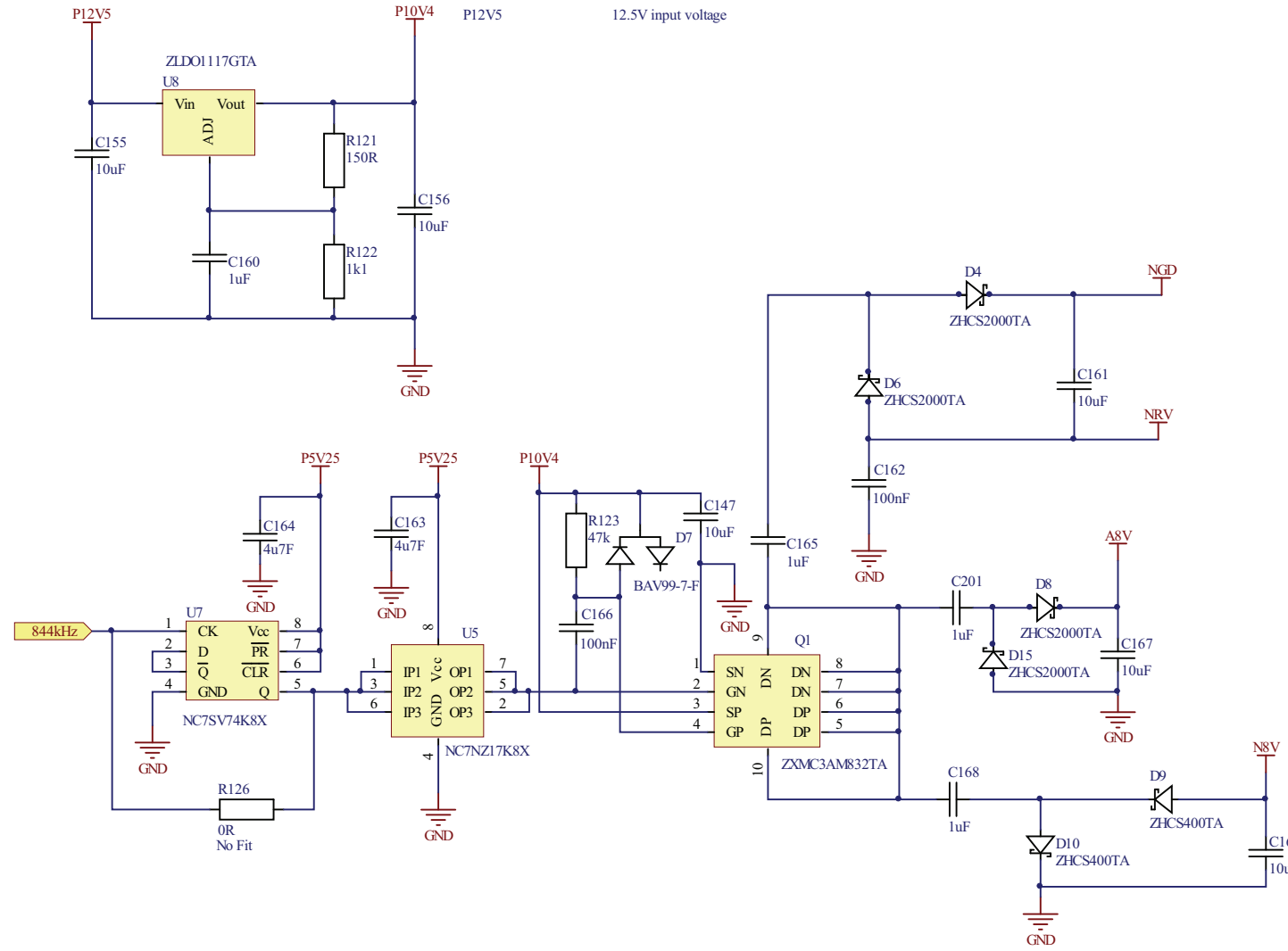
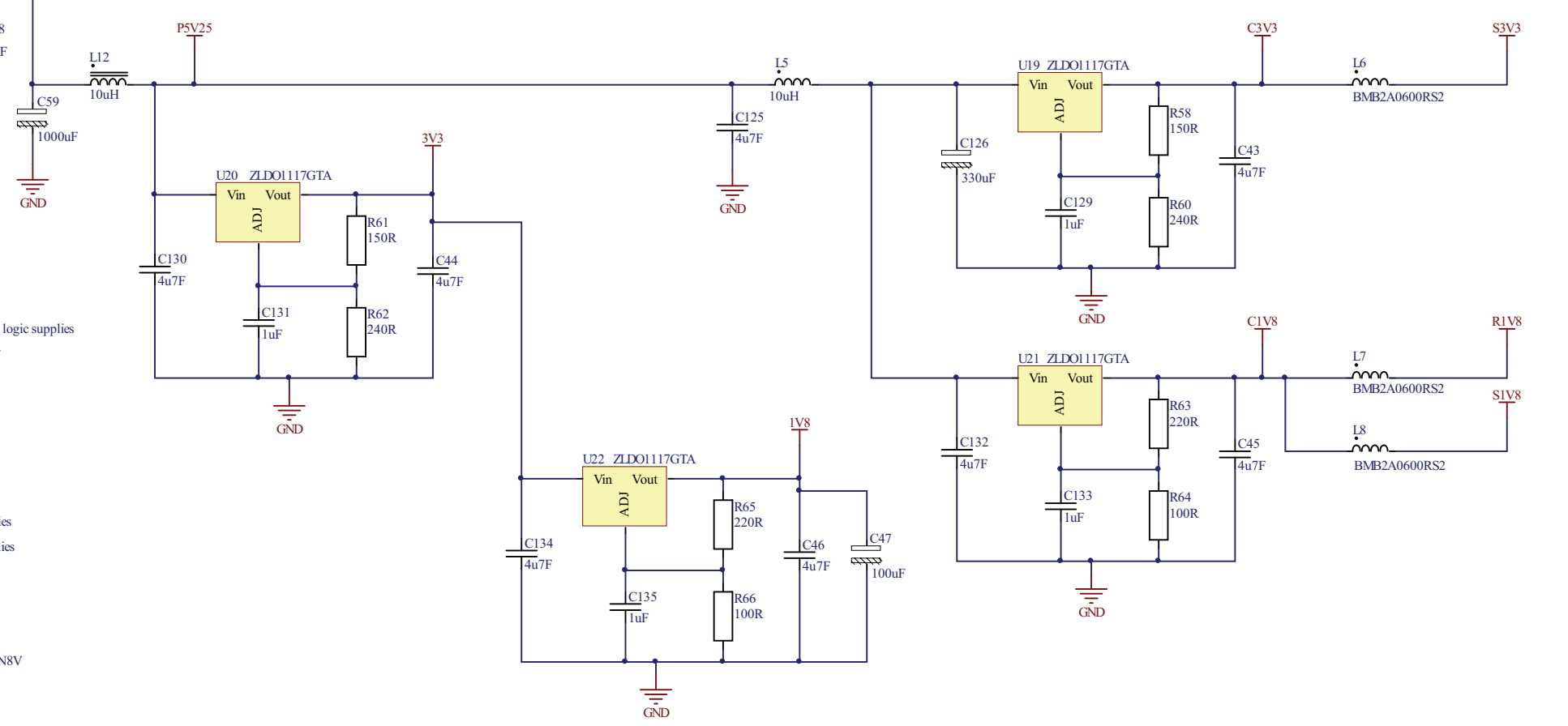

AMP-9
Output Relay

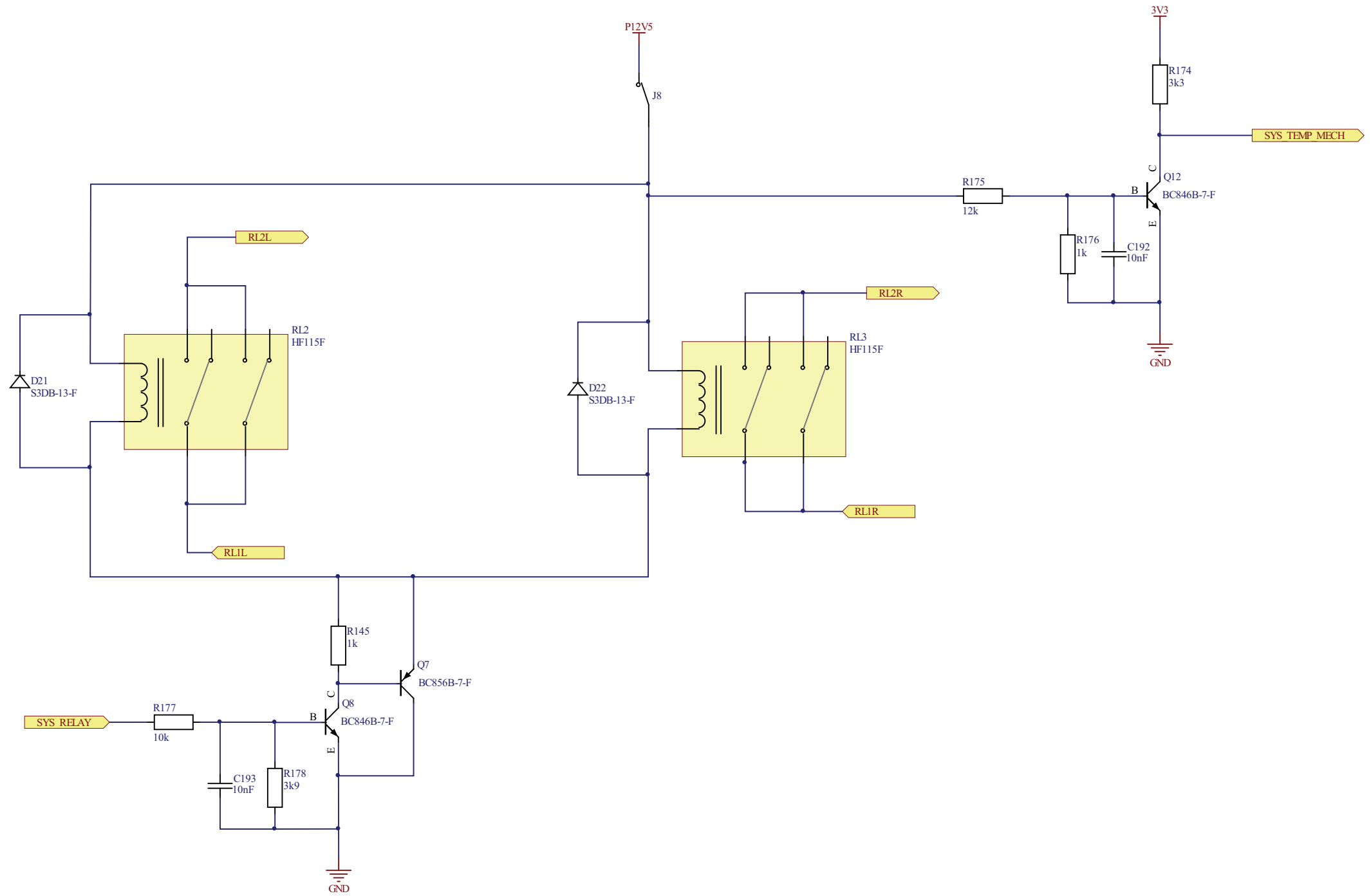

AMP Board

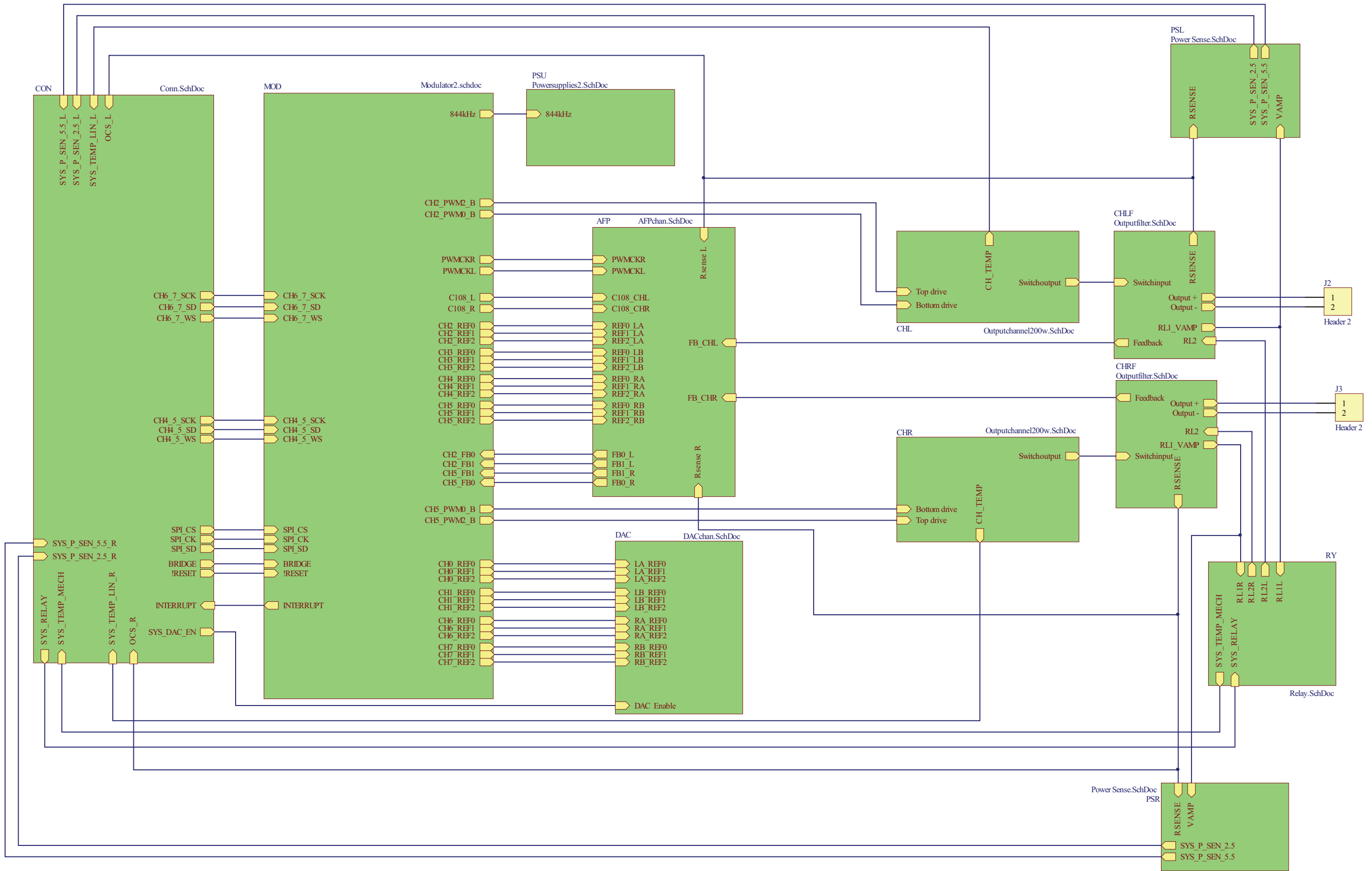

FPP Board

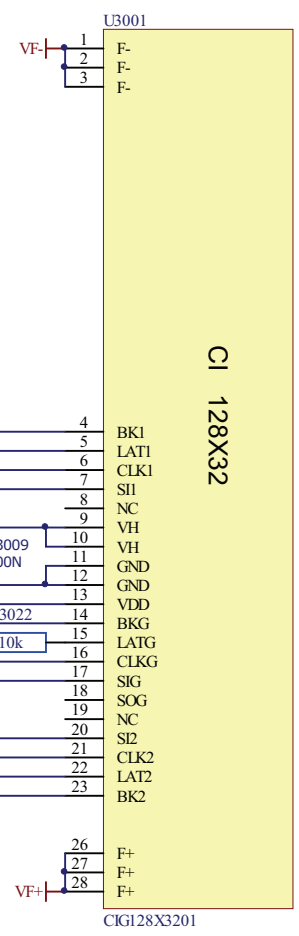
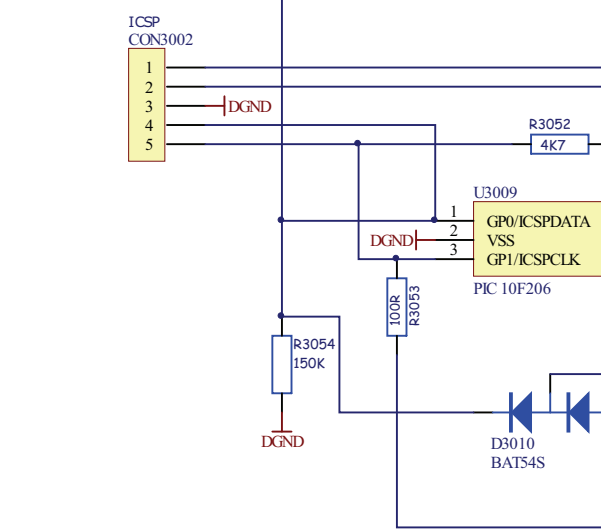
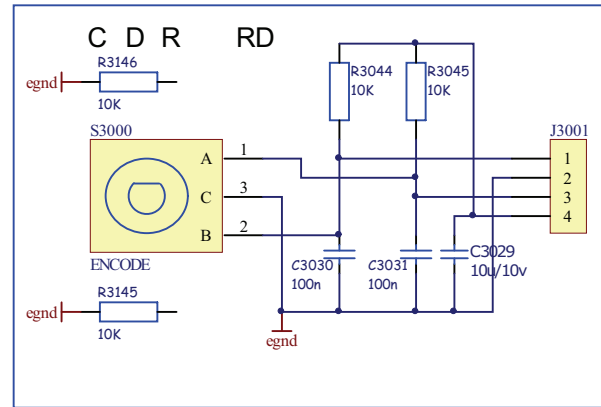
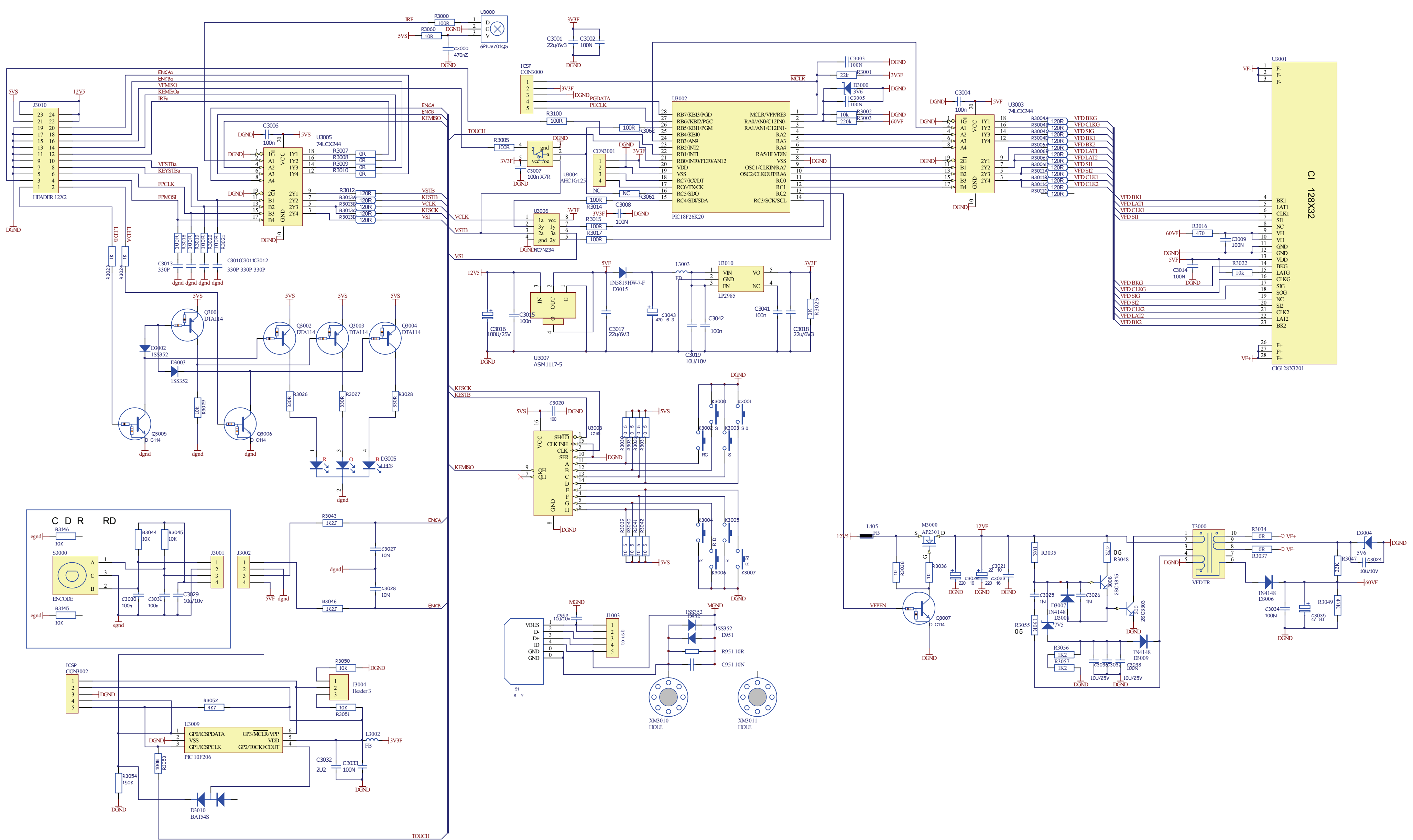
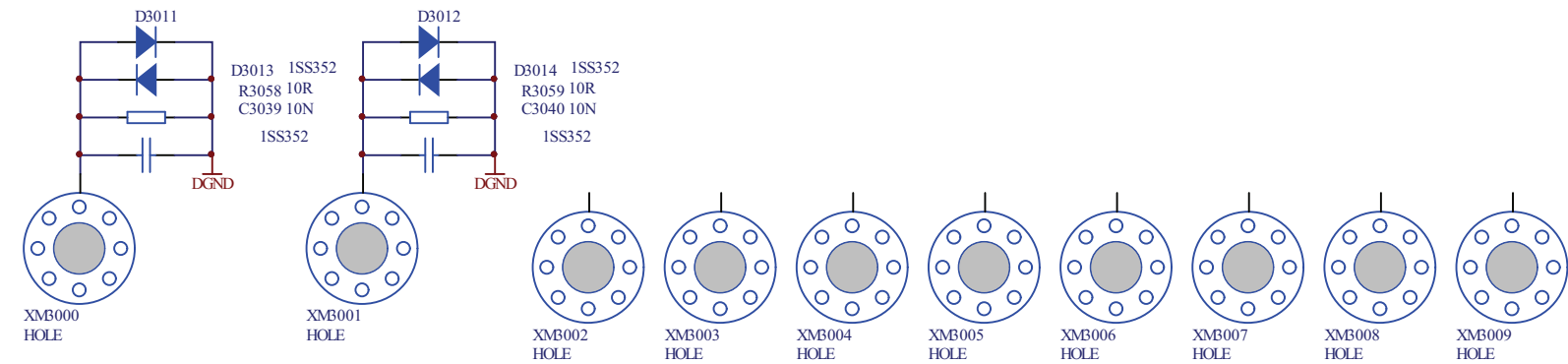

HDMI Board

HDMI 3 input
HDMI 3 input

<input type="checkbox"/>	CEC
<input type="checkbox"/>	CEC-DI
<input type="checkbox"/>	HP_TX
<input type="checkbox"/>	HDMI_TX_RESERVED
<input type="checkbox"/>	DDCTX_SDA
<input type="checkbox"/>	DDCTX_SCL
<input type="checkbox"/>	TX_CN
<input type="checkbox"/>	TX_CP
<input type="checkbox"/>	TX_0N
<input type="checkbox"/>	TX_0P
<input type="checkbox"/>	TX_1N
<input type="checkbox"/>	TX_1P
<input type="checkbox"/>	TX_2N
<input type="checkbox"/>	TX_2P
<input type="checkbox"/>	PWRDNB
<input type="checkbox"/>	DUT_RESET
<input type="checkbox"/>	SPI_SCK
<input type="checkbox"/>	SPI_CS
<input type="checkbox"/>	SPI_MOSI
<input type="checkbox"/>	SPI_MISO
<input type="checkbox"/>	INT2_RX
<input type="checkbox"/>	INT_RX
<input type="checkbox"/>	INT_TX
<input type="checkbox"/>	CEC
<input checked="" type="checkbox"/>	UC_SCL
<input checked="" type="checkbox"/>	RST_N
<input checked="" type="checkbox"/>	CEC-DI
<input checked="" type="checkbox"/>	UC_SDA
<input checked="" type="checkbox"/>	SCL
<input checked="" type="checkbox"/>	SDA

POWER TX
POWER TX

<input type="checkbox"/>	HP_TX
<input type="checkbox"/>	HDMI_TX_RESERVED
<input type="checkbox"/>	DDCTX_SDA
<input type="checkbox"/>	DDCTX_SCL
<input type="checkbox"/>	TX_CN
<input type="checkbox"/>	TX_CP
<input type="checkbox"/>	TX_0N
<input type="checkbox"/>	TX_0P
<input type="checkbox"/>	TX_1N
<input type="checkbox"/>	TX_1P
<input type="checkbox"/>	TX_2N
<input type="checkbox"/>	TX_2P
<input type="checkbox"/>	SPI_CS
<input type="checkbox"/>	SPI_MOSI
<input type="checkbox"/>	SPI_SCK
<input type="checkbox"/>	SPI_MISO
<input type="checkbox"/>	SPISS
<input type="checkbox"/>	MCU_1V8_EN
<input type="checkbox"/>	MCU_3V3_EN
<input type="checkbox"/>	PWRDNB

MCU
MCU

<input type="checkbox"/>	SCL
<input type="checkbox"/>	SDA
<input checked="" type="checkbox"/>	UC_SCL
<input checked="" type="checkbox"/>	UC_SDA
<input type="checkbox"/>	DUT_RESET
<input type="checkbox"/>	INT2_RX
<input type="checkbox"/>	INT_RX
<input type="checkbox"/>	INT_TX
<input type="checkbox"/>	MCU_1V8_EN
<input type="checkbox"/>	MCU_3V3_EN
<input type="checkbox"/>	SPISS

HDMI Board-1

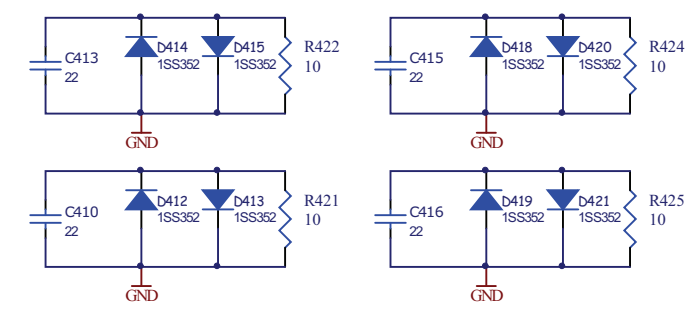
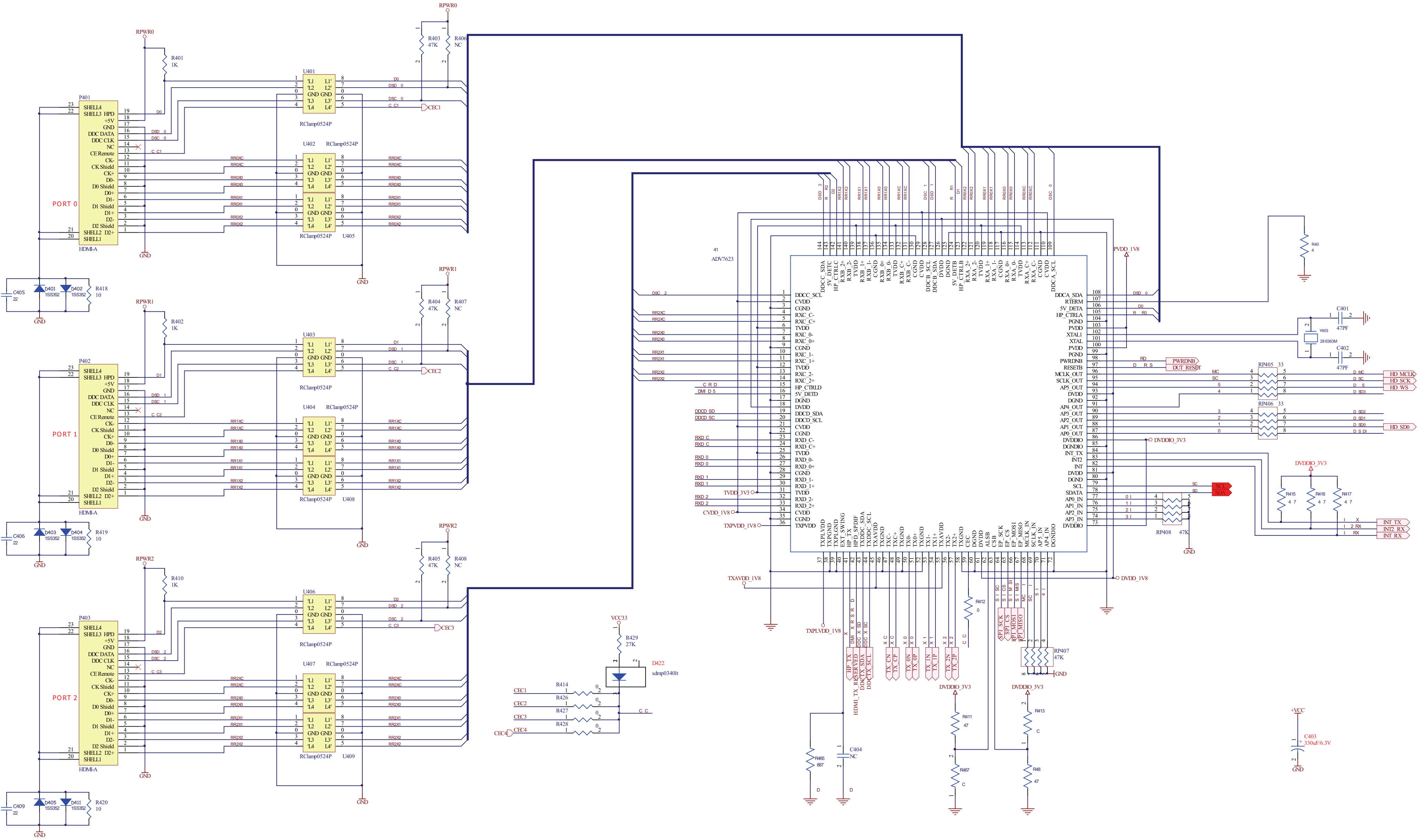

HDMI Board-2

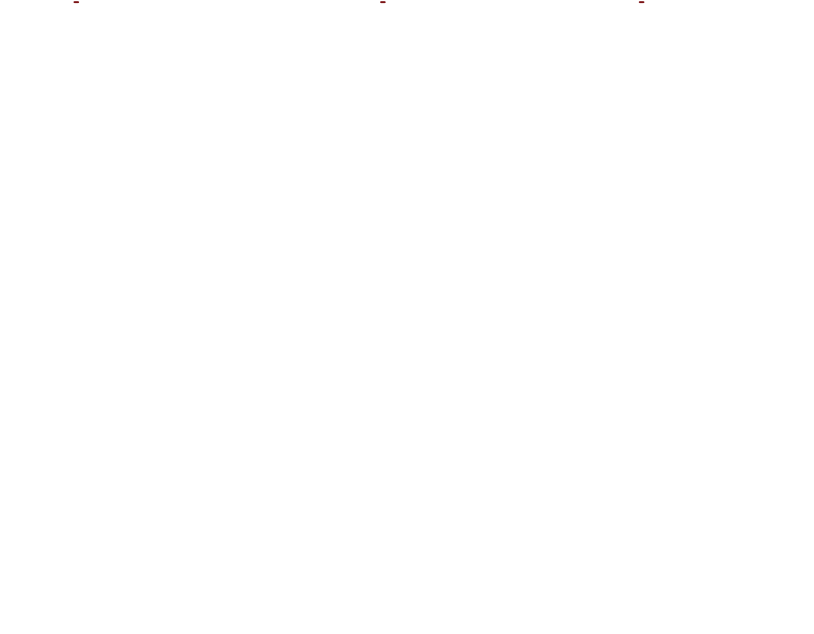
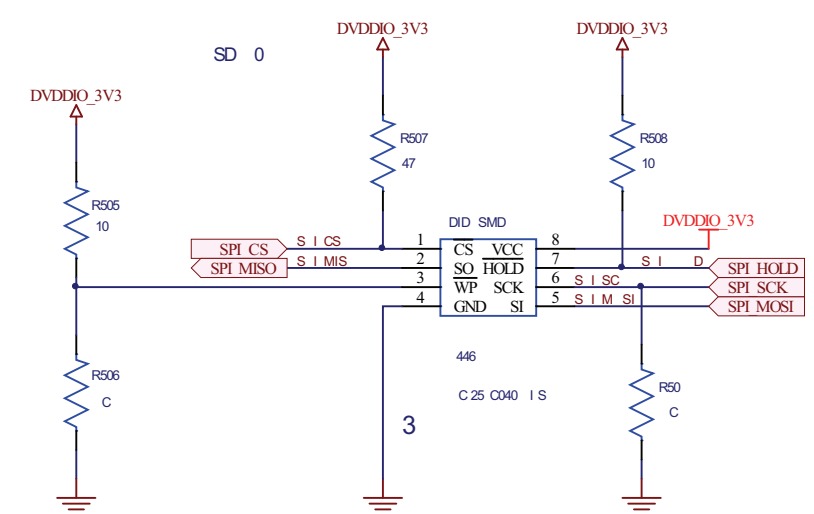
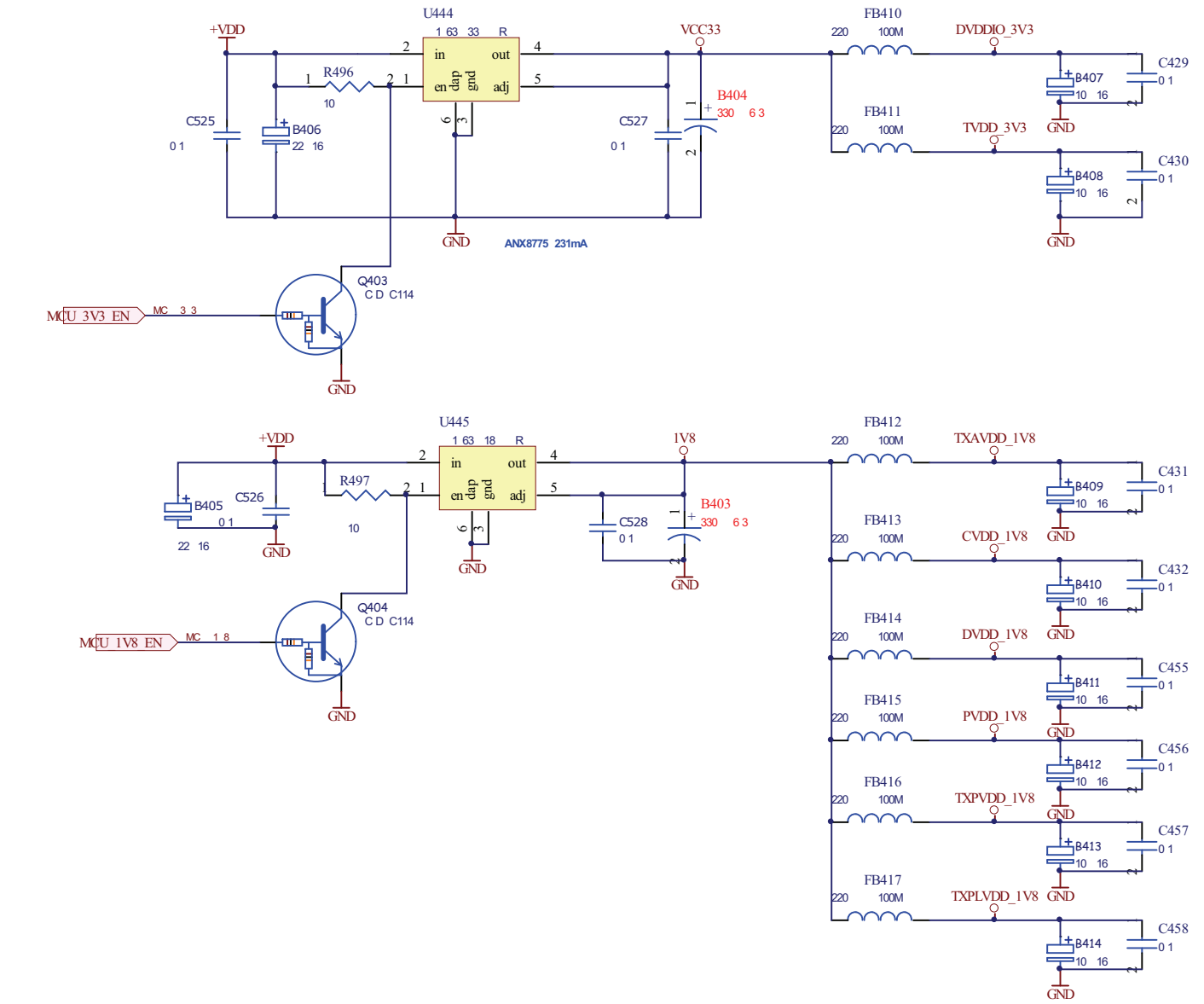
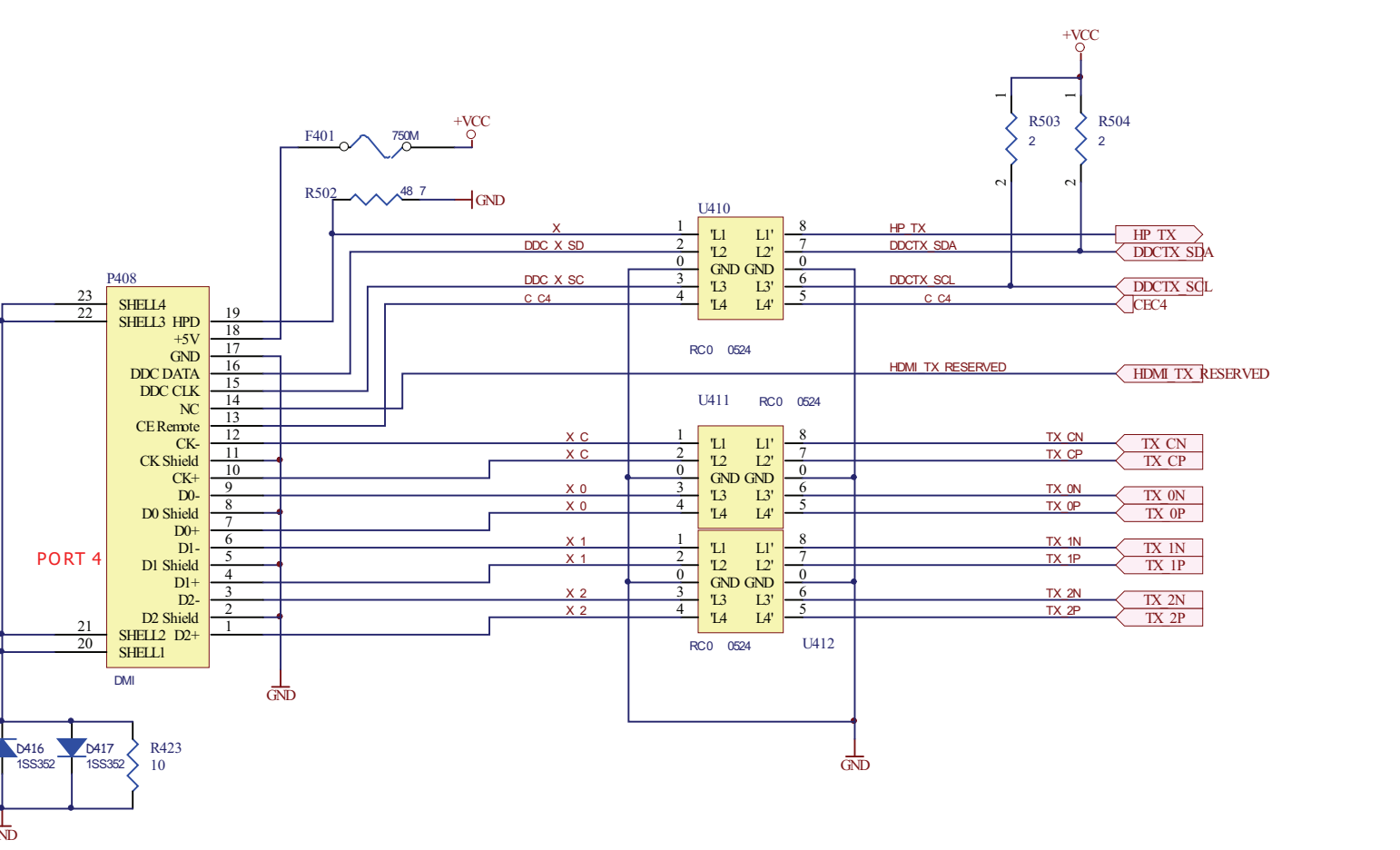
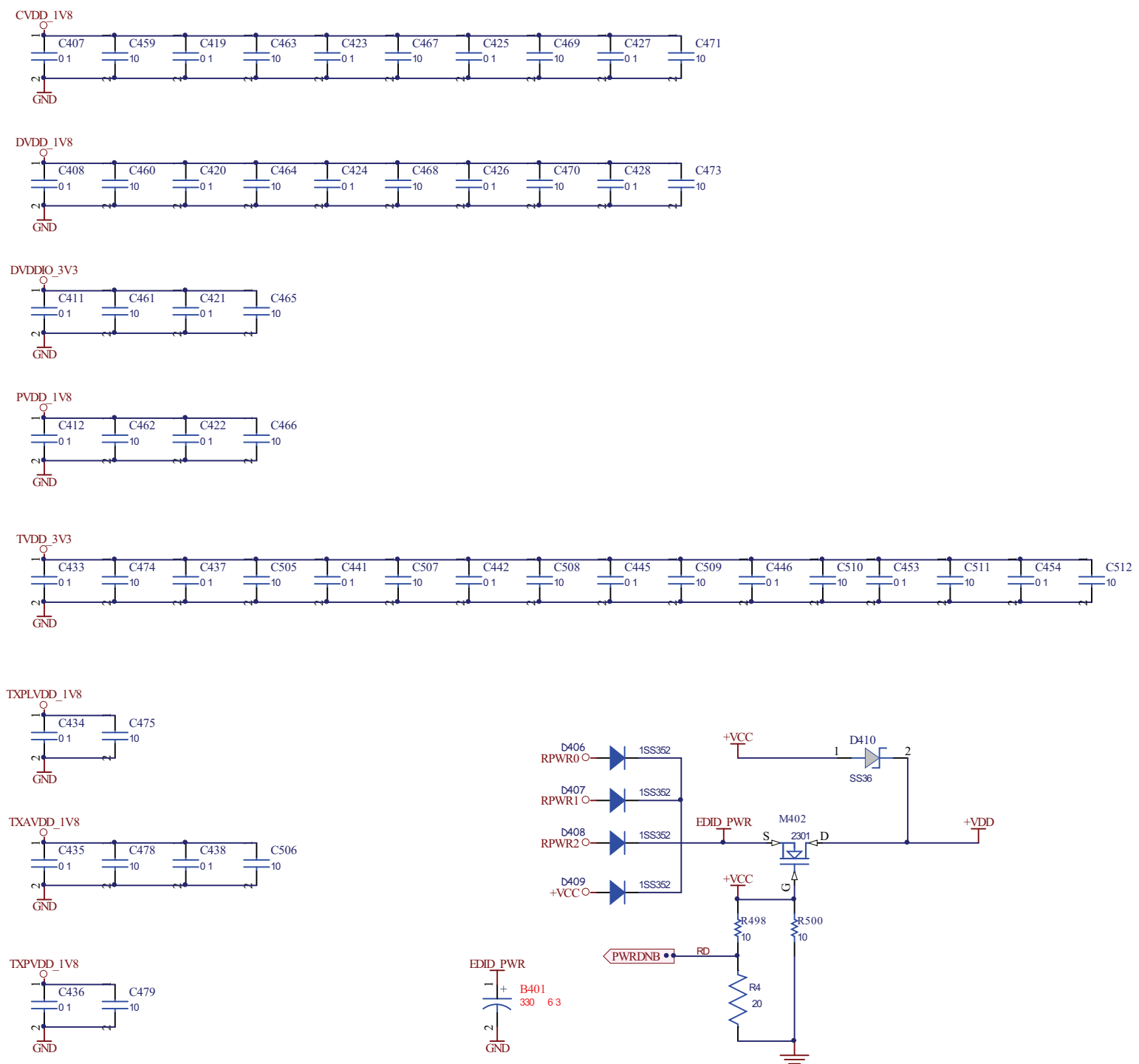

HDMI Board-3

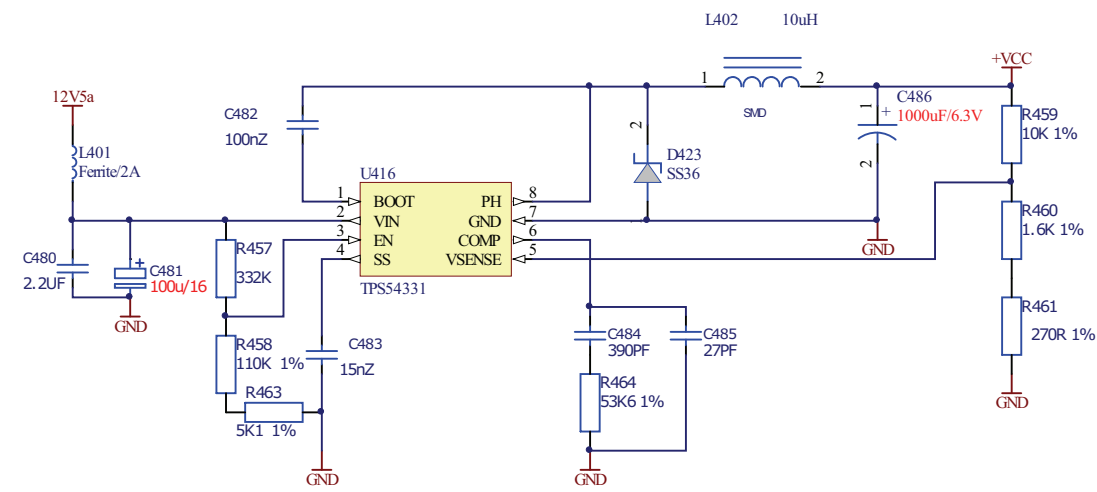
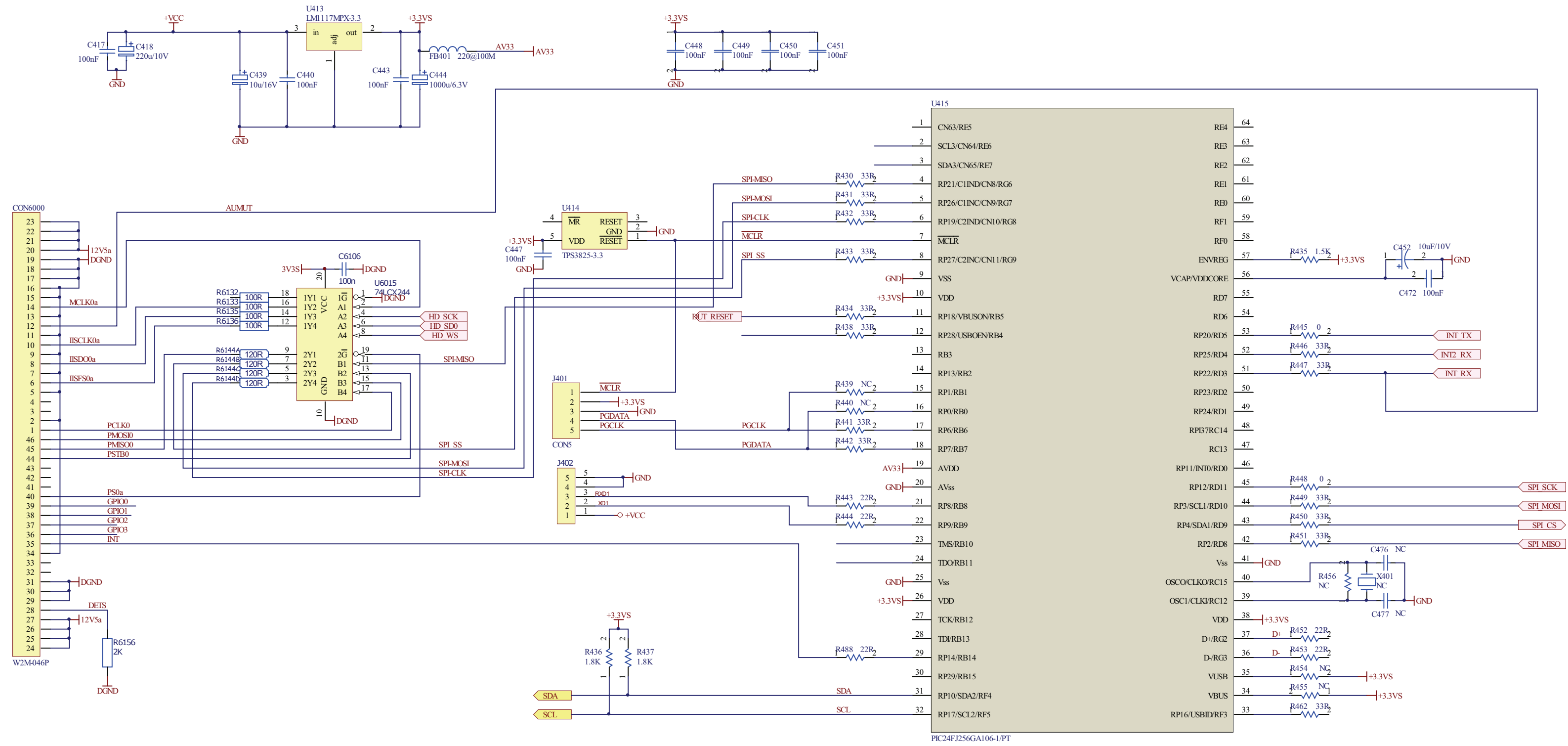

INT Board

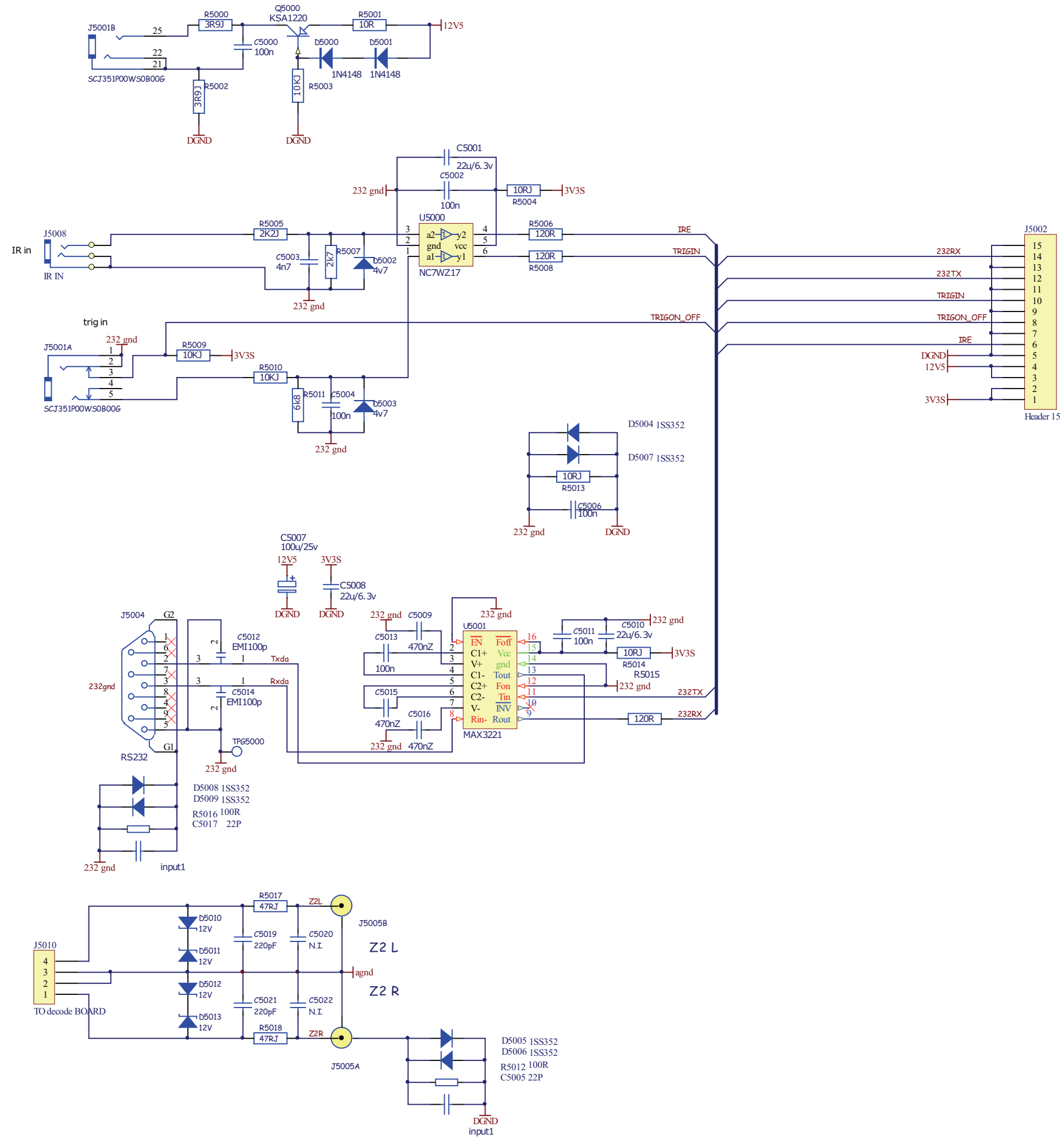

Analog Board

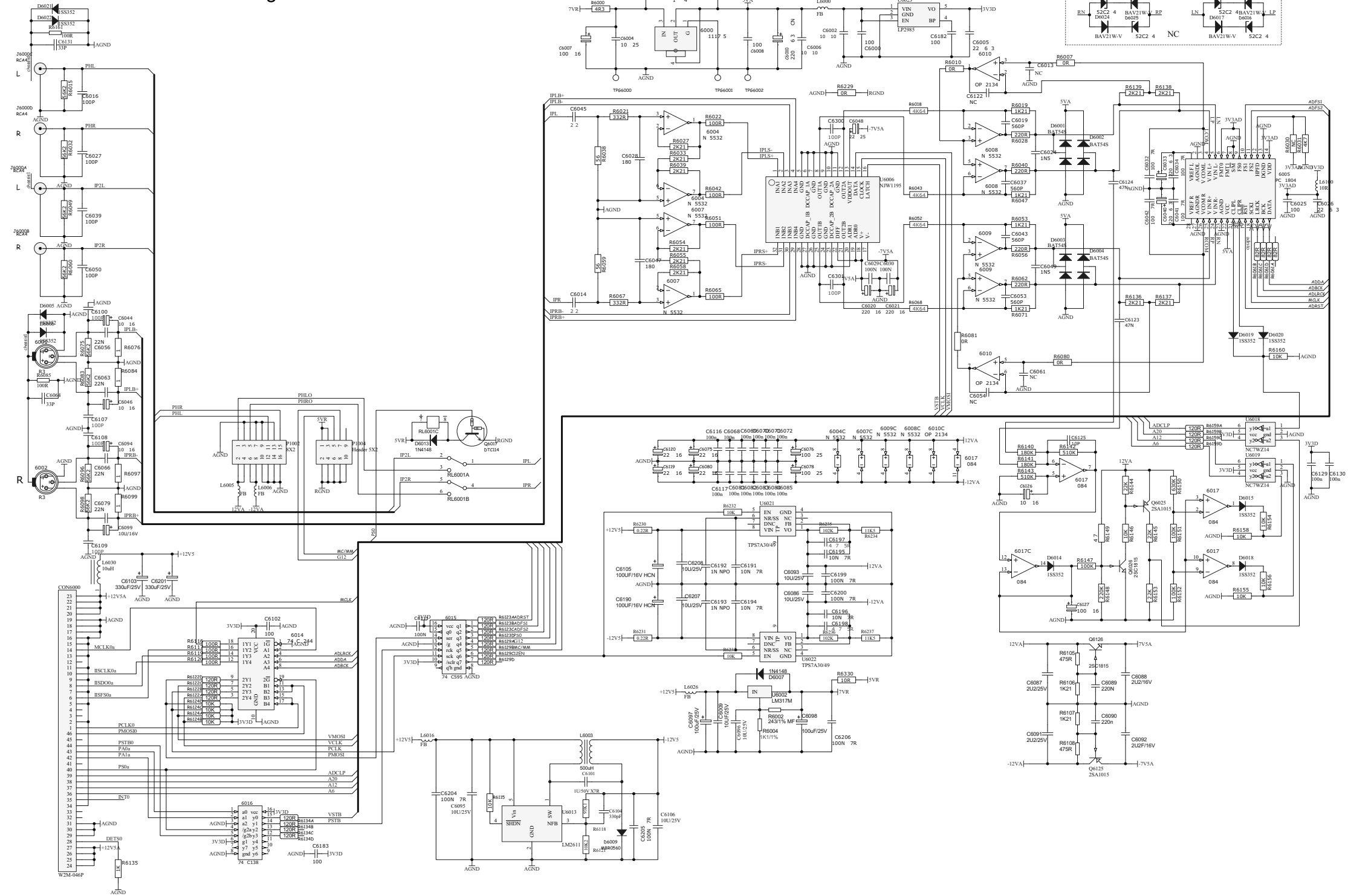

Main Board

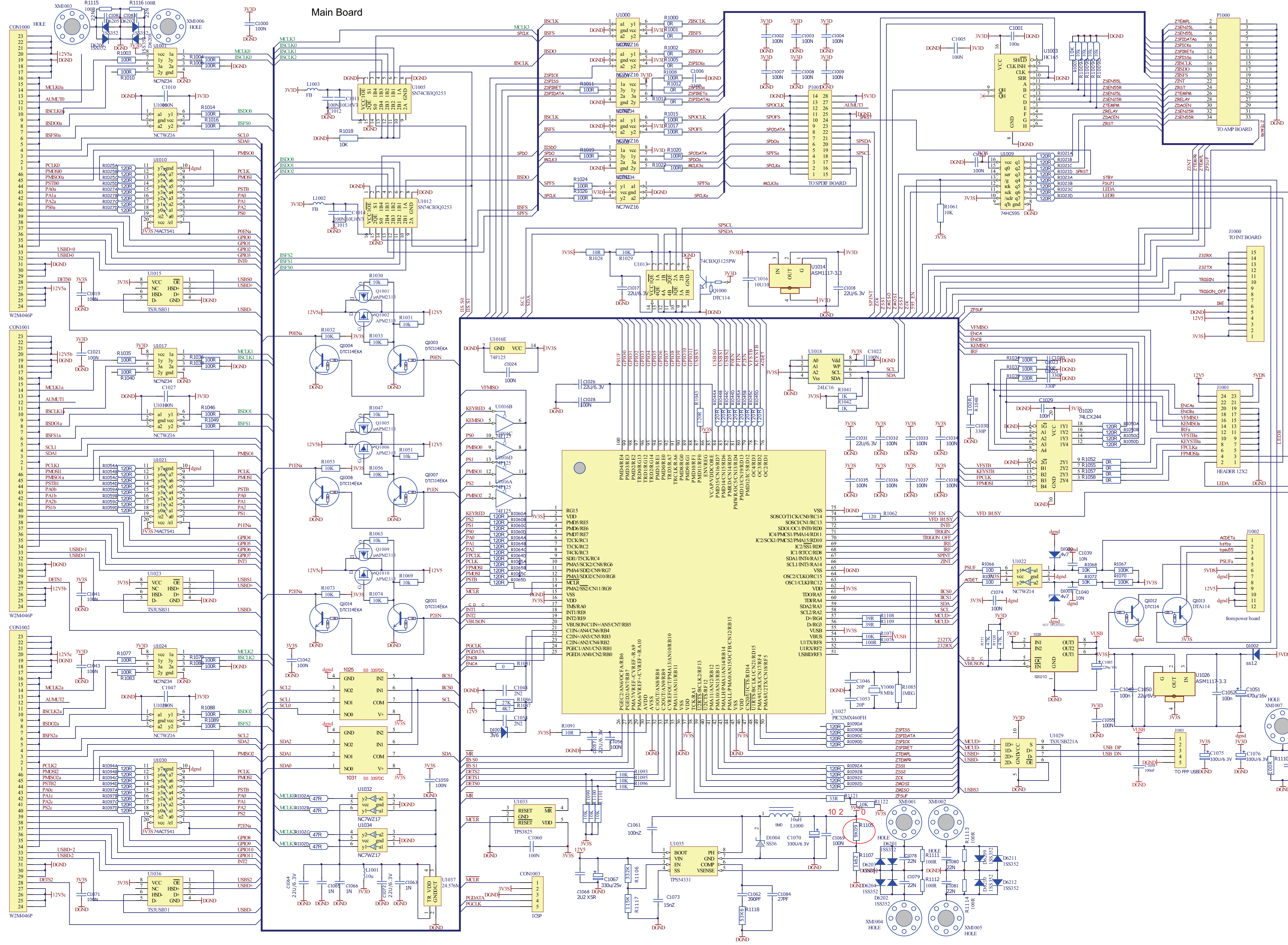

Spdif Board

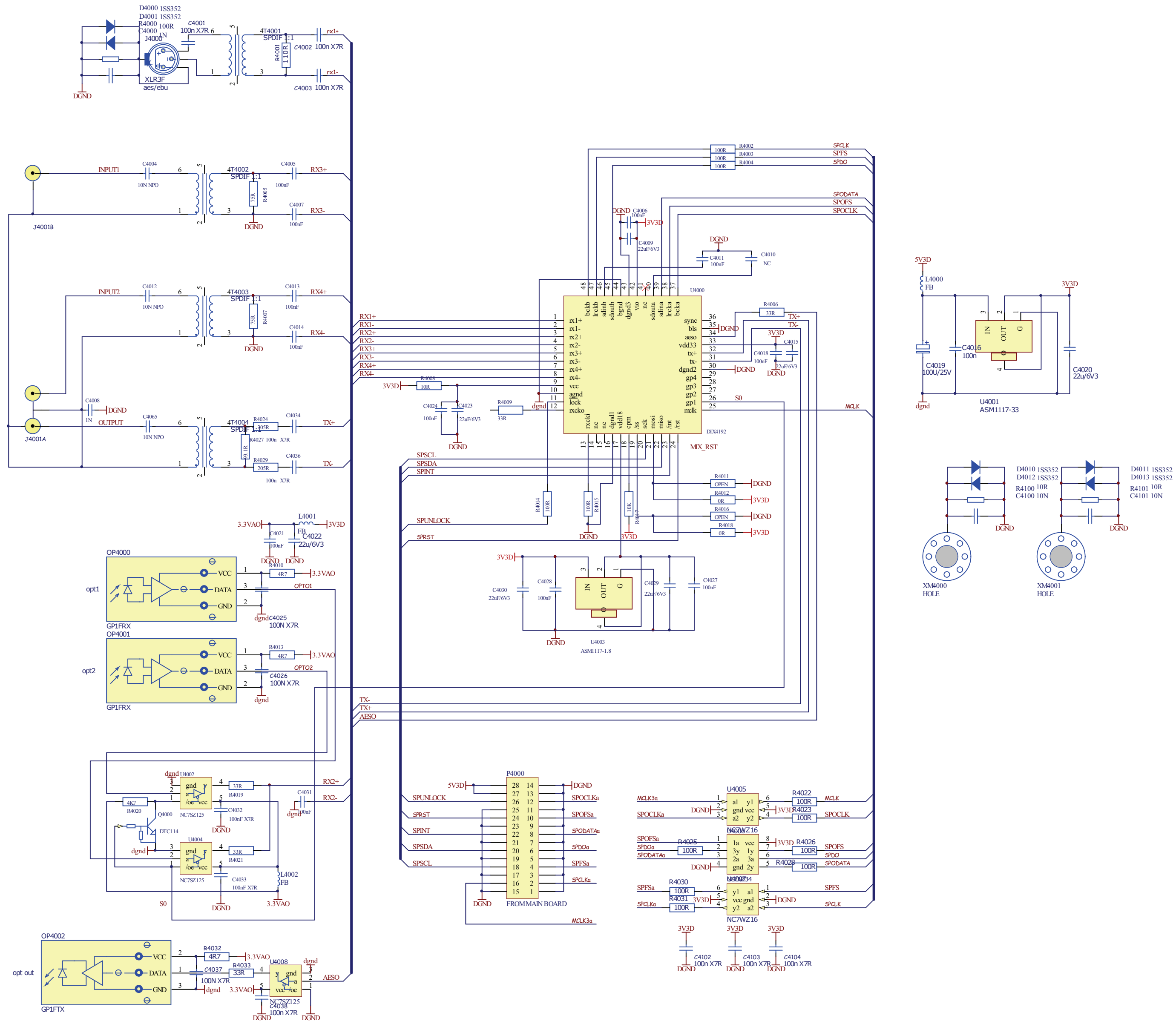

USB Board-1

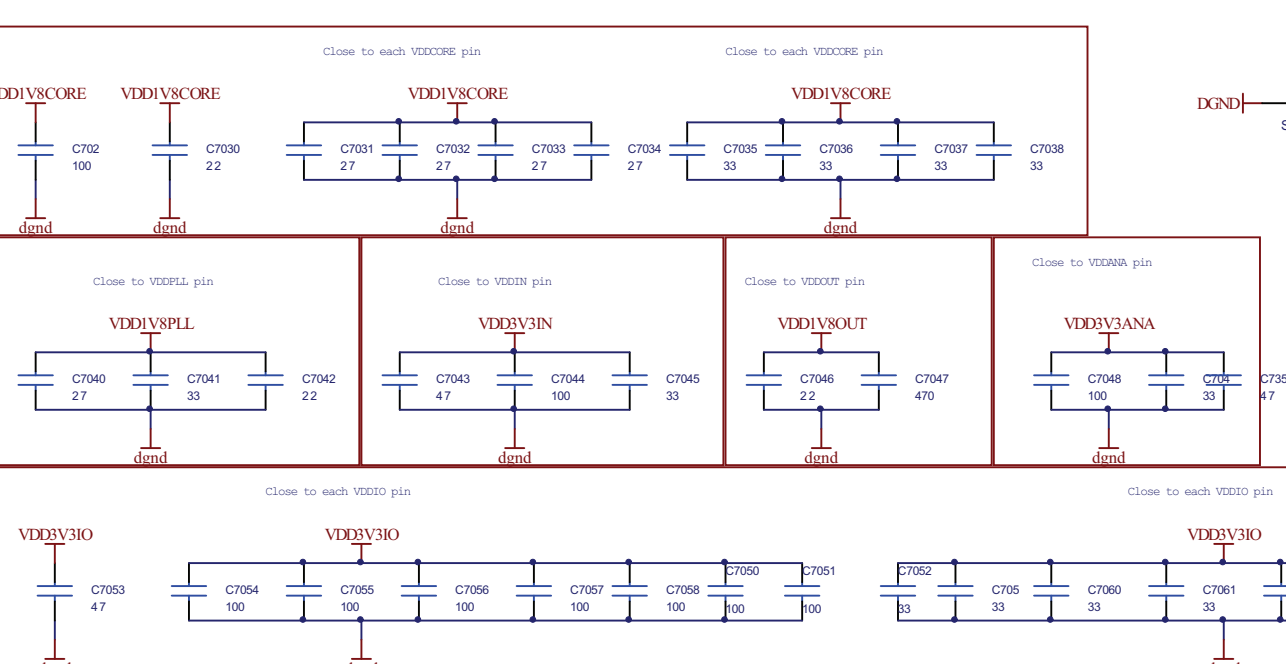
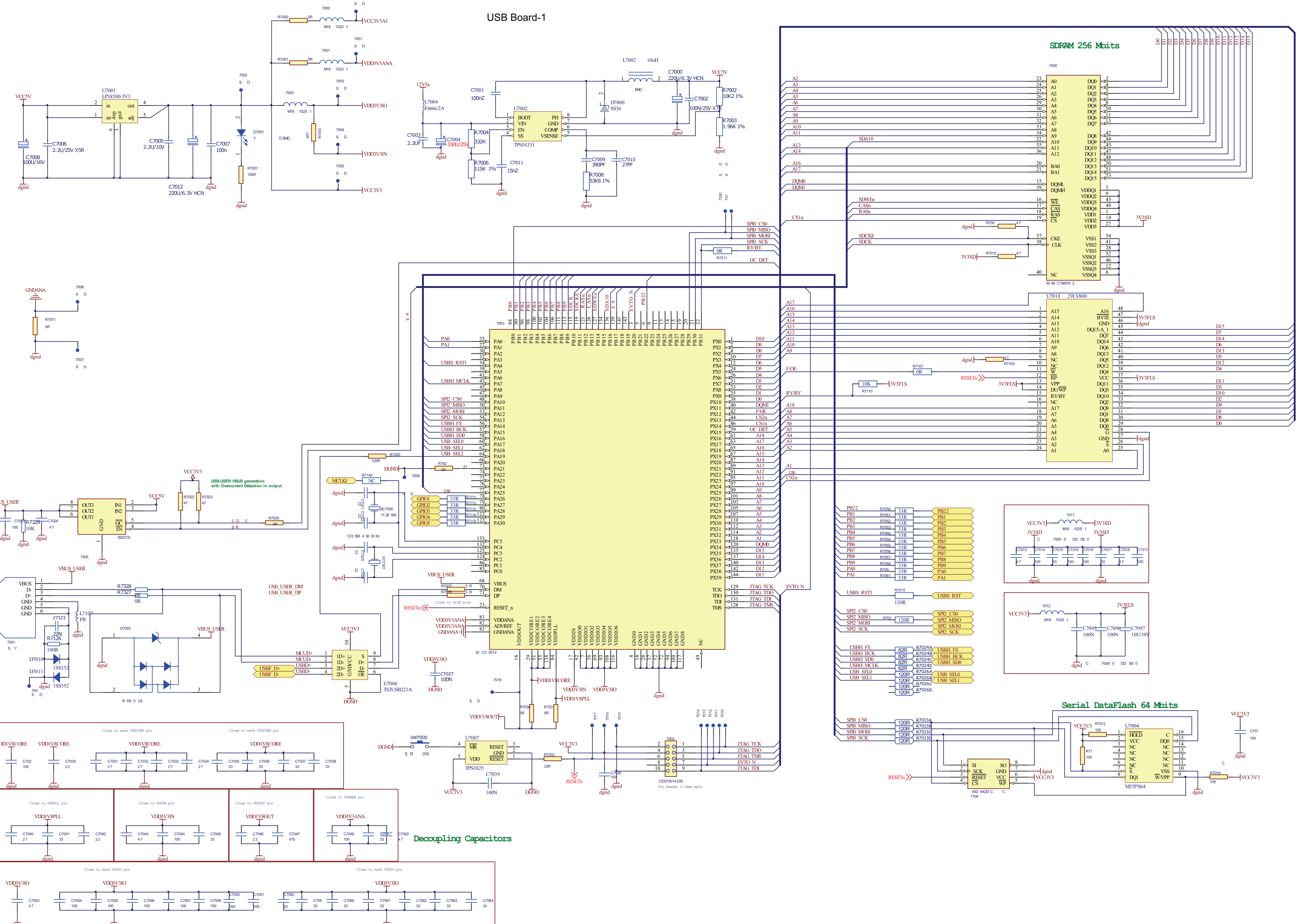

USB Board-2

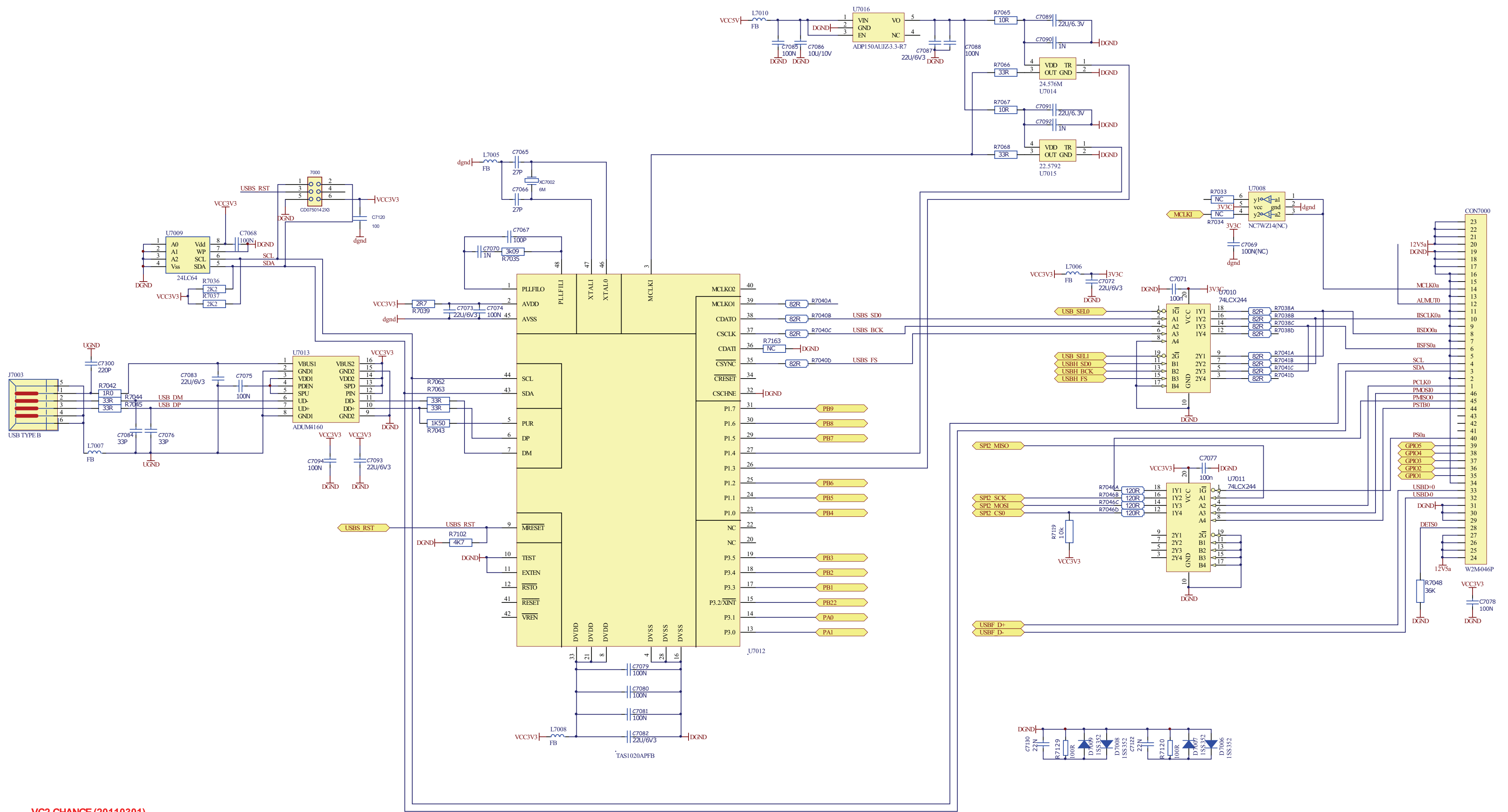

VC2 CHANGE (20110301)

1. change R7003 to 1.96K
2. change R7034 U7008 to NC,add xc7000 11.2896M,C7021 C7022 22p 0603
3. change U7001 to LP38500-3V3
4. change U7004 to M25P64,add R7102 100K 0603
5. Add U7018 29LV160BE-90, R7101 C7095 C7096 C7097 L7011 L7012
6. Add R7102 R7103 4.7K 0603 C7120 100N 0603 J1005 3X2PIN 2.54
7. change R7036 R7037 to 2K2

USB Board

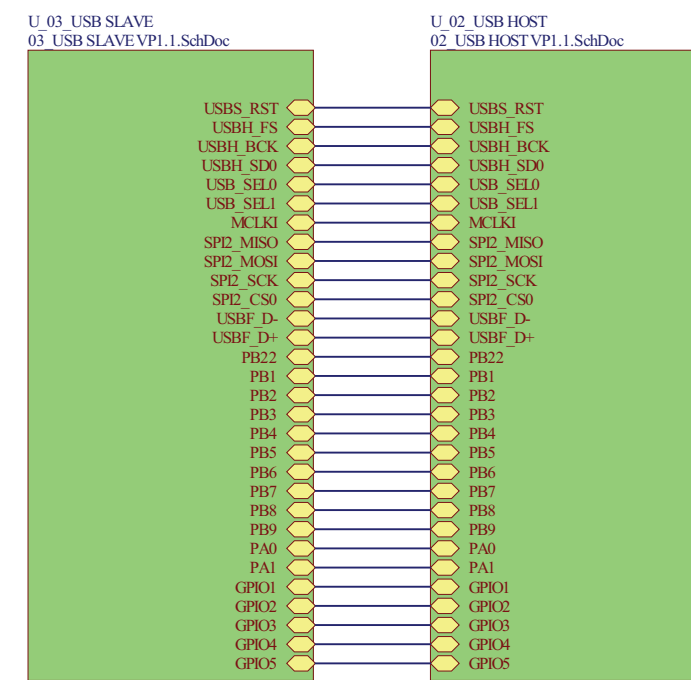

PSU-A Board

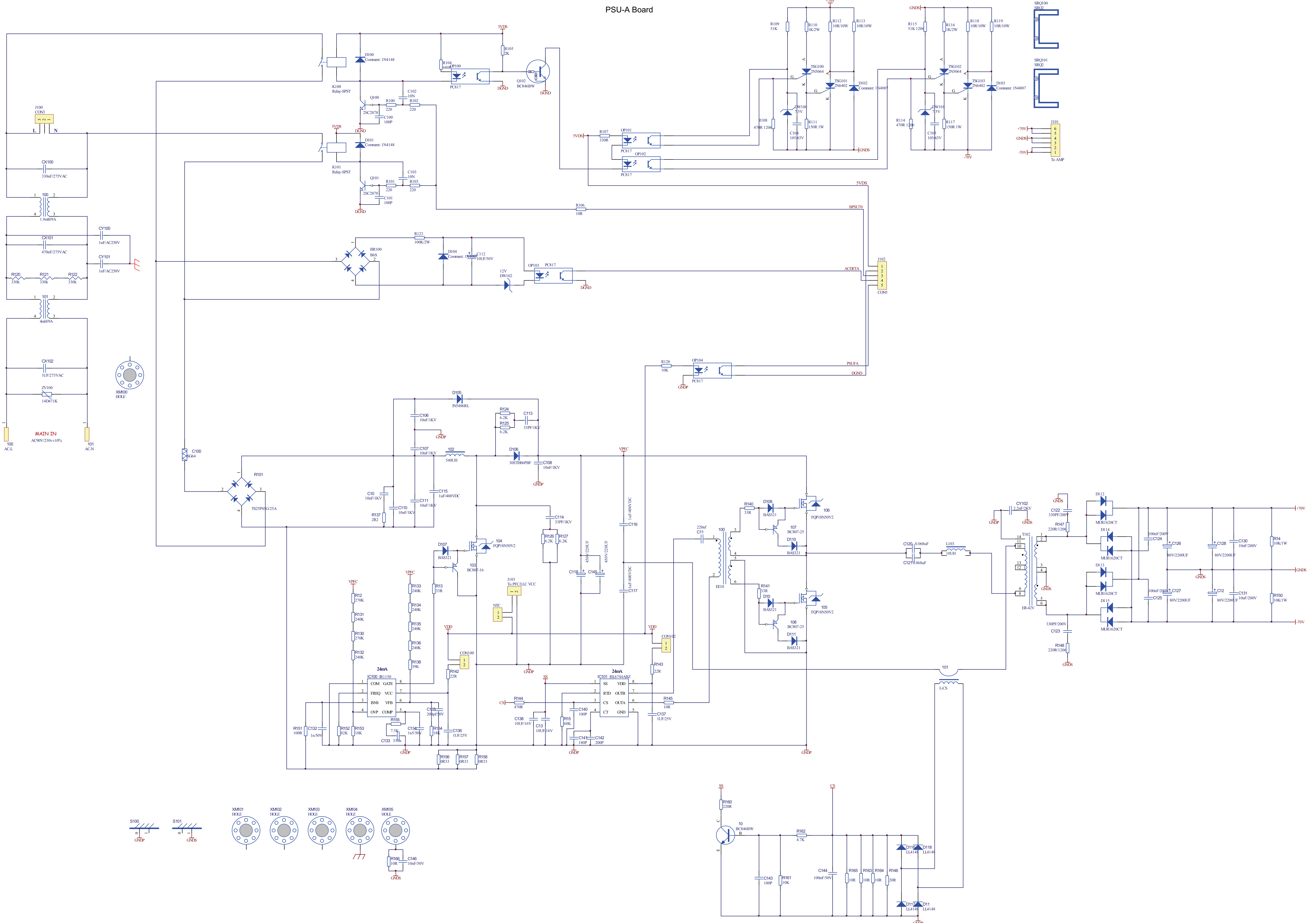

PSU-B Board

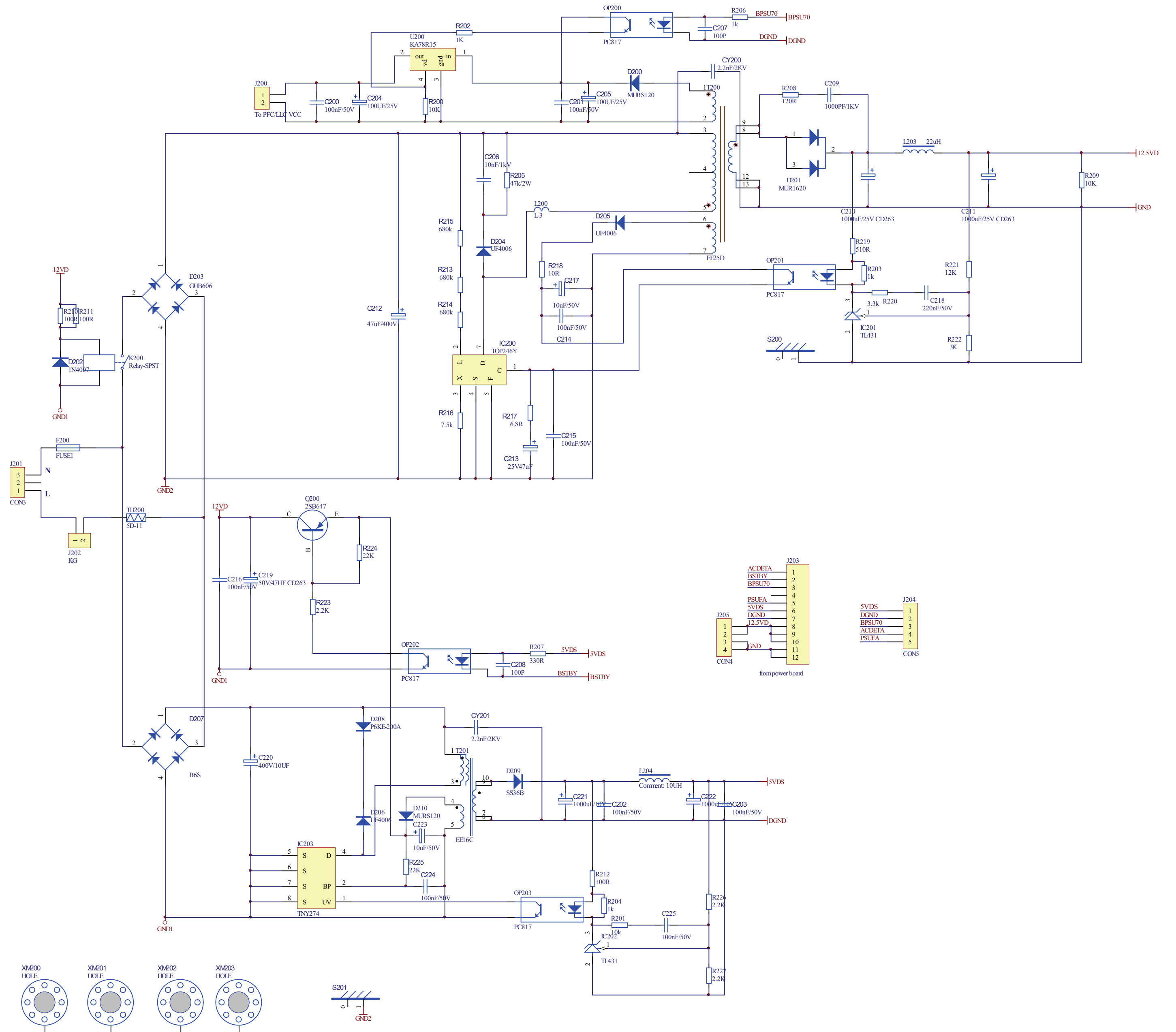

Phono Board

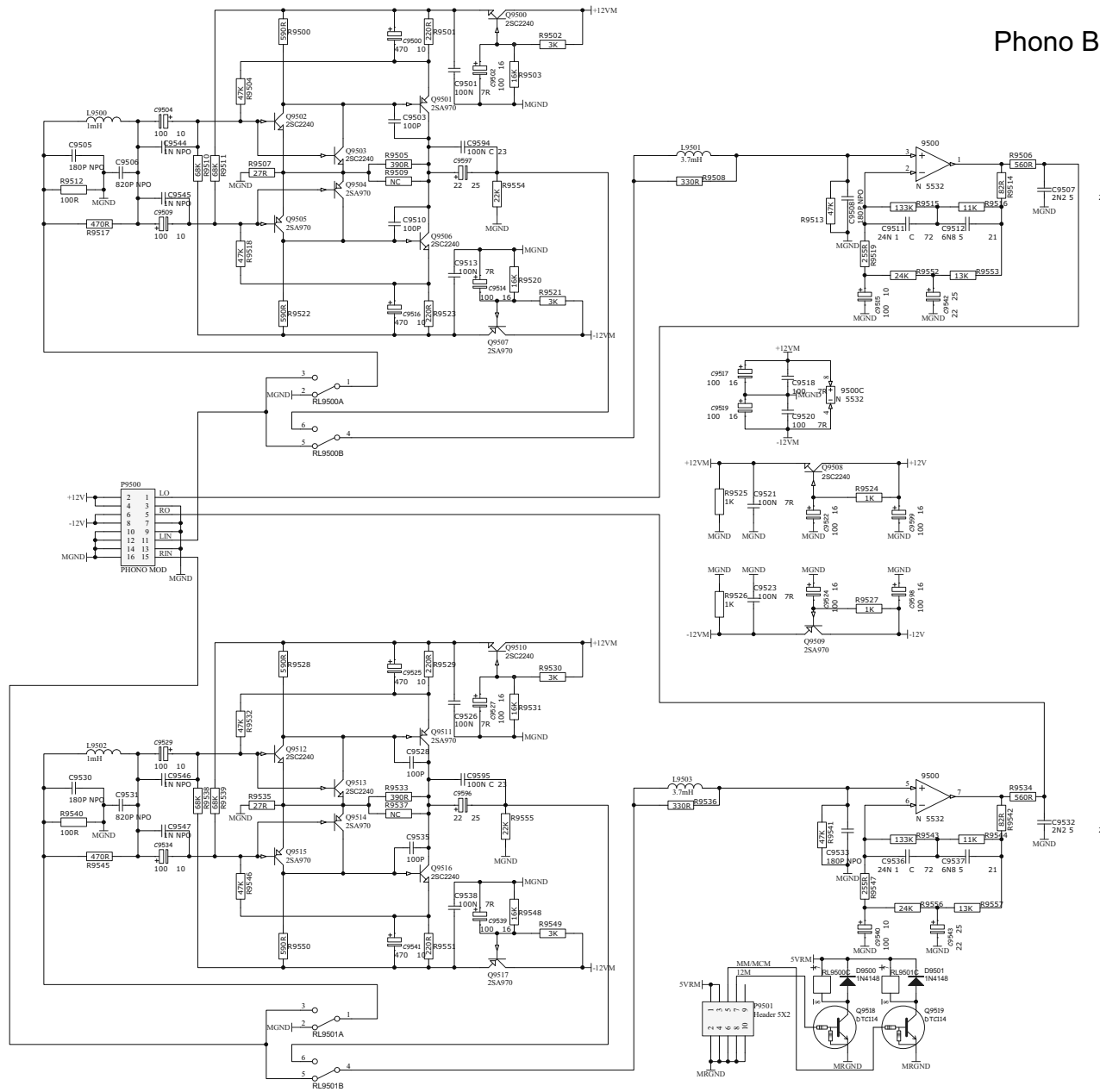

21

21

ALL 100U/10V 06-10111-28 UKW1A101MDDTA
 ALL 23V/25V 06-22021-08 UKW1H22MDDTD
 ALL 470U/10V 06-47111-15 UPW1A71MDDTD
 ALL 100U/15V 06-10111-25 EUF1C101H
 ALL 120k resistor Mett 1%
 ALL resistor 1%

EXPLODED VIEWS

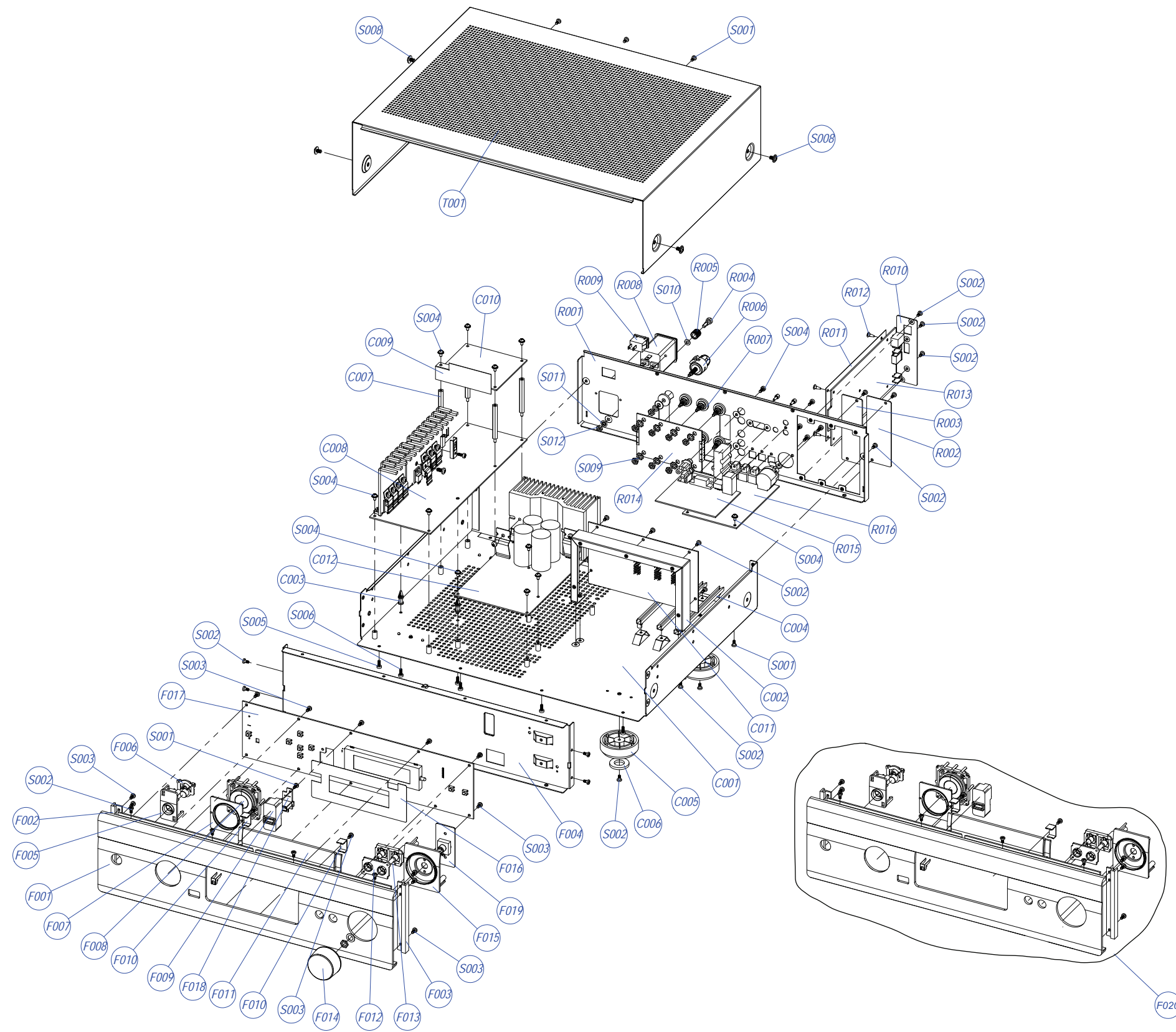

EXPLODED VIEW PARTS LIST

REF.NO	PART NO.	DESCRIPTION	Qty.	REF.NO	PART NO.	DESCRIPTION	Qty.
C001	67-230004-0	Chassis	1	R001	67-230001-1C	Rear Panel	1
C002	67-230008-0	Connector Bracket	1	R002	67-230010-0A	Audio Cover	1
C003	75-049001-0	Spacer Support	2	R003	67-230009-0A	HDMI Cover	1
C004	85-151002-0	PCB Guide	3	R004	71-003001-1	Grd.Post Bolt	1
C005	75-124001-0	Foot	4	R005	71-003002-0	Grd.Post Cap	1
C006	78-001002-0	Foot Pad	4	R006	17-03001-16	Binding Post(Red)	4
C007	69-112002-0	Copper Spacer	4	R007	17-03001-17	Binding Post(Black)	4
C008	01-39010-00	PSU Board A	1	R008	⚠️ A17-07103-26	AC Inlet	1
C009	78-230002-0	Insulation sheet	1	R009	⚠️ A11-01101-03	Rocker Switch	1
C010	01-39011-00	PSU Board B	1	R010	67-230007-0A	USB Fasica	1
C011	01-39001-00	Main Board	1	R011	76-230002-0	Insulation Pad	1
C012	01-39009-00	Powamp Board	1	R012	85-127002-0	Plastic Rivet	5
				R013	01-39007-00	USB Board	1
				R014	01-39002-00	SPK Board	1
F001	70-230002-1B	Fascia	1	R015	01-39005-00	INT Board	1
F002	70-230004-0	End Cap L	1	R016	01-39004-00	SPDIF Board	1
F003	70-230003-0	End Cap R	1				
F004	67-230003-0	Subfascia	1				
F005	77-230003-0	Power Button Bezel	1	T001	67-230002-0	Top Cover	1
F006	J71-124001-0	Power Button	1				
F007	77-230004-0	Cursor Frame Bezel	1				
F008	J71-230001-0	T747 Cursor	1	S001	61-022205-5	Self Tapping Screw BTB2.5x5	2
F009	77-230001-0	USB Bezel	1	S002	61-023106-0	Self Taping Screws STB3x6	36
F010	66-230001-0	Lens Bracket	3	S003	61-023206-0	Self Taping Screws BTB3x6	21
F011	76-230001-0	VFD Lens	1	S004	61-373506-0	Machine Screw M3x6	12
F012	77-223001-0	2P Input Button Bezel	1	S005	61-023108-0	Self Taping Screws STB3x8	4
F013	J71-124002-0	2P Input Button	1	S006	61-023208-0	Self Taping Screws BTB3x8	16
F014	J71-223001-0	Volume Knob	1	S007	61-073108-0	Self Taping Screws STO3x8	2
F015	77-230002-0	Volume Knob Bezel	1	S008	61-084108-0	Self Taping Screws STPW4X8	4
F016	75-230001-0	VFD Cover Sheet	1	S009	63-040506-1	Serrated Lock Washer	8
F017	01-39003-00	FPP Board	1	S010	63-010408-3	Plain Washer Ø4	1
F018	01-39013-00	Bootload Board	1	S011	63-040408-0	Spring Washer	1
F019	01-39014-00	Encode Board	1	S012	62-010402-0	Nut	1
F020	02-39099-00	Fascia Assembly Complete	1				

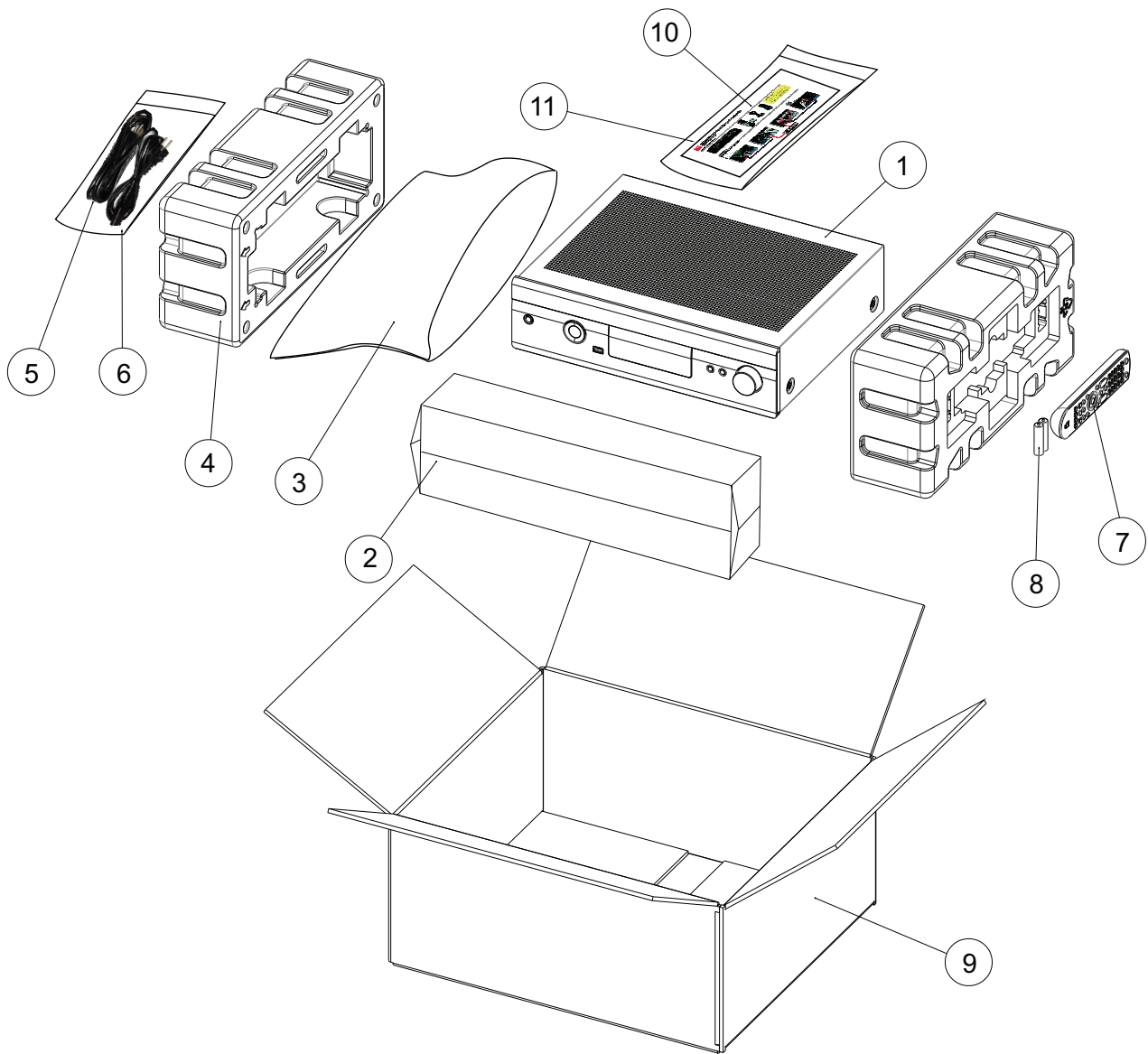

REF.N0	Part No.	Description	Qty.
1	00-39000-00	C390DD	1
2	90-019002-2	Non-Woven Cloth	1
3	90-005001-0	Polybag	1
4	89-230001-0	Polyfoam End Cap	2
5	JA15-16250-00 or A15-10230-20	C AC Cord	1
	JA15-15121-00 or A15-16251-00	AH AC Cord	1
6	90-001013-0	AC Cord Polybag	1
7	30-10390-00	Remote Control	1
8	30-22100-10	Batteries	2
9	88-230001-1A	Carton Box	1
10	30-40390-00	Quick start Gudiel	1
11	90-001002-0	Manual Polybag	1

SERVICE MANUAL

C390DD

Direct Digital Powered DAC/Amplifier