

C 422

**STEREO
AM/FM TUNER**

C 422

**STEREO
AM/FM TUNER**

SERVICE MANUAL

NAD

SERVICE SAFETY PRECAUTIONS

1. Safety check out

(Only U.S.A. model)

Before returning the product to the customer, make leakage current or resistance measurements to determine that exposed parts are acceptably insulated from the supply circuit.

Parts marked with the symbol \triangle are critical with regard to the risk of fire and electric shock. Replace only with parts recommended by the manufacturer.

CONTENTS

DESCRIPTION	PAGE
SPECIFICATIONS	3
REAR PANEL / FRONT PANEL	4
DISASSEMBLY INSTRUCTIONS	5
BLOCK DIAGRAM	6
WIRING DIAGRAM	7
ADJUSTMENT POINTS DIAGRAM	8
INSTRUMENT SETUP	9
ALIGNMENT PROCEDURES	10
PCB LAYOUT	11-12
SCHEMATIC DIAGRAM	13-14
IC BLOCK DIAGRAM	15-17
ELECTRICAL PARTS LIST	18-23
EXPLODED VIEW	24
EXPLODED VIEW PARTS LIST	25-26
PACKING DIAGRAM	27

SPECIFICATIONS

AM TUNER SECTION

Input level is expressed as the reading in open-circuit of 75-ohm source impedance signal generator

Usable Sensitivity (999/1000kHz)		≤30dBμ
S/N Ratio (5mV in)		≥38dB
THD (5mV in)		≤3%
IF Rejection (450kHz)		≥36dB
Image Rejection (F+2xIF)		≥28dB
Selectivity		≥17dB
Output		130 +/-20mV
Loop Sensitivity (20dB S/N)	999/1000 kHz	≤66 dB
	603/600 kHz	≤66 dB
	1404/1400 kHz	≤66 dB
Frequency response (100 - 2.3 kHz, 5mV)		±6 dB

FM TUNER SECTION

Input level is expressed as the reading in open-circuit of 75-ohm source impedance signal generator

		<u>*C</u>	<u>*AH</u>
Usable Sensitivity (98 MHz)		≤13 dBμ	≤13 dBμ
Signal / Noise Ratio	Mono	≥72 dB	≥72 dB
(60 dBμ, IHF wtd)	Stereo	≥66 dB	≥66 dB
Frequency Response (20 Hz - 15 kHz, 60 dBμ)		0±1.0 dB	0±1.0 dB
Channel Separation (60 dBμ)	30 Hz	≥33 dB	≥33 dB
	1 kHz	≥42 dB	≥42 dB
	10 kHz	≥32 dB	≥32 dB
Alternate Channel Sensitivity			
(40 dBμ, ±400 kHz)		≥60 dB	≥45 dB
Capture Ratio (40 dBμ)		≤3 dB	≤3 dB
AM Suppression			
(60 dBμ, 100% Mod.FM, 30% Mod AM)		≥65 dB	≥65 dB
Image Rejection (119.4 MHz)		≥85 dB	≥85 dB
I.F. Rejection (10.7 MHz)		≥78 dB	≥78 dB
Pilot Suppression (60 dBμ)		≥60 dB	≥60 dB
THD (60 dBμ, L=R 75 kHz for AH, 40 kHz Dev for C)			
	Mono	≤0.25%	≤0.25%
	Stereo	≤0.35%	≤0.35%
Auto-Search sensitivity	On	≥24 dBμ	≥24 dBμ
	Off	≤15 dBμ	≤15 dBμ
RDS Decode Sensitivity		≤26 dBμ	≤26 dBμ

PHYSICAL SPECIFICATIONS

Dimensions (Width x Height x Depth)	435 x 80 x 285 mm
Net weight	4 kg (8.8 lbs)
Shipping weight	5.1 kg (11.22 lbs)

REAR PANEL / FRONT PANEL

REAR PANEL

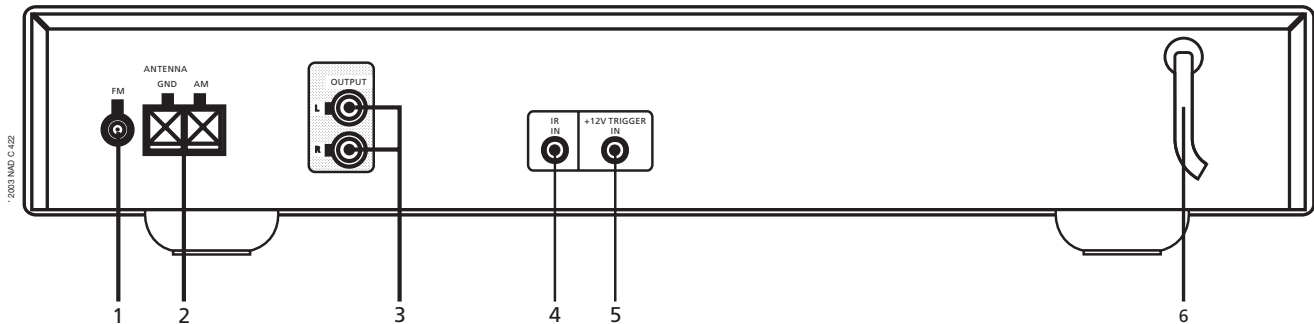

- | | |
|---------------|-------------------|
| 1. FM ANTENNA | 4. IR IN |
| 2. AM ANTENNA | 5. 12V TRIGGER IN |
| 3. OUTPUT | 6. AC LINE CORD |

FRONT PANEL

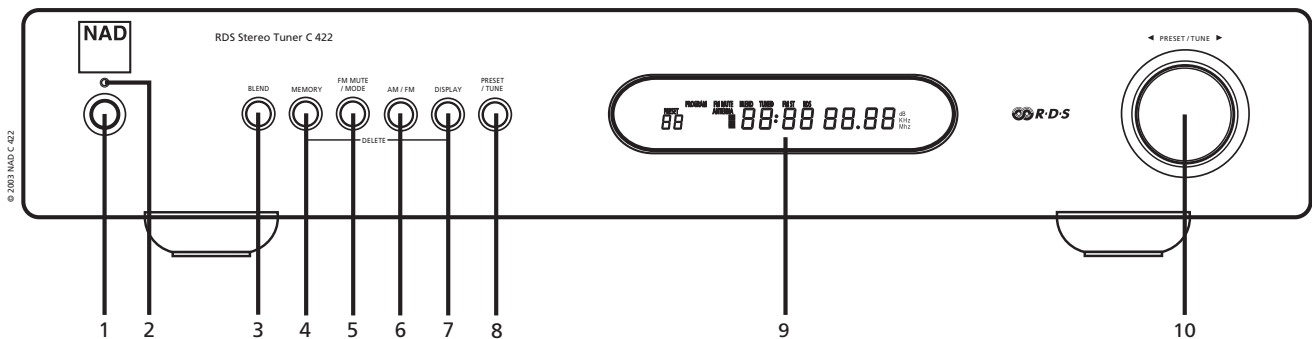

- | | |
|---------------------------|---------------------------|
| 1. POWER ON / OFF | 6. AM / FM |
| 2. POWER STATUS INDICATOR | 7. DISPLAY |
| 3. BLEND | 8. PRESET / TUNE |
| 4. MEMORY | 9. DISPLAY AREA |
| 5. FM MUTE / MODE | 10. PRESET / TUNE CONTROL |

IMPORTANT NOTES

1. Show the software version

Press "PRESET/TUNE" and "TUNE UP" (▶).

2. Light UP all the icon on the VFL

Press "PRESET/TUNE" and "TUNE DOWN" (◀).

3. CPU Resets

Press "PRESET/TUNE" and "TUNE DOWN" (◀) and any one key.

4. AM Step 10K/9K Change

Add D206: 10KHz / Delete D206: 9KHz.

DISASSEMBLY INSTRUCTIONS

1. Remove machine screws M 4.0 x 6.0 (① to ④) from the side panels.
Remove tapping screw 3.0 x 8.5 (⑤) from the back panel.
Refer to **Figure No.1**.

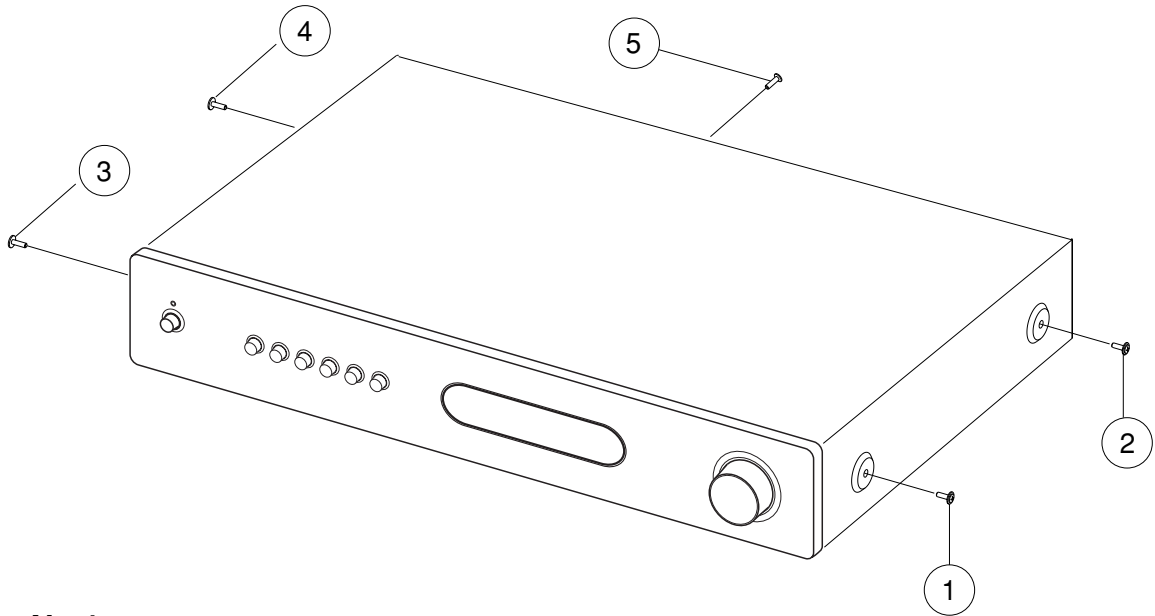

Figure No.1

2. Pull both sides of the TOP COVER slightly outwards (⑥) and tilt approx. 35° and then remove in the direction as indicated by the arrow (⑦). Refer to **Figure No.2**.

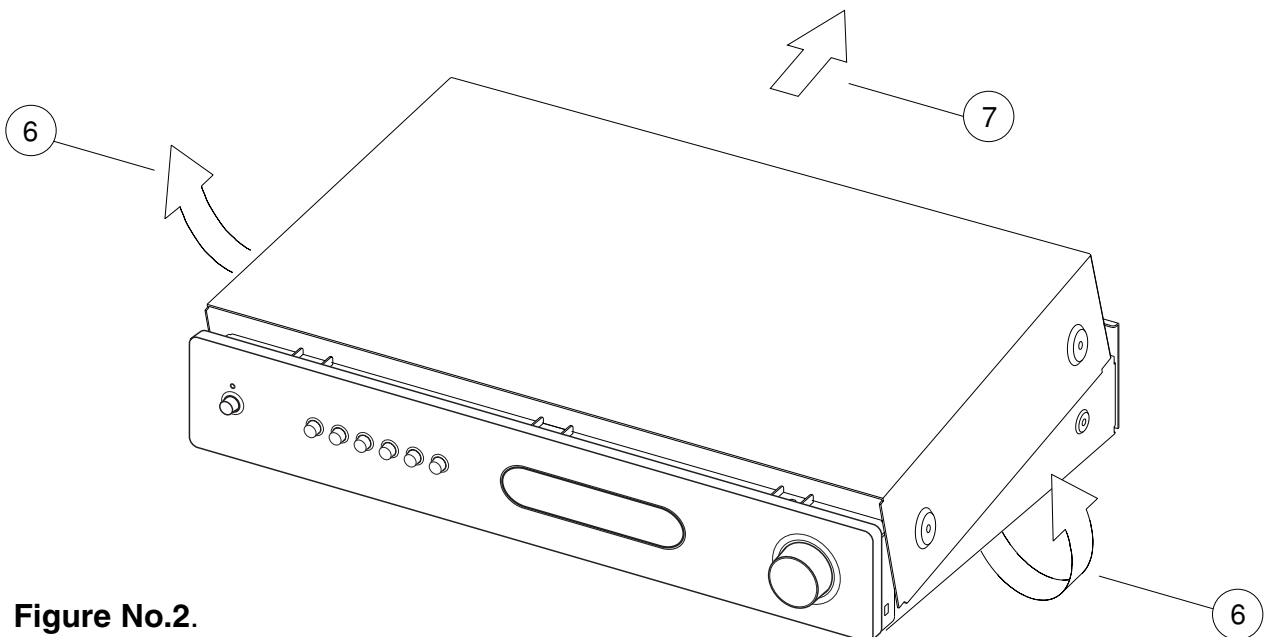
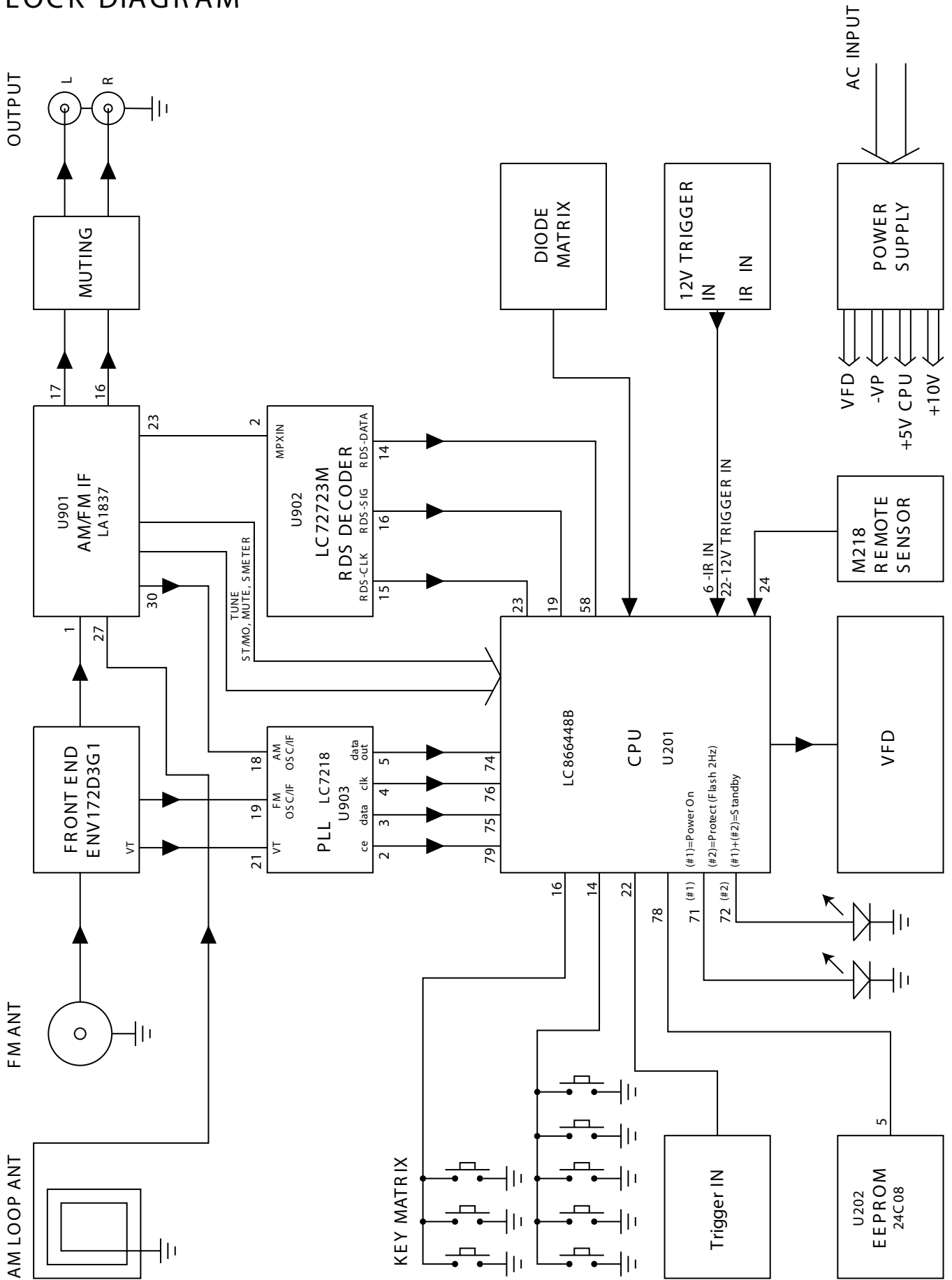

Figure No.2.

BLOCK DIAGRAM



INSTRUMENT SETUP

1. FM MEASUREMENT

Fig. 1

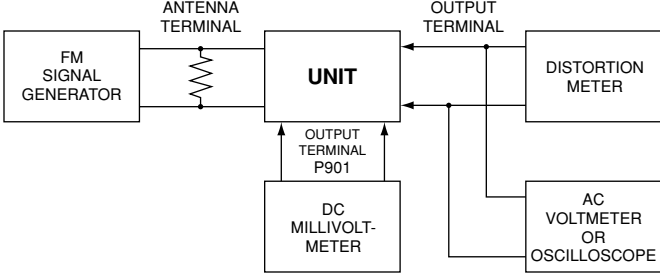
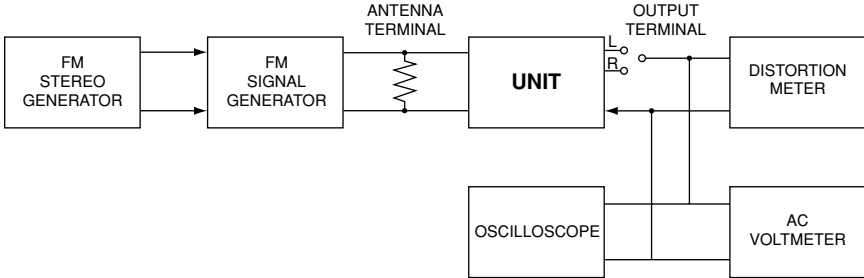
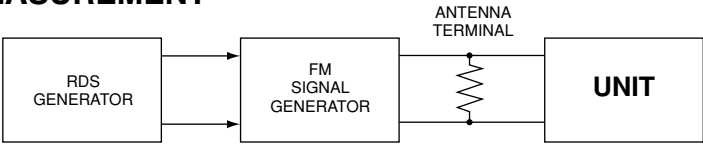

Fig. 2



2. RDS MEASUREMENT

Fig. 3



3. AM MEASUREMENT

Fig. 4

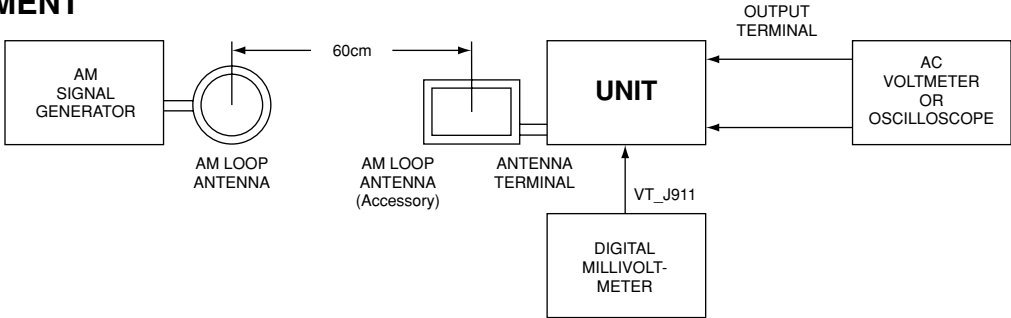

ALIGNMENT PROCEDURES

FM/RDS SECTION

- FM mono: 1kHz, 75kHz devi., 60dB/μV
- FM stereo: 1kHz, 67.5kHz devi., 60dB/μV
Pilot signal 19kHz 7.5kHz devi.

OUTPUTS

- Connect the 47Kohm resistor unless otherwise noted.

Item	Step	Connection of instrument	FM SG output	Stereo modulator output	Tuning frequency	Output indicator	Adjustment point	Adjust for	Remarks
FM IF/RF	1	Fig.1	99.0MHz 1kHz 75kHz devi. 65dBf (60dB)	-	99.0MHz	DC voltmeter	L941	0±70mV	FM MUTE/MODE switch: ON/AUTO Repeat the steps 1 to 3 until no further adjustment is necessary.
	2					AC voltmeter	IFT on the front end	Maximum	
	3					Distortion analyzer	L942	Minimum	
Stereo Distortion		Fig.2	99.0MHz Ext. mod. 65dBf (60dB)	Channel L or R 1kHz	99.0MHz	Distortion analyzer	IFT on the front end	Minimum	FM MUTE/MODE switch: ON/AUTO Don't turn more than ±180°
Stereo Separation		Fig.2	99.0MHz Ext. mod. 65dBf (60dB)	Channel L or R 1kHz	99.0MHz	Oscilloscope	R941	Maximum separation	Repeat stereo distortion and stereo separation alignment until THD at minimum and separation at maximum.
						Distortion Meter		Minimum	
Mute Level		Fig.1	99.0MHz 18dB	-	99.0MHz	Oscilloscope	R956	Signal output	
RDS		Fig.3	99.0MHz Ext. mod. 65dBf (60dB) RDS 2% MOD	-	99.0MHz	-	-	-	Decode the RDS-Program station

AM SECTION

AF Modulation: 400Hz, 30%

For AH Version

Step	AM SG output	Tuning frequency	Output indicator	Adjustment point	Adjust for
1	-	530kHz	Digital DC voltmeter	OSC coil on RF block M971	1.35±0.2V
2	600kHz 400Hz 30% mod. 60dB/m	600kHz	AC voltmeter	RF coil on RF block M971	Maximum
3	600kHz 400Hz 30% mod. 60dB/m	990kHz	AC voltmeter	L972	Maximum

For C Version

Step	AM SG output	Tuning frequency	Output indicator	Adjustment point	Adjust for
1	-	522kHz or 531kHz	Digital DC voltmeter	OSC coil on RF block M971	1.3±0.2V (522kHz) 1.35±0.2V (531kHz)
2	600kHz 400Hz 30% mod. 60dB/m	603kHz	AC voltmeter	RF coil on RF block M971	Maximum
3	600kHz 400Hz 30% mod. 60dB/m	999kHz	AC voltmeter	L972	Maximum

PCB LAYOUT

POWER SUPPLY BOARD

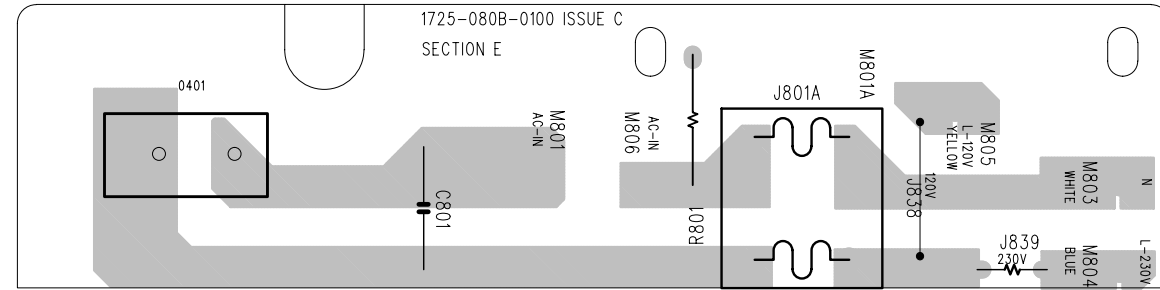

LED BOARD

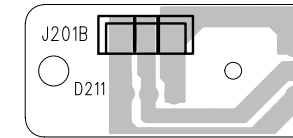

KEY BOARD

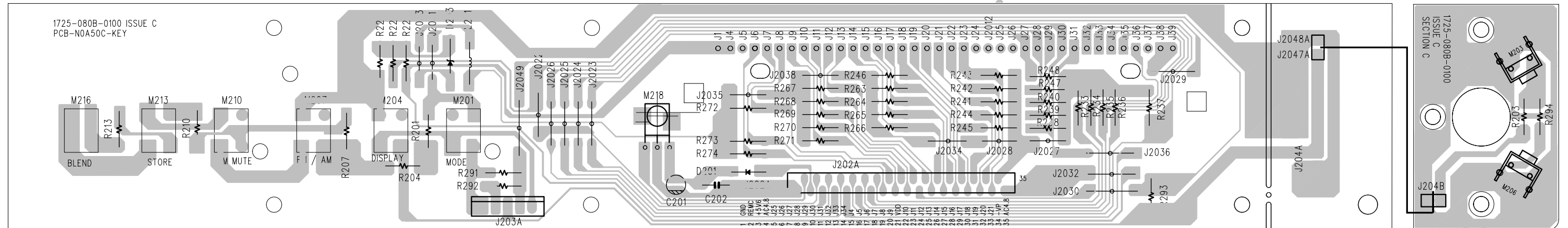

MAIN BOARD

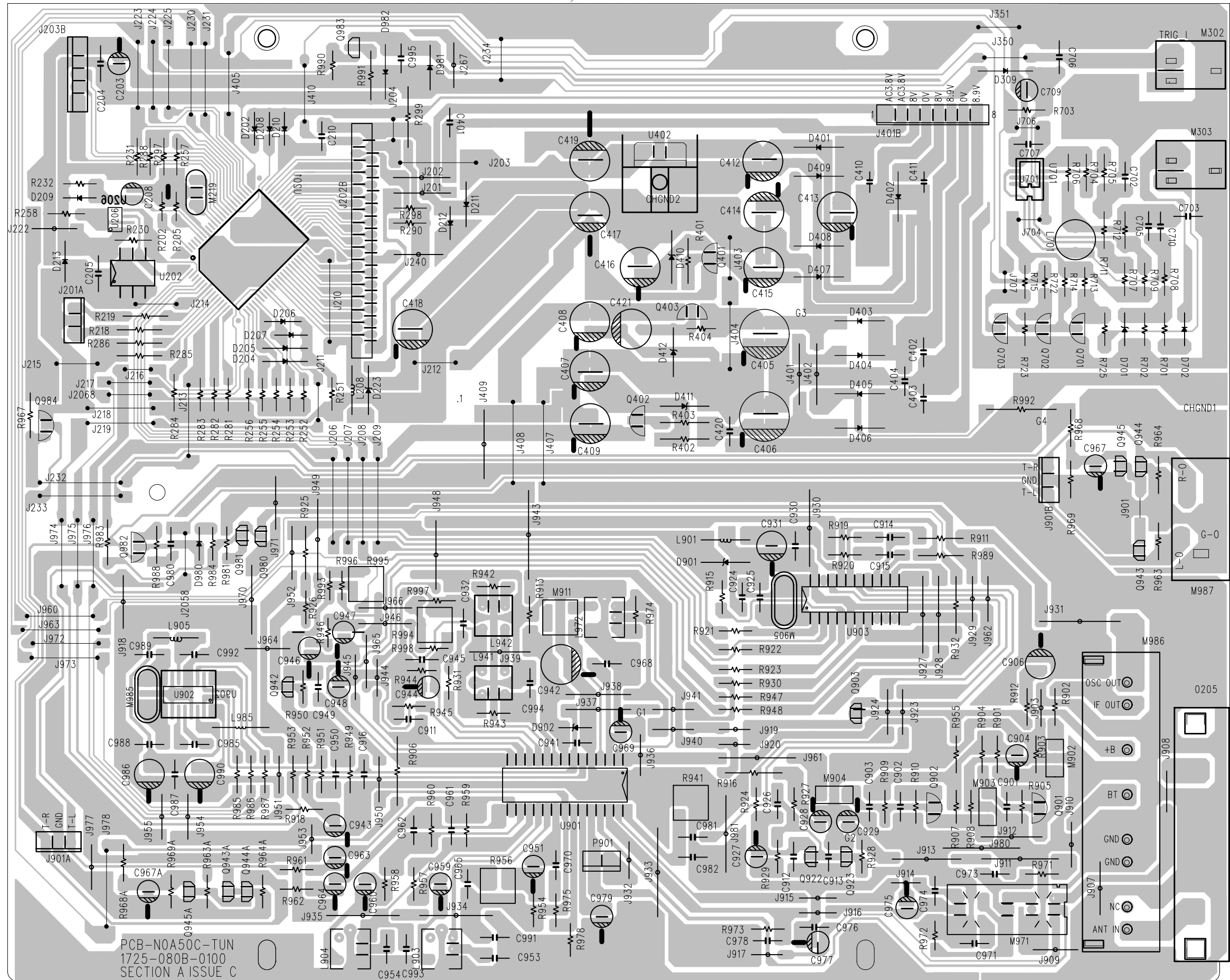

SCHEMATIC DIAGRAM

KEYBOARD / DISPLAY

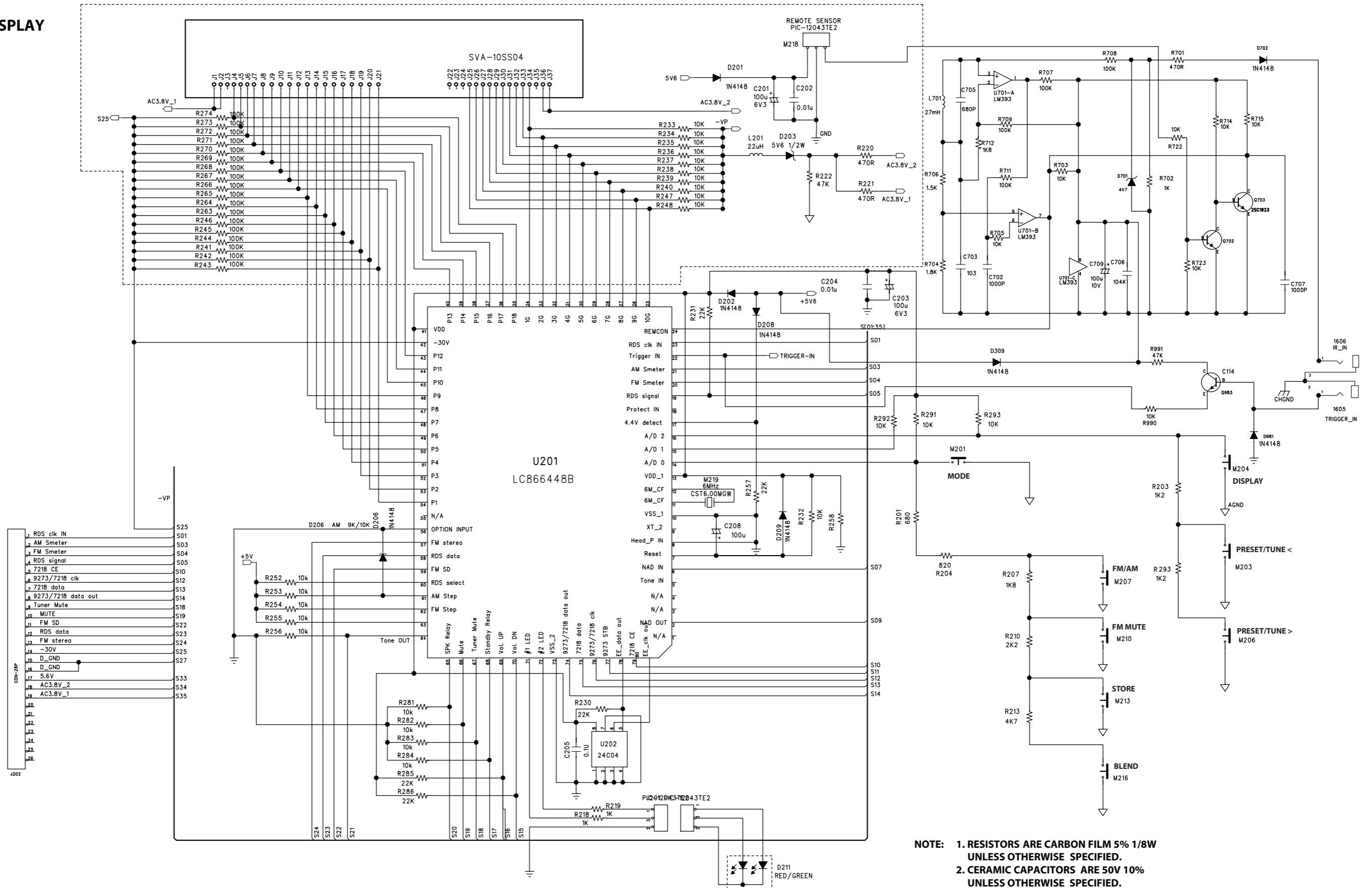

TUNER

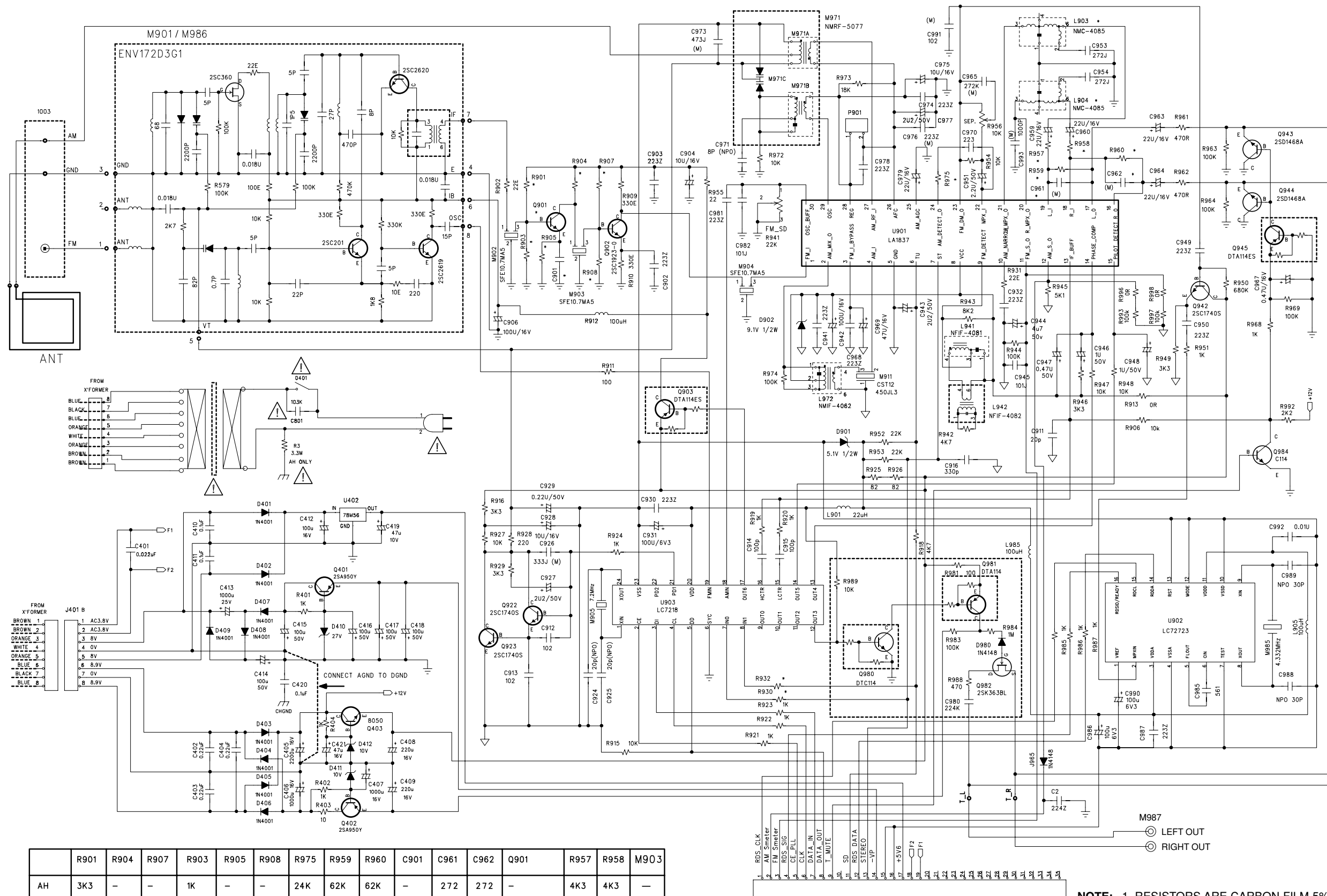

IC BLOCK DIAGRAM

U201: LC866448B

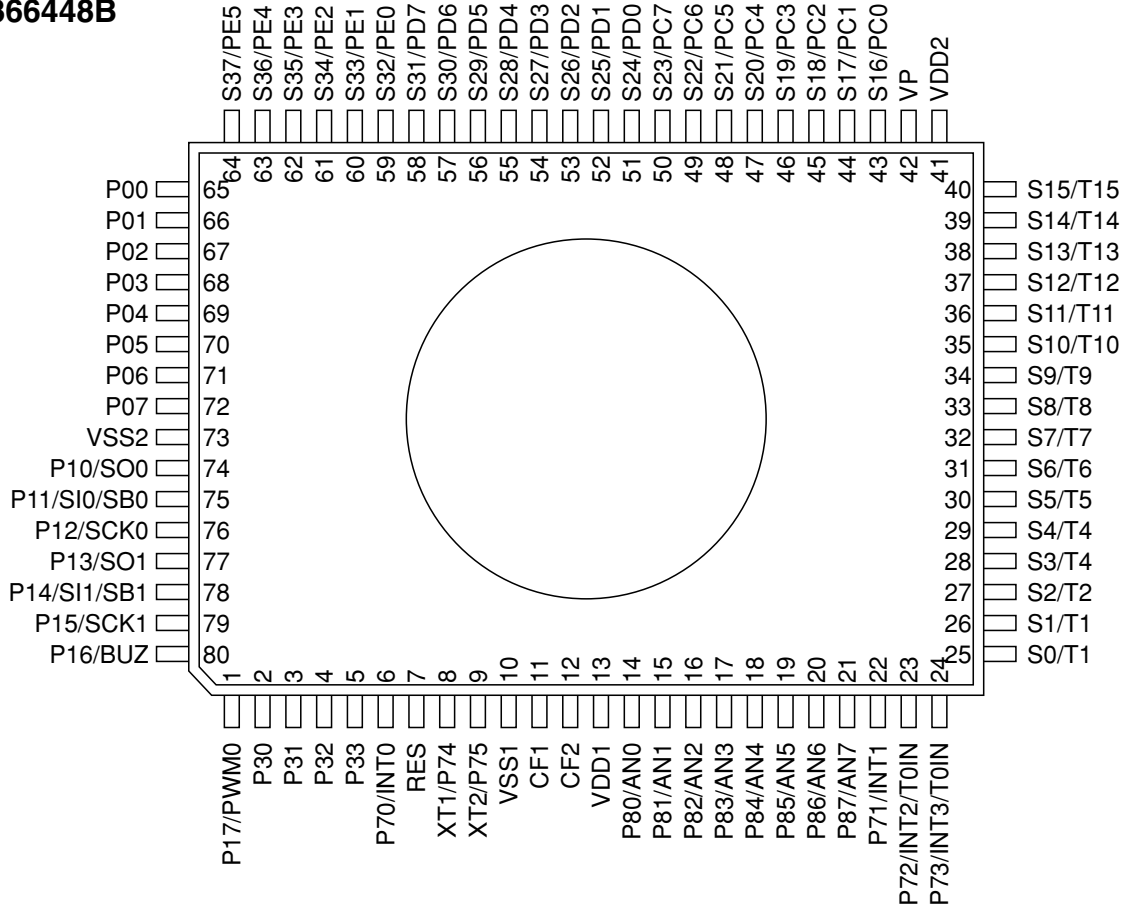

U202: 24C08

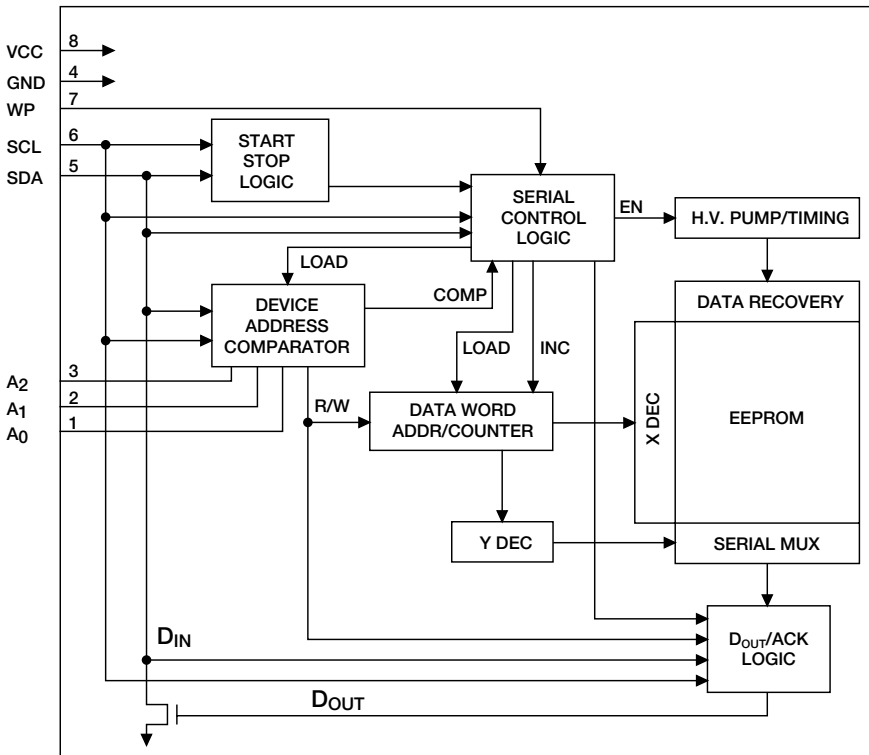

U402: NJM78M56FA

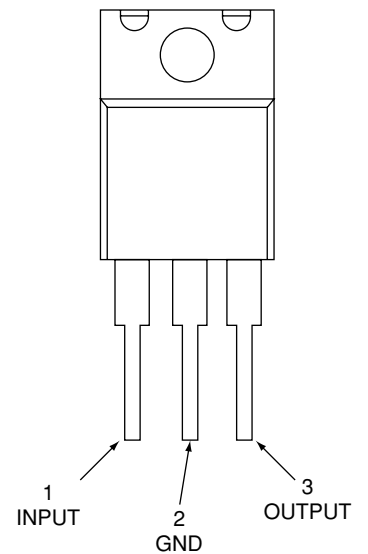

U701: LM393D

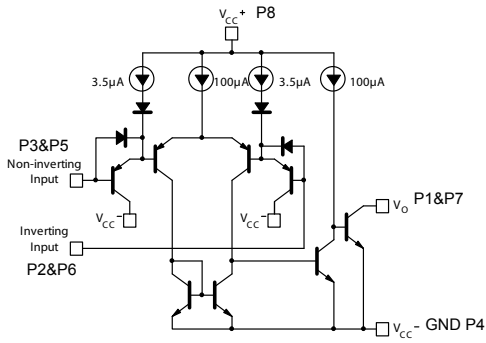

Dual-In-Line/SOIC Package

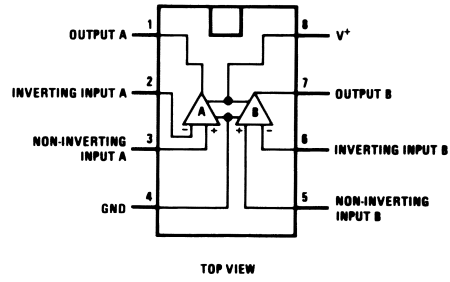

U901: LA1837

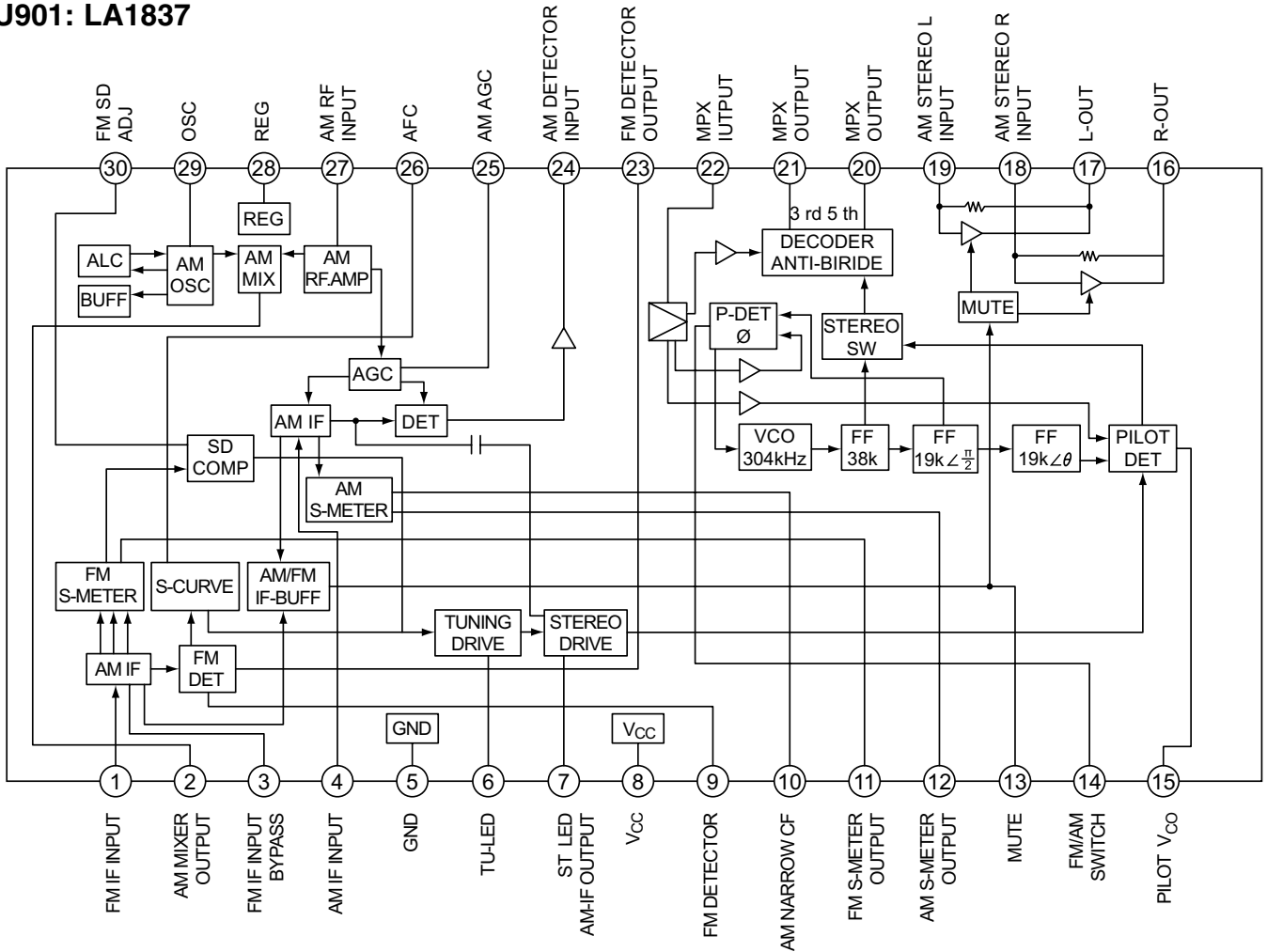

U902: LC72723M

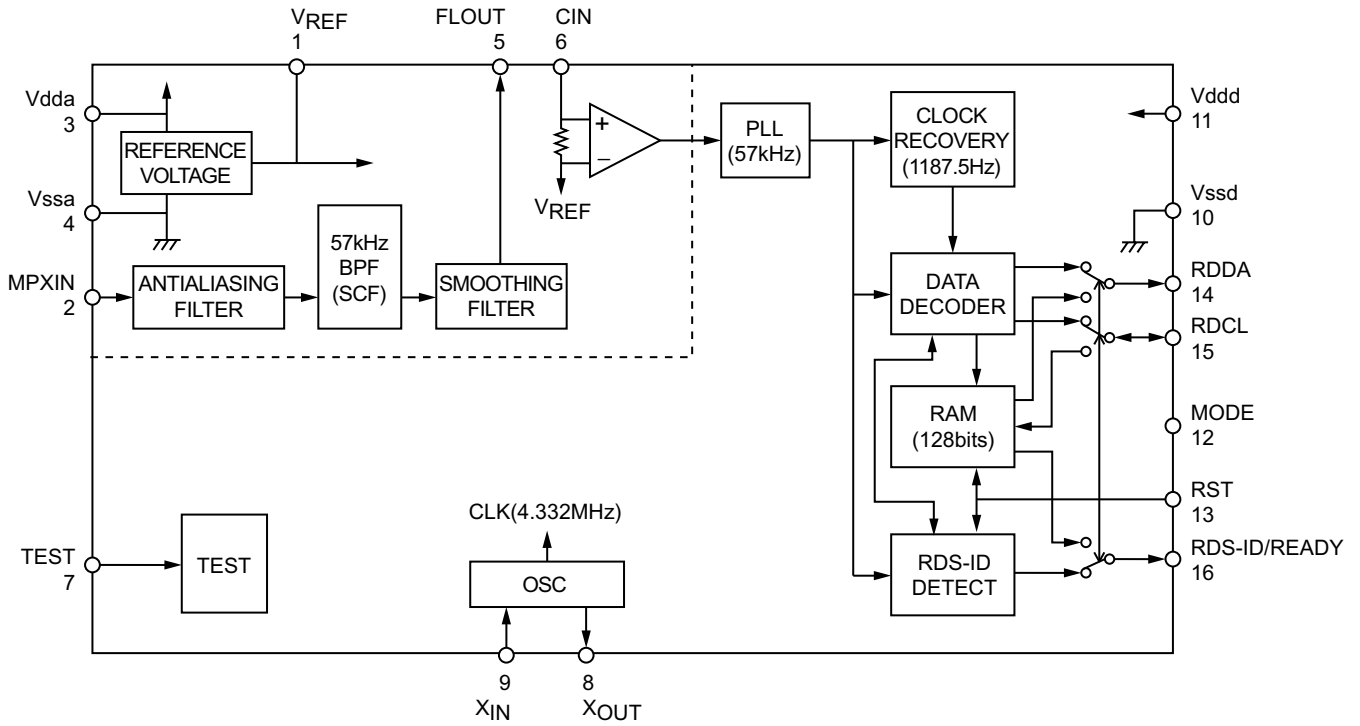

U903: LC7218

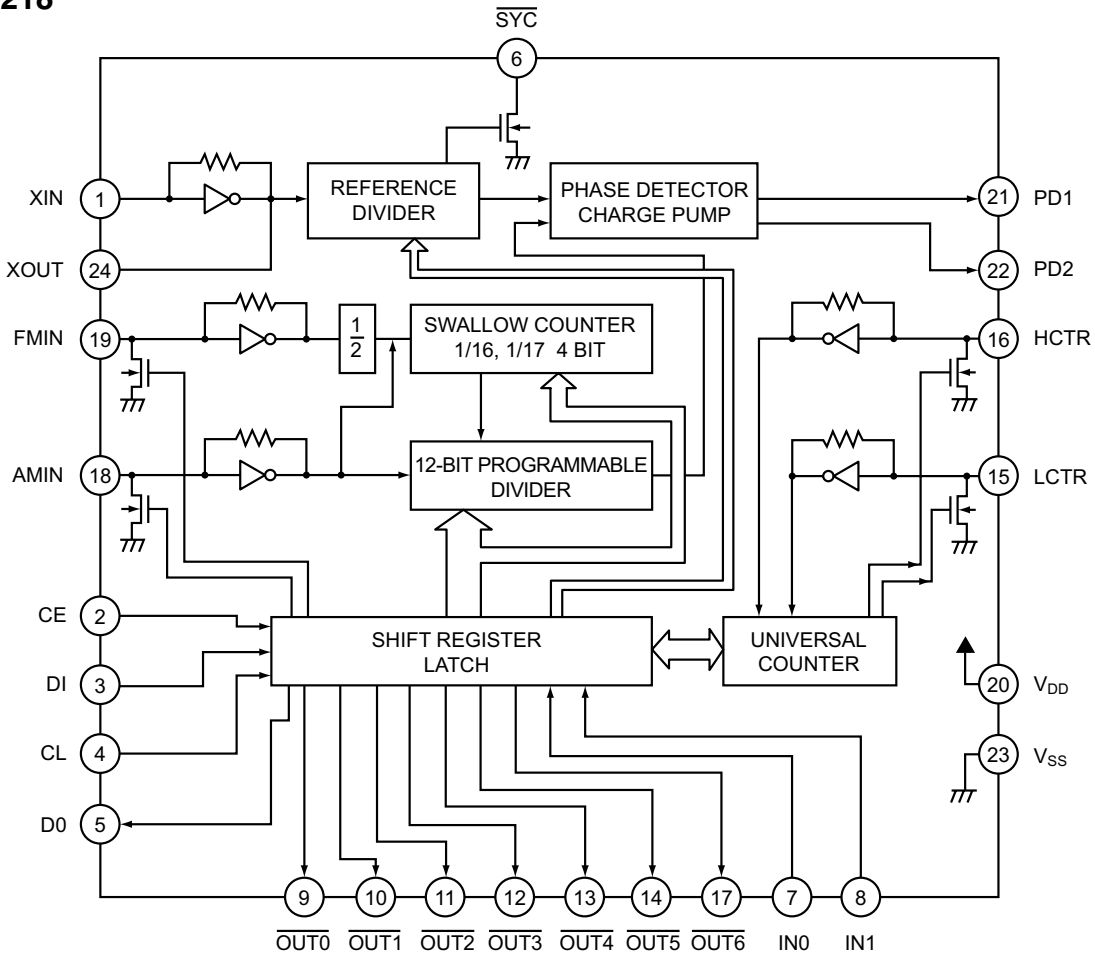

ELECTRICAL PARTS LIST

Reference No.	Part No.	Description
KEY ASSY PC BOARD	PCB-N0A50C-KEY	PCB ASSY KEY N0A50C
CAPACITOR C201 C202	157B-107M-5-KMK 153F-103J-5-KM	CE 6.3V 100 μ F 20% RL CM 50V 0.01 μ F 5% RL
COIL L201	1801-220K-M	COIL 22 μ H 10% AL BL7
WAFER/CONNECTOR J202A J204B	2101-1581-0 2102-021R-004	FLEXIBLE CONN. 35P WAFER 2P P2.5 RIGHT
RESISTOR R201 R203,R204,R294 R207 R210 R213 R220,R221 R222 R233-R240,R247,R248,R291-R293 R241-R246,R263-R272	4701-681J-2 4701-122J-2 4701-182J-2 4701-222J-2 4701-472J-2 4701-471J-2 4701-473J-2 4701-103J-2 4701-104J-2	RCF 1/8W 680R 5% AT RCF 1/8W 1.2K 5% AT RCF 1/8W 1.8K 5% AT RCF 1/8W 2.2K 5% AT RCF 1/8W 4.7K 5% AT RCF 1/8W 470R 5% AT RCF 1/8W 47K 5% AT RCF 1/8W 10K 5% AT RCF 1/8W 100K 5% AT
DIODE D201 D203	4804-1480-C 4837-5B61-2	DIODE 1N4148 ATS DZ 1/2W 5.45-5.73 ROHM
SWITCH M201,M204,M207,M210,M213,M216 M203,M206	5200-3538-0 5200-4721-0	SWITCH, TACT SKHHBY 7MM TACT SWITCH (RIGHT)
WIRE J203A J204A	7705-1150-2004 7702-1075-2004	5P CONN WIRE ASSY L=150 CONN.ASSY 2P P2.5 L=75
PC BOARD 0300	1725-080B-0100	PCB MAIN/KEY/VFD N0A50C
MISCELLANEOUS 0302 0303	4154-2101-0 2460-1960-0	VFD HOLDER VFD, SAMSUNG,HNA-10SM12

Reference No.	Part No.	Description
M218	4814-3TE2-3	IR SENSOR PIC-12043TE2
<u>LED ASSY</u> PC BOARD		
	PCB-N0A50C-LED	PCB ASSY LED N0A50C
LED		
D211	3700-3517-RG	LED RED/GREEN (L-469HW)
WIRE		
J201B	7703-1320-2004	3P CONN WIRE ASSY L=320
PC BOARD		
	1725-080B-0100	PCB MAIN/KEY/VFD N0A50C
<u>PSU ASSY</u> PC BOARD		
*AH	PCB-N0A50C-PSU	PCB ASSY PSU N0A50C
*CE	PCB-N0A51C-PSU	PCB ASSY PSU N0A51C
CAPACITOR		
C801 ▲	8910-0049-0	CAP400V 4700P
RESISTOR		
R801 *AH	4717-335J-2-S	RMF 1/2W 3.3M 5% AT UL
SWITCH		
0401 ▲	5200-3151-0-01	POWER SWITCH
PC BOARD		
0400	1725-080B-0100	PCB MAIN/KEY/VFD N0A50C
MISCELLANEOUS		
M801,M803-M806	4132-1071-0	TERMINAL PIN
<u>TUN ASSY</u> PC BOARD		
*AH	PCB-N0A50C-TUN	PCB ASSY TUN N0A50C
*CE	PCB-N0A51C-TUN	PCB ASSY TUN N0A51C
CAPACITOR		
C203	157B-107M-5-KMK	CE 6.3V 100µF 20% RL 6x7
C204,C210	153F-103J-5-IM	CM 50V 0.01µF 5% RL 5X7
C205	150F-104Z-5-IU	CC 50V 0.1µF +80/-20% RL 5x11
C208	157D-476M-5-IUK	CE 16V 47µF 20% RL 5X11

Reference No.	Part No.	Description
C401,C402,C403,C404	153F-224J-5-MIB	CM 50V 0.22μF 5% RL 7x5
C405	157D-228M-5-X9E	CE 16V 2200μF 20% RL 12.5x20
C406,C407	157D-108M-5-S9K	CE 16V 1000μF 20% RL 10x20
C408,C409	157D-227M-5-OMK	CE 16V 220μF 20% RL 8x7
C410,C411,C420,C706	150F-104K-5-II	CC 50V 0.1μF 10% RL 5x5
C412,C414,C906,C942	157D-107M-5-KUK	CE 16V 100μF 20% RL 6x11
C413,C421	157E-108M-5-S9E	CE 25V 1000μF 20% RL 10X20
C415	157F-107M-5-OW	CE 50V 100μF 20% RL 8x12
C416,C417,C418	157F-107M-5-OVK	CE 50V 100μF 20% RL 8x11.5
C419	157C-476M-5-IMK	CE 10V 47μF 20% RL 5X7
C702,C707	153F-102J-5-IM	CM 50V 1000PF 5% RL 5x7
C703	150F-103K-5-II	CC 50V 0.01μF 10% RL 5x5
C705	150F-681J-5-OI	CC 50V 680PF 5% RL 8X5
C709	157C-107M-5-IU	CE 10V 100μF 20% RL 5x11
C901 *CE	150F-223K-2-FD	CC 50V 0.022μF 10% AT
C902,C903,C930,C932,C941,C949, C950,C968,C970,C974,C976,C978, C981,C987	150F-223K-2-FD	CC 50V 0.022μF 10% AT
C904,C928,C975	157D-106M-5-GM	CE 16V 10μF 20% RL 4x7
C911	150F-200J-2-FC	CC 50V 20pF 5% AT 3.5x2
C912,C913	150F-102K-2-FC	CC 50V 1000pF 10% AT 3.5x2
C914,C915,C945,C982	150F-101K-2-FC	CC 50V 100pF 10% AT 3.5x2
C916	150F-331K-2-FC	CC 50V 330pF 10% AT 3.5x2
C924	15CH-270J-5-GG	CTC 0/60 27pF 5% RL 4x4
C925	15CH-200J-5-GG	CTC 0/60 20pF 5% RL 4x4
C926	153F-333J-5-NLM	CM 50V 0.033μF 5% RL 7.5
C927,C943,C977	157F-225M-5-GM	CE 50V 2.2μF 20% RL 4x7
C929	157F-224M-5-GM	CE 50V 0.22μF 20% RL 4x7
C931,C986,C990	157B-107M-5-KM	CE 6.3V 100μF 20% RL 6x7
C944	157F-475M-5-GM	CE 50V 4.7μF 20% RL 4x7
C946,C948	157F-105M-5-GM	CE 50V 1μF 20% RL 4x7
C947	157F-474M-5-GM	CE 50V 0.47μF 20% RL 4x7
C951	157E-475M-5-GME	CE 25V 4.7μF 20% RL 4X7
C953,C954,C965	150D-272K-2-FC	CC 16V 2700pF 10% AT 3.5x2
C959,C960,C963,C964,C979	157D-226M-5-GM	CE 16V 22μF 20% RL 4X7
C961,C962 *CE	153F-152J-5-KW	CM 50V 1500pF 5% RL 6x12
C961,C962 *AH	153F-272J-5-JM	CM 50V 2700PF 5% RL 5.5x7
C967	157D-474M-5-II	CE 16V 0.47μF 20% RL 5x5
C969	157D-476M-5-IM	CE 16V 47μF 20% RL 5X7
C971	15CH-080D-5-GG	CTC 0/60 8pF 0.5pF RL 4x4
C973	153F-473J-5-NLM	CM 50V 0.047μF 5% RL 7.5x6.5
C980	153F-152J-5-KW	CM 50V 1500pF 5% RL 6x12
C985	150F-561K-2-FC	CC 50V 560pF 10% AT 3.5x2
C988,C989	15CH-300J-5-IG	CTC 0/60 30pF 5% RL 5x4
C991	15CG-102J-7-IJ	CTC 0/30 1000pF 5% RM 5x5.5
C992	150F-103K-2-FC	CC 50V 0.01μF 10% AT 3.5x2
R995	150F-224M-N-II	CC 50V 0.22μF 20% RLF MO

Reference No.	Part No.	Description
TUNER M901	1300-0726-0	TUNER ENV172D3G1
COIL L701 L901 L905,L985,R912	1807-273J-PS 1801-220K-M 1801-101K-M	COIL 27MH 5% 8.3X9.7 COIL 22μH 10% AL BL7 COIL 100μH 10%
WAFER/CONNCECTOR 0205 *AH 0205 *CE J201A J202B J203B J401B	2107-0641-0 2107-0681-0 2102-031S-004 2101-1591-0 2102-051S-004 2102-081S-004	ANT-TERMINAL F-TYPE ANT-TERMINAL (DIN-TYPE) 3 PIN ST. WAFER FLEXIBLE CONN. 35P P1.25 5P ST.WAFER WAFER 8P P2.5 ST.
JACK 0204 M302,M303 P901	2113-1300-0 2113-1179-0 2113-1160-0	2P RCA JACK W/R AU PHONE JACK D3.5 BK WAFER 2P ST. P=2.5 NH
CRYSTAL M905 M985	2300-0440-0 2300-1220-0	CRYSTAL 7.2MHZ 20PPM CRYSTAL 4.332MHZ
CERAMIC FILTER M902,M904 M903 *CE M911	2701-0010-1 2701-0010-1 2701-0680-0	CF10.7 +-30 CF10.7 +-30 CF 450 +-1
IC U201 U202 U402 U701 U901 U902 U903	3131-9750-1 3131-7250-0 3130-8190-0 3130-4990-0 3130-8180-0 3131-9040-0 3131-3760-0	IC LC866448B 8 BIT IC 24C08 8K EEPROM IC NJM78M56FA 5.6V IC LM393D DUAL VOLTAGE IC LA1837 AM/FM IF IC LC72723M RDS IC LC7218 PLL FREQ
RESISTOR R201,R205,R297,R918,R942,R992 R218,R219,R401,R402,R404,R702, R903,R916,R919,R920,R923,R924, R951,R968,R985-R987 R230,R231,R257,R267,R285,R286, R952,R953	4701-472J-2 4701-102J-2 4701-223J-2	RCF 1/8W 4.7K 5% AT RCF 1/8W 1K 5% AT RCF 1/8W 22K 5% AT

Reference No.	Part No.	Description
R232,R253-R256,R281-R284,R703, R705,R707,R714,R715,R722,R723, R906,R915,R927,R947,R948,R954, R972,R989,R991	4701-103J-2	RCF 1/8W 10K 5% AT
R403	4701-100J-2	RCF 1/8W 10R 5% AT
R701,R961,R962,R988	4701-471J-2	RCF 1/8W 470R 5% AT
R704,R712	4701-182J-2	RCF 1/8W 1.8K 5% AT
R706	4701-152J-2	RCF 1/8W 1.5K 5% AT
R708,R711,R944,R963,R964,R969, R974,R983,R993,R997	4701-104J-2	RCF 1/8W 100K 5% AT
R709,R943	4701-822J-2	RCF 1/8W 8.2K 5% AT
R901 *CE	4701-333J-2	RCF 1/8W 33K 5% AT
R902,R931,R955	4701-220J-2	RCF 1/8W 22R 5% AT
R903 *CE	4701-123J-2	RCF 1/8W 12K 5% AT
R905 *CE	4701-681J-2	RCF 1/8W 680R 5% AT
R907,R946,R949	4701-332J-2	RCF 1/8W 3.3K 5% AT
R909,R910	4701-331J-2	RCF 1/8W 330R 5% AT
R911,R981	4701-101J-2	RCF 1/8W 100R 5% AT
R921,R922,R929	4701-222J-2	RCF 1/8W 2.2K 5% AT
R925,R926	4701-820J-2	RCF 1/8W 82R 5% AT
R928	4701-221J-2	RCF 1/8W 220R 5% AT
R945	4701-512J-2	RCF 1/8W 5.1K 5% AT
R950	4701-684J-2	RCF 1/8W 680K 5% AT
R957,R958 *CE	4701-302J-2	RCF 1/8W 3K 5% AT
R957,R958 *AH	4701-432J-2	RCF 1/8W 4.3K 5% AT
R959,R960 *CE	4701-154J-2	RCF 1/8W 150K 5% AT
R959,R960 *AH	4701-623J-2	RCF 1/8W 62K 5% AT
R973	4701-183J-2	RCF 1/8W 18K 5% AT
R975 *AH	4701-243J-2	RCF 1/8W 24K 5% AT
R975 *CE	4701-563J-2	RCF 1/8W 56K 5% AT
R978,R984	4701-105J-2	RCF 1/8W 1M 5% AT
R990	4701-473J-2	RCF 1/8W 47K 5% AT
SVR		
R941	4756-2236-3-06	SVR 22K H3 7X7.6 RH0615C
R956	4756-1036-3-06	SVR 10K H3 7X7.6 RH0615C
DIODE		
D202,D206,D208,D209,D211,D213, D309,D980,D981,J965	4804-1480-C	DIODE 1N4148 ATS
D401-D409	4804-0010-2	DIODE 1N4001 AT
D410	4837-27V0-2	DZ 1/2W 27V(26.2-27.6)AT
D411,D412	4837-10D1-2	DZ 1/2W 9.94~10.44V ROHM
D701	4837-4B71-2	DZ 1/2W 4.55~4.80V ROHM
D901	4837-4C20-2	DZ 1/2W 5.0-5.2V AT
D902	4837-7C20-2	DZ 1/2W 9.1-9.5V AT
J213	4837-3V36-2	DZ 1/2W +-5% 3.3V TEMIC



Reference No.	Part No.	Description
TRANSISTOR		
Q401,Q402	485A-950Y-5	TR 2SA950-Y HFE 100-200
Q403	4860-0050-5	TR SS8050 C/D SAMSUNG RL
Q702,Q703,Q902	4851-9230-5	TR 2SC1923-0 HFE 70-140
Q901 *CE	485C-945P-5	TR 2SC945P HFE 200-400
Q903,Q945,Q981	485A-114E-5	TR DTA114ESA ROHM
Q922,Q923,Q942	4860-1590-5	TR 2SC1740S
Q943,Q944	4860-8120-G	TR 2SD1468S TPS ROHM
Q980,Q983,Q984	485C-114E-5	TR DTC114ES
Q982	4853-63BL-5	TR N-JEET 2SK-363BL
PC BOARD		
	1725-080B-0100	PCB MAIN/KEY/VFD N0A50C
MISCELLANEOUS		
L903,L904	5600-3386-S	COIL MPX LPF NMC-4085
L941	5600-3396-S	COIL FM DET-1 10.7MHZ
L942	5600-3406-S	COIL FM DET-2 10.7MHZ
L971	5600-3280-G	COIL MW RF BLOCK
L972	5600-3416-S	COIL AM IFT NMIF-4062
M219	2703-0200-0	CR 6MHZ CSTLA6M00G55-A0
R801A *AH	4132-1061-0	SOLDER TAG
TUNER	4131-7701-0	ANTENNA WASHER

- NOTE:**
- The components identified by \triangle mark are critical for risk of fire and electrical shock. Replace only with part number specified.
 - <*AH > : USA, Canadian model only.
 - <*C > : European model only.
 - Capacitors : CP-Polystyrene, CM-Mylar, CE-Electrolytic, CC-Ceramic, CTC-NPO.
 - Resistors : RMF-Metal Film, RCF-Carbon Film.

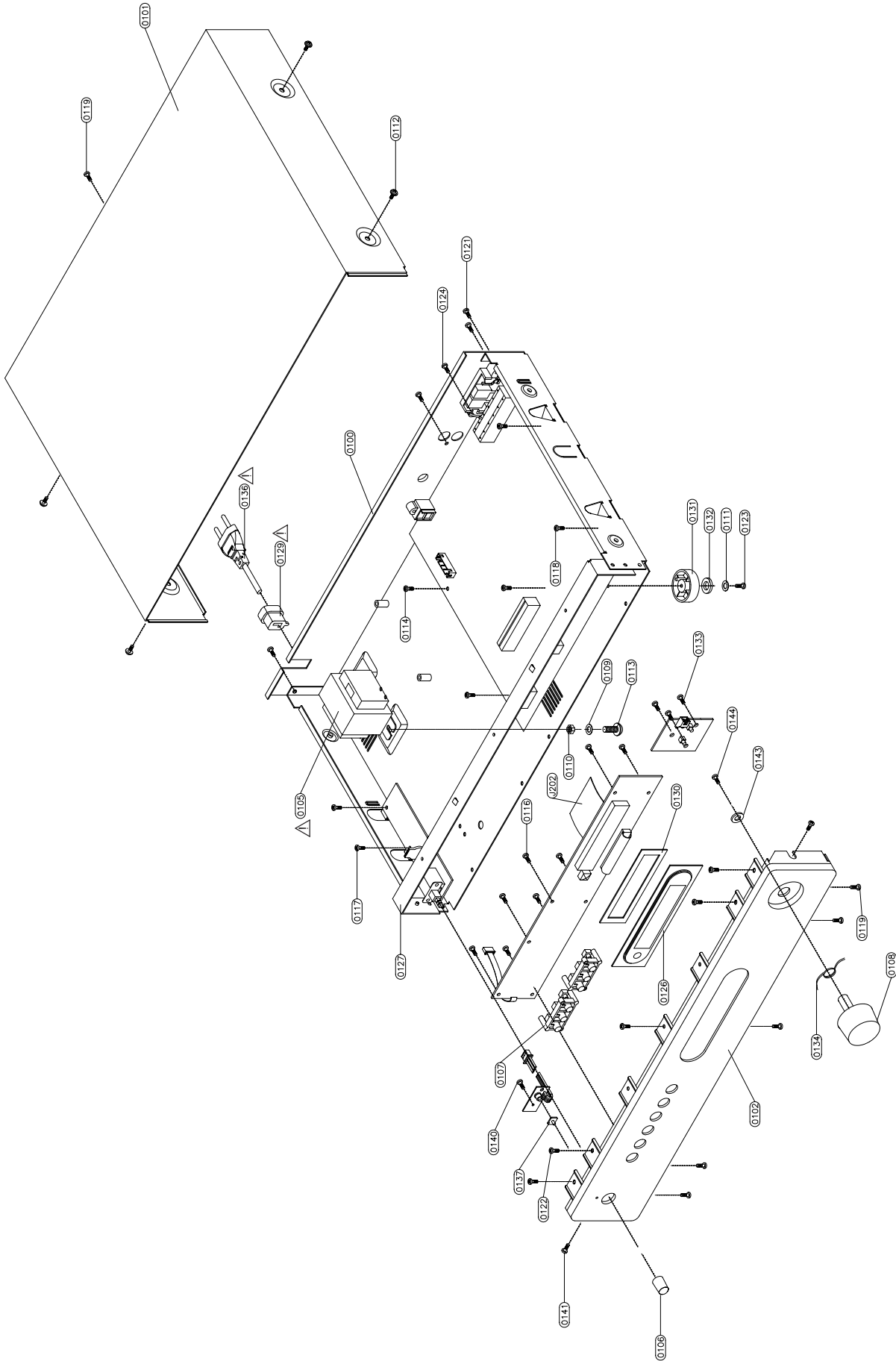
EXPLODED VIEW



EXPLODED VIEW PARTS LIST

ITEM	Part No.	Description
0100 *AH GREY/*AH TI	1402-351A-1	CHASSIA C422 (AH)
0100 *CE GREY/*CE TI	1402-351B-1	CHASSIA C422 (C)
0101 *AH GREY/*CE GREY	1402-3531-0	TOP COVER BLACK (C542)
0101 *AH TI/*CE TI	1402-3532-0	TOP COVER SILVER (C542)
0102 *AH GREY/*CE GREY	1466-5201-1	FASCIA BLACK (C422)
0102 *AH TI/*CE TI	1466-5202-1	FASCIA SILVER (C422)
0105 	1806-3541-0	X'FORMER 120/230V I/P
0106 *AH GREY/*CE GREY	2442-1002-0	POWER BUTTON BLACK
0106 *AH TI/*CE TI	2442-1003-0	POWER BUTTON SILVER
0107 *AH GREY/*CE GREY	2444-1203-0	BUTTON TRIO BLACK
0107 *AH TI/*CE TI	2444-1204-0	BUTTON TR10 TITANIUM
0108 *AH GREY/*CE GREY	2446-6201-1	TUNE/PRESET KNOB BLACK C422
0108 *AH TI/*CE TI	2446-6202-1	TUNE/PRESET KNOB SILVER C422
0109	2600-4008-0973	FLAT WASHER M4X0.8X9.7
0110	2640-4030-0703	M4 NUT (BLK)
0111	2842-3367-0	METAL WASHER
0112 *AH TI/*CE TI	2900-4006-2010	SCM PW M4X6 RECESS WHITE
0112 *AH GREY/*CE GREY	2900-4006-3010	M4X0.5PX6MM W/FLAT
0113	2900-4010-3030	PH W/WASHER M4X10 BL ZN
0114	2904-3006-0000	SCREW M3X6
0116	2954-3008-0000	TAPPING 3X8MM B-TITE
0117	2954-3006-0000	3X6MM B-TITE (YEL.ZN)
0118	2954-3008-0000	TAPPING 3X8MM B-TITE
0119	2954-3008-3000	T3X8MM SELF TAPPING
0120 *AH GREY/*CE GREY	2954-3008-3000	T3X8MM SELF TAPPING
0120 *AH TI/*CE TI	2954-3010-4000	ST SCREW 3X10 BH
0121	2954-3008-3000	T3X8MM SELF TAPPING
0122	2954-3008-0000	TAPPING 3X8MM B-TITE
0123	2954-3008-3000	T3X8MM SELF TAPPING
0124	2954-3008-3000	T3X8MM SELF TAPPING
0125	2600-4008-0973	FLAT WASHER M4X0.8X9.7
0126	3716-4314-0	WINDOW LENS C420 W/SS
0127	1402-3783-2	STRAP (C542)
0128	4151-9411-0	CUSHION 130X10X1MM
0129 	4152-3851-0	SQ. STRAIN RELIEF
0131	4157-0501-1	RUBBER FOOT
0132	4152-4641-1	CUSHION FOOT W/RUBBER WA
0133	2954-3008-0000	TAPPING 3X8MM B-TITE
0134	4134-9281-1	TUNE/PRESET KNOB SPRING

ITEM	Part No.	Description
0136 △ *AH GREY/*AH TI	7009-3100-2	AC CORD 18AWGX2
0136 △ *CE GREY/*CE TI	7009-3110-0	AC CORD (SEMKO)
0137	3714-5706-0	LED LENS (412) CLEAR SAN
0140	2954-3008-0000	TAPPING 3X8MM B-TITE
0141	2954-3008-0000	TAPPING 3X8MM B-TITE
0143	2600-3005-0803	METAL WASHER M3X0.5X8MM
0144	2954-3008-0000	TAPPING 3X8MM B-TITE
0146	2954-2006-0000	TAPPING SCREW 2X6
J202C	7012-5260-0	FLEXIBLE CABLE 35P L=150

- NOTE:**
- The components identified by △ mark are critical for risk of fire and electrical shock.
Replace only with part number specified.
 - <*AH > : USA, Canadian model only.
 - <*C > : European model only.

PACKING DIAGRAM

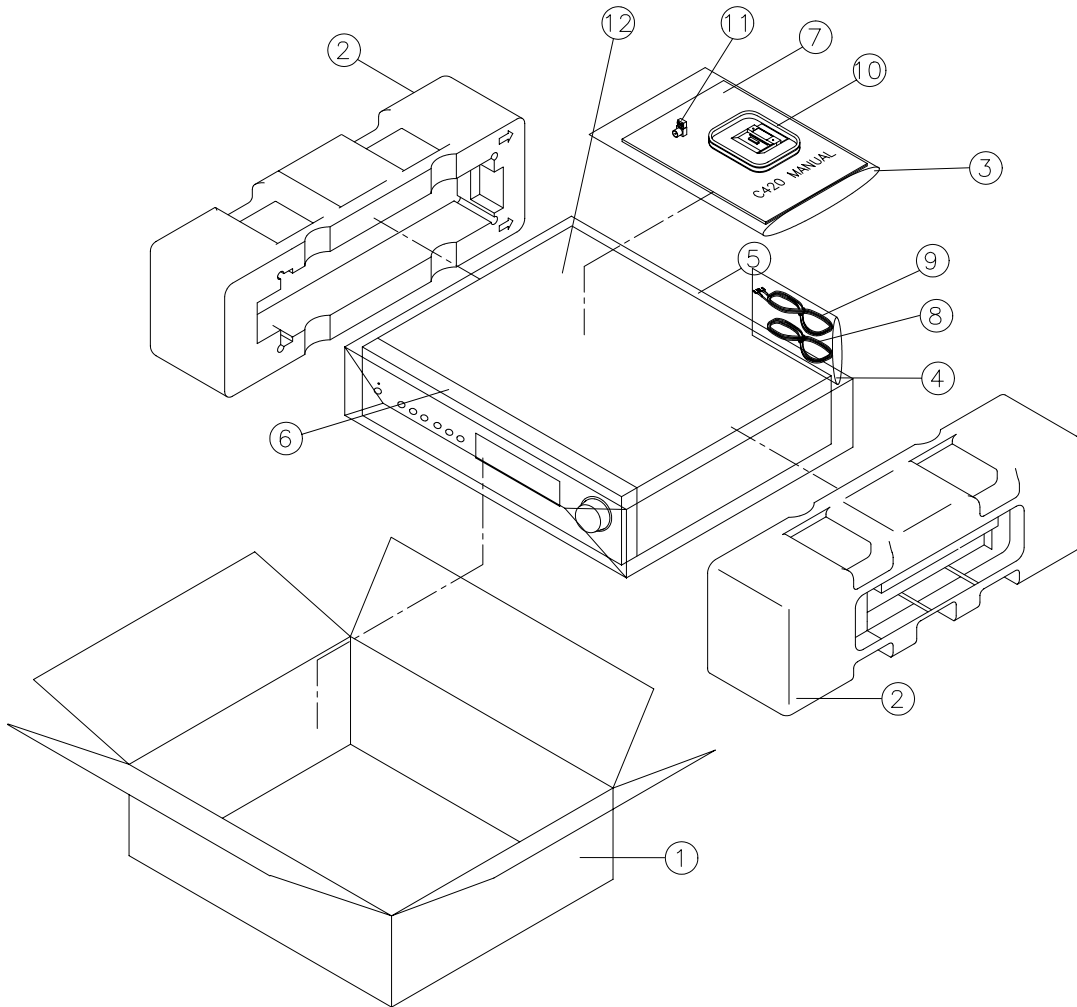

ITEM	PART NO.	DESCRIPTION	Q'TY
1	1408-0203-0	CARTON BOX C422	1
2	1490-3783-2	POLYFORM ENDCAP	2
3	1497-1062-0	POLYBAG MANUAL	1
4	1497-1302-0	POLYBAG	1
5	1497-1332-1	POLYBAG	1
6	1497-1432-0	EPE BAG (412)	1
7	4301-7074-1	INSTRUCTION MANUAL	1
8	2103-7302-1	RCA PLUG (MALE)	1
9	2107-0661-1	300-OHM T ANTENNA	1
10	2113-1155-0	AM LOOP ANTENNA	1
11	2103-6101-0	RF CONNECTION PLUG (F-TYPE)	1
12	1450-2520-0	WHITE PAPER	1

Proprietary information for servicing purposes only. The information herein may not be used commercially without the prior written agreement of NAD Electronics International, Toronto, Canada.

SERVICE MANUAL

C 422

STEREO
AM/FM TUNER

© NAD 2004

NAD ELECTRONICS INTERNATIONAL
TORONTO