

SERVICE MANUAL

C 425

**STEREO
AM/FM TUNER**

C 425

**STEREO
AM/FM TUNER**

NAD

SERVICE SAFETY PRECAUTIONS

1. Safety check out

(Only U.S.A. model)

Before returning the product to the customer, make leakage current or resistance measurements to determine that exposed parts are acceptably insulated from the supply circuit.

Parts marked with the symbol \triangle are critical with regard to the risk of fire and electric shock. Replace only with parts recommended by the manufacturer.

CONTENTS

DESCRIPTION	PAGE
SPECIFICATIONS	3
REAR PANEL / FRONT PANEL	4
DISASSEMBLY INSTRUCTIONS	5
BLOCK DIAGRAM	6
WIRING DIAGRAM	7
ADJUSTMENT POINTS DIAGRAM	8
INSTRUMENT SETUP	9
ALIGNMENT PROCEDURES	10
PCB LAYOUT	11-12
SCHEMATIC DIAGRAM	13-14
IC BLOCK DIAGRAM	15-18
ELECTRICAL PARTS LIST	19-27
EXPLODED VIEW	28
EXPLODED VIEW PARTS LIST	29-30
PACKING DIAGRAM	31

SPECIFICATIONS

AM TUNER SECTION

Input level is expressed as the reading in open-circuit of 75-ohm source impedance signal generator

Usable Sensitivity (999/1000kHz)		$\leq 30\text{dB}\mu$
S/N Ratio (5mV in)		$\geq 38\text{dB}$
THD (5mV in)		$\leq 3\%$
IF Rejection (450kHz)		$\geq 36\text{dB}$
Image Rejection (F+2xIF)		$\geq 28\text{dB}$
Selectivity		$\geq 17\text{dB}$
Output		130 +/-20mV
Loop Sensitivity (20dB S/N)		
	999/1000 kHz	$\leq 66\text{ dB}$
	603/600 kHz	$\leq 66\text{ dB}$
	1404/1400 kHz	$\leq 66\text{ dB}$
Frequency response (100 - 2.3 kHz, 5mV)		$\pm 6\text{ dB}$

FM TUNER SECTION

Input level is expressed as the reading in open-circuit of 75-ohm source impedance signal generator

		<u>*C</u>	<u>*AH</u>
Usable Sensitivity (98 MHz)		$\leq 13\text{ dB}\mu$	$\leq 13\text{ dB}\mu$
Signal / Noise Ratio	Mono	$\geq 72\text{ dB}$	$\geq 72\text{ dB}$
(60 dB μ , IHF wtd)	Stereo	$\geq 66\text{ dB}$	$\geq 66\text{ dB}$
Frequency Response (20 Hz - 15 kHz, 60 dB μ)		$0\pm 1.0\text{ dB}$	$0\pm 1.0\text{ dB}$
Channel Separation (60 dB μ)	30 Hz	$\geq 33\text{ dB}$	$\geq 33\text{ dB}$
	1 kHz	$\geq 42\text{ dB}$	$\geq 42\text{ dB}$
	10 kHz	$\geq 32\text{ dB}$	$\geq 32\text{ dB}$
Alternate Channel Sensitivity			
(40 dB μ , $\pm 400\text{ kHz}$)		$\geq 60\text{ dB}$	$\geq 45\text{ dB}$
Capture Ratio (40 dB μ)		$\leq 3\text{ dB}$	$\leq 3\text{ dB}$
AM Suppression			
(60 dB μ , 100% Mod.FM, 30% Mod AM)		$\geq 65\text{ dB}$	$\geq 65\text{ dB}$
Image Rejection (119.4 MHz)		$\geq 85\text{ dB}$	$\geq 85\text{ dB}$
I.F. Rejection (10.7 MHz)		$\geq 78\text{ dB}$	$\geq 78\text{ dB}$
Pilot Suppression (60 dB μ)		$\geq 60\text{ dB}$	$\geq 60\text{ dB}$
THD (60 dB μ , L=R 75 kHz for AH, 40 kHz Dev for C)			
	Mono	$\leq 0.25\%$	$\leq 0.25\%$
	Stereo	$\leq 0.35\%$	$\leq 0.35\%$
Auto-Search sensitivity	On	$\geq 24\text{ dB}\mu$	$\geq 24\text{ dB}\mu$
	Off	$\leq 15\text{ dB}\mu$	$\leq 15\text{ dB}\mu$
RDS Decode Sensitivity		$\leq 26\text{ dB}\mu$	$\leq 26\text{ dB}\mu$

PHYSICAL SPECIFICATIONS

Dimensions (Width x Height x Depth)	435 x 80 x 285 mm
Net weight	4 kg (8.8 lbs)
Shipping weight	5.1 kg (11.22 lbs)

REAR PANEL / FRONT PANEL

REAR PANEL

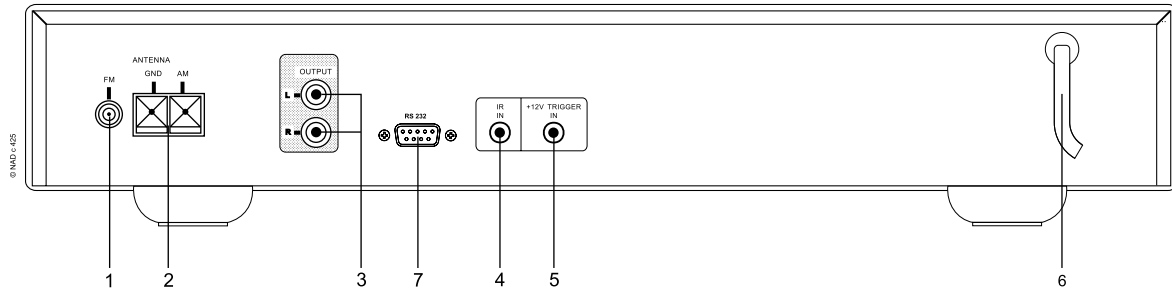

- | | |
|---------------|-------------------|
| 1. FM ANTENNA | 5. 12V TRIGGER IN |
| 2. AM ANTENNA | 6. AC LINE CORD |
| 3. OUTPUT | 7. RS-232 |
| 4. IR IN | |

FRONT PANEL

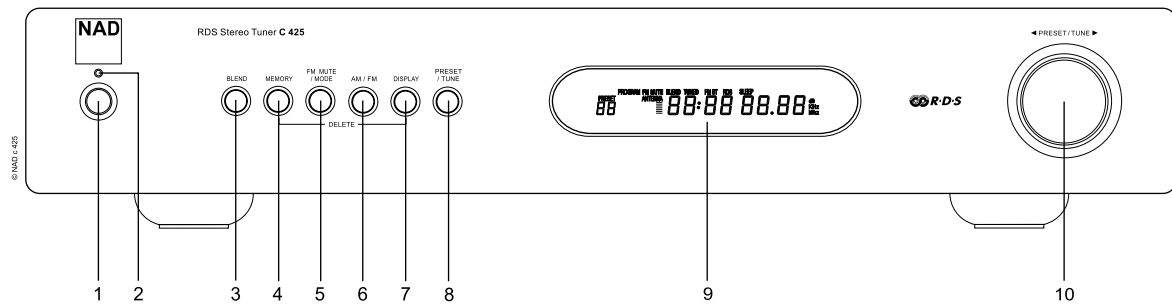

- | | |
|---------------------------|---------------------------|
| 1. POWER ON / OFF | 6. AM / FM |
| 2. POWER STATUS INDICATOR | 7. DISPLAY |
| 3. BLEND | 8. PRESET / TUNE |
| 4. MEMORY | 9. DISPLAY AREA |
| 5. FM MUTE / MODE | 10. PRESET / TUNE CONTROL |

IMPORTANT NOTES

- Show the software version**
Press "BLEND" and "AM/FM".
- Light UP all the icon on the VFD**
Press "BLEND" & "DISPLAY".
- Factory test resets**
When VFD all Light press any key.
- AM Step 10K/9K Change**
When AM band, press "AM/FM" & "PRESET/TUNE".
- Shipment resets**
When pressing "DISPLAY" & "PRESET/TUNE" to VFD all Light, press any key.

DISASSEMBLY INSTRUCTIONS

1. Remove machine screws M 4.0 x 6.0 (① to ④) from the side panels.
Remove tapping screw 3.0 x 8.5 (⑤) from the back panel.
Refer to **Figure No.1**.

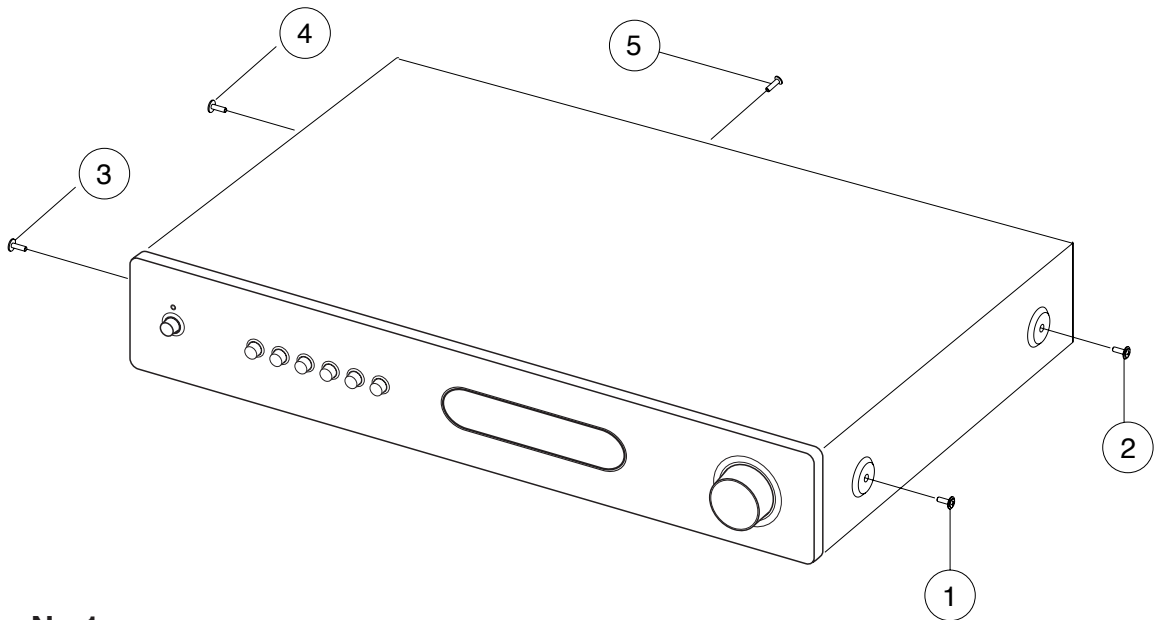

Figure No.1

2. Pull both sides of the TOP COVER slightly outwards (⑥) and tilt approx. 35° and then remove in the direction as indicated by the arrow (⑦). Refer to **Figure No.2**.

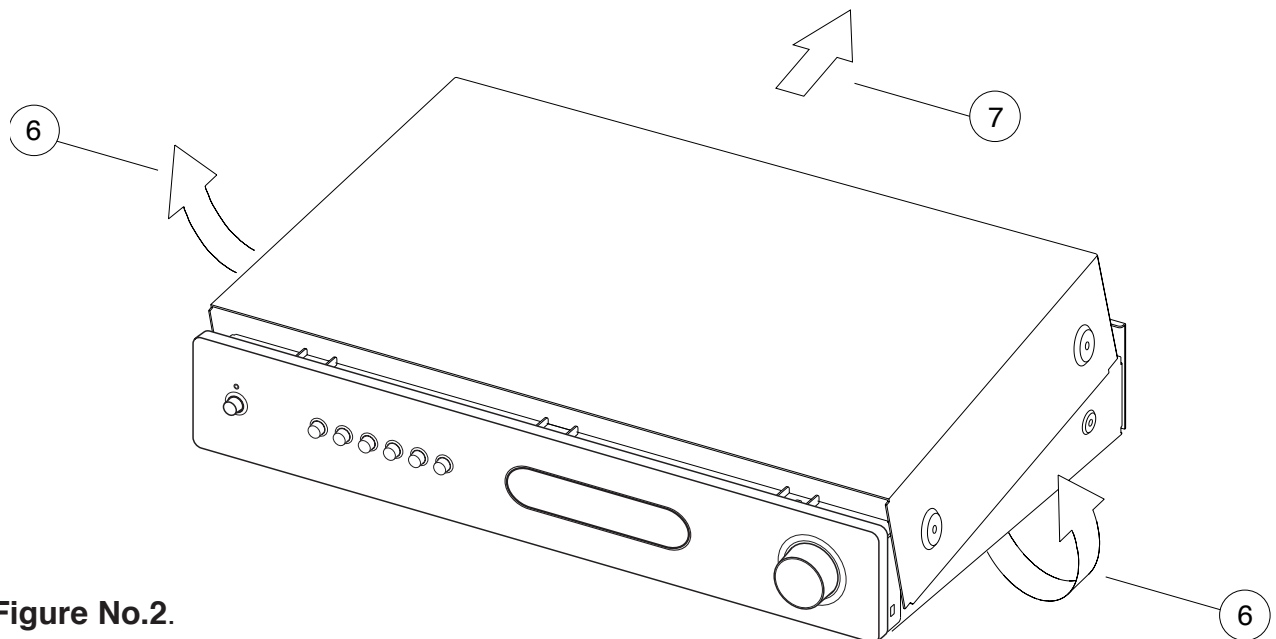
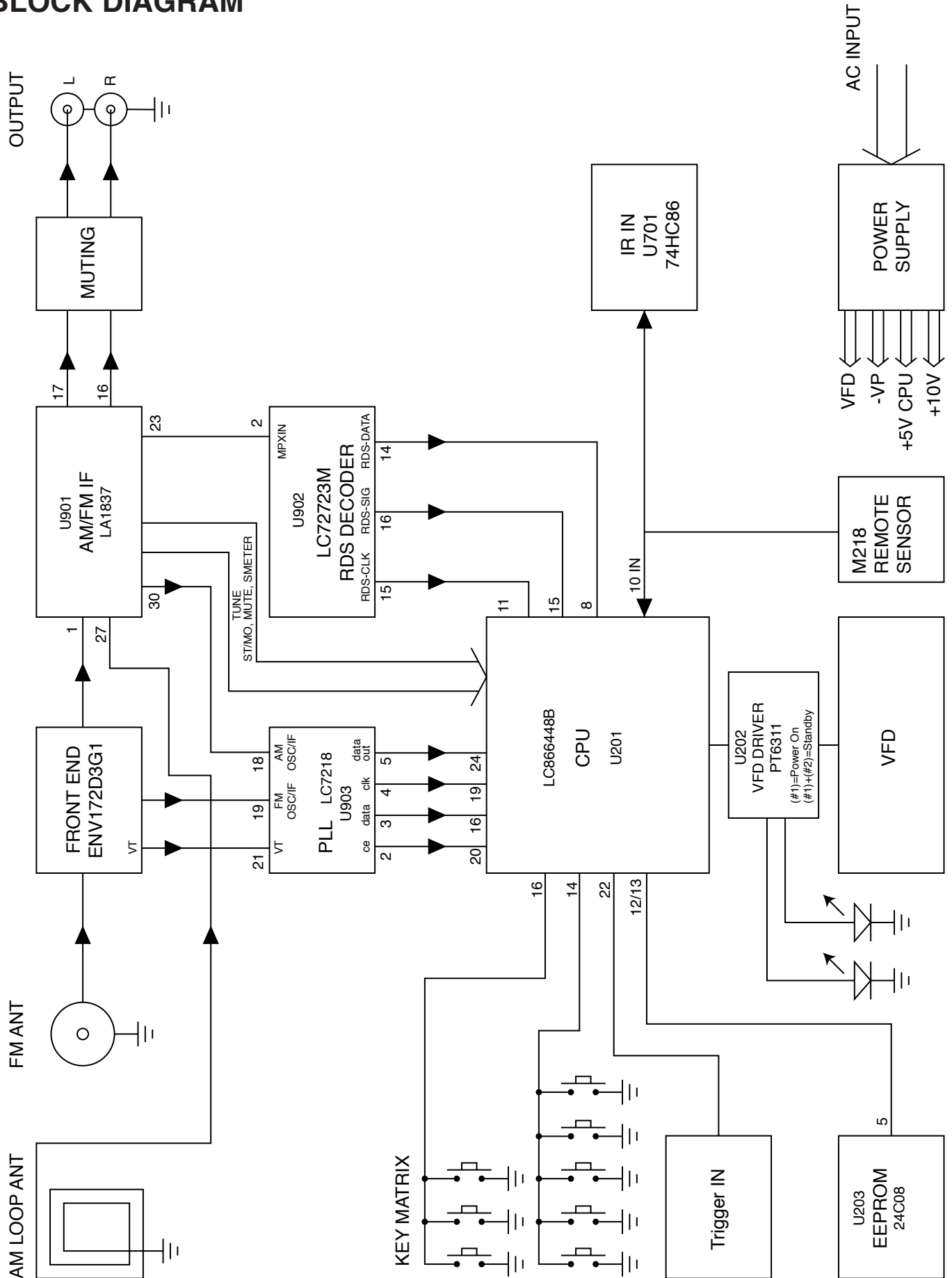
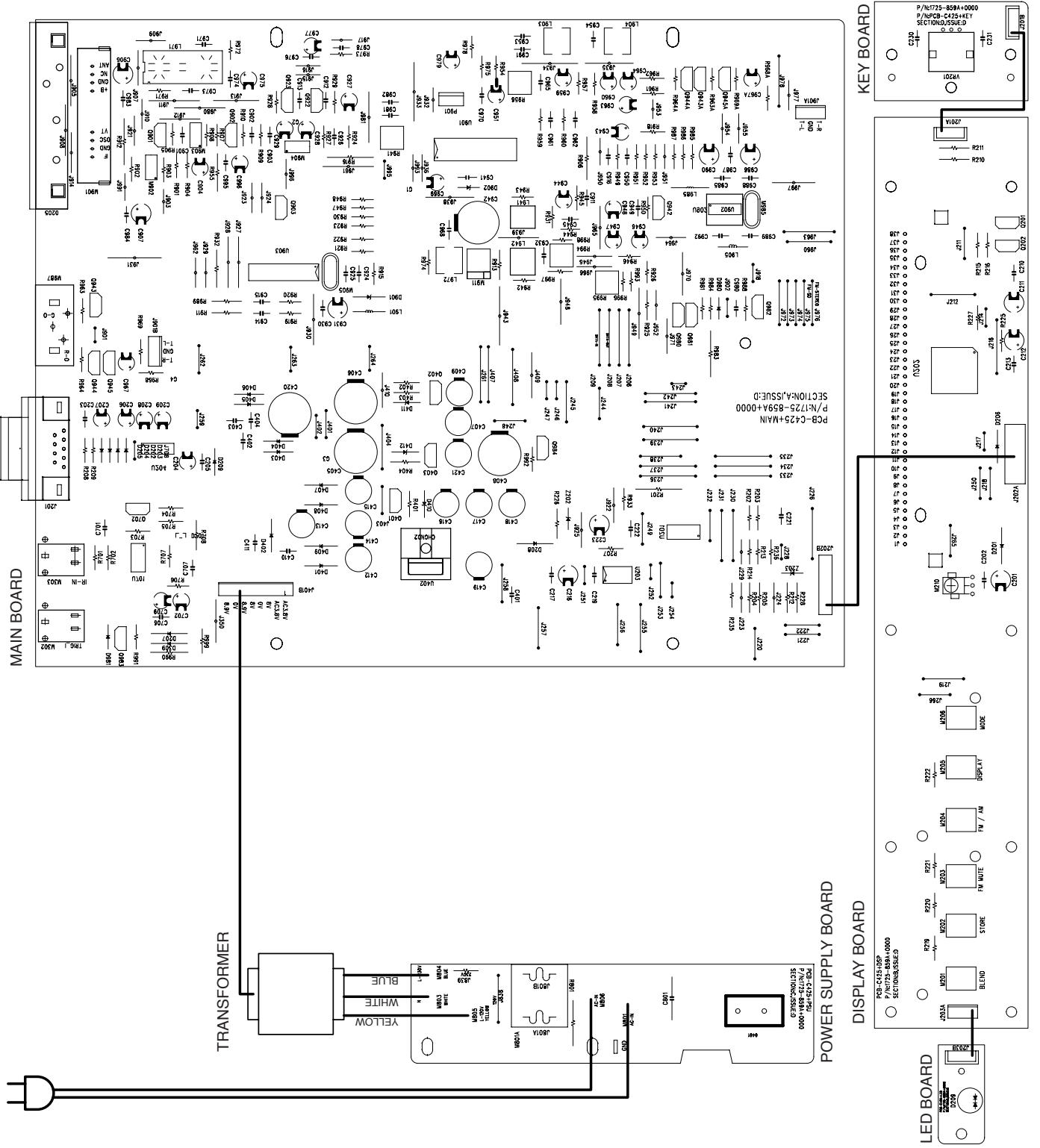

Figure No.2.

BLOCK DIAGRAM



WIRING DIAGRAM



INSTRUMENT SETUP

1. FM MEASUREMENT

Fig. 1

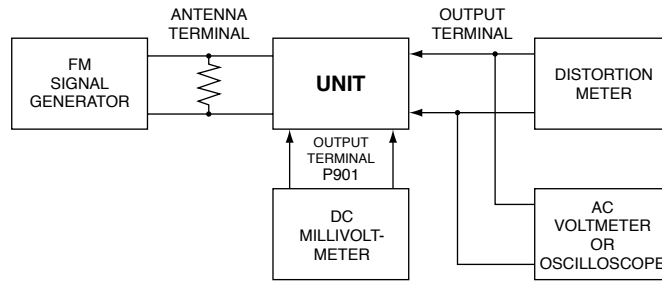
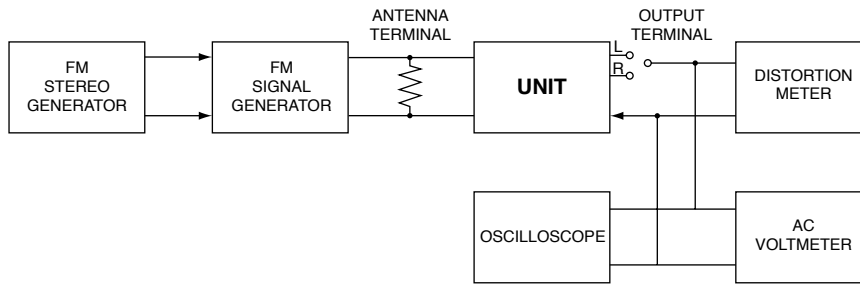
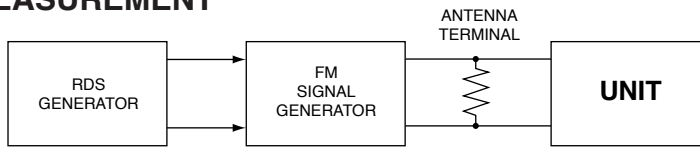

Fig. 2



2. RDS MEASUREMENT

Fig. 3



3. AM MEASUREMENT

Fig. 4

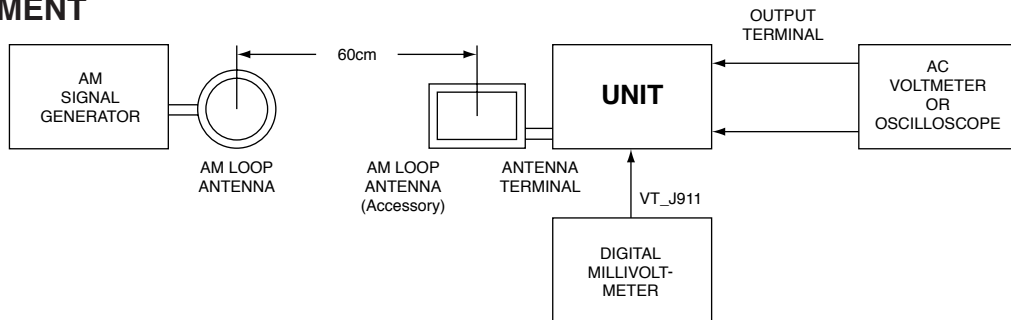

ALIGNMENT PROCEDURES

FM/RDS SECTION

- FM mono: 1kHz, 75kHz devi., 60dB/μV
- FM stereo: 1kHz, 67.5kHz devi., 60dB/μV
Pilot signal 19kHz 7.5kHz devi.

OUTPUTS

- Connect the 47Kohm resistor unless otherwise noted.

Item	Step	Connection of instrument	FM SG output	Stereo modulator output	Tuning frequency	Output indicator	Adjustment point	Adjust for	Remarks
FM IF/RF	1	Fig.1	99.0MHz 1kHz 75kHz devi. 65dBf (60dB)	-	99.0MHz	DC voltmeter	L941	0±70mV	FM MUTE/MODE switch: ON/AUTO Repeat the steps 1 to 3 until no further adjustment is necessary.
	AC voltmeter					IFT on the front end	Maximum		
	Distortion analyzer					L942	Minimum		
Stereo Distortion		Fig.2	99.0MHz Ext. mod. 65dBf (60dB)	Channel L or R 1kHz	99.0MHz	Distortion analyzer	IFT on the front end	Minimum	FM MUTE/MODE switch: ON/AUTO Don't turn more than ±180°
Stereo Separation		Fig.2	99.0MHz Ext. mod. 65dBf (60dB)	Channel L or R 1kHz	99.0MHz	Oscilloscope	R941	Maximum separation	Repeat stereo distortion and stereo separation alignment until THD at minimum and separation at maximum.
						Distortion Meter		Minimum	
Mute Level		Fig.1	99.0MHz 18dB	-	99.0MHz	Oscilloscope	R956	Signal output	
RDS		Fig.3	99.0MHz Ext. mod. 65dBf (60dB) RDS 2% MOD	-	99.0MHz	-	-	-	Decode the RDS- Program station

AM SECTION

AF Modulation: 400Hz, 30%

For AH Version

Step	AM SG output	Tuning frequency	Output indicator	Adjustment point	Adjust for
1	-	530kHz	Digital DC voltmeter	OSC coil on RF block M971	1.35±0.2V
2	600kHz 400Hz 30% mod. 60dB/m	600kHz	AC voltmeter	RF coil on RF block M971	Maximum
3	600kHz 400Hz 30% mod. 60dB/m	990kHz	AC voltmeter	L972	Maximum

For C Version

Step	AM SG output	Tuning frequency	Output indicator	Adjustment point	Adjust for
1	-	522kHz or 531kHz	Digital DC voltmeter	OSC coil on RF block M971	1.3±0.2V (522kHz) 1.35±0.2V (531kHz)
2	600kHz 400Hz 30% mod. 60dB/m	603kHz	AC voltmeter	RF coil on RF block M971	Maximum
3	600kHz 400Hz 30% mod. 60dB/m	999kHz	AC voltmeter	L972	Maximum

PCB LAYOUT

POWER SUPPLY BOARD

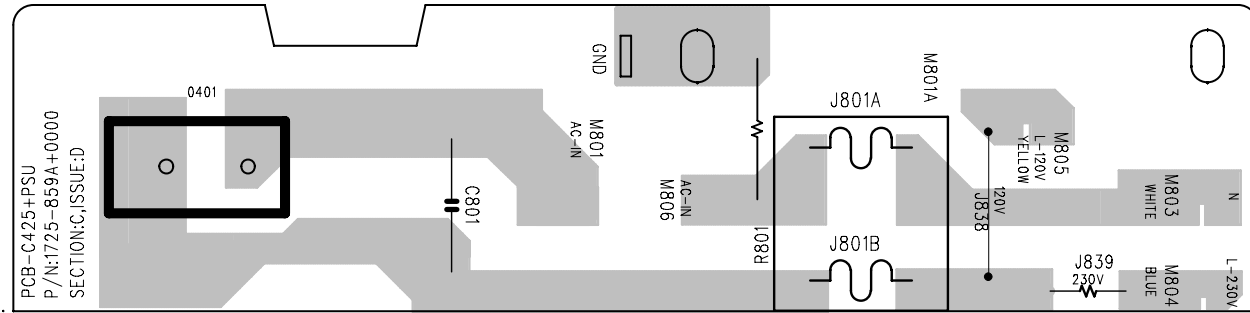

LED BOARD

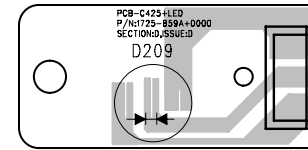

KEY BOARD

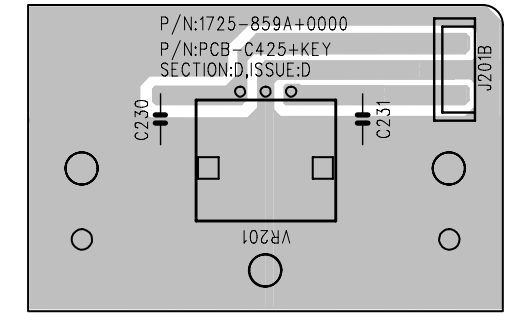

DISPLAY BOARD

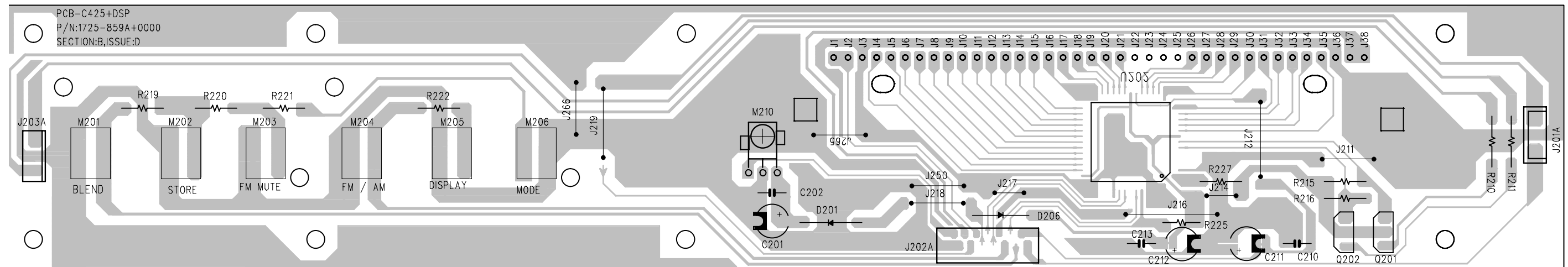

SCHEMATIC DIAGRAM

KEY / MCU / DISPLAY

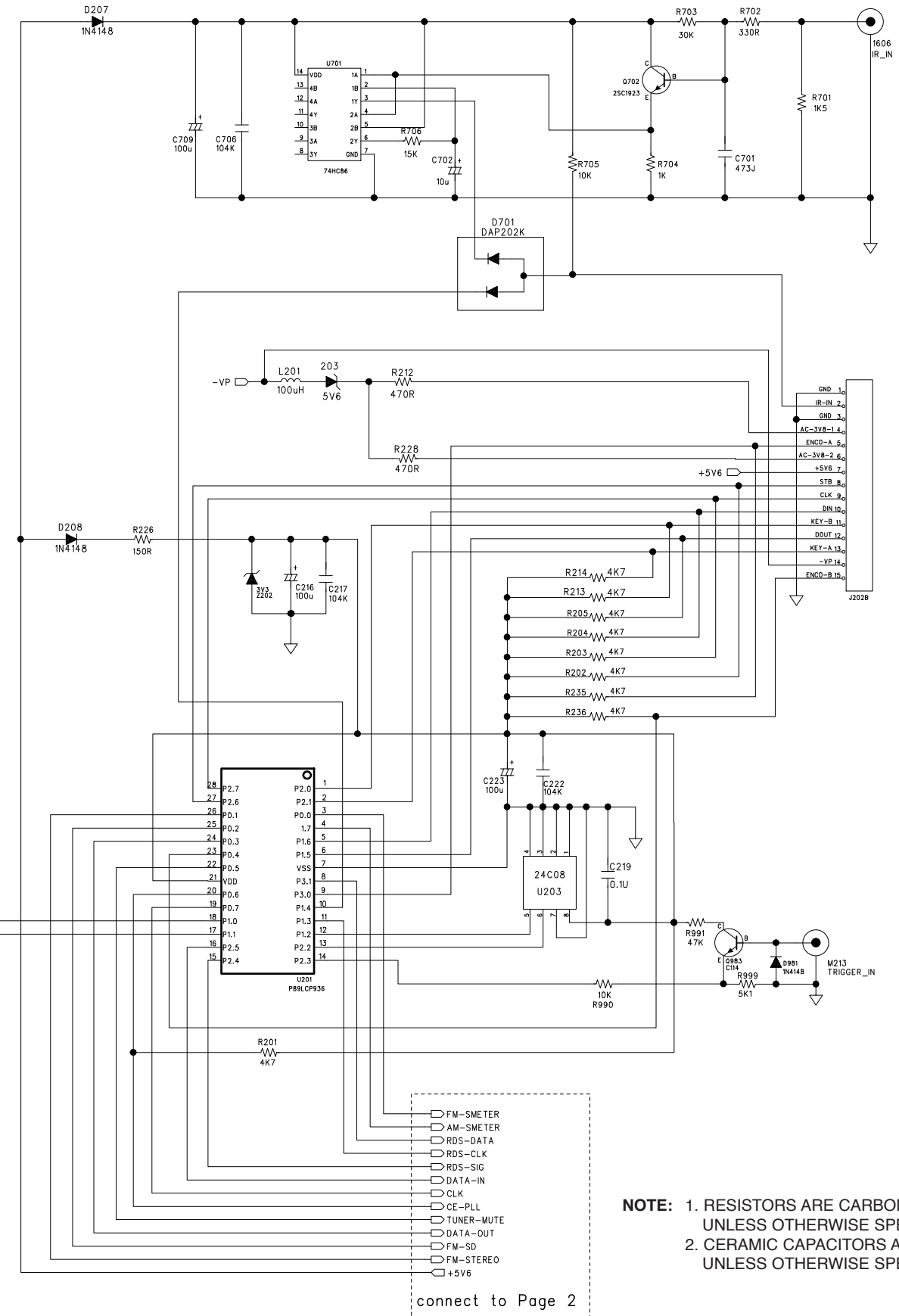
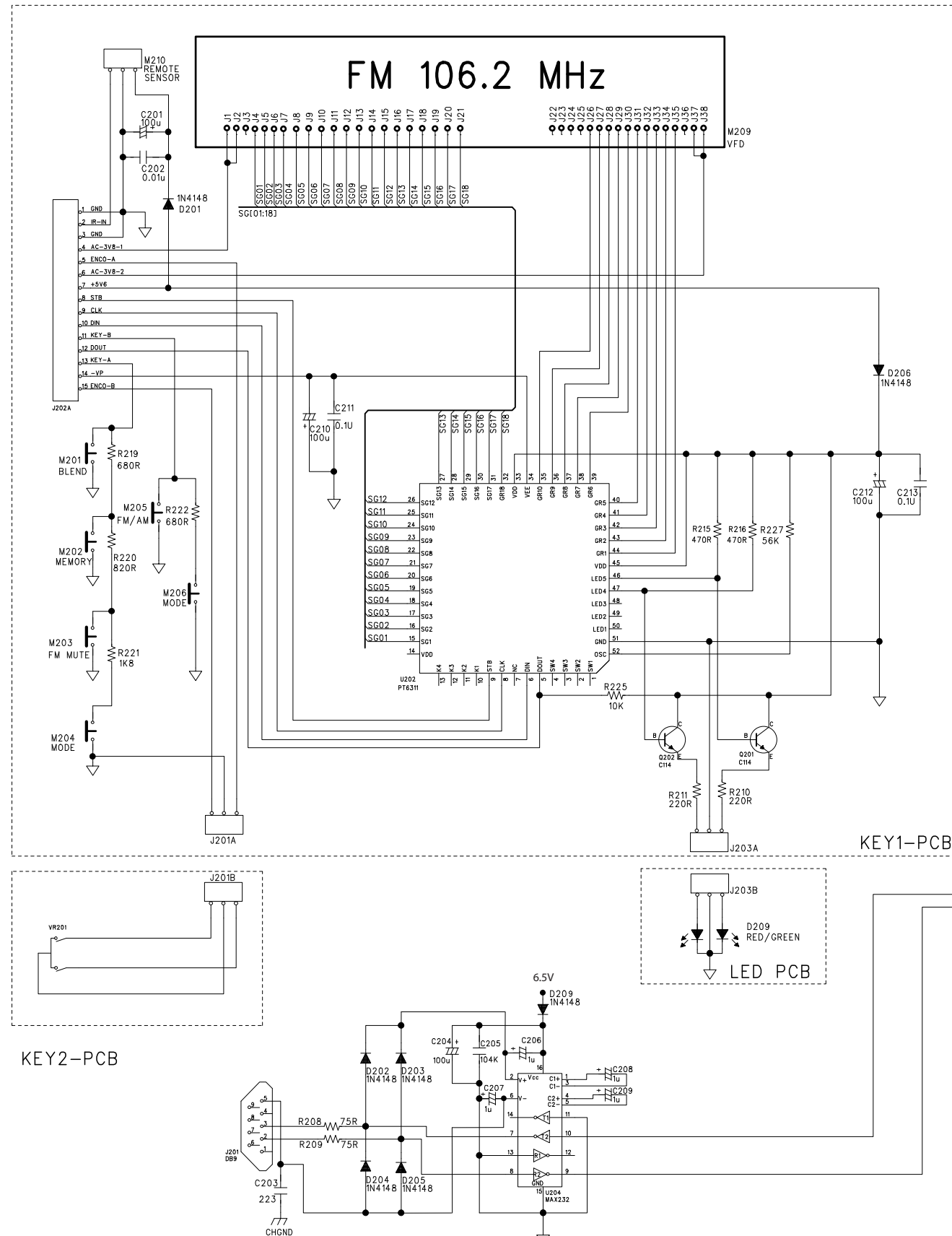

TUNER

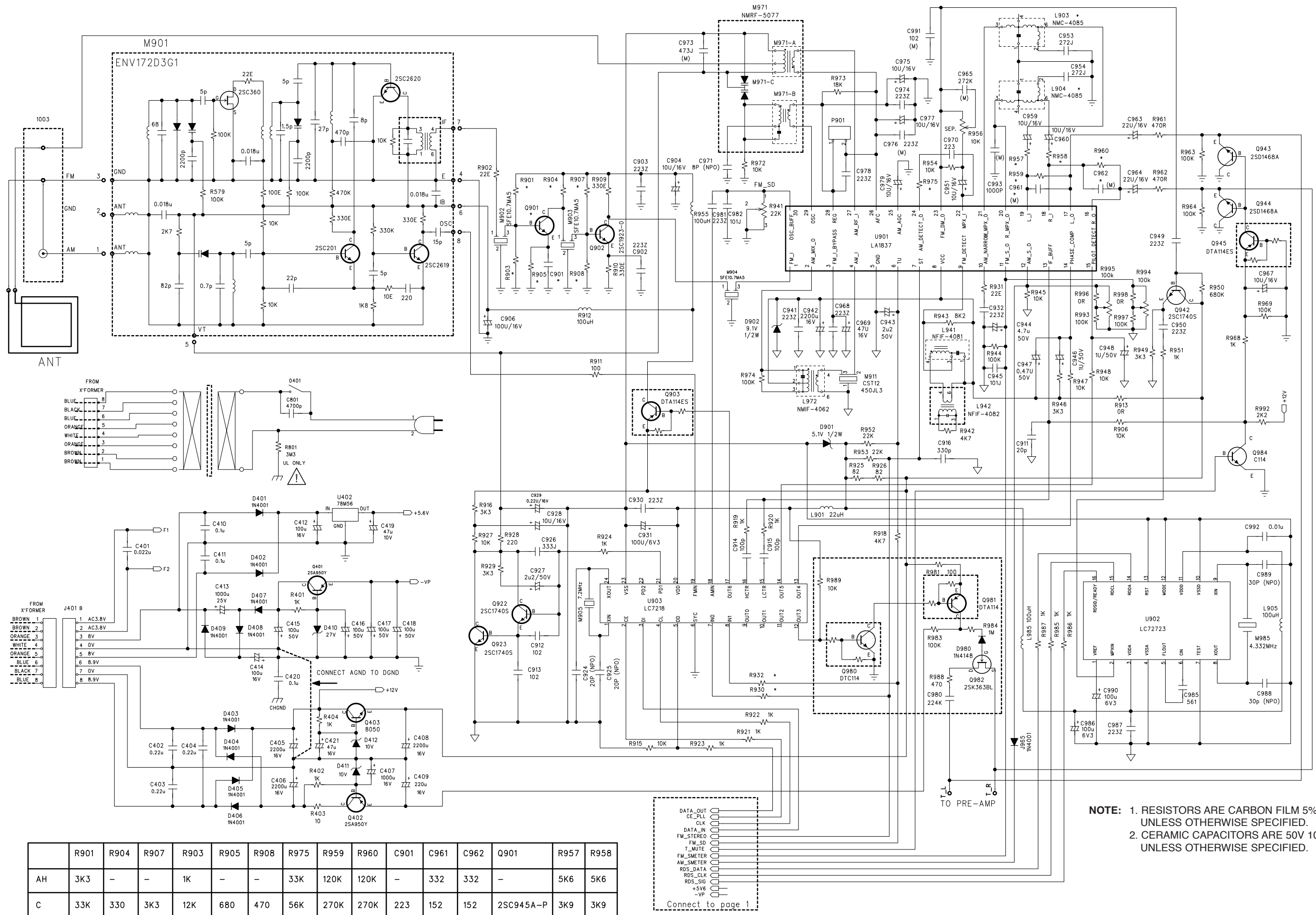

	R901	R904	R907	R903	R905	R908	R975	R959	R960	C901	C961	C962	Q901	R957	R958
AH	3K3	-	-	1K	-	-	33K	120K	120K	-	332	332	-	5K6	5K6
C	33K	330	3K3	12K	680	470	56K	270K	270K	223	152	152	2SC945A-P	3K9	3K9

IC BLOCK DIAGRAM

Display Board
U202: PT6311

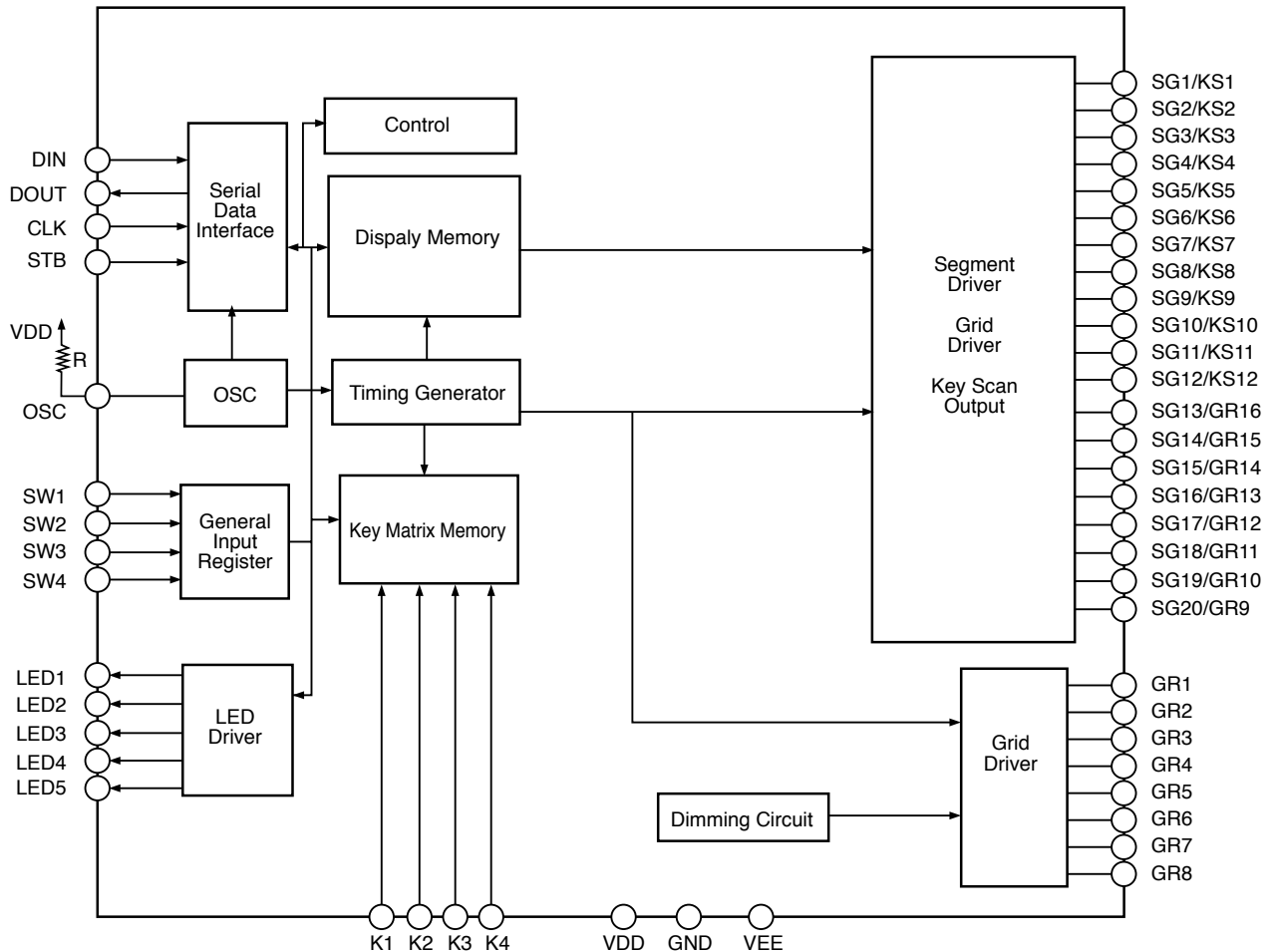
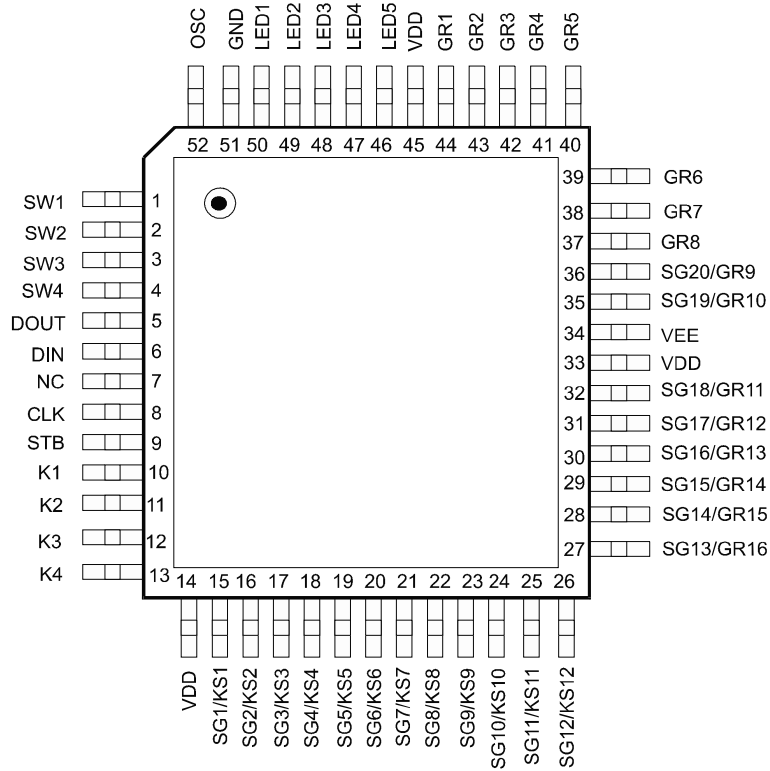

Main Board

U201: P89LCP936

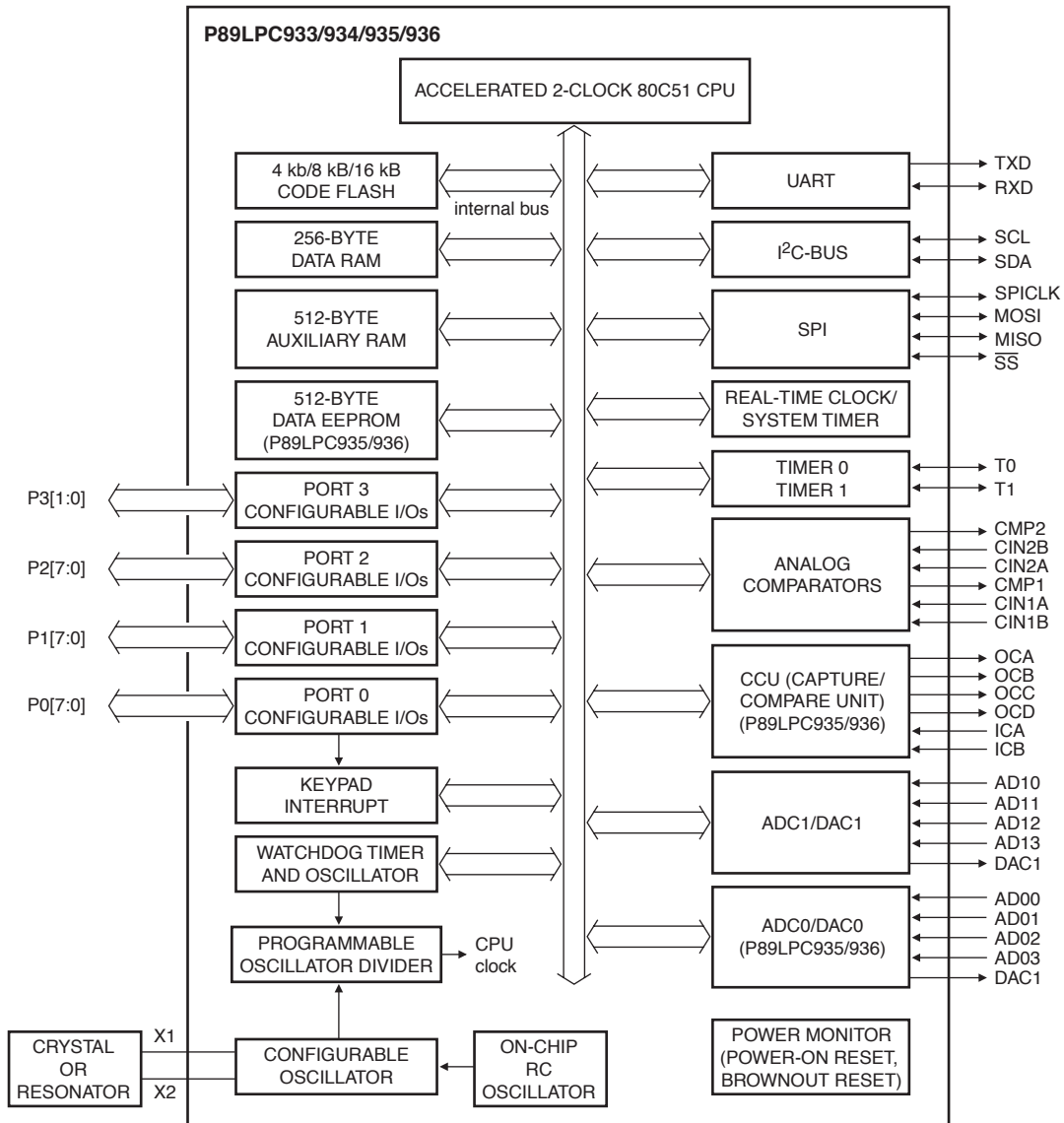
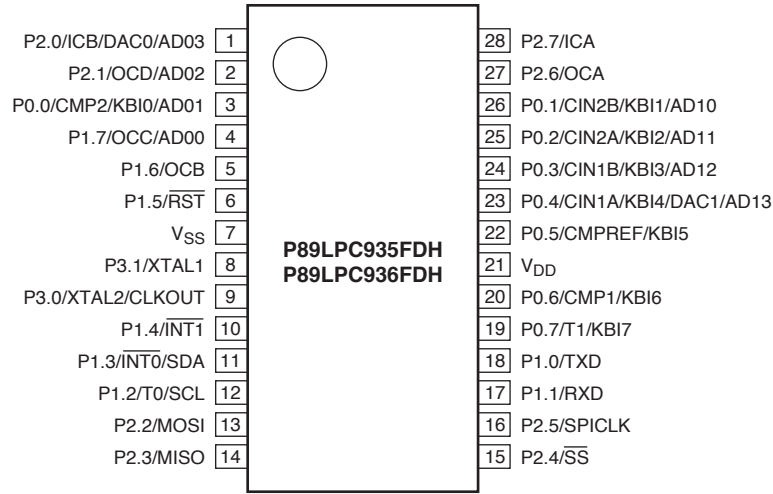

Main Board

U203: AT24C08A-10PU

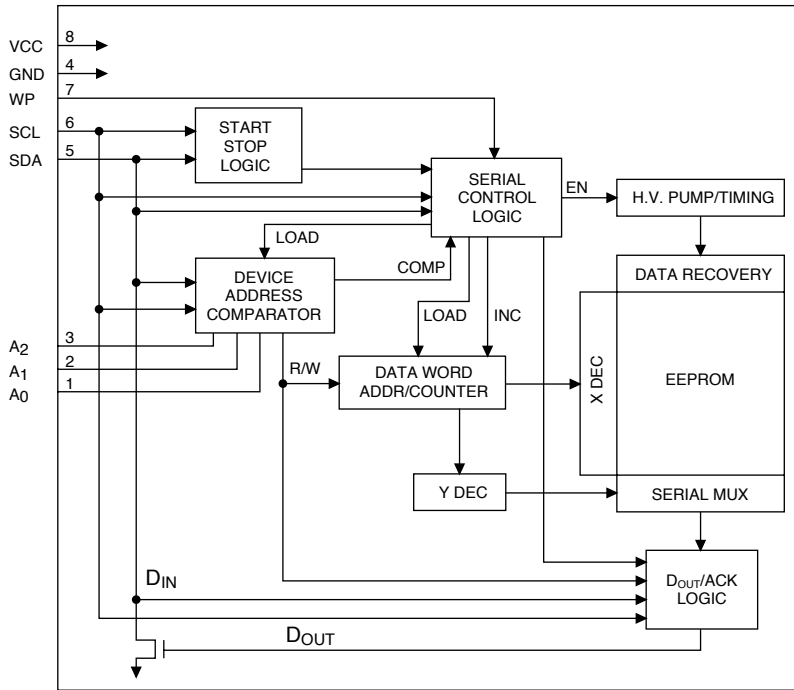

Main Board

U204: MAX232D

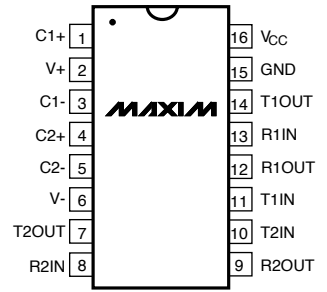

Main Board

U402: NJM78M56FA

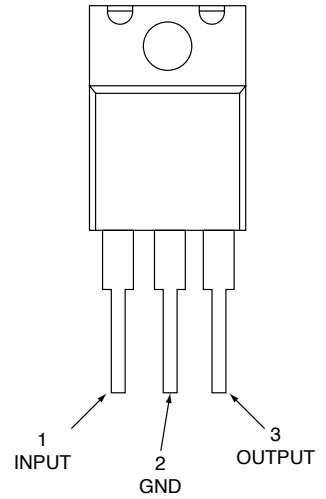

Main Board

U701: 74HC86

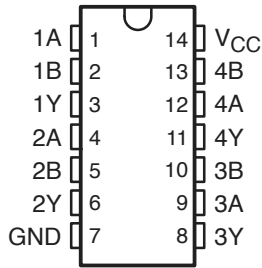

Main Board

U901: LA1837L-E

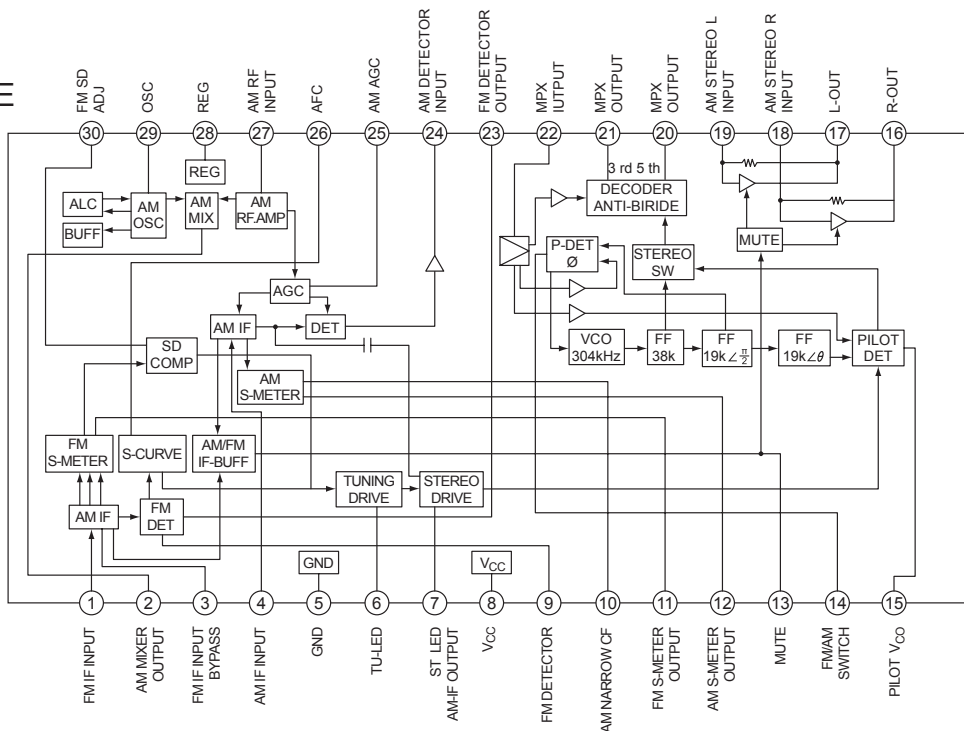

Main Board

U902: LC72723M

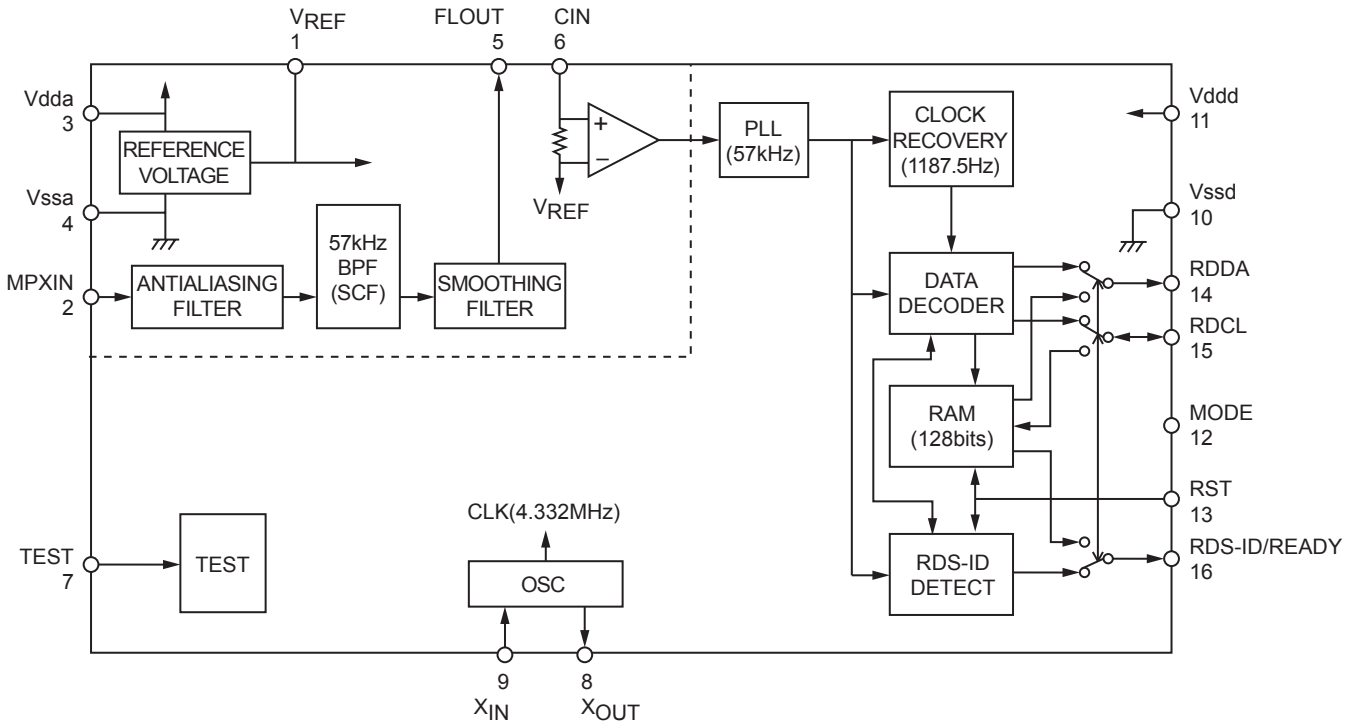

Main Board

U903: LC7218-E

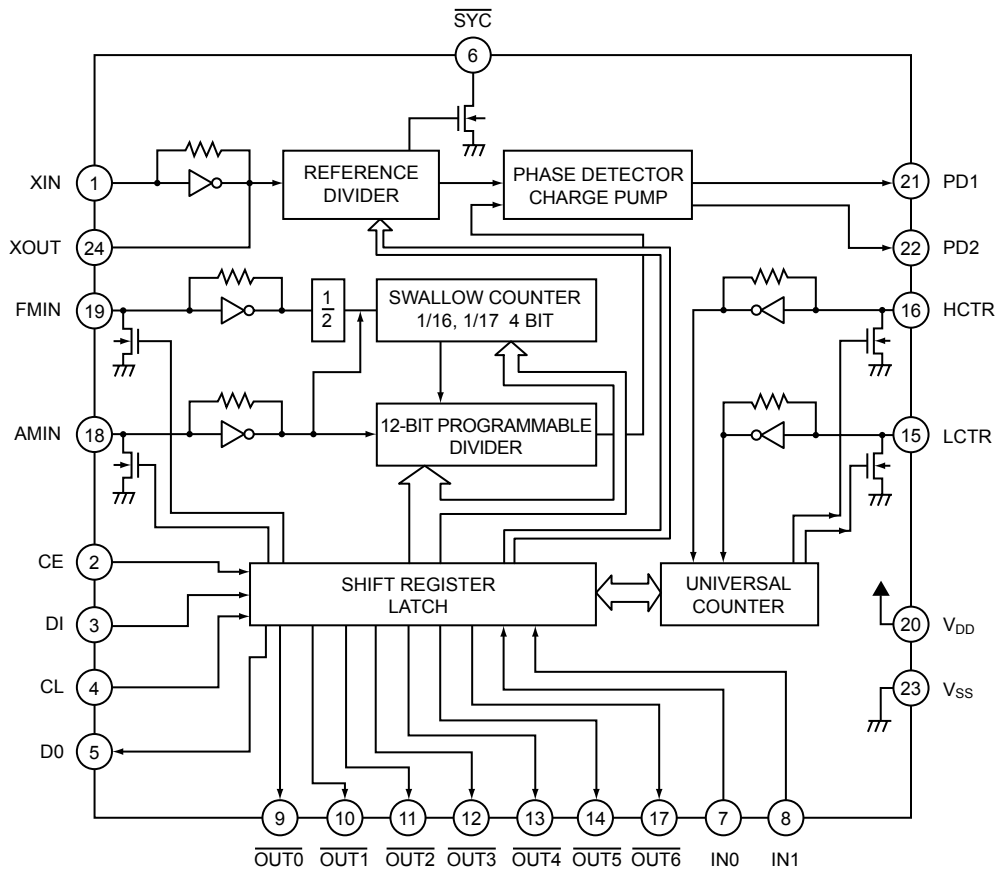

ELECTRICAL PARTS LIST

Location	Part Number	Description
DISPLAY ASSY		
PC BOARD		
	PCB-C42526+DSP	PCB ASSY DISPLAY
PCB		
	1725-859A+0000	PCB MAIN/KEY/DIS/PSU/LED
CAPACITOR		
C201	157B-107M+K-LII	CE 6.3V 100UF 20% RLT
C202	150F-103K+2-FC	CC 50V 0.01uF 10% AT 3.5
C210	150F-104K+2-FC	CC 50V 0.1UF 10% AT
C211	157Q-107M+K-LUI	CE 35V 100UF 20% RLT
C212	157B-107M+K-LII	CE 6.3V 100UF 20% RLT
C213	150F-104K+2-FC	CC 50V 0.1UF 10% AT
DIODE		
D201, D206	4804-1480+C	DIODE 1N4148M-A(WA) ATS
WAFER/CONNECTOR		
J202A	2101-1441+0	FLEXIBLE CONN 15P P1.0 R
J203A	2102-031R+004	WAFER 3P P2.5 RIGHT
TRANSISTOR		
Q201, Q202	485C-114E+K	TR DTC114ES RLT
RESISTOR		
R210, R211	4701-221J+2	RCF 1/8W 220R 5% AT
R215, R216	4701-471J+2	RCF 1/8W 470R 5% AT
R219	4701-681J+2	RCF 1/8W 680R 5% AT
R220	4701-821J+2	RCF 1/8W 820R 5% AT
R221	4701-182J+2	RCF 1/8W 1.8K 5% AT
R222	4701-681J+2	RCF 1/8W 680R 5% AT
R227	4701-563J+2	RCF 1/8W 56K 5% AT
IC		
U202	3131-8700+0	IC PT6311(L) VFD DRIVER
SWITCH		
M201, M202, M203, M204, M205, M206	5200-3538+0	SWITCH, TACT SKHHBY 7MM

Location	Part Number	Description
WIRE		
J201A	7012-6688+0	CONN WIRE 3P P=2.5 26AWG
MISCELLANEOUS		
M209	4154-2101+0	VFD HOLDER
M210	4814-3TE2+3	IR SENSOR PIC-26043TE2
VFD	2460-1961+0	DISPLAY-VFD HNA-10SM55
KEY ASSY		
PC BOARD		
	PCB-C42526+KEY	PCB ASSY KEY C425
PCB		
	1725-859A+0000	PCB MAIN/KEY/DIS/PSU/LED
CAPACITOR		
C230, C231	150F-103K+2-FC	CC 50V 0.01uF 10% AT 3.5
WAFER		
J201B	2102-031R+004	WAFER 3P P2.5 RIGHT
MISCELLANEOUS		
VR201	5200-4951+0	ENCODER ROTARY DPDT
LED ASSY		
PC BOARD		
	PCB-C42526+LED	PCB ASSY LED
PCB		
	1725-859A+0000	PCB MAIN/KEY/DIS/PSU/LED
LED		
D209	3700-3517+RG	LED RED/GREEN (L-469HGW)
WIRE		
J203B	7012-6688+0	CONN WIRE 3P P=2.5 26AWG
MAIN ASSY		
PC BOARD		
*EU	PCB-C42526+MAIN	PCB ASSY MAIN

Location	Part Number	Description
*CA	PCB-C425D6+MAIN	PCB ASSY MAIN
PCB		
	1725-859A+0000	PCB MAIN/KEY/DIS/PSU/LED
CAPACITOR		
C203	150F-223K+2-FD	CC 50V 0.022uF 10% AT
C204	157D-107M+K-IUI	CE 16V 100UF 20% RLT
C205	150F-104K+K-II	CC 50V 0.1U 10% RLT 5x5
C206, C207, C208, C209	157F-105M+K-IUI	CE 50V 1UF 20% RLT 5X11
C213 *CA	150F-223K+2-FD	CC 50V 0.022uF 10% AT
C217	150F-223K+2-FD	CC 50V 0.022uF 10% AT
C219, C222	150F-104K+K-II	CC 50V 0.1U 10% RLT 5x5
C223	157F-475M+K-IUI	CE 50V 4.7UF 20% RLT
C401, C402, C403, C404	153F-224J+K-MIB	CM 50V 0.22U 5% RLT 7X5
C405, C406	157D-228M+5-X=I	CE 16V 2200UF 20% RL
C407	157D-226M+K-IUI	CE 16V 22UF 20% RLT 5X11
C408	157D-228M+5-X=I	CE 16V 2200UF 20% RL
C409	157D-227M+K-LUI	CE 16V 220UF 20% RLT
C410, C411	150F-104K+K-II	CC 50V 0.1U 10% RLT 5x5
C412	157D-107M+K-IUI	CE 16V 100UF 20% RLT
C413	157E-227M+K-OVI	CE 25V 220UF 20% RLT
C414	157D-107M+K-IUI	CE 16V 100UF 20% RLT
C415, C416, C417, C418	157F-107M+K-OVI	CE 50V 100U 20% RLT
C419	157B-107M+K-LII	CE 6.3V 100UF 20% RLT
C420	157D-228M+5-X=I	CE 16V 2200UF 20% RL
C421	157E-108M+K-S9I	CE 25V 1000UF 20% RLT
C701	150F-473K+2-GD	CC 50V 0.047UF 10% AT
C702	157D-106M+K-IUI	CE 16V 10UF 20% RLT 5X11
C706	150F-104K+K-II	CC 50V 0.1U 10% RLT 5x5
C707	153F-102J+K-IM	CM 50V 1000P 5% RLT 5x7
C709	157B-107M+K-IUI	CE 6.3V 100UF 20% RLT
C901 *EU	150F-223K+2-FD	CC 50V 0.022uF 10% AT
C902, C903	150F-223K+2-FD	CC 50V 0.022uF 10% AT
C904	157D-106M+K-IUI	CE 16V 10UF 20% RLT 5X11
C906	157D-107M+K-IUI	CE 16V 100UF 20% RLT
C907	157D-477M+K-OVI	CE 16V 470UF 20% RLT
C911	150F-200J+2-FC	CC 50V 20pF 5% AT 3.5x2
C912, C913	150F-102K+2-FC	CC 50V 1000pF 10% AT 3.5
C914, C915	150F-101K+2-FC	CC 50V 100pF 10% AT 3.5x
C916	150F-331K+2-FC	CC 50V 330pF 10% AT 3.5x
C924	15CH-270J+5-GG	CTC 0/60 27pF 5% RL 4x4
C925	15CH-200J+5-GG	CTC 0/60 20pF 5% RL 4x4

Location	Part Number	Description
C926	153F-333J+K-NLM	CM 50V 0.033U 5% RLT 7.5
C927	157F-225M+K-IUI	CE 50V 2.2U 20% RLT
C928	157D-106M+K-IUI	CE 16V 10UF 20% RLT 5X11
C929	157F-224M+K-IUI	CE 50V 0.22UF 20% RLT
C930	150F-223K+2-FD	CC 50V 0.022uF 10% AT
C931	157B-107M+K-IUI	CE 6.3V 100UF 20% RLT
C932, C941	150F-223K+2-FD	CC 50V 0.022uF 10% AT
C942	157D-228M+5-X=I	CE 16V 2200UF 20% RL
C943	157F-225M+K-IUI	CE 50V 2.2U 20% RLT
C944	157F-475M+K-IUI	CE 50V 4.7UF 20% RLT
C945	150F-101K+2-FC	CC 50V 100pF 10% AT 3.5x
C946	157F-105M+K-IUI	CE 50V 1UF 20% RLT 5X11
C947	157F-474M+K-IUI	CE 50V 0.47UF 20% RLT
C948	157F-105M+K-IUI	CE 50V 1UF 20% RLT 5X11
C949, C950	150F-223K+2-FD	CC 50V 0.022uF 10% AT
C951	157F-475M+K-IUI	CE 50V 4.7UF 20% RLT
C953, C954	153F-272J+K-MMN	CM 50V 2700PF 5% RLT 7X7
C959, C960	157D-226M+K-IUI	CE 16V 22UF 20% RLT 5X11
C961, C962 *CA	153F-272J+K-MMN	CM 50V 2700PF 5% RLT 7X7
C961, C962 *EU	153F-152J+K-JM	CM 50V 1500P 5% RLT
C963, C964	157D-226M+K-IUI	CE 16V 22UF 20% RLT 5X11
C965	153F-272J+K-MMN	CM 50V 2700PF 5% RLT 7X7
C967	157F-474M+K-IUI	CE 50V 0.47UF 20% RLT
C968	150F-223K+2-FD	CC 50V 0.022uF 10% AT
C969	157D-476M+K-IUI	CE 16V 47UF 20% RLT
C970	150F-223K+2-FD	CC 50V 0.022uF 10% AT
C971	15CH-080D+5-GG	CTC 0/60 8pF 0.5pF RL
C973	153F-473J+5-NLM	CM 50V 0.047uF 5% RL 7.5
C974	150F-223K+2-FD	CC 50V 0.022uF 10% AT
C975	157D-106M+K-IUI	CE 16V 10UF 20% RLT 5X11
C976	150F-223K+2-FD	CC 50V 0.022uF 10% AT
C977	157F-225M+K-IUI	CE 50V 2.2U 20% RLT
C978	150F-223K+2-FD	CC 50V 0.022uF 10% AT
C979	157D-226M+K-IUI	CE 16V 22UF 20% RLT 5X11
C980	153F-224J+K-MIB	CM 50V 0.22U 5% RLT 7X5
C981	150F-223K+2-FD	CC 50V 0.022uF 10% AT
C982	150F-101K+2-FC	CC 50V 100pF 10% AT 3.5x
C983, C984	150F-223K+2-FD	CC 50V 0.022uF 10% AT
C985	150F-561K+K-IEA	CC 50V 560P 10% RLT 5x3
C986	157B-107M+K-IUI	CE 6.3V 100UF 20% RLT
C987	150F-223K+2-FD	CC 50V 0.022uF 10% AT
C988, C989	15CH-300J+5-IG	CTC 0/60 30pF 5% RL 5x4
C990	157B-107M+K-IUI	CE 6.3V 100UF 20% RLT

Location	Part Number	Description
C991	153F-102J+K-IM	CM 50V 1000P 5% RLT 5x7
C992	150F-103K+2-FC	CC 50V 0.01uF 10% AT 3.5
C995	150F-223K+2-FD	CC 50V 0.022uF 10% AT
C996	157D-107M+K-IUI	CE 16V 100UF 20% RLT
DIODE		
D202, D203, D204, D205, D207, D208, D209, D309	4804-1480+2	DIODE 1N4148T AT
D401, D402, D403, D404, D405, D406, D407, D408, D409	4804-0010+2	DIODE W1N4001-A(WA) AT
D410	4837-27V0+2	DZ 1/2W 27V(26.2-27.6)AT
D411, D412	4837-10D1+2	DZ 1/2W 9.94~10.44V ROHM
D701	4802-02K0+3	DIODE SW 80V 300MA
D901	4837-4C20+2	DZ 1/2W 5.0-5.2V AT
D980, D981	4804-1480+2	DIODE 1N4148T AT
Z202	4837-3V36+2	DZ 1/2W +-5% 3.3V TEMIC
Z203	4837-6B21+2	DZ 1/2W M5.96~6.27V ROHM
WAFER/CONNECTOR		
0205 *CA	2107-0641+0	ANT-TERMINAL F-TYPE
0205 *EU	2107-0681+0	ANT-TERMINAL (DIN-TYPE)
J202B	2101-1536+0	FFC CONNECTOR 15P P1.0
J401B	2102-081S+004	WAFER 8P P2.5 ST.
P901	2113-1160+0	WAFER 2P ST. P=2.5 NH
JACK/SCOKET		
J201	2113-1749+0	SOCKET DB9 D SUB RA
M302, M303	2113-1179+0	PHONE JACK D3.5 BK
M987	2113-1300+0	2P RCA JACK W/R AU
COIL		
J234, R912, R955 *CA	1801-101K+M	COIL 100UH 10%
J234, R912, R955 *EU	1801-101K+M-2	COIL 100UH 10% AT
J943	1801-101K+M-2	COIL 100UH 10% AT
L901	1801-220K+M-2	COIL 22UH 10% AT BL7
L903, L904	5600-3386+S	COIL MPX LPF NMC-4085
L905	1801-101K+M-2	COIL 100UH 10% AT
L941	5600-3396+S	COIL FM DET-1 10.7MHZ
L942	5600-3406+S	COIL FM DET-2 10.7MHZ
L971	5600-3280+G	COIL MW RF BLOCK
L972	5600-3416+S	COIL AM IFT NMIF-4062
L985	1801-101K+M-2	COIL 100UH 10% AT

Location	Part Number	Description
CRYSTAL		
M905	2300-0440+0	CRYSTAL 7.2MHZ 20PPM
M985	2300-1220+0	CRYSTAL 4.332MHZ
CERAMIC FILTERS		
M902, M904	2701-0010+1	CF10.7 +-30
M903 *EU	2701-0010+1	CF10.7 +-30
M911	2701-0680+0	CF 450 +-1
TRANSISTOR		
Q401, Q402	485A-950Y+K	TR 2SA950-Y HFE100-200
Q403	4860-0050+K	TR SS8050 C/D RLT
Q702	4851-9230+5	TR 2SC1923-0(Te2/F/T)
Q901 *EU	485C-945P+5	TR 2SC945P HFE 200-400
Q902	4851-9230+5	TR 2SC1923-0(Te2/F/T)
Q903	485A-114E+K	TR DTA114ESA RLT ROHM
Q922, Q923, Q942	4860-1590+K	TR 2SC1740STPR
Q943, Q944	4860-8120+G	TR 2SD1468S TPS ROHM
Q945	485A-114E+K	TR DTA114ESA RLT ROHM
Q980	485C-114E+K	TR DTC114ES RLT
Q981	485A-114E+K	TR DTA114ESA RLT ROHM
Q982	4853-63BL+5	TR N-JEET 2SK-363BL(F)
Q983, Q984	485C-114E+K	TR DTC114ES RLT
RESISTOR		
R201, R205	4701-472J+2	RCF 1/8W 4.7K 5% AT
R207	4701-223J+2	RCF 1/8W 22K 5% AT
R208, R209	4701-750J+2	RCF 1/8W 75R 5% AT
R212	4701-471J+2	RCF 1/8W 470R 5% AT
R213, R214	4701-472J+2	RCF 1/8W 4.7K 5% AT
R226	4701-101J+2	RCF 1/8W 100R 5% AT
R228	4701-471J+2	RCF 1/8W 470R 5% AT
R235, R236	4701-103J+2	RCF 1/8W 10K 5% AT
R401, R402	4701-102J+2	RCF 1/8W 1K 5% AT
R403	4701-100J+2	RCF 1/8W 10R 5% AT
R404	4701-102J+2	RCF 1/8W 1K 5% AT
R701	4701-152J+2	RCF 1/8W 1.5K 5% AT
R702	4701-331J+2	RCF 1/8W 330R 5% AT
R703	4701-303J+2	RCF 1/8W 30K 5% AT
R704	4701-102J+2	RCF 1/8W 1K 5% AT
R705	4701-103J+2	RCF 1/8W 10K 5% AT
R706	4701-153J+2	RCF 1/8W 15K 5% AT
R708	4701-472J+2	RCF 1/8W 4.7K 5% AT

Location	Part Number	Description
R723	4701-103J+2	RCF 1/8W 10K 5% AT
R901 *CA	4701-332J+2	RCF 1/8W 3.3K 5% AT
R901 *EU	4701-333J+2	RCF 1/8W 33K 5% AT
R902	4701-220J+2	RCF 1/8W 22R 5% AT
R903 *CA	4701-102J+2	RCF 1/8W 1K 5% AT
R903 *EU	4701-123J+2	RCF 1/8W 12K 5% AT
R904 *EU	4701-331J+2	RCF 1/8W 330R 5% AT
R905 *EU	4701-681J+2	RCF 1/8W 680R 5% AT
R906	4701-103J+2	RCF 1/8W 10K 5% AT
R907 *EU	4701-332J+2	RCF 1/8W 3.3K 5% AT
R908 *EU	4701-471J+2	RCF 1/8W 470R 5% AT
R909, R910	4701-331J+2	RCF 1/8W 330R 5% AT
R911	4701-101J+2	RCF 1/8W 100R 5% AT
R915	4701-103J+2	RCF 1/8W 10K 5% AT
R916	4701-102J+2	RCF 1/8W 1K 5% AT
R918	4701-472J+2	RCF 1/8W 4.7K 5% AT
R919, R920	4701-102J+2	RCF 1/8W 1K 5% AT
R921, R922	4701-222J+2	RCF 1/8W 2.2K 5% AT
R923, R924	4701-102J+2	RCF 1/8W 1K 5% AT
R925, R926	4701-820J+2	RCF 1/8W 82R 5% AT
R927	4701-103J+2	RCF 1/8W 10K 5% AT
R928	4701-221J+2	RCF 1/8W 220R 5% AT
R929	4701-222J+2	RCF 1/8W 2.2K 5% AT
R931	4701-220J+2	RCF 1/8W 22R 5% AT
R933	4701-223J+2	RCF 1/8W 22K 5% AT
R942	4701-472J+2	RCF 1/8W 4.7K 5% AT
R943	4701-822J+2	RCF 1/8W 8.2K 5% AT
R944	4701-104J+2	RCF 1/8W 100K 5% AT
R945	4701-103J+2	RCF 1/8W 10K 5% AT
R946	4701-332J+2	RCF 1/8W 3.3K 5% AT
R947, R948	4701-103J+2	RCF 1/8W 10K 5% AT
R949	4701-332J+2	RCF 1/8W 3.3K 5% AT
R950	4701-684J+2	RCF 1/8W 680K 5% AT
R951	4701-102J+2	RCF 1/8W 1K 5% AT
R952, R953	4701-223J+2	RCF 1/8W 22K 5% AT
R954	4701-103J+2	RCF 1/8W 10K 5% AT
R957, R958 *CA	4701-562J+2	RCF 1/8W 5.6K 5% AT
R957, R958 *EU	4701-392J+2	RCF 1/8W 3.9K 5% AT
R959, R960 *CA	4701-124J+2	RCF 1/8W 120K 5% AT
R959, R960 *EU	4701-274J+2	RCF 1/8W 270K 5% AT
R961, R962	4701-471J+2	RCF 1/8W 470R 5% AT
R963, R964	4701-104J+2	RCF 1/8W 100K 5% AT
R968	4701-102J+2	RCF 1/8W 1K 5% AT

Location	Part Number	Description
R969	4701-104J+2	RCF 1/8W 100K 5% AT
R972	4701-103J+2	RCF 1/8W 10K 5% AT
R973	4701-183J+2	RCF 1/8W 18K 5% AT
R974	4701-104J+2	RCF 1/8W 100K 5% AT
R975 *CA	4701-243J+2	RCF 1/8W 24K 5% AT
R975 *EU	4701-563J+2	RCF 1/8W 56K 5% AT
R978	4701-105J+2	RCF 1/8W 1M 5% AT
R981	4701-101J+2	RCF 1/8W 100R 5% AT
R983	4701-104J+2	RCF 1/8W 100K 5% AT
R984	4701-105J+2	RCF 1/8W 1M 5% AT
R985, R986, R987	4701-102J+2	RCF 1/8W 1K 5% AT
R988	4701-471J+2	RCF 1/8W 470R 5% AT
R989, R990	4701-103J+2	RCF 1/8W 10K 5% AT
R991	4701-473J+2	RCF 1/8W 47K 5% AT
R992	4701-682J+2	RCF 1/8W 6.8K 5% AT
R993, R997	4701-104J+2	RCF 1/8W 100K 5% AT
R999	4701-512J+2	RCF 1/8W 5.1K 5% AT
IC		
U201	3132-3561+0	IC MCU 16K FLASH P89
U203	3131-7250+0	IC AT24C08A-10PU 8K
U204	3131-9470+0	IC MAX232D SO16
U402	3130-8190+0	IC NJM78M56FA-#ZZZB
U701	3131-9330+0	IC QUAD 2INPUT EXCLUSIVE
U901	3130-8180+0	IC LA1837L-E AM/FM IF
U902	3131-9040+0	IC LC72723M-TLM-E RDS
U903	3131-3760+0	IC LC7218-E PLL FREQ
SVR		
R941	4756-2036+3-03	SVR H3 20K
R956	4756-1036+3-06	SVR 10K H3 7X7.6 RH0615C
TUNER		
M901	1300-0800+0	TUNER ENV17103G1 CE VER
MISCELLANEOUS		
	3000-9812+0	BLANK LABEL (5X10)
	3005-0360+2	RIBBON 60MMX600M TEC
M986	4131-7701+0	ANTENNA WASHER

Location	Part Number	Description
PSU ASSY		
PC BOARD		
EU	PCB-C42526+PSU	PCB ASSY PSU
CA	PCB-C425D6+PSU	PCB ASSY PSU
PCB		
	1725-859A+0000	PCB MAIN/KEY/DIS/PSU/LED
CAPACITOR		
C801 △	8910-0049+0	CAP400V 4700P
RESISTOR		
R801 *CA	4717-335J+2-S	RMF 1/2W 3.3M 5% AT UL
SWITCH		
0401	5200-3151+0-01	POWER SWITCH
MISCELLANEOUS		
GND *CA	4132-1061+0	SOLDER TAG
M801, M803, M804, M805, M806	4132-1071+0	TERMINAL PIN

- NOTE:**
- The components identified by △ mark are critical for risk of fire and electrical shock. Replace only with part number specified.
 - <*CA > : Canadian model only.
 - <*EU > : European model only.
 - Capacitors : CP-Polystyrene, CM-Mylar, CE-Electrolytic, CC-Ceramic, CTC-NPO.
 - Resistors : RMF-Metal Film, RCF-Carbon Film.

EXPLODED VIEW

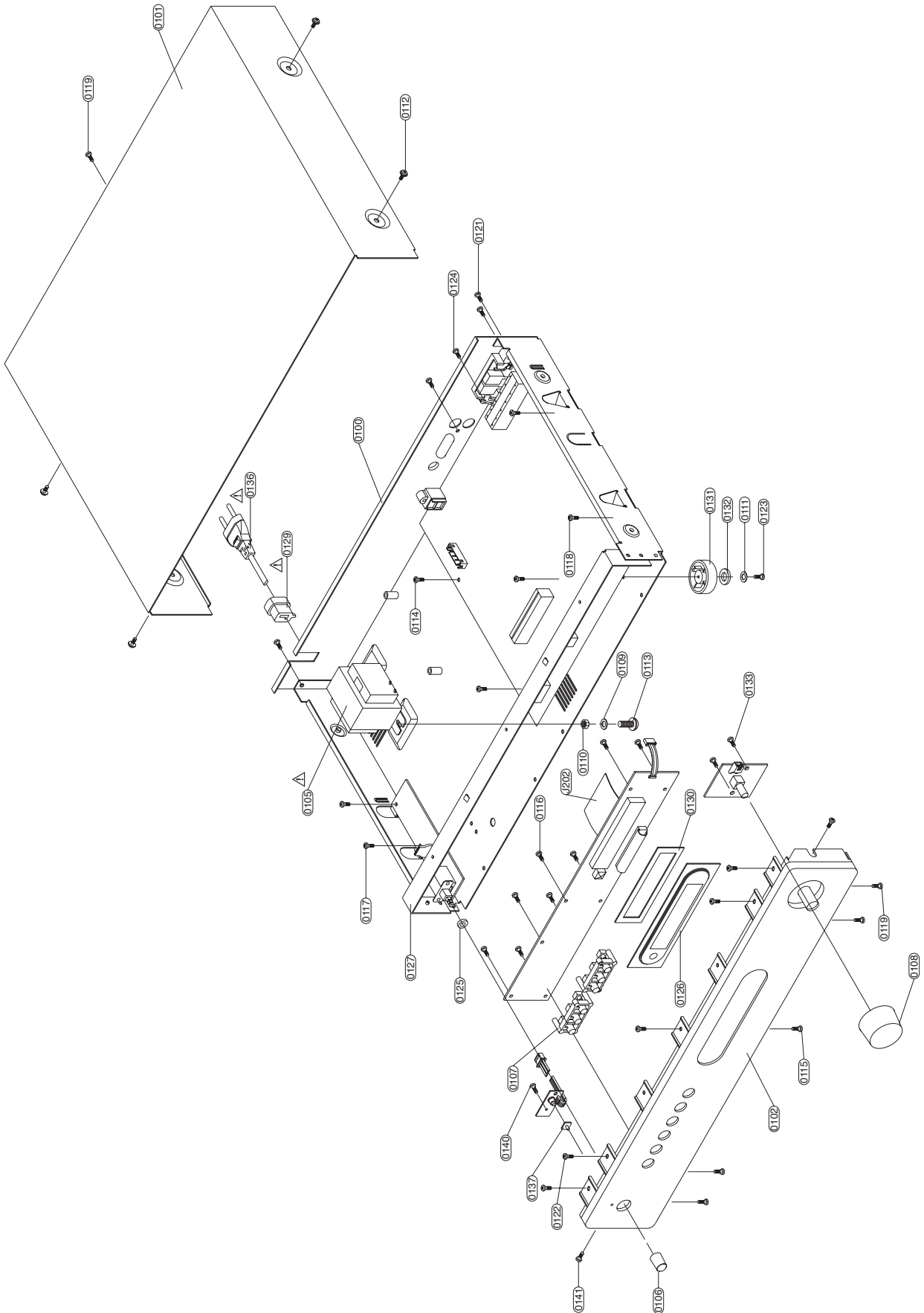

EXPLODED VIEW PARTS LIST

ITEM		PART NUMBER	DESCRIPTION
0100	*CA	1402-351F+2	CHASSIS AH NATNC425
0100	*EU	1402-351G+2	CHASSIS CE NATNC425
0101	TITA	1402-3532+0	TOP COVER SILVER (C542)
0101	GREY	1402-3533+0	COVER-TOP BLACK (C542)
0102	GREY	1466-5205+3	FASCIA BLACK NATNC425
0102	TITA	1466-5206+3	FASCIA SILVER NATNC425
0105	△	1806-3541+2	TRANSFORMER PWR 120/230V
0106	GREY	2442-1002+0	POWER BUTTON BLACK
0106	TITA	2442-1003+0	POWER BUTTON SILVER
0107	GREY	2444-1203+0	BUTTON TRIO BLACK
0107	TITA	2444-1204+0	BUTTON TR10 TITANIUM
0108	TITA	2446-6203+1	KNOB-VOLUME SILVER
0108	GREY	2446-6204+1	KNOB-VOLUME BLACK
0109		2600-4008+0973	FLAT WASHER 4*9.7*0.8
0110		2640-4030+0703	M4 NUT (BLK)
0111		2842-3367+0	METAL WASHER
0112	TITA	2900-4006+2010	SCM PW M4X6 RECESS WHITE
0112	GREY	2900-4006+3010	M4X0.5PX6MM W/FLAT
0113		2900-4010+3030	PH W/WASHER M4X10 BL ZN
0114		2904-3006+0000	SCREW M3X6
0115		2954-3006+3000	SCREW B-TITE BIND M3X6
0116, 0118		2954-3008+0000	SCREW B-TITE BIND M3X8
0117		2954-3006+0000	3X6MM B-TITE (YEL.ZN)
0119, 0121		2954-3008+3000	SCREW B-TITE BIND HEAD
0120	GREY	2954-3008+3000	SCREW B-TITE BIND HEAD
0120	TITA	2954-3010+4000	ST SCREW 3X10 BH
0122		2954-3008+0000	SCREW B-TITE BIND M3X8
0123, 0124		2954-3008+3000	SCREW B-TITE BIND HEAD
0125		2600-4008+0973	FLAT WASHER 4*9.7*0.8
0126		3716-4314+0	WINDOW LENS C420 W/SS
0127		1402-3783+2	STRAP (C542)
0128		4153-3331+0	EVA GASKET 5*500
0129	△	4152-3851+0	SQ. STRAIN RELIEF
0131		4157-0501+1	RUBBER FOOT
0132		4152-4641+1	CUSHION FOOT W/RUBBER WA
0133		2954-3008+0000	SCREW B-TITE BIND M3X8
0136	*CA △	7009-3100+2	AC CORD 18AWGX2

ITEM	PART NUMBER	DESCRIPTION
0136 *EU 	7009-3110+0	AC CORD (SEMKO)
0137	3714-5706+0	LED LENS (412) CLEAR SAN
0140, 0141	2954-3008+0000	SCREW B-TITE BIND M3X8
0146	2954-2006+0000	TAPPING SCREW 2X6
0160	2600-4008+0973	FLAT WASHER 4*9.7*0.8

- NOTE:**
- The components identified by  mark are critical for risk of fire and electrical shock. Replace only with part number specified.
 - <*CA > : Canadian model only.
 - <*EU > : European model only.

PACKING DIAGRAM

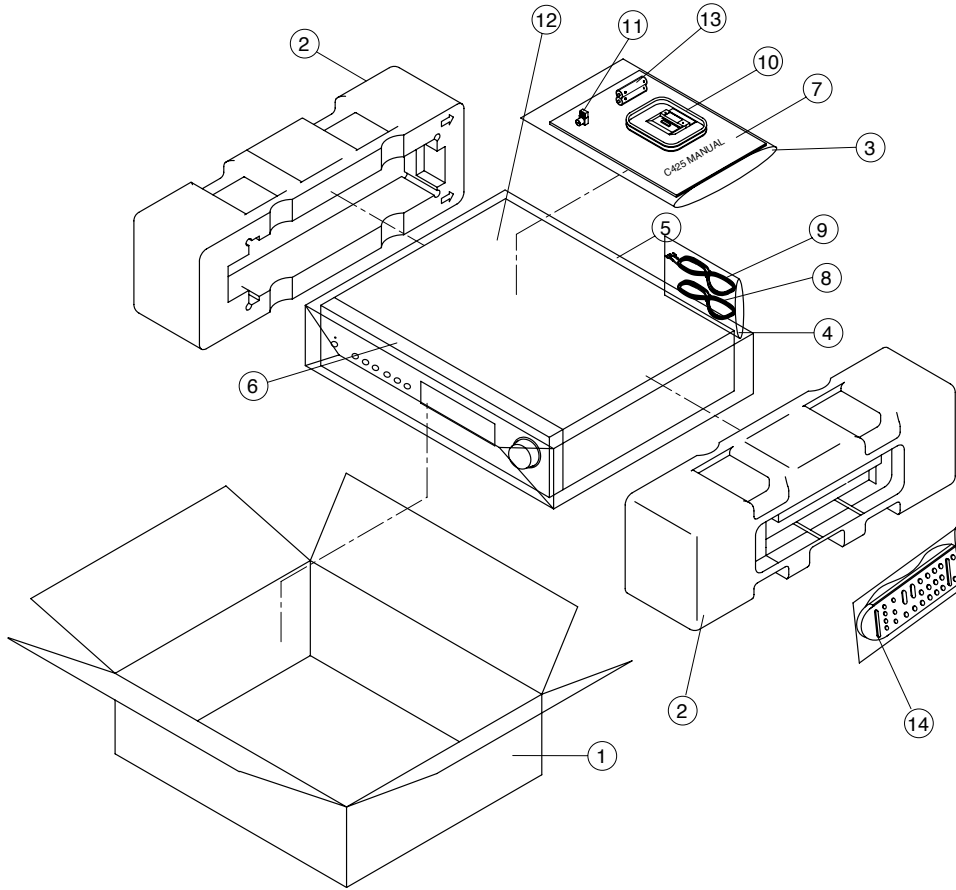

ITEM	PART NO.	DESCRIPTION	Q'TY
1	1437-8301+0-2	CARTON BOX C425	1
2	1490-3783+2	POLYFORM ENDCAP	2
3	1497-1062+0	POLYBAG MANUAL	1
4	1497-1302+0	POLYBAG	1
5	1497-1332+1	POLYBAG	1
6	1497-1432+0	EPE BAG (412)	1
7	4301-7238+0	INSTRUCTION MANUAL	1
8	2103-7302+1	RCA PLUG (MALE)	1
9	2107-0661+1	300-OHM T ANTENNA	1
10	2107-1131+0	AM LOOP ANTENNA	1
11	2103-6101+0	RF CONNECTION PLUG (F-TYPE)	1
12	1450-2520+0	WHITE PAPER	1
13	4060-0530+0	GREENCELL 3A SIZE GP24G2	2
14	8912-0055+0	REMOTE CONTROL NATNC425	1

Proprietary information for servicing purposes only. The information herein may not be used commercially without the prior written agreement of NAD Electronics International, Toronto, Canada.

SERVICE MANUAL

C 425

STEREO
AM/FM TUNER

© NAD 2006

NAD ELECTRONICS INTERNATIONAL
TORONTO