

SERVICE MANUAL
SERVICE MANUAL

C 520
COMPACT
DISC PLAYER

C 520
COMPACT
DISC PLAYER

C 520
COMPACT
DISC PLAYER

© NAD 1999

NAD ELECTRONICS LTD
LONDON



SAFETY INFORMATION

CAUTION

<p>CAUTION - INVISIBLE LASER RADIATION WHEN OPEN AND INTERLOCKS DEFEATED. AVOID EXPOSURE TO BEAM.</p> <p>ADVARSEL - USYNLIG LASERSTRÅLING NÅR DEKSEL ÅPNEES OG SIKKERHEDSLÅS BRYTES. UNNGÅ EKSPONERING FOR STRÅLEN.</p> <p>ADVARSEL - USYNLIG LASERSTRÅLING VED ÅRNING, NÅR SIKKERHEDSAFBRYDERE ER UDE AF FUNKTION. UNDGÅ UDSÆTTELSE FOR STRÅLING.</p>	<p>VARING - OSYNLIG LASERSTRÅLING NÅR DENNA DEL ÄR ÖPPNAD OCH SPÄRRAR ÄR URKOPPLADE. STRÅLEN ÄR FARLIG.</p> <p>VARO! - AVATTAESSA JA SUOJALUKITUS OHITETTAESSA OLET ALLTTIINA NÄKTMÄTÖNTÄ LASERSÄTELYLLE. ÄLÄ KAISO SÄTTESEEN.</p> <p>VORSICHT! - UNSICHTBARE LASERSTRAHLUNG TRITT AUS, WENN DECKEL GEÖFFNET UND WENN SICHERHEITSPERRREGELUNG ÜBERBRÜCKT IST. NICHT DEM STRAHL AUSSETZEN.</p>
---	--

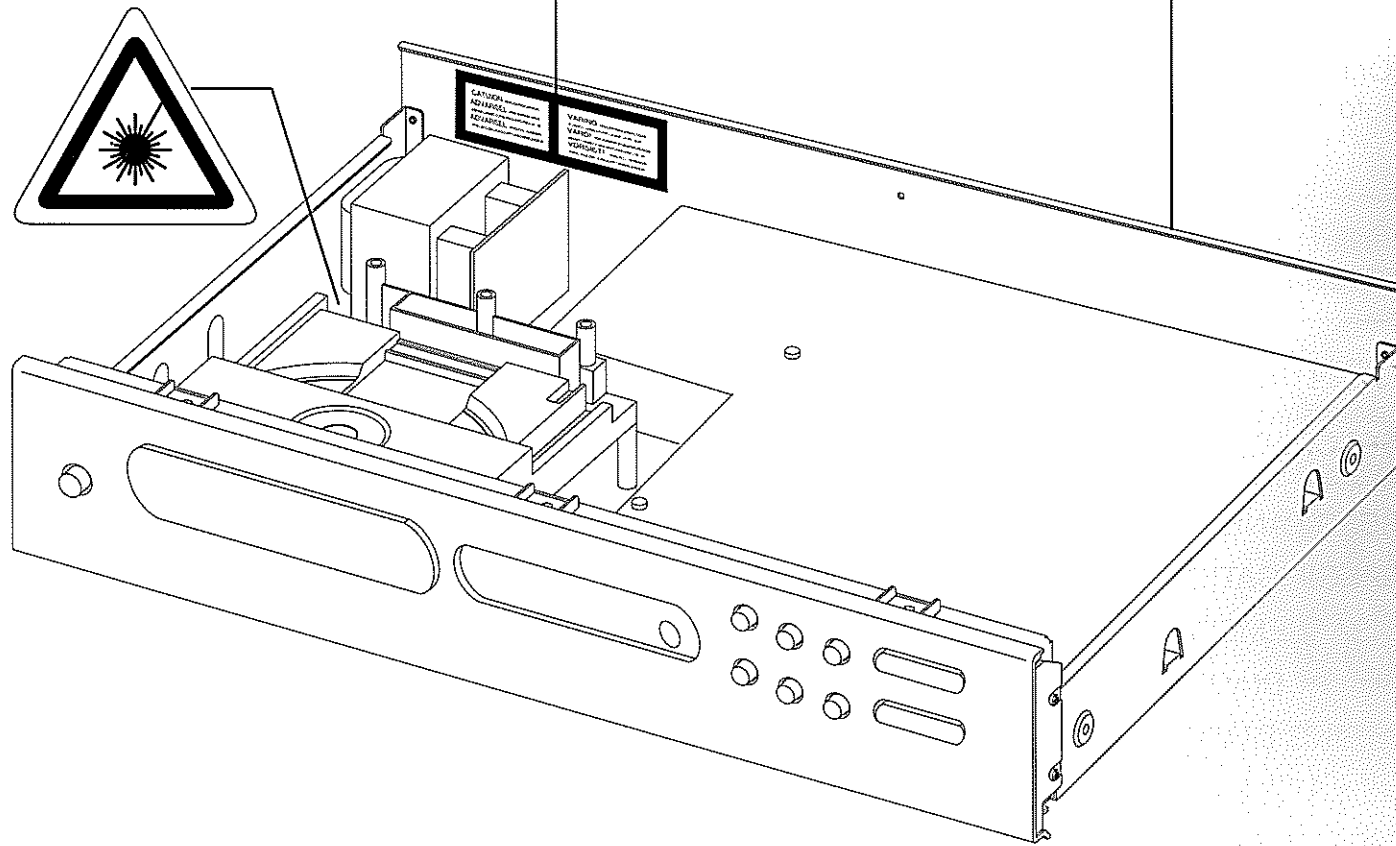
**CLASS 1
LASER PRODUCT**



<p> The lightning flash with arrowhead, within an equilateral triangle is intended to alert the user of the presence of uninsulated "dangerous voltage" within the product's enclosure; that may be of sufficient magnitude to constitute a risk of electric shock to persons.</p>	<p> The exclamation point within an equilateral triangle is intended to alert the user of the presence of important operating and maintenance (servicing) instructions in the literature accompanying the appliance.</p>
--	---

THIS DEVICE COMPLIES WITH PART 15 OF THE FCC RULES. OPERATION IS SUBJECT TO THE FOLLOWING TWO CONDITIONS :-
 (1) THIS DEVICE MAY NOT CAUSE HARMFUL INTERFERENCE, AND
 (2) THIS DEVICE MUST ACCEPT ANY INTERFERENCE RECEIVED, INCLUDING INTERFERENCE THAT MAY CAUSE UNDESIRE OPERATION.

SERVICE SAFETY PRECAUTIONS

1. Replacing the fuses

CAUTION: FOR CONTINUED PROTECTION AGAINST THE RISK OF FIRE REPLACE ONLY WITH SAME TYPE OF FUSE.

Reference No	Part Number	Description
M502*AH - M504*AH	5120-0020-0	Fuse 1A 250V Time Lag (UL/CSA)
M505*AH	5120-0052-0	Fuse 1.6A 250V Time Lag (UL/CSA)
M502*C - M504*C	5120-0018-0	Fuse 1A 250V Time Lag (SEMKO/VDE)
M505*C	5120-0050-0	Fuse 1.6A 250V Time Lag (SEMKO/VDE)

NOTE :

- <*AH > : USA, CANADIAN MODEL ONLY.
- <*C > : EUROPEAN MODEL ONLY.

2. Safety check out

(Only U.S.A. model)

Before returning the product to the customer, make leakage current or resistance measurements to determine that exposed parts are acceptably insulated from the supply circuit.

Parts marked with the symbol  are critical with regard to the risk of fire and electric shock. Replace only with parts recommended by the manufacturer.

CONTENTS

DESCRIPTION	PAGE
REAR PANEL / FRONT PANEL VIEW	4
SPECIFICATIONS	5
DISASSEMBLY INSTRUCTIONS	6
BLOCK DIAGRAM	7
WIRING DIAGRAM	8
RF PATTERN TESTING	9
IMPORTANT NOTES	10 -11
PCB LAYOUT	12 -14
SCHEMATIC DIAGRAM	15 -16
IC BLOCK DIAGRAM	17 -19
TROUBLESHOOTING GUIDE	20
ELECTRICAL PARTS LIST	21-23
MECHANISM EXPLODED VIEW	24
MECHANISM EXPLODED VIEW PARTS LIST.....	25
EXPLODED VIEW	26
EXPLODED VIEW PARTS LIST	27
PACKING DIAGRAM	28

REAR PANEL / FRONT PANEL VIEW

REAR PANEL

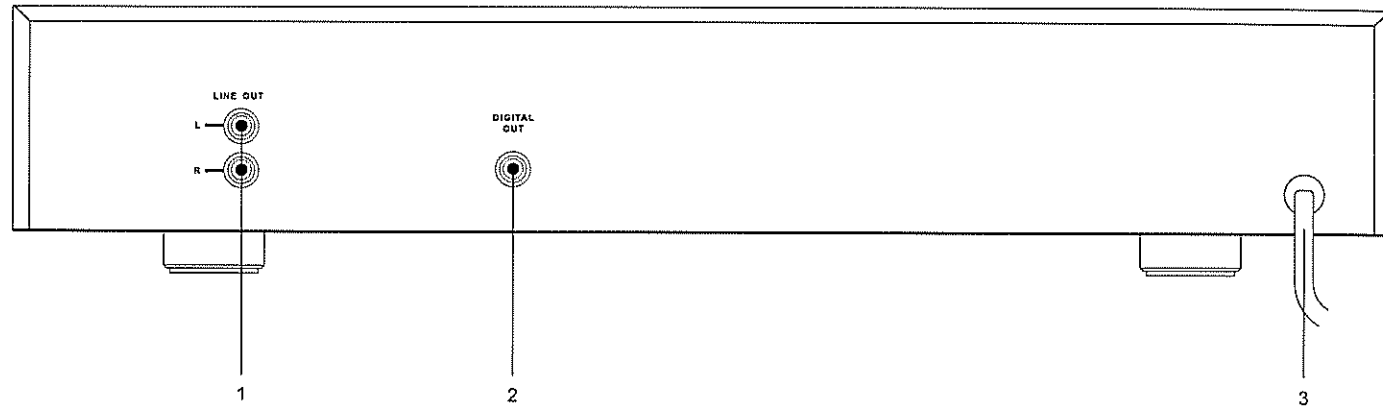

1. LINE OUTPUT
2. DIGITAL OUTPUT

3. AC LINE CORD

FRONT PANEL

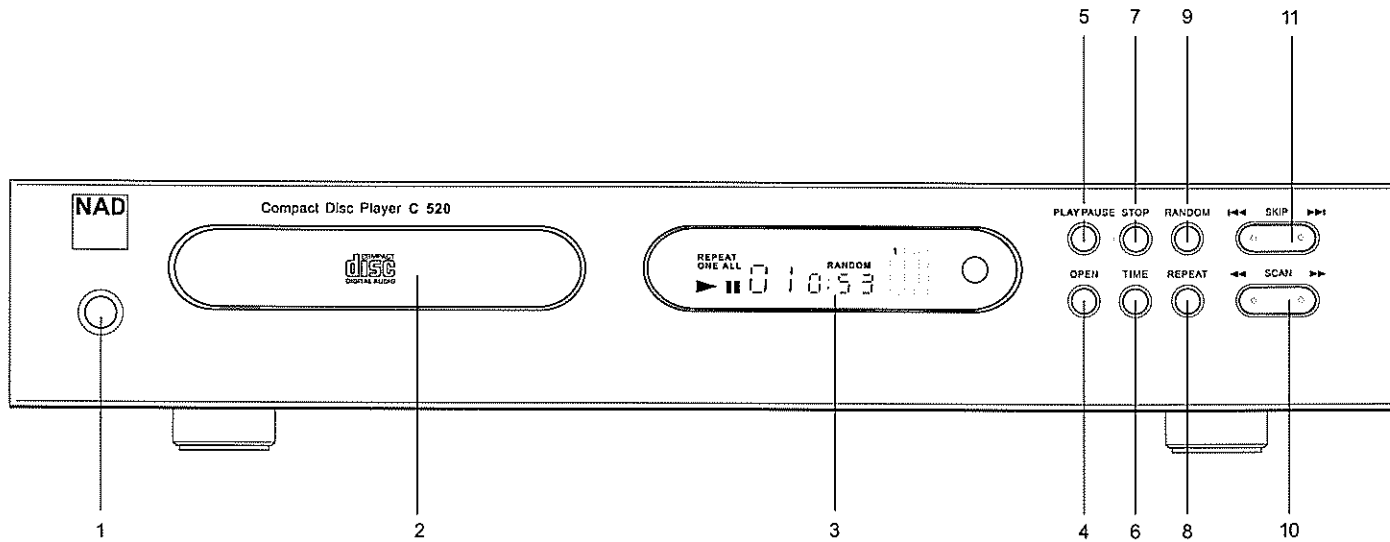

1. POWER ON / OFF
2. DISC DRAWER
3. DISPLAY
4. OPEN
5. PLAY / PAUSE
6. TIME

7. STOP
8. REPEAT
9. RANDOM
10. SCAN Back (◀◀) / Forward (▶▶)
11. SKIP Back (◀◀) / Forward (▶▶)

SPECIFICATIONS

Disc Capacity	One Disc, 120 or 80 mm
Decoding	BURR-BROWN Delta Sigma 20 bit
Digital Filter	8 Times oversample
Analog Filter	4 pole active
Frequency Response	+/- 0.5 dB, 5 Hz - 20 kHz
De-Emphasis Error	+/- 0.3 dB
THD (at 0 dB, 1 kHz)	0.007%
Intermodulation Distortion	< -100 dB
(19 + 20 kHz)	
Dynamic Range	96 dB
Linearity	+/- 0.5 dB, 0 dB to -80 dB
Signal / Noise Ratio (A-Weighted)	≥100 dB, De-Emphasis on
	≥100 dB, De-Emphasis off
Channel Separation 1 kHz	> 90 dB
10 kHz	> 80 dB
Wow and Flutter	Unmeasurable (Quartz Crystal Accuracy)
Output Impedance	200 Ω
Output level at 0 dB	2.2 V rms
Digital Error Correction	CIRC with double error correction
	in C1 and C2
Digital Code Output	Sony / Philips Serial data format

CONTROLS

Play / Pause, Stop, Random, Skip (< >), Scan (< >), Open, Time, Repeat.

PHYSICAL SPECIFICATIONS

Dimensions (Width x Height x Depth)	435 x 80 x 285 mm
Net weight	4 kg (8.8 lbs)
Shipping weight	5.1 kg (11.22 lbs)

DISASSEMBLY INSTRUCTIONS

1. Remove machine screws M 4.0 x 6.0 (① to ④) from the side panels. Remove tapping screw 3.0 x 8.0 (⑤) from the back panel. Refer to **Figure No. 1**.

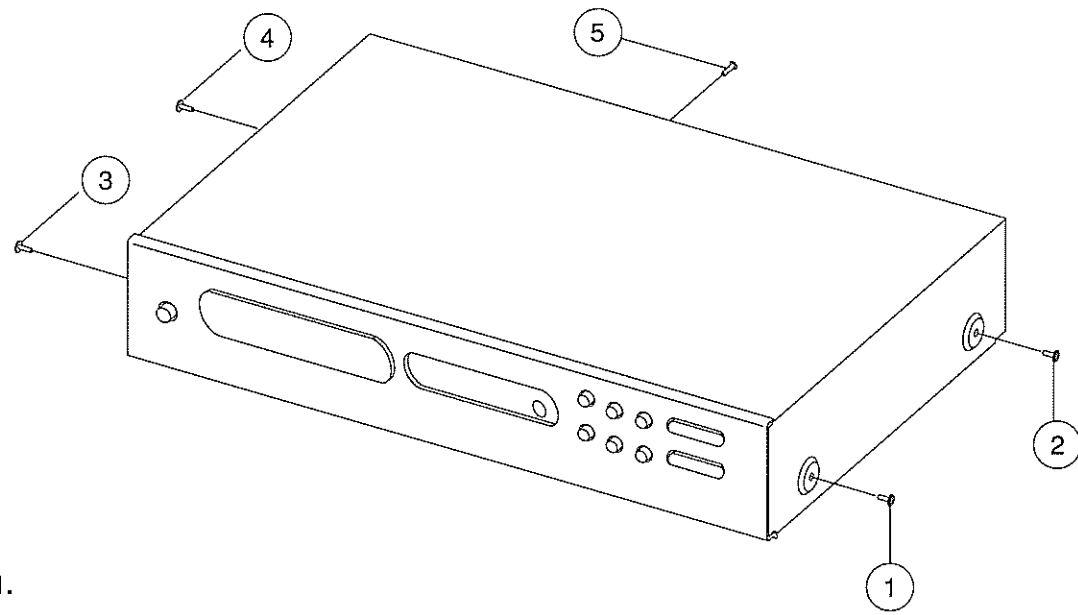

Figure No. 1.

2. Pull both sides of the TOP COVER slightly outwards (⑥) and tilt approx. 35° and then remove in the direction as indicated by the arrow (⑦). Refer to **Figure No. 2**.

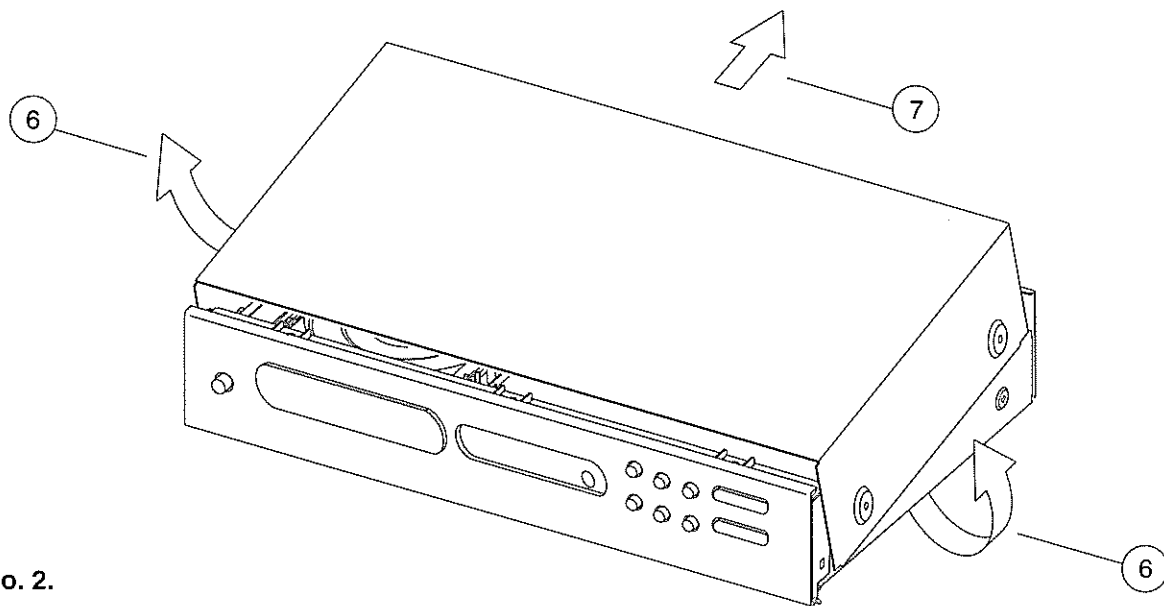
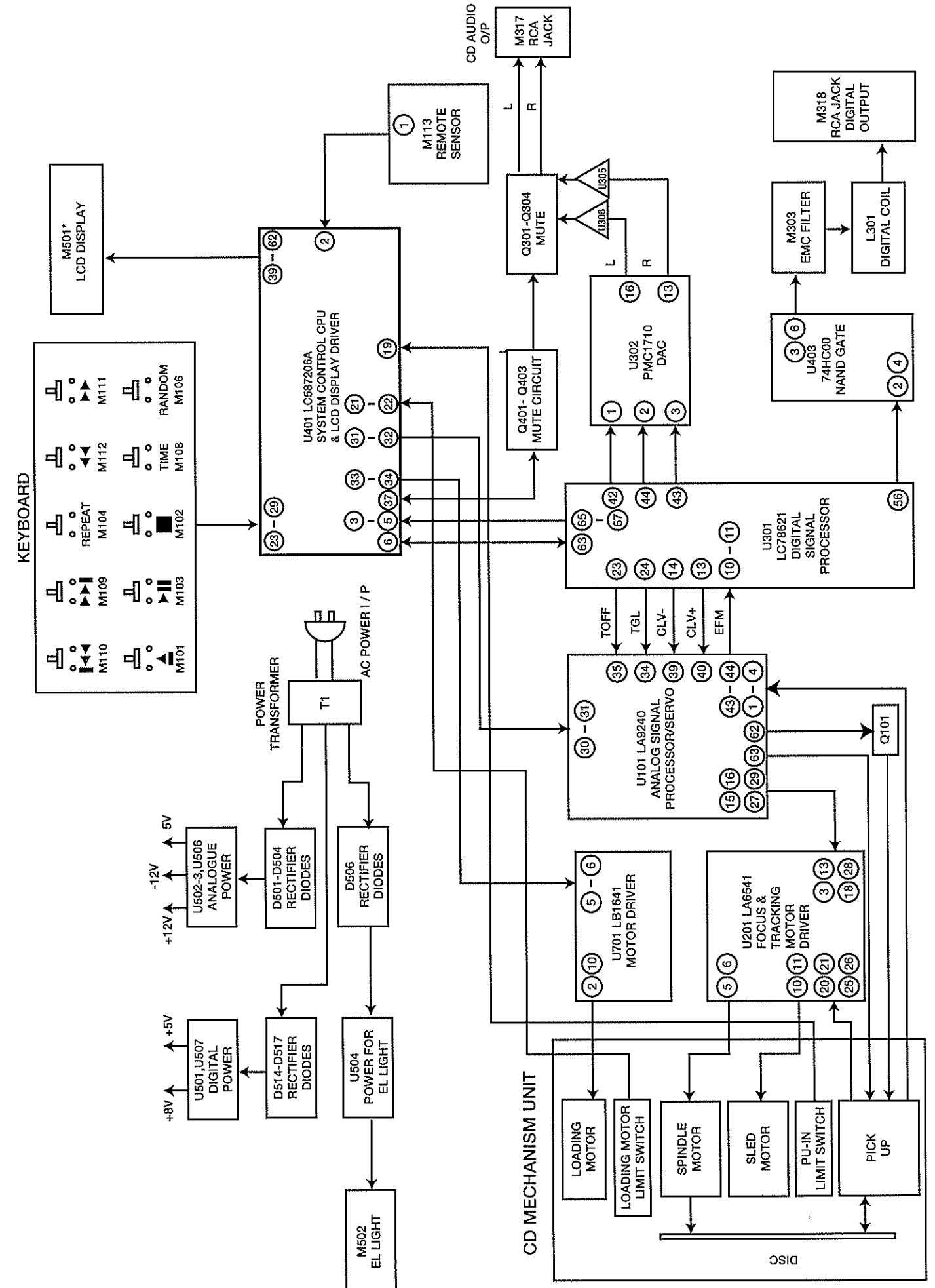
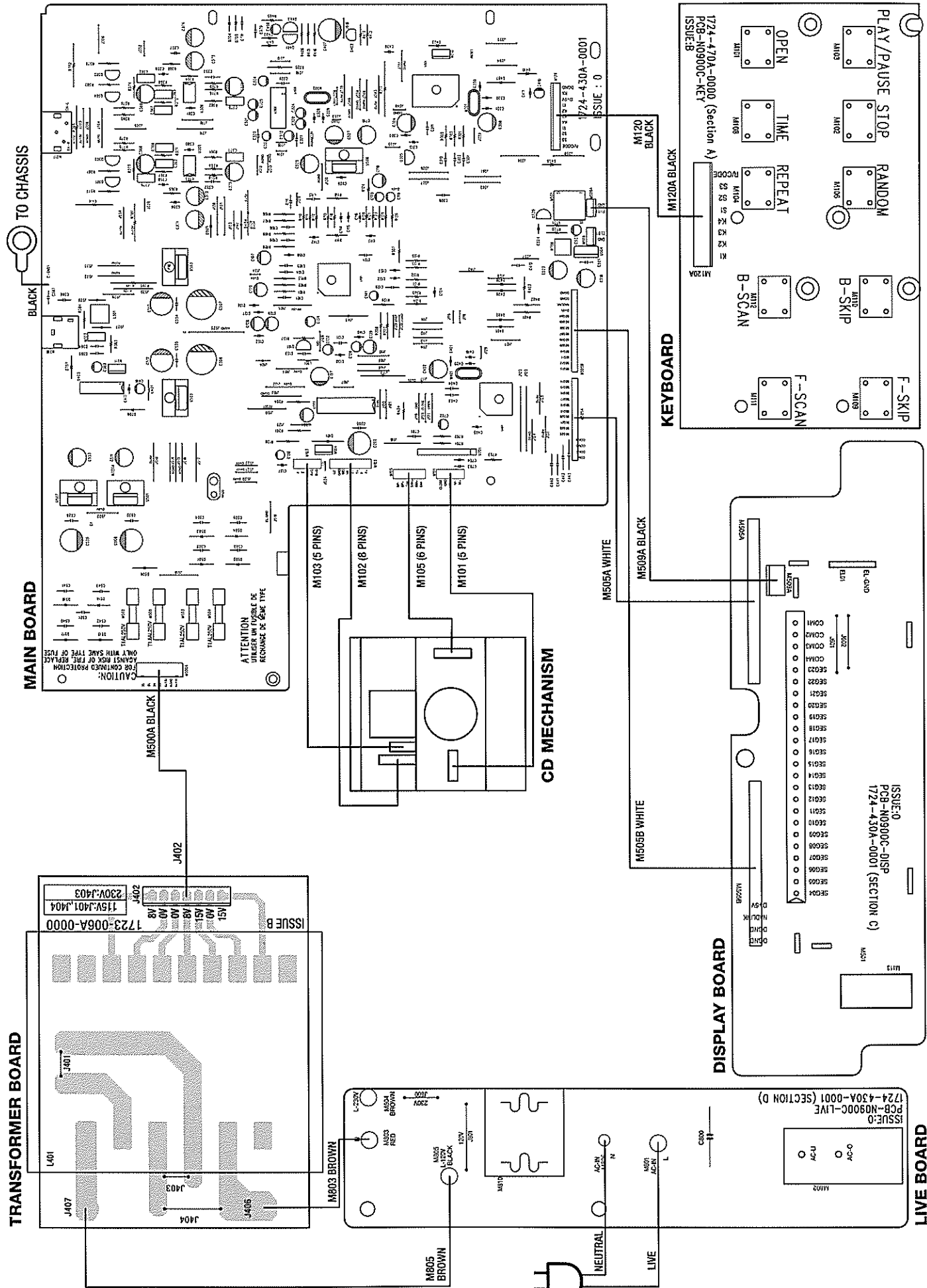

Figure No. 2.

BLOCK DIAGRAM



WIRING DIAGRAM



RF PATTERN TESTING

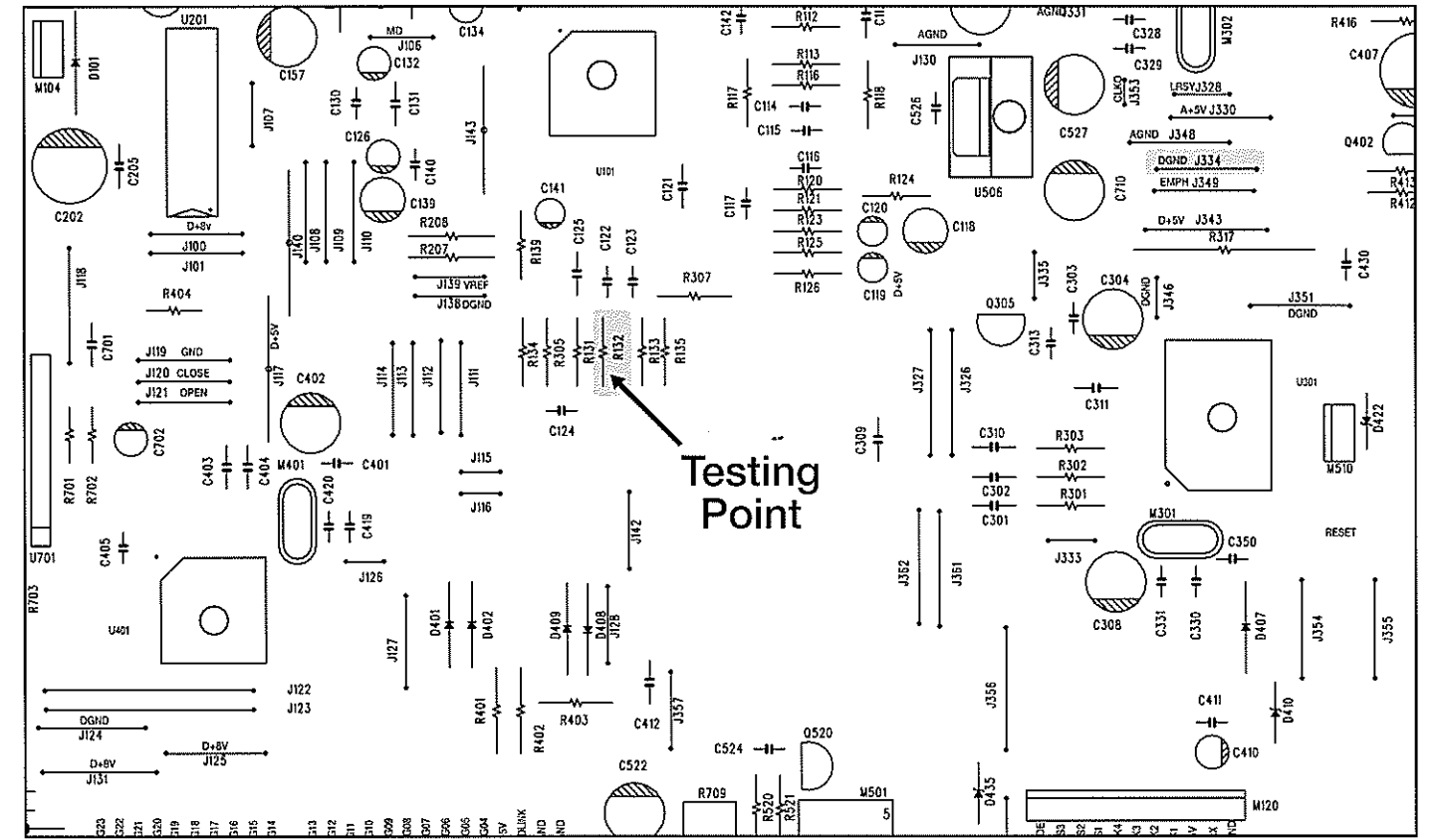

NAD - C 520 PCB TESTING POINTS DIAGRAM

TESTING PROCEDURE

- (1) Load the test disc (Sony Test CD YEDS-7) and set the unit into PLAY mode.
- (2) Connect the scope to R132 (Pin 41 of U101) and DGND (J334).
Scope setting: Coupling : AC.
 Vertical sensitivity : 0.2 V/div.
 Horizontal time base : 0.5 μ S/div.
- (3) Observe the waveform is 2.0V p-p +/- 5% and the eye pattern is at its best shape (see FIG. 1).

FIG. 1 (a)

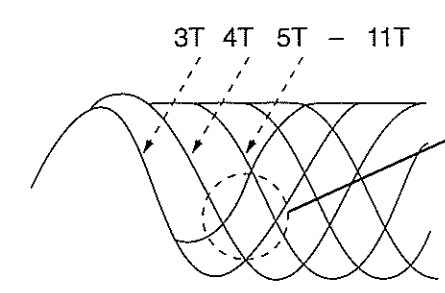

FIG. 1 (b) Poor eye pattern

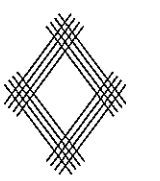
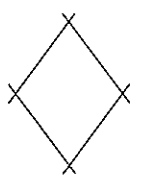

FIG. 1 (c) Good eye pattern



IMPORTANT NOTES

INSTRUCTION FOR HANDLING OPTICAL SYSTEM BLOCK PICK-UP

Electrostatic breakdown of the laser diode in the optical system block may occur due to a potential difference caused by electrostatic charge accumulated on clothing, human body, etc. A ground must be provided as follows to prevent any electrostatic charge during unpacking or repair work.

1. Ground for Human Body

Be sure to wear a ground band (1M ohm) that is properly grounded to remove any static electricity that may be charged on the body.

2. Ground for Work Bench

Be sure to place a conductive sheet (1M ohm) or copper plate with proper grounding on the work bench or other surface on which the pick-up is to be placed.

3. Because the static electricity charge on the clothing does not discharge through the body grounding band, do not let clothing to get in contact with the pick-up unit.

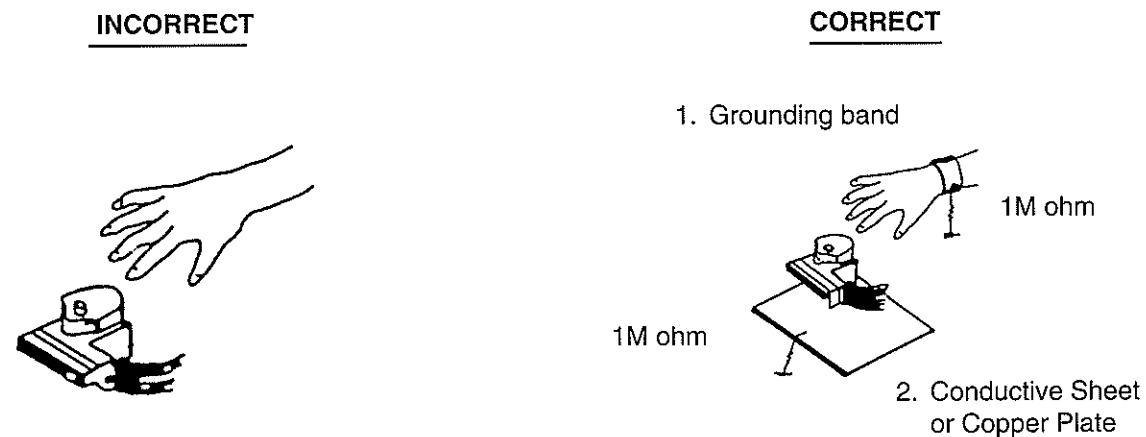

NOTE: Laser diodes are so susceptible to damage from static electricity that even if a static discharge does not ruin the diode, it can shorten its life or cause it to work improperly.

PRECAUTIONS FOR CHECKING BEAM EMISSION

The laser beam of this unit is focused on the reflecting surface of the objective lens in the optical system block. Therefore, keep your eyes at least 12 inches (30 cm) away from the objective lens when the laser diode is **ON**.

(Operation Check Method for Laser Diode and Focus Search Function.)

When the **POWER** switch is turned **ON** after the chucking plate is removed, observe the objective lens and confirm that the following operations are performed properly.

(The optical system block should be at the lead-in area position when it is checked at this time.)

(1) The laser should be at the innermost position after the chucking plate is removed.

(2) The diffused light of the laser beam can be seen when the **POWER** switch is turned **ON**.

(3) Vertical (up and down) movement of the objective lens (4 times) will take place.

PRECAUTIONS WHEN CHANGING LASER PICK-UP

When removing the pick-up assembly, short circuit the PCB tracks on the optical block as shown in the drawing in order to protect the pick-up before removal.

NOTE: Replacement pickup assemblies are supplied with the PCB pattern already protected.

DO NOT REMOVE THE SHORT CIRCUITS UNTIL YOU HAVE FINISHED FITTING THE PICK-UP.

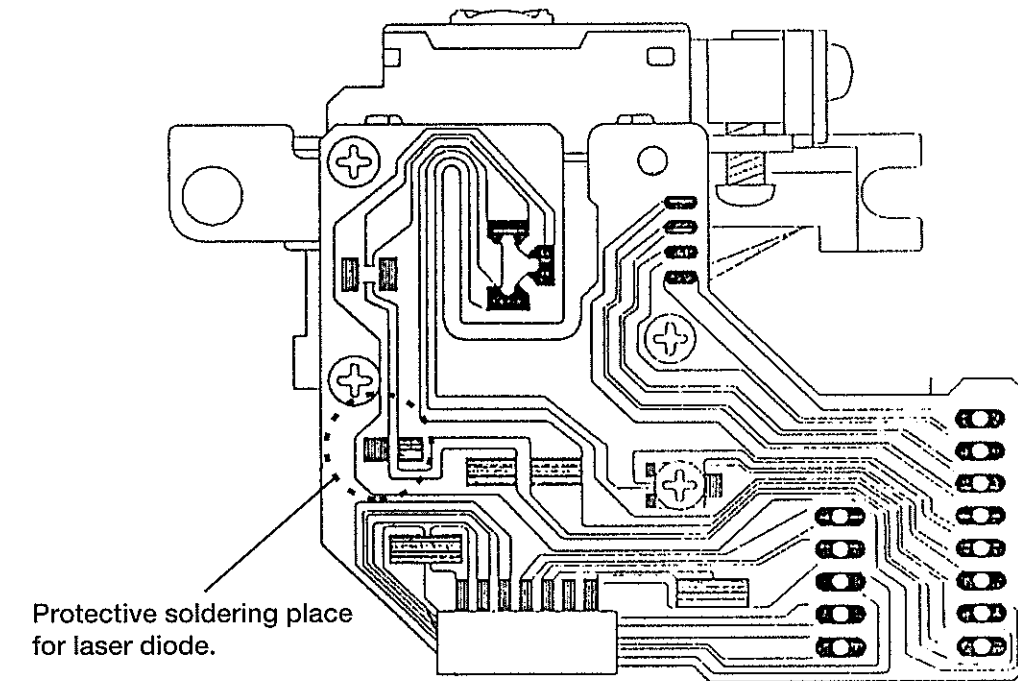

Caution:

Laser diodes are extremely susceptible to damage from static electricity. Even if a static discharge does not ruin the diode, it can shorten its life or cause it to work improperly. When replacing the pick-up, use a conductive mat, a grounded soldering iron, and so on, to protect the laser diode from static damage.

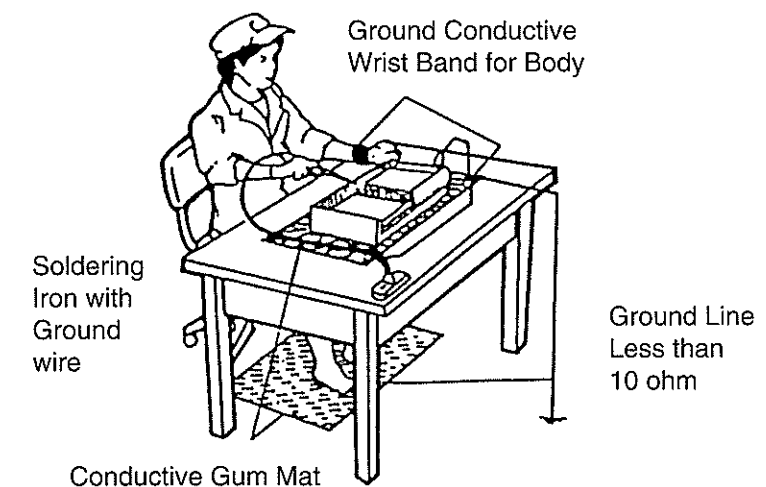

PCB LAYOUT

TRANSFORMER BOARD

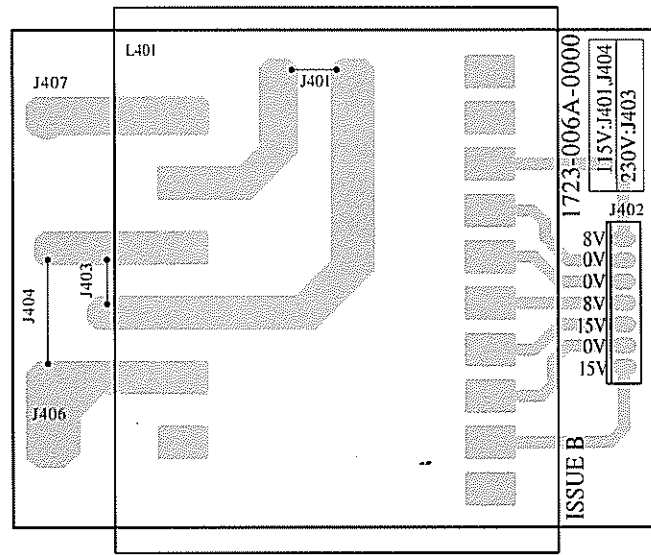

LIVE BOARD

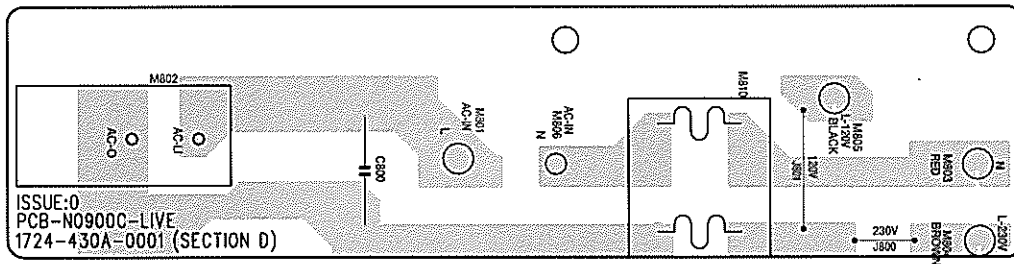

KEYBOARD

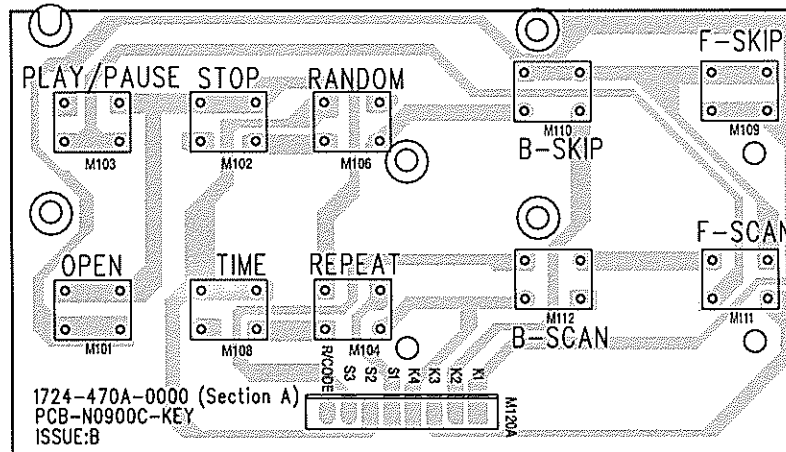

DISPLAY BOARD

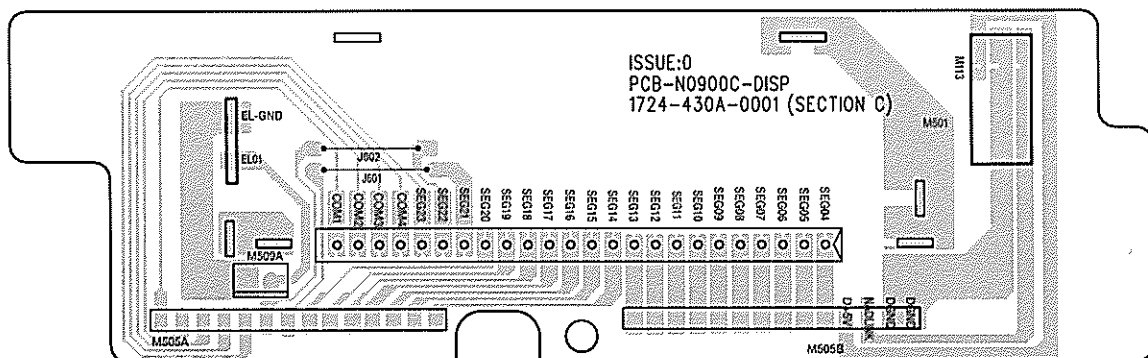

MAIN BOARD

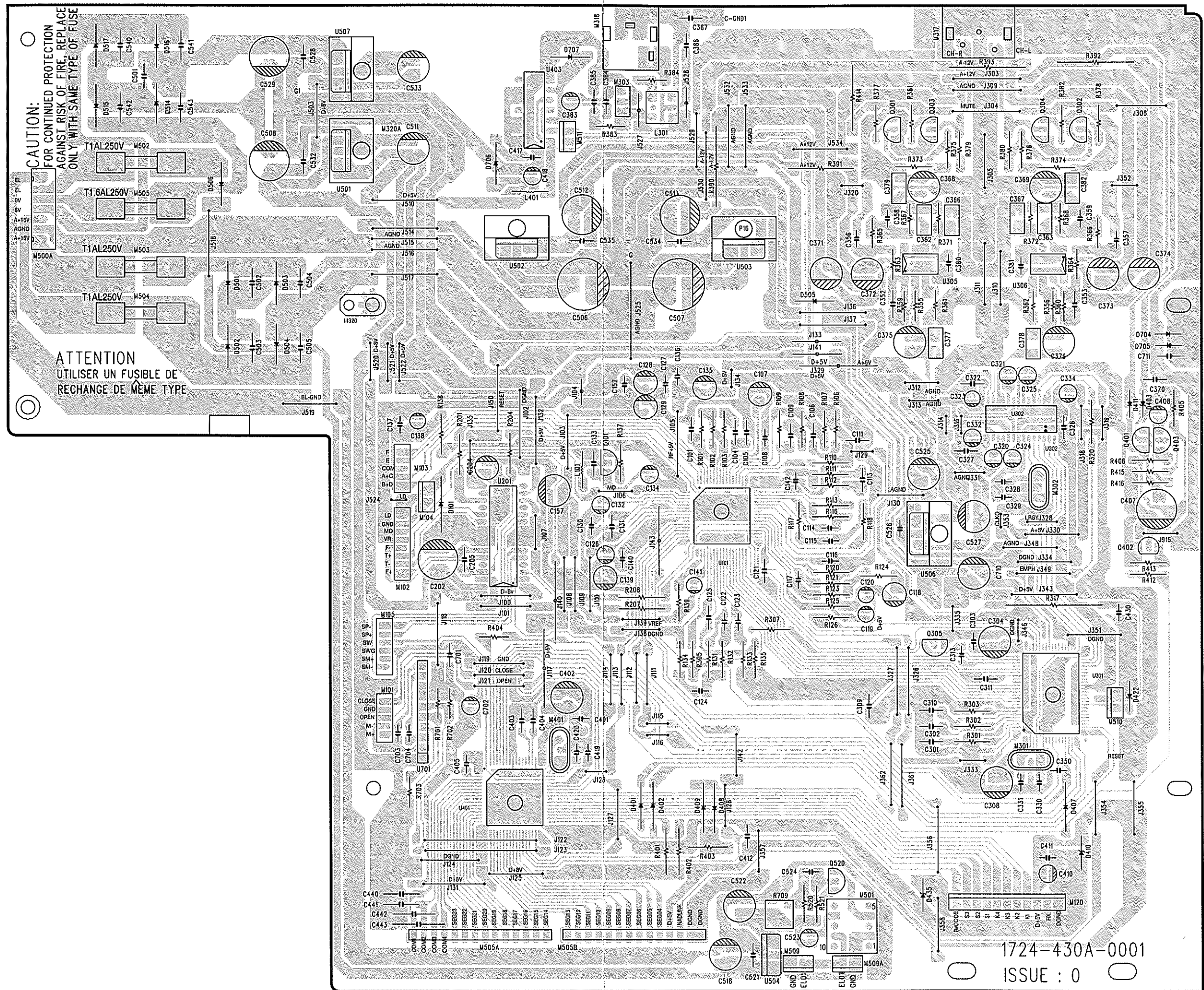

SCHEMATIC DIAGRAM

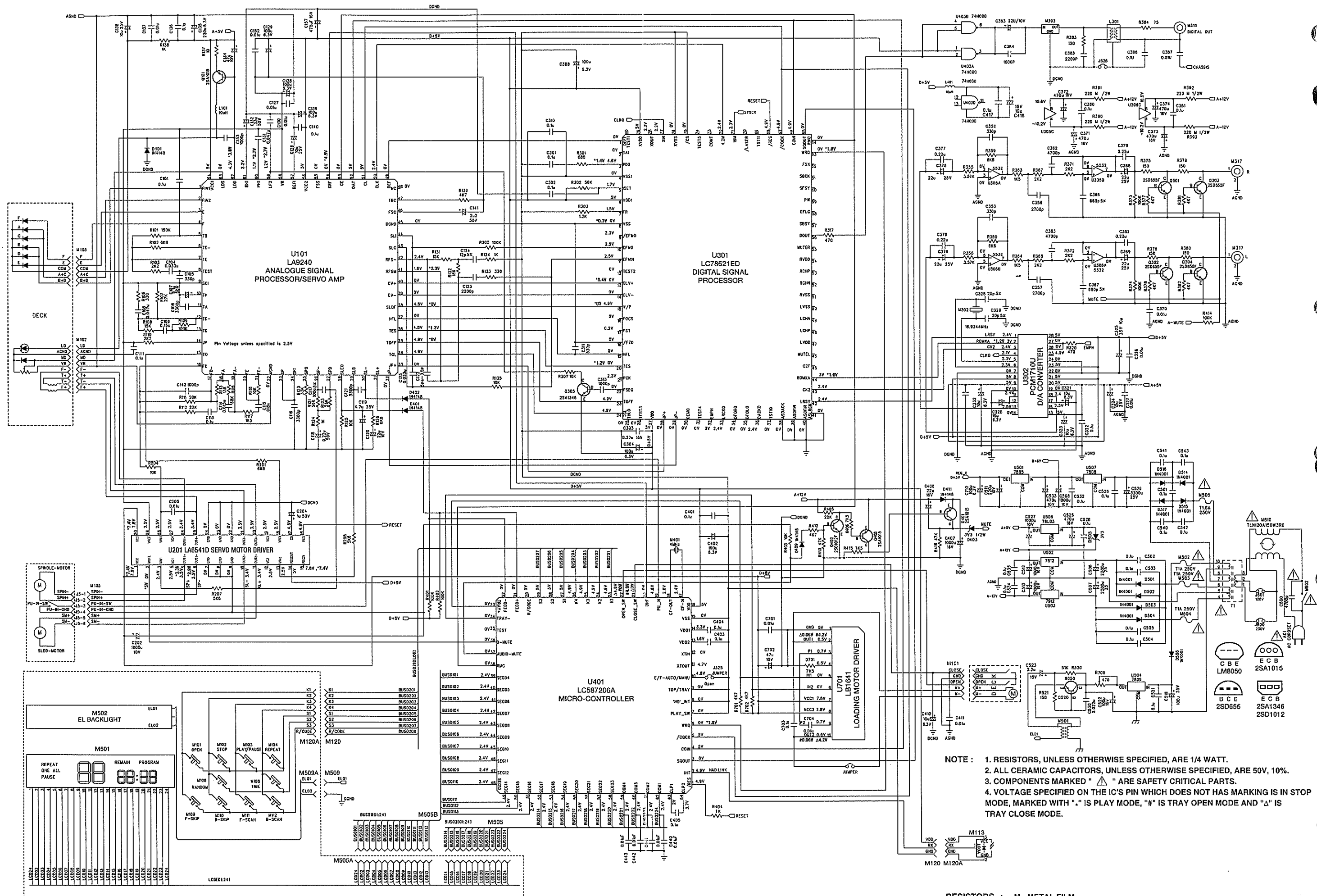

IC BLOCK DIAGRAM

U101: LA9240

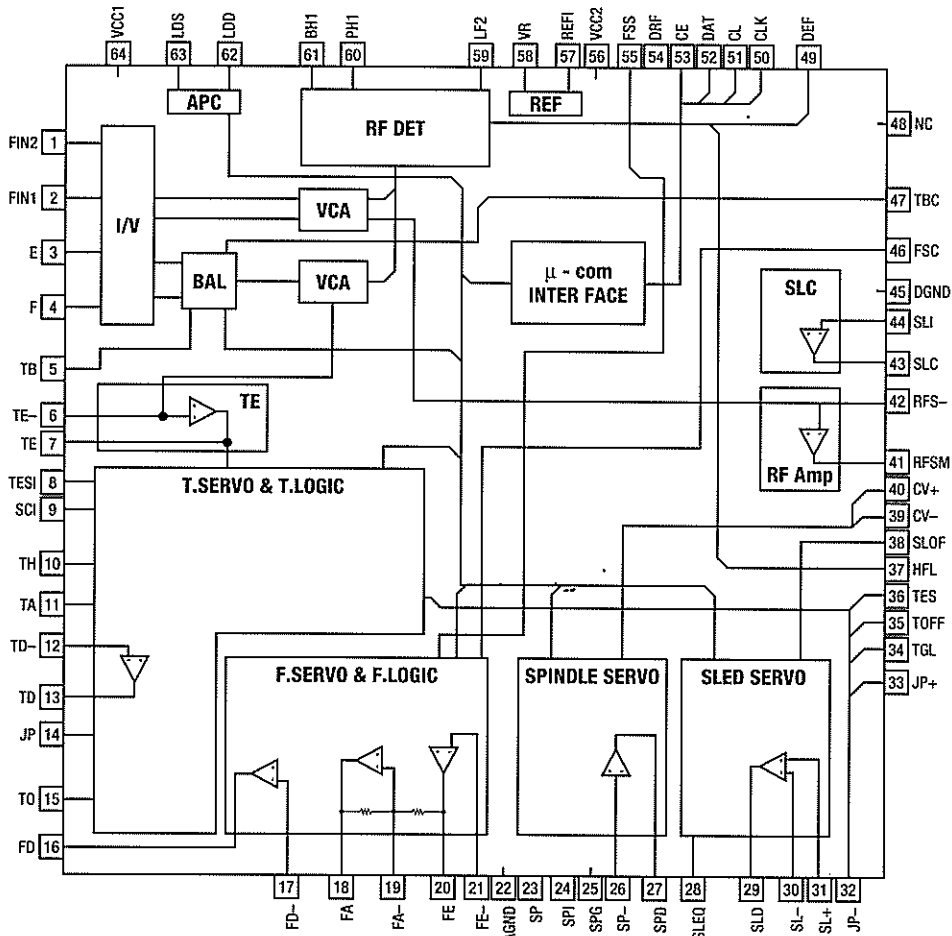

U301: LC78621ED

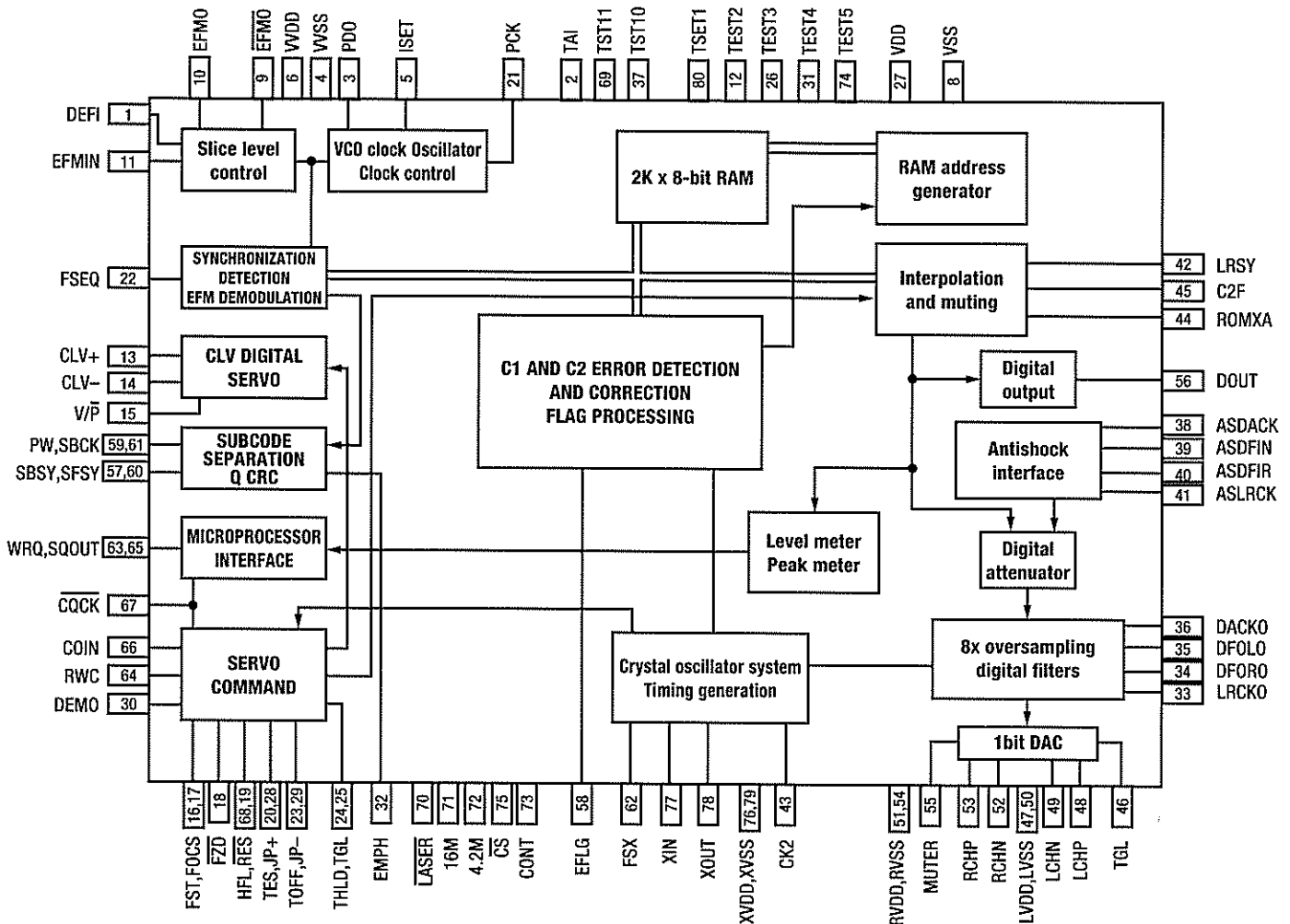

U302: PCM1710U

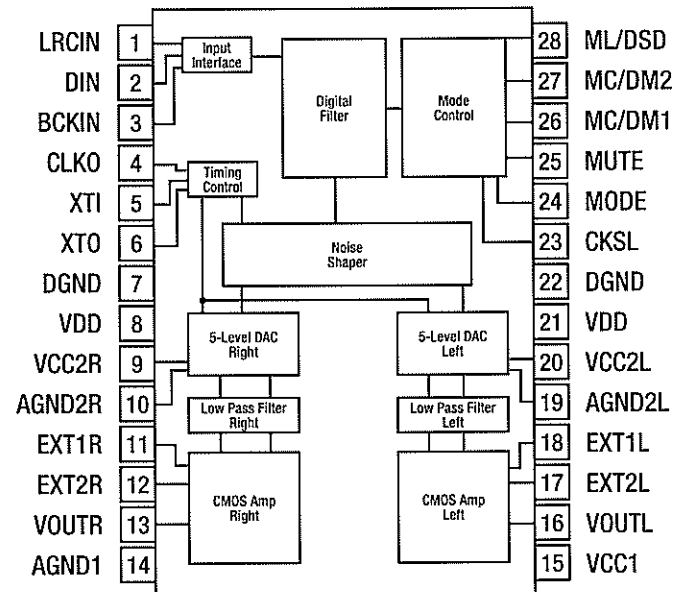

U403: TC74H00

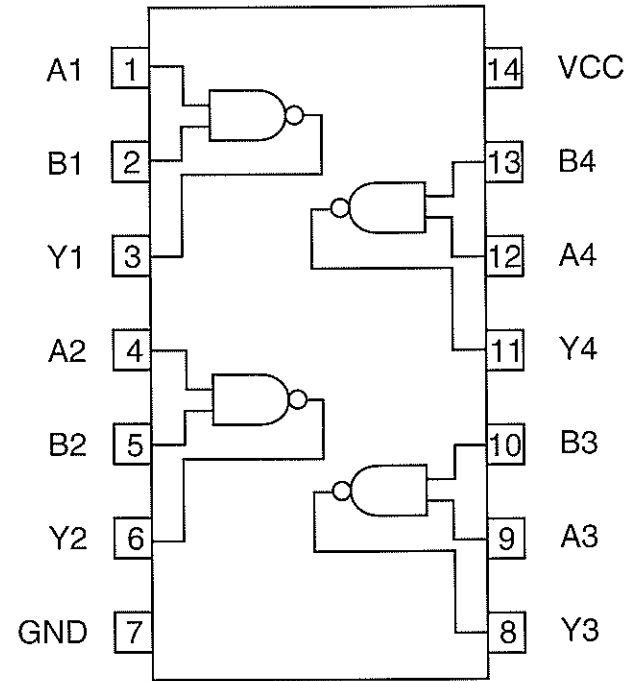

U201: LA6541D

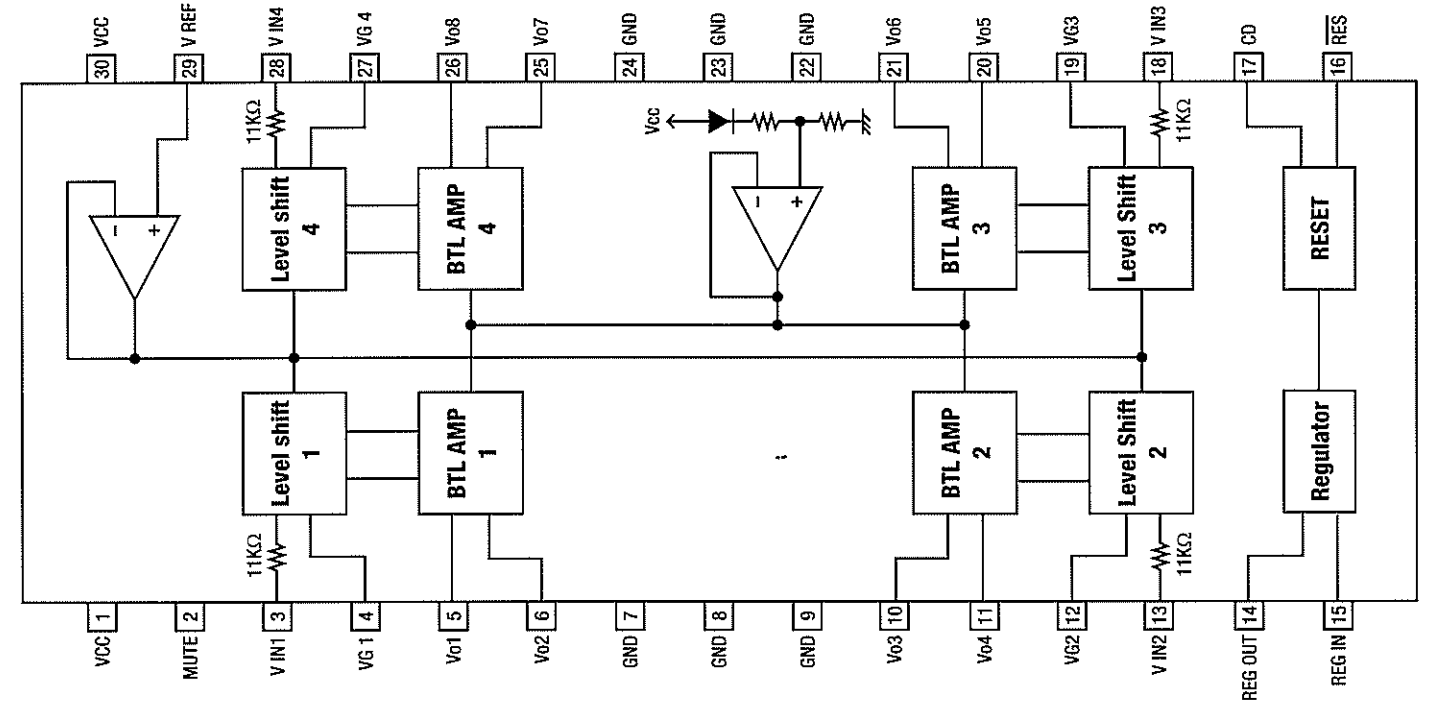

U701: LB1641

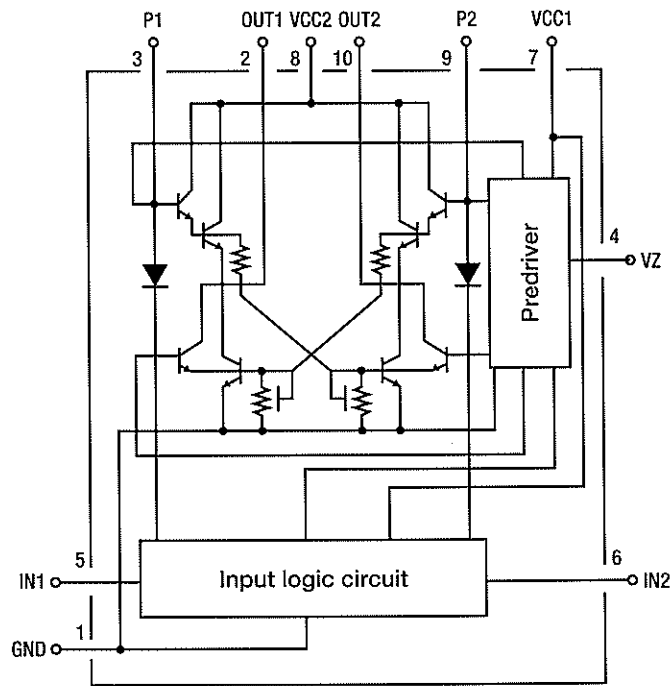

U305 - U306: NE5532

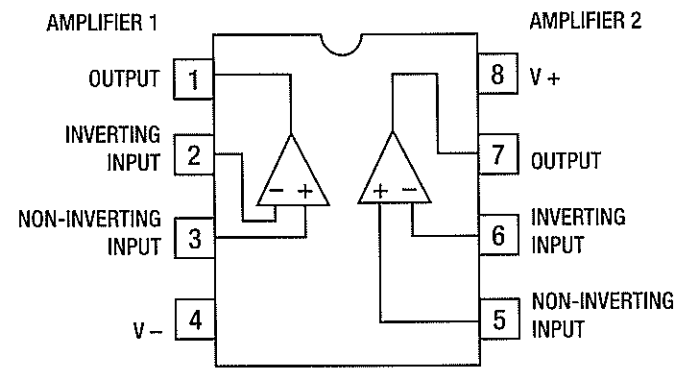

U401: LC587206A

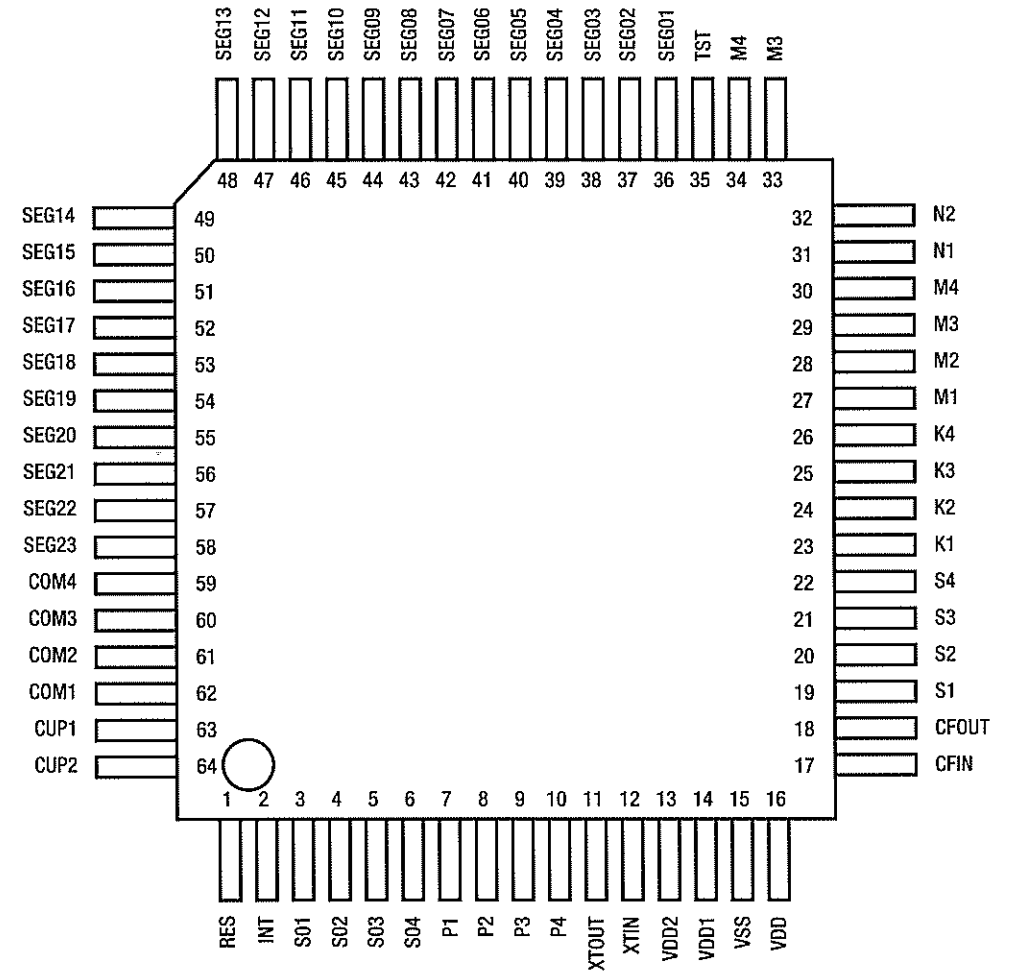

TROUBLESHOOTING GUIDE

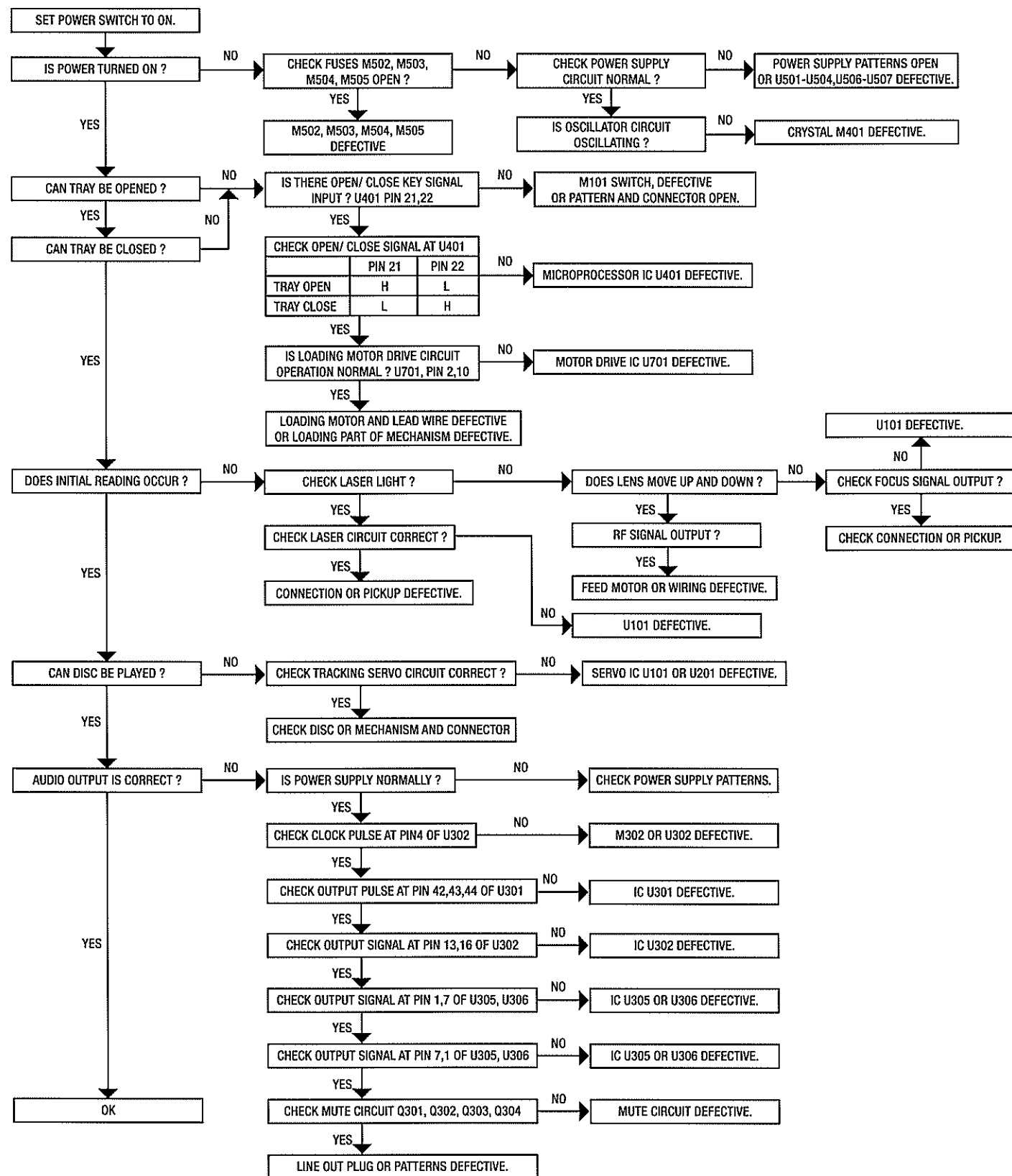

ELECTRICAL PARTS LIST

Reference No.	Part No.	Description
DISPLAY BOARD ASSEMBLY PCB BOARD		
	PCB-N0900C-DISP	DISPLAY ASSEMBLY
IR SENSOR		
M113	4816-043T-3	IR SENSOR PIC-26043TM2
LCD DISPLAY		
M501	2460-1340-1	LCD DISPLAY NEGATIVE
KEYBOARD ASSEMBLY PCB BOARD		
	PCB-N0900C-KEY	KEYBOARD ASSEMBLY
SWITCHES		
M101-M104	5200-3538-0	TACT SWITCH SKHHBY 7MM HIGH
M106,M108-M112	5200-3538-0	TACT SWITCH SKHHBY 7MM HIGH
LIVE BOARD ASSEMBLY PCB BOARD		
*AH	PCB-N0900C-LIVE	LIVE BOARD ASSEMBLY
*C	PCB-N0901C-LIVE	LIVE BOARD ASSEMBLY
CAPACITOR		
C800	8910-0049-0	CAP400V 4700P DE7150F472MVA1KC
JUMPERS		
J800*C	635N-0002-0	WJ ROLLER FORM D=0.6MM
J801*AH	635N-0002-0	WJ ROLLER FORM D=0.6MM
EMI FILTER		
M810*C	1806-2170-0	EMI FILTER TLN12UA
TRANSFORMER ASSEMBLY PCB BOARD		
*AH	PCB-N0900C-PWR	X'FORMER ASSEMBLY
*C	PCB-N0901C-PWR	X'FORMER ASSEMBLY
JUMPERS		
J401,J404*AH	635N-0002-0	WJ ROLLER FORM D=0.6MM
J403*C	635N-0002-0	WJ ROLLER FORM D=0.6MM
TRANSFORMER		
T1	1806-2194-0	EI-57 MAIN TRANSFORMER
MAIN BOARD ASSEMBLY PCB BOARD		
	PCB-N0900C-MAIN	MAIN BOARD ASSEMBLY
CAPACITORS		
C104	153F-333J-5-MS	CM 50V 0.033uF 5%
C106	153F-473J-5-NR	CM 50V 0.047uF 5%
C107	157F-104M-5-IU	CE 50V 0.1uF 20%
C109	153F-154J-5-NLM	CM 50V 0.15uF 5%
C114	153F-153K-5-KP	CM 50V 0.015uF 10%
C115	153F-183J-5-KP	CM 50V 0.018uF 5%

Reference No.	Part No.	Description
C118	157F-224M-5-IU	CE 50V 0.22uF 20%
C119	157E-475M-5-IU	CE 25V 4.7uF 20%
C120	157E-226K-5-IU	CE 25V 22uF 10%
C122	15CH-050D-5-GG	CC 50V 5pF +/-0.5pF NPO
C123	153F-222J-5-IM	CM 50V 2200pF 5%
C124	15CH-120J-5-GG	CC 50V 12pF 5% NPO
C125	153F-333J-5-MS	CM 50V 0.033uF 5%
C126	157F-106M-5-IU	CE 50V 10uF 20%
C127,C130	153F-103J-5-IM	CM 50V 0.01uF 5%
C128-C129	157B-107M-5-KM	CE 6.3V 100uF 20%
C131	153F-473J-5-NR	CM 50V 0.047uF 5%
C132	157F-334K-5-IU	CE 50V 0.33uF 10%
C134	157C-476M-5-IU	CE 10V 47uF 20%
C135	157B-227M-5-KW	CE 6.3V 220uF 20%
C137,C152	153F-103J-5-IM	CM 50V 0.01uF 5%
C138	157E-106M-5-IU	CE 25V 10uF 20%
C139	157B-107M-5-KM	CE 6.3V 100uF 20%
C141	157F-225M-5-IU	CE 50V 2.2uF 20%
C157	157C-477M-5-OW	CE 10V 470uF 20%
C202	157C-108M-5-S5	CE 10V 1000uF 20%
C204	157F-105M-5-IU	CE 50V 1uF 20%
C205	153F-103J-5-IM	CM 50V 0.01uF 5%
C304,C308	157B-107M-5-KM	CE 6.3V 100uF 20%
C320-C321,C323-C325	157B-106M-5-EI	CE 6.3V 10uF 20%
C326-C327	153F-103J-5-IM	CM 50V 0.01uF 5%
C328-C329	15CH-200J-5-GG	CC 50V 20pF 5% NPO
C332,C334	157B-106M-5-EI	CE 6.3V 10uF 20%
C356-C357	153F-272J-5-JM	CM 50V 2700pF 5%
C362-C363	153F-472J-5-KM	CM 50V 4700pF 5%
C366-C367	158F-681J-5-KW	CP 50V 680pF 5%
C368-C369	157E-226K-5-IU	CE 25V 22uF 10%
C370	153F-103J-5-IM	CM 50V 0.01uF 5%
C371-C374	157D-477M-5-OY	CE 16V 470uF 20%
C375-C376	157E-226M-5-IU	CE 25V 22uF 20%
C377-C379,C382	153F-224J-5-MIB	CM 50V 0.22uF 5%
C383	157C-226M-5-IU	CE 10V 22uF 20%
C402	157B-107M-5-KM	CE 6.3V 100uF 20%
C407	157D-108M-5-S9	CE 16V 1000uF 20%
C408	157E-226M-5-IU	CE 25V 22uF 20%
C410	157B-106M-5-EI	CE 6.3V 10uF 20%
C411	153F-103J-5-IM	CM 50V 0.01uF 5%
C418	157E-106M-5-IU	CE 25V 10uF 20%
C506-C507	157E-228M-5-X9	CE 25V 2200uF 20%
C508	157C-108M-5-S5	CE 10V 1000uF 20%
C511	157C-227M-5-KW	CE 10V 220uF 20%
C512-C513	157D-108M-5-S9	CE 16V 1000uF 20%
C518	157E-107M-5-KW	CE 25V 100uF 20%
C522	157D-107M-5-IU	CE 16V 100uF 20%
C523	157F-225M-5-IU	CE 50V 2.2uF 20%
C524	153F-223J-5-LQ	CM 50V 0.022uF 5%
C525	157D-477M-5-OY	CE 16V 470uF 20%
C527	157C-108M-5-S5	CE 10V 1000uF 20%
C529	157D-338M-5-W@	CE 16V 3300uF 20%
C533	157C-477M-5-OW	CE 10V 470uF 20%
C701,C704	153F-103J-5-IM	CM 50V 0.01uF 5%
C702	157C-476M-5-IU	CE 10V 47uF 20%
C710	157B-107M-5-KM	CE 6.3V 100uF 20%
DIODES		
D101,D401-D402	4804-1480-2	DIODE 1N4148 AT
D403	4837-3V31-2	ZD 1/2W 3.1-3.5V AT

Reference No.	Part No.	Description
D409,D411	4804-1480-2	DIODE 1N4148 AT
D501-D504	4804-0010-2	DIODE 1N4001AT
D505	4840-1140-0	ZD 1.3W 3.3V 5% AT
D506, D514-D517	4804-0010-2	DIODE 1N4001 AT
D707	4804-1480-2	DIODE 1N4148 AT
COIL		
J510, L101	1801-100K-M	COIL 10uH 10% BL7.0
L301	1802-0450-0	DIGITAL COIL 015-910-27BB
CRYSTAL & FILTER		
M302	2300-0110-0	CRYSTAL 16.9344 MHZ
M303	2704-0060-0	EMC FILTER DSS31055B271M
M401	2703-0150-0	CR4.00MHZ,CST4.00MGW
JACKS		
M317	2113-1300-0	2P RCA JACK W/R AU W/SHIELD
M318	2113-1170-0	1P RCA JACK YL AU HTJ-032-09
FUSES		
M502-M504*AH Δ	5120-0020-0	FUSE 1A 250V TIME LAG UL/CSA 5X20MM
M505*AH Δ	5120-0052-0	FUSE 1.6A 250V TIME LAG UL/CSA 5X20MM
M502-M504*C Δ	5120-0018-0	FUSE 1A 250V TIME LAG SEMKO/VDE 5X20MM
M505*C Δ	5120-0050-0	FUSE 1.6A 250V TIME LAG SEMKO/VDE 5X20MM
TRANSISTORS		
Q101	4851-015Y-5	TR 2SA1015-Y HFE120-240
Q301-Q304	4860-1780-5	TR 2SD655F HFE600-1200
Q305	485A-1346-5	TR 2SA1346 HFE 50-100
Q401,Q403	4860-0660-5	TR 2SA1015 GR
Q402	4851-012F-5	TR 2SD1012F/G HFE 160-560
Q520	4860-0050-5	TR KTC8050 C/D
RESISTORS		
R355-R356	4715-3571-2-K	RMF 3.57K 1/4W 1% AT
R390-R393	4717-221J-L	RMF 220R 1/2W 5% AF
R709	4756-4716-3-06	SVR 470 H3 7X7.6 RH0615C
ICS		
U101	3130-6710-0	IC LA9240 ASP FOR CD QIP64E
U201	3130-6720-0	IC LA6541D 4-CH BTL DRIVER DIP30SLF
U301	3130-6700-0	IC LC78621ED DSP FOR CD QIP80E
U302	3130-5660-0	IC PCM1710U D/A CONVERTER
U305-U306	3130-2430-0	IC-NE5532 OPER. AMP
U401	3130-6750-0	IC LC587206A MICRO-CONTROLLER
U403	3130-4160-0	IC TC74HC00AP DIGITAL
U501,U506	3130-2020-3	IC 7805 5V 1.5A REGULATOR
U502	3130-2520-3	IC 7812 12V REGULATOR
U503	3130-3800-0	IC UPC79M12HF REGULATOR
U504	3130-9030-0	IC NJM78L09A 9V 0.1A REGULATOR TO-92
U507	3130-2790-1	IC NJM7808FA +8V REGULATOR
U701	3130-6560-0	IC LB1641 MOTOR DRIVER
TRANSFORMER		
M501*	1806-2320-0	EL BACKLIGHT TRANSFORMER

- NOTE :
- The components identified by Δ mark are critical for risk of fire and electrical shock. Replace only with part number specified.
 - <*AH > : USA, Canadian model only.
 - <*C > : European model only.
 - Capacitors : CP-Polystyrene, CM-Mylar, CE-Electrolytic, CC-Ceramic.
 - Resistors : RMF-Metal Film.

MECHANISM EXPLODED VIEW

CD93F8

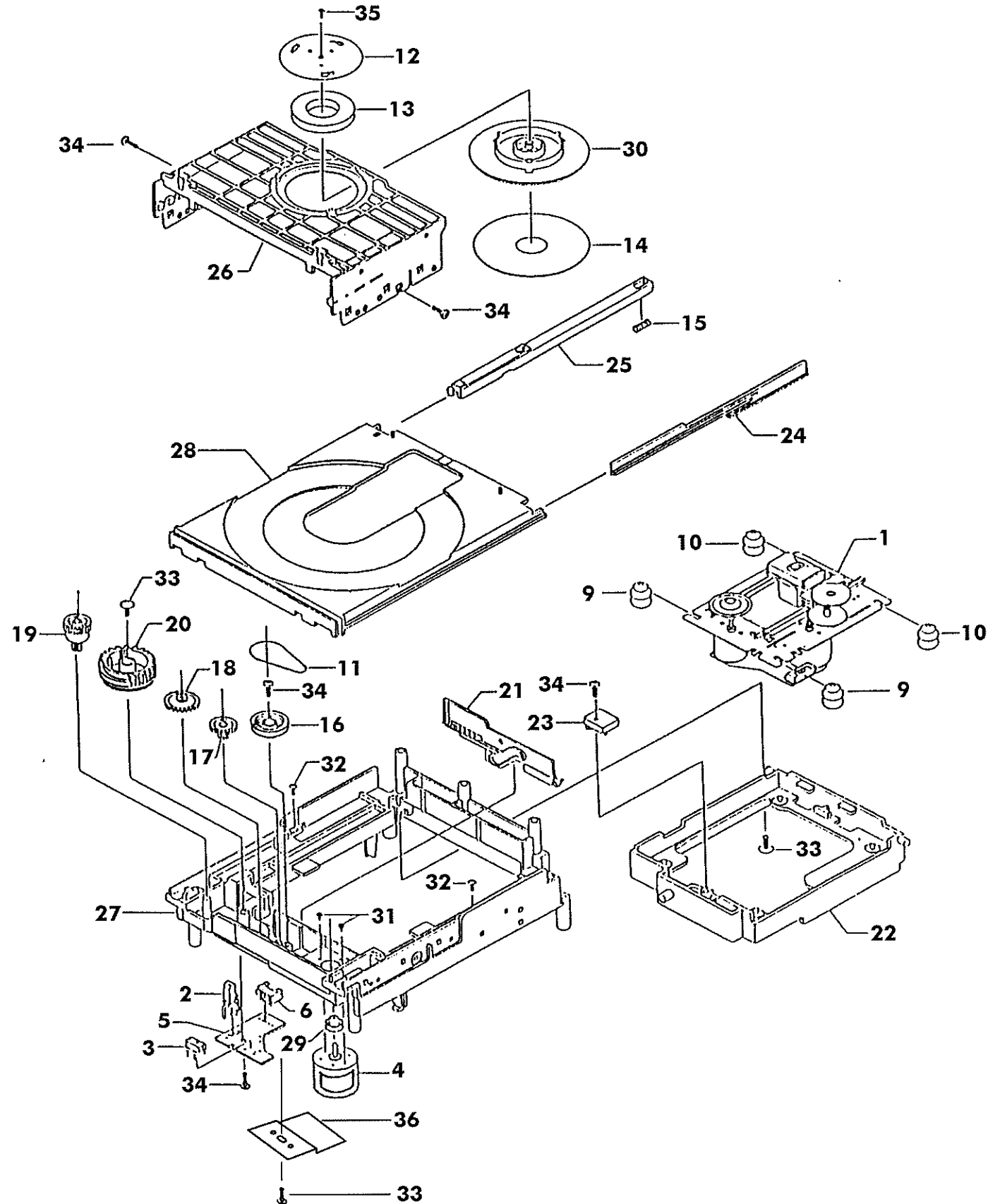

EXPLODED VIEW PARTS LIST OF MECHANISM CD93F8

Item	Part No	Description	Qty
1	4102-5002-0	CD94V5 MECHANISM	1
2	4102-5003-0	SWITCH LEAF	1
3	4102-5004-0	SWITCH PUSH 2-1	1
4	4102-5005-0	LOADING MOTOR	1
5	4102-5006-0	CON/SW PCB	1
6	4102-5007-0	CON JST 5P RT	1
9	4102-5008-0	Hardness 60° CUSHION RUBBER	2
10	4102-5009-0	Hardness 50° CUSHION RUBBER	2
11	4102-5010-0	BELT SQUARE	1
12	4102-5011-0	PLATE MAGNET	1
13	4102-5012-0	MAGNET DISK	1
14	4102-5013-0	SHEET	1
15	4102-5014-0	SPRING RAIL	1
16	4102-5015-0	PULLEY GEAR	1
17	4102-5016-0	GEAR IDLER A	1
18	4102-5017-0	GEAR IDLER B	1
19	4102-5018-0	GEAR TRAY	1
20	4102-5019-0	GEAR MEDIATION	1
21	4102-5020-0	SLIDER	1
22	4102-5021-0	CDM MOUNTING BASE	1
23	4102-5022-0	FIXITY	1
24	4102-5023-0	RAIL RIGHT	1
25	4102-5024-0	RAIL LEFT	1
26	4102-5025-0	SUPPORT MAGNET	1
27	4102-5026-0	BASE FRAME	1
28	4102-5027-0	CD TRAY	1
29	4102-5028-0	PULLEY MOTOR	1
30	4102-5029-0	HOLDER MAGNET	1
31	4102-5030-0	SCREW PAN+SW 1.7x3.5	2
32	4102-5031-0	SCREW S-TPG PAN+FLG 2x6	2
33	4102-5032-0	SCREW S-TPG BRZ+FLG 3x8	3
34	4102-5033-0	SCREW S-TPG BIN 2.6x7.8	5
35	4102-5034-0	SCREW SPECIAL 1.7x4.0	1
36	4102-5035-0	BRACKET	1

EXPLODED VIEW

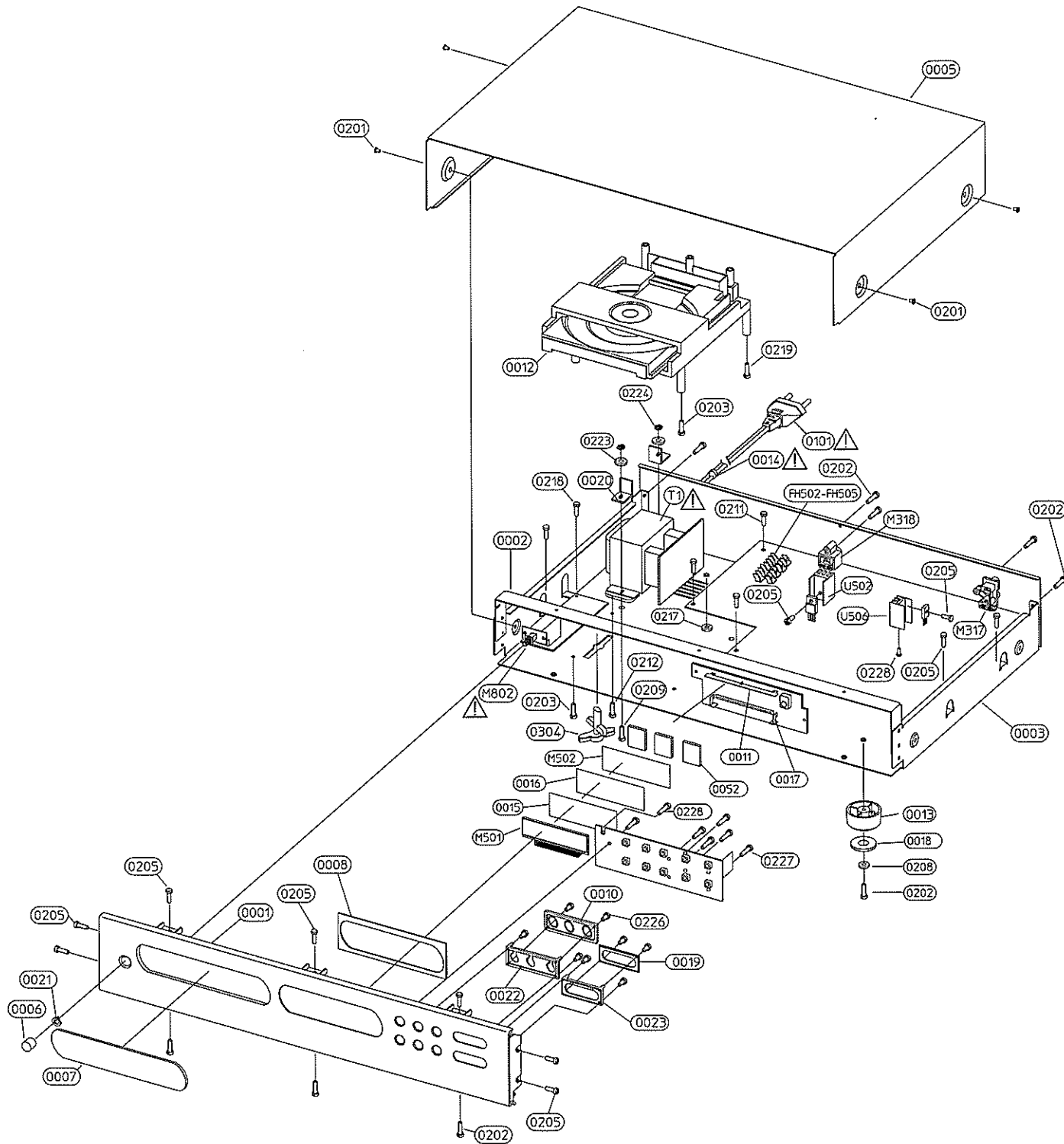

EXPLODED VIEW PARTS LIST

Item	Part No	Description	Qty
0001	1465-5701-0	FASCIA W/SS PAINT	1
0002	1402-3781-1	STRAP	1
0003*AH	1402-3511-0	CHASSIS W/SS PAINT	1
0003*C	1402-3513-0	CHASSIS W/SS PAINT	1
0005	1402-3530-0	COVER	1
0006	2442-1000-0	POWER BUTTON	1
0007	1464-6011-2	CD DOOR W/PAINT	1
0008	3716-4311-0	WINDOW LENS W/SS	1
0010	2444-1201-0	BUTTON TRIO	2
0011	4134-3011-0	LCD/EL HOLDER	1
0012	4111-0901-1	CD DECK	1
0013	4152-4631-0	RUBBER FOOT 14MM HIGH	4
0014	4151-9461-0	STRAIN RELIEF BUSHING 4N-4	1
0015	3716-3505-0	PC SHEET FILTER	1
0016	3716-3502-0	POLYESTER SHEET LEE FILTER PN253	1
0017	4134-3041-0	LCD CORNER BRACKET	2
0018	4152-4641-0	CUSHION FOOT	4
0019	2444-1301-0	BUTTON RACKER	2
0020	4132-6191-0	X'FORMER MOUNTING BRACKET	2
0021	4152-4331-0	POWER BUTTON BEZEL	1
0022	4154-0031-0	BEZEL TRIO	2
0023	4154-0091-0	BEZEL RACKER	2
0052	4152-4841-1	BLACK CUSHION	3
0101*AH	7009-3100-2	AC CORD 18AWGX2 SPT-2 D.INSULATED UL/CSA	1
0101*C	7009-3110-0	AC CORD SEMKO	1
0201	2900-4006-3010	M4X0.5PX6MM W/FLAT WASHER	4
0202	2954-3008-3000	TAPPING SCREW 3X8MM (BLK.ZN)	12
0203	2954-3010-3000	TAPPING SCREW 3X10MM (BLK.ZN)	2
0205	2954-3008-0000	TAPPING SCREW 3X8MM (YEL.ZN)	14
0208	2842-3367-0	METAL WASHER ID=3.3 OD=6.7	4
0209	2900-4010-3030	PH W/WASHER M4X10 (BLK.ZN)	2
0211	2904-3006-0000	SCREW 3X6MM (YEL.ZN)	4
0212	2954-3510-3000	TAPPING SCREW 3.5X10MM (BLK.ZN)	1
0217	2842-3367-0	METAL WASHER ID=3.3 OD=6.7	1
0218	2954-3006-0000	TAPPING SCREW 3X6MM (YEL.ZN)	2
0219	2954-4010-3000	SCREW TAP-C2 BH M4X 10 M M BZ CROSS	1
0223	2600-4008-0973	FLAT WASHER M4X0.8X9.7 BZ	2
0224	2640-4030-0703	M4 NUT (BLK)	2
0226	2954-2006-0000	TAPPING SCREW 2X6MM (YEL.ZN)	8
0227	2954-2608-0000	TAPPING SCREW 2.6X8MM (YEL.ZN)	7
0228	2950-2608-3000	TAPPING SCREW 2.6X8MM PH (BLK.ZN)	3
0304	1463-160B-0	CD TRANSIT LOCK	1
FH502-FH505	4131-9131-0	FUSE HOLDER 6.5MM PITCH RECT	8
M317	2113-1300-0	2P RCA JACK W/R AU W/SHIELD	1
M318	2113-1170-0	1P RCA JACK YL AU HTJ-032-09	1
M501	2460-1340-1	LCD DISPLAY NEGATIVE	1
M502	2450-1146-0	EL BACKLIGHT	1
M802	5200-3151-0-01	POWER SWITCH	1
T1	1806-2194-0	EI-57 MAIN TRANSFORMER	1
U502	5400-0831-0	HEAT SINK 20MM-HIGH HOLE	1
U506	5400-9130-0	HEAT SINK	1

NOTE : - The components identified by Δ mark are critical for risk of fire and electrical shock. Replace only with part number specified.
 - <*AH> : USA, Canadian model only.
 - <*C> : European model only.

PACKING DIAGRAM

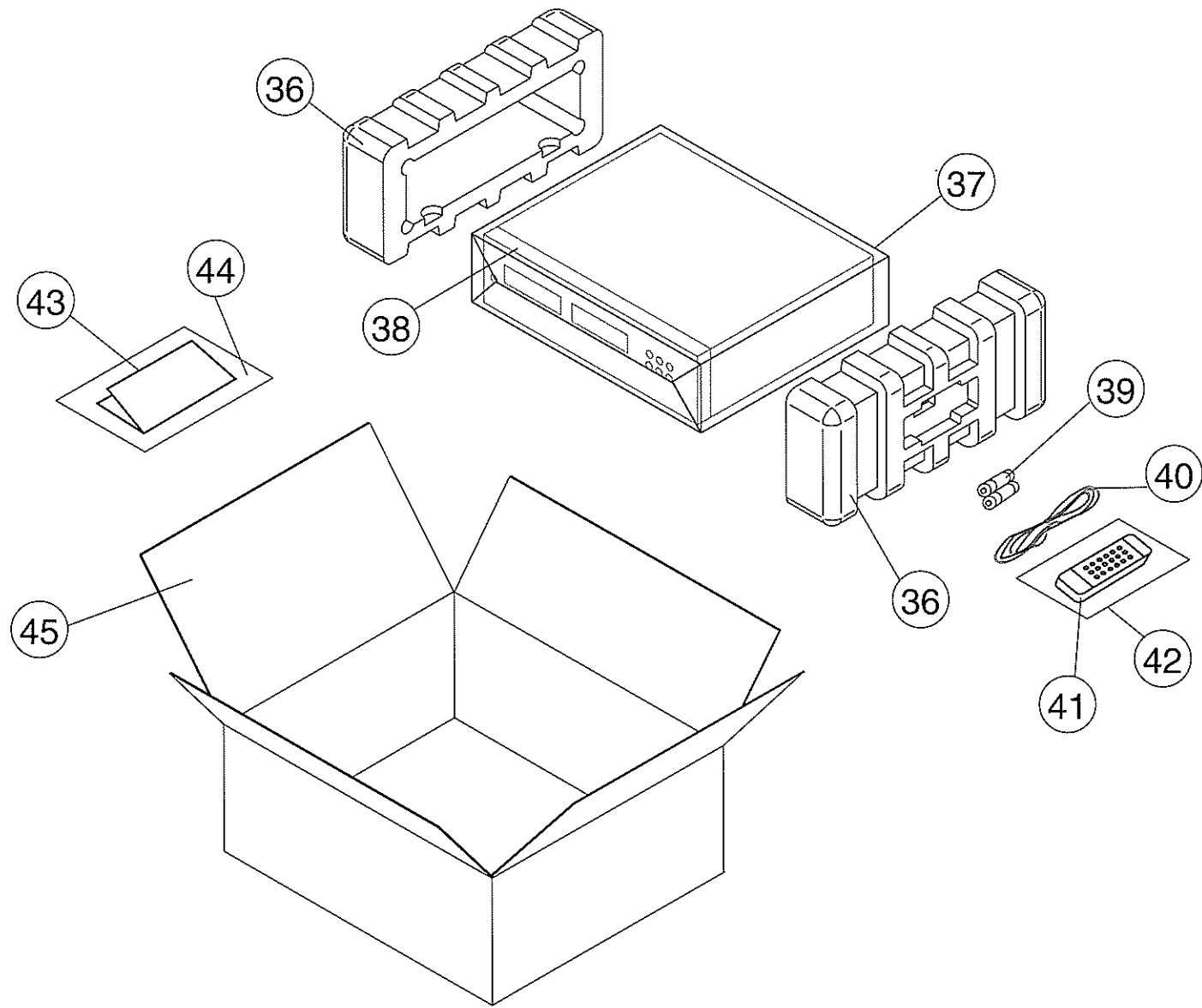

ITEM	PART NO.	DESCRIPTION	Q'TY
36	1490-1783-0	POLYFOAM ENDCAP	2
37	1497-1332-1	UNIT POLYBAG	1
38	1497-1432-0	FASCIA COVER	1
39	4060-0530-0	BATTERIES	2
40	2103-7302-1	RCA CABLE	1
41	8900-9180-0	REMOTE CONTROL HANDSET	1
42	1497-1302-1	REMOTE CONTROL POLYBAG	1
43	4301-4836-0	INSTRUCTION MANUAL	1
44	1497-1062-0	MANUAL POLYBAG	1
45	1480-0201-1	CARTON BOX	1

Proprietary information for servicing purposes only. The information herein may not be used commercially without the prior written agreement of NAD Electronics Ltd., London, England.