

SERVICE MANUAL

NAD

C 525BEE

**COMPACT
DISC PLAYER**

C 525BEE

**COMPACT
DISC PLAYER**

SAFETY INFORMATION

CAUTION

CAUTION - INVISIBLE LASER RADIATION WHEN OPEN AND INTERLOCKS DEFEATED. AVOID EXPOSURE TO BEAM.

ADVARSEL - USYNLIG LASERSTRÅLING NÅR DEKSEL ÅPNES OG SIKKERHEDSLÅS BRYTES. UNNGÅ EKSPONERING FOR STRÅLEN.

ADVARSEL - USYNLIG LASERSTRÅLING VED ÅBNING, NÅR SIKKERHEDSAFBRYDERE ER UDE AF FUNKTION. UNDGÅ UDSÆTTELSE FOR STRÅLING.

VARNING - OSYNLIG LASERSTRÅLNING NÅR DENNA DEL ÄR ÖPPNAD OCH SPÄRRAR ÄR URKOPPLADE. STRÅLEN ÄR FARLIG.

VARO! - AVATTAESSA JA SUOJALUKITUS OHITETTAESSA OLET ALTIINA NÄKTMÄTÖNTÄ LASERSÄTEILYLLE. ÄLÄ KAISO SÄTEESEEN.

VORSICHT! - UNSICHTBARE LASERSTRAHLUNG TRITTT AUS, WENN DECKEL GEÖFFNET UND WENN SICHERHEITVERRIEGELUNG ÜBERBRÜCKT IST. NICHT DEM STRAHL AUSSETZEN.

**CLASS 1
LASER PRODUCT**

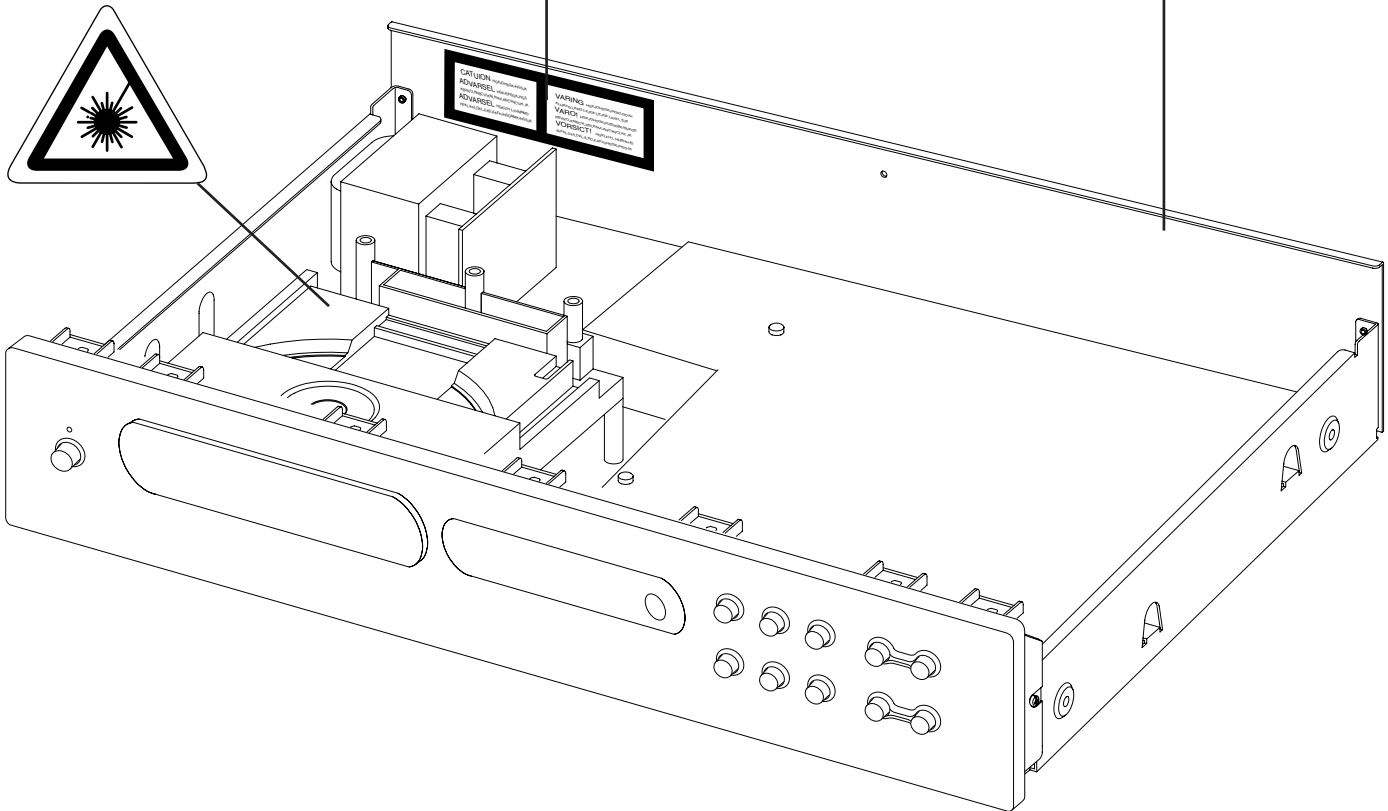

The lightning flash with arrowhead, within an equilateral triangle is intended to alert the user of the presence of uninsulated "dangerous voltage" within the product's enclosure; that may be of sufficient magnitude to constitute a risk of electric shock to persons.



The exclamation point within an equilateral triangle is intended to alert the user of the presence of important operating and maintenance (servicing) instructions in the literature accompanying the appliance.

THIS DEVICE COMPLIES WITH PART 15 OF THE FCC RULES. OPERATION IS SUBJECT TO THE FOLLOWING TWO CONDITIONS:-
(1) THIS DEVICE MAY NOT CAUSE HARMFUL INTERFERENCE, AND
(2) THIS DEVICE MUST ACCEPT ANY INTERFERENCE RECEIVED, INCLUDING INTERFERENCE THAT MAY CAUSE UNDESIRED OPERATION.

SERVICE SAFETY PRECAUTIONS

1. Replacing the fuses

CAUTION: FOR CONTINUED PROTECTION AGAINST THE RISK OF FIRE REPLACE ONLY WITH SAME TYPE OF FUSE.

Reference No		Part Number	Description
M502-M504	*CA \triangle	5120-0020+0	FU T1A 250V UL/CSA 5x20MM
M502-M504	*EU \triangle	5120-0018+0	FU T1A 250V SEMKO/UDE 5x20MM
M505	*CA \triangle	5120-0052+0	FUSE T1.6A 250V 5x20MM UL/CSA
M505	*EU \triangle	5120-0050+0	FUSE T1.6A 250V 5x20MM SEMKO/VDE

NOTE:

<*CA > : CANADIAN MODEL ONLY.

<*EU > : EUROPEAN MODEL ONLY.

2. Safety check out

(Only U.S.A. model)

Before returning the product to the customer, make leakage current or resistance measurements to determine that exposed parts are acceptably insulated from the supply circuit.

Parts marked with the symbol \triangle are critical with regard to the risk of fire and electric shock. Replace only with parts recommended by the manufacturer.

CONTENTS

DESCRIPTION	PAGE
SPECIFICATIONS	4
REAR PANEL / FRONT PANEL	5
DISASSEMBLY INSTRUCTIONS	6
BLOCK DIAGRAM	7
WIRING DIAGRAM	8
RF PATTERN TESTING	9
IMPORTANT NOTES	10-11
PCB LAYOUT	12-13
SCHEMATIC DIAGRAM	14-18
IC BLOCK DIAGRAM	19-22
TROUBLESHOOTING GUIDE	23
ELECTRICAL PARTS LIST	24-33
MECHANISM EXPLODED VIEW	34
MECHANISM EXPLODED VIEW PARTS LIST	35
EXPLODED VIEW	36
EXPLODED VIEW PARTS LIST	37-38
PACKING DIAGRAM	39

SPECIFICATIONS

Disc Capacity	One Disc, 120 or 80 mm
Decoding	BURR-BROWN Delta Sigma 20bit
Digital Filter	8 Times oversample
Analog Filter	4 pole active
Frequency Response	+/- 0.5 dB, 5Hz - 20kHz
De-Emphasis Error	+/- 0.3 dB
THD (at 0 dB, 1kHz)	0.003%
Intermodulation Distortion	< - 100 dB
(19 + 20 kHz)	
Dynamic Range	96 dB
Linearity	+/- 0.5 dB, 0 dB to -80 dB
Signal / Noise Ratio (A-Weight)	≥106 dB, De-Emphasis on ≥106 dB, De-Emphasis off
Channel Separation 1kHz	>90 dB
10 kHz	>80 dB
Wow and Flutter	Unmeasurable (Quartz Crystal Accuracy)
Output Impedance	200 Ω
Output Level at 0 dB	2.1 V rms
Digital Error Correction	IRC with double error correction in C1 and C2
Digital Code Output	Sony / Philips Serial data format
Power Consumption	12W

CONTROLS

Play / Pause, Stop, Random, Skip (< >), Scan (< >), Open, Time, Repeat.

PHYSICAL SPECIFICATIONS

Dimensions (Width x Height x Depth)	435 x 80 x 285 mm
Net weight	4 kg (8.8 lbs)
Shipping weight	5.1 kg (11.22 lbs)

REAR PANEL / FRONT PANEL

REAR PANEL

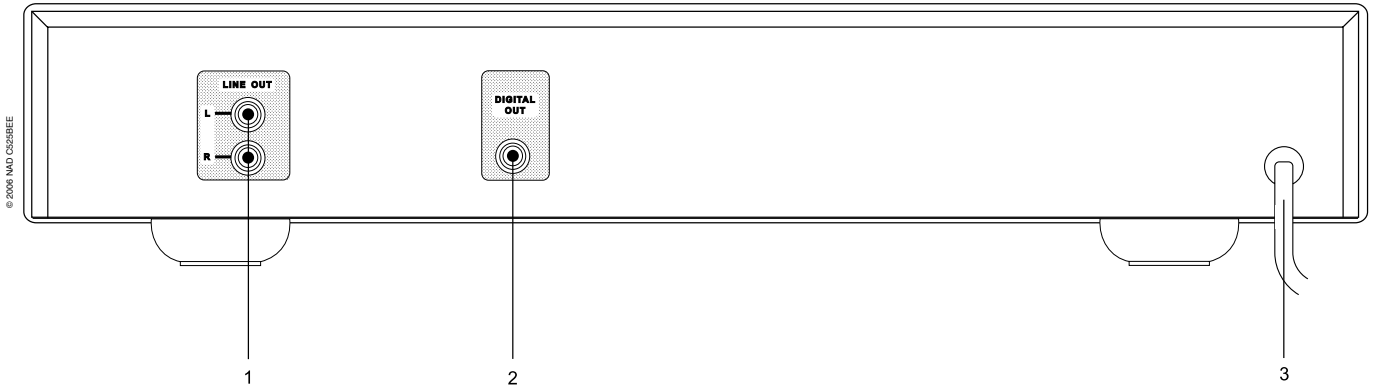

1. LINE OUT
2. DIGITAL OUT

3. AC LINE CORD

FRONT PANEL

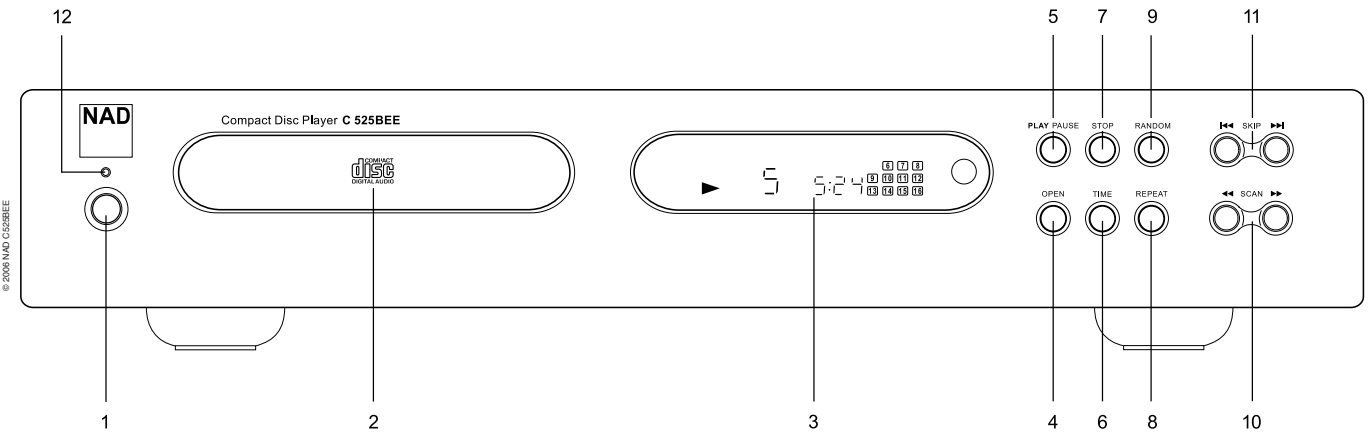

1. POWER ON / OFF
2. DISC DRAWER
3. DISPLAY
4. OPEN
5. PLAY / PAUSE
6. TIME

7. STOP
8. REPEAT
9. RANDOM
10. SCAN Back (◀◀) / Forward (▶▶)
11. SKIP Back (◀◀◀) / Forward (▶▶▶)
12. STANDBY LED

DISASSEMBLY INSTRUCTIONS

1. Remove machine screws M 4.0 x 6.0 (① to ④) from the side panels.
Remove tapping screw 3.0 x 8.5 (⑤) from the back panel.
Refer to **Figure No.1**.

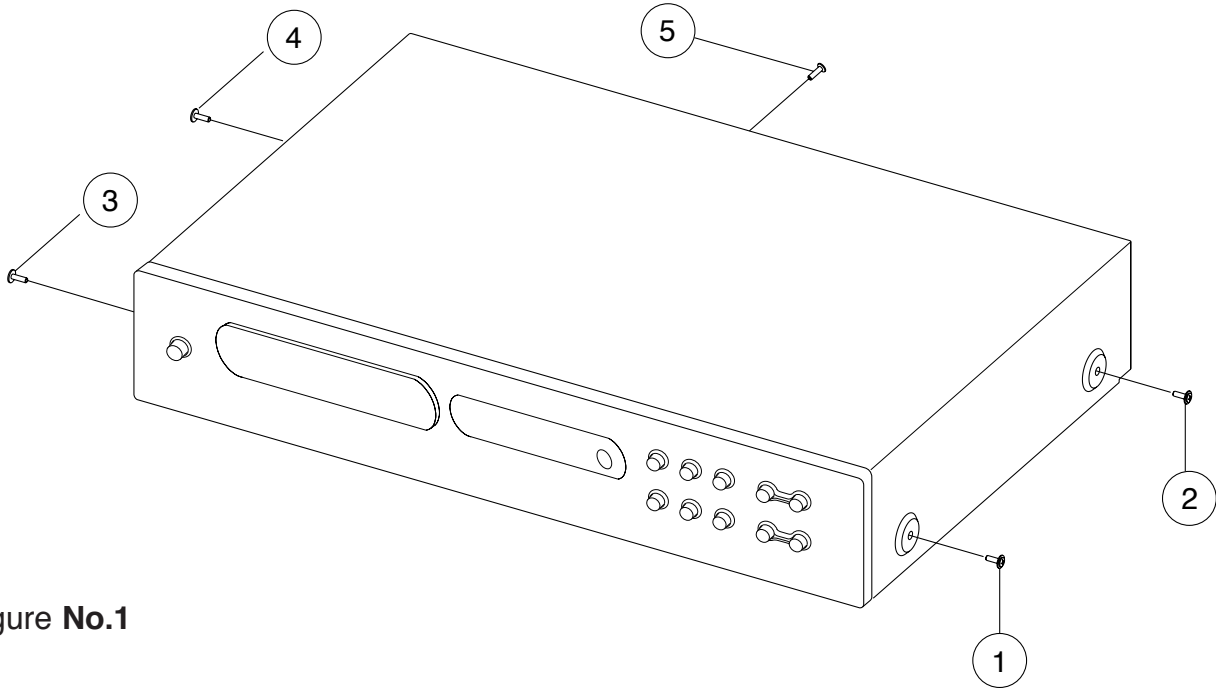

Figure No.1

2. Pull both sides of the TOP COVER slightly outwards (⑥) and tilt approx. 35° and then remove in the direction as indicated by the arrow (⑦). Refer to **Figure No.2**.

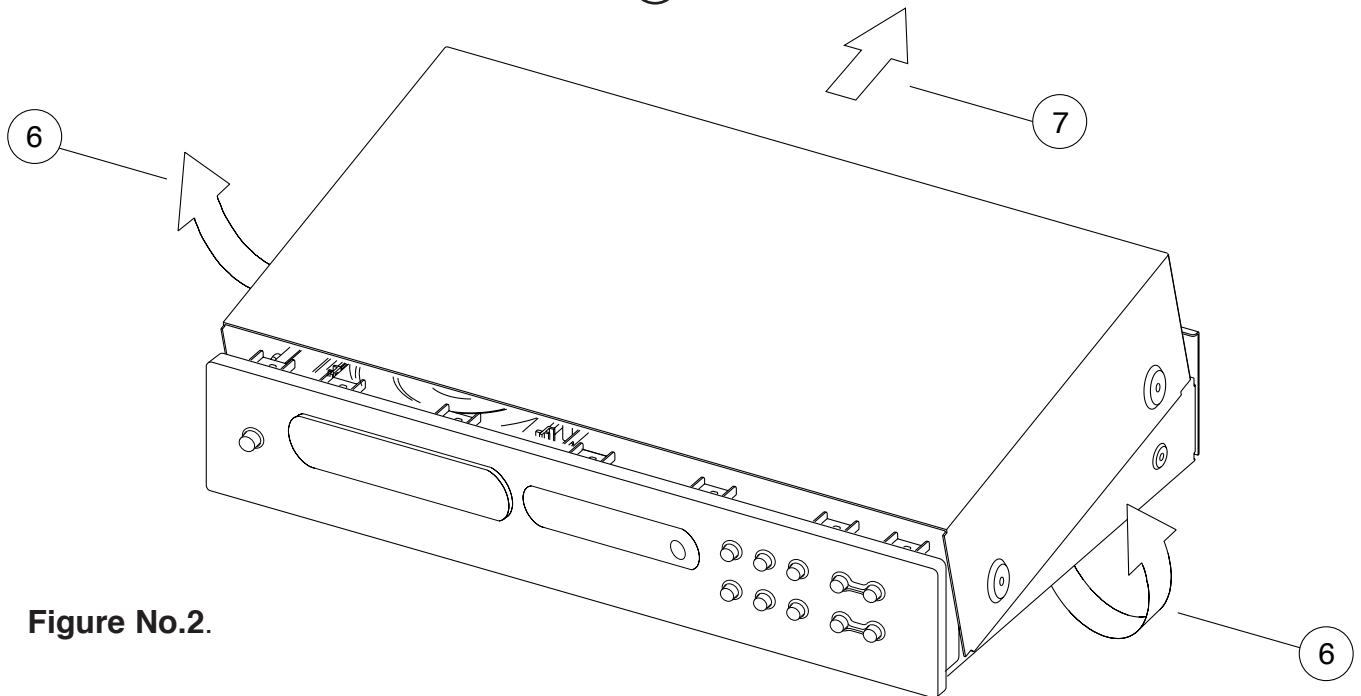
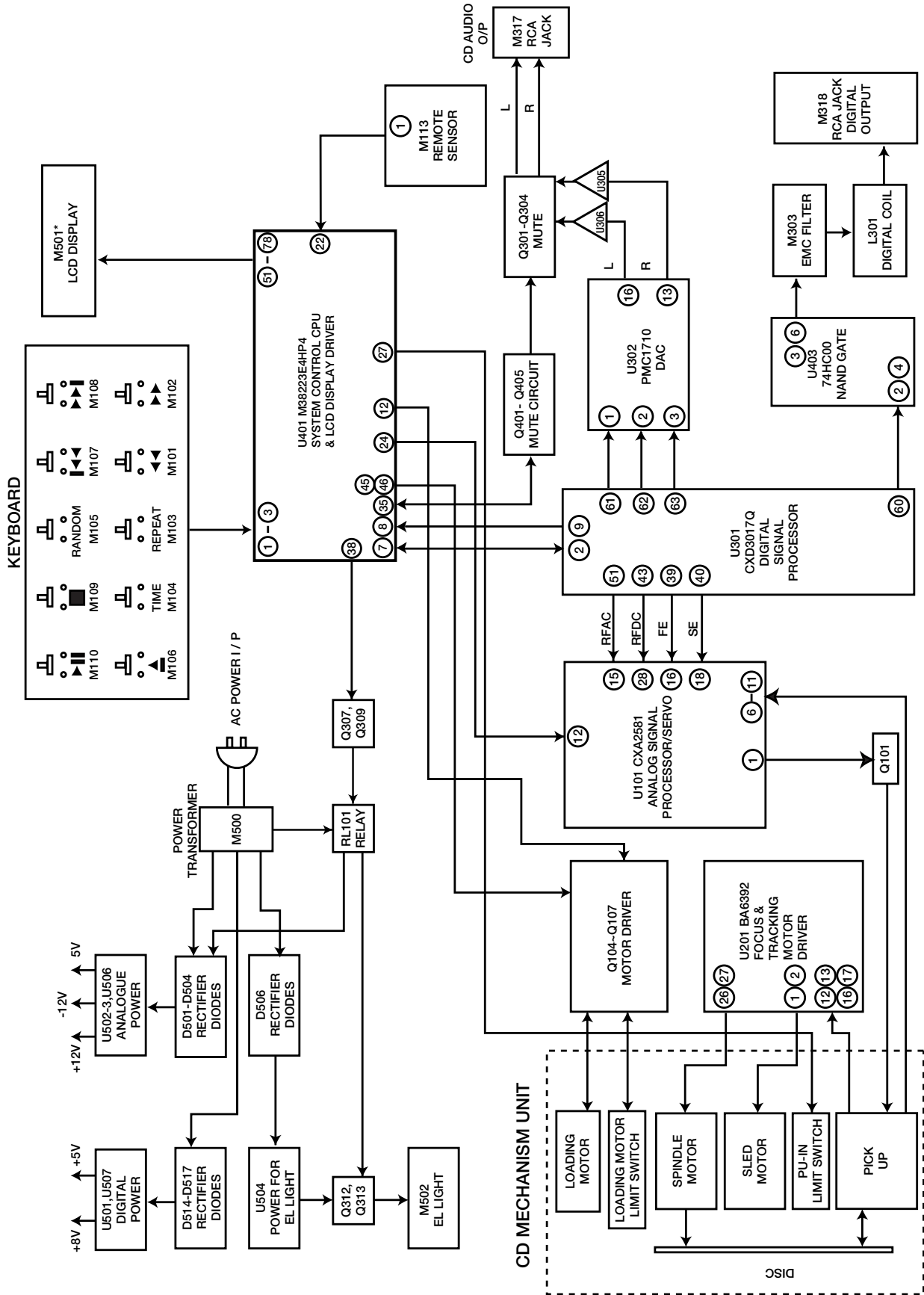
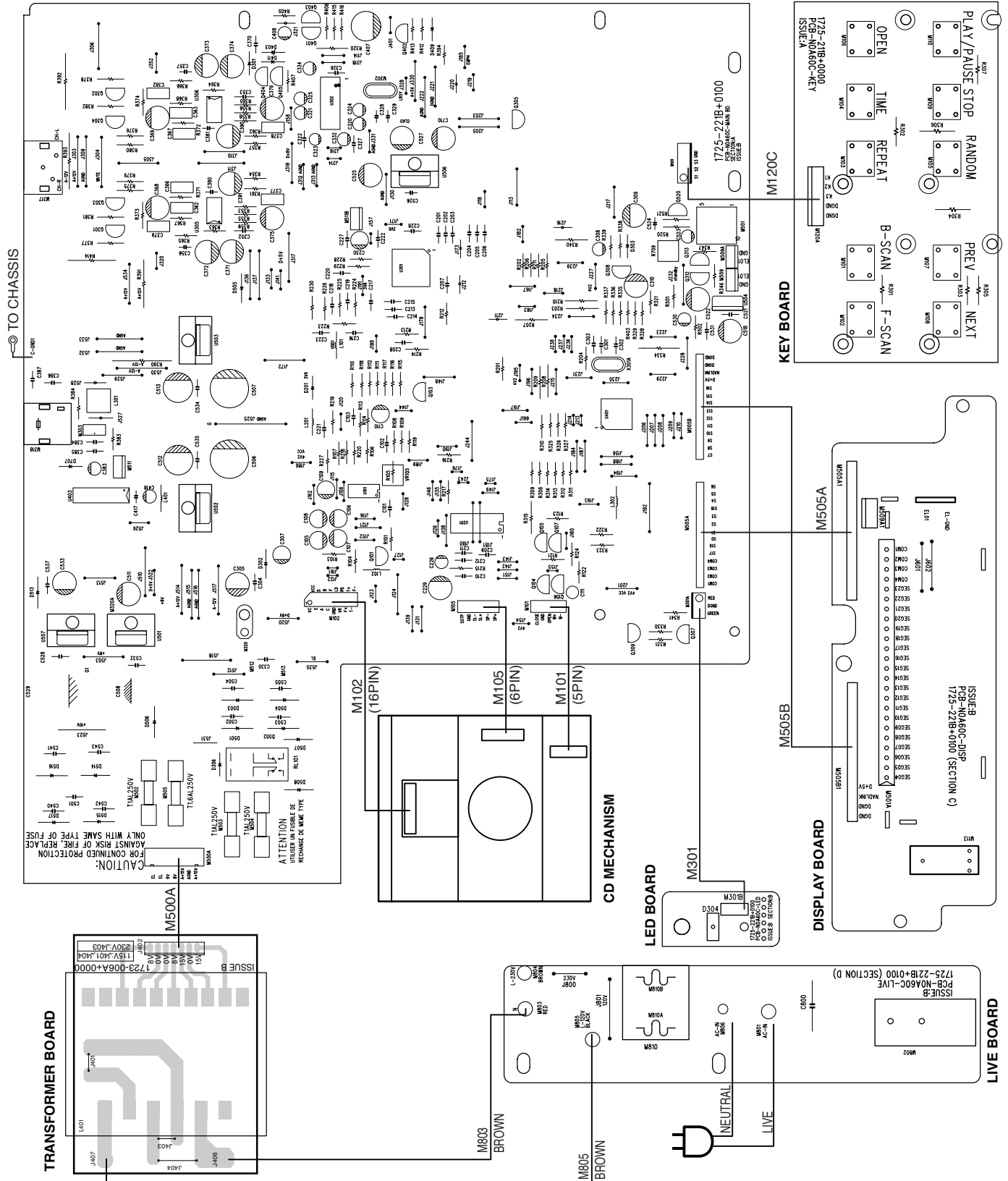

Figure No.2.

BLOCK DIAGRAM



WIRING DIAGRAM



IMPORTANT NOTES

INSTRUCTION FOR HANDLING OPTICAL SYSTEM BLOCK PICK-UP

Electrostatic breakdown of the laser diode in the optical system block may occur due to a potential difference caused by electrostatic charge accumulated on clothing, human body, etc. A ground must be provided as follows to prevent any electrostatic charge during unpacking or repair work.

1. Ground for Human Body

Be sure to wear a ground band (1M ohm) that is properly to remove any static electricity that may be charged on the body.

2. Ground for Work Bench

Be sure to place a conductive sheet (1M ohm) or copper plate with proper grounding on the work bench or other surface on which the pick-up is to be placed.

3. Because the static electricity charge on the clothing does not discharge through the body grounding band, do not let clothing to get in contact with the pick-up unit.

INCORRECT

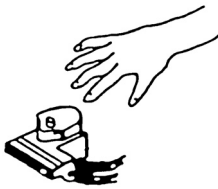

CORRECT

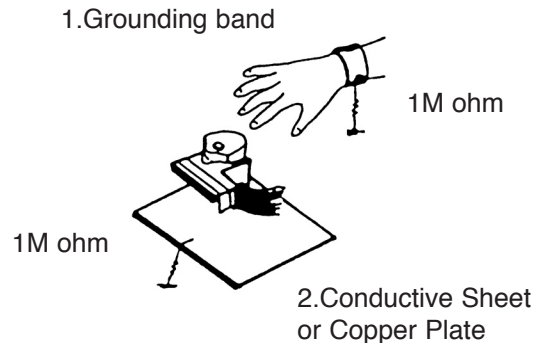

NOTE: Laser diodes are so susceptible to damage from static electricity that even if a static discharge does not ruin the diode, it can shorten its life or cause it to work improperly.

PRECAUTIONS FOR CHECKING BEAM EMISSION

The laser beam of this unit is focused on the reflecting surface of the objective lens in the optical system block. Therefore, keep your eyes at least 12 inches (30 cm) away from the objective lens when the laser diode is **ON**. (Operation Check Method for Laser Diode and Focus Search Function.)

When the **POWER** switch is turned **ON** after the chucking plate is removed, observe the objective lens and confirm that the following operations are performed properly.

(The optical system should be at the lead-in area position when it is checked at this time.)

- (1) The laser should be at the innermost position after the chucking plate is removed.
- (2) The diffused light of the laser beam can be seen when the **POWER** switch is turned **ON**.
- (3) Vertical (up and down) movement of the objective lens (2 or 3 times) will take place.

PRECAUTIONS WHEN CHANGING LASER PICK-UP

When removing the pick-up assembly, short circuit the PCB tracks on the optical block as show in the drawing in order to protect the pick-up before removal.

NOTE: Replacement pick-up assemblies are supplied with the PCB pattern already protected.

DO NOT REMOVE THE SHORT CIRCUITS UNTIL YOU HAVE FINISHED FITTING THE PICK-UP.

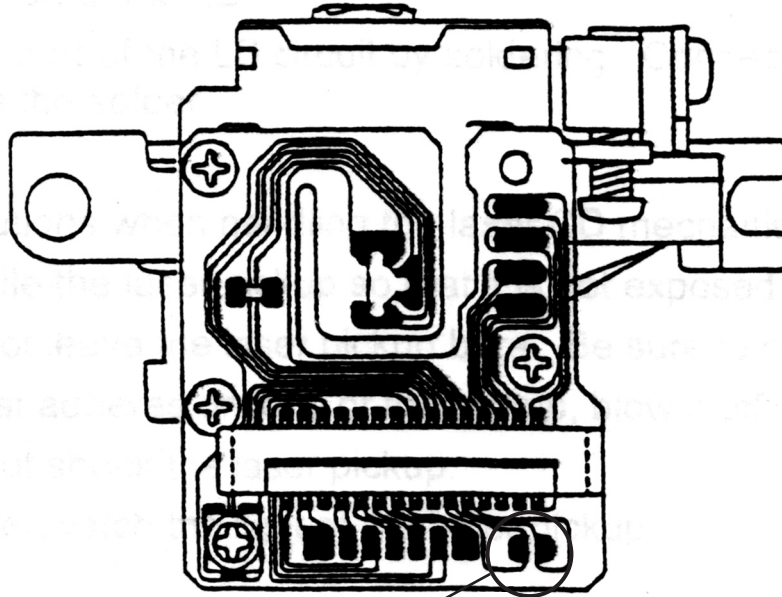

Protective soldering place
for laser diode

Caution:

Laser diodes are extremely susceptible to damage from static electricity. Even if a static discharge does not ruin the diode, it can shorten its life or cause it to work improperly. When replacing the pick-up, use a conductive mat, a grounded soldering iron, and so on, to protect the laser diode from static damage.

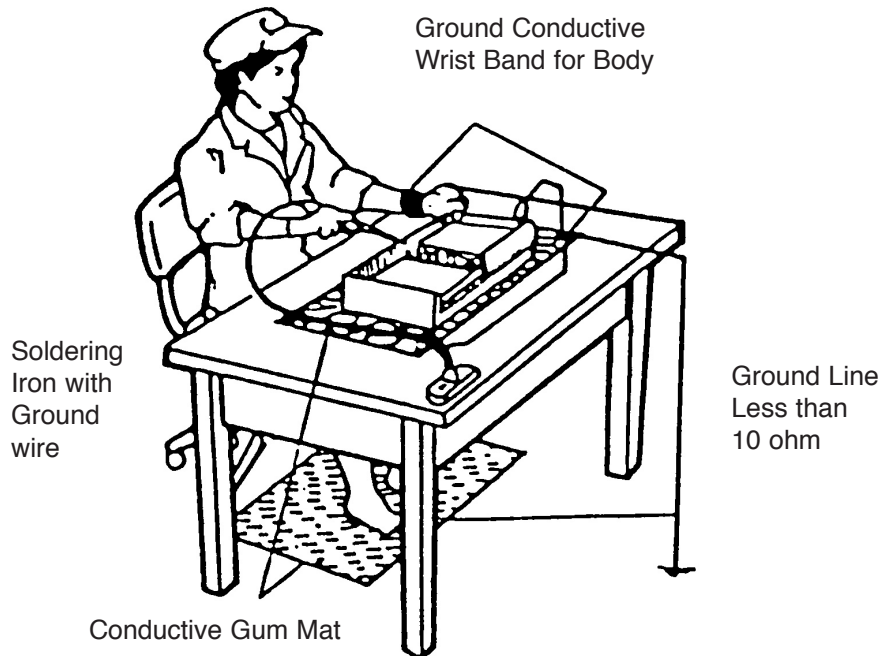

MAIN BOARD

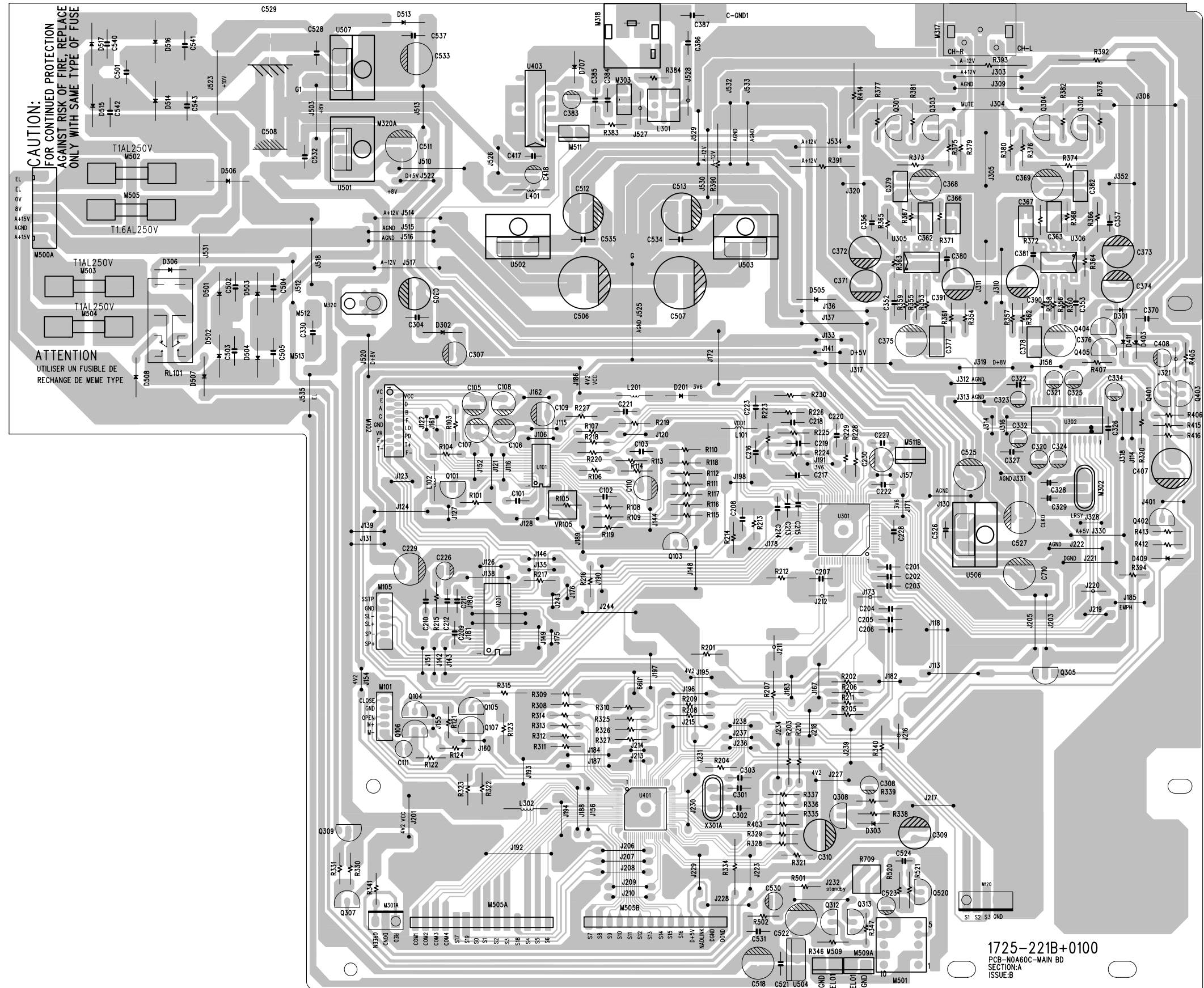

SCHEMATIC DIAGRAM

DISPLAY

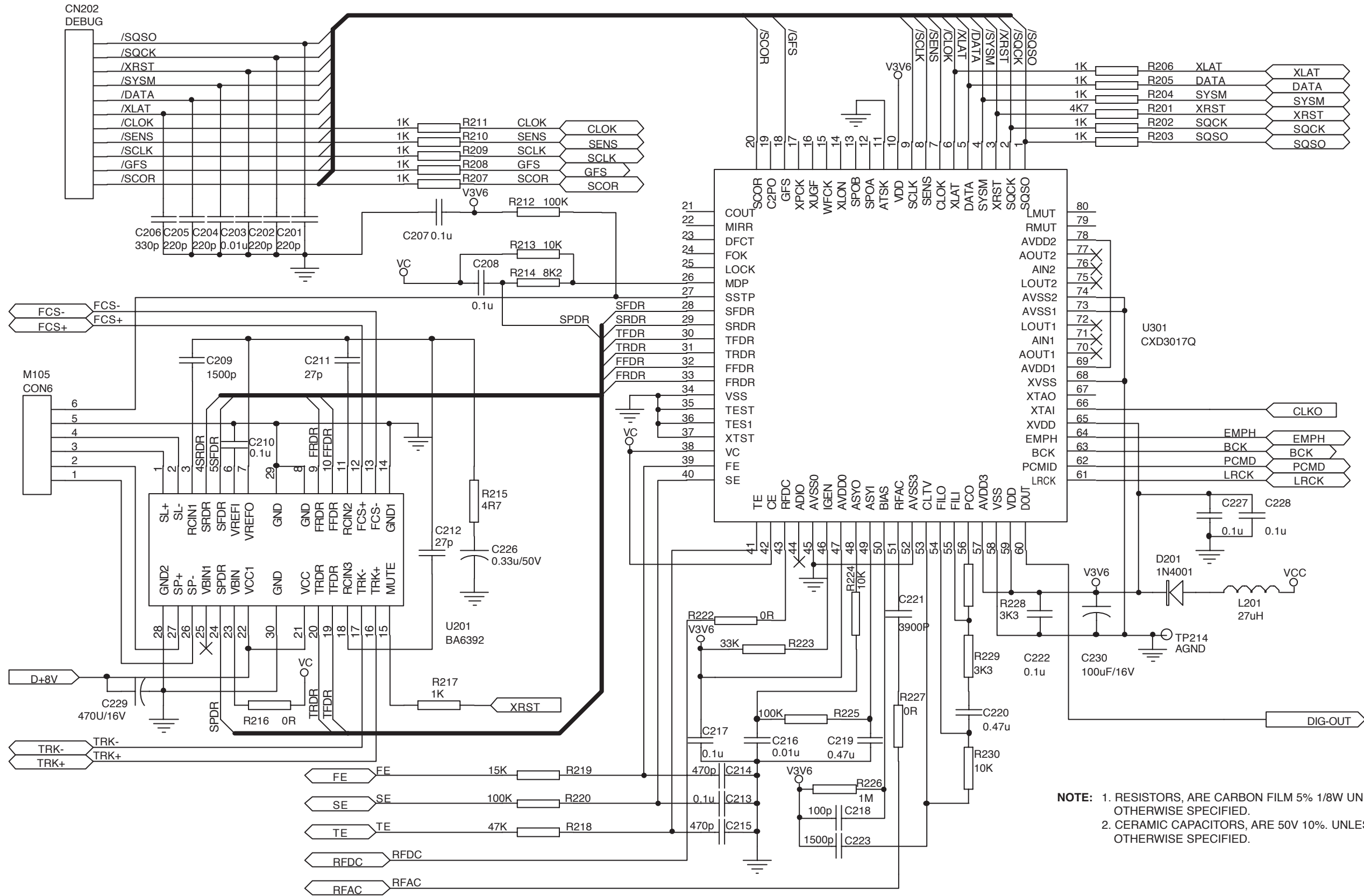

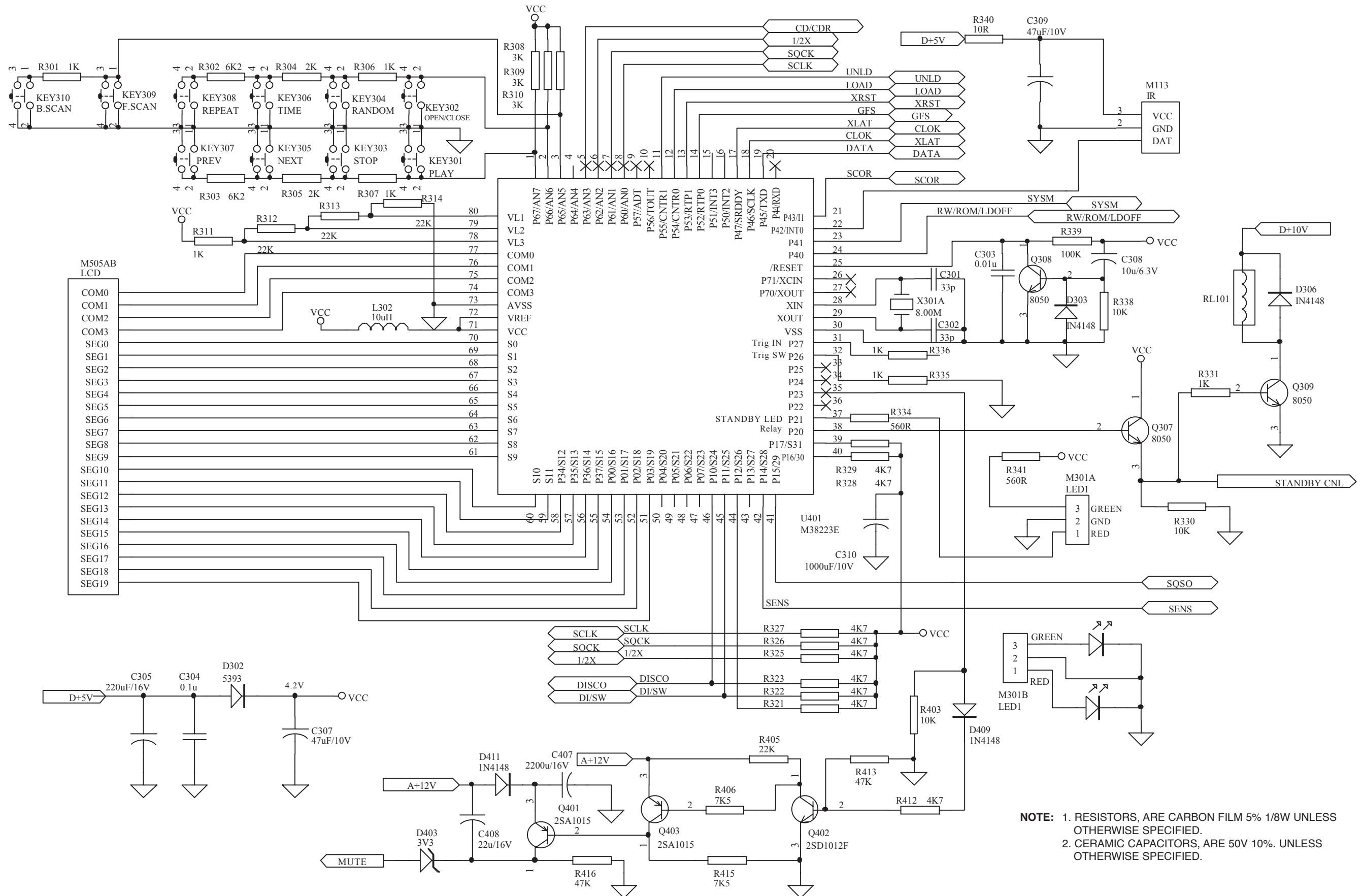

RF AMP

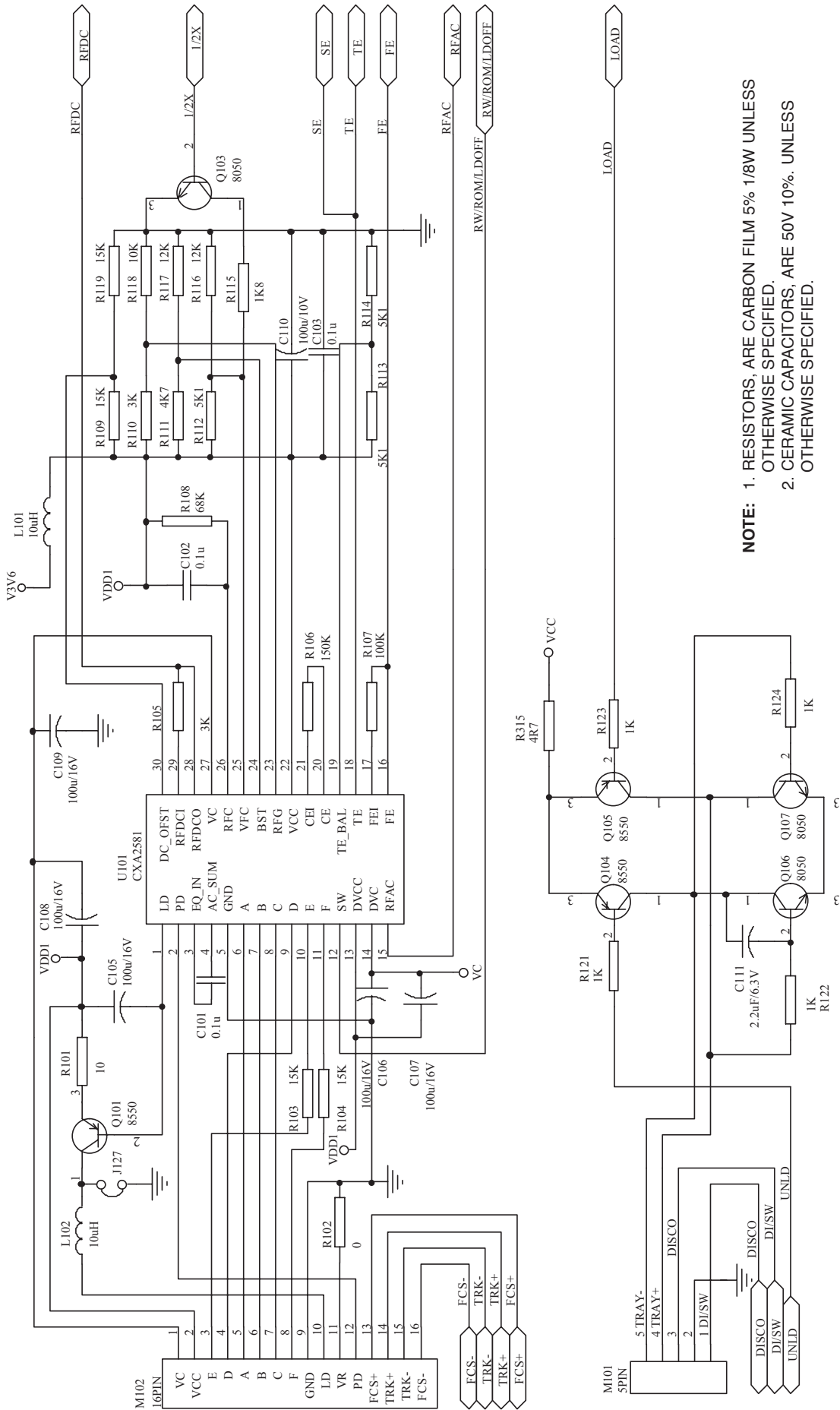

NOTE: 1. RESISTORS, ARE CARBON FILM 5% 1/8W UNLESS OTHERWISE SPECIFIED.
 2. CERAMIC CAPACITORS, ARE 50V 10%. UNLESS OTHERWISE SPECIFIED.

POWER

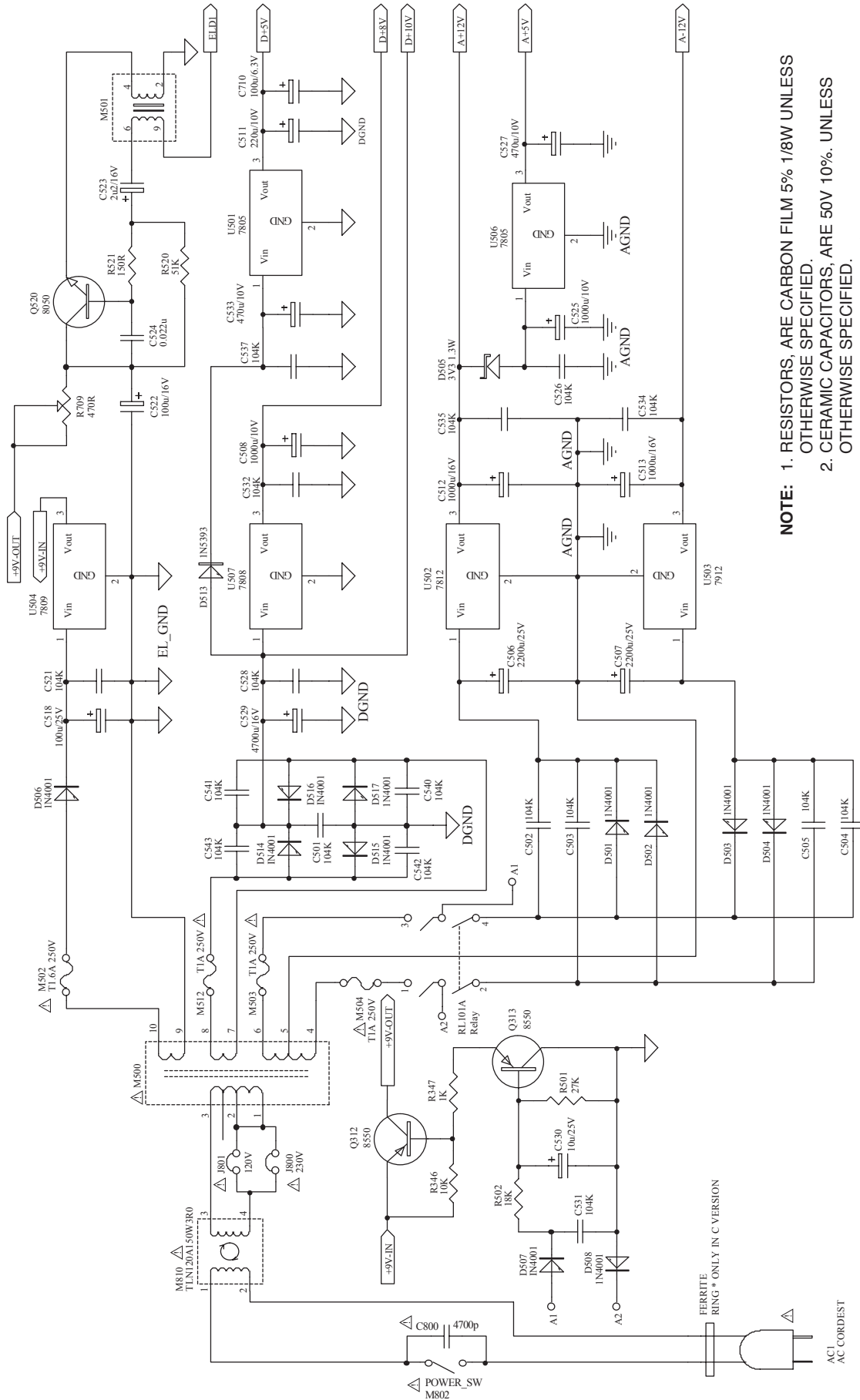

NOTE: 1. RESISTORS, ARE CARBON FILM 5% 1/8W UNLESS OTHERWISE SPECIFIED.
 2. CERAMIC CAPACITORS, ARE 50V 10%. UNLESS OTHERWISE SPECIFIED.
 3. COMPONENTS MARKED "△" ARE SAFETY CRITICAL PARTS.

IC BLOCK DIAGRAM

MAIN BOARD

U101: CXA2581N

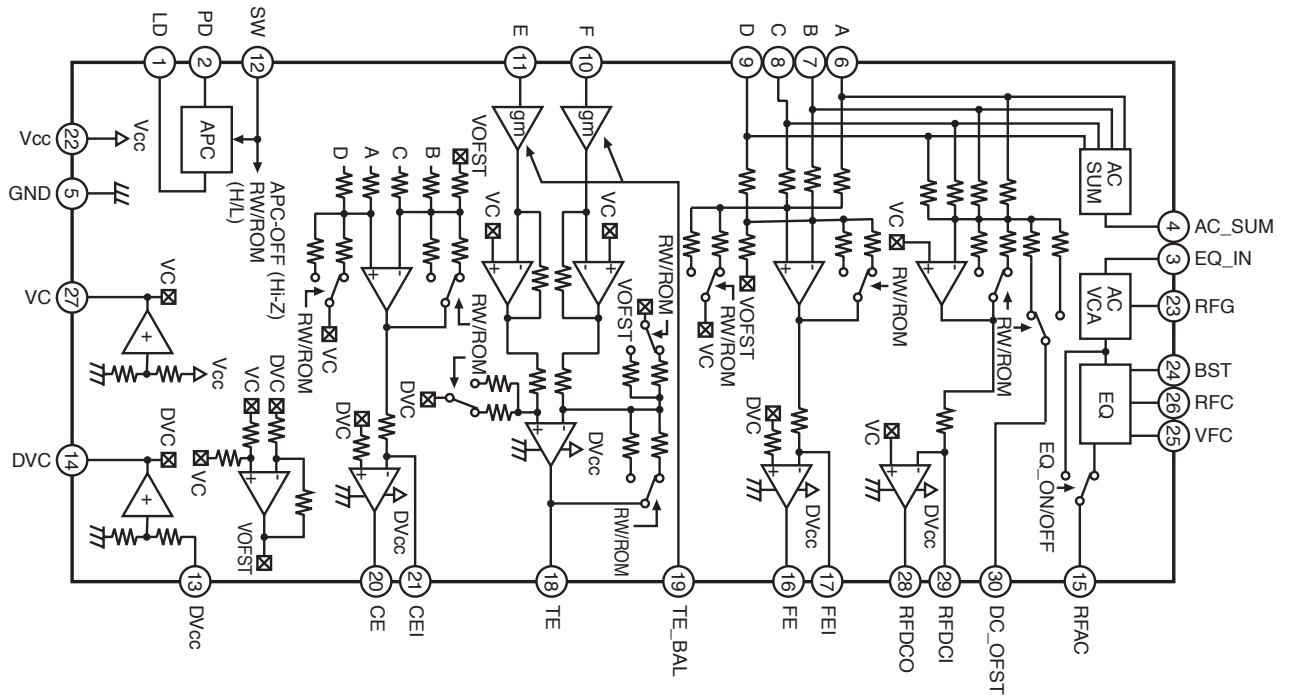

MAIN BOARD

U201: BA6392FP

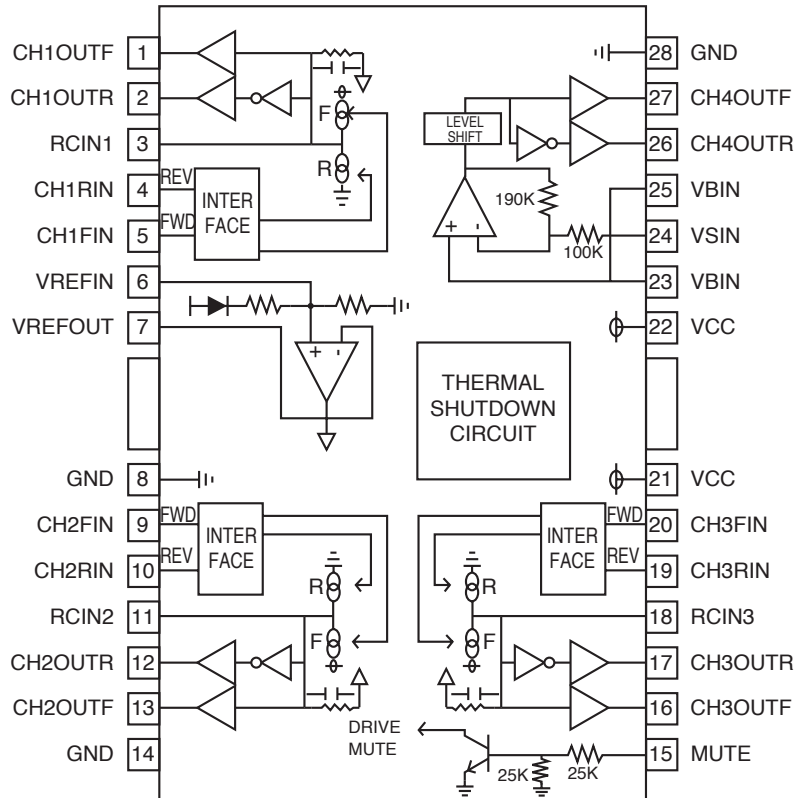

MAIN BOARD
U301: CXD3017Q

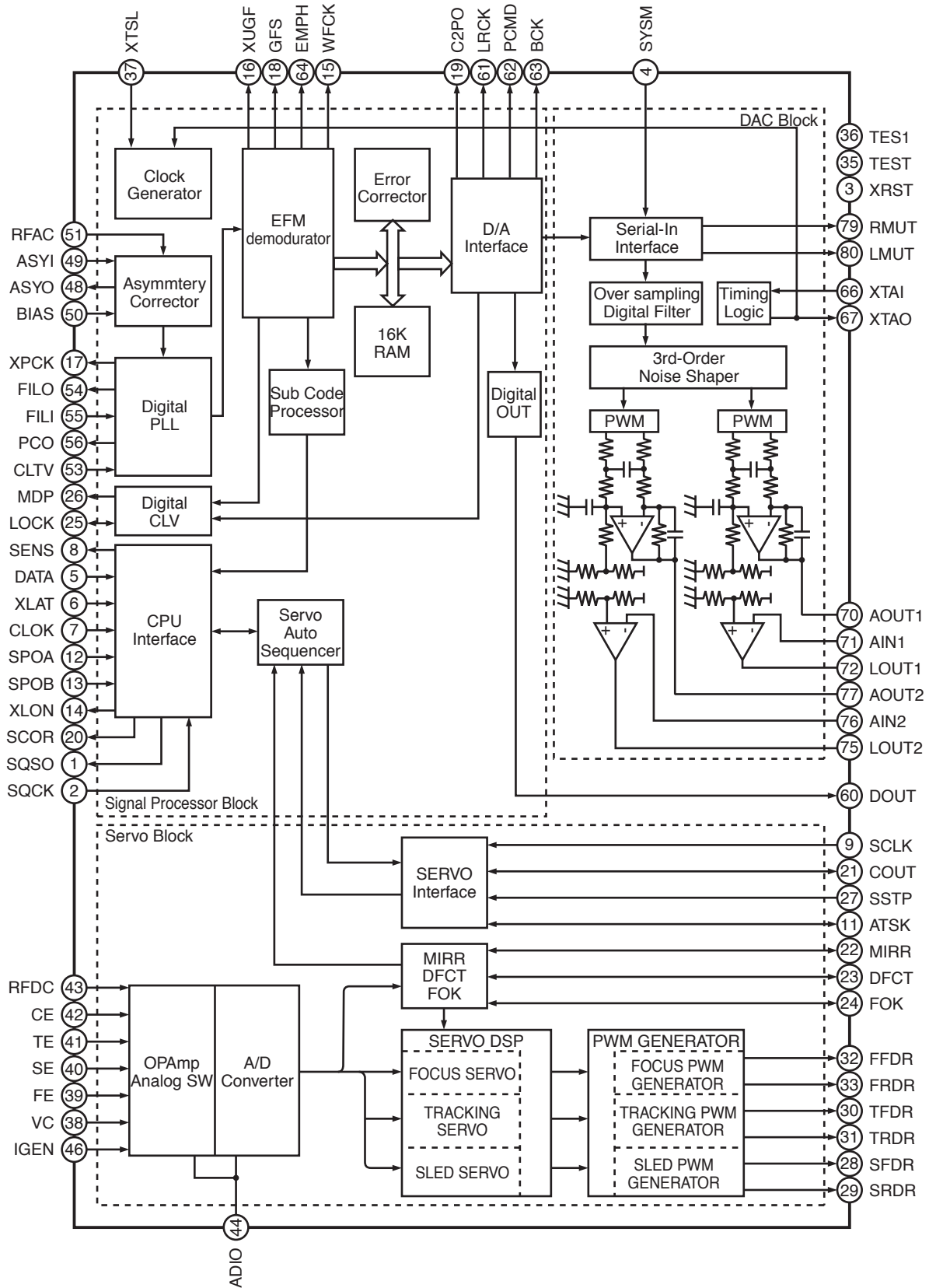

MAIN BOARD
U302: PCM1710U

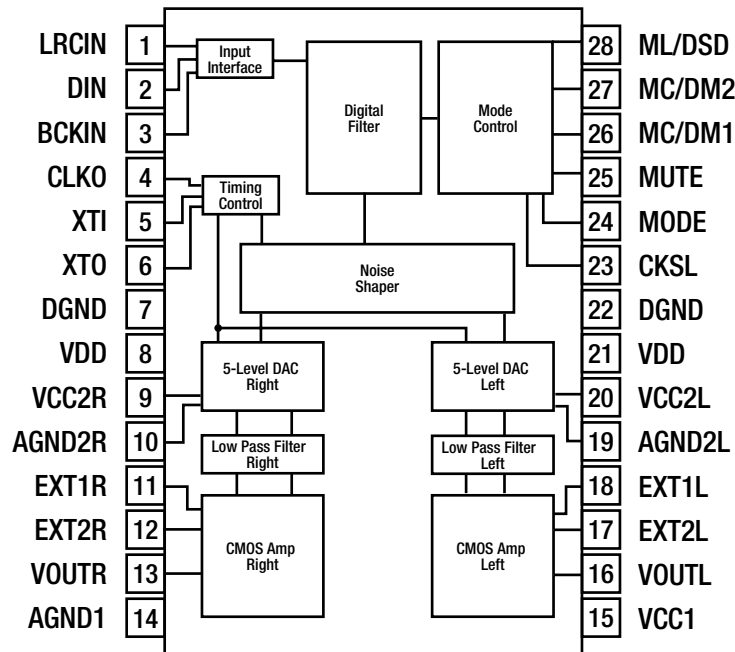

MAIN BOARD
U401: M38223E4HP4

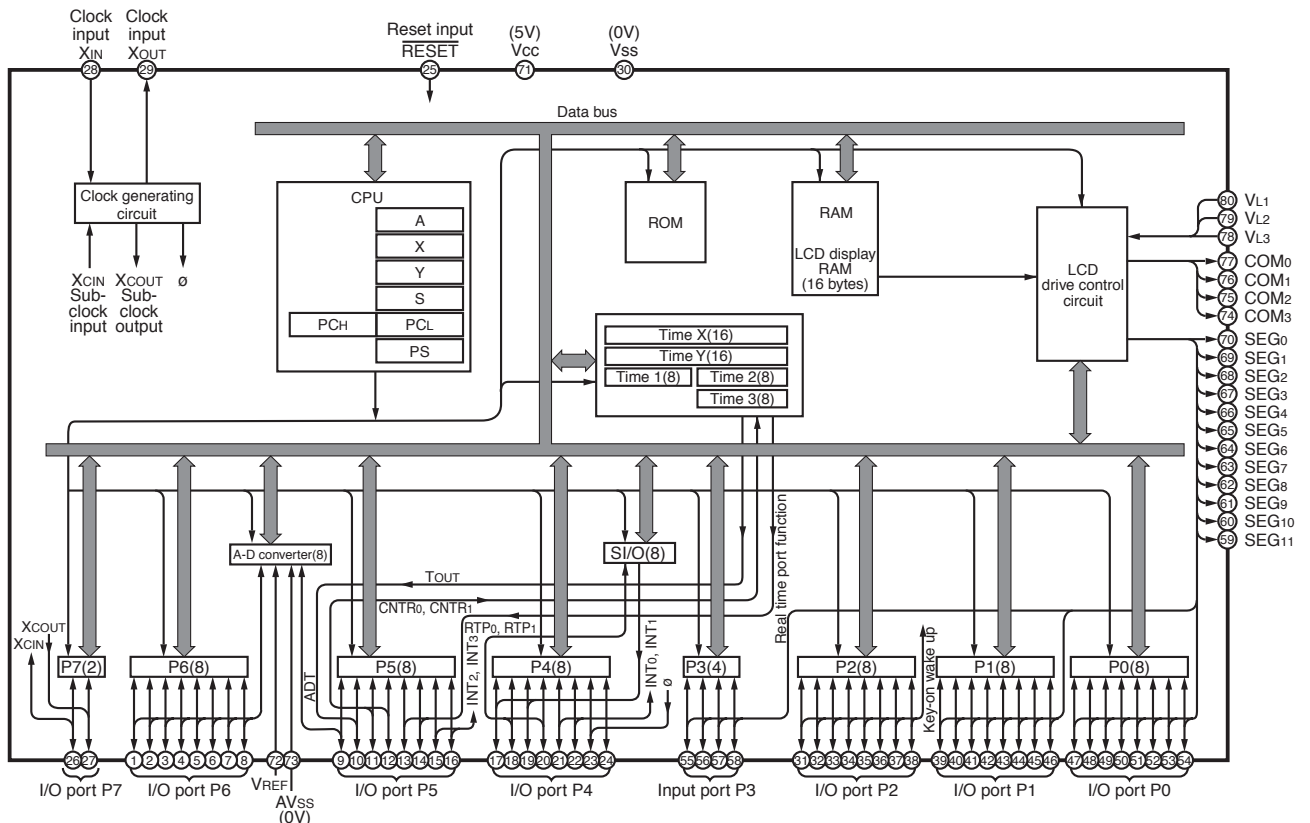

MAIN BOARD

U305, U306: NE5532

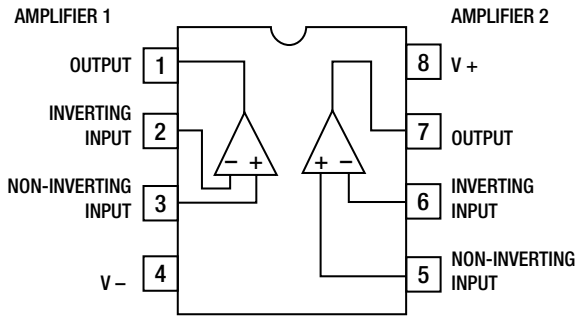

MAIN BOARD

U403: TC74HC00AP

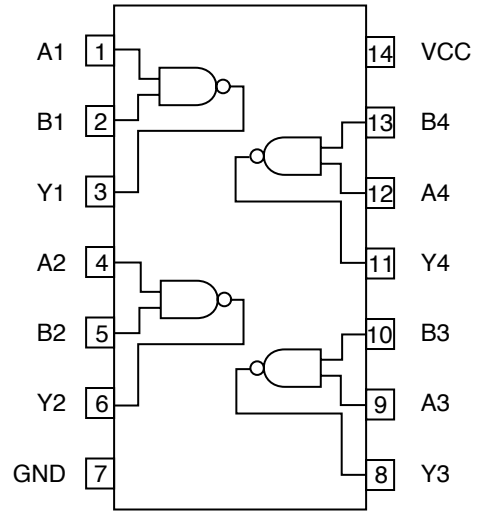

MAIN BOARD

**U501, U502, U504,
U506, U507: 78XX**

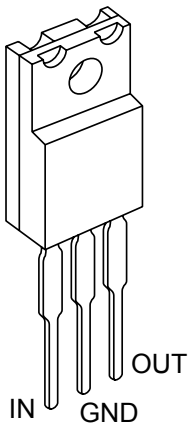

MAIN BOARD

U503: UPC79M12HF

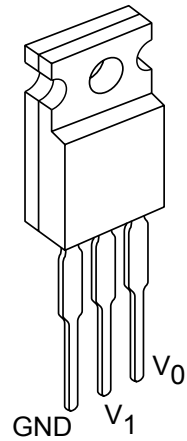

TROUBLESHOOTING GUIDE

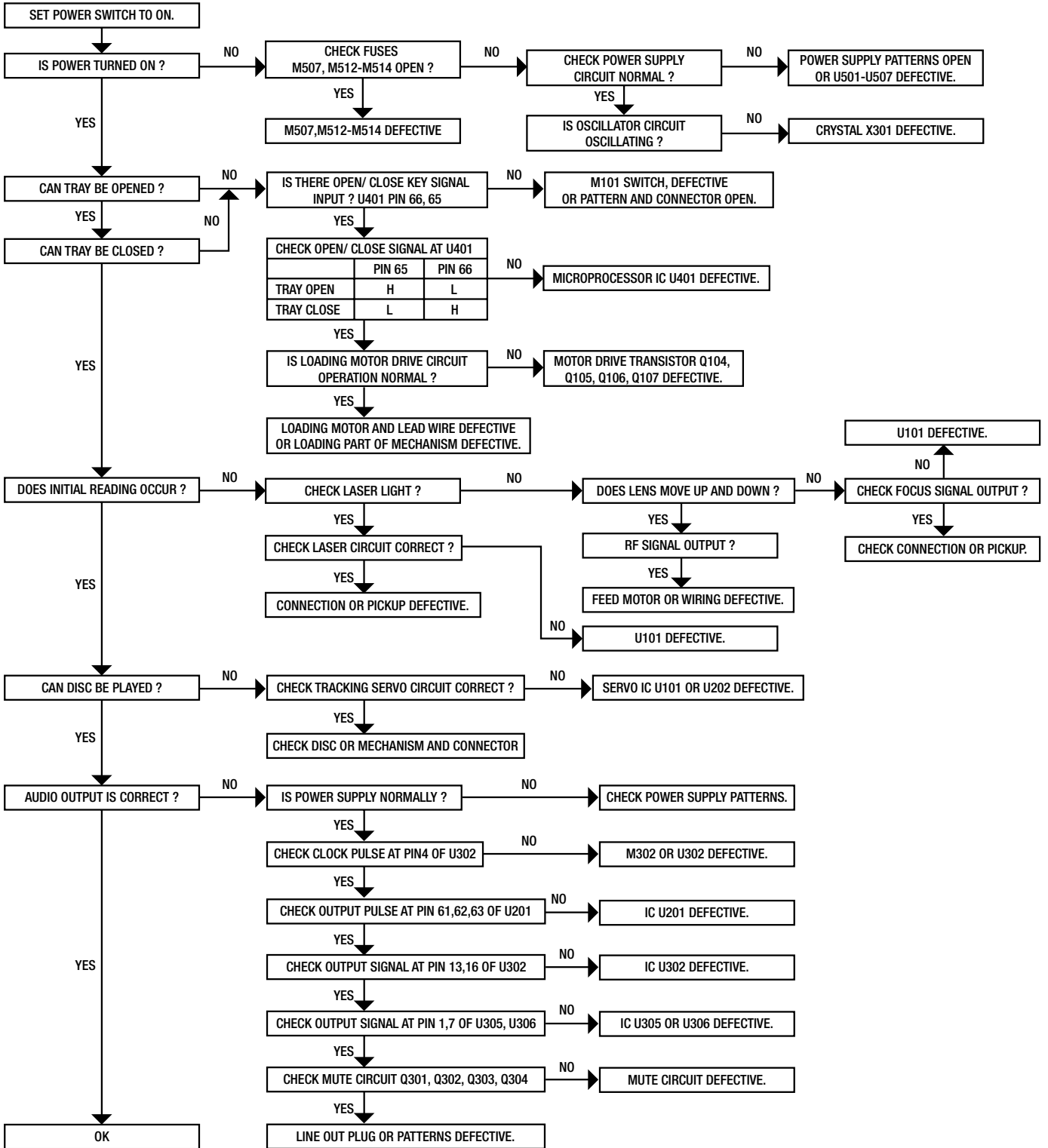

ELECTRICAL PARTS LIST

Location	Part Number	Description
<u>LIVE ASSY</u>		
<i>PC BOARD</i>		
*EU TITANIUM/GREY	PCB-C521B27+LIVE	PCB ASSY LIVE C521BEEC
*CA TITANIUM/GREY	PCB-C521BD7+LIVE	PCB ASSY LIVE C521BEE
<i>CAPACITORS</i>		
C800 ⚠	8910-0049+0	CAP400V 4700P
<i>SWITCH</i>		
M802	5200-3151+0-01	POWER SWITCH
<i>PC BOARD</i>		
	1725-221B+0100	PCB MAIN N0A60C C521 BEE
<i>MISCELLANEOUS</i>		
M801, M803	4132-1071+0	TERMINAL PIN
M804 *EU TITANIUM/GREY	4132-1071+0	TERMINAL PIN
M805 *CA TITANIUM/GREY	4132-1071+0	TERMINAL PIN
M806	4132-1071+0	TERMINAL PIN
M810 EU TITANIUM/GREY	1806-2170+0	EMI FILTER TLN12UA
<u>POWER ASSY</u>		
<i>PC BOARD</i>		
*EU TITANIUM/GREY	PCB-C521B27+PWR	PCB ASSY POWER C521BEEC
*CA TITANIUM/GREY	PCB-C521BD7+PWR	PCB ASSY POWER C521BEE
<i>TRANSFORMER</i>		
M500 ⚠	1806-2194+0	EI-57 TRANSFORMER 740
<i>PC BOARD</i>		
	1723-006A+0000	PCB-TRANSFORMER A0140C
<i>WIRE</i>		
M500A	7012-7310+0	WIRE-CONN 7P P2.5 #26

<u>Location</u>	<u>Part Number</u>	<u>Description</u>
MISCELLANEOUS		
J406, J407	4132-1071+0	TERMINAL PIN
<u>DISPLAY ASSY</u>		
PC BOARD		
	PCB-C521BD7+DISP	PCB ASSY DISPLAY C521BEE
WIRE		
M509A	7010-1300+1	CN ASSY SHIELD 2P P2.5
PC BOARD		
	1725-221B+0100	PCB MAIN N0A60C C521 BEE
WIRE		
M505A, M505B	7009-9630+1	CONN WIRE ASSY 14P 100MM
MISCELLANEOUS		
0011	4134-3011+0	LCD/EL HOLDER
0015	3716-3505+0	PC SHEET FILTER 75X20
0016	3716-3502+0	POLYESTER SHEET LEE
0017	4134-3041+0	LCD CORNER BRACKET
M113	4816-043T+3	IR SENSOR KSM-603TM2
M501	2460-1340+2	LCD DISPLAY NEGATIVE
M502	2450-1146+0	EL BACKLIGHT
<u>KEY ASSY</u>		
PC BOARD		
	PCB-C521BD7+KEY	PCB ASSY KEY C521BEE
RESISTOR		
R301	4711-102A+2	RMF 1/8W 1K 1% AT
R302, R303	4711-622A+2	RMF 1/8W 6.2K 1% AT
R304, R305	4711-202A+2	RMF 1/8W 2K 1% AT
R306, R307	4711-102A+2	RMF 1/8W 1K 1% AT
SWITCH		
M101, M102, M103, M104, M105, M106, M107, M108, M109, M110	5200-3538+0	SWITCH, TACT SKHHBY 7MM

<u>Location</u>	<u>Part Number</u>	<u>Description</u>
<i>WIRE</i>		
M120C	7012-6347+0	CONNECTOR WIRE ASSY
<i>PC BOARD</i>		
	1725-211B+0000	PCB KEY N0A60C
<u>LED ASSY</u>		
<i>PC BOARD</i>		
	PCB-C521BD7+LED	PCB ASSY LED C521BEE
<i>LED</i>		
D304	3700-3517+RG	LED RED/GREEN (L-469HGW)
<i>PC BOARD</i>		
	1725-221B+0100	PCB MAIN N0A60C C521 BEE
<i>WIRE</i>		
M301B	7012-7300+0	WIRE-CONN 3P P2.5 #26
<u>MAIN ASSY</u>		
<i>PC BOARD</i>		
	PCB-C521BD7+MAIN	PCB ASSY MAIN C521BEE
<i>CAPACITORS</i>		
C101, C102, C103	150F-104K+2-FC	CC 50V 0.1UF 10% AT
C105, C106, C107, C108, C109, C110	157D-107M+5-IUI	CE 16V 100UF 20% RL 5X11
C111	157F-225M+5-IUNK	CE 50V 2.2UF 20% RL 5X11
C201, C202	150F-221K+2-FC	CC 50V 220pF 10% AT 3.5x
C203	150F-103K+2-FC	CC 50V 0.01uF 10% AT 3.5
C204, C205	150F-221K+2-FC	CC 50V 220pF 10% AT 3.5x
C206	150F-331K+5-GE	CC 50V 330pF 10% RL 4x3
C207, C208	150F-104K+2-FC	CC 50V 0.1UF 10% AT
C209	153F-152J+5-JM	CM 50V 1500PF 5% RL
C210	150F-104K+2-FC	CC 50V 0.1UF 10% AT
C211, C212	15CH-270J+5-GG	CTC 0/60 27pF 5% RL 4x4
C213	150F-104K+2-FC	CC 50V 0.1UF 10% AT
C214, C215	150F-471K+2-FC	CC 50V 470pF 10% AT 3.5x

Location	Part Number	Description
C216	150F-103K+2-FC	CC 50V 0.01uF 10% AT 3.5
C217	150F-104K+2-FC	CC 50V 0.1UF 10% AT
C218	150F-101K+2-FC	CC 50V 100pF 10% AT 3.5x
C219, C220	150F-474M+5-II	CC 50V 0.47UF 20% RL 5X5
C221	150F-392K+2-GD	CC 50V 0.0039UF 10% AT
C222	150F-104K+2-FC	CC 50V 0.1UF 10% AT
C223	153F-152J+5-JM	CM 50V 1500PF 5% RL
C226	157F-334K+5-IU	CE 50V 0.33uF 10% RL
C227, C228	150F-104K+2-FC	CC 50V 0.1UF 10% AT
C229	157D-477M+K-OVI	CE 16V 470UF 20% RLT
C230	157D-107M+5-IUI	CE 16V 100UF 20% RL 5X11
C301, C302	15CH-330J+5-IG	CTC 0/60 33pF 5% RL 5x4
C303	150F-103K+2-FC	CC 50V 0.01uF 10% AT 3.5
C304	150F-104K+2-FC	CC 50V 0.1UF 10% AT
C305	157D-227M+5-OMK	CE 16V 220uF 20% RL 8x7
C307	157C-476M+5-IU	CE 10V 47uF 20% RL 5x11
C308	157B-106M+5-EI	CE 6.3V 10uF 20% RL 3x5
C309	157C-476M+5-IU	CE 10V 47uF 20% RL 5x11
C310	157C-108M+5-S5	CE 10V 1000uF 20% RL
C320, C321	157B-106M+5-EI	CE 6.3V 10uF 20% RL 3x5
C322	150F-104K+5-II	CC 50V 0.1uF 10% RL 5x5
C323, C324, C325	157B-106M+5-EI	CE 6.3V 10uF 20% RL 3x5
C326, C327	150F-104K+5-II	CC 50V 0.1uF 10% RL 5x5
C328, C329	15CH-200J+5-GG	CTC 0/60 20pF 5% RL 4x4
C330	153F-103J+5-IM	CM 50V 0.01u 5% RL 5X7
C332, C334	157B-106M+5-EI	CE 6.3V 10uF 20% RL 3x5
C352, C353	150F-331K+5-GE	CC 50V 330pF 10% RL 4x3
C356, C357	153F-272J+5-JM	CM 50V 2700PF 5% RL
C362, C363	153F-472J+5-KM	CM 50V 4700pF 5% RL 6x7
C366, C367	158F-681J+5-KW	CP 50V 680pF 5% RL 6x12
C368, C369	157E-226K+5-IU	CE 25V 22uF 10% RL 5x11
C370	153F-103J+5-IM	CM 50V 0.01u 5% RL 5X7
C371, C372, C373, C374	157D-477M+K-OVI	CE 16V 470UF 20% RLT
C375, C376	157E-226K+5-IU	CE 25V 22uF 10% RL 5x11
C377, C378, C379	153F-224J+5-MIB	CM 50V 0.22uF 5% RL 7x5
C380, C381	150F-104K+5-II	CC 50V 0.1uF 10% RL 5x5
C382	153F-224J+5-MIB	CM 50V 0.22uF 5% RL 7x5
C383	157C-226M+5-IU	CE 10V 22uF 20% RL 5x11
C384	150F-102K+2-FC	CC 50V 1000pF 10% AT 3.5
C385	150F-222K+2-GD	CC 50V 0.0022UF 10% AT

Location	Part Number	Description
C386	150F-104K+2-FC	CC 50V 0.1uF 10% AT
C387	150F-103K+2-FC	CC 50V 0.01uF 10% AT 3.5
C390, C391	157D-477M+K-OVI	CE 16V 470UF 20% RLT
C407	157D-228M+5-X=I	CE 16V 2200UF 20% RL
C417	150F-104K+5-II	CC 50V 0.1uF 10% RL 5x5
C418	157E-106M+5-IU	CE 25V 10uF 20% RL 5x11
C501, C502, C503, C504, C505	150F-104K+5-II	CC 50V 0.1uF 10% RL 5x5
C506, C507	157E-228M+5-X9	CE 25V 2200uF 20% RL
C508	157C-108M+5-S5	CE 10V 1000uF 20% RL
C511	157C-227M+5-KW	CE 10V 220uF 20% RL 6x12
C512, C513	157D-108M+5-S5I	CE 16V 1000uF 20% RL
C518	157E-107M+5-KW	CE 25V 100uF 20% RL 6x12
C521	150F-104K+2-FC	CC 50V 0.1uF 10% AT
C522	157D-107M+5-IUI	CE 16V 100UF 20% RL 5X11
C523	157F-225M+5-IU	CE 50V 2.2uF 20% RL 5x11
C524	153F-223K+5-LQ	CM 50V 0.022uF 10% RL 6.
C525	157C-108M+5-S5	CE 10V 1000uF 20% RL
C526	150F-104K+5-II	CC 50V 0.1uF 10% RL 5x5
C527	157C-477M+5-OW	CE 10V 470uF 20% RL 8x12
C528	150F-104K+5-II	CC 50V 0.1uF 10% RL 5x5
C529	157D-338M+5-W@	CE 16V 3300uF 20% RL
C530	157E-106M+5-IU	CE 25V 10uF 20% RL 5x11
C531, C532	150F-104K+5-II	CC 50V 0.1uF 10% RL 5x5
C533	157D-477M+K-OVI	CE 16V 470UF 20% RLT
C534, C535, C537, C540, C541, C542, C543	150F-104K+5-II	CC 50V 0.1uF 10% RL 5x5
C710	157B-107M+5-KM	CE 6.3V 100uF 20% RL 6x7
DIODES		
D201	4804-0010+2	DIODE W1N4001-A(WA) AT
D301, D303, D306, D409, D411	4804-1480+2	DIODE 1N4148T AT
D302	4805-3930+2	DIODE 1N5393-B 200V 1.5A
D403	4837-3V36+2	DZ 1/2W +-5% 3.3V TEMIC
D501, D502, D503, D504, D506, D507, D508	4804-0010+2	DIODE W1N4001-A(WA) AT
D513	4805-3930+2	DIODE 1N5393-B 200V 1.5A
D514, D515, D516, D517	4804-0010+2	DIODE W1N4001-A(WA) AT
WAFERS/SOCKETS		
M102	2101-3102+0	CONNECTOR FFC 16PIN P1.0
M120	2102-051S+004	5P ST.WAFER
M301A	2102-031S+004	3 PIN ST. WAFER

Location	Part Number	Description
M500A	2102-071S+004	WF T8 DE 7PIN COULOMB
M505A, M505B	2102-141S+004	14P ST. WAFER P=2.5
M509	2102-021S+004	2P ST.WAFER
M509A	2102-022S+008	WAFER 2PIN PITCH=2.54MM
JACKS/SOCKETS		
M317	2113-1300+0	2P RCA JACK W/R AU
M318	2113-1170+0	1P RCA JACK YL AU
COILS		
L201	1801-270K+M	COIL 27 UH,10%,AL,BL7
L301	1802-0450+0	DIGITAL COIL
CRYSTAL		
M302	2300-0110+0	CRYSTAL 16.9344 MHZ
RELAY		
RL101	4500-0200+1	RELAY 2P2T BT-12S 12VDC
TRANSISTOR		
Q101	4860-0060+5	TR SS8550 C/D RL
Q103	4860-0050+K	TR SS8050 C/D RLT
Q104, Q105	4860-0060+5	TR SS8550 C/D RL
Q106, Q107	4860-0050+K	TR SS8050 C/D RLT
Q301, Q302, Q303, Q304	4860-1780+K	TR 2SD655F HFE600-1200
Q305	485C-114E+5	TR DTC114ES
Q307, Q308, Q309	4860-0050+K	TR SS8050 C/D RLT
Q312, Q313	4860-0060+5	TR SS8550 C/D RL
Q401	4860-0660+5	TR 2SA1015-GRF(T5L,T) RL
Q402	4851-012F+5	TR 2SD1012F-SPA HFE
Q403	4860-0660+5	TR 2SA1015-GRF(T5L,T) RL
Q404	485A-114E+5	TR DTA114ES ROHM
Q405	485C-114E+5	TR DTC114ES
Q520	4860-0050+K	TR SS8050 C/D RLT
RESISTOR		
R101	4711-100A+2	RMF 1/8W 10R 1% AT
R103, R104	4701-153J+2	RCF 1/8W 15K 5% AT
R105	4701-302J+2	RCF 1/8W 3K 5% AT
R106	4701-154J+2	RCF 1/8W 150K 5% AT

Location	Part Number	Description
R107	4701-104J+2	RCF 1/8W 100K 5% AT
R108	4701-683J+2	RCF 1/8W 68K 5% AT
R109	4711-153A+2	RMF 1/8W 15K 1% AT
R110	4701-302J+2	RCF 1/8W 3K 5% AT
R111	4701-472J+2	RCF 1/8W 4.7K 5% AT
R112, R113, R114	4701-512J+2	RCF 1/8W 5.1K 5% AT
R115	4701-182J+2	RCF 1/8W 1.8K 5% AT
R116, R117	4701-123J+2	RCF 1/8W 12K 5% AT
R118	4701-103J+2	RCF 1/8W 10K 5% AT
R119	4711-153A+2	RMF 1/8W 15K 1% AT
R121, R122, R123, R124	4701-102J+2	RCF 1/8W 1K 5% AT
R201	4701-472J+2	RCF 1/8W 4.7K 5% AT
R202, R203, R204, R205, R206, R207, R208, R209, R210, R211	4701-102J+2	RCF 1/8W 1K 5% AT
R212	4701-104J+2	RCF 1/8W 100K 5% AT
R213	4701-103J+2	RCF 1/8W 10K 5% AT
R214	4701-822J+2	RCF 1/8W 8.2K 5% AT
R215	4701-4R7J+2	RCF 1/8W 4.7R 5% AT
R217	4701-102J+2	RCF 1/8W 1K 5% AT
R218	4701-473J+2	RCF 1/8W 47K 5% AT
R219	4701-153J+2	RCF 1/8W 15K 5% AT
R220	4701-104J+2	RCF 1/8W 100K 5% AT
R223	4701-333J+2	RCF 1/8W 33K 5% AT
R224	4701-103J+2	RCF 1/8W 10K 5% AT
R225	4701-104J+2	RCF 1/8W 100K 5% AT
R226	4701-105J+2	RCF 1/8W 1M 5% AT
R228, R229	4701-332J+2	RCF 1/8W 3.3K 5% AT
R230	4701-103J+2	RCF 1/8W 10K 5% AT
R308, R309, R310	4701-302J+2	RCF 1/8W 3K 5% AT
R311	4701-102J+2	RCF 1/8W 1K 5% AT
R312, R313, R314	4701-223J+2	RCF 1/8W 22K 5% AT
R315	4701-4R7J+2	RCF 1/8W 4.7R 5% AT
R320	4701-471J+2	RCF 1/8W 470R 5% AT
R321, R322, R323, R325, R326, R327, R328, R329	4701-472J+2	RCF 1/8W 4.7K 5% AT
R330	4701-103J+2	RCF 1/8W 10K 5% AT
R331	4701-102J+2	RCF 1/8W 1K 5% AT
R334	4701-561J+2	RCF 1/8W 560R 5% AT
R335	4701-102J+2	RCF 1/8W 1K 5% AT
R338	4701-103J+2	RCF 1/8W 10K 5% AT
R339	4701-104J+2	RCF 1/8W 100K 5% AT

Location	Part Number	Description
R340	4701-100J+2	RCF 1/8W 10R 5% AT
R341	4701-561J+2	RCF 1/8W 560R 5% AT
R346	4701-103J+2	RCF 1/8W 10K 5% AT
R347	4701-102J+2	RCF 1/8W 1K 5% AT
R353	4711-122A+2	RMF 1/8W 1.2K 1% AT
R354	4701-271J+2	RCF 1/8W 270R 5% AT
R355, R356	4711-682A+2	RMF 1/8W 6.8K 1% AT
R357	4701-271J+2	RCF 1/8W 270R 5% AT
R358	4711-122A+2	RMF 1/8W 1.2K 1% AT
R359, R360	4701-682J+2	RCF 1/8W 6.8K 5% AT
R361, R362	4711-683A+2	RMF 1/8W 68K 1% AT
R363, R364	4701-152J+2	RCF 1/8W 1.5K 5% AT
R367, R368, R371, R372	4701-222J+2	RCF 1/8W 2.2K 5% AT
R373, R374	4701-104J+2	RCF 1/8W 100K 5% AT
R375, R376	4701-151J+2	RCF 1/8W 150R 5% AT
R377, R378	4701-472J+2	RCF 1/8W 4.7K 5% AT
R379, R380	4701-151J+2	RCF 1/8W 150R 5% AT
R381, R382	4701-472J+2	RCF 1/8W 4.7K 5% AT
R383	4701-151J+2	RCF 1/8W 150R 5% AT
R384	4701-750J+2	RCF 1/8W 75R 5% AT
R390, R391, R392, R393	4717-221J+C	RMF 1/2W 220R 5% ATS
R394, R403	4701-103J+2	RCF 1/8W 10K 5% AT
R405	4701-223J+2	RCF 1/8W 22K 5% AT
R406	4701-752J+2	RCF 1/8W 7.5K 5% AT
R407	4701-102J+2	RCF 1/8W 1K 5% AT
R412	4701-472J+2	RCF 1/8W 4.7K 5% AT
R413	4701-473J+2	RCF 1/8W 47K 5% AT
R414	4701-104J+2	RCF 1/8W 100K 5% AT
R415	4701-752J+2	RCF 1/8W 7.5K 5% AT
R416	4701-473J+2	RCF 1/8W 47K 5% AT
R501	4711-273A+2	RMF 1/8W 27K 1% AT
R502	4701-183J+2	RCF 1/8W 18K 5% AT
R520	4701-513J+2	RCF 1/8W 51K 5% AT
R521	4701-151J+2	RCF 1/8W 150R 5% AT
IC		
U101	3131-8030+0	IC CXA2581N ASP FOR CD S
U201	3131-8040+0	IC BA6392FP-E2 4-CHANNEL
U301	3131-8000+0	IC CXD3017Q DSP FOR CD
U302	3130-5660+0	IC PCM1710U/1K D/A

Location	Part Number	Description
U305, U306	3130-9340+0	IC OPA2604 OPAMP DIP8
U403	3130-4160+0	IC TC74HC00AP(F/M)
U501	3130-2020+3	IC MC7805CTG REG 5V 1.5A
U502	3130-2520+2	IC NJM7812FA-#ZZZB
U503	3130-3800+0	IC NJM7912FA-#ZZZB
U504	3130-9030+0	IC REGULATOR NJM78L09L2A
U506	3130-2020+3	IC MC7805CTG REG 5V 1.5A
U507	3130-2790+1	IC NJM7808FA-#ZZZB
SEMI FIXED		
R709	4756-4716+3-06	SVR 470 H3 7X7.6 RH0615C
TRANSFORMER		
M501 	1806-2320+0	TRANSFORMER STEP-UP 5V
HEATSINKS		
U501	5400-9130+0	HEAT SINK FOR 7805 2438-
U502	5400-0831+0	HEATSINK
U503, U506, U507	5400-9130+0	HEAT SINK FOR 7805 2438-
WIRE		
M101	7012-6536+0	CONN WIRE ASSY 5PIN P2.0
M105	7012-6538+0	CONN WIRE ASSY 6PIN P2.0
M102C	7012-6232+1	CABLE FFC 16P P1.0
PC BOARD		
	1725-221B+0100	PCB MAIN N0A60C C521 BEE
IC		
U401	3131-8020+0	IC MCU OTP ROM M38227ECH
MISCELLANEOUS		
	2601-2608+0601	FIBRE WASHER M2.6 0.8T
	2954-2608+3000	SCREW B-TITE BIND M2.6X8
	2954-3008+0000	SCREW B-TITE BIND M3X8
	3000-9812+0	BLANK LABEL (5X10)
	3005-0360+2	RIBBON 60MMX600M TEC
C-GND1	4132-1061+0	SOLDER TAG

Location	Part Number	Description
D505	4840-1140+0	DZ 1.3W 3.3V 5% AT
L101, L102, L302	1801-100K+M-2	COIL 10UH 10% BL7.0 AT
M303	2704-0060+0	EMC FILTER
M320	4132-1061+0	SOLDER TAG
M502, M503, M504, M505	4131-9131+0	FUSE HOLDER 6.5MM PITCH
X301	2703-0280+0	CR 8MHZ CSTLA8M00T55-B0

- NOTE:**
- The components identified by \triangle mark are critical for risk of fire and electrical shock.
Replace only with part number specified.
 - < *CA > : Canadian model only.
 - < *EU > : European model only.
 - Capacitors : CP-Polystyrene, CM-Mylar, CE-Electrolytic, CC-Ceramic, CTC-NPO.
 - Resistors : RMF-Metal Film, RCF-Carbon Film, RWR-Wirewound Metal Oxide.

MECHANISM EXPLODED VIEW

WSL-2130CCM

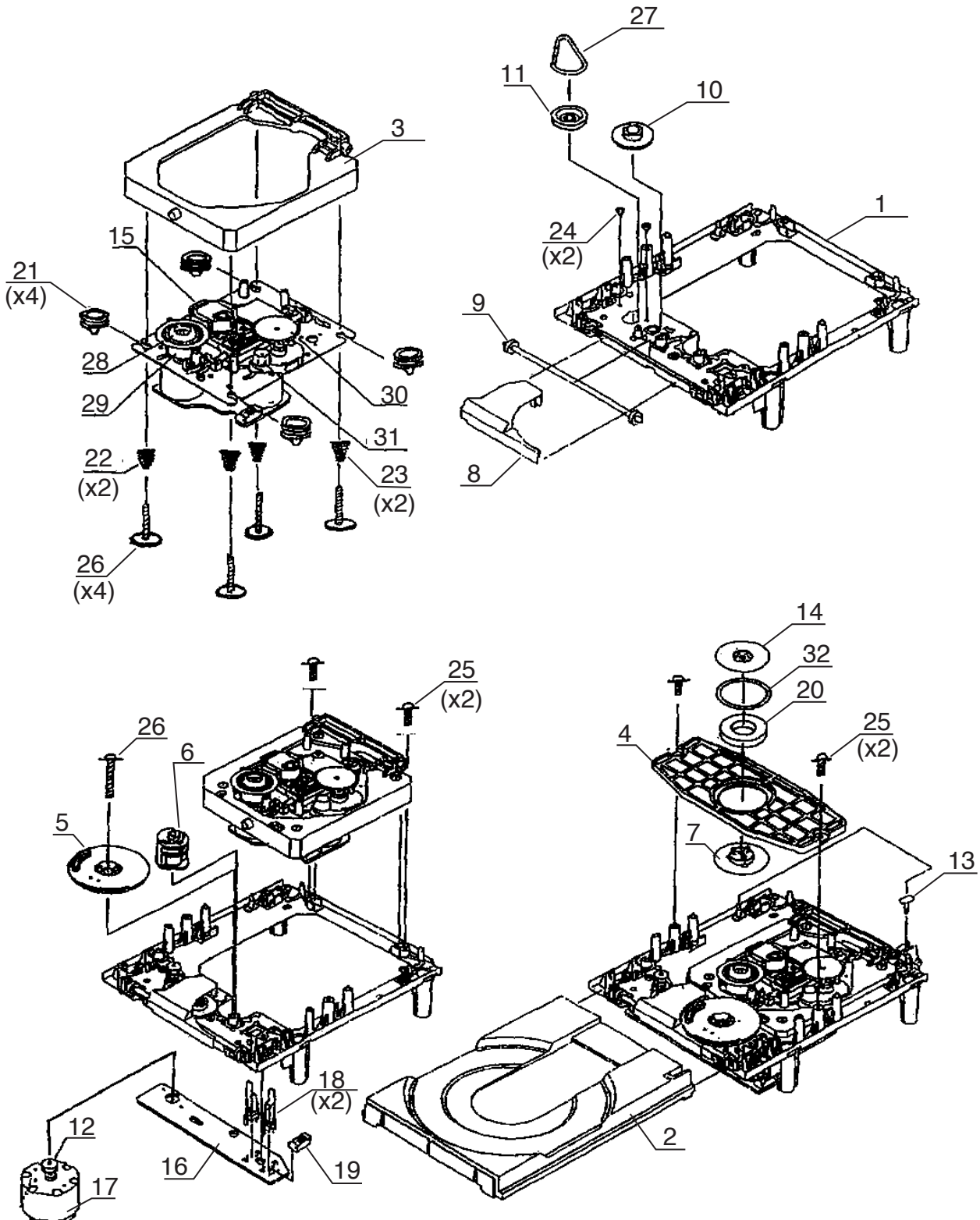

MECHANISM EXPLODED VIEW PARTS LIST

Item	Part No.	Description	Qty
1	4102-9000+0	Outside Main Chassis	1
2	4102-9001+0	Tray	1
3	4102-9002+0	Subchassis	1
4	4102-9003+0	Chucking Plate	1
5	4102-9004+0	Drive Gear	1
6	4102-9005+0	Control Cam	1
7	4102-9006+0	Chucking Pulley	1
8	4102-9007+0	Gear Cover	1
9	4102-9008+0	Tray Gear	1
10	4102-9009+0	Intermediate Gear	1
11	4102-9010+0	Loading Pulley	1
12	4102-9011+0	Motor Pulley	1
13	4102-9012+0	SW Pin	1
14	4102-9013+0	Chucking Yoke	1
15	4102-9014+0	Optical Pickup Unit	1
16	4102-9015+0	Loading PWB	1
17	4102-9016+0	Motor JQ32-55K415, 4.5V, 10G-CM	1
18	4102-9017+0	Leaf Switch	1
19	4102-9018+0	Connector pin (5P)	1
20	4102-9019+0	Magnet	1
21	4102-9020+0	Insulator	4
22	4102-9021+0	Coil Spring (Front)	2
23	4102-9022+0	Coil Spring (Rear)	2
24	4102-9023+0	Screw-Motor M2.6x2.5	2
25	4102-9024+0	Screw M2.6x7	2
26	4102-9025+0	Screw Washer Based M2.6x16	4
27	4102-9026+0	Rubber Belt	1
28	4102-9027+0	Center Ring	1
29	4102-9028+0	Turn Table	1
30	4102-9029+0	Gear (A)	1
31	4102-9030+0	Motor Gear	1
32	4102-9031+0	Damper	1

EXPLODED VIEW

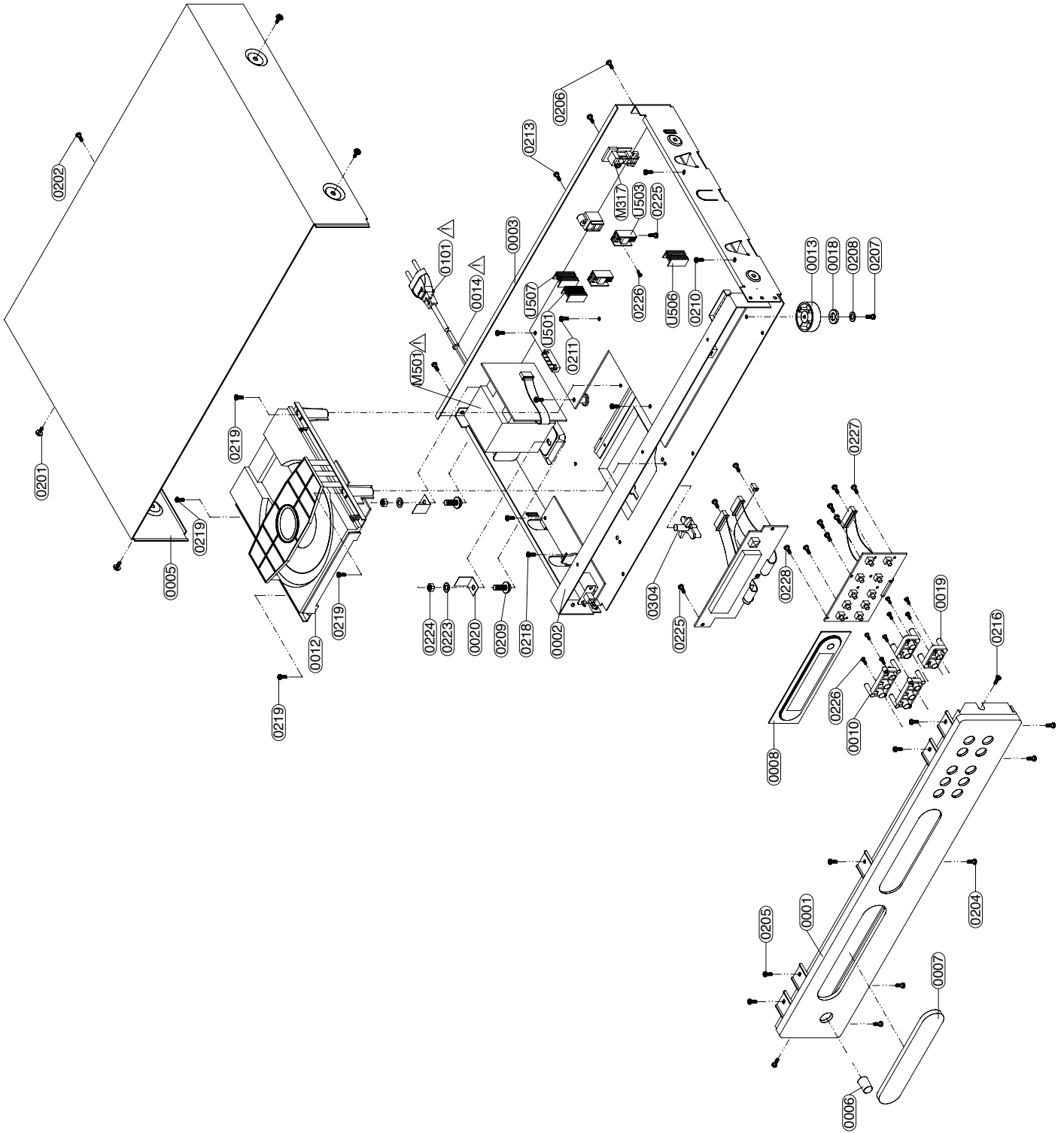

EXPLODED VIEW PARTS LIST

Item	Part No.	Description
0001 *EU GREY / *CA GREY	1466-510A+2	FASCIA BLACK NACDC525B
0001 *EU TITANIUM / *CA TITANIUM	1466-510B+2	FASCIA SILVER NACDC525B
0002	1402-3783+2	STRAP (C542)
0003 *EU TITANIUM/GREY	1402-352I+1	CHASSIS-REAR C NACDC525B
0003 *CA TITANIUM/GREY	1402-352J+1	CHASSIS-REAR AH
0005 *EU TITANIUM / *CA TITANIUM	1402-3532+0	TOP COVER SILVER (C542)
0006 *EU GREY / *CA GREY	2442-1002+0	POWER BUTTON BLACK
0006 *EU TITANIUM / *CA TITANIUM	2442-1003+0	POWER BUTTON SILVER
0007 *EU GREY / *CA GREY	4154-4192+1	CD DOOR BLACK (C521BEE)
0007 *EU TITANIUM / *CA TITANIUM	4154-4194+1	CD DOOR SILVER (C521BEE)
0008 *EU GREY / *CA GREY	3716-4313+0	WINDOW LENS (C520) W/SS
0010 *EU TITANIUM / *CA TITANIUM	2444-1203+0	BUTTON TRIO BLACK
0010 *EU GREY / *CA GREY	2444-1204+0	BUTTON TR10 TITANIUM
0012 *EU TITANIUM / *CA TITANIUM	4111-1051+1	CD DECK WSL-2130CCM
0013	4157-0501+1	RUBBER FOOT
0014 	4151-9461+0	STRAIN RELIEF BUSHING
0018	4152-4641+1	CUSHION FOOT W/RUBBER WA
0019	2444-1903+0	DUO BUTTON BLACK
0019	2444-1904+0	DUO BUTTON TITANIUM
0020	4132-6191+0	BRACKET,MTG,X'FORMER
0023	4154-1931+1	DUSTPROOF CUSHION
0024	3714-5706+0	LED LENS (412) CLEAR SAN
0052	4152-4841+1	BLACK CUSHION (EL/LCD)
0101 *EU GREY / *CA GREY 	1402-3533+0	COVER-TOP BLACK (C542)
0101 *CA TITANIUM/GREY 	7009-3100+2	AC CORD 18AWGX2
0101 *EU TITANIUM/GREY	7009-3110+0	AC CORD (SEMKO)
0160	2600-4008+0973	FLAT WASHER 4*9.7*0.8
0201 *EU TITANIUM / *CA TITANIUM	2900-4006+2010	SCM PW M4X6 RECESS WHITE
0201 *EU GREY / *CA GREY	2900-4006+3010	M4X0.5PX6MM W/FLAT
0202 *EU GREY / *CA GREY	2954-3008+3000	SCREW B-TITE BIND HEAD
0202 *EU TITANIUM / *CA TITANIUM	2954-3010+4000	ST SCREW 3X10 BH
0204	2954-3008+3000	SCREW B-TITE BIND HEAD
0205	2954-3008+0000	SCREW B-TITE BIND M3X8
0206, 0207	2954-3008+3000	SCREW B-TITE BIND HEAD
0208	2842-3367+0	METAL WASHER
0209	2900-4010+3030	PH W/WASHER M4X10 BL ZN
0210	2954-3008+0000	SCREW B-TITE BIND M3X8
0211	2904-3006+0000	SCREW M3X6
0213	2954-3008+3000	SCREW B-TITE BIND HEAD
0216	2954-3008+0000	SCREW B-TITE BIND M3X8

Item	Part No.	Description
0217	2842-3367+0	METAL WASHER
0218	2954-3006+0000	3X6MM B-TITE (YEL.ZN)
0219	2904-3006+3000	SCREW M3X6 BINDING (BLK)
0223	2600-4008+0973	FLAT WASHER 4*9.7*0.8
0224	2640-4030+0703	M4 NUT (BLK)
0225	2954-3008+0000	SCREW B-TITE BIND M3X8
0226	2954-2006+0000	TAPPING SCREW 2X6
0227	2954-2608+0000	SCREW B-TITE BIND M2.6X8
0228	2600-4008+0973	FLAT WASHER 4*9.7*0.8
0230	2954-3008+0000	SCREW B-TITE BIND M3X8
0301	4153-3331+0	EVA GASKET 5*500
0309	3100-5101+0	PC SHEET 50X7X0.25
0310	1635-0110+0	TAPE HIGH TEMP W=12
0311	4152-0241+0	PAD CORK 15X12X3MM GRAY
0312	4154-1401+0	PC SHEET 14X350X0.5 THK
0315	3100-5101+0	PC SHEET 50X7X0.25
0316	4154-1371+0	PC SHEET 14X260X0.5 THK
0317	4157-0751+0	TRANSFORMER RUBBER PAD
0500 *CA TITANIUM/GREY	3000-4290+0	LABEL, BLANK 45X10
0500 *CA TITANIUM/GREY	3005-0360+2	RIBBON 60MMX600M TEC
0501	3009-1689+0	CD LASER LABEL YELLOW
0502	3000-4205+0	LABEL, CD WARNING
M502, M503, M504 *EU TITANIUM/GREY △	5120-0018+0	FUSE T1A 250V 5X20
M502, M503, M504 *CA TITANIUM/GREY △	5120-0020+0	FU T1A 250V UL/CSA 5X20
M505 *EU TITANIUM/GREY △	5120-0050+0	FUSE T1.6A/250V 5X20
M505 *CA TITANIUM/GREY △	5120-0052+0	FUSE T1.6A 250V 5X20

- NOTE:**
- The components identified by △ mark are critical for risk of fire and electrical shock. Replace only with part number specified.
 - <*CA > : Canadian model only.
 - <*EU > : European model only.

PACKING DIAGRAM

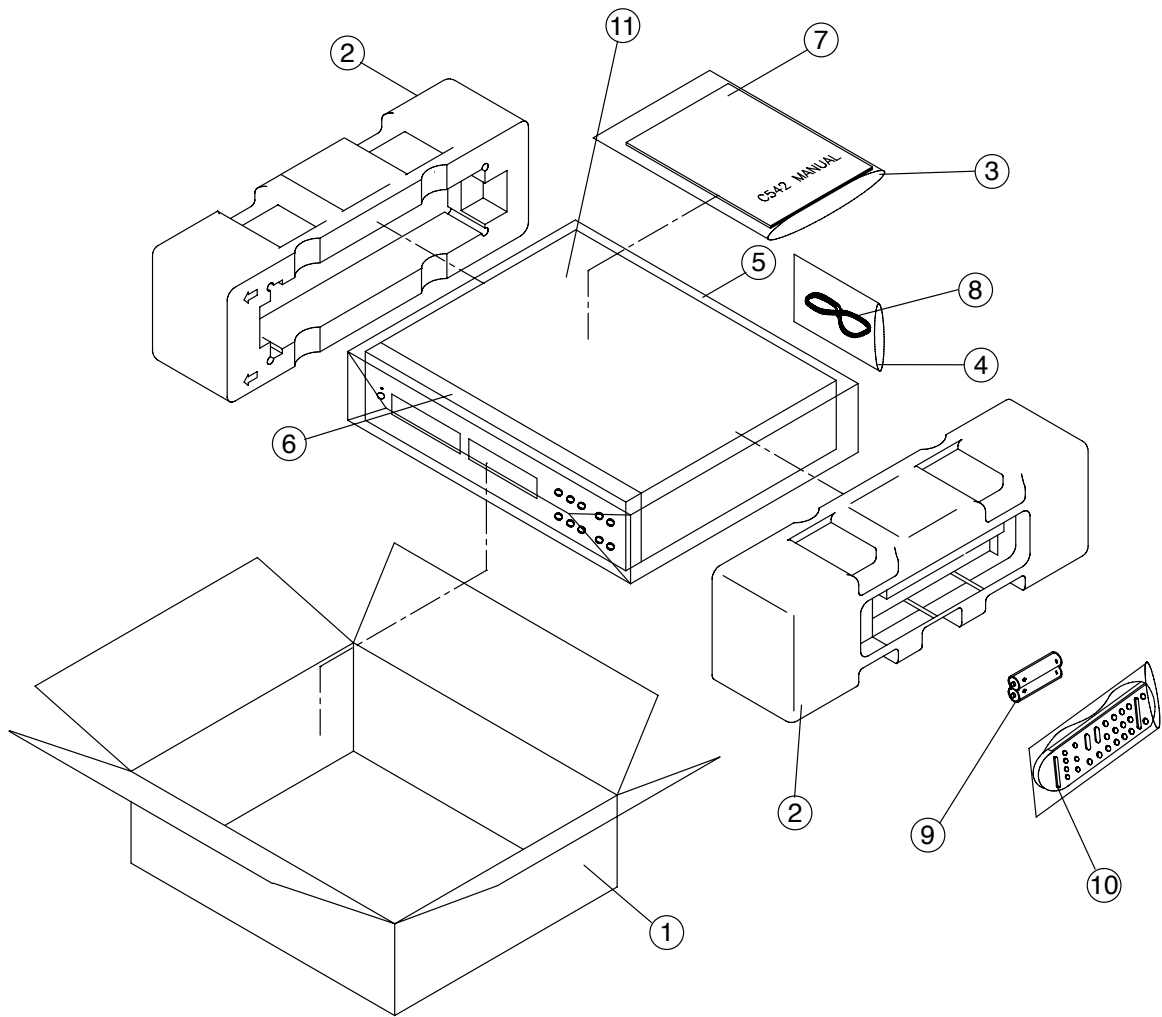

ITEM	PART NO.	DESCRIPTION	Q'TY
1.	1435-8302+0-2	CARTON BOX C525BEE	1
2.	1490-3783+2	POLYFORM ENDCAP	2
3.	1497-1062-0	POLYBAG MANUAL	1
4.	1497-1302+0	POLYBAG	1
5.	1497-1332+1	POLYBAG	1
6.	1497-1432+0	EPE BAG (412)	1
7.	4301-7231+0	INSTRUCTION MANUAL	1
8.	2103-7302+1	RCA PLUG (MALE)	1
9.	4060-0530+0	GREENCELL 3A SIZE GP24G2	2
10.	8912-0038+0	REMOTE CONTROL C521BEE	1
11.	1450-2520+0	WHITE PAPER	1

Proprietary information for servicing purposes only. The information herein may not be used commercially without the prior written agreement of NAD Electronics International, Toronto, Canada.