

**C 541i**

**COMPACT  
DISC PLAYER**

**C 541i**

**COMPACT  
DISC PLAYER**

**SERVICE MANUAL**



# SAFETY INFORMATION

## CAUTION

**CAUTION** - INVISIBLE LASER RADIATION WHEN OPEN AND INTERLOCKS DEFEATED. AVOID EXPOSURE TO BEAM.

**ADVARSEL** - USYNLIG LASERSTRÅLING NÅR DEKSEL ÅPNES OG SIKKERHEDSLÅS BRYTES. UNNGÅ EKSPONERING FOR STRÅLEN.

**ADVARSEL** - USYNLIG LASERSTRÅLING VED ÅBNING, NÅR SIKKERHEDSAFBRYDERE ER UDE AF FUNKTION. UNDGÅ UDSÆTTELSE FOR STRÅLING.

**VARING** - OSYNLIG LASERSTRÅLNING NÅR DENNA DEL ÄR ÖPPNAD OCH SPÄRRAR ÄR URKOPPLADE. STRÅLEN ÄR FARLIG.

**VARO!** - AVATTAESSA JA SUOJALUKITUS OHITETTAESSA OLET ALTTIINA NÄKTMÄTÖNTÄ LASERSÄTELYLLE. ÄLÄ KAISO SÄTEESEEN.

**VORSICHT!** - UNSICHTBARE LASERSTRAHLUNG TRITTT AUS, WENN DECKEL GEÖFFNET UND WENN SICHERHEITVERRIEGELUNG ÜBERBRÜCKT IST. NICHT DEM STRAHL AUSSETZEN.

**CLASS 1  
LASER PRODUCT**

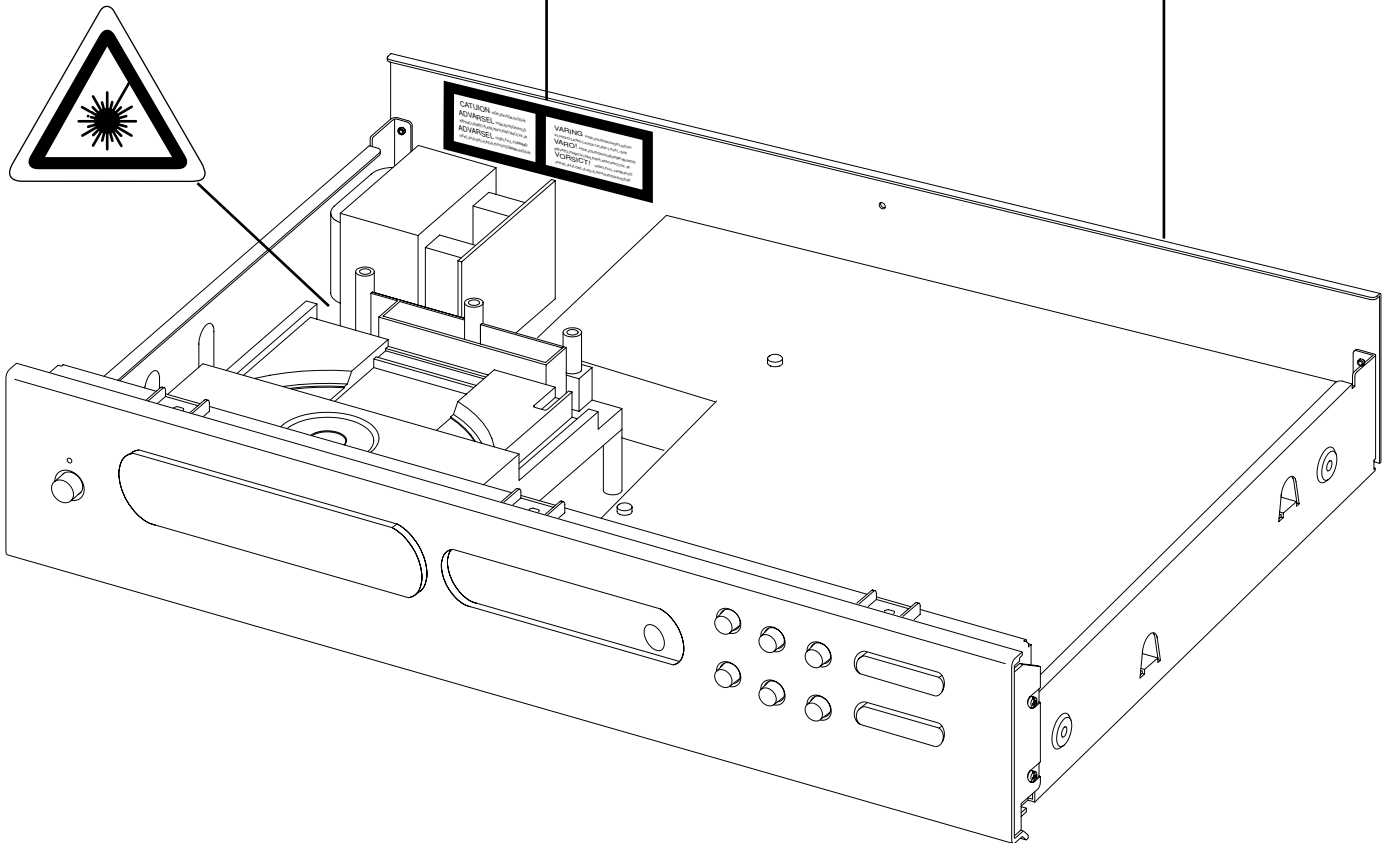

The lightning flash with arrowhead, within an equilateral triangle is intended to alert the user of the presence of uninsulated "dangerous voltage" within the product's enclosure; that may be of sufficient magnitude to constitute a risk of electric shock to persons.



The exclamation point within an equilateral triangle is intended to alert the user of the presence of important operating and maintenance (servicing) instructions in the literature accompanying the appliance.

THIS DEVICE COMPLIES WITH PART 15 OF THE FCC RULES. OPERATION IS SUBJECT TO THE FOLLOWING TWO CONDITIONS:-  
(1) THIS DEVICE MAY NOT CAUSE HARMFUL INTERFERENCE, AND  
(2) THIS DEVICE MUST ACCEPT ANY INTERFERENCE RECEIVED, INCLUDING INTERFERENCE THAT MAY CAUSE UNDESIRE OPERATION.

# SERVICE SAFETY PRECAUTIONS

## 1. Replacing the fuses

**CAUTION:** FOR CONTINUED PROTECTION AGAINST THE RISK OF FIRE REPLACE ONLY WITH SAME TYPE OF FUSE.

Reference No		Part Number	Description
M507	*AH $\triangle$	5120-0052-0	FUSE T1.6A 250V 5x20MM
M507	*C $\triangle$	5120-0050-0	FUSE T1.6A 250V 5x20MM
M512, M513	*AH $\triangle$	5120-0020-0	FU T1A 250V UL/CSA 5x20MM
M512, M513	*C $\triangle$	5120-0018-0	FU T1A 250V SEMKO/VDE
M514	*AH $\triangle$	5120-0026-0	FU T315MA L 250V UL/CSA
M514	*C $\triangle$	5120-0027-0	FU T315MA L 250V

NOTE:

<\*AH > : USA, CANADIAN MODEL ONLY.

<\*C > : EUROPEAN MODEL ONLY.

## 2. Safety check out

(Only U.S.A. model)

Before returning the product to the customer, make leakage current or resistance measurements to determine that exposed parts are acceptably insulated from the supply circuit.

Parts marked with the symbol  $\triangle$  are critical with regard to the risk of fire and electric shock. Replace only with parts recommended by the manufacturer.

## CONTENTS

DESCRIPTION	PAGE
SPECIFICATIONS .....	4
REAR PANEL / FRONT PANEL .....	5
DISASSEMBLY INSTRUCTIONS .....	6
BLOCK DIAGRAM .....	7
WIRING DIAGRAM .....	8
RF PATTERN TESTING .....	9
IMPORTANT NOTES .....	10-11
PCB LAYOUT .....	12-14
SCHEMATIC DIAGRAM .....	15-21
IC BLOCK DIAGRAM .....	22-26
TROUBLESHOOTING GUIDE .....	27
ELECTRICAL PARTS LIST .....	28-33
MECHANISM EXPLODED VIEW .....	34
MECHANISM EXPLODED VIEW PARTS LIST .....	35
EXPLODED VIEW .....	36
EXPLODED VIEW PARTS LIST .....	37
PACKING DIAGRAM .....	38

# SPECIFICATIONS

Disc Capacity	One Disc, 120 or 80 mm
Decoding	BURR-BROWN Delta Sigma 24bit
Digital Filter	8 Times oversample
Analog Filter	4 pole active
Frequency Response	+/- 0.5 dB, 5Hz - 20kHz
De-Emphasis Error	+/- 0.3 dB
THD (at 0 dB, 1kHz)	0.002%
Intermodulation Distortion	< - 100 dB
(19 + 20 kHz)	
Dynamic Range	96 dB
Linearity	+/- 0.5 dB, 0 dB to -80 dB
Signal / Noise Ratio (A-Weight)	≥100 dB, De-Emphasis on ≥100 dB, De-Emphasis off
Channel Separation 1kHz	>90 dB
10 kHz	>80 dB
Wow and Flutter	Unmeasurable (Quartz Crystal Accuracy)
Output Impedance	200 Ω
Output Level at 0 dB	2.2 V rms
Digital Error Correction	IRC with double error correction in C1 and C2
Digital Code Output	Sony / Philips Serial data format
Power Consumption	12W

## CONTROLS

Play / Pause, Stop, Random, Skip (< >), Scan (< >), Open, Time, Repeat.

## PHYSICAL SPECIFICATIONS

Dimensions (Width x Height x Depth)	435 x 80 x 285 mm
Net weight	4 kg (8.8 lbs)
Shipping weight	5.1 kg (11.22 lbs)

# REAR PANEL / FRONT PANEL

## REAR PANEL

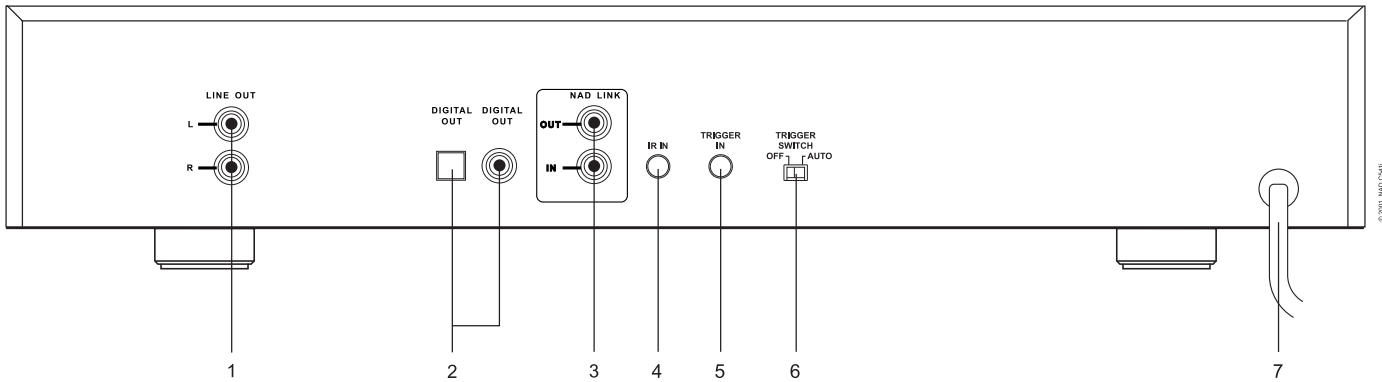

- |                                     |                   |
|-------------------------------------|-------------------|
| 1. LINE OUT                         | 5. TRIGGER IN     |
| 2. DIGITAL OPTICAL & COAXIAL OUTPUT | 6. TRIGGER SWITCH |
| 3. NAD LINK IN / OUT                | 7. AC LINE CORD   |
| 4. IR INPUT                         |                   |

## FRONT PANEL

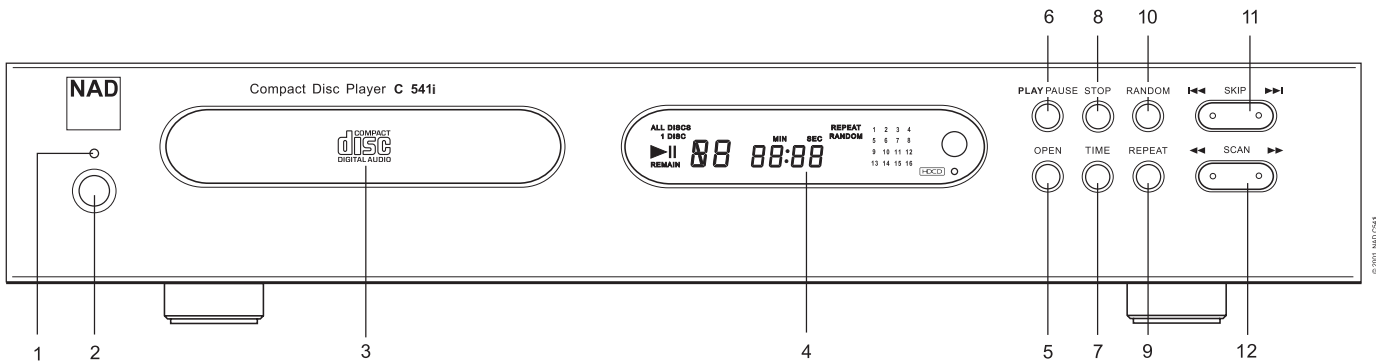

- |                   |                                     |
|-------------------|-------------------------------------|
| 1. POWER ON / OFF | 7. STOP                             |
| 2. DISC DRAWER    | 8. REPEAT                           |
| 3. DISPLAY        | 9. RANDOM                           |
| 4. OPEN           | 10. SCAN Back (◀◀) / Forward (▶▶)   |
| 5. PLAY / PAUSE   | 11. SKIP Back (◀◀◀) / Forward (▶▶▶) |
| 6. TIME           | 12. STANDBY LED                     |

# DISASSEMBLY INSTRUCTIONS

1. Remove machine screws M 4.0 x 6.0 ( ① to ④ ) from the side panels.  
Remove tapping screw 3.0 x 8.5 ( ⑤ ) from the back panel.  
Refer to **Figure No.1**.

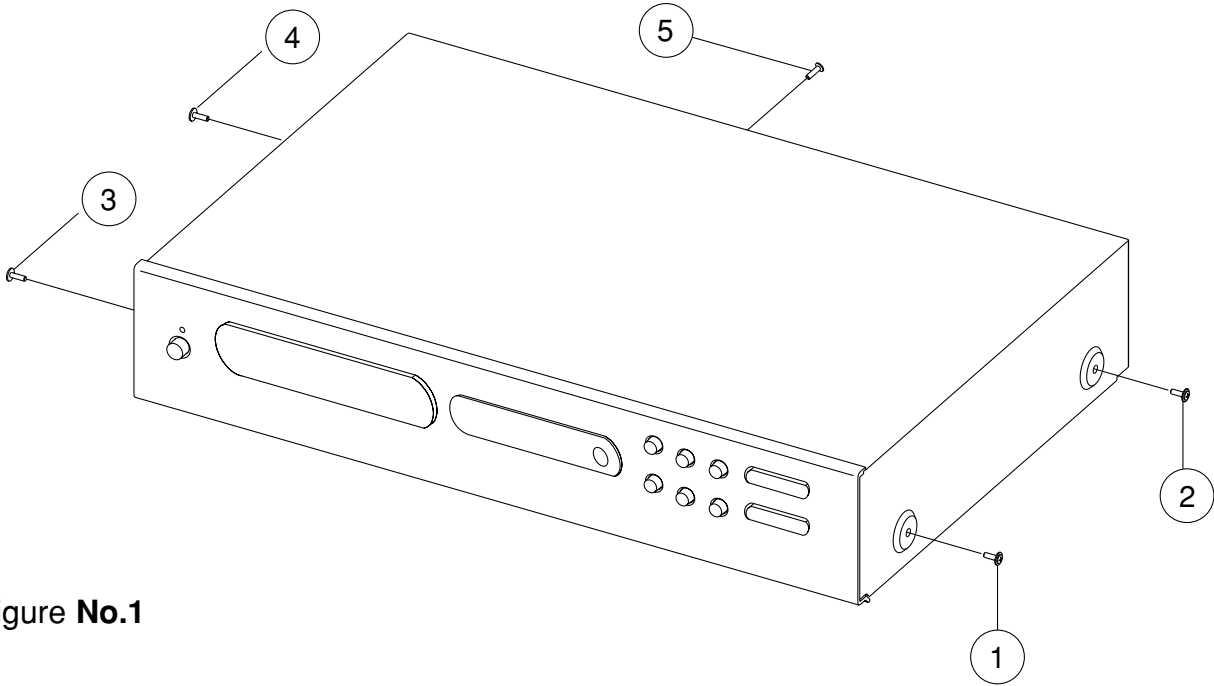

Figure No.1

2. Pull both sides of the TOP COVER slightly outwards ( ⑥ ) and tilt approx. 35° and then remove in the direction as indicated by the arrow ( ⑦ ). Refer to **Figure No.2**.

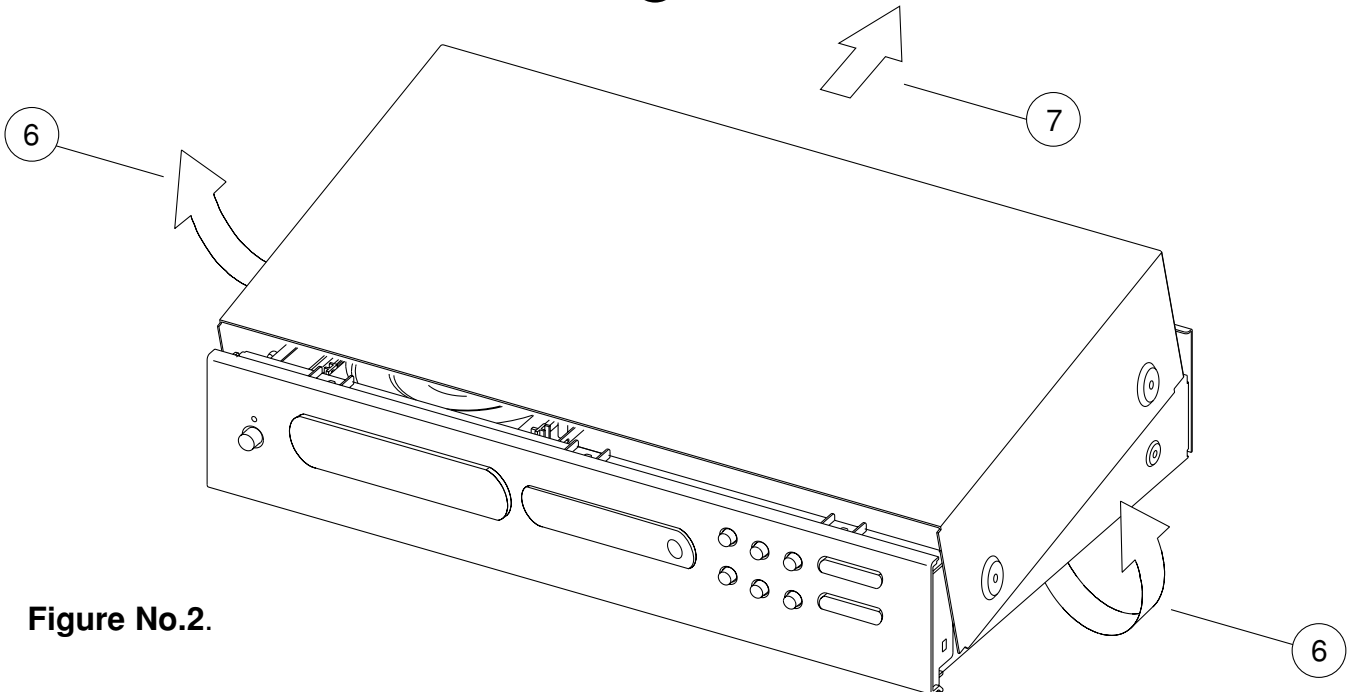
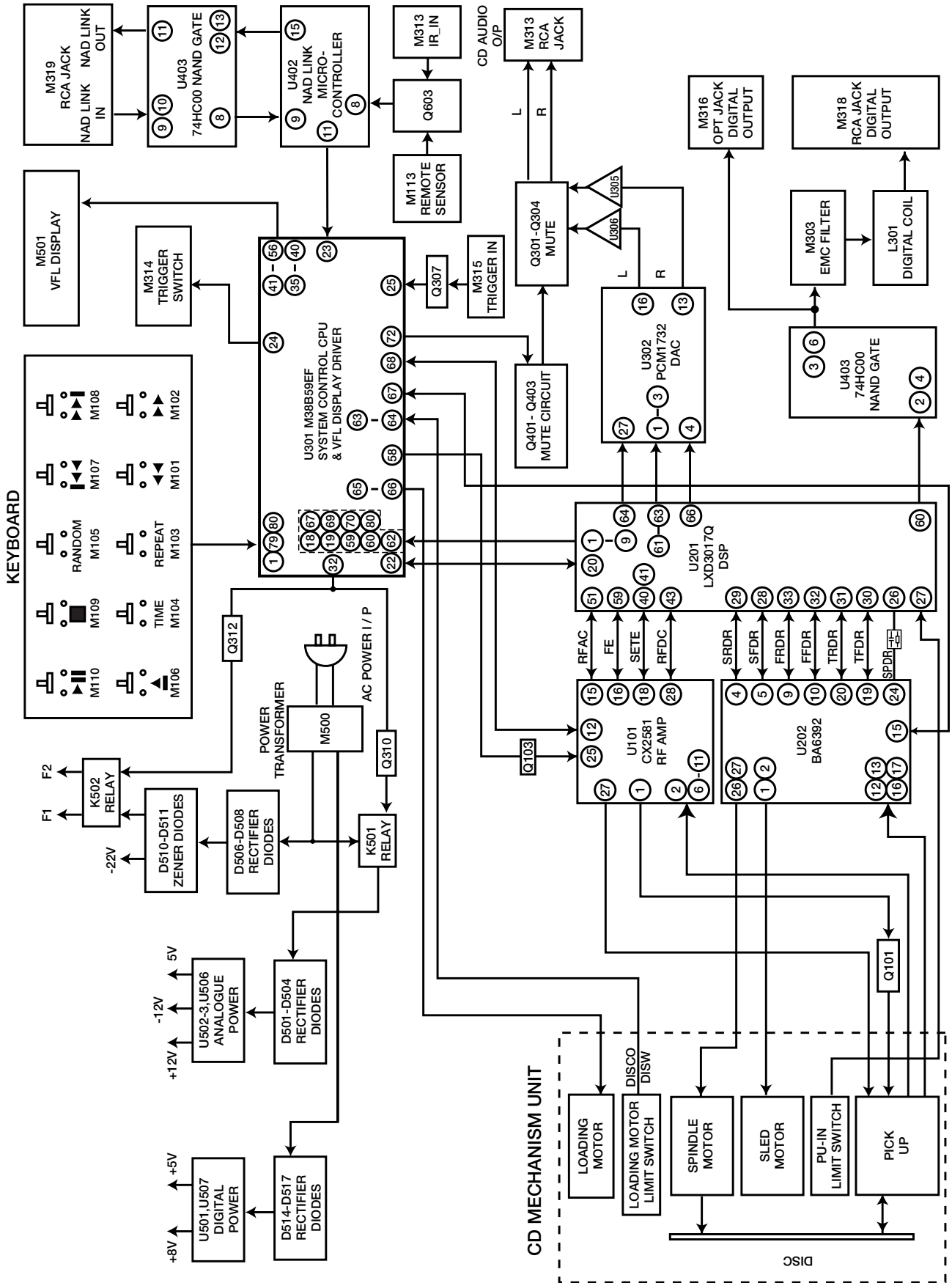
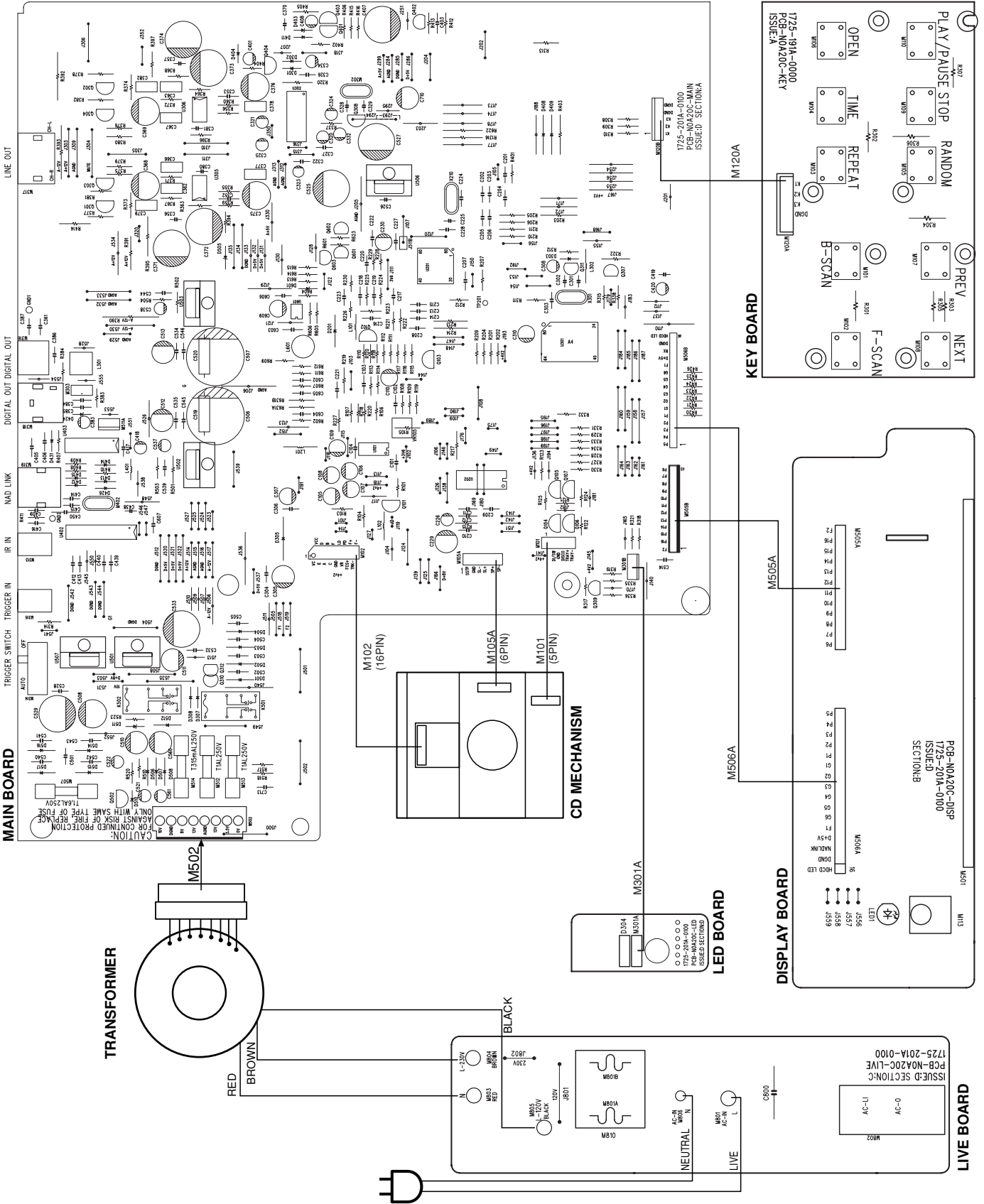

Figure No.2.

# BLOCK DIAGRAM



# WIRING DIAGRAM





# RF PATTERN TESTING

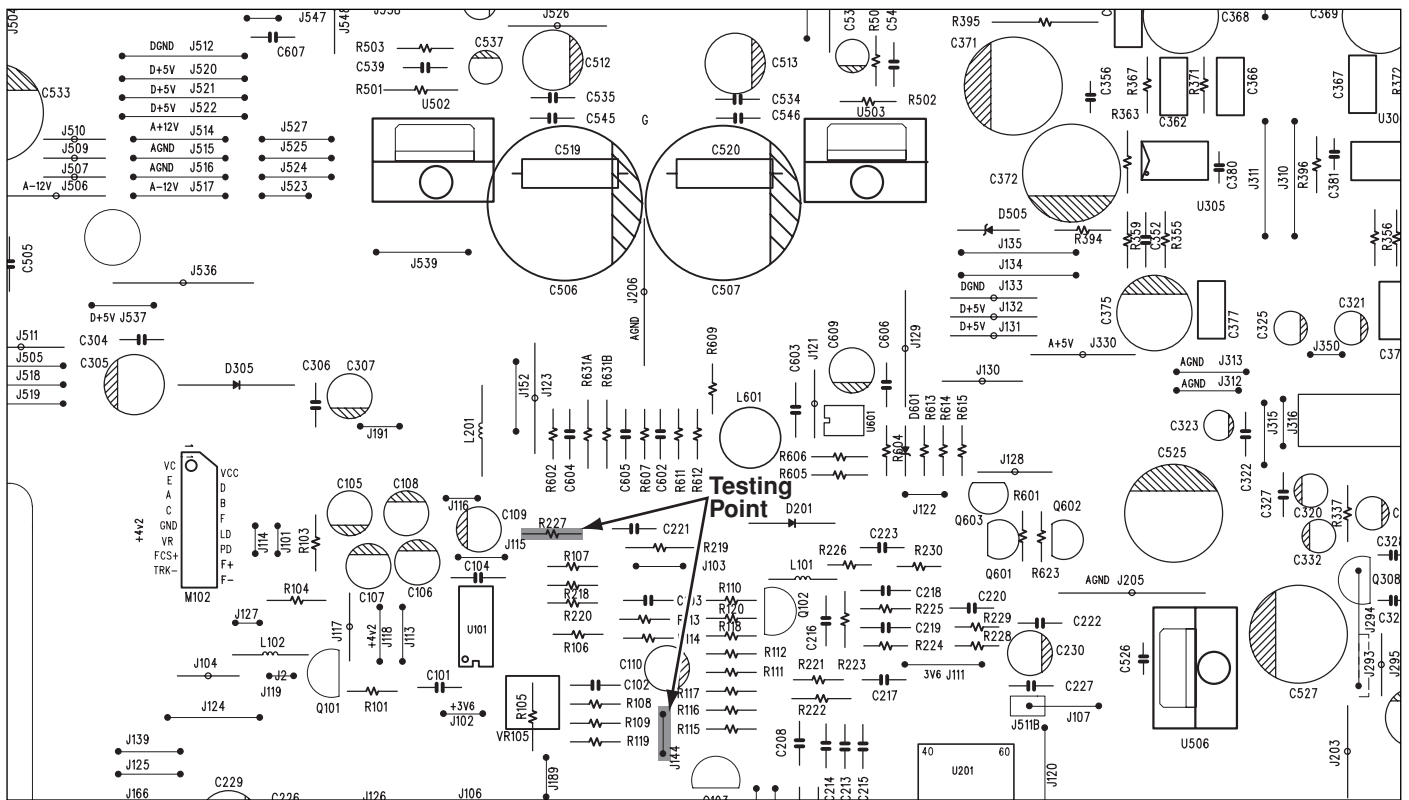

NAD - C 541i PCB TESTING POINTS DIAGRAM

## TESTING PROCEDURE

- (1) Load the test disc (Sony Test CD YEDS-7) and set the unit into PLAY mode.
- (2) Connect the scope to R227 (Pin 15 of U101) and DGND (J144).

Scope setting:

Coupling	: AC.
Vertical sensitivity	: 0.2 V/ div.
Horizontal time base	: 0.5 μS/div.

- (3) Observe the waveform is 2.0V p-p +/-5% and the eye pattern is at its best shape (see FIG. 1).

FIG. 1 (a)

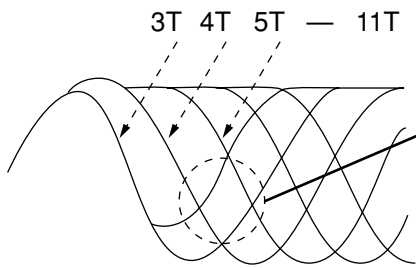

FIG. 1 (b) Poor eye pattern

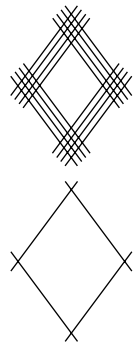

FIG. 1 (c) Good eye pattern



# IMPORTANT NOTES

## INSTRUCTION FOR HANDLING OPTICAL SYSTEM BLOCK PICK-UP

Electrostatic breakdown of the laser diode in the optical system block may occur due to a potential difference caused by electrostatic charge accumulated on clothing, human body, etc. A ground must be provided as follows to prevent any electrostatic charge during unpacking or repair work.

### 1. Ground for Human Body

Be sure to wear a ground band (1M ohm) that is properly to remove any static electricity that may be charged on the body.

### 2. Ground for Work Bench

Be sure to place a conductive sheet (1M ohm) or copper plate with proper grounding on the work bench or other surface on which the pick-up is to be placed.

3. Because the static electricity charge on the clothing does not discharge through the body grounding band, do not let clothing get in contact with the pick-up unit.

### INCORRECT

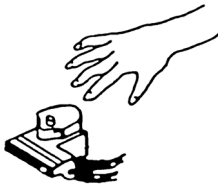

### CORRECT

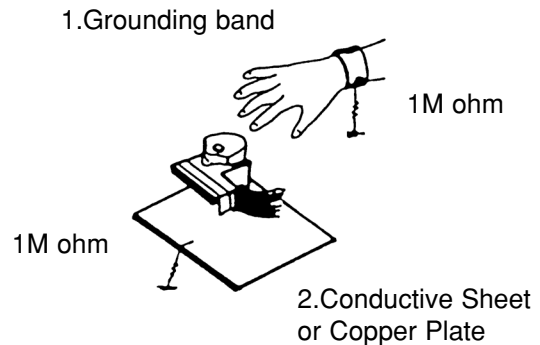

**NOTE:** Laser diodes are so susceptible to damage from static electricity that even if a static discharge does not ruin the diode, it can shorten its life or cause it to work improperly.

## PRECAUTIONS FOR CHECKING BEAM EMISSION

The laser beam of this unit is focused on the reflecting surface of the objective lens in the optical system block. Therefore, keep your eyes at least 12 inches (30 cm) away from the objective lens when the laser diode is **ON**. (Operation Check Method for Laser Diode and Focus Search Function.)

When the **POWER** switch is turned **ON** after the chucking plate is removed, observe the objective lens and confirm that the following operations are performed properly.

(The optical system should be at the lead-in area position when it is checked at this time.)

- (1) The laser should be at the innermost position after the chucking plate is removed.
- (2) The diffused light of the laser beam can be seen when the **POWER** switch is turned **ON**.
- (3) Vertical (up and down) movement of the objective lens (2 or 3 times) will take place.

## PRECAUTIONS WHEN CHANGING LASER PICK-UP

When removing the pick-up assembly, short circuit the PCB tracks on the optical block as show in the drawing in order to protect the pick-up before removal.

**NOTE:** Replacement pick-up assemblies are supplied with the PCB pattern already protected.

DO NOT REMOVE THE SHORT CIRCUITS UNTIL YOU HAVE FINISHED FITTING THE PICK-UP.

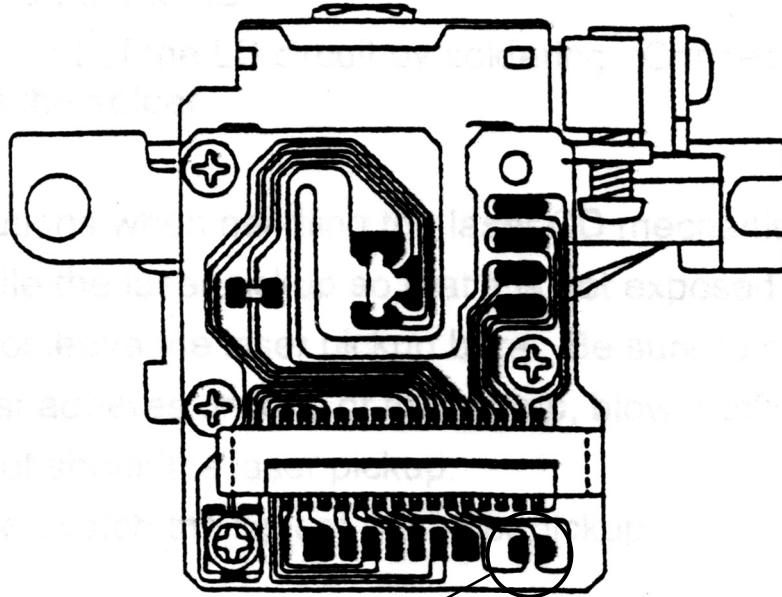

Protective soldering place  
for laser diode

### Caution:

Laser diodes are extremely susceptible to damage from static electricity. Even if a static discharge does not ruin the diode, it can shorten its life or cause it to work improperly. When replacing the pick-up, use a conductive mat, a grounded soldering iron, and so on, to protect the laser diode from static damage.

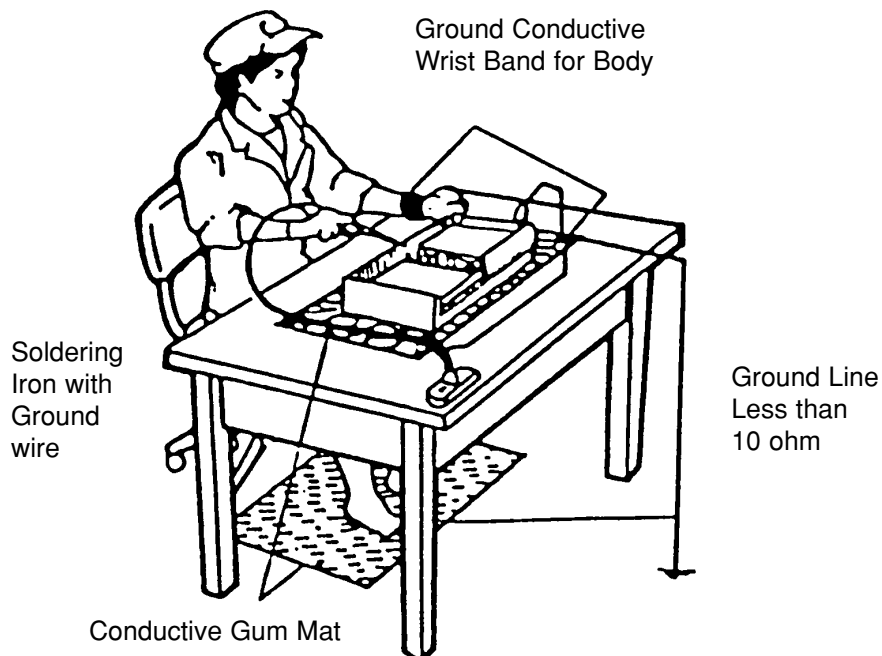

# PCB LAYOUT

## DISPLAY BOARD

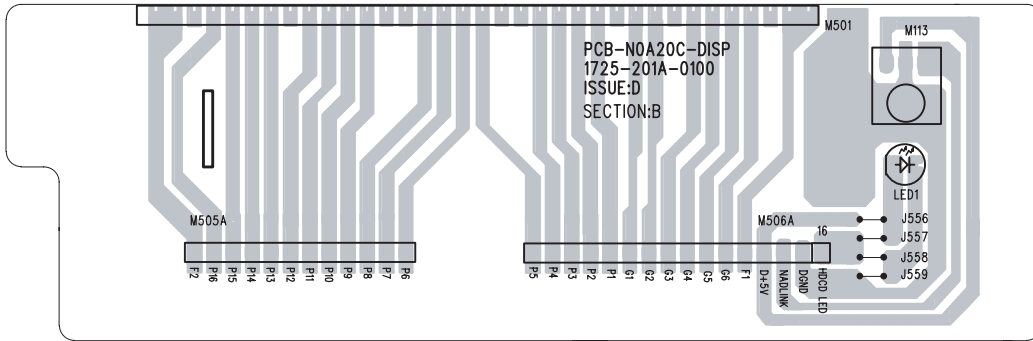

## KEY BOARD

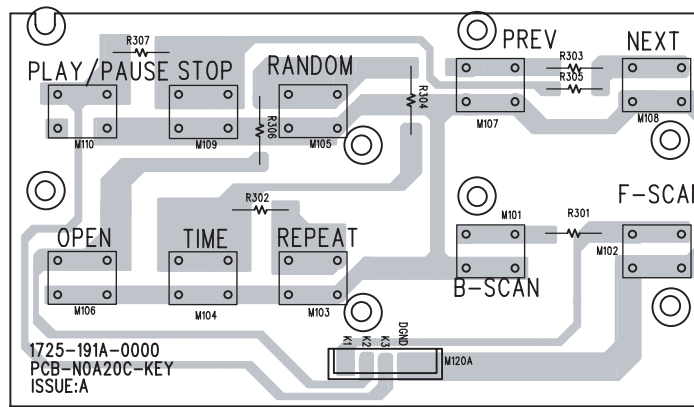

## LIVE BOARD

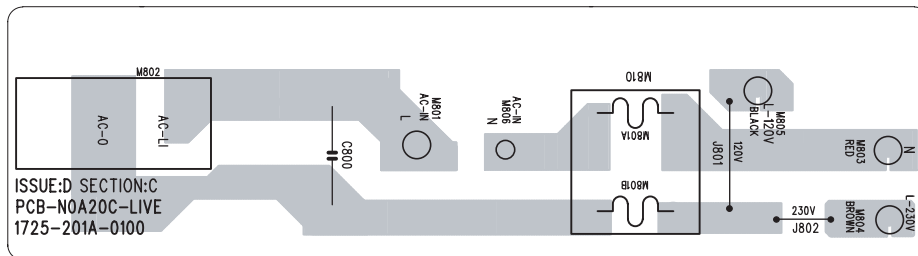

## LED BOARD

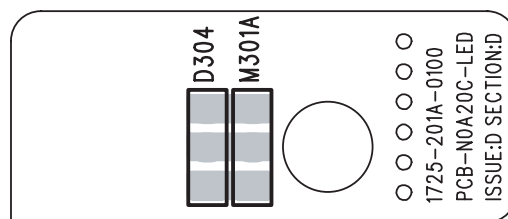

MAIN BOARD

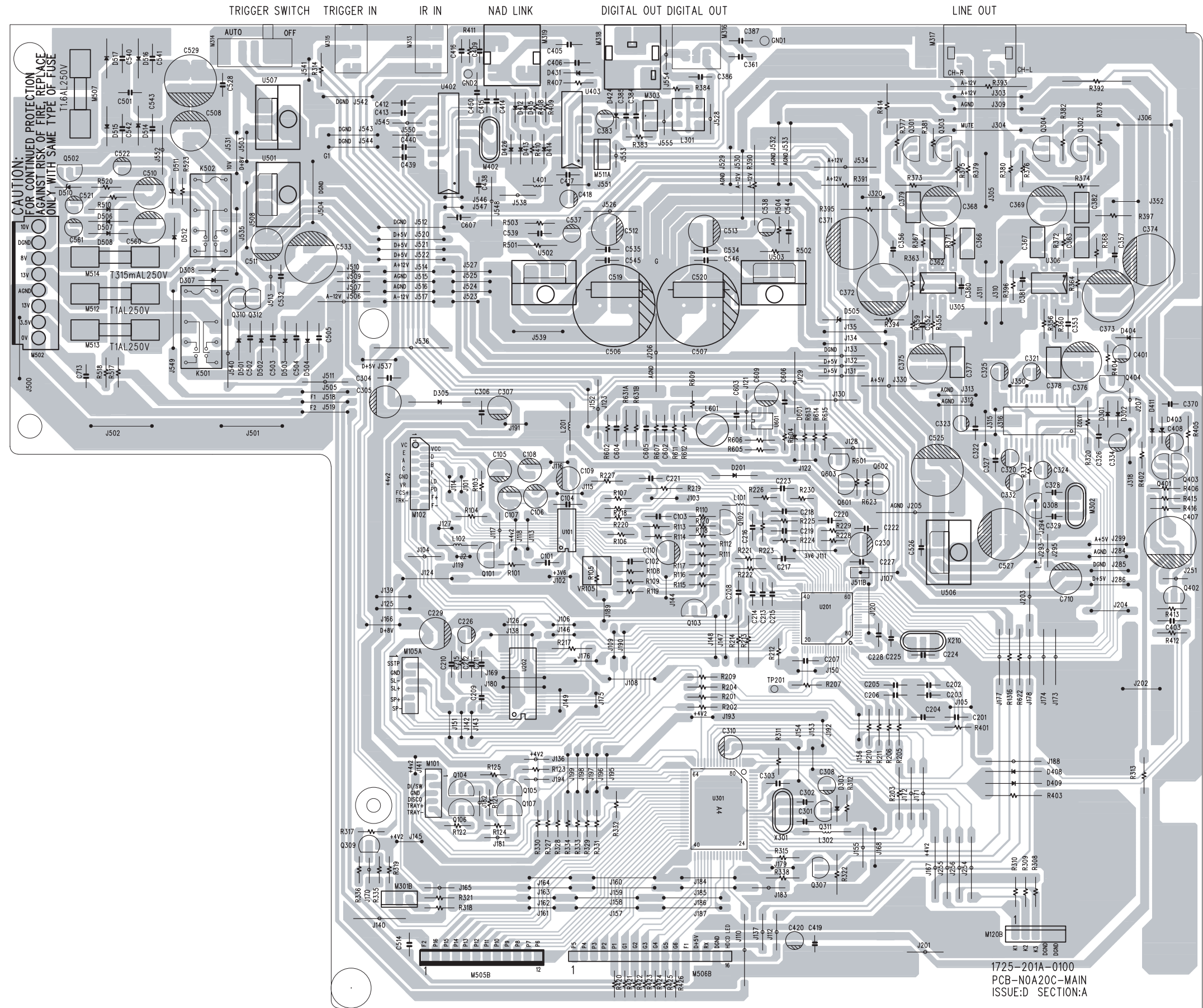

# SCHEMATIC DIAGRAM

MCU

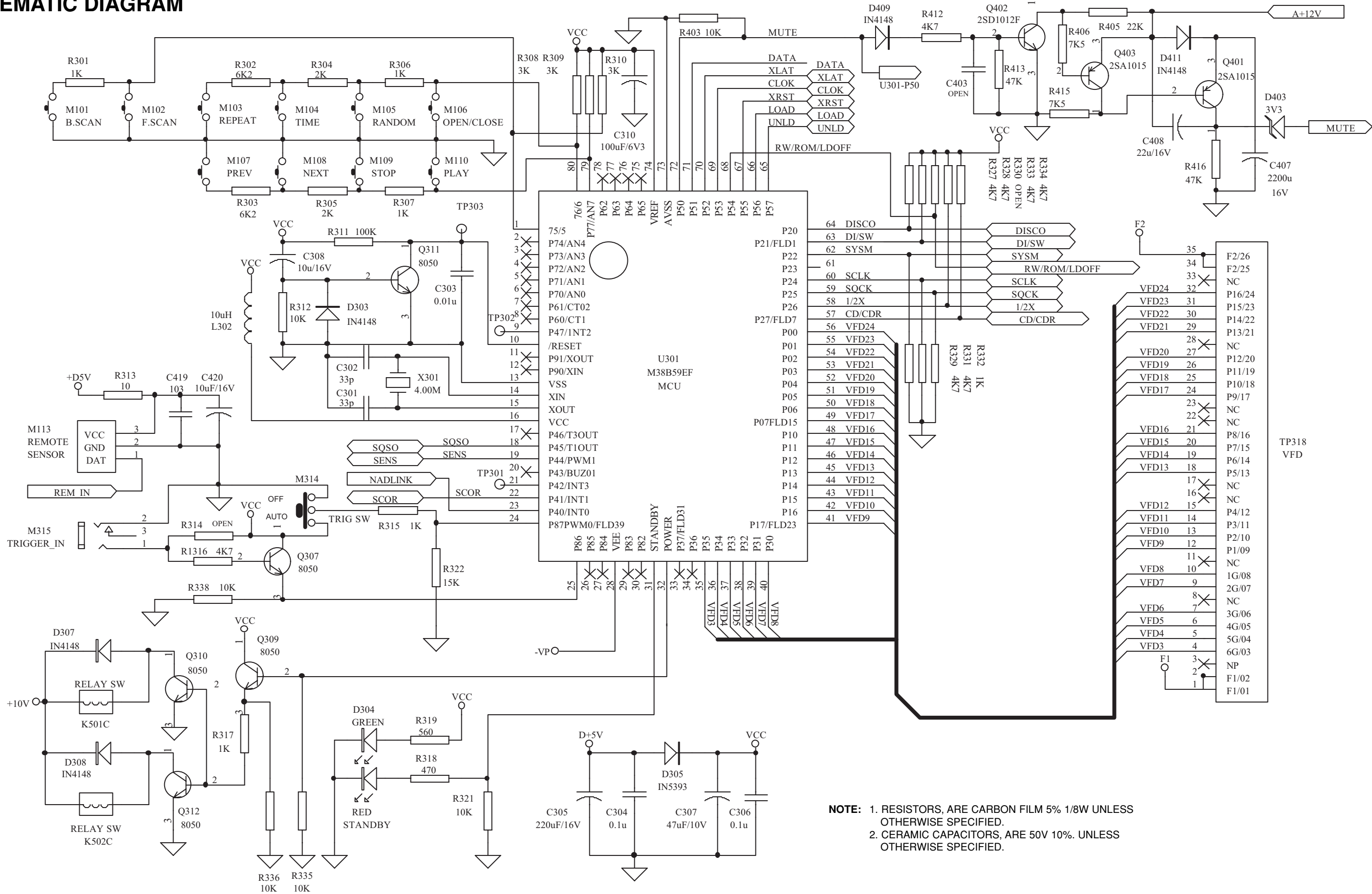

**NOTE:** 1. RESISTORS, ARE CARBON FILM 5% 1/8W UNLESS OTHERWISE SPECIFIED.  
2. CERAMIC CAPACITORS, ARE 50V 10%. UNLESS OTHERWISE SPECIFIED.



# DISPLAY

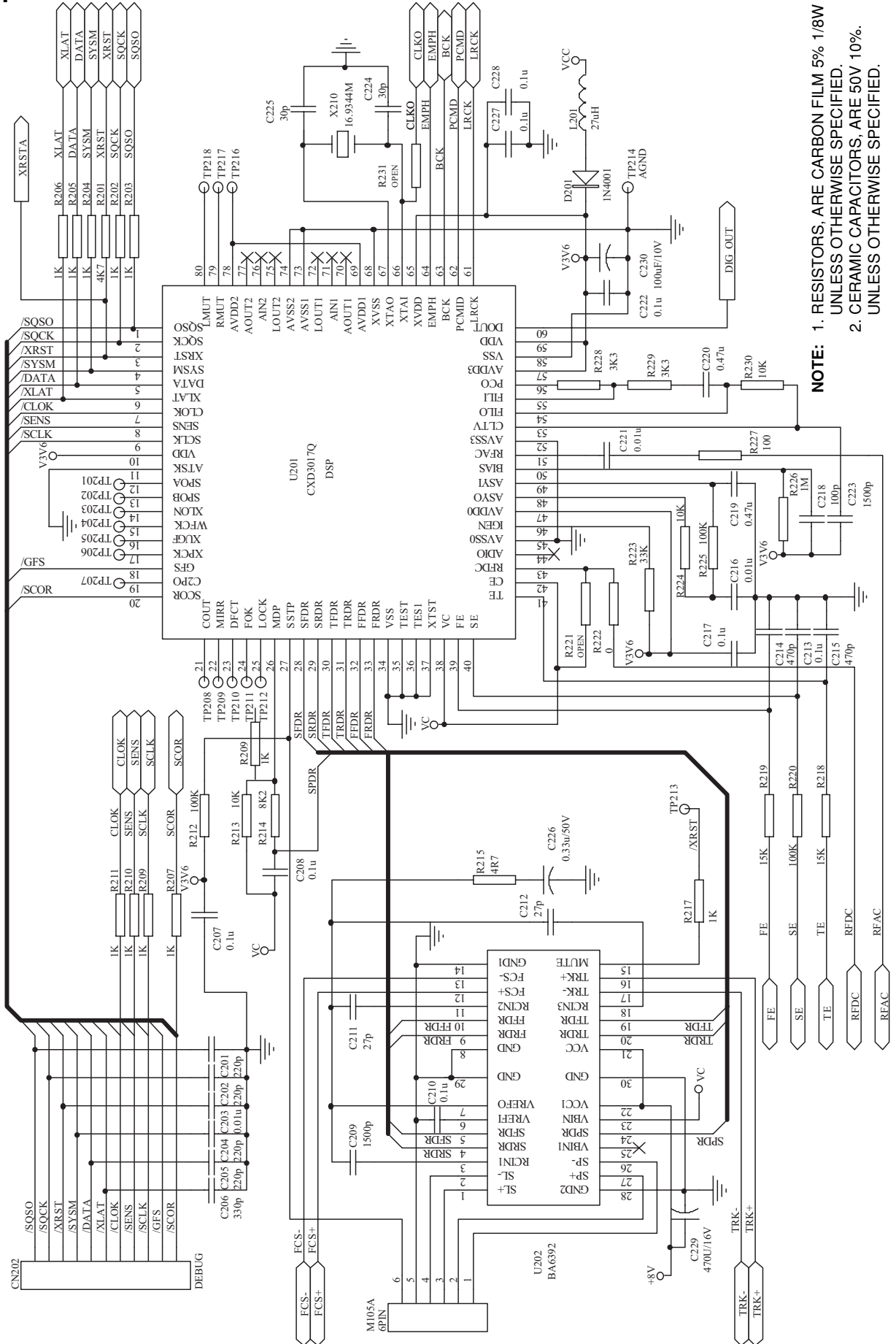

- NOTE:**
1. RESISTORS ARE CARBON FILM 5% 1/8W UNLESS OTHERWISE SPECIFIED.
  2. CERAMIC CAPACITORS ARE 50V 10% UNLESS OTHERWISE SPECIFIED.

# RF AMP

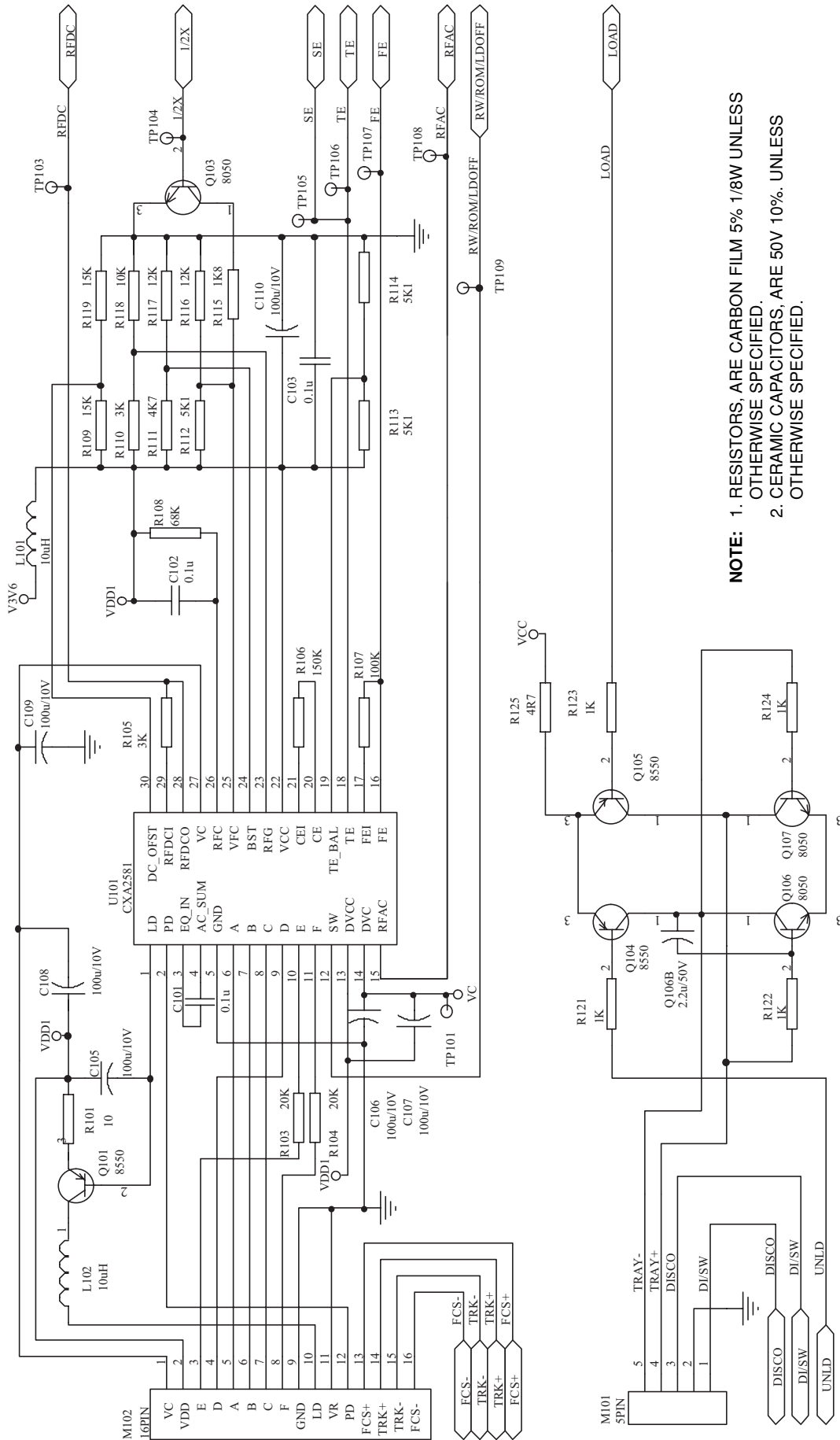

**NOTE:** 1. RESISTORS, ARE CARBON FILM 5% 1/8W UNLESS OTHERWISE SPECIFIED.  
 2. CERAMIC CAPACITORS, ARE 50V 10%. UNLESS OTHERWISE SPECIFIED.



# AMP

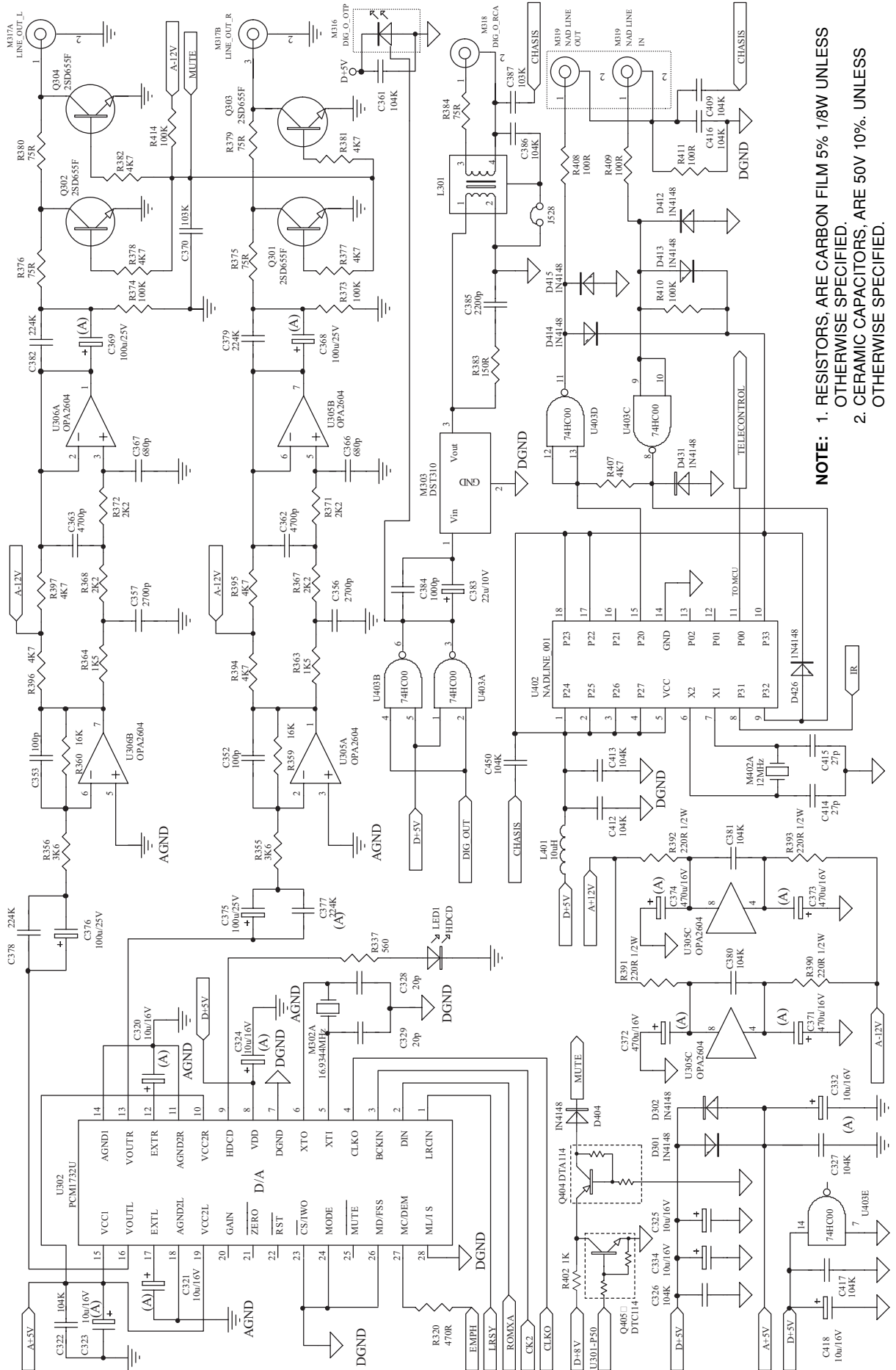

**NOTE:** 1. RESISTORS, ARE CARBON FILM 5% 1/8W UNLESS OTHERWISE SPECIFIED.  
 2. CERAMIC CAPACITORS, ARE 50V 10%. UNLESS OTHERWISE SPECIFIED.

# POWER

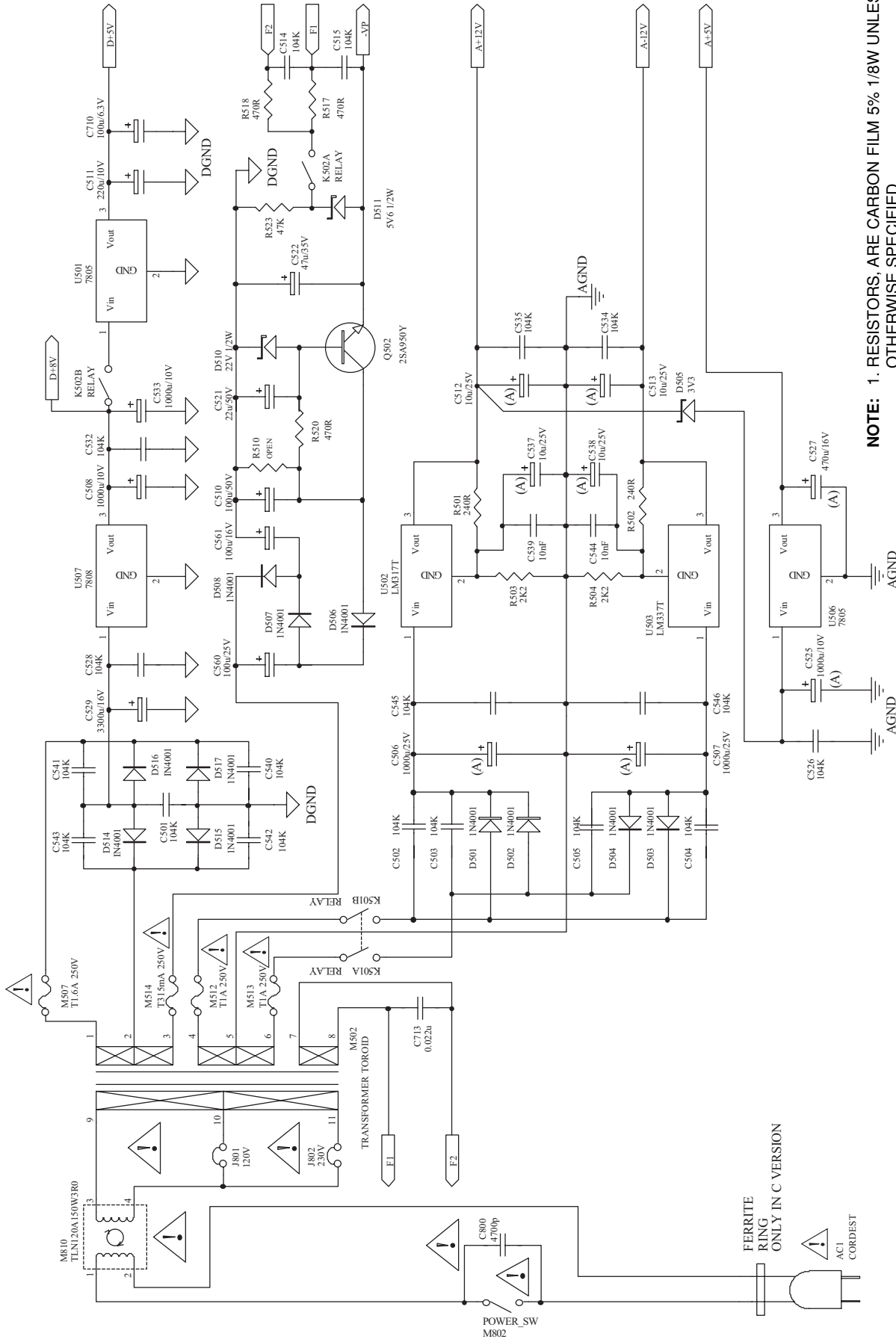

**NOTE:** 1. RESISTORS, ARE CARBON FILM 5% 1/8W UNLESS OTHERWISE SPECIFIED.  
 2. CERAMIC CAPACITORS, ARE 50V 10%. UNLESS OTHERWISE SPECIFIED.

# REMOTE

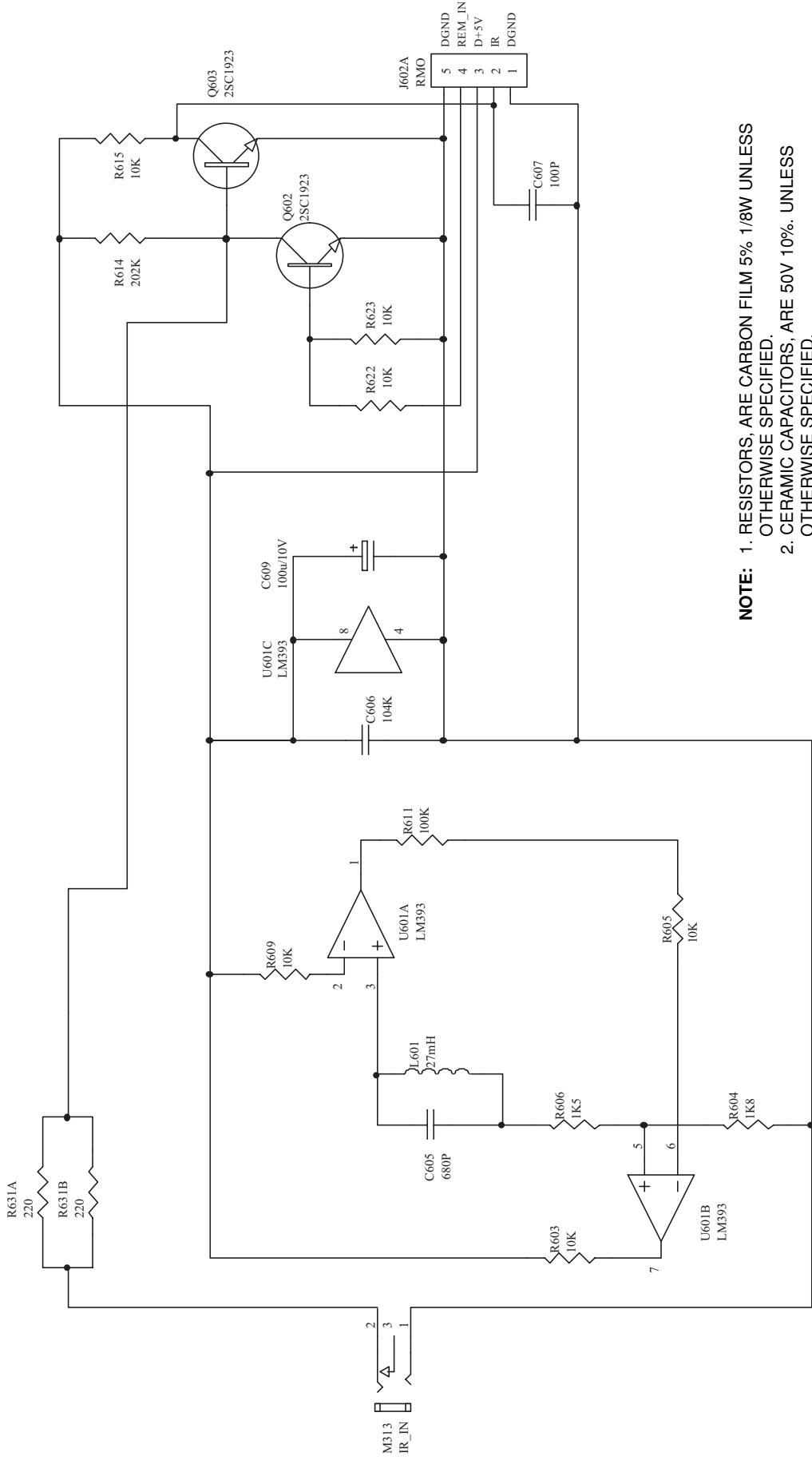

**NOTE:** 1. RESISTORS, ARE CARBON FILM 5% 1/8W UNLESS OTHERWISE SPECIFIED.  
 2. CERAMIC CAPACITORS, ARE 50V 10%. UNLESS OTHERWISE SPECIFIED.

# IC BLOCK DIAGRAM

## MAIN BOARD

U101: CXA2581N

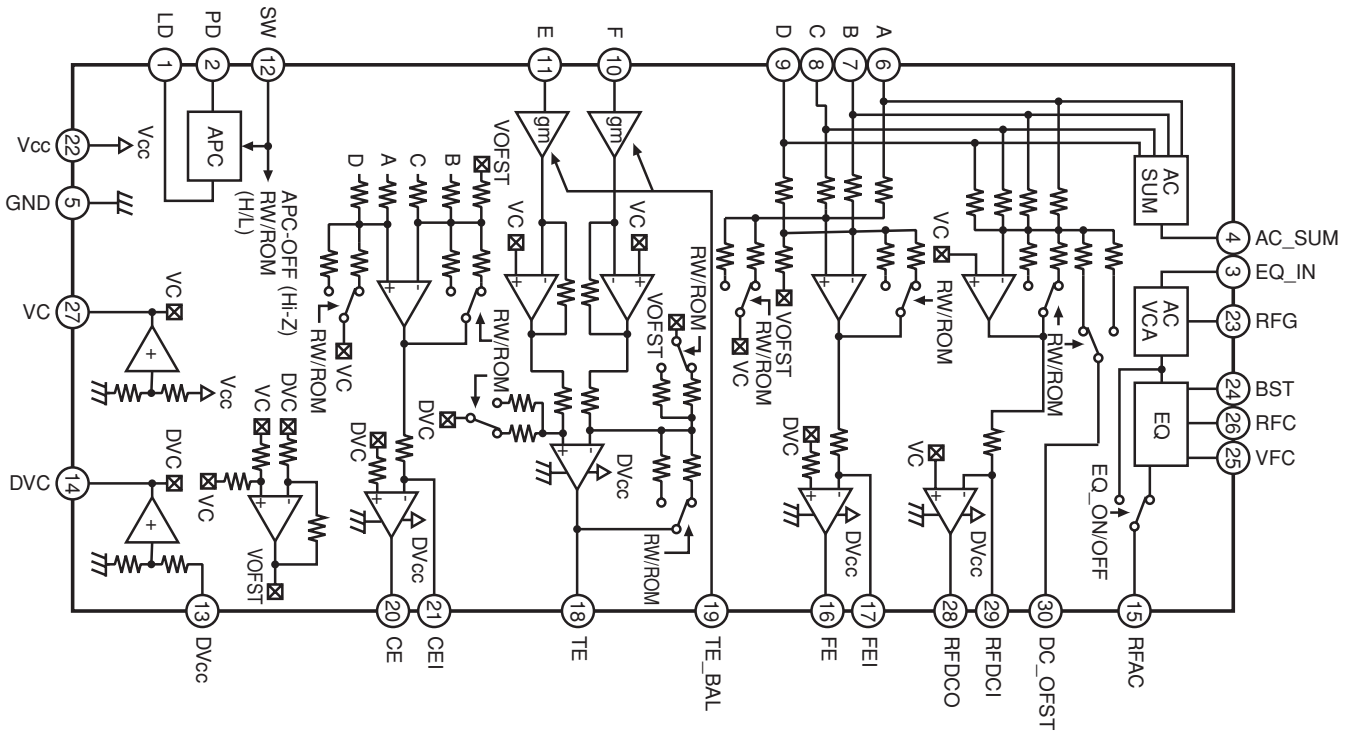

## MAIN BOARD

U202: BA6392FP

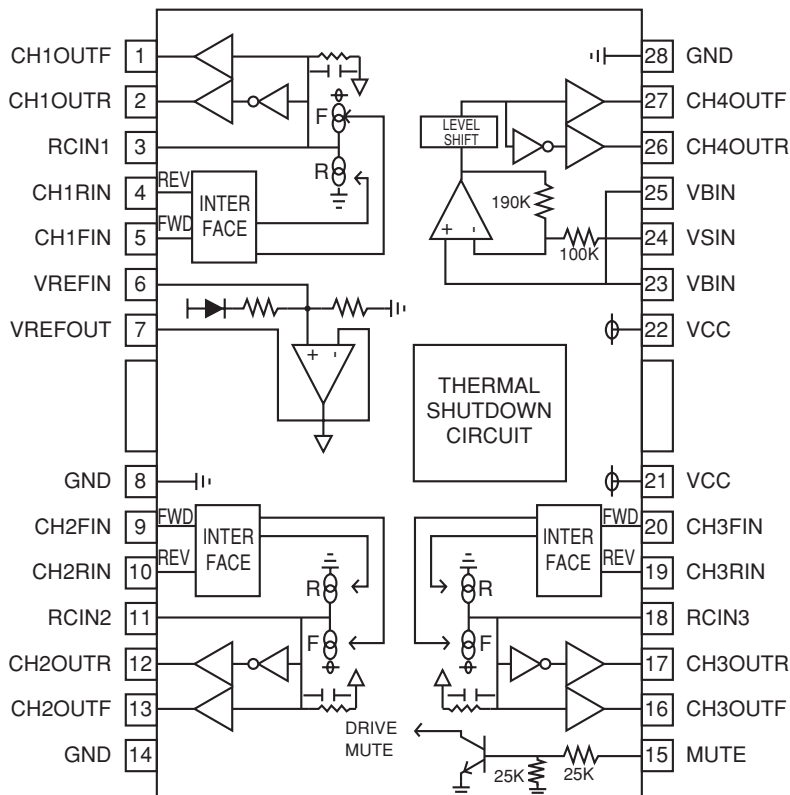

**MAIN BOARD**  
**U201: CXD3017Q**

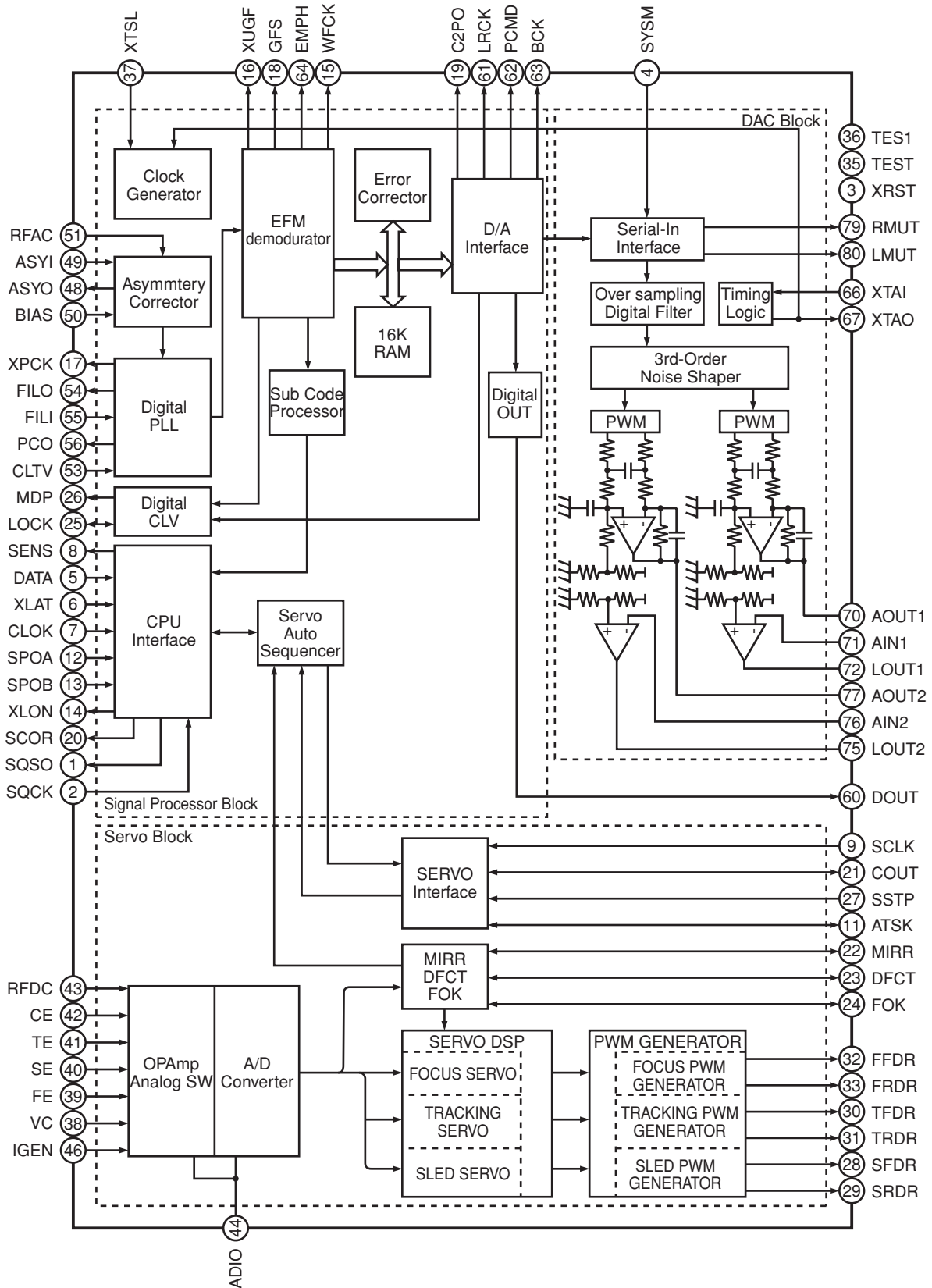

# MAIN BOARD

## U301: M38B59EF

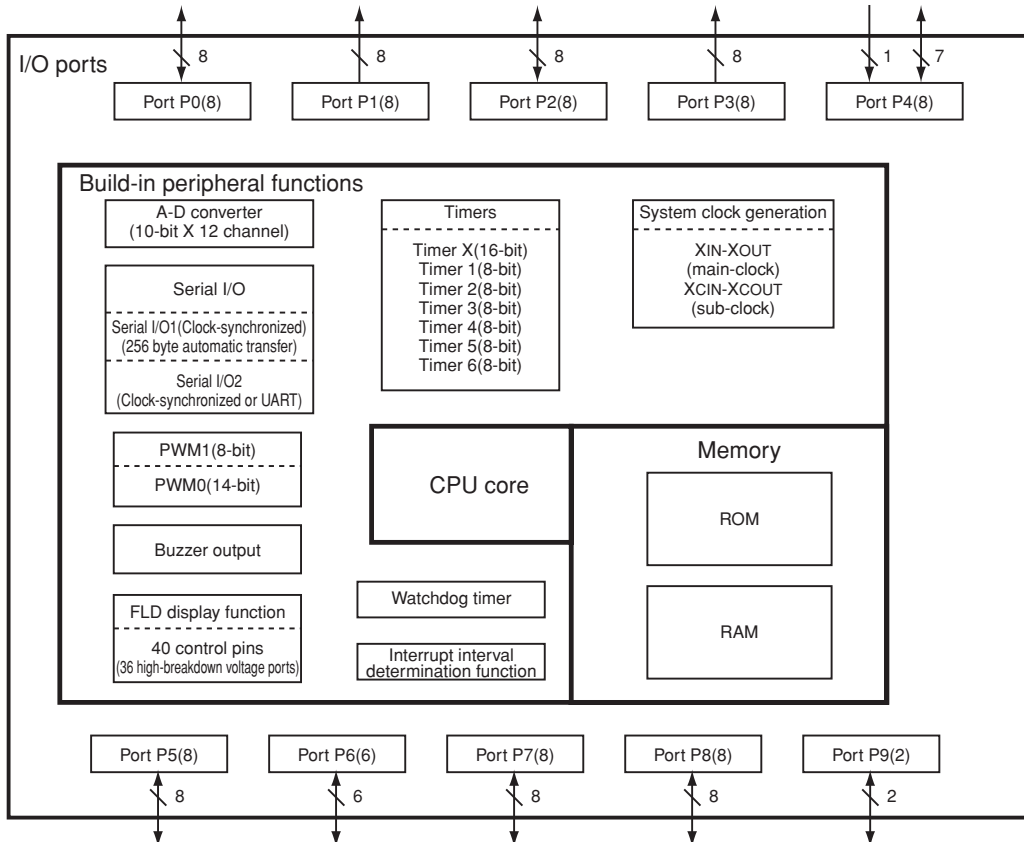
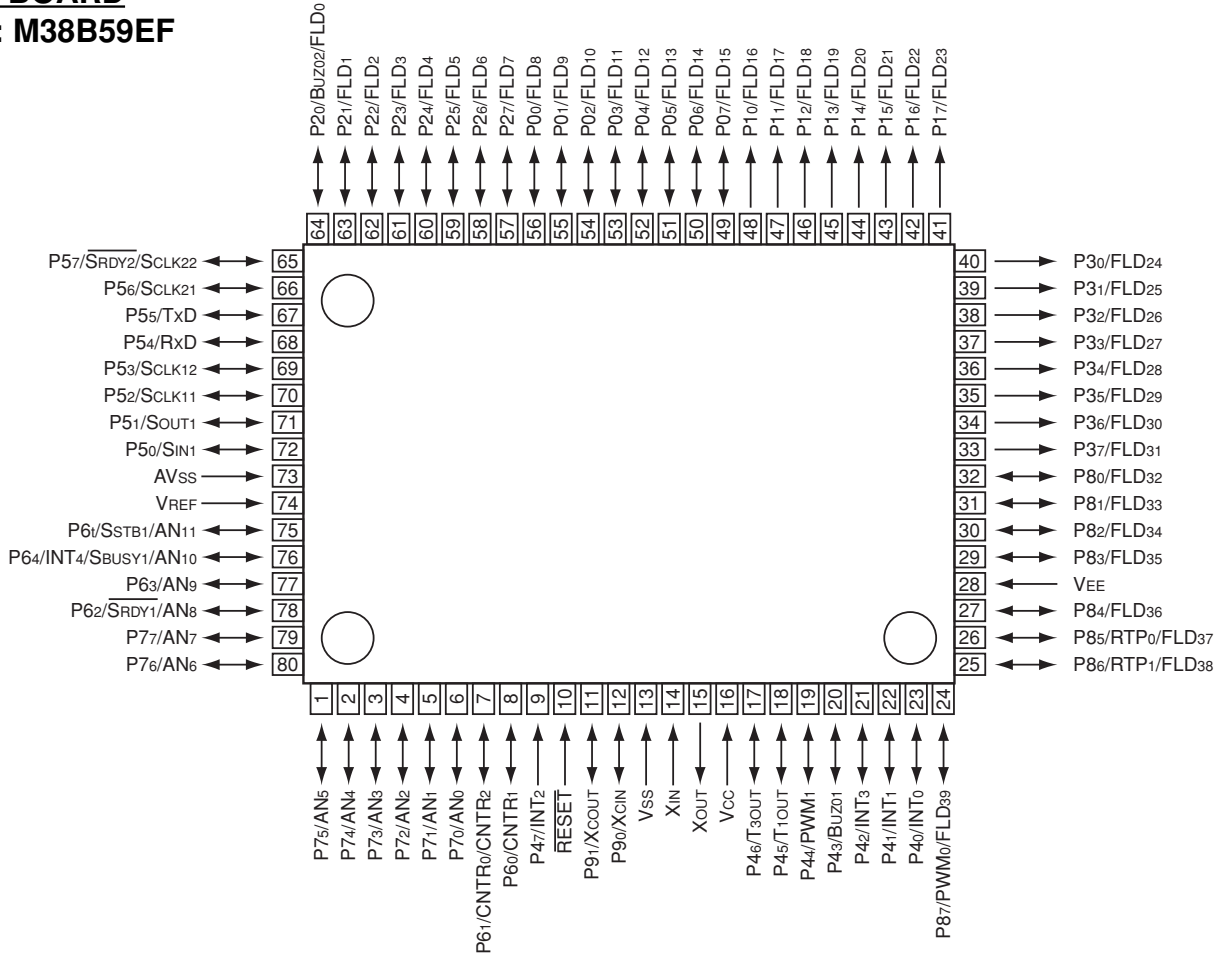

**MAIN BOARD**  
**U302: PCM1732**

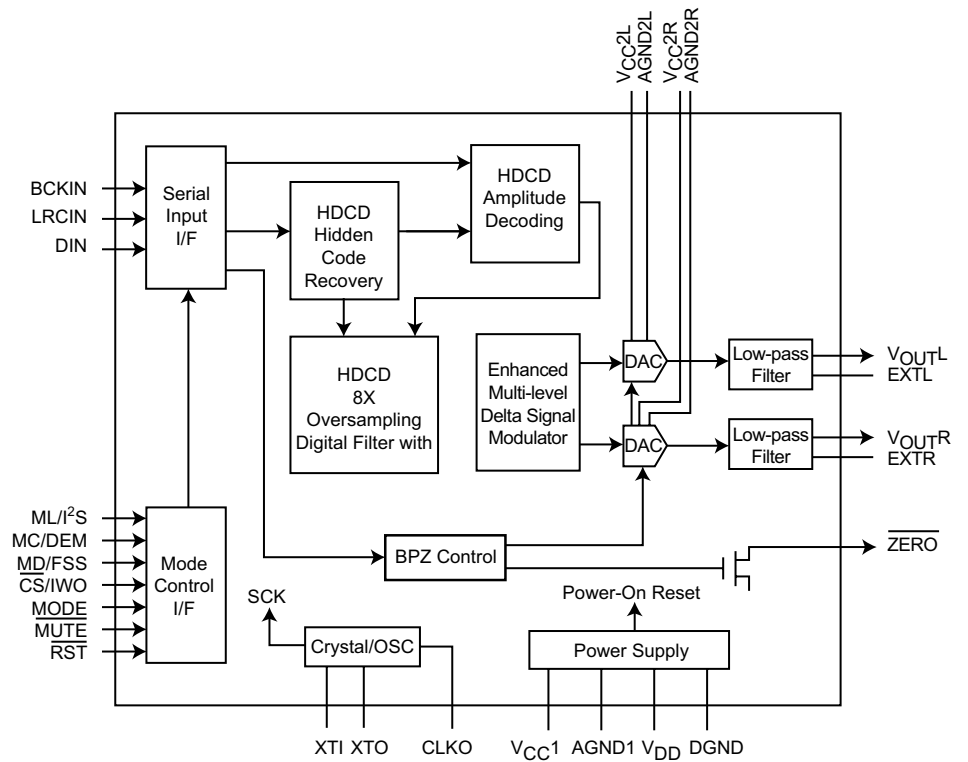
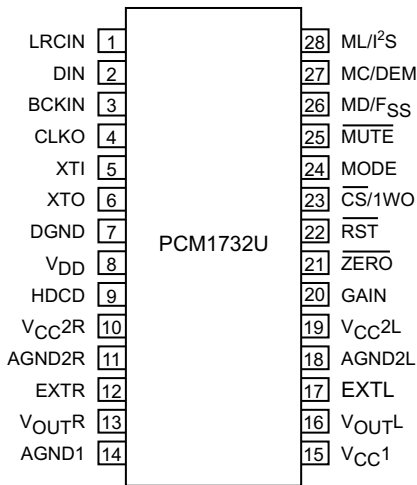

**MAIN BOARD**  
**U402: NADLINK (MASKED)**

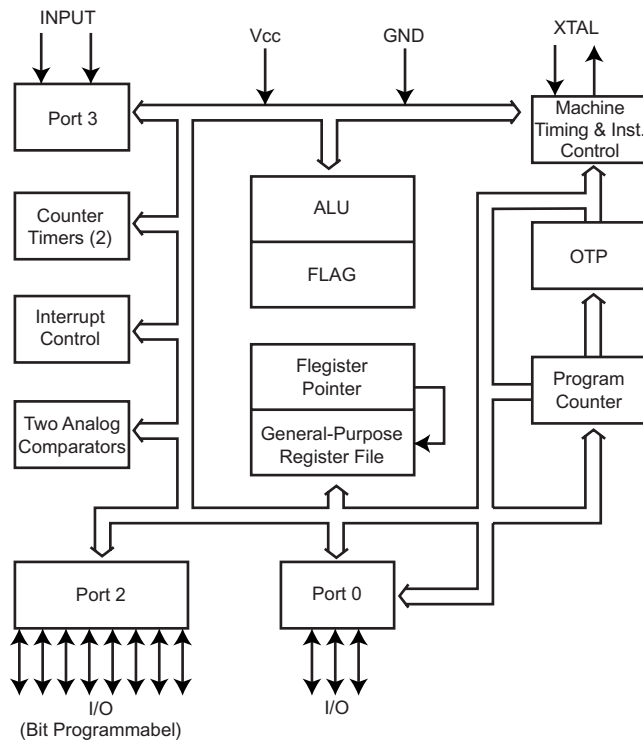
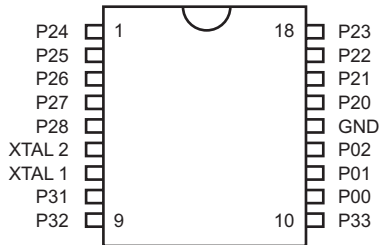

**MAIN BOARD**

**U305, U306: OPA2604**

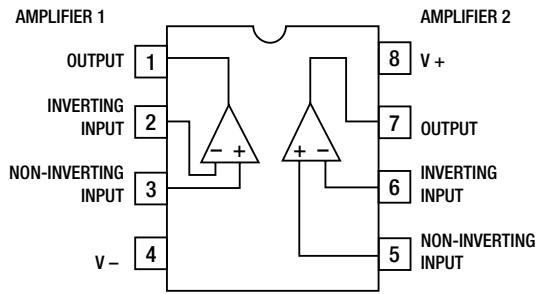

**MAIN BOARD**

**U403: TC74HC00AP**

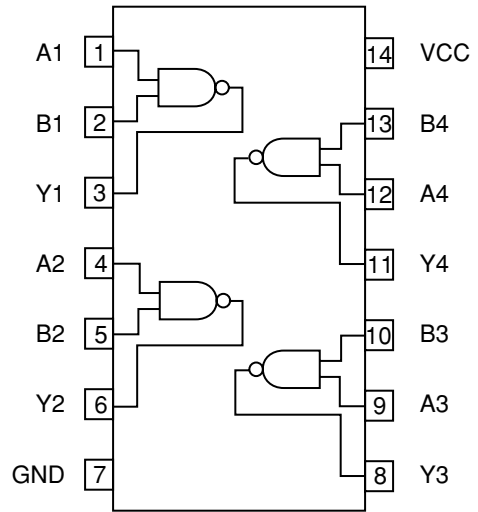

**MAIN BOARD**

**U501, U506, U507: 78XX**

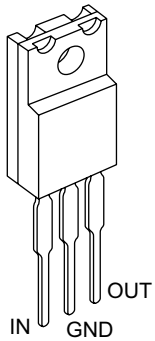

**MAIN BOARD**

**U601: LM393D**

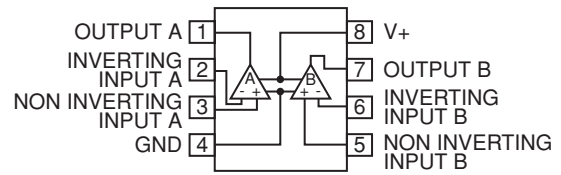



# TROUBLESHOOTING GUIDE

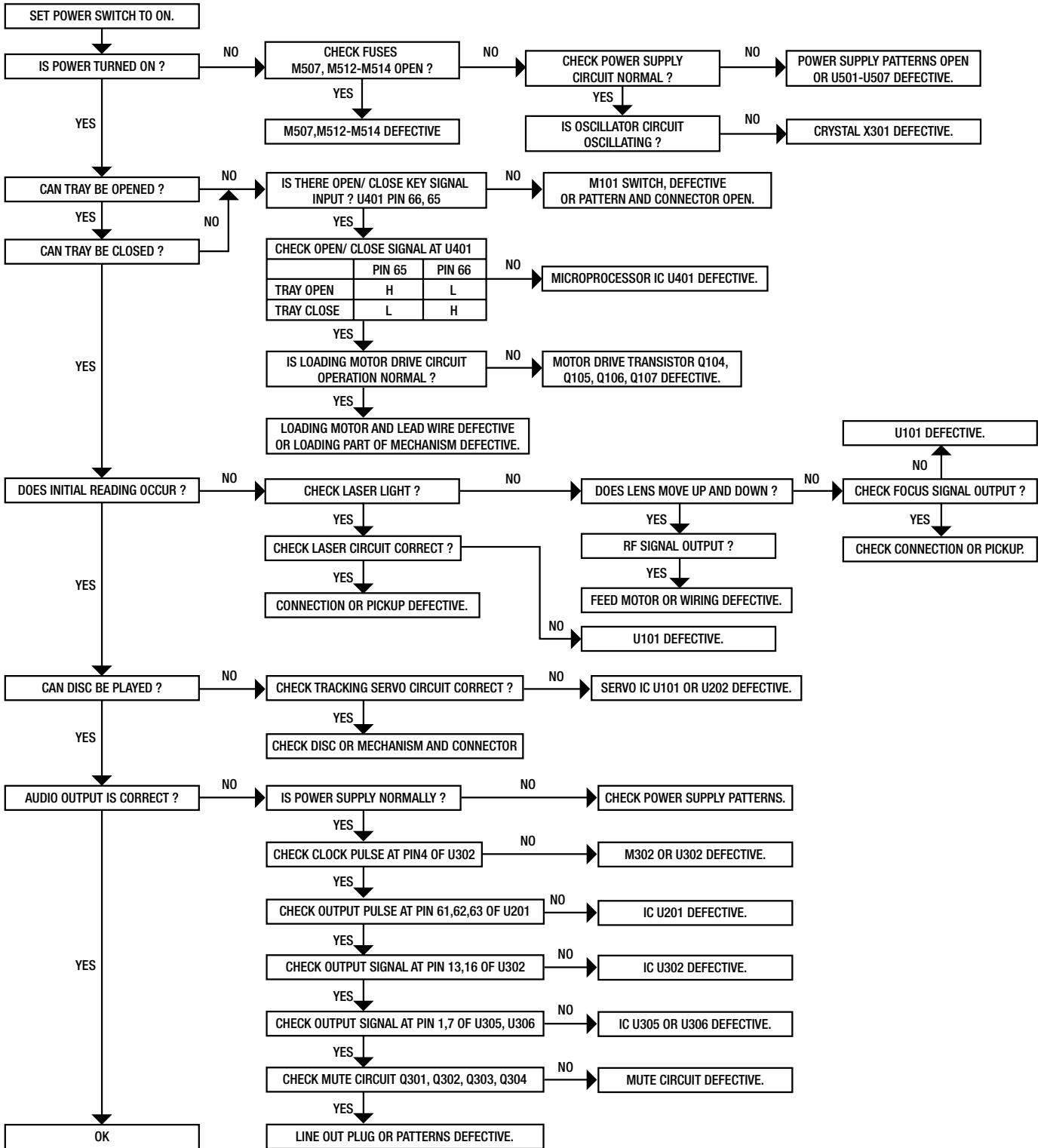

# ELECTRICAL PARTS LIST

<u>Reference No.</u>	<u>Part No.</u>	<u>Description</u>
<b><u>DISPLAY ASSEMBLY</u></b> <b><u>PCB BOARD</u></b> 1000 *	PCB-N0A20C-DISP	DISPLAY ASSEMBLY
<b><u>VFD</u></b> M501	2460-1870-0	VFD 6-BT-271GK
<b><u>LED</u></b> LED1	3700-2810-R	LED RED 3MM SP L-93XHD
<b><u>IR SENSOR</u></b> M113	4816-043T-3	IR SENSOR PIC-26043TM2
<b><u>CONNECTOR WIRES</u></b> M505A M506A	7009-9620-0 7010-2224-0	CONN WIRE ASSY 12P 100MM CONN WIRE ASSY AWG28
<b><u>KEYBOARD ASSEMBLY</u></b> <b><u>PCB BOARD</u></b> 2000 *	PCB-N0A20C-KEY	KEYBOARD ASSEMBLY
<b><u>CONNECTOR WIRE</u></b> M120A	7705-1120-2004	CONN.ASSY 5P P2.5 L=120
<b><u>SWITCHES</u></b> M101-M110	5200-3538-0	SWITCH, TACT SKHHBY 7MM
<b><u>RESISTORS</u></b> R301,R306,R307 R302,R303 R304,R305	4701-102J-C 4701-622J-C 4701-202J-C	RCF 1/8W 1K 5% ATS RCF 1/8W 6.2K 5% ATS RCF 1/8W 2K 5% ATS
<b><u>LED BOARD</u></b> <b><u>PCB BOARD</u></b> 5000 *	PCB-N0A20C-LED	LED ASSEMBLY
<b><u>LED</u></b> D304	3700-3517-RG	LED RED/GREEN (L-469HGW)
<b><u>CONNECTOR WIRE</u></b> M301A	7703-1280-2004	CONN.ASSY 3P P2.5 L=280
<b><u>LIVE ASSEMBLY</u></b> <b><u>PCB BOARD</u></b> 3000 *AH 3000 *C	PCB-N0A20C-LIVE PCB-N0A21C-LIVE	LIVE ASSEMBLY LIVE ASSEMBLY

<b>Reference No.</b>	<b>Part No.</b>	<b>Description</b>
<b>CAPACITOR</b> C800   △	8910-0049-0	CAP400V 4700P DE7150F472MVA1KC
<b>POWER SWITCH</b> M802   △	5200-3151-0-01	POWER SWITCH
<b>TRANSFORMER</b> M810   *C   △	1806-2170-0	EMI FILTER TLN12UA 150W3R0
<b>TRANSFORMER ASSEMBLY</b> <b>TRANSFORMER</b> M500   △	1806-2512-0	TRANSFORMER N0870C I/P 120/230V TOROIDAL
<b>FUSE ASSEMBLY</b> <b>FUSES</b>		
M507           *AH   △	5120-0052-0	FUSE T1.6A 250V 5x20MM UL/CSA
M507           *C   △	5120-0050-0	FUSE T1.6A 250V 5x20MM SEMKO/VDE
M512, M513   *AH   △	5120-0020-0	FU T1A 250V 5x20MM UL/CSA
M512, M513   *C   △	5120-0018-0	FU T1A 250V 5x20MM SEMKO/VDE
M514           *AH   △	5120-0026-0	FU T315MA L 250V 5x20MM UL/CSA
M514           *C   △	5120-0027-0	FU T315MA L 250V 5x20MM SEMKO/VDE
<b>MAIN ASSEMBLY</b> <b>PCB BOARD</b> 4000 *	PCB-N0A20C-MAIN	MAIN ASSEMBLY
<b>CAPACITORS</b>		
C101	150F-104K-5-II	CC 50V 0.1µF 10% RL 5x5
C102,C103	150F-104K-2-FC	CC 50V 0.1µF 10% AT 3.5x2
C105-C110	157C-107M-5-IUE	CE 10V 100µF 20% RL 5X11
C111	157F-225M-5-IUNK	CE 50V 2.2µF 20% RL 5X11 NP
C201,C204	150F-221K-2-FC	CC 50V 220pF 10% AT 3.5x2
C203,C216,C221	150F-103K-2-FC	CC 50V 0.01µF 10% AT 3.5x2
C206	150F-331K-2-FC	CC 50V 330pF 10% AT 3.5x2
C207,C208,C210,C213	150F-104K-2-FC	CC 50V 0.1µF 10% AT 3.5x2
C209,C223	153F-152J-5-JM	CM 50V 1500PF 5% RL 5.5x7
C211,C212	15CH-270J-5-GG	CTC 0/60 27pF 5% RL 4x4
C214,C215	150F-471K-2-FC	CC 50V 470pF 10% AT 3.5x2
C217,C222,C227,C228	150F-104K-2-FC	CC 50V 0.1µF 10% AT 3.5x2
C218	150F-101K-2-FC	CC 50V 100pF 10% AT 3.5x2
C219,C220	150F-474M-5-II	CC 50V 0.47µF 20% RL 5X5
C226	157F-334M-5-GMK	CE 50V 0.33µF 20% RL 4x7
C229	157D-477M-5-OVK	CE 16V 470µF 20% RL 8x11.5
C230	157C-107M-5-IUE	CE 10V 100µF 20% RL 5X11
C303,C370	153F-103J-5-IM	CM 50V 0.01µF 5% RL 5X7
C304	150F-104K-2-FC	CC 50V 0.1µF 10% AT 3.5x2
C305	157D-227M-5-OMK	CE 16V 220µF 20% RL 8x7
C306,C326,C327,C361,C380,C381	150F-104K-5-II	CC 50V 0.1µF 10% RL 5x5
C307	157C-476M-5-IMK	CE 10V 47µF 20% RL 5X7

<b>Reference No.</b>	<b>Part No.</b>	<b>Description</b>
C308,C325,C334	157D-106M-5-GMK	CE 16V 10μF 20% RL 4x7
C310	157B-107M-5-KMK	CE 6.3V 100μF 20% RL 6x7
C320,C321,C323,C324,C332	157D-106M-5-IUF3	CE 16V 10μF 20% RL 5X11 ROA ELNA
C322,C386	150F-104K-2-FC	CC 50V 0.1μF 10% AT 3.5x2
C328,C329	15CH-200J-5-GG	CTC 0/60 20pF 5% RL 4x4
C352,C353	150F-101J-5-IF	CC 50V 100pF 5% RL 5x3.5
C356,C357	153F-272J-5-JM	CM 50V 2700PF 5% RL 5.5x7
C362,C363	153I-472K-9-NL	CM 63V 0.0047μF 10% RB 7.5x6.5
C366,C367	158F-681J-5-KW	CP 50V 680pF 5% RL 6x12
C368,C369,C375,C376	157E-107M-5-S5C	CE 25V 100μF 20% RL 10x16
C371-C374	157D-477M-5-X9F3	CE 16V 470μF 20% RL 12.5x20 ROA ELNA
C377-C379,C382	153I-224J-9-NL	CM 63V 0.22μF 5% RB 7.5x6.5
C383	157C-226M-5-IUK	CE 10V 22μF 20% RL 5X11
C384	150F-102K-2-FC	CC 50V 1000pF 10% AT 3.5x2
C385	150F-222K-2-GD	CC 50V 0.0022μF 10% AT
C387	153F-103K-5-IM	CM 50V 0.01μF 10% RL 5x7
C407	157D-228M-5-X9E	CE 16V 2200μF 20% RL 12.5x20
C409,C412,C413,C416	150F-104K-2-FC	CC 50V 0.1μF 10% AT 3.5x2
C414,C415	15CH-270J-5-GG	CTC 0/60 27pF 5% RL 4x4
C417,C450	150F-104K-2-FC	CC 50V 0.1μF 10% AT 3.5x2
C418,C420	157D-106M-5-GMK	CE 16V 10μF 20% RL 4x7
C419	153F-103K-5-IM	CM 50V 0.01μF 10% RL 5x7
C501-C505,C514,C515,C526	150F-104K-5-II	CC 50V 0.1μF 10% RL 5x5
C506,C507	157E-108M-5-5\$F3	CE 25V 1000μF 20% RL 16x31.5 ROA ELNA
C508,C533	157C-108M-5-S5K	CE 10V 1000μF 20% RL 10x16
C510	157F-107M-5-OVK	CE 50V 100μF 20% RL 8x11.5
C511	157C-227M-5-OMK	CE 10V 220μF 20% RL 8x7
C512,C513,C537,C538	157E-106M-5-IUF3	CE 25V 10μF 20% RL 5X11
C521	157F-226M-5-IUK	CE 50V 22μF 20% RL 5X11
C522	157Q-476M-5-LUA	CE 35V 47μF 20% RL 6.5X11
C525	157C-108M-5-X&F3	CE 10V 1000μF 20% RL 12.5x25 ROA ELNA
C527	157D-477M-5-X9F3	CE 16V 470μF 20% RL 12.5x20 ROA ELNA
C528	150F-104K-2-FC	CC 50V 0.1μF 10% AT 3.5x2
C529	157D-338M-5-5&K	CE 16V 3300μF 20% RL 16x25
C532-C535	150F-104K-5-II	CC 50V 0.1μF 10% RL 5x5
C539,C544	153F-103K-5-IM	CM 50V 0.01μF 10% RL 5x7
C540,C541-C543,C545,C546	150F-104K-5-II	CC 50V 0.1μF 10% RL 5x5
C560	157E-107M-5-KUK	CE 25V 100μF 20% RL 6.3x11
C561	157D-107M-5-KUK	CE 16V 100μF 20% RL 6.3x11
C605	150F-681K-2-FC	CC 50V 680pF 10% AT 3.5x2
C606	150F-104K-2-FC	CC 50V 0.1μF 10% AT 3.5x2
C607	153F-102J-5-IM	CM 50V 1000PF 5% RL 5x7
C609	157C-107M-5-IUE	CE 10V 100μF 20% RL 5X11
C710	157B-107M-5-KMK	CE 6.3V 100μF 20% RL 6x7
C713	153F-223K-5-LQ	CM 50V 0.022μF 10% RL 6.5x9
Q106B	157F-225M-5-IUNK	CE 50V 2.2μF 20% RL 5X11
<b>DIODES</b>		
D201	4804-0010-2	DIODE 1N4001 AT
D301-D303,D307,D308	4804-1480-2	DIODE 1N4148 AT

<b>Reference No.</b>	<b>Part No.</b>	<b>Description</b>
D305	4805-3930-2	DIODE 1N5393 200V 1.5A
D403	4837-3V31-2	DZ 1/2W 3.1-3.5V ROHM AT
	4837-3A31-2	DZ 1/2W 3.16~3.38V ROHM
D404	4804-1480-2	DIODE 1N4148 AT
D409,D411-D415,D426,D431	4804-1480-2	DIODE 1N4148 AT
D501-D504,D506-D508	4804-0010-2	DIODE 1N4001 AT
D505	4840-1140-0	ZD 1.3W 3.3V 5% AT
D510	4837-22D1-2	DZ 1/2W 21.52~22.63V
D511	4837-5B61-2	DZ 1/2W 5.45-5.73 ROHM
D514-D517	4804-0010-2	DIODE 1N4001 AT
<b>RELAYS</b>		
K501,K502	4500-0200-1	RELAY 2P2T BT-12S 12VDC
<b>COILS</b>		
L101,L102	1801-100K-M	COIL 10 $\mu$ H 10% BL7.0
L201	1801-270K-M	COIL 27 $\mu$ H,10%,AL,BL7.0
L301	1802-0450-0	DIGITAL COIL
L302	1801-100K-M	COIL 10 $\mu$ H 10% BL7.0
L601	1807-273J-PS	COIL 27MH 5% 8.3X9.7
<b>WAFERS / CONNECTORS</b>		
M102	2101-1382-0	CONNECTOR FLEXIBLE 16P P=1MM
M120B	2102-051S-004	5P ST.WAFER P=2.5
M301B	2102-031S-004	3 PIN ST. WAFER P=2.5
M502	2101-1811-0	8P PIN CONNECTOR P=3.96
M505B	2102-121S-004	12P ST.WAFER P=2.5
M506B	2102-161S-004	16P ST WAFER P=2.5
<b>CRYSTALS</b>		
M302	2300-1910-0	X'TAL 16.9344MHZ
M303	2704-0060-0	EMC FILTER
M402	2703-0190-0	CR 12.0MHZ, CSALA12MOT55-BO
X301	2703-0150-1	CR4.00MHE,CSTLS4M00G55-B
<b>JACKS</b>		
M313,M315	2113-1743-0	MONO JACK HTJ-035-12E
M317	2113-1300-0	2P RCA JACK W/R AU
M318	2113-1170-0	1P RCA JACK YL AU
M319	2113-1121-0	2P RCA JACK Y/Y AU
<b>SWITCH</b>		
M314	5200-3171-0-01	DPDT SLIDE
<b>TRANSISTORS</b>		
M316	4811-F32T-3	LIGHT TX UNIT GP1F32T
Q101,Q104,Q105	4860-0060-5	TR SS8550 C/D SAMSUNG RL
Q103,Q106,Q107,	4860-0050-5	TR SS8050 C/D SAMSUNG RL
Q301-Q304	4860-1780-5	TR 2SD655F HFE:600-1200
Q307,Q309-Q312	4860-0050-5	TR SS8050 C/D SAMSUNG RL

<b>Reference No.</b>	<b>Part No.</b>	<b>Description</b>
Q401,Q403	4860-0660-5	TR 2SA1015 (G.R.) RL
Q402	4851-012F-5	TR 2SD1012F/G HFE 160-560
Q404	485A-114E-5	TR DTA114ESA ROHM
Q405	485C-114E-5	TR DTC114ES ROHM
Q502	485A-950Y-5	TR 2SA950-Y HFE 100-200
Q602,Q603	4851-9230-5	TR 2SC1923-0 HFE 70-140
<b>RESISTORS</b>		
R101	4701-100J-2	RCF 1/8W 10R 5% AT
R103,R104	4711-203A-2	RMF 1/8W 20K 1% AT
R105,R110	4711-302A-2	RMF 1/8W 3K 1% AT
R106	4711-154A-2	RMF 1/8W 150K 1% AT
R107	4711-104A-2	RMF 100K 1/8W 1% AT
R108	4711-683A-2	RMF 1/8W 68K 1% AT
R109,R119	4711-153A-2	RMF 1/8W 15K 1% AT
R111,R1316	4711-472A-2	RMF 1/8W 4.7K 1% AT
R112-R114	4711-512A-2	RMF 1/8W 5.1K 1% AT
R115	4711-182A-2	RMF 1/8W 1.8K 1% AT
R116,R117	4711-123A-2	RMF 1/8W 12K 1% AT
R118	4711-103A-2	RMF 1/8W 10K 1% AT
R121-R124	4711-102A-2	RMF 1/8W 1K 1% AT
R125	4701-4R7J-C	RCF 1/8W 4.7R 5% ATS
R201	4711-472A-2	RMF 1/8W 4.7K 1% AT
R202-R207,R209-R211	4711-102A-2	RMF 1/8W 1K 1% AT
R212,R220,R225	4711-104A-2	RMF 100K 1/8W 1% AT
R213,R224,R230	4711-103A-2	RMF 1/8W 10K 1% AT
R214	4711-822A-2	RMF 1/8W 8.2K 1% AT
R215	4701-4R7J-C	RCF 1/8W 4.7R 5% ATS
R217	4711-102A-2	RMF 1/8W 1K 1% AT
R218,R219	4711-153A-2	RMF 1/8W 15K 1% AT
R223	4711-333A-2	RMF 1/8W 33K 1% AT
R226	4711-105A-2	RMF 1/8W 1M 1% AT
R227	4711-101A-2	RMF 1/8W 100R 1% AT
R228,R229	4711-332A-2	RMF 1/8W 3.3K 1% AT
R308-R310	4711-302A-2	RMF 1/8W 3K 1% AT
R311,R373	4711-104A-2	RMF 100K 1/8W 1% AT
R312,R321	4711-103A-2	RMF 1/8W 10K 1% AT
R313	4701-100J-2	RCF 1/8W 10R 5% AT
R315,R317,R332	4711-102A-2	RMF 1/8W 1K 1% AT
R318,R320	4711-471A-2	RMF 1/8W 470R 1% AT
R319,R337	4711-561A-2	RMF 1/8W 560R 1% AT
R322	4711-153A-2	RMF 1/8W 15K 1% AT
R327-R329	4711-472A-2	RMF 1/8W 4.7K 1% AT
R331,R333,R334,	4711-472A-2	RMF 1/8W 4.7K 1% AT
R335,R336,R338	4711-103A-2	RMF 1/8W 10K 1% AT
R355,R356	4711-362A-2	RMF 1/8W 3.6K 1% AT
R359,R360	4711-163A-2	RMF 1/8W 16K 1% AT
R363,R364	4711-152A-2	RMF 1/8W 1.5K 1% AT
R367,R368,R371,R372	4711-222A-2	RMF 1/8W 2.2K 1% AT
R374	4711-104A-2	RMF 100K 1/8W 1% AT

<b>Reference No.</b>	<b>Part No.</b>	<b>Description</b>
R375,R376,R379,R380,R384	4711-750A-C	RMF 1/8W 75R 1% ATS
R377,R378	4711-472A-2	RMF 1/8W 4.7K 1% AT
R381,R382	4711-472A-2	RMF 1/8W 4.7K 1% AT
R383	4711-151A-C	RMF 1/8W 150R 1% ATS
R390-R393	4717-221J-C	RMF 1/2W 220R 5% ATS
R394-R397	4711-472A-2	RMF 1/8W 4.7K 1% AT
R402	4711-102A-2	RMF 1/8W 1K 1% AT
R403	4711-103A-2	RMF 1/8W 10K 1% AT
R404	4711-362A-2	RMF 1/8W 3.6K 1% AT
R405	4711-223A-2	RMF 1/8W 22K 1% AT
R406,R415	4711-752A-2	RMF 1/8W 7.5K 1% AT
R407,R412	4711-472A-2	RMF 1/8W 4.7K 1% AT
R408,R409,R411	4711-101A-2	RMF 1/8W 100R 1% AT
R410,R414	4711-104A-2	RMF 100K 1/8W 1% AT
R413,R416	4711-473A-2	RMF 1/8W 47K 1% AT
R501,R502	4711-241A-2	RMF 1/8W 240R 1% AT
R503,R504	4711-222A-2	RMF 1/8W 2.2K 1% AT
R517,R518,R520	4711-471A-2	RMF 1/8W 470R 1% AT
R523	4711-473A-2	RMF 1/8W 47K 1% AT
R604	4711-182A-2	RMF 1/8W 1.8K 1% AT
R605	4711-103A-2	RMF 1/8W 10K 1% AT
R606	4711-152A-2	RMF 1/8W 1.5K 1% AT
R609,R614,R615,R622,R623	4711-103A-2	RMF 1/8W 10K 1% AT
R611	4711-104A-2	RMF 100K 1/8W 1% AT
R614	4711-222A-2	RMF 1/8W 2.2K 1% AT
R631A,R631B	4717-221J-C	RMF 1/2W 220R 5% ATS
<b>ICS</b>		
U101	3131-8030-0	IC CXA2581N ASP FOR CD
U201	3131-8000-0	IC CXD3017Q DSP FOR CD
U202	3131-8040-0	IC BA6392FP 4-CHANNEL BTL
U301	3131-8010-0	IC M38B59EF MICRO OTP
	3131-8010-1	IC M38B57MC MICRO MASK
U302	3131-9380-0	IC PCM1732 HDCD D/A CONVERTER
U305,U306	3130-9340-0	IC OPA2604 OPAMP DIP8
U402	3130-9320-0	IC NADLINK (MASKED)
U403	3130-4160-0	IC TC74HC00AP DIGITAL
U501,U506	3130-2020-3	IC 7805 REG 5V 1.5A
U502	3130-5610-0	IC LM317T+ADJ REGULATOR
U503	3130-5620-0	IC LM337T-ADJ REGULATOR
U507	3130-2790-1	IC NJM7808FA +8V REG
U601	3130-4990-0	IC LM393D DUAL VOLTAGE

- NOTE:**
- The components identified by  $\triangle$  mark are critical for risk of fire and electrical shock. Replace only with part number specified.
  - <\*AH > : USA, Canadian model only.
  - <\*C > : European model only.
  - Capacitors : CP-Polystyrene, CM-Mylar, CE-Electrolytic, CC-Ceramic, CTC-NPO.
  - Resistors : RMF-Metal Film, RCF-Carbon Film, RWR-Wirewound Metal Oxide.

# MECHANISM EXPLODED VIEW

WSL-2130CCM

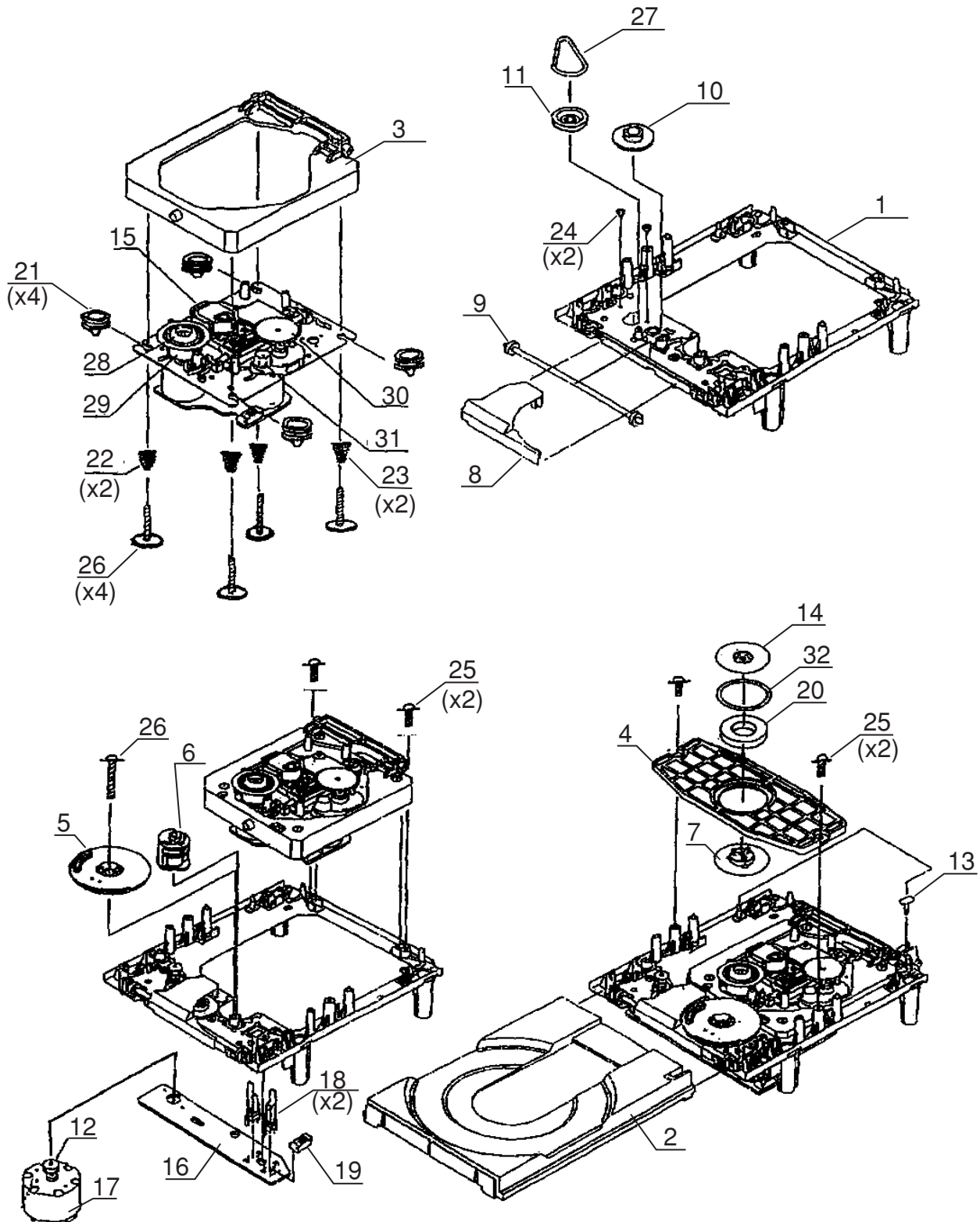



## MECHANISM EXPLODED VIEW PARTS LIST

<b>Item</b>	<b>Part No.</b>	<b>Description</b>	<b>Qty</b>
1	4102-9000-0	Outside Main Chassis	1
2	4102-9001-0	Tray	1
3	4102-9002-0	Subchassis	1
4	4102-9003-0	Chucking Plate	1
5	4102-9004-0	Drive Gear	1
6	4102-9005-0	Control Cam	1
7	4102-9006-0	Chucking Pulley	1
8	4102-9007-0	Gear Cover	1
9	4102-9008-0	Tray Gear	1
10	4102-9009-0	Intermediate Gear	1
11	4102-9010-0	Loading Pulley	1
12	4102-9011-0	Motor Pulley	1
13	4102-9012-0	SW Pin	1
14	4102-9013-0	Chucking Yoke	1
15	4102-9014-0	Optical Pickup Unit	1
16	4102-9015-0	Loading PWB	1
17	4102-9016-0	Motor RF-500TB-14415	1
18	4102-9017-0	Leaf Switch	1
19	4102-9018-0	Connector pin (5P)	1
20	4102-9019-0	Magnet	1
21	4102-9020-0	Insulator	4
22	4102-9021-0	Coil Spring (Front)	2
23	4102-9022-0	Coil Spring (Rear)	2
24	4102-9023-0	Screw-Motor M2.6x2.5	2
25	4102-9024-0	Screw M2.6x7	2
26	4102-9025-0	Screw Washer Based M2.6x16	4
27	4102-9026-0	Rubber Belt	1
28	4102-9027-0	Center Ring	1
29	4102-9028-0	Turn Table	1
30	4102-9029-0	Gear (A)	1
31	4102-9030-0	Motor Gear	1
32	4102-9031-0	Damper	1

# EXPLODED VIEW

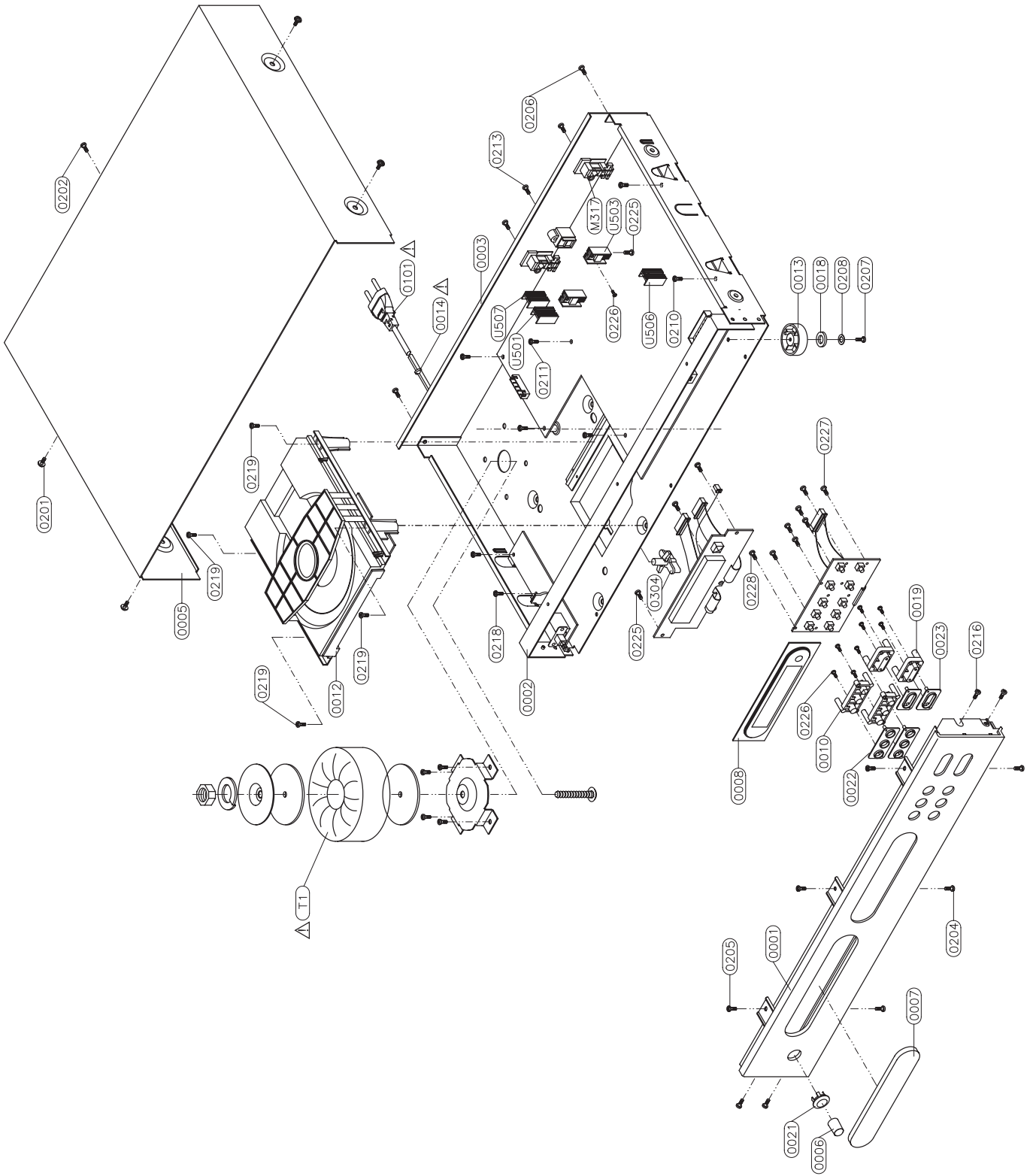

# EXPLODED VIEW PARTS LIST

<u>Item</u>	<u>Part No.</u>	<u>Description</u>	<u>Qty</u>
0001	1465-5706-3	FASSCIA W/SS PAINT	1
0002	1402-3781-2	STARP	1
0003*AH	1402-3522-0	CHASSIS W/SS PAINT	1
0003*C	1402-3523-0	CHASSIS W/SS PAINT	1
0005	1402-3530-0	COVER	1
0006	2442-1000-0	POWER BUTTON	1
0007	4154-4191-0	CD DOOR W/SS PAINT	1
0008	3716-4316-0	WINDOW LENS W/SS	1
0010	2444-1201-0	BUTTON TRIO	2
0012	4111-1051-0	CD DECK	1
0013	4152-4631-0	RUBBER FOOT 14MM HIGH	4
0014 $\triangle$	4151-9461-0	STRAIN RELIEF BUSHING 4N-4	1
0018	4152-4641-0	CUSHION FOOT	4
0019	2444-1301-1	BUTTON RACKER	2
0021	4152-4331-0	POWER BUTTON BEZEL	1
0022	4154-0031-0	BEZEL TRIO	2
0023	4154-0091-0	BEZEL RACKER	2
0027	4104-3721-0	TRANSFORMER BRACKET	1
0101*AH $\triangle$	7009-3100-2	AC CORD 18AWGX2 SPT-2 D.INSULATED UL/CSA	1
0101*C $\triangle$	7009-3110-0	AC CORD SEMKO	1
0201	2900-4006-3010	M4X0.5PX6MM W/FLAT WASHER	8
0202	2954-3008-3000	T3X8MM SELF TAPPING	12
0205	2954-3008-0000	TAPPING 3X8MM B-TITE(YEL.ZN)	17
0208	2842-3367-0	METAL WASHER ID=3.3 OD=6.7	4
0211	2904-3006-0000	SCREW M3X6	4
0218	2954-3006-0000	3X6MM B-TITE (YEL.ZN)	2
0219	2904-3008-3000	SCREW M3X8	4
0226	2954-2006-0000	TAPPING SCREW 2X6	13
0227	2954-2608-0000	SCREW BT 2.6X8	7
0228	2950-2608-3000	SCREW PAN HEAD,B-TITE 2.6X8 BLACK	1
0304	1463-160B-0	CD RANSIT LOCK (RED)	1
T1 $\triangle$	1806-2512-0	TRANSFORMER I/P 120/230V	1
U501-U503	5400-9130-0	HEAT SINK FOR 7805 2438-17	3
U506-U507	5400-9130-0	HEAT SINK FOR 7805 2438-17	2

- NOTE:**
- The components identified by  $\triangle$  mark are critical for risk of fire and electrical shock. Replace only with part number specified.
  - <\*AH > : USA, Canadian model only.
  - <\*C > : European model only.

# PACKING DIAGRAM

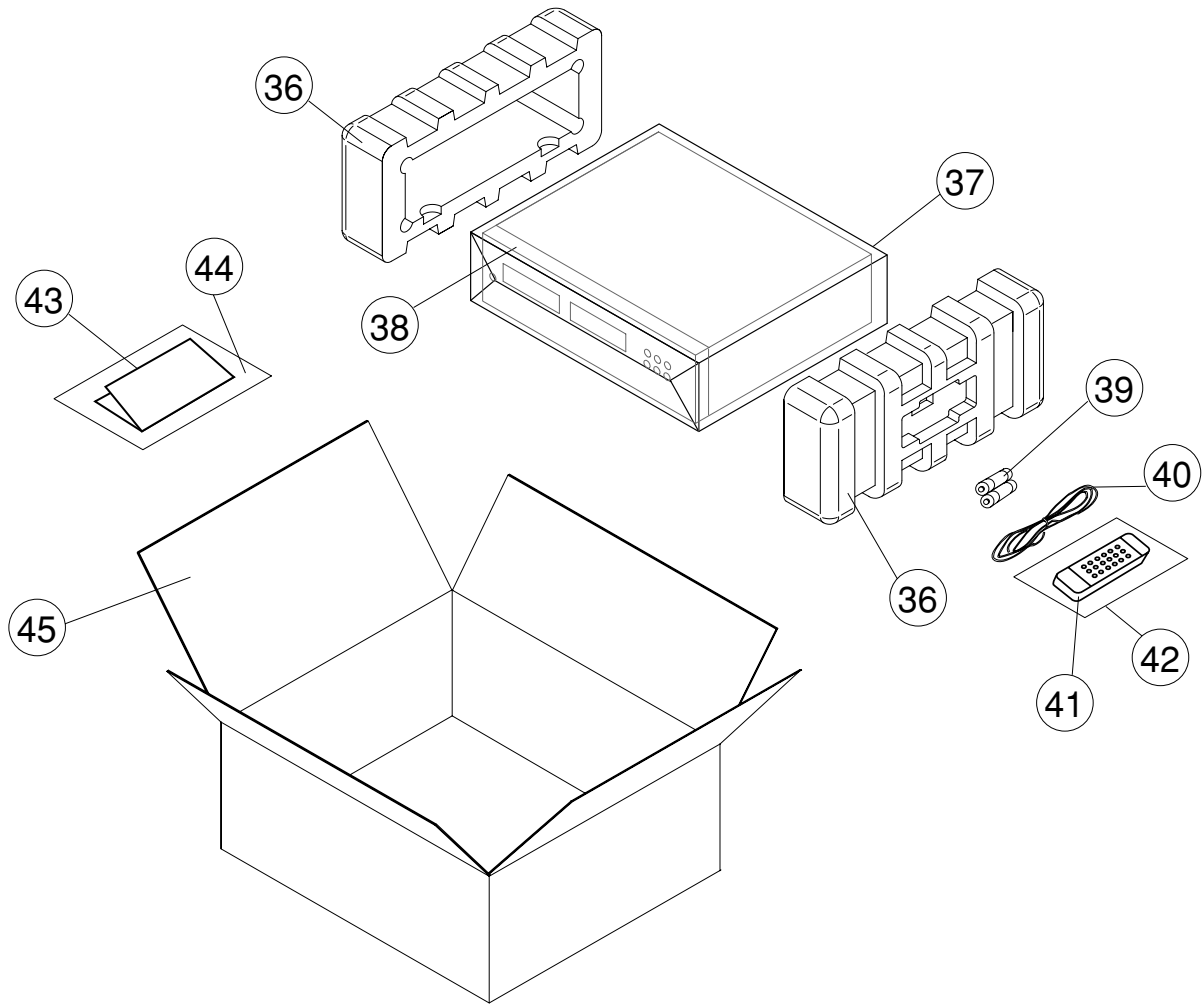

ITEM	PART NO.	DESCRIPTION	Q'TY
36	1490-3783-1	POLYFOAM ENDCAP	2
37	1497-1332-1	UNIT POLYBAG	1
38	1497-1432-0	FASCIA COVER	1
39	4060-0530-0	BATTERIES	2
40	2103-7302-1	RCA CABLE	1
41	8912-0005-0	REMOTE CONTROL HANDDSET	1
42	1497-1302-0	REMOTE CONTROL POLYBAG	1
43	4301-4105-0	INSTRUCTION MANUAL	1
44	1497-1062-0	MANUAL POLYBAG	1
45	1435-8400-0-2	CARTON BOX	1

Proprietary information for servicing purposes only. The information herein may not be used commercially without the prior written agreement of NAD Electronics International, Toronto, Canada.

# SERVICE MANUAL

# C 541i

COMPACT  
DISC PLAYER

© NAD 2002

NAD ELECTRONICS INTERNATIONAL  
TORONTO