

C 565BEE

**COMPACT
DISC PLAYER**

C 565BEE

**COMPACT
DISC PLAYER**

SERVICE MANUAL



SAFETY INFORMATION

CAUTION

**CLASS 1
LASER PRODUCT**

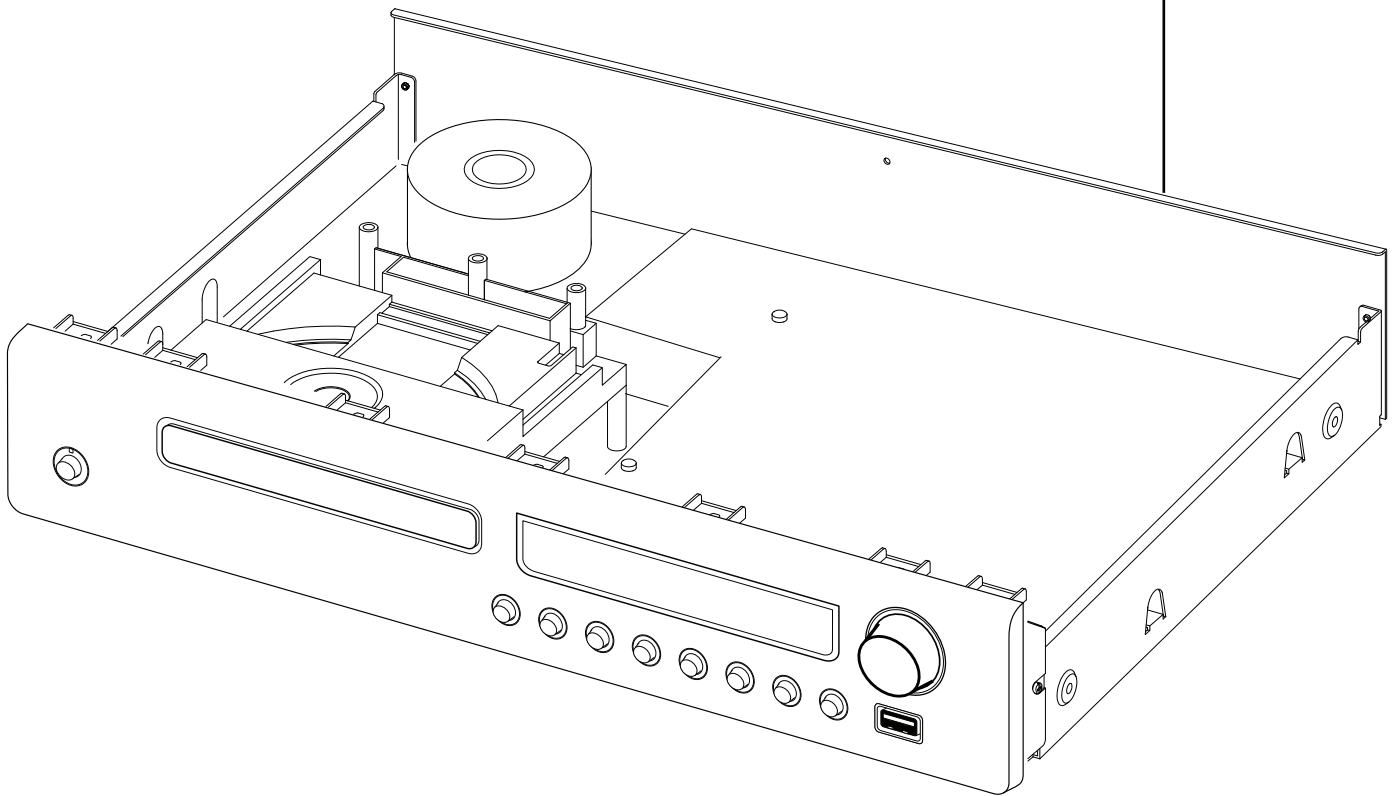

The lightning flash with arrowhead, within an equilateral triangle is intended to alert the user of the presence of uninsulated "dangerous voltage" within the product's enclosure; that may be of sufficient magnitude to constitute a risk of electric shock to persons.



The exclamation point within an equilateral triangle is intended to alert the user of the presence of important operating and maintenance (servicing) instructions in the literature accompanying the appliance.

THIS DEVICE COMPLIES WITH PART 15 OF THE FCC RULES.
OPERATION IS SUBJECT TO THE FOLLOWING TWO CONDITIONS:-
(1) THIS DEVICE MAY NOT CAUSE HARMFUL INTERFERENCE, AND
(2) THIS DEVICE MUST ACCEPT ANY INTERFERENCE RECEIVED,
INCLUDING INTERFERENCE THAT MAY CAUSE UNDESIRE
OPERATION.

SERVICE SAFETY PRECAUTIONS

1. Replacing the fuses

CAUTION: FOR CONTINUED PROTECTION AGAINST THE RISK OF FIRE REPLACE ONLY WITH SAME TYPE OF FUSE.

Reference No	Part Number	Description
FC200 \triangle	5120-0050+0	FUSE T1.6A/250V 5X20
FC201, FC202 \triangle	5120-0018+0	FUSE T1A 250V 5X20
FC203 \triangle	5120-0035+0	FU T100MA 250V
FC204 \triangle	5120-0018+0	FUSE T1A 250V 5X20
FC205 \triangle	5120-1096+0	FUSE 0.8A 250V 8X7 UL

NOTE:

<*AH > : USA, CANADIAN MODEL ONLY.

<*C > : EUROPEAN MODEL ONLY.

2. Safety check out

(Only U.S.A. model)

Before returning the product to the customer, make leakage current or resistance measurements to determine that exposed parts are acceptably insulated from the supply circuit.

Parts marked with the symbol \triangle are critical with regard to the risk of fire and electric shock. Replace only with parts recommended by the manufacturer.

CONTENTS

DESCRIPTION	PAGE
SPECIFICATIONS	4
REAR PANEL / FRONT PANEL	5
DISASSEMBLY INSTRUCTIONS	6
BLOCK DIAGRAM	7
WIRING DIAGRAM	8
RF PATTERN TESTING	9
IMPORTANT NOTES	10-13
PCB LAYOUT	14-17
SCHEMATIC DIAGRAM	18-23
IC BLOCK DIAGRAM	24-33
TROUBLESHOOTING GUIDE	34
ELECTRICAL PARTS LIST	35-50
MECHANISM EXPLODED VIEW	51
MECHANISM EXPLODED VIEW PARTS LIST	52
EXPLODED VIEW	53
EXPLODED VIEW PARTS LIST	54-55
PACKING DIAGRAM	56

SPECIFICATIONS

GENERAL PARAMETERS

Output level - Analog	2.2 ± 0.1 V
Optical	-22.5 ± 3.5 dBm
Coaxial	650 ± 150 mV
Frequency response	± 0.3 dB (ref. 0 dB 20 Hz-1 kHz) ± 0.5 dB (ref. 0 dB 5 kHz-20 kHz)
Total harmonic distortion	< 0.01% (ref. 1 kHz)
Signal/Noise ratio	118 dB (A-weighted, ref. 1 kHz)
Channel balance	± 0.5 dB (ref. 0dB 1kHz)
Dynamic range	95 dB
Channel separation	> 90 dB
De-emphasis	-3.73 to -5.33 dB (ref. 0dB 5 kHz) -8.04 to -10.04 dB (ref. 0 dB 16 kHz)
Linearity	± 0.01 dB (ref. 1 kHz at -3 dB) ± 0.02 dB (ref. 1 kHz at -6 dB) ± 0.02 dB (ref. 1 kHz at -10 dB) ± 0.05 dB (ref. 1 kHz at -20 dB) ± 0.15 dB (ref. 1 kHz at -60 dB)

POWER CONSUMPTION

Rated power	18 W (ref. 230V AC 50 Hz; 120V AC 60 Hz)
Standby power	< 1 W (230V version only) < 0.7 W (120V version only)
Idle power	< 15 W

DIMENSION AND WEIGHT

Unit Dimensions (W x H x D)	435 x 285 x 70 mm (Net) 435 x 293 x 86 mm (Gross)*
Net weight	4.9 kg
Shipping weight	6.3 kg

* - Gross dimensions include feet, extended buttons and rear panel terminals.

REAR PANEL / FRONT PANEL

REAR PANEL

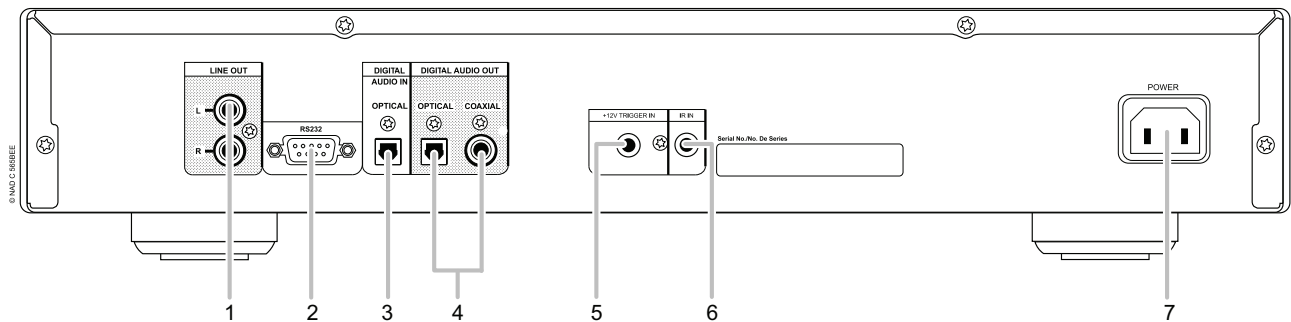

- | | |
|-----------------------------------|-----------------------|
| 1. LINE OUT | 5. +12V TRIGGER INPUT |
| 2. RS232 | 6. IR IN |
| 3. DIGITAL AUDIO IN (OPTICAL) | 7. AC MAINS INPUT |
| 4. DIGITAL OUT (COAXIAL, OPTICAL) | |

FRONT PANEL

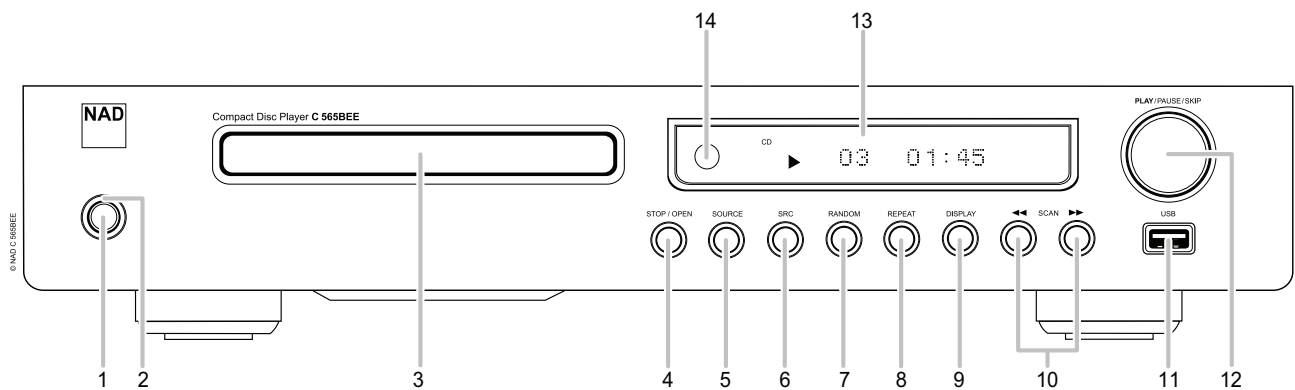

- | | |
|-------------------|---------------------|
| 1. STANDBY BUTTON | 8. REPEAT |
| 2. STANDBY LED | 9. DISPLAY |
| 3. DISC TRAY | 10. SCAN |
| 4. STOP/OPEN | 11. USB INPUT |
| 5. SOURCE | 12. PLAY/PAUSE/SKIP |
| 6. SRC | 13. VFD |
| 7. RANDOM | 14. REMOTE SENSOR |

DISASSEMBLY INSTRUCTIONS

1. Remove machine screws M 4.0 x 6.0 (① to ④) from the side panels.
Remove tapping screw 3.0 x 8.5 (⑤) from the back panel.
Refer to **Figure No.1**.

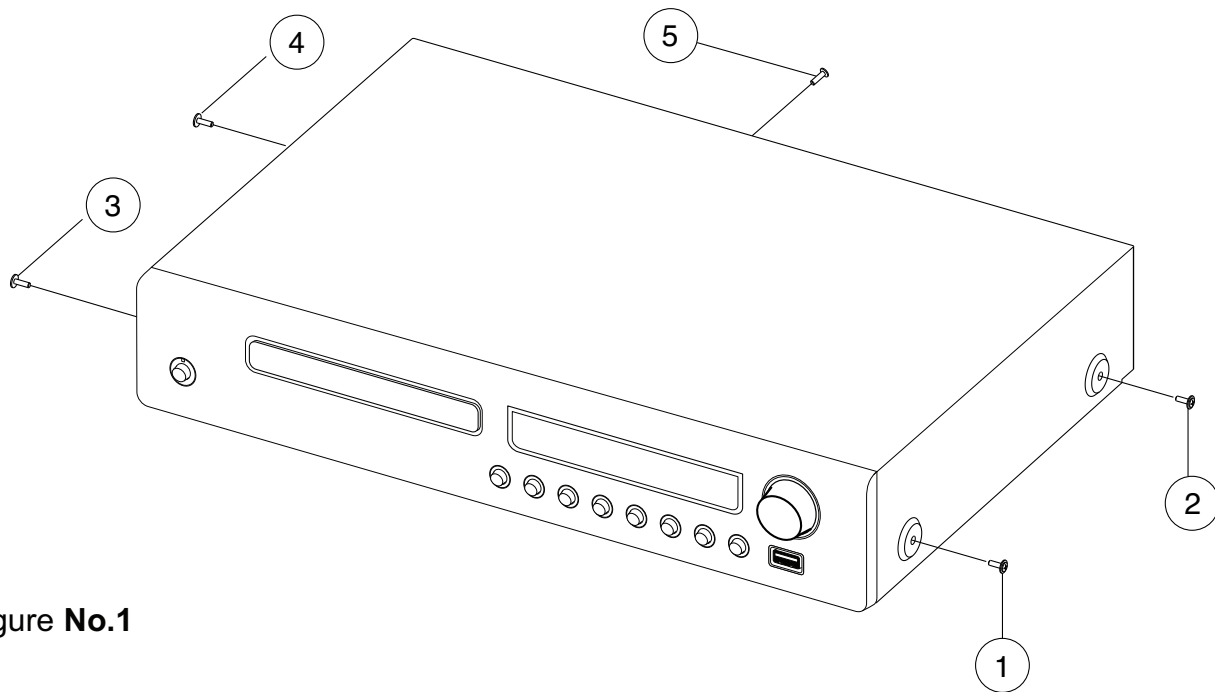

Figure No.1

2. Pull both sides of the TOP COVER slightly outwards (⑥) and tilt approx. 35° and then remove in the direction as indicated by the arrow (⑦). Refer to **Figure No.2**.

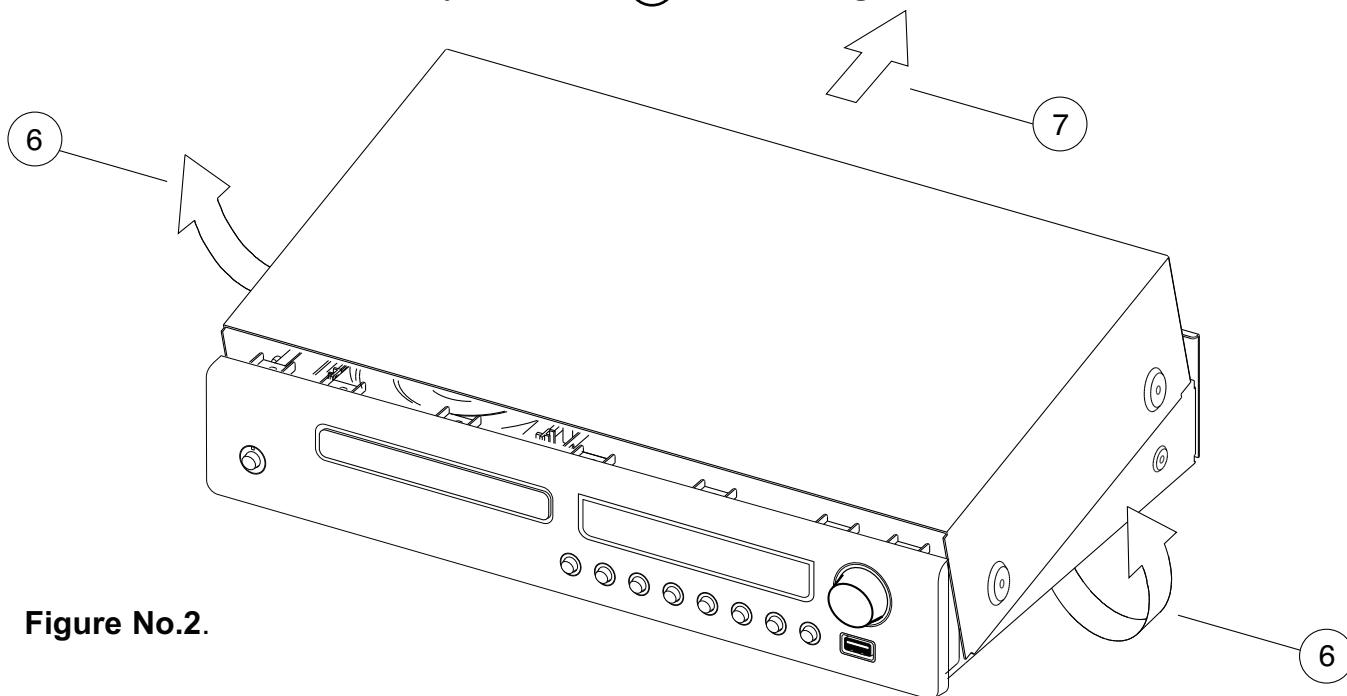
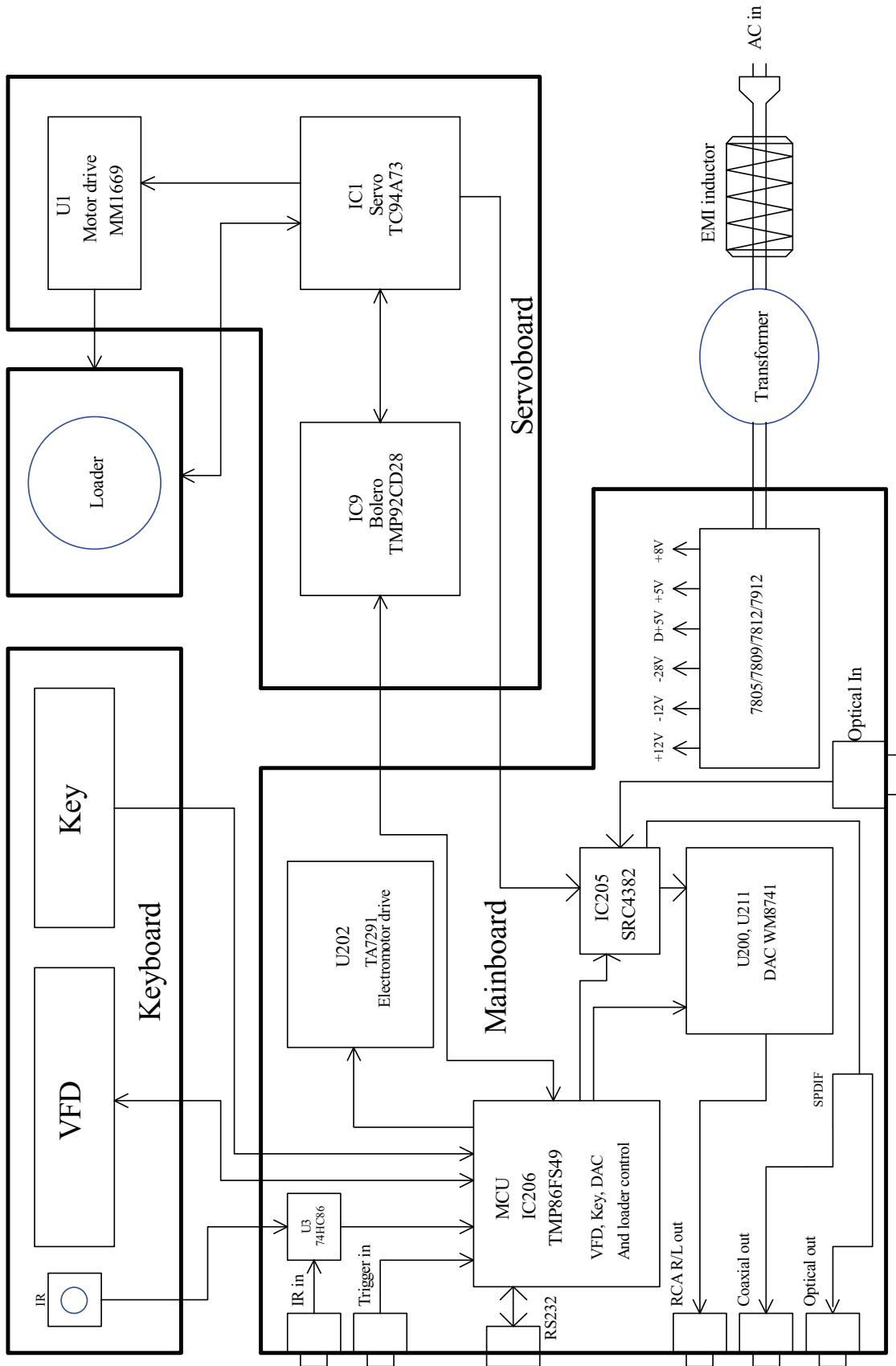
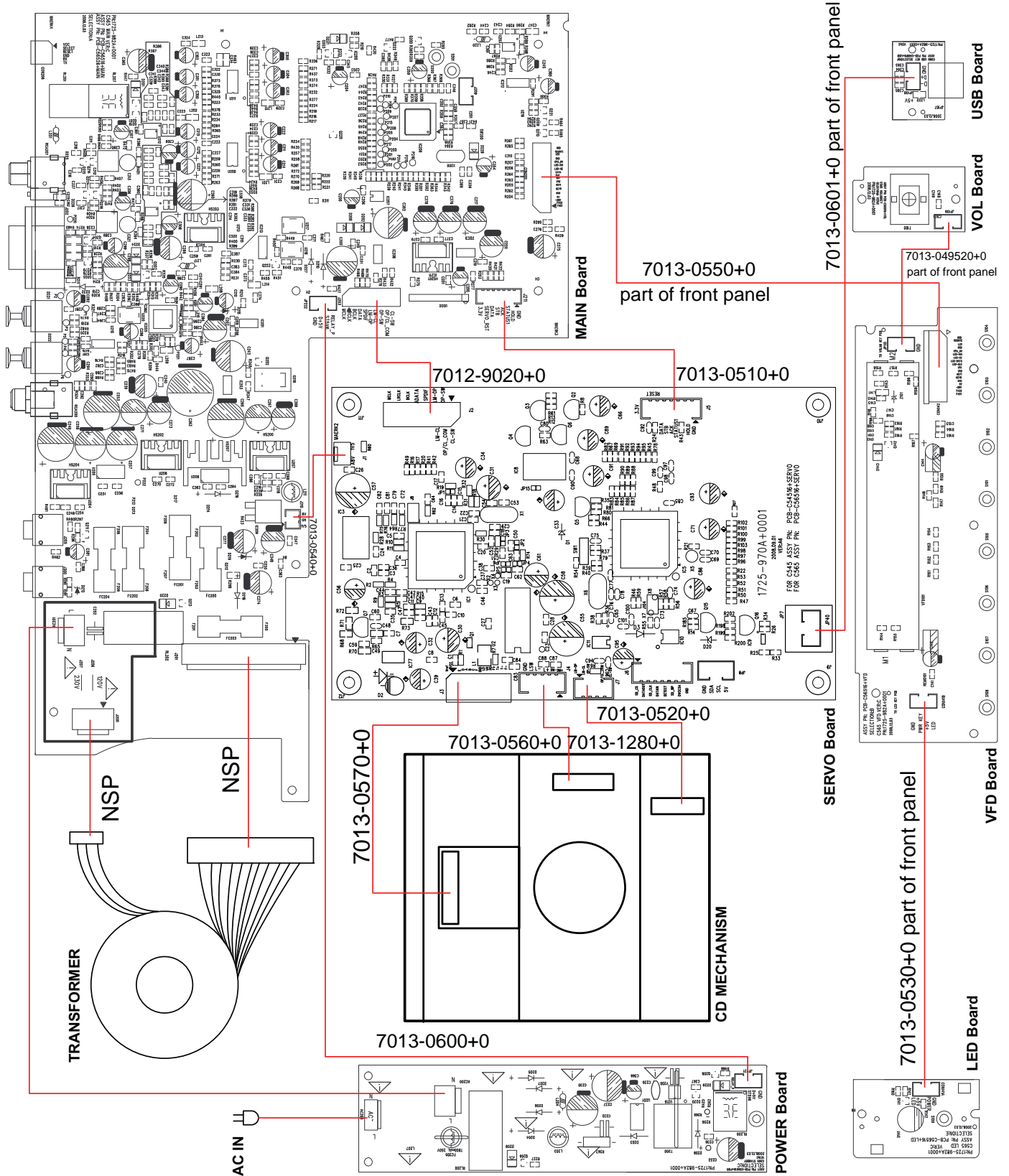

Figure No.2.

BLOCK DIAGRAM



WIRING DIAGRAM



RF PATTERN TESTING

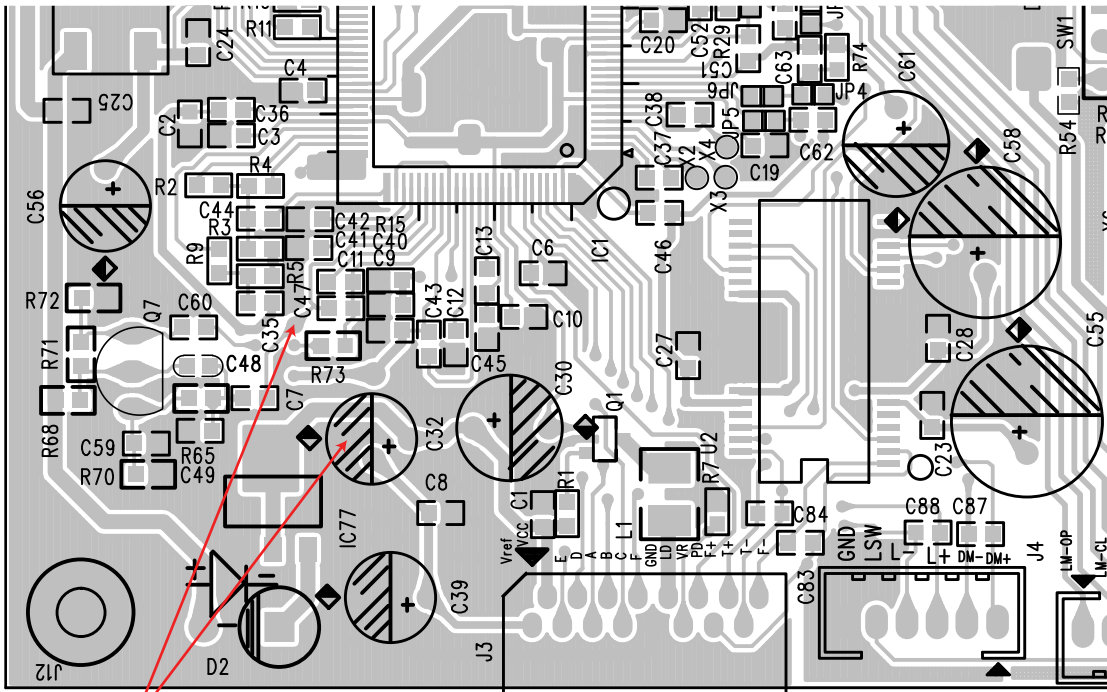

Test Point

NAD - C 565BEE PCB TESTING POINTS DIAGRAM

TESTING PROCEDURE

- (1) Load the test disc (Sony Test CD YEDS-7) and set the unit into PLAY mode.
- (2) Connect the scope to C7 (Pin 81 of IC1) and DGND (C32).

Scope setting:

Coupling	: AC.
Vertical sensitivity	: 0.2 V/ div.
Horizontal time base	: 0.5 μ S/div.

- (3) Observe the waveform is 1.5V p-p +/-5% and the eye pattern is at its best shape (see **FIG. 1**).

FIG. 1 (a)

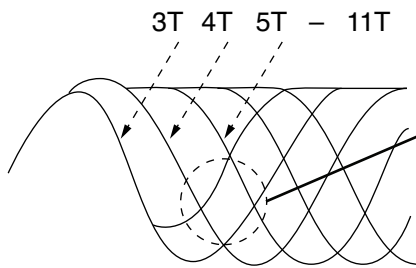

FIG. 1 (b) Poor eye pattern

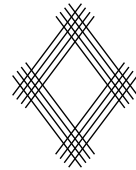
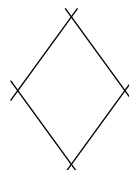

FIG. 1 (C) Good eye pattern



IMPORTANT NOTES

INSTRUCTION FOR HANDLING OPTICAL SYSTEM BLOCK PICK-UP

Electrostatic breakdown of the laser diode in the optical system block may occur due to a potential difference caused by electrostatic charge accumulated on clothing, human body, etc. A ground must be provided as follows to prevent any electrostatic charge during unpacking or repair work.

1. Ground for Human Body

Be sure to wear a ground band (1M ohm) that is properly to remove any static electricity that may be charged on the body.

2. Ground for Work Bench

Be sure to place a conductive sheet (1M ohm) or copper plate with proper grounding on the work bench or other surface on which the pick-up is to be placed.

3. Because the static electricity charge on the clothing does not discharge through the body grounding band, do not let clothing to get in contact with the pick-up unit.

INCORRECT



CORRECT

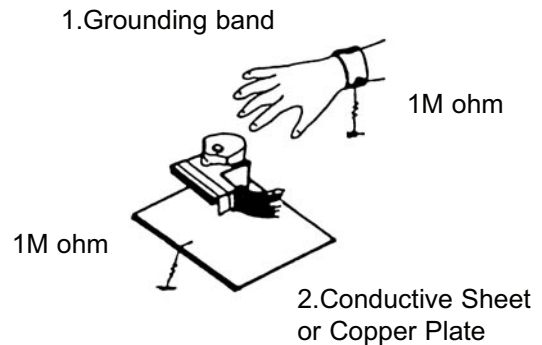

NOTE: Laser diodes are so susceptible to damage from static electricity that even if a static discharge does not ruin the diode, it can shorten its life or cause it to work improperly.

PRECAUTIONS FOR CHECKING BEAM EMISSION

The laser beam of this unit is focused on the reflecting surface of the objective lens in the optical system block. Therefore, keep your eyes at least 12 inches (30 cm) away from the objective lens when the laser diode is **ON**. (Operation Check Method for Laser Diode and Focus Search Function.)

When the **POWER** switch is turned **ON** after the chucking plate is removed, observe the objective lens and confirm that the following operations are performed properly.

(The optical system should be at the lead-in area position when it is checked at this time.)

- (1) The laser should be at the innermost position after the chucking plate is removed.
- (2) The diffused light of the laser beam can be seen when the **POWER** switch is turned **ON**.
- (3) Vertical (up and down) movement of the objective lens (2 or 3 times) will take place.

PRECAUTIONS WHEN CHANGING LASER PICK-UP

When removing the pick-up assembly, short circuit the PCB tracks on the optical block as show in the drawing in order to protect the pick-up before removal.

NOTE: Replacement pick-up assemblies are supplied with the PCB pattern already protected.

DO NOT REMOVE THE SHORT CIRCUITS UNTIL YOU HAVE FINISHED FITTING THE PICK-UP.

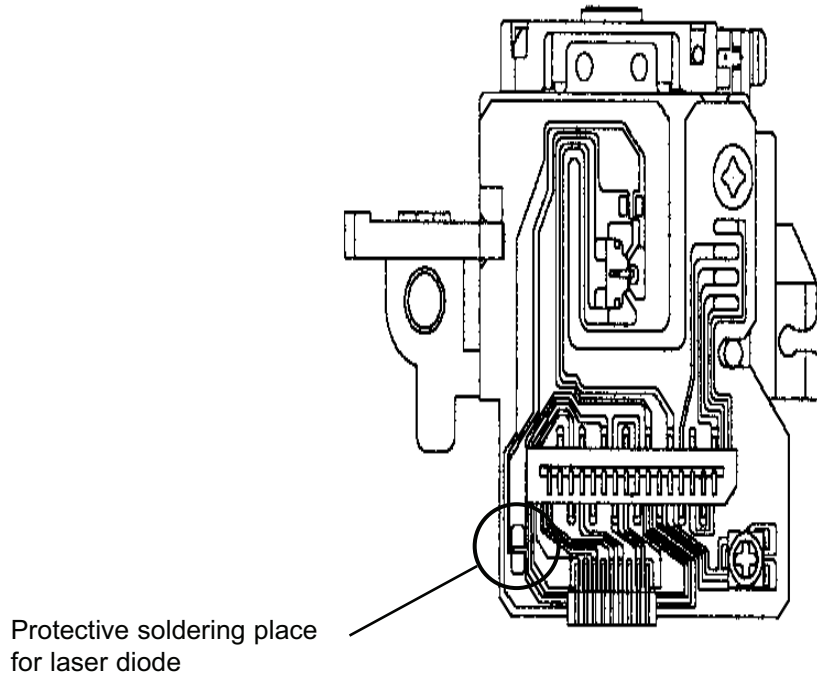

Caution:

Laser diodes are extremely susceptible to damage from static electricity. Even if a static discharge does not ruin the diode, it can shorten its life or cause it to work improperly. When replacing the pick-up, use a conductive mat, a grounded soldering iron, and so on, to protect the laser diode from static damage.

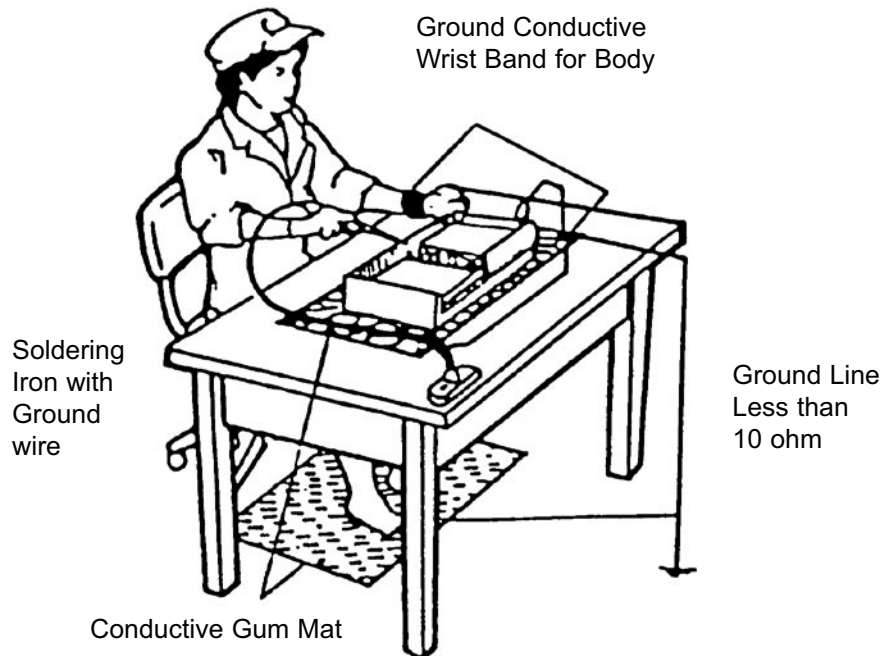

MULTI-KEY TABLE FOR C565BEE (original production)

Item	Content	Multi-key
1	VFD full segment display	SRC + SCAN BACK
2	Playtime total	RANDOM + SCAN FORWARD
3	Eject times count	RANDOM + SCAN BACK

NOTES

New special key functions (MCU v1.3.8. & Servo v4.4.)

-Playtime total counter : Random + Scan Back for 5 sec.

-Open tray (Eject times) counter : Random + Scan Back for 5 sec.

-Counter reset : Random + Display for 5 sec, then press password 5-4-5-5-6-5 using remote.

-Auto-standby on/off : Random + Play for 5 sec.

-VFD full segment display : Press SRC + Scan Forward for 5 sec.

NOTES

A series of horizontal dashed lines spanning the width of the page, intended for taking notes.

PCB LAYOUT

MAIN BOARD - top side

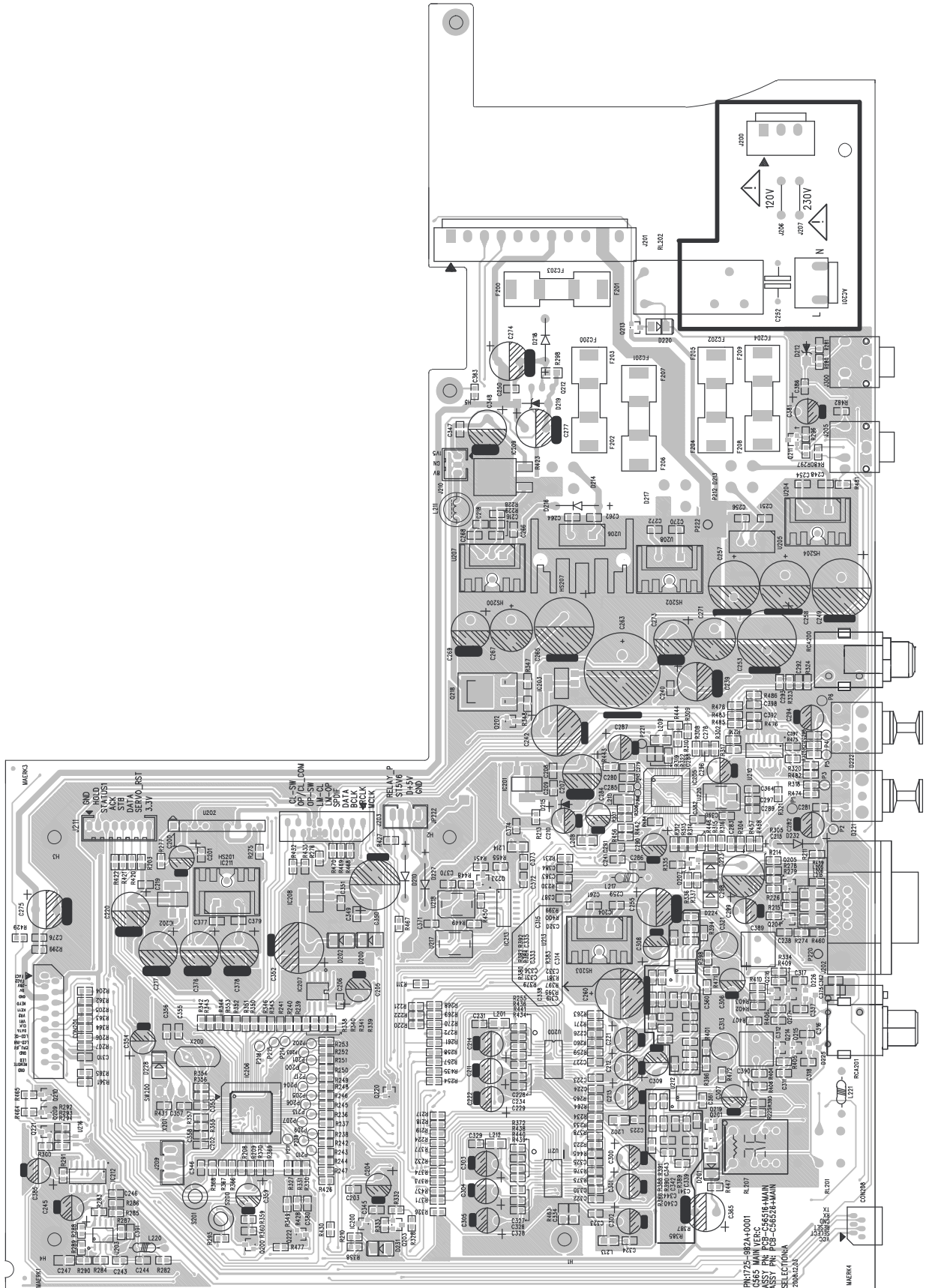

MAIN BOARD - bottom side

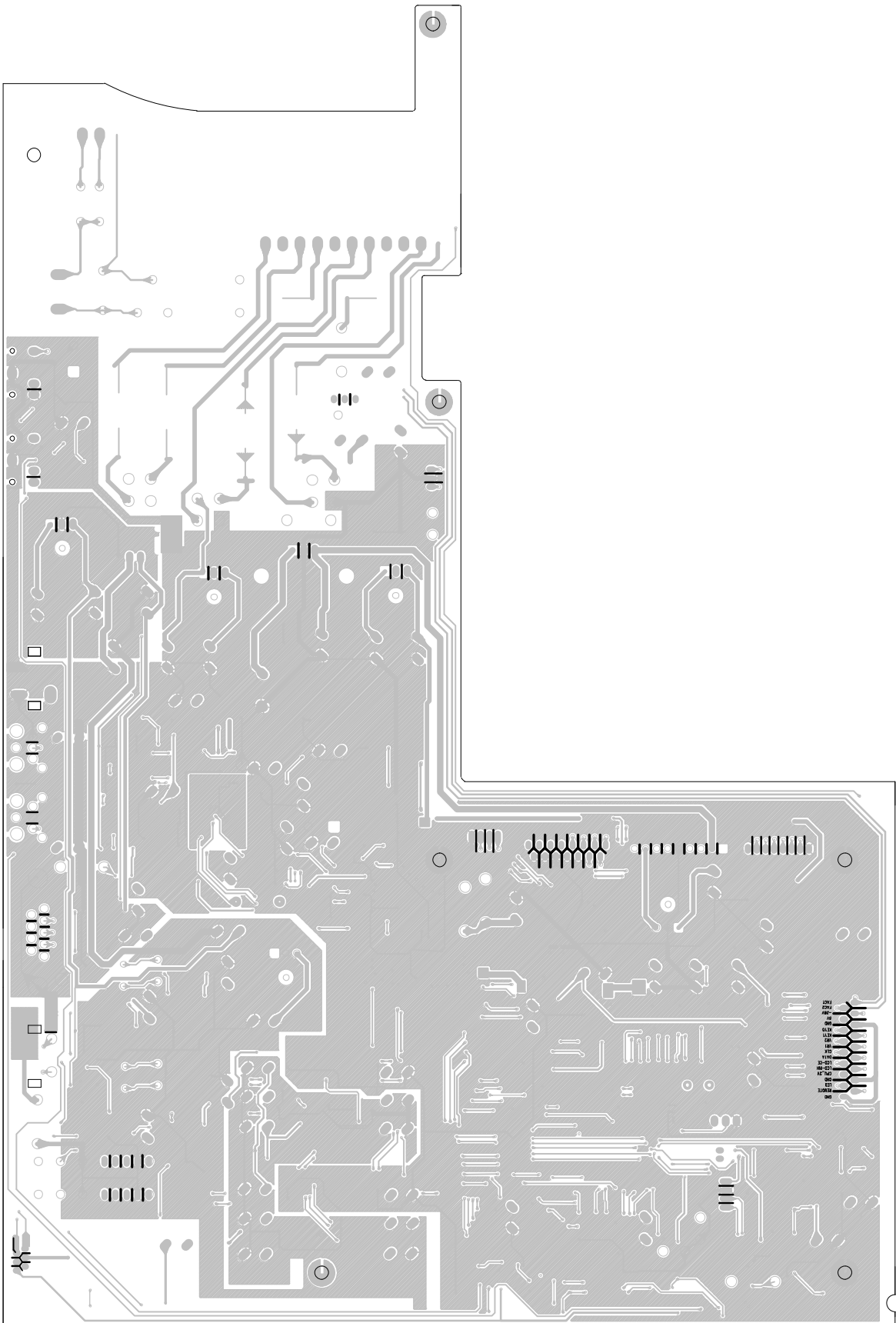

POWER BOARD

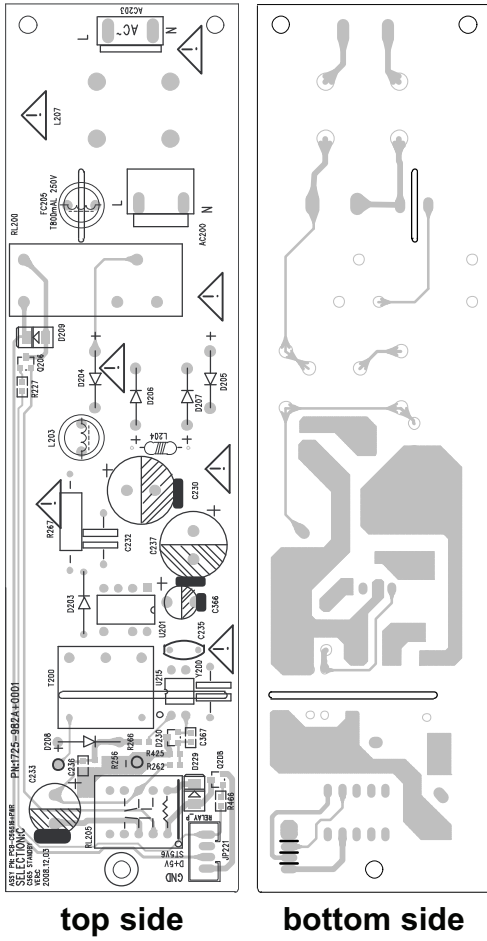

top side

bottom side

VOL BOARD

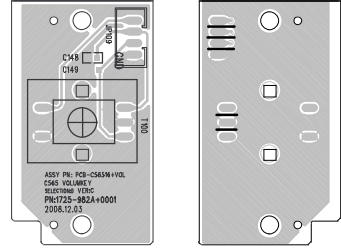

top side

bottom side

LED BOARD

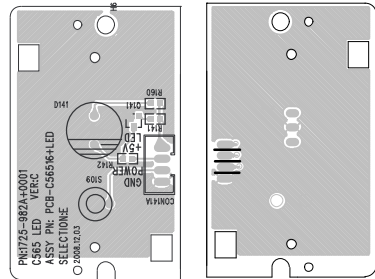

top side

bottom side

USB BOARD

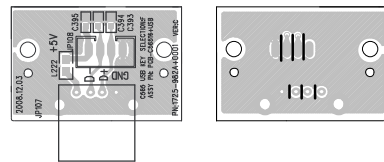

top side

bottom side

VFD BOARD

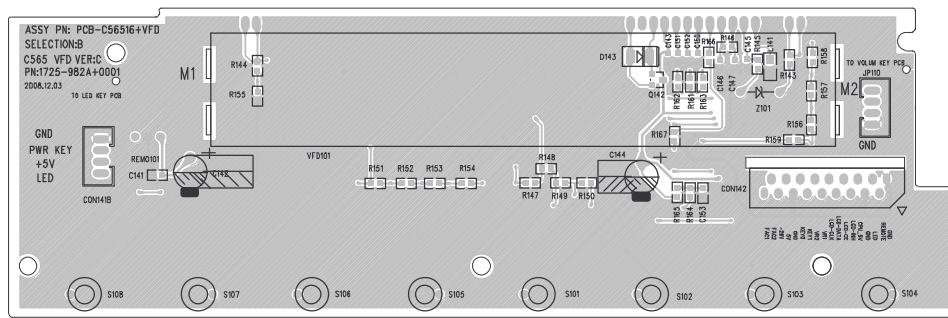

top side

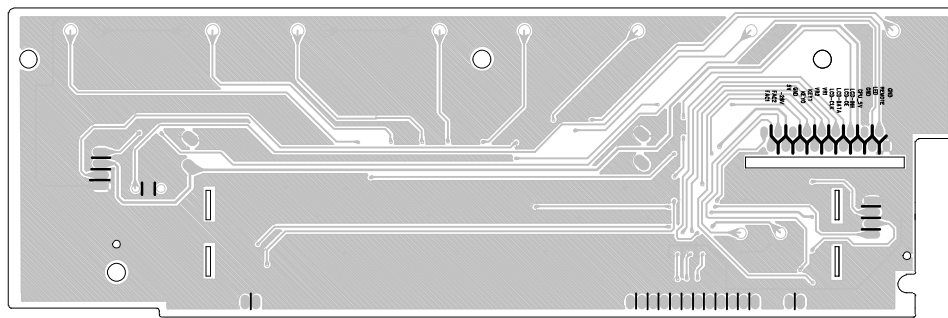

bottom side

SERVO BOARD

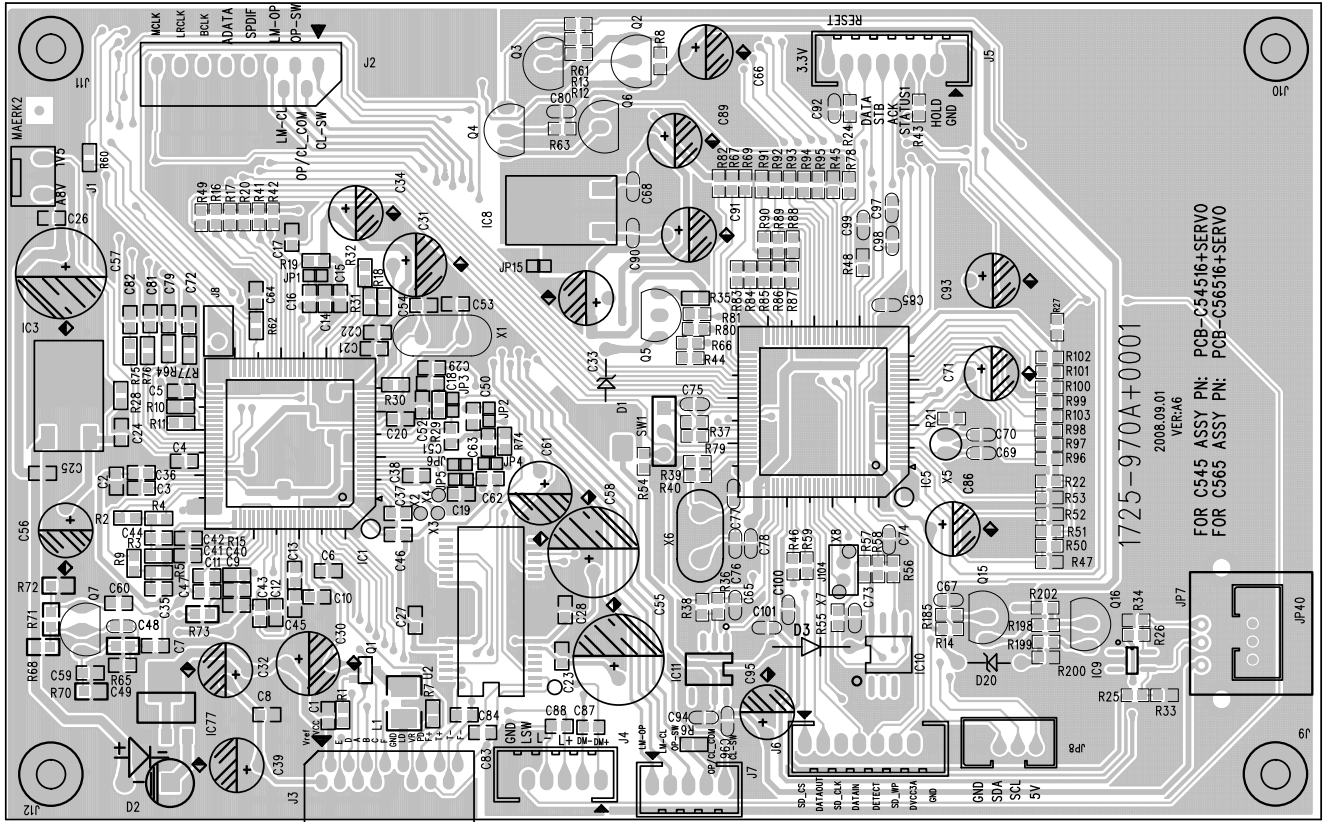

top side

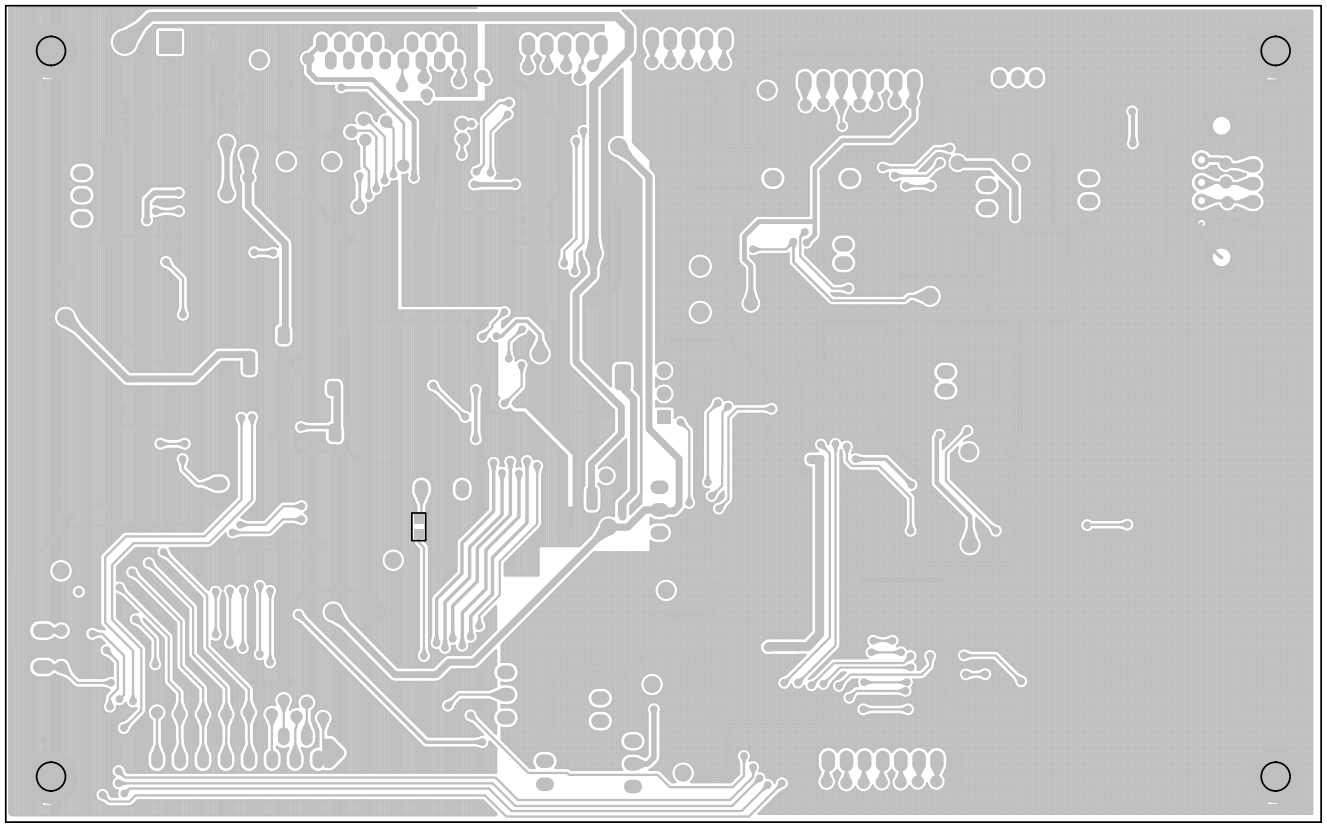

bottom side

SCHEMATIC DIAGRAM

DAC

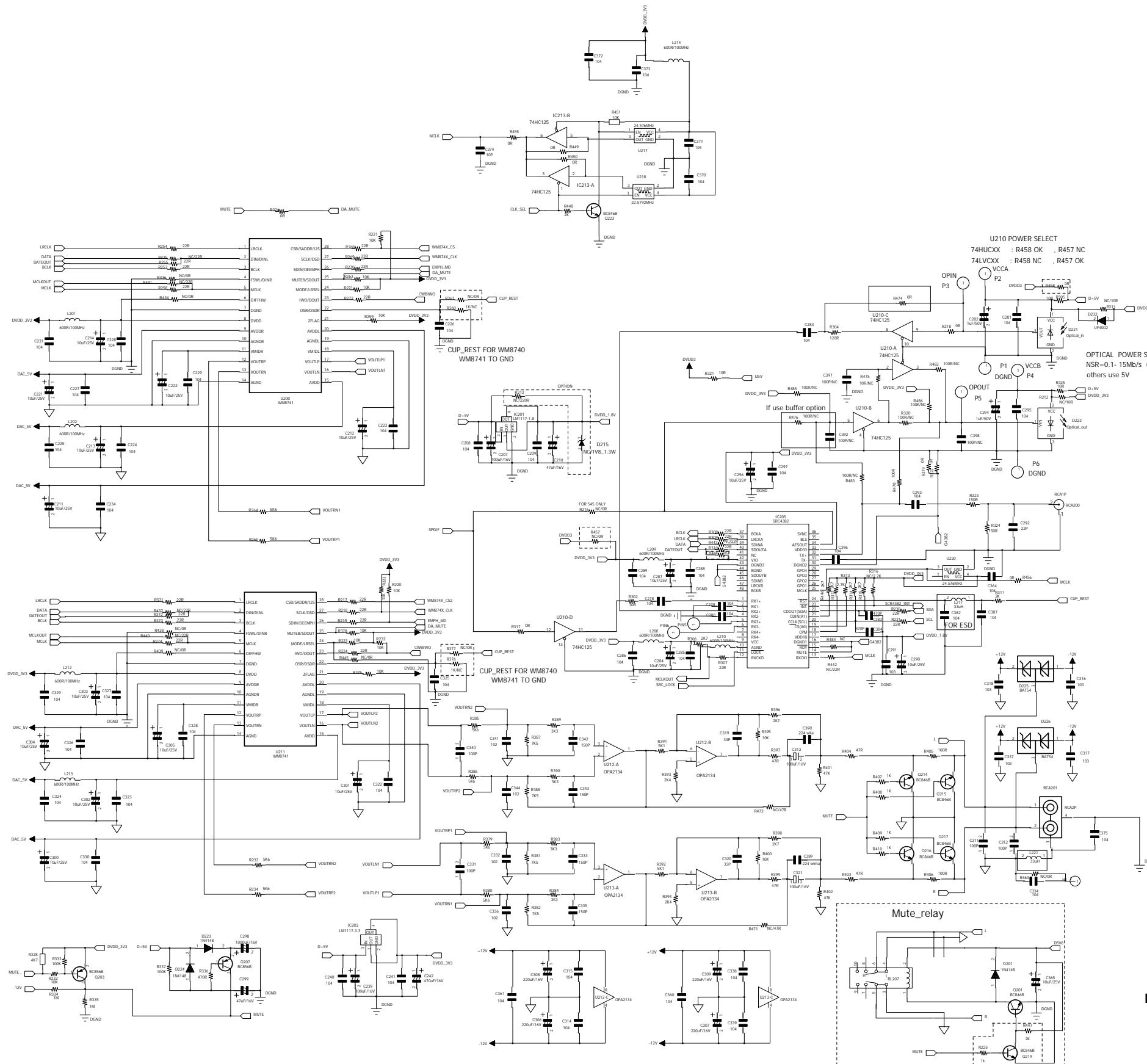

NOTE: 1. RESISTORS, ARE CARBON FILM 5% 1/8W UNLESS OTHERWISE SPECIFIED.
2. CERAMIC CAPACITORS, ARE 50V 10%. UNLESS OTHERWISE SPECIFIED.

MCU, RS232, TRIGGER IN, IR IN

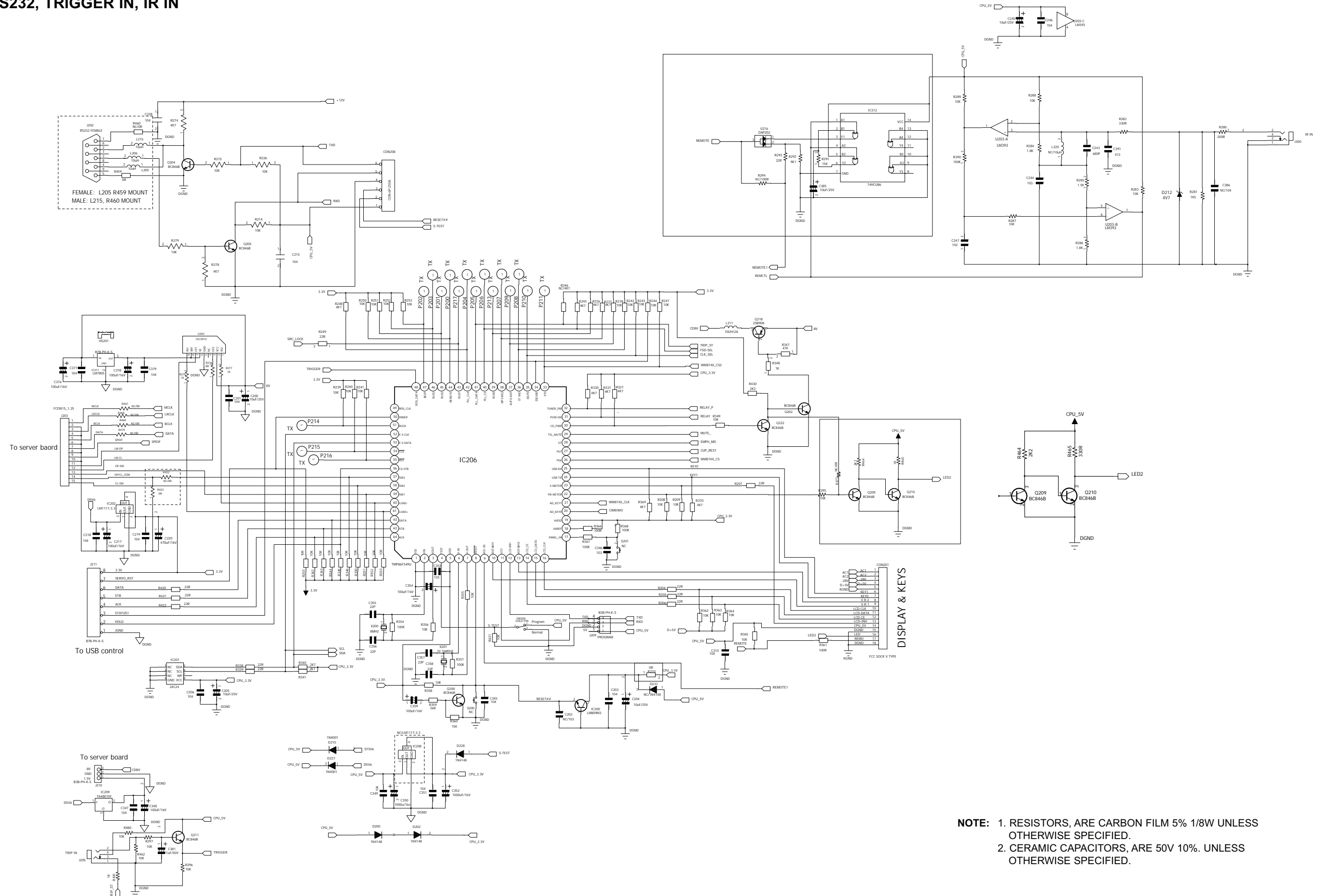

NOTE: 1. RESISTORS, ARE CARBON FILM 5% 1/8W UNLESS OTHERWISE SPECIFIED.
 2. CERAMIC CAPACITORS, ARE 50V 10%. UNLESS OTHERWISE SPECIFIED.

POWER

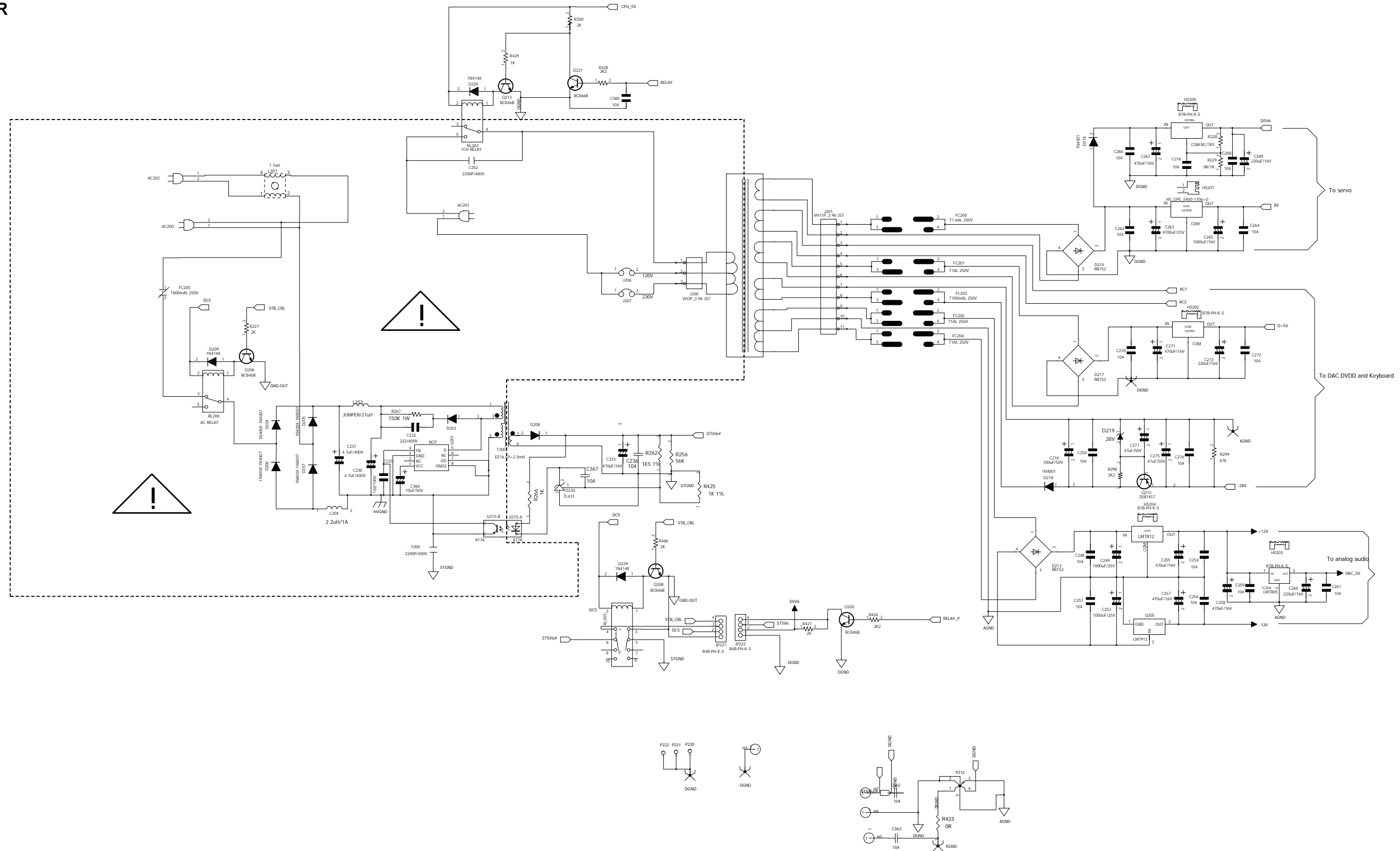

NOTE: 1. RESISTORS, ARE CARBON FILM 5% 1/8W UNLESS OTHERWISE SPECIFIED.
 2. CERAMIC CAPACITORS, ARE 50V 10%. UNLESS OTHERWISE SPECIFIED.

KEY

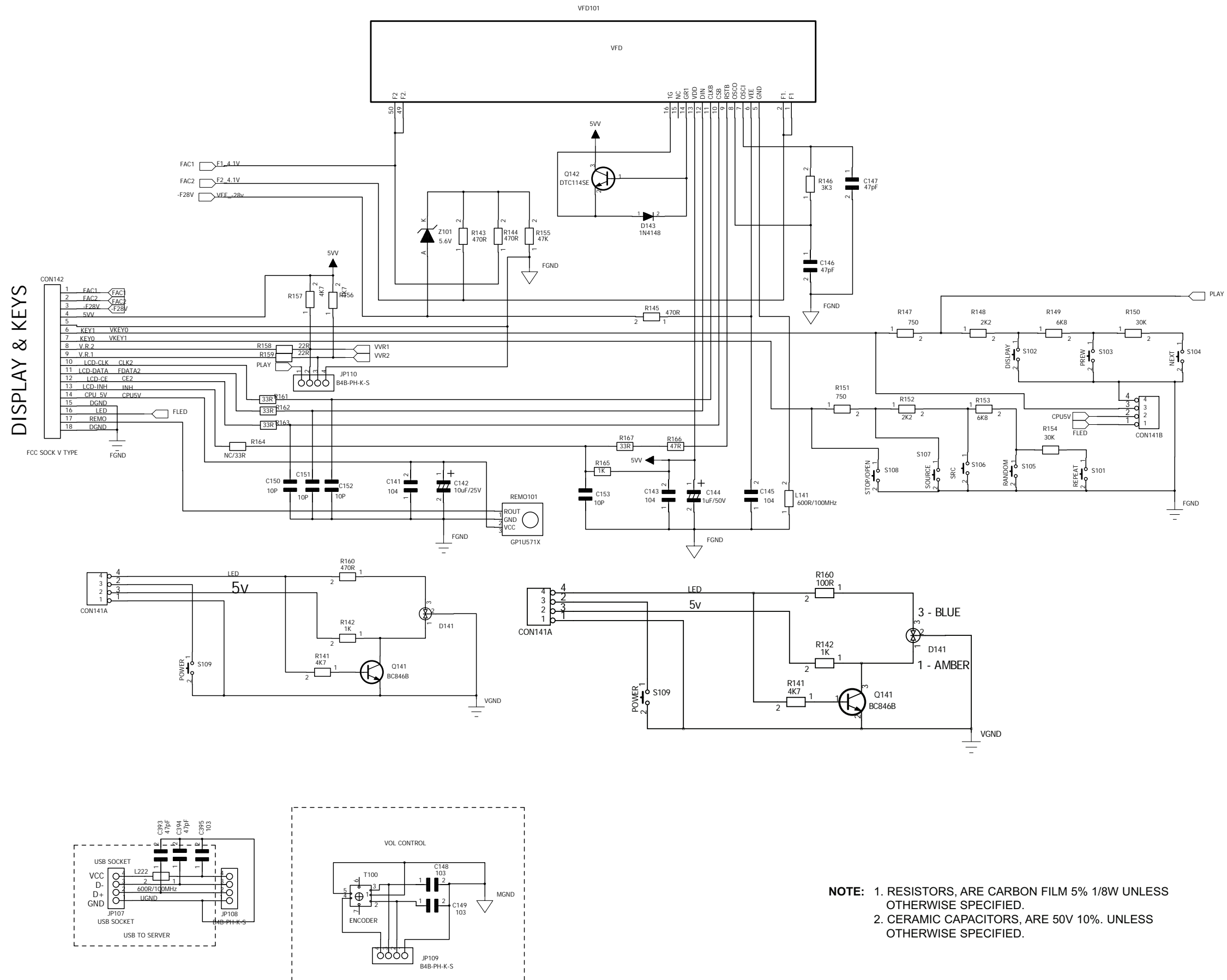

NOTE: 1. RESISTORS, ARE CARBON FILM 5% 1/8W UNLESS OTHERWISE SPECIFIED.
 2. CERAMIC CAPACITORS, ARE 50V 10%. UNLESS OTHERWISE SPECIFIED.

SERVO

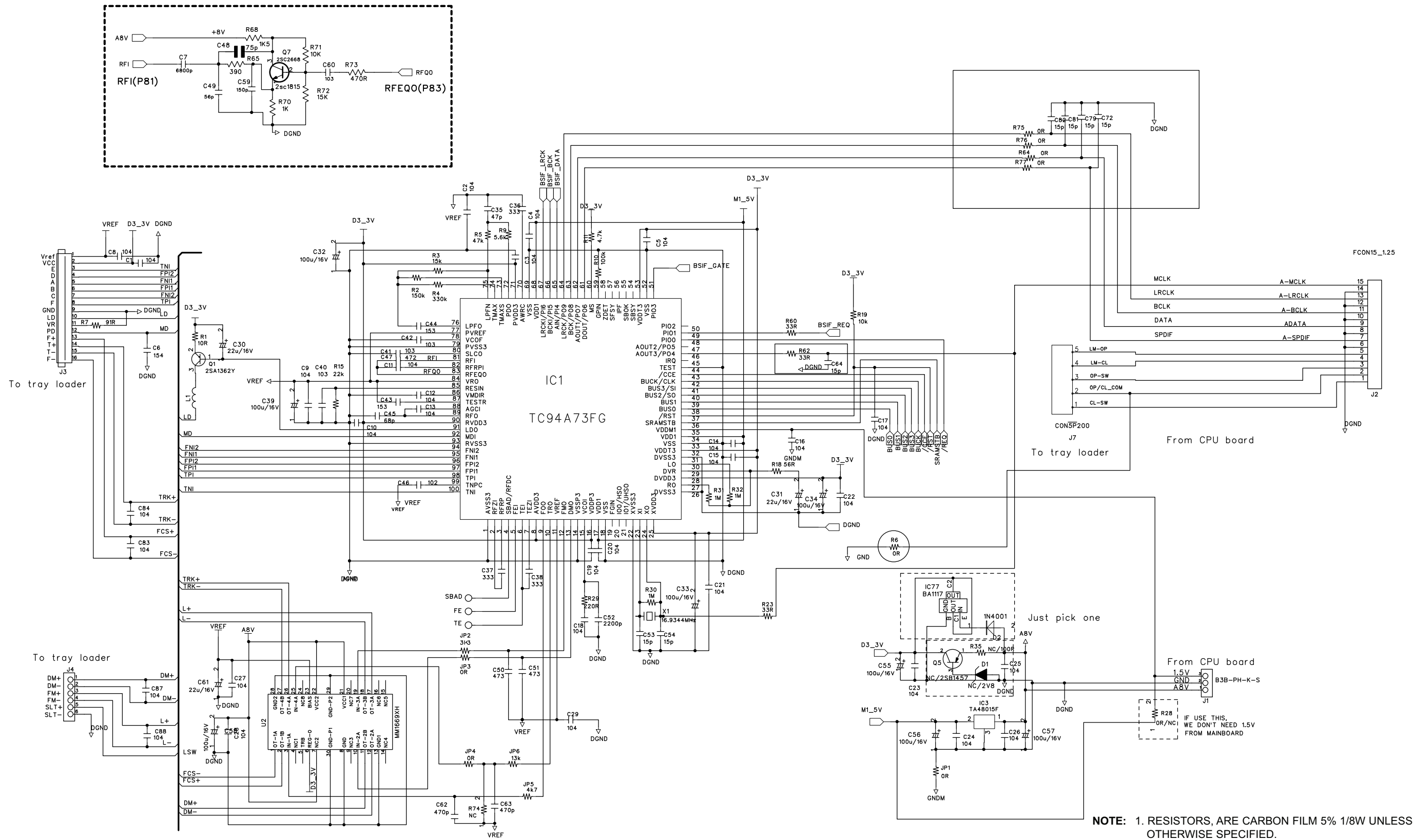

NOTE: 1. RESISTORS, ARE CARBON FILM 5% 1/8W UNLESS OTHERWISE SPECIFIED.
 2. CERAMIC CAPACITORS, ARE 50V 10%. UNLESS OTHERWISE SPECIFIED.

USB

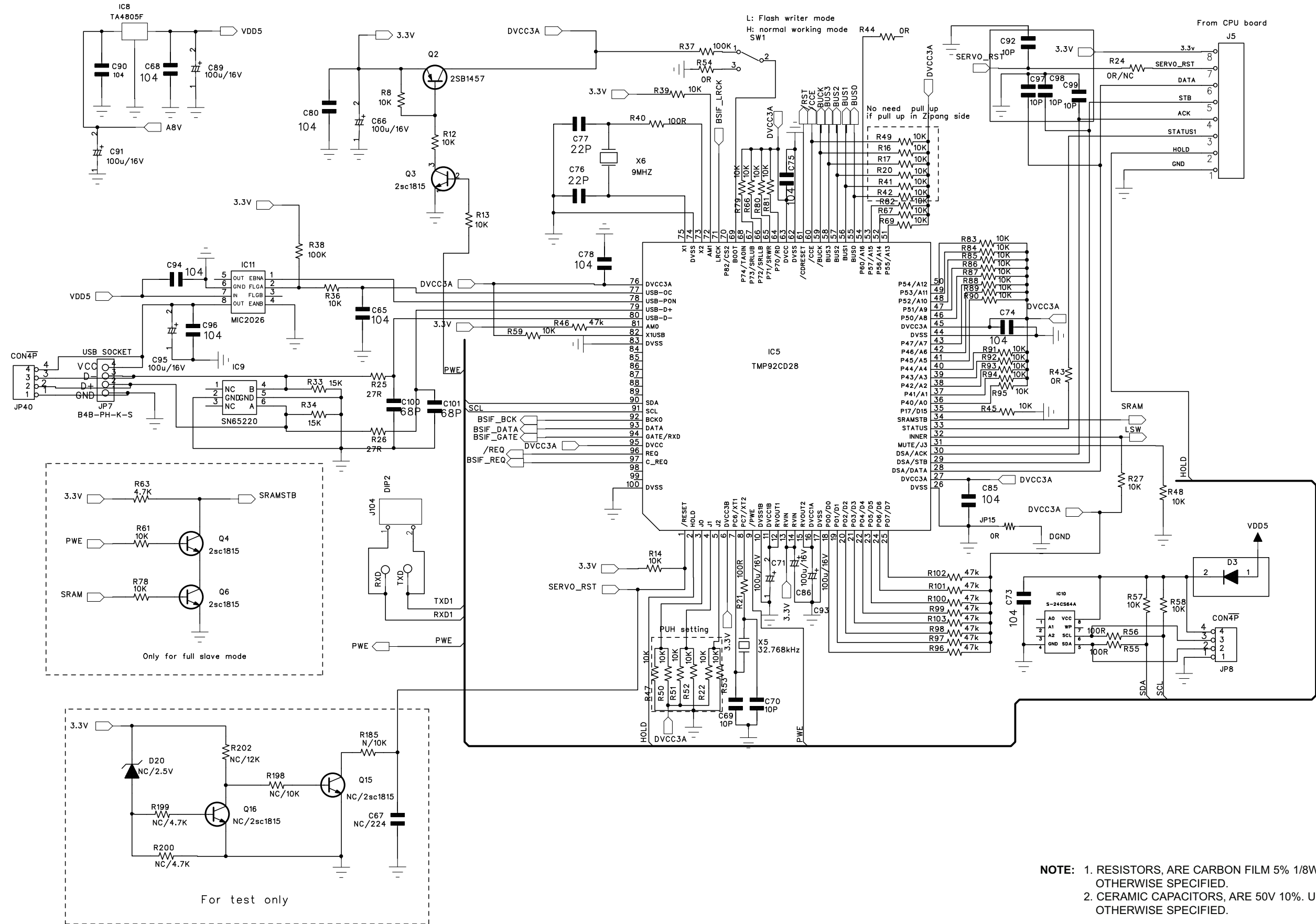

NOTE: 1. RESISTORS, ARE CARBON FILM 5% 1/8W UNLESS OTHERWISE SPECIFIED.
 2. CERAMIC CAPACITORS, ARE 50V 10%. UNLESS OTHERWISE SPECIFIED.

IC BLOCK DIAGRAM

MAIN BOARD

IC200: LM809M3-3.08/NOP

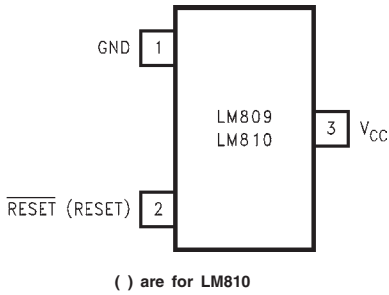

MAIN BOARD

IC202, IC203: REG NCP1117ST33T3G

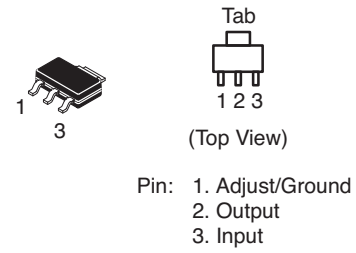

MAIN BOARD

IC201: NVP1117ST18T3G

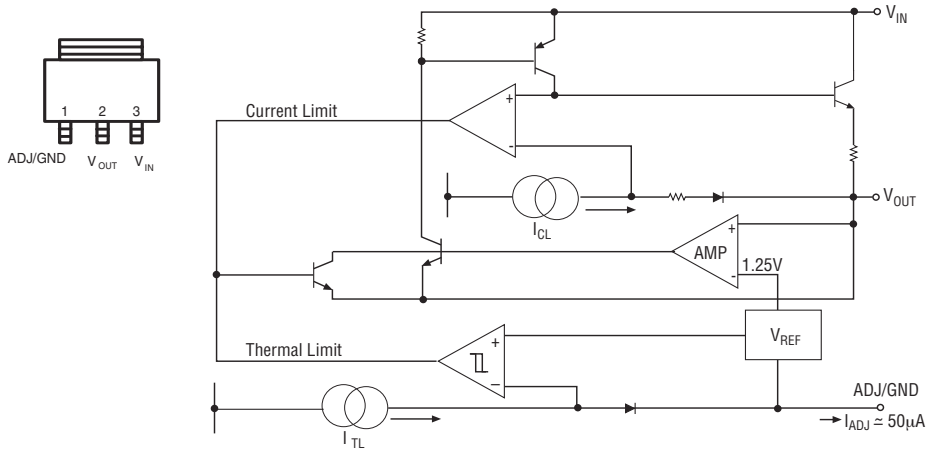

MAIN BOARD

IC204, IC211, U208: NJM7805FA-#ZZZB

U204: NJM7812FA-#ZZZB

U207: 6V 3-TERMINAL REGULATOR 7800FA

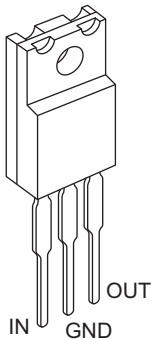

MAIN BOARD

IC212: QUAD 2INPUT EXCLUSIVE

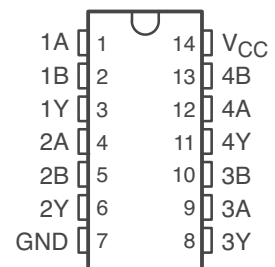

MAIN BOARD

IC205: DSP SRC4382 TDFP-48

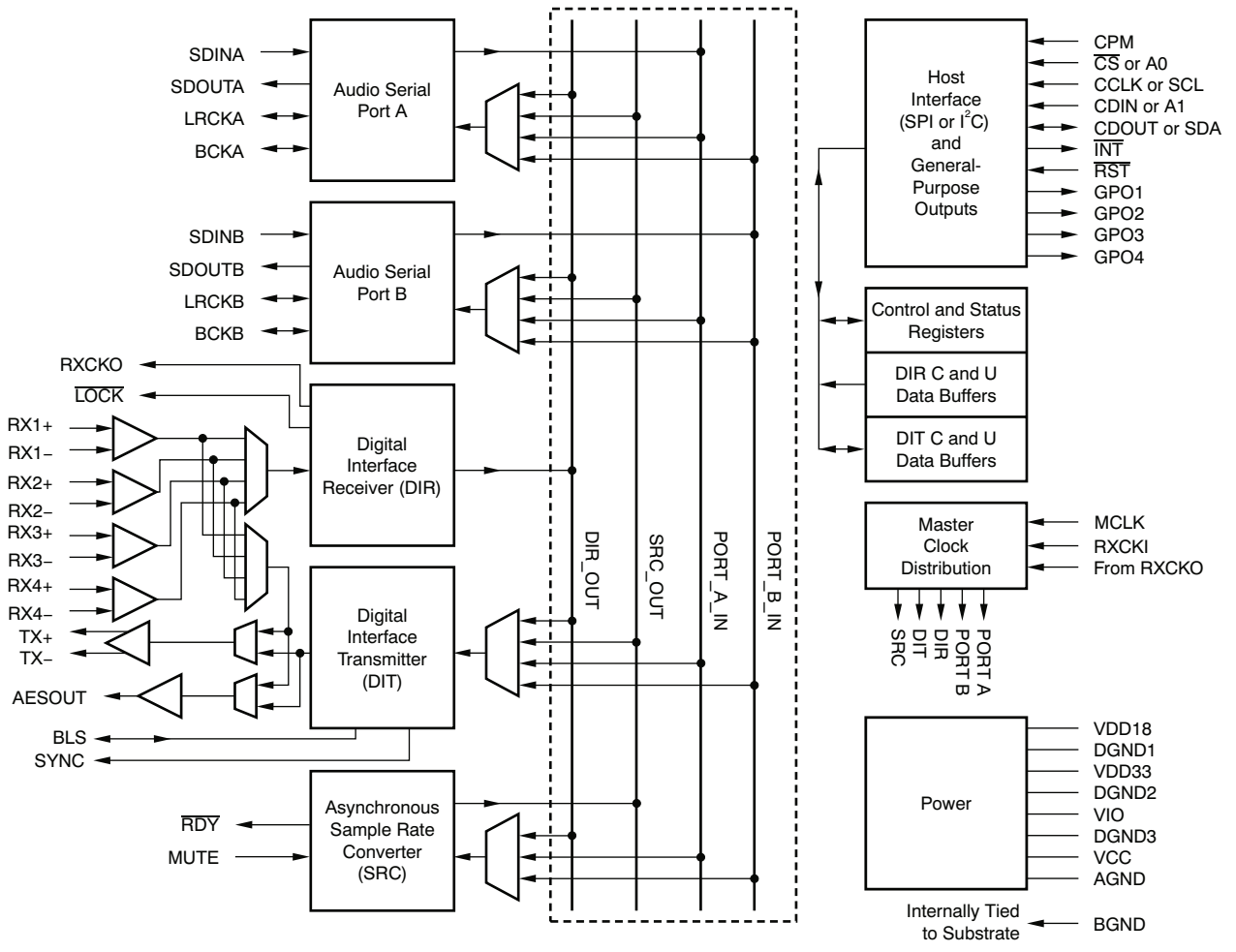
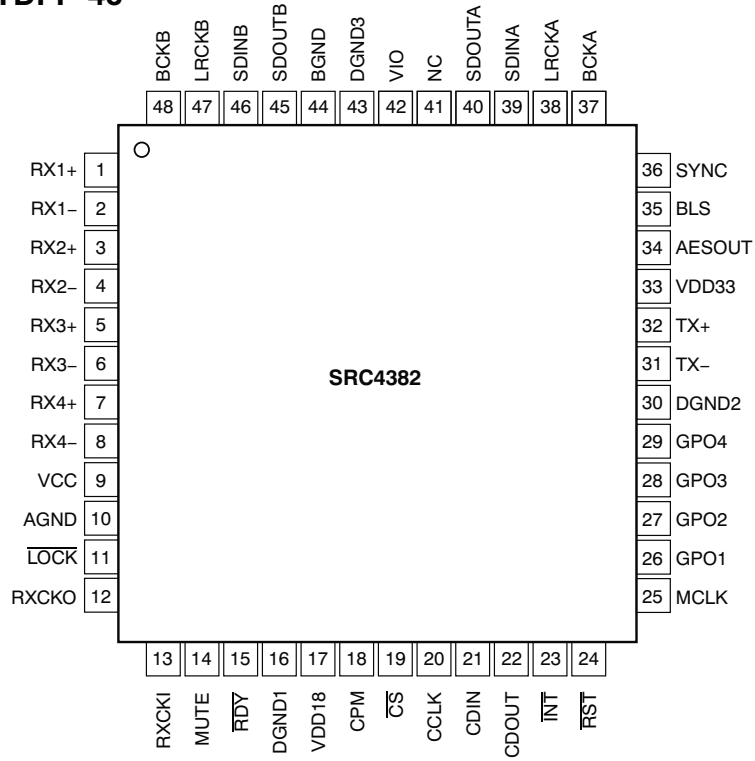

MAIN BOARD

IC206: MCU TMP86FS49AUG

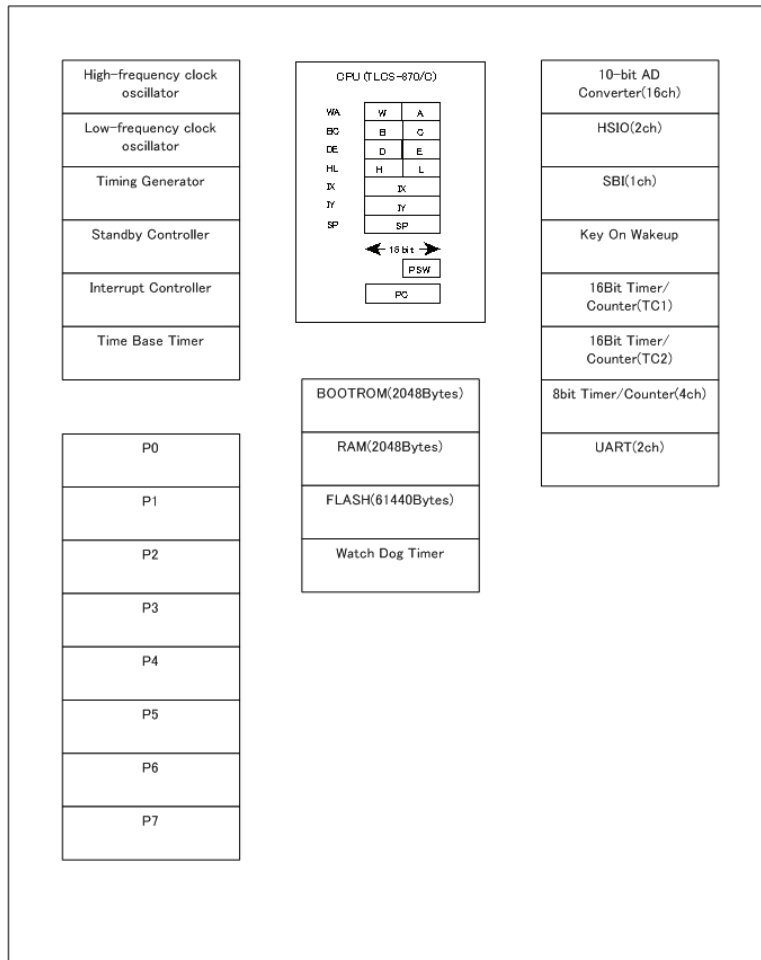
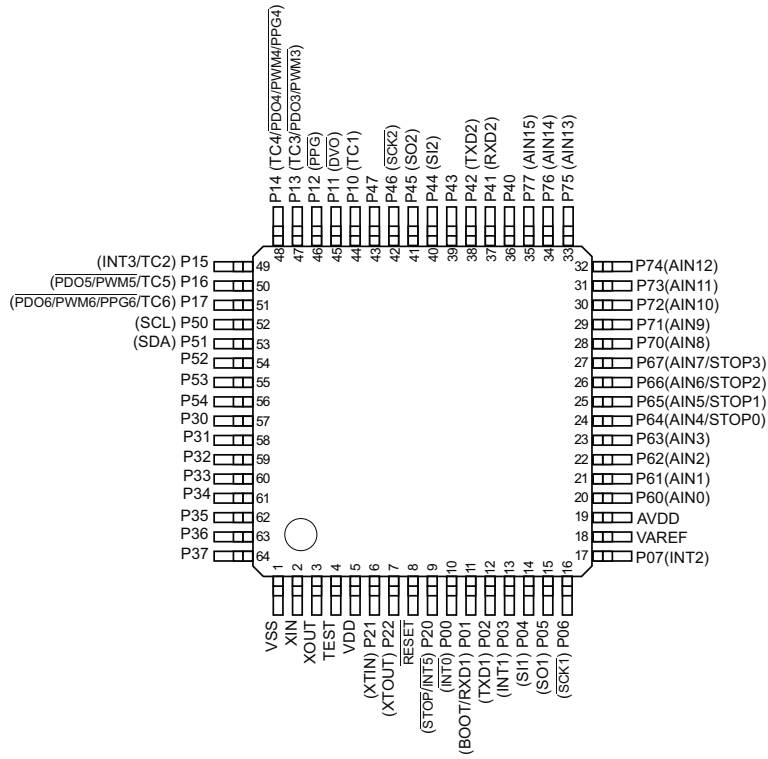

MAIN BOARD

IC207: MEMORY 24C1024 SOIC8

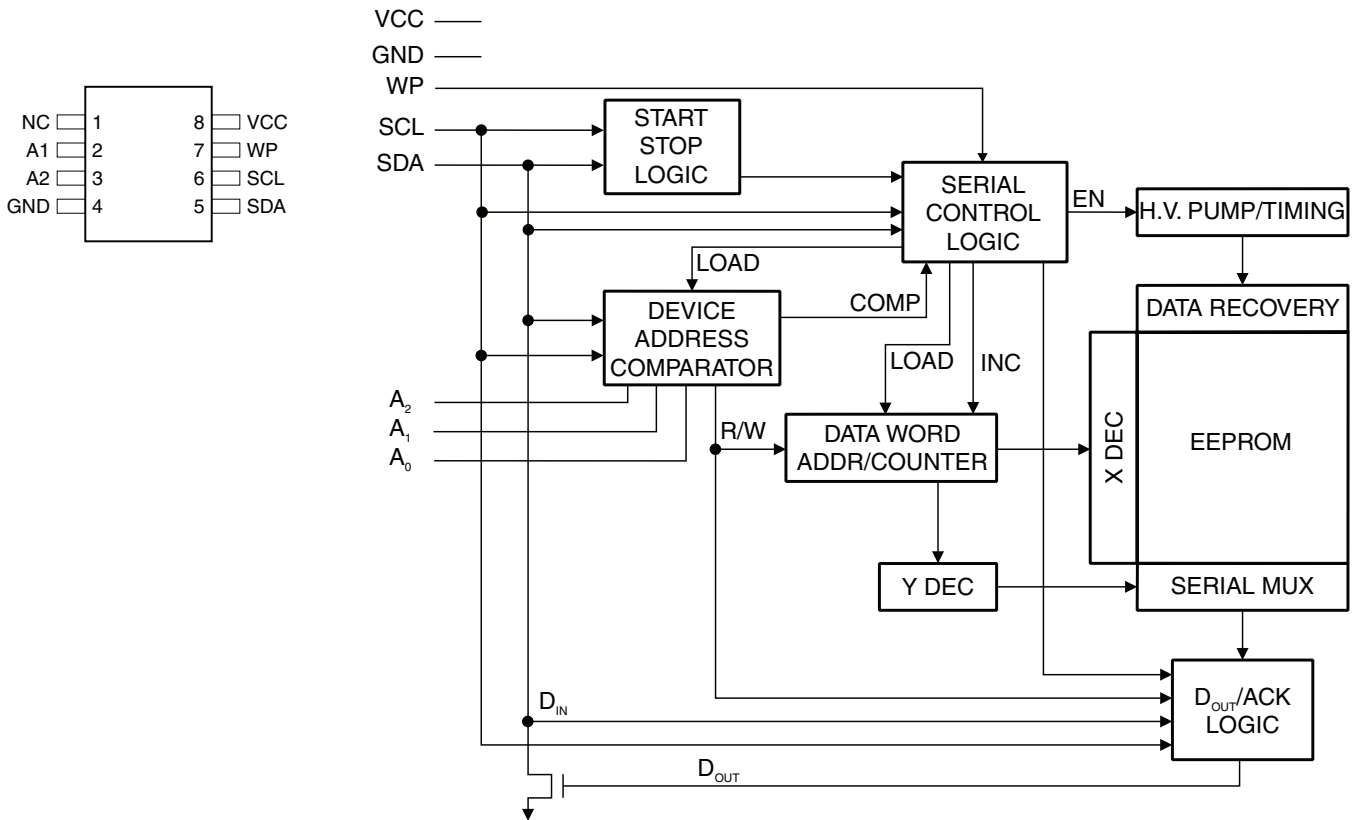

MAIN BOARD

IC209: REGULATOR TA48015F

SERVOR BOARD

IC3: REGULATOR TA48015F

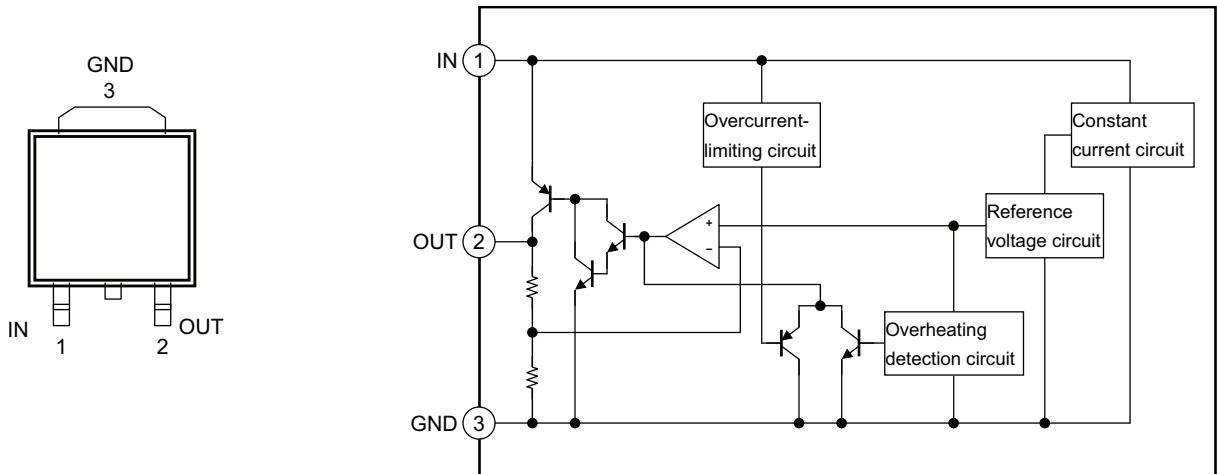

MAIN BOARD

U202: TA7291SG(5/M)22240239

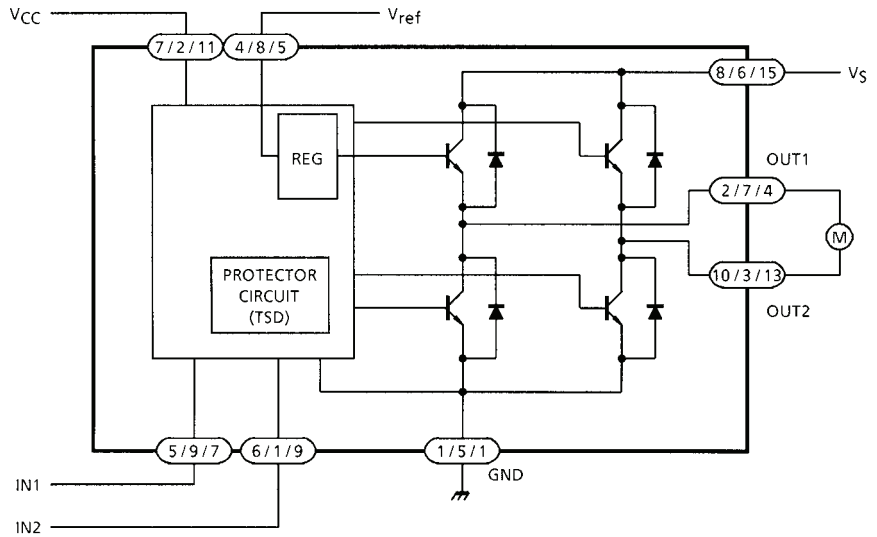
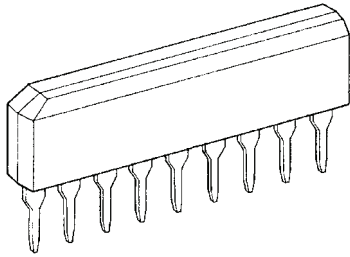

MAIN BOARD

U203: LM393MNOBP

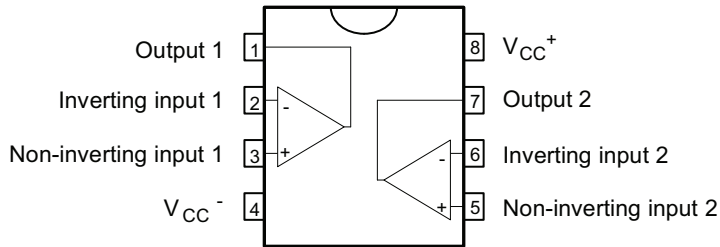

MAIN BOARD

U205: NJM7912FA-#ZZZB

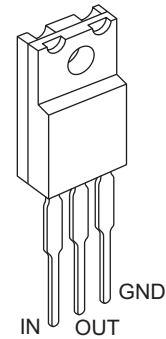

MAIN BOARD

U210: QUAD BUFFER

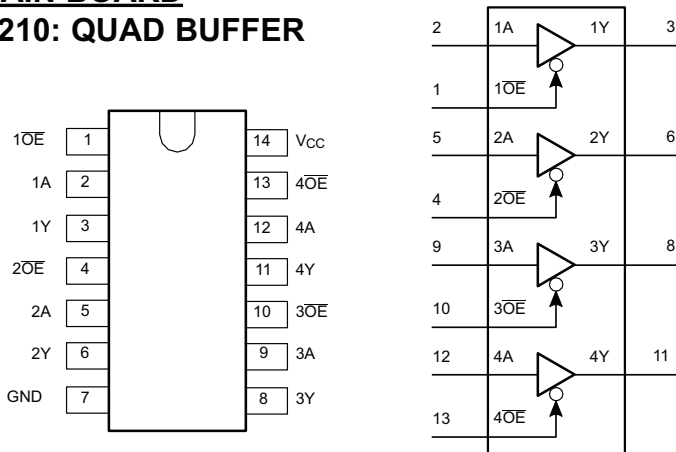

MAIN BOARD

U212, U213: OPA2134UA/2K5

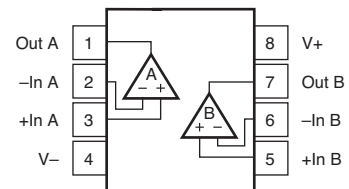

POWER BOARD
D230: ADJUST SHUNT REG

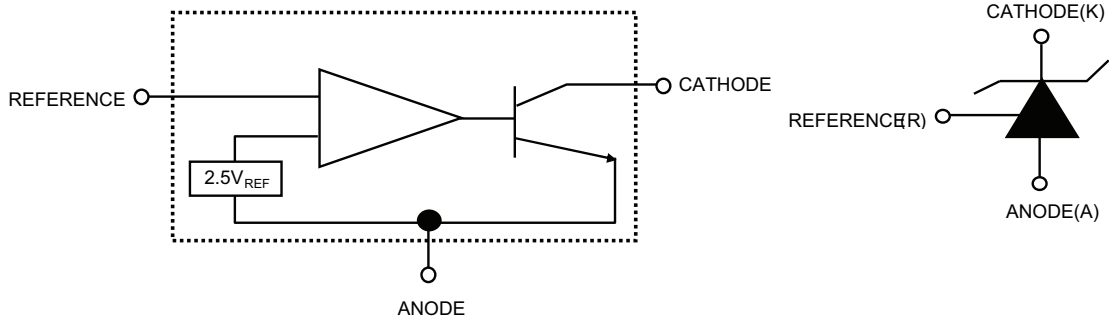

POWER BOARD
U201: POWER NCP1014

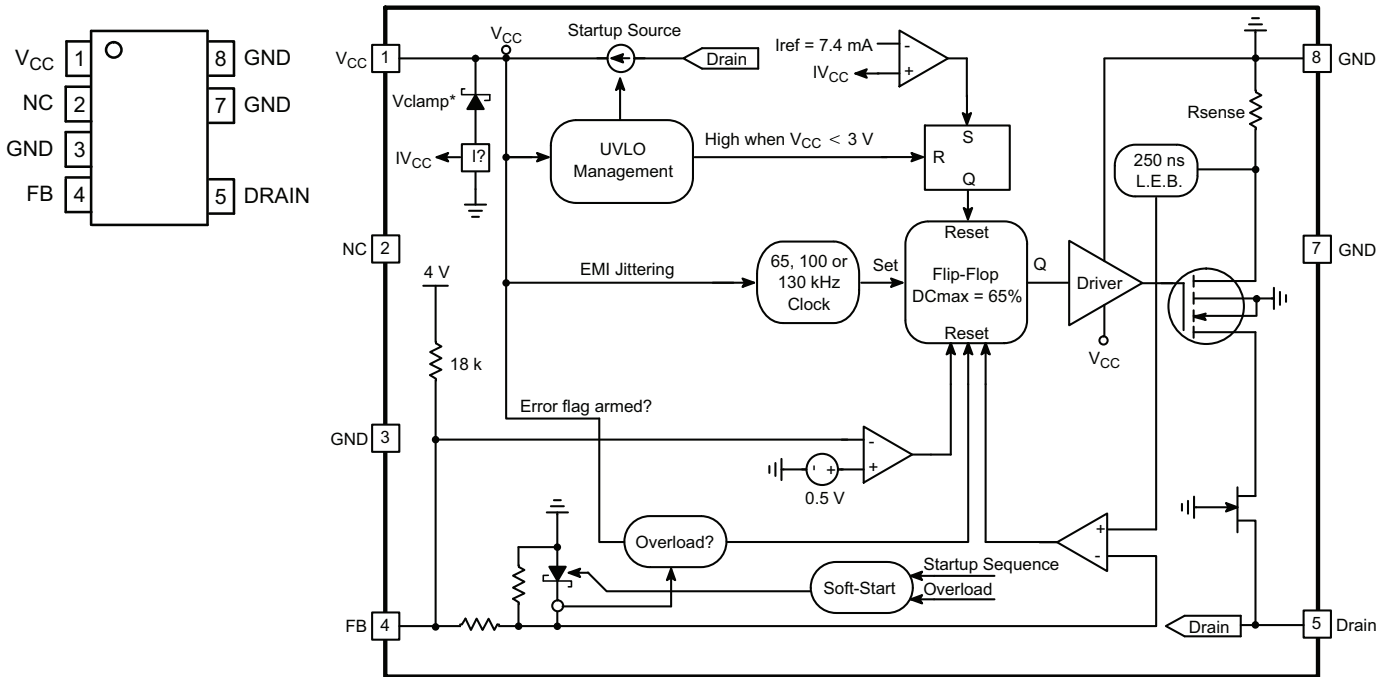

*Vclamp = VCCOFF + 200 mV (8.7 V Typical)

SERVO BOARD

IC1: DSP TC94A73MFG

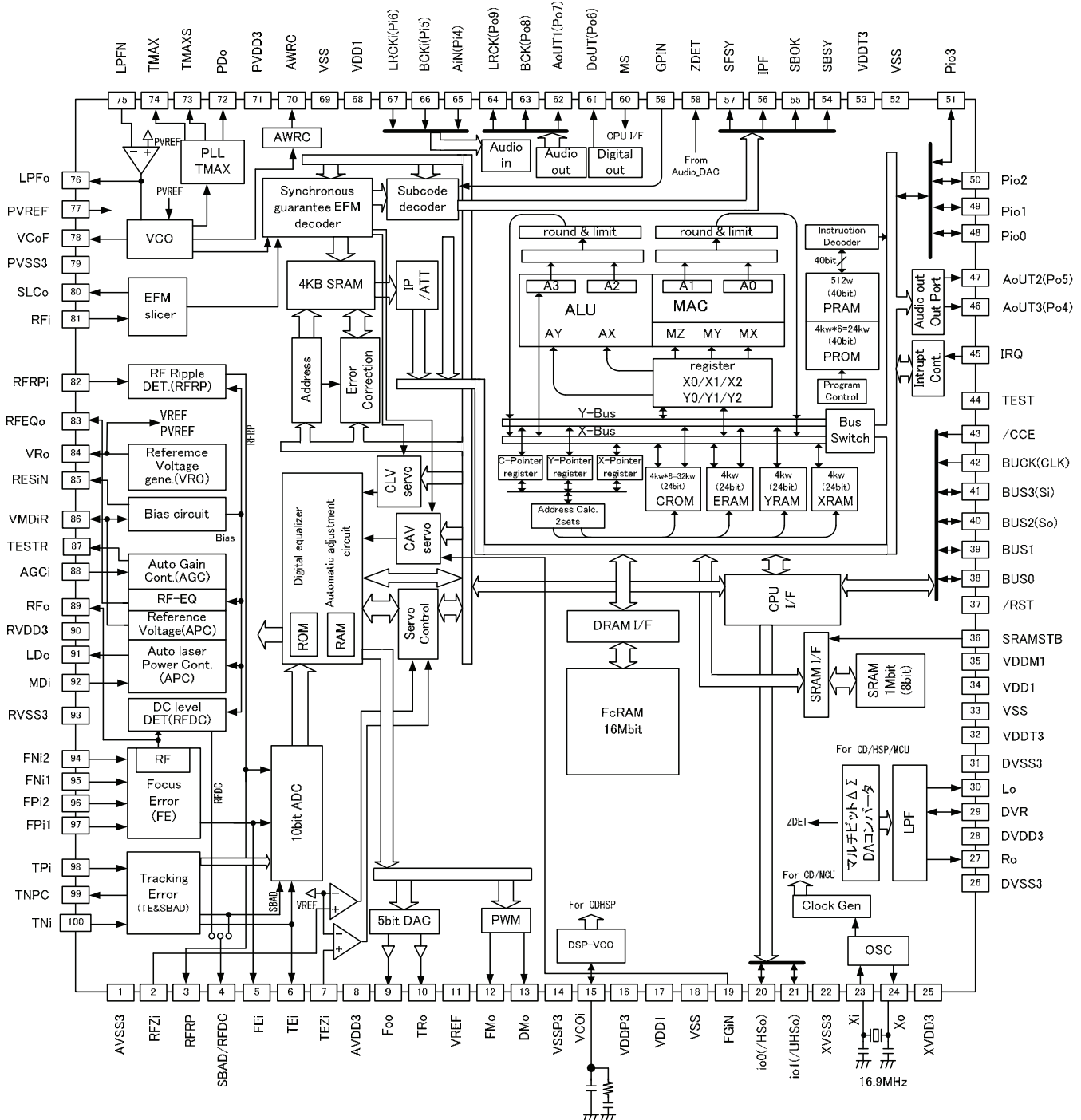
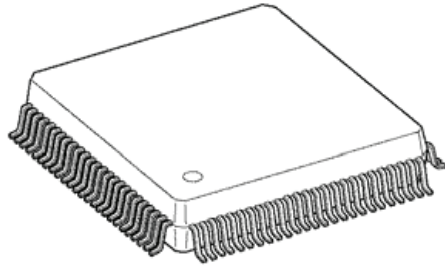

SERVO BOARD

IC5: MCU TMP92FD28A

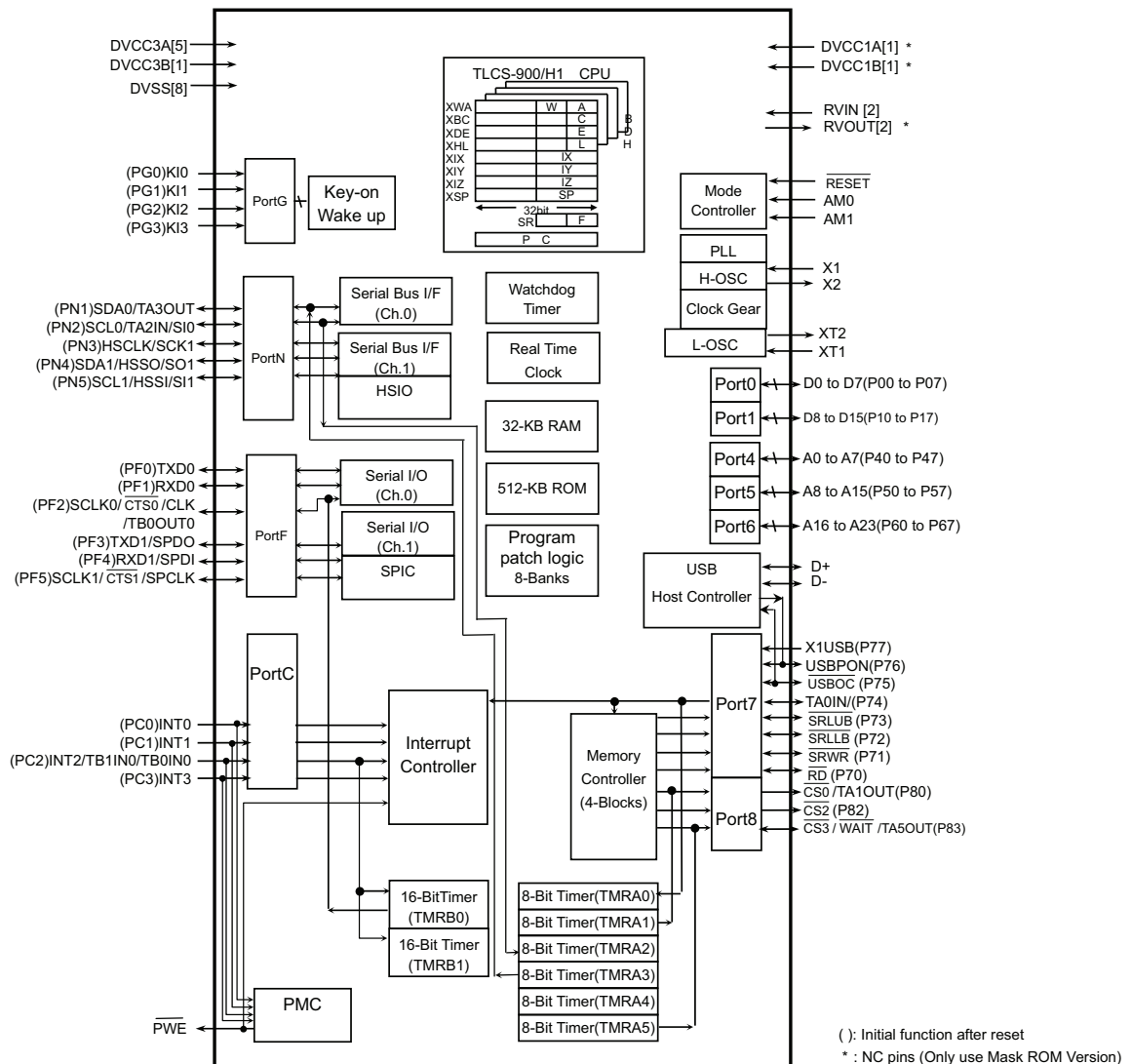
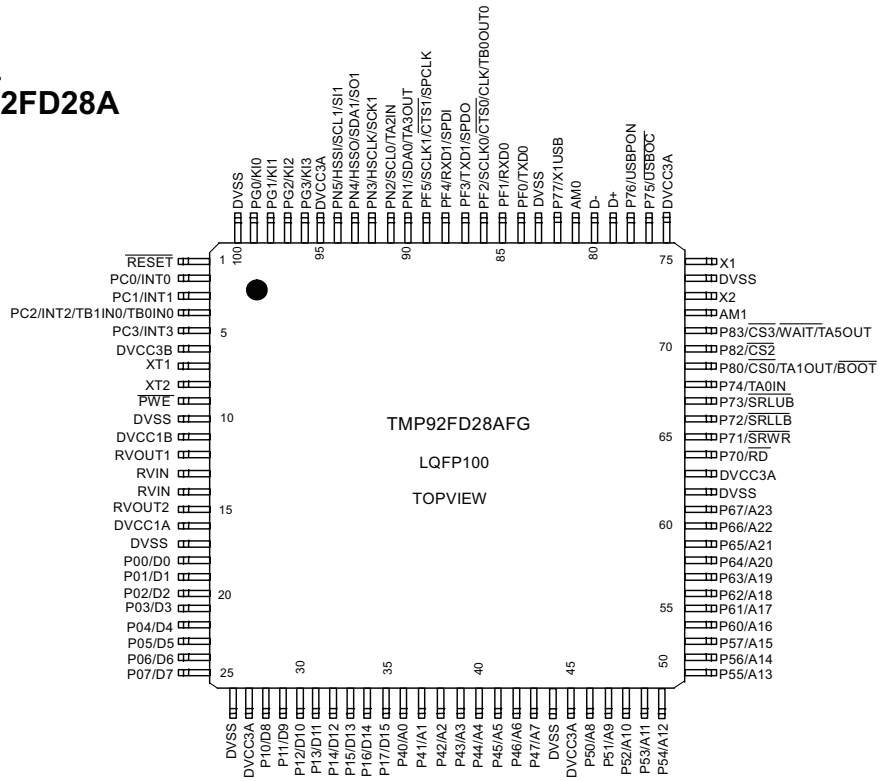

SERVO BOARD

IC8: REGULATOR TA4805F SMD

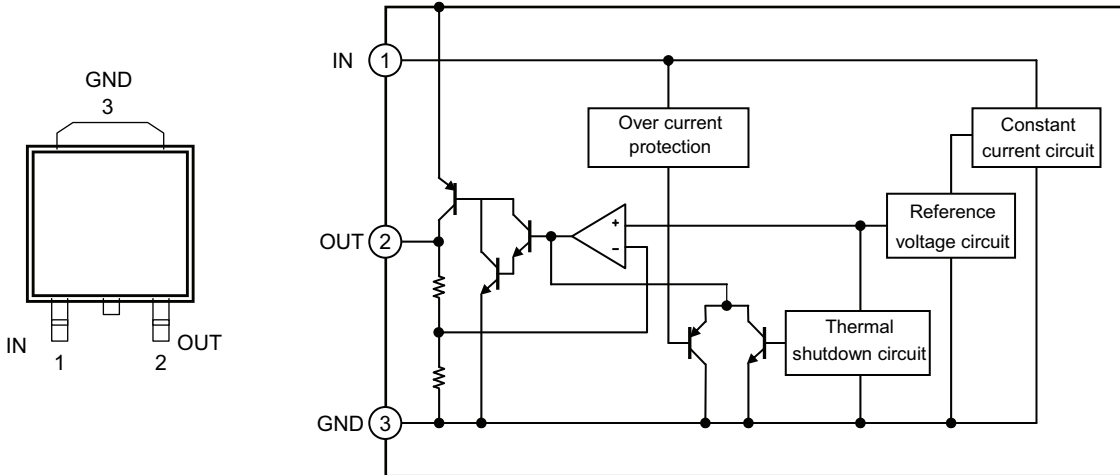

SERVO BOARD

IC10: MEMORY EPROM

A ₀	1	8	V _{CC}
A ₁	2	7	WP
A ₂	3	6	SCL
V _{SS}	4	5	SDA

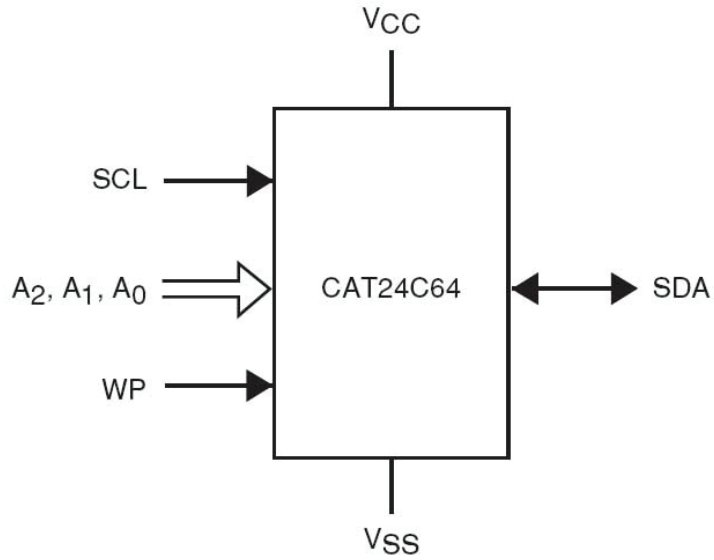

SERVO BOARD

IC77: LM1117S-3.3

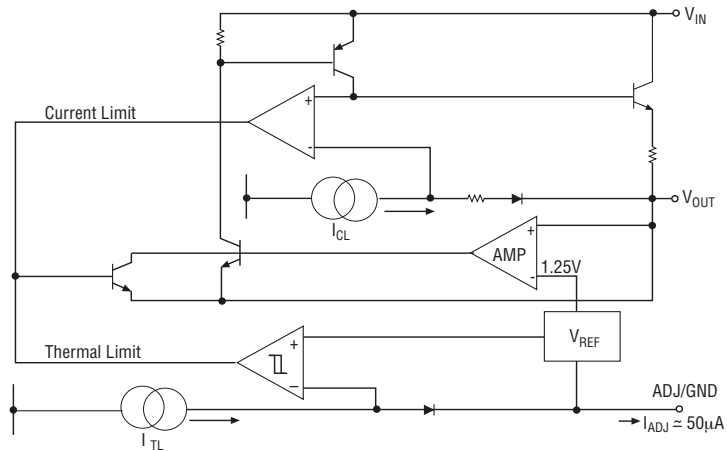
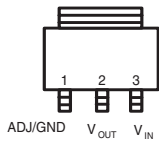

SERVO BOARD

U2: MOTOR DRV W/3.3V REG

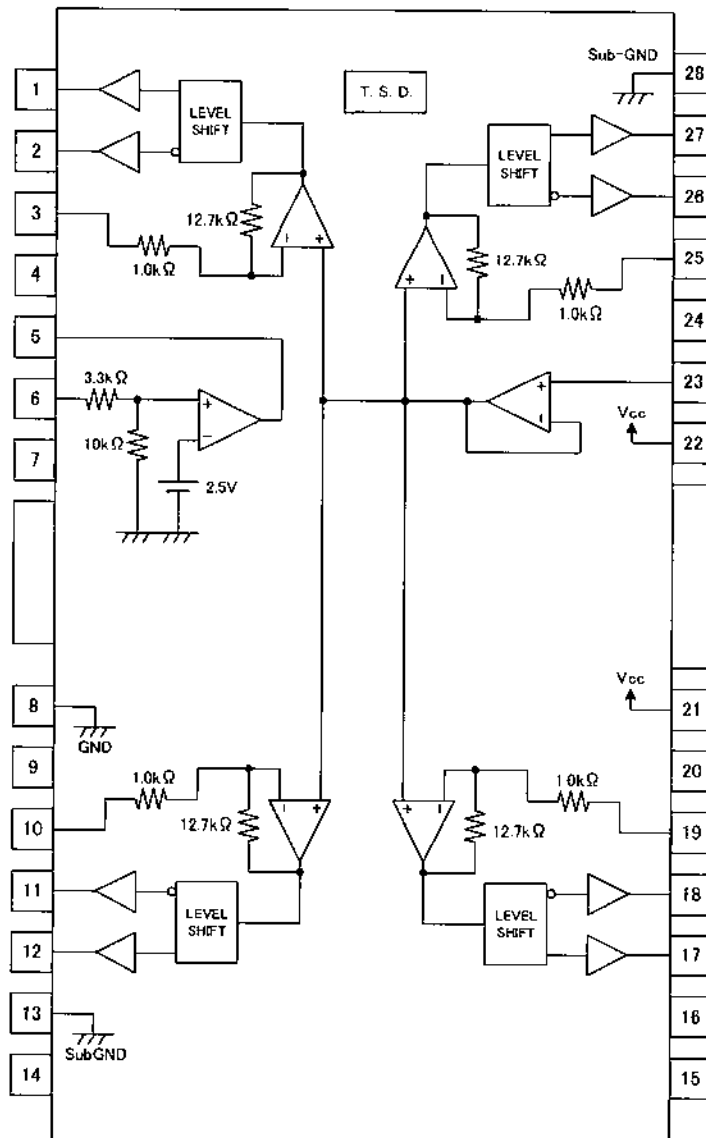
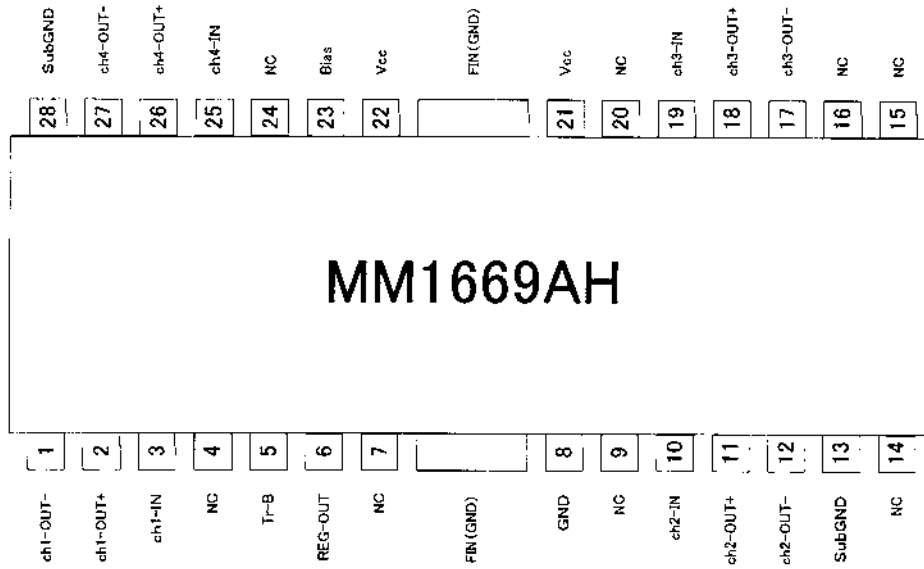

TROUBLESHOOTING GUIDE

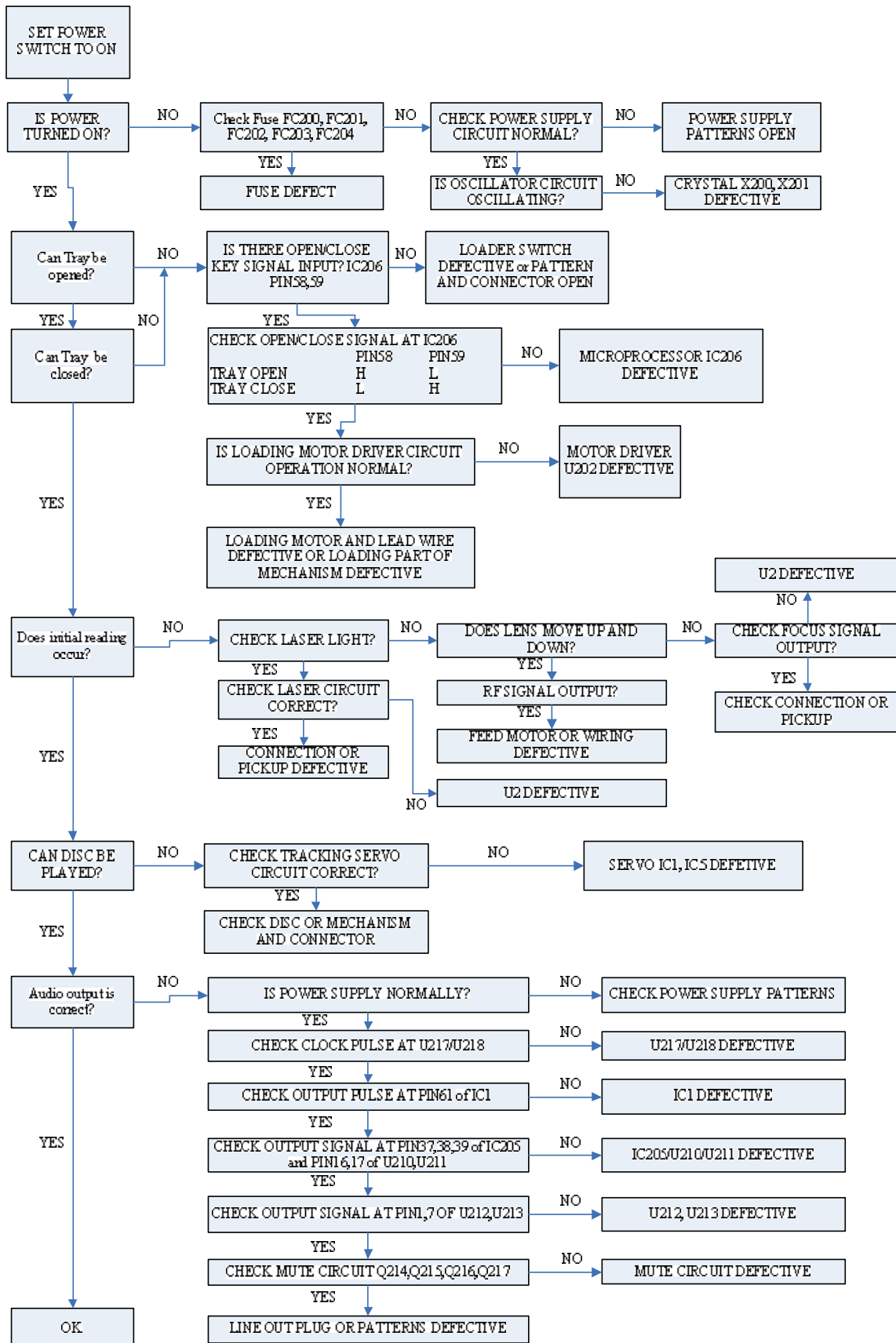

ELECTRICAL PARTS LIST

<u>Location</u>	<u>Part Number</u>	<u>Description</u>
LED ASSY		
E	SVC-C56516+LED	PCB ASSY LED part of fascia
PC BOARD		
E	1725-982A+0001	PCB MAIN/VFD/USB/PWR/VOL D
WAFER/SOCKETS		
CON141A	2102-040R+J01	WAFER 4P P2.0 90DEG
TRANSISTOR		
Q141	4858-46B0+3	TR BC846B SOT23 PHILIPS
RESISTOR		
R141	4723-472A+P	RMG 1/16W 4.7K 1%.
R142	4723-122A+P	RMG 1/16W 1.2K 1% 0603
R160	4723-431A+P	RMG 1/16W 430R 1% 0603
SWITCH		
S109	5200-4905+0	Replaces 5200-4861+0-01 TACT
LED		
D141	3700-2858+AB	LED SP 5X5XL0.5 AM/BU
MAIN ASSY		
A *AH	SVC-C56516+MAIN	PCB ASSY MAIN
A *C	SVC-C56526+MAIN	PCB ASSY MAIN
PC BOARD		
A	1725-982A+0001	PCB MAIN/VFD/USB/PWR/VOL
CAPACITOR		
C200	157D-106M+K-IUE	CE 16V 10U 20% RLT 5X11
C201	150F-104K+P-AC	CC 50V 0.1uF 10%
C202	150F-104J+P-AC	CC 50V 0.1U 5% 0603
C203	150F-104K+P-AC	CC 50V 0.1uF 10%
C204, C205	157D-106M+K-IUE	CE 16V 10U 20% RLT 5X11
C206	150F-104K+P-AC	CC 50V 0.1uF 10%

<u>Location</u>	<u>Part Number</u>	<u>Description</u>
C207	157D-107M+K-IUE	CE 16V 100U 20% RLT 5X11
C208, C209	150F-104K+P-AC	CC 50V 0.1uF 10%
C210	157D-476M+K-IME	CE 16V 47U 20% RLT 5X7
C211, C212, C213, C214	157D-106M+5-IUF3	CE 16V 10uF 20% RL 5X11
C215, C216	150F-104K+P-AC	CC 50V 0.1uF 10%
C217	157D-107M+K-IUE	CE 16V 100U 20% RLT 5X11
C218, C219	150F-104K+P-AC	CC 50V 0.1uF 10%
C220	157D-477M+K-OVE	CE 16V 470U 20% RLT
C221, C222	157D-106M+5-IUF3	CE 16V 10uF 20% RL 5X11
C223, C224, C225, C226, C227, C228, C229, C231, C234, C238	150F-104K+P-AC	CC 50V 0.1uF 10%
C239	157D-107M+K-IUE	CE 16V 100U 20% RLT 5X11
C240, C241	150F-104K+P-AC	CC 50V 0.1uF 10%
C242	157D-477M+K-OVE	CE 16V 470U 20% RLT
C243	15CH-681J+P-AC	CTC 0/60 680PF 5% 0603
C244	150F-103J+P-AC	CC 50V 0.01U 5% 0603
C245	157E-106M+K-IUE	CE 25V 10U 20% RLT P5.0
C246	150F-104K+P-AC	CC 50V 0.1uF 10%
C247	150F-102J+P-AC	CC 50V 1000P 5% 0603 X7R
C248	150F-104K+P-AC	CC 50V 0.1uF 10%
C249	157E-108M+K-X9TU	CE 25V 1000U 20% RLT
C250	150H-104K+P-AC	CC 100V 0.1U 10% 0603
C251	150F-104K+P-AC	CC 50V 0.1uF 10%
C252	150T-222M+5-SK	CC 400V 2200P 20% RL
C253	157E-108M+K-X9TU	CE 25V 1000U 20% RLT
C254	150F-104K+P-AC	CC 50V 0.1uF 10%
C255	157E-477M+K-S5TU	CE 25V 470U 20% RLT
C256	150F-104K+P-AC	CC 50V 0.1uF 10%
C257, C258	157E-477M+K-S5TU	CE 25V 470U 20% RLT
C259	150F-104K+P-AC	CC 50V 0.1uF 10%
C260	157D-228M+5-X&TU	CE 16V 2200U 20% RL
C261, C262	150F-104K+P-AC	CC 50V 0.1uF 10%
C263	157E-478M+5-7^TU	CE 25V 4700U 20% RL
C264	150F-104K+P-AC	CC 50V 0.1uF 10%
C265	157D-108M+K-S9TU	CE 16V 1000U 20% RLT
C266	150F-104K+P-AC	CC 50V 0.1uF 10%
C267	157E-477M+K-S5TU	CE 25V 470U 20% RLT
C268	150F-104K+P-AC	CC 50V 0.1uF 10%
C269	157E-227M+K-OVRT	CE 25V 220U 20%RLT8X11.5
C270	150F-104K+P-AC	CC 50V 0.1uF 10%
C271	157E-477M+K-S5TU	CE 25V 470U 20% RLT
C272	150F-104K+P-AC	CC 50V 0.1uF 10%
C273	157E-227M+K-OVRT	CE 25V 220U 20%RLT8X11.5
C274	157I-107M+5-SX	CE 63V 100uF 20% RL

<u>Location</u>	<u>Part Number</u>	<u>Description</u>
C275	157F-476M+K-LUTI	CE 50V 47U 20% RLT
C276	150F-104K+P-AC	CC 50V 0.1uF 10%
C277	157F-476M+K-LUTI	CE 50V 47U 20% RLT
C278, C279, C280, C281	150F-104K+P-AC	CC 50V 0.1uF 10%
C282	157D-106M+K-IUE	CE 16V 10U 20% RLT 5X11
C283	150F-104K+P-AC	CC 50V 0.1uF 10%
C284	157D-106M+K-IUE	CE 16V 10U 20% RLT 5X11
C285, C286	150F-104K+P-AC	CC 50V 0.1uF 10%
C287	157D-106M+K-IUE	CE 16V 10U 20% RLT 5X11
C288, C289	150F-104K+P-AC	CC 50V 0.1uF 10%
C290	157D-106M+K-IUE	CE 16V 10U 20% RLT 5X11
C291	150F-103J+P-AC	CC 50V 0.01U 5% 0603
C293	150F-104K+P-AC	CC 50V 0.1uF 10%
C294	157D-106M+K-IUE	CE 16V 10U 20% RLT 5X11
C295	150F-104K+P-AC	CC 50V 0.1uF 10%
C296	157D-106M+K-IUE	CE 16V 10U 20% RLT 5X11
C297	150F-104K+P-AC	CC 50V 0.1uF 10%
C298	157D-108M+K-S9TU	CE 16V 1000U 20% RLT
C299	157D-476M+K-IM	CE 16V 47U 20% RLT 5X7
C300, C301, C302, C303, C304, C305	157D-106M+5-IUF3	CE 16V 10uF 20% RL 5X11
C306, C307, C308, C309	157D-227M+K-LUE	CE 16V 220U 20% RLT 6.3X
C310	150F-104K+P-AC	CC 50V 0.1uF 10%
C311, C312	15CH-101J+P-AC	CTC 0/60 100pF 5% 0603
C313	157D-107M+K-LUNU	CE 16V 100U 20% RLT 6.3
C314, C315	150F-104K+P-AC	CC 50V 0.1uF 10%
C316, C317, C318	150F-103J+P-AC	CC 50V 0.01U 5% 0603
C319, C320	15CH-101J+P-AC	CTC 0/60 100pF 5% 0603
C321	157D-107M+K-LUNU	CE 16V 100U 20% RLT 6.3
C322, C323, C324, C325, C326, C327, C328, C329, C330	150F-104K+P-AC	CC 50V 0.1uF 10%
C332	15CH-102J+P-AC	CTC 0/60 1000P 5% 0603
C333	15CH-151J+P-AC	CTC 0/60 150pF 5% 0603
C334	150F-104K+P-AC	CC 50V 0.1uF 10%
C335	15CH-151J+P-AC	CTC 0/60 150pF 5% 0603
C336	15CH-102J+P-AC	CTC 0/60 1000P 5% 0603
C337	150F-103J+P-AC	CC 50V 0.01U 5% 0603
C338, C339	150F-104K+P-AC	CC 50V 0.1uF 10%
C341	15CH-102J+P-AC	CTC 0/60 1000P 5% 0603
C342, C343	15CH-151J+P-AC	CTC 0/60 150pF 5% 0603
C344	15CH-102J+P-AC	CTC 0/60 1000P 5% 0603
C345	150F-104K+P-AC	CC 50V 0.1uF 10%
C346	150F-103J+P-AC	CC 50V 0.01U 5% 0603
C347	150F-104K+P-AC	CC 50V 0.1uF 10%
C348	157D-107M+K-IUE	CE 16V 100U 20% RLT 5X11

<u>Location</u>	<u>Part Number</u>	<u>Description</u>
C349	150F-104K+P-AC	CC 50V 0.1uF 10%
C350	157D-108M+K-S9TU	CE 16V 1000U 20% RLT
C351	150F-104K+P-AC	CC 50V 0.1uF 10%
C352	157D-108M+K-S9TU	CE 16V 1000U 20% RLT
C353	150F-103J+P-AC	CC 50V 0.01U 5% 0603
C354	157D-107M+K-IUE	CE 16V 100U 20% RLT 5X11
C355, C356, C357, C358	15CH-220J+P-AC	CTC 0/60 22pF 5% 0603
C359	157D-107M+K-IUE	CE 16V 100U 20% RLT 5X11
C360, C361, C362, C363	150F-104K+P-AC	CC 50V 0.1uF 10%
C365	157E-106M+K-IUE	CE 25V 10U 20% RLT P5.0
C370, C371, C372, C373	150F-104K+P-AC	CC 50V 0.1uF 10%
C374	15CH-270J+P-AC	CTC 0/60 27PF 5% 0603
C375	150F-104K+P-AC	CC 50V 0.1uF 10%
C376	157D-107M+K-IUE	CE 16V 100U 20% RLT 5X11
C377	150F-104K+P-AC	CC 50V 0.1uF 10%
C378	157D-107M+K-IUE	CE 16V 100U 20% RLT 5X11
C379, C380	150F-104K+P-AC	CC 50V 0.1uF 10%
C381	157F-105M+K-GM	CE 50V 1U 20% RLT 4X7
C382	150F-104K+P-AC	CC 50V 0.1uF 10%
C383, C384	150F-471J+P-AC	CC 50V 470P 5% 0603
C385	157D-106M+K-IUE	CE 16V 10U 20% RLT 5X11
C387	150F-104K+P-AC	CC 50V 0.1uF 10%
C389, C390	153H-224K+9-NNMJ	CM 100V 0.22U 10% RB
C391	150F-473K+P-AC	CC 50V 0.047uF 10% 0603
C398TE	150F-104K+J-BD	CC 50V 0.1uF 10% 0805
C399	157E-106M+K-IUE	CE 25V 10U 20% RLT P5.0
DIODE		
D200, D201, D202	4801-48W0+3	DIODE 1N4148W SOD-123
D212	4837-4V76+2	DZ 1/2W 4.7V TEMIC AT
D213	4840-0490+0	BRIDGE RECTIFIER RB152-B
D214	4840-0630+0	BRIDGE DIODE 2W02G
D216	4804-0010+2	DIODE W1N4001-A(WA) AT
D217	4840-0490+0	BRIDGE RECTIFIER RB152-B
D218	4804-0030+2	DIODE IN4003-F AT
D219	4837-30V6+2	DZ 1/2W 30V 5% TEMIC AT
D220, D223, D224	4801-48W0+3	DIODE 1N4148W SOD-123
D225, D226	480T-54S0+3	DOUBLE DIODE BAT54S
D227	4804-0010+2	DIODE W1N4001-A(WA) AT
D228	4801-48W0+3	DIODE 1N4148W SOD-123
D232	4804-0020+5	DIODE UF4002 RL D0-41
R290TE	4804-1480+3	DIODE LL4148 SM
U216	4802-02K0+3	DIODE SW 80V 300MA

<u>Location</u>	<u>Part Number</u>	<u>Description</u>
<i>WAFER/SOCKET</i>		
AC201	2101-1432+0	WAFER 2P P7.92 JAPAN
J200	2101-9400+0	JM2422-3M WAFER
J203	2101-3149+0	CONNECTOR FFC 15P P1.25
J209	2102-040S+003	WAFER 4P P2.0 STRAIGHT
J210	2102-030S+003	3P ST.WAFER P=2.0
J211	2102-080S+003	8P ST. WAFER P=2.0
JP222	2102-040S+003	WAFER 4P P2.0 STRAIGHT
SW200	2101-1495+0	WAFER 3PIN P=2.54 ST 6MM
<i>JACK/SOCKET</i>		
J300	2113-2036+0	PHONE JACK D315 BK
RCA201	2113-3203+0	SOCKET RCA COAXAL
<i>COIL</i>		
D210	1808-0680+0	FERRITE BEAD INDUCTOR
L211	1807-100Q+P	FERRITE COIL 10UH 15%
L217	1801-330K+M	INDUCTOR 33UH EC24 10%
<i>CRYSTAL</i>		
U217	2300-3323+0	CRYSTAL 24.576MHZ
U218	2300-3324+0	CRYSTAL 22.5792MHZ
X200	2300-2990+0	X'TAL 8MHZ HC-49/U-S
X201	2300-3306+0	CRYSTAL QUARTZ 32.768KHZ
<i>RELAY</i>		
RL201	4500-0753+0	RELAY 5VDC 1A DPDT BP-5
RL202	4500-0762+0	RELAY 5VDC 10A SPDT
<i>TRANSISTOR</i>		
Q200, Q201, Q202	4858-46B0+3	TR BC846B SOT23 PHILIPS
Q203	4858-56B0+3	TR BC856B SOT23 PHILIPS
Q204, Q205	4858-46B0+3	TR BC846B SOT23 PHILIPS
Q207	4858-56B0+3	TR BC856B SOT23 PHILIPS
Q209, Q210, Q211	4858-46B0+3	TR BC846B SOT23 PHILIPS
Q212	4851-4570+5	TR PNP 2SB1457 TO-92 RL
Q213	4858-46B0+3	TR BC846B SOT23 PHILIPS
Q218	485B-9080+3	TR PNP 2SB908 2000
Q219, Q220, Q221, Q222, Q223	4858-46B0+3	TR BC846B SOT23 PHILIPS
U206	4860-8050+0	REG NJM7809FA-#ZZZB

<u>Location</u>	<u>Part Number</u>	<u>Description</u>
RESISTOR		
R210, R276, R317, R319, R322, R423, R455, R456, R457, R463, R474	4723-000J+P-R	RMG 1/16W 0R 5% 0603
R203, R208, R209, R214, R215, R220, R221, R222, R223, R226, R232, R238, R239, R240, R241, R242, R243, R244, R247, R250, R251, R252, R253, R263, R271, R279, R283, R287, R288, R289, R295, R296, R297, R332, R342, R343, R344, R345, R346, R349, R350, R351, R352, R353, R358, R362, R363, R364, R365, R378, R395, R400, R431, R462, R480	4723-103A+P-R	RMG 1/16W 10K 1% 0603
R333, R337, R354, R357, R367, R368	4723-104A+P-R	RMG 1/16W 100K 1% 0603
R323, R324	4723-151A+P-R	RMG 1/16W 150R 1% 0603
R284, R286	4723-182A+P-R	RMG 1/16W 1.8K 1% 0603
R383, R384, R389, R390	4723-332A+P-R	RMG 1/16W 3.3K 1% 0603
R336	4723-471A+P-R	RMG 1/16W 470R 1% 0603
R299, R347, R401, R402	4723-473A+P-R	RMG 1/16W 47K 1% 0603
R359	4723-563A+P-R	RMG 1/16W 56K 1% 0603
C247TE	4723-104A+P-R	RMG 1/16W 100K 1% 0603
R204, R205, R206, R207	4723-220A+P	RMG 1/16W 22R 1% 0603
R212	4723-100A+P-R	RMG 1/16W 10R 1% 0603
R217, R218, R219	4723-220A+P	RMG 1/16W 22R 1% 0603
R224	4723-220A+P	RMG 1/16W 22R 1% 0603
R225	4723-102A+P	RMG 1/16W 1K 1%
R229	4723-000J+P-R	RMG 1/16W 0R 5% 0603
R230, R231	4723-220A+P	RMG 1/16W 22R 1% 0603
R233, R234	4723-153A+P	RMG 1/16W 15K 1%
R236, R237	4723-472A+P	RMG 1/16W 4.7K 1%.
R245	4723-472A+P	RMG 1/16W 4.7K 1%.
R248	4723-472A+P	RMG 1/16W 4.7K 1%.
R249	4723-220A+P	RMG 1/16W 22R 1% 0603
R254, R255, R257, R258	4723-220A+P	RMG 1/16W 22R 1% 0603
R260	4723-102A+P	RMG 1/16W 1K 1%
R264, R265	4723-153A+P	RMG 1/16W 15K 1%
R268, R269, R270	4723-220A+P	RMG 1/16W 22R 1% 0603
R272	4723-220A+P	RMG 1/16W 22R 1% 0603
R274	4723-472A+P	RMG 1/16W 4.7K 1%.
R275	4723-102A+P	RMG 1/16W 1K 1%
R277	4723-102A+P	RMG 1/16W 1K 1%
R278	4723-472A+P	RMG 1/16W 4.7K 1%.
R280	4723-201A+P	RMG 1/16W 200R 1% 0603
R281	4723-152A+P-R	RMG 1/16W 1.5K 1% 0603
R282	4723-331A+P	RMG 1/16W 330R 1% 0603
R285	4723-152A+P-R	RMG 1/16W 1.5K 1% 0603
R291	4723-153A+P	RMG 1/16W 15K 1%
R292	4723-912A+P	RMG 1/16W 9.1K 1%

<u>Location</u>	<u>Part Number</u>	<u>Description</u>
R293	4723-220A+P	RMG 1/16W 22R 1% 0603
R298	4723-222A+P	RMG 1/16W 2.2K 1%
R300	4723-202A+P	RMG 1/16W 2K 1%
R302	4723-100A+P-R	RMG 1/16W 10R 1% 0603
R308, R309, R310	4723-220A+P	RMG 1/16W 22R 1% 0603
R311	4723-202A+P	RMG 1/16W 2K 1%
R312, R313, R314, R315	4723-272A+P	RMG 1/16W 2.7K 1%
R321	4723-100A+P-R	RMG 1/16W 10R 1% 0603
R327, R330, R331	4723-472A+P	RMG 1/16W 4.7K 1%.
R338, R339	4723-220A+P	RMG 1/16W 22R 1% 0603
R340, R341	4723-272A+P	RMG 1/16W 2.7K 1%
R348	4723-102A+P	RMG 1/16W 1K 1%
R355, R356	4723-221A+P	RMG 1/16W 220R 1%
R360	4723-153A+P	RMG 1/16W 15K 1%
R361	4723-101A+P	RMG 1/16W 100R 1% 0603
R366	4723-101A+P	RMG 1/16W 100R 1% 0603
R369, R370	4723-472A+P	RMG 1/16W 4.7K 1%.
R371, R372, R373, R374	4723-220A+P	RMG 1/16W 22R 1% 0603
R376	4723-102A+P	RMG 1/16W 1K 1%
R379, R380	4723-153A+P	RMG 1/16W 15K 1%
R381, R382	4723-752A+P	RMG 1/16W 7.5K 1%
R385, R386	4723-153A+P	RMG 1/16W 15K 1%
R387, R388	4723-752A+P	RMG 1/16W 7.5K 1%
R391, R392	4723-562A+P	RMG 1/16W 5.6K 1%
R393, R394	4723-242A+P	RMG 1/16W 2.4K 1% 0603
R396	4723-183A+P	RMG 1/16W 18K 1%
R397	4720-470A+P	RMG 1/10W 47R 1% 0603
R398	4723-183A+P	RMG 1/16W 18K 1%
R399	4723-470A+P	RMG 1/16W 47R 1% 0603
R403, R404	4720-470A+P	RMG 1/10W 47R 1% 0603
R405, R406	4723-101A+P	RMG 1/16W 100R 1% 0603
R420, R421, R422	4723-220A+P	RMG 1/16W 22R 1% 0603
R426	4723-222A+P	RMG 1/16W 2.2K 1%
R427	4723-472J+P-R	RMG 1/16W 4.7K 5% 0603
R428	4723-222A+P	RMG 1/16W 2.2K 1%
R429	4723-102A+P	RMG 1/16W 1K 1%
R430	4723-222A+P	RMG 1/16W 2.2K 1%
R446	4723-272A+P	RMG 1/16W 2.7K 1%
R447, R448	4723-202A+P	RMG 1/16W 2K 1%
R449, R450	4723-000J+P-R	RMG 1/16W 0R 5% 0603
R451	4723-103A+P-R	RMG 1/16W 10K 1% 0603
R459	4723-000J+P-R	RMG 1/16W 0R 5% 0603
R464	4723-222A+P	RMG 1/16W 2.2K 1%
R465	4723-102A+P	RMG 1/16W 1K 1%

<u>Location</u>	<u>Part Number</u>	<u>Description</u>
R477	4723-000A+P	RMG 1/16W 0R 1% 0603
R478	4723-101A+P	RMG 1/16W 100R 1% 0603
R481	4723-102A+P	RMG 1/16W 1K 1%
<i>IC</i>		
IC200	3132-2561+0	IC LM809M3-3.08/NOPB
IC201	3132-0380+0	IC NCP1117ST18T3G
IC202, IC203	3132-1481+0	IC REG NCP1117ST33T3G
IC204, IC211	3130-2020+2	IC NJM7805FA-#ZZZB
IC205	3132-6701+0-16	IC DSP SRC4382 TQFP-48
IC206	3132-6791+0-20	IC MCU TMP86FS49AUG
IC207	3132-6730+0	IC MEMORY 24C1024 SOIC8
IC209	3132-6740+0	IC REGULATOR TA48015F
IC212	3131-9330+0	IC QUAD 2INPUT EXCLUSIVE
U200	3132-6512+0	IC DAC 2CH 192K WM8741
U202	3131-7990+0	IC TA7291SG(5/M)22240239
U203	3131-6940+0	IC LM393MNOPB (SMD)
U204	3130-2520+2	IC NJM7812FA-#ZZZB
U205	3130-3800+0	IC NJM7912FA-#ZZZB
U207	3132-4321+0	IC 6V 3-TERMINAL REGULAT
U208	3130-2020+2	IC NJM7805FA-#ZZZB
U210	3132-6451+0	IC QUAD BUFFER
U211	3132-6512+0	IC DAC 2CH 192K WM8741
U212, U213	3131-7310+0	IC OPA2134UA/2K5 SOP8
<i>FUSE</i>		
FC200 \triangle	5120-0050+0	FUSE T1.6A/250V 5X20
FC201, FC202 \triangle	5120-0018+0	FUSE T1A 250V 5X20
FC203 \triangle	5120-0035+0	FU T100MA 250V
FC204 \triangle	5120-0018+0	FUSE T1A 250V 5X20
<i>HEATSINK</i>		
HS202, HS203, HS204	5400-9130+0	HEAT SINK FOR 7805 2438-
HS207	5400-1702+0	HEATSINK 23.5X17X50
<i>SCREW</i>		
Screw001	2954-3008+0000	SCREW B-TITE BIND M3X8
Screw002	2954-2606+0000	SCREWS BT 2.6X6
<i>MISCELLANEOUS</i>		
CON201	2101-3235+0	CONNECTOR FFC 18P P1.25
CON208	2101-3256+0	CONNECTOR FFC 6P P1.0

<u>Location</u>	<u>Part Number</u>	<u>Description</u>
D221	481X-147L+2	PHOTO RECEIVER TORX147L
D222	481T-X147+2	PHOTO TRANSMITTER
F200, F201, F202, F203, F204, F205, F206, F207, F208, F209	4131-9131+0	FUSE HOLDER 6.5MM PITCH
HS200	5400-9132+0	HEATSINK 7805 2438-17
IC206	3000-9812+0	BLANK LABEL (5X10)
IC206-A	312A-0580+01	SOFTWARE MCU V1.3.3 D
J201	2101-3233+0	WAFER SOCKET 11P P3.96
J202	2113-1749+0	SOCKET DB9 D SUB RA
J205	2113-2036+1	JACK PHONE 4P RED D315
J206 *AH	635N-0002+0	WJ ROLLER FORM D=0.6MM
J207 *C	635N-0002+0	WJ ROLLER FORM D=0.6MM
L201, L202	1808-0887+0	FERRITE BEAD 1.25X2 0805
L205, L206	1803-0055+0	INDUCTOR CHIP 10UH
L208, L209, L210, L212, L213, L214	1808-0887+0	FERRITE BEAD 1.25X2 0805
P221	7012-9720+1	WIRE-CONN 1P #22 UL1015
P222	7012-6965+0	CONN WIRE 1P GND UL1015
RCA200	2113-2021+2	JACK RCA 1P ORANGE
<u>PWR ASSY</u>		
C	SVC-C56516+PWR	PCB ASSY PWR
<u>PC BOARD</u>		
C	1725-982A+0001	PCB MAIN/VFD/USB/PWR/VOL D
<u>CAPACITOR</u>		
C230	157T-475M+5-S5T	CE 400V 4.7U 20% RL
C232	150T-222M+5-SK	CC 400V 2200P 20% RL
C233	157D-477M+K-SXTU	CE 16V 470U 20% RLT
C235	153H-102J+K-IQ	CM 100V 0.001U 5% RLT 5X
C236	150F-104J+P-AC	CC 50V 0.1U 5% 0603
C237	157T-475M+5-S5T	CE 400V 4.7U 20% RL
C366	157F-106M+K-IU	CE 50V 10U 20% RLT 5X11
C367	150F-104J+P-AC	CC 50V 0.1U 5% 0603
Y200	150T-222M+5-SK	CC 400V 2200P 20% RL
<u>DIODE</u>		
D203	4840-8530+2	RECTIFIER UF4006-T GI AT
D204, D205, D206, D207	4804-0070+2	DIODE IN4007-F AT
D208	4804-0010+2	DIODE W1N4001-A(WA) AT
D209, D229	4801-48W0+3	DIODE 1N4148W SOD-123

<u>Location</u>	<u>Part Number</u>	<u>Description</u>
WAFER/SOCKET		
AC200	2101-1432+0	WAFER 2P P7.92 JAPAN
COIL		
L203	1807-273J+PS	COIL 27MH 5% 8.3X9.7
L207	1806-4041+0000	CHOKE COIL 7.7MH 10%
RELAY		
RL200	4500-0762+0	RELAY 5VDC 10A SPDT
RL205	4500-0753+0	RELAY 5VDC 1A DPDT BP-5
TRANSISTOR		
Q206, Q208	4858-46B0+3	TR BC846B SOT23 PHILIPS
RESISTOR		
R256	4723-563A+P-R	RMG 1/16W 56K 1% 0603
R227	4723-202A+P	RMG 1/16W 2K 1%
R262, R266	4723-102A+P	RMG 1/16W 1K 1%
R267	4718-104J+2	RMF 1W 100K 5% AT
R425	4723-102A+P	RMG 1/16W 1K 1%
R466	4723-202A+P	RMG 1/16W 2K 1%
TRANSFORMER		
T200	1806-4052+0000	TRANSFORMER PWR 110-230V
FUSE		
FC205 	5120-1096+0	FUSE 0.8A 250V 8X7 UL
MISCELLANEOUS		
AC203	7013-0920+0	WIRE-POWER 2P P7.92 #18
D230	3132-2981+0	IC ADJUST SHUNT REG
JP221	7013-0600+0	WIRE-SHILED 4P P2.0 #24
U201	3132-7351+0	IC POWER NCP1014 PDIP7
U215	481C-817A+3	PHOTOCOUPLER LTV817A
USB ASSY		
F	SVC-C56516+USB	PCB ASSY USB
PC BOARD		
F	1725-982A+0001	PCB MAIN/VFD/USB/PWR/VOL D

<u>Location</u>	<u>Part Number</u>	<u>Description</u>
CAPACITOR		
C395	150F-103J+P-AC	CC 50V 0.01U 5% 0603
JACK/SOCKET		
JP107	2113-3205+0	SOCKET USB USB-A-S-01
MISCELLANEOUS		
JP108	7013-0601+0	WIRE-SHILED 4P P2.0 #24
L222	1808-0887+0	FERRITE BEAD 1.25X2 0805
VFD ASSY		
B	SVC-C56516+VFD	PCB ASSY VFD part of fascia
PC BOARD		
B	1725-982A+0001	PCB MAIN/VFD/USB/PWR/VOL D
CAPACITOR		
C141	150F-104J+P-AC	CC 50V 0.1U 5% 0603
C142	157E-106M+K-IUK	CE 25V 10U 20% RLT 5X11
C143	150F-104J+P-AC	CC 50V 0.1U 5% 0603
C144	157F-105M+K-GM	CE 50V 1U 20% RLT 4X7
C145	150F-104J+P-AC	CC 50V 0.1U 5% 0603
C146, C147	15CH-470J+P-AC	CTC 0/60 47PF 5% 0603
C150, C151, C152	150F-100J+P-AC	CC 50V 10P 5% 0603
C153	150F-104J+P-AC	CC 50V 0.1U 5% 0603
DIODE		
D143	4801-48W0+3	DIODE 1N4148W SOD-123
Z101	4837-5B61+2	DZ 1/2W 5.45-5.73 ROHM
WAFER/SOCKET		
JP110	2102-040R+J01	WAFER 4P P2.0 90DEG
TRANSISTOR		
Q142	485C-1140+3	TR DTC114YKA 2216470R2
RESISTOR		
R146	4723-332A+P-R	RMG 1/16W 3.3K 1% 0603
R143, R144, R145	4723-471A+P-R	RMG 1/16W 470R 1% 0603
R155	4723-473A+P-R	RMG 1/16W 47K 1% 0603
R147	4723-751A+P	RMG 1/16W 750R 1% 0603

<u>Location</u>	<u>Part Number</u>	<u>Description</u>
R148	4723-222A+P	RMG 1/16W 2.2K 1%
R149	4723-682A+P	RMG 1/16W 6.8K 1%
R150	4723-303A+P	RMG 1/16W 30K 1%
R151	4723-751A+P	RMG 1/16W 750R 1% 0603
R152	4723-222A+P	RMG 1/16W 2.2K 1%
R153	4723-682A+P	RMG 1/16W 6.8K 1%
R154	4723-303A+P	RMG 1/16W 30K 1%
R156, R157	4723-472A+P	RMG 1/16W 4.7K 1%.
R158, R159	4723-220A+P	RMG 1/16W 22R 1% 0603
R161, R162, R163	4723-330A+P	RMG 1/16W 33R 1% 0603
R165	4723-102A+P	RMG 1/16W 1K 1%
R166	4720-470A+P	RMG 1/10W 47R 1% 0603
R167	4723-330A+P	RMG 1/16W 33R 1% 0603
SWITCH		
S101, S102, S103, S104, S105, S106, S107, S108	5200-4905+0	Replaces 5200-4861+0-01 TACT
MISCELLANEOUS		
CON141B	7013-0530+0	WIRE-CONN 4P P2.0 #28
CON142	2101-3237+0	CONNECTOR FFC 18P P1.25
Cusion1	4154-4881+1	CUSHION 21X8X2
L141	1808-0887+0	FERRITE BEAD 1.25X2 0805
M1, M2	4135-8341+0	HOLDER-VFD TINNED STEEL
REM0101	4816-043T+3	IR SENSOR KSM-603TM2
REM101	4151-9671+1	SPONGE 12X10X3
VFD101	2460-2270+0	DISPLAY-VFD MODULE
	2460-2270+1	IMPROVED BRIGHTNESS VFD
<u>VOL ASSY</u>		
D	SVC-C56516+VOL	PCB ASSY VOL <i>part of fascia</i>
PC BOARD		
D	1725-982A+0001	PCB MAIN/VFD/USB/PWR/VOL D
CAPACITOR		
C148, C149	150F-103J+P-AC	CC 50V 0.01U 5% 0603
MISCELLANEOUS		
JP109	7013-0490+0	WIRE-CONN 4P P2.0 #28
T100	5200-4978+0	ENCODER PUSH ROTARY SPST

<u>Location</u>	<u>Part Number</u>	<u>Description</u>
<u>SERVO ASSY</u>		
G	SVC-C56516+SERVO	PCB ASSY SERVO
<u>PC BOARD</u>		
E	1725-970A+0001	PCB SERVO BOARD D/S FR-4
<u>CAPACITOR</u>		
C1, C10, C11, C12, C13, C14, C15, C16, C17, C18, C19, C2, C20, C21, C22, C23, C24, C25, C26, C27, C28, C29, C3	150F-104K+P-AC	CC 50V 0.1uF 10%
C30, C31	157D-226M+K-IU	CE 16V 22U 20% RLT 5x11
C32, C33, C34	157D-107M+K-LUTU	CE 16V 100U 20% RLT
C35	15CH-470J+P-AC	CTC 0/60 47PF 5% 0603
C36, C37, C38	150F-333J+P-AC	CC 50V 0.033UF 5% 0603
C39	157D-107M+K-LUTU	CE 16V 100U 20% RLT
C4	150F-104K+P-AC	CC 50V 0.1uF 10%
C40, C41, C42	150F-103J+P-AC	CC 50V 0.01U 5% 0603
C43, C44	150F-153J+P-AC	CC 50V 0.015U 5% 0603
C45	15CH-680J+P-AC	CTC 0/60 68PF 5% 0603
C46	150F-102J+P-AC	CC 50V 1000P 5% 0603 X7R
C48	150F-750J+P-AC	CC 50V 75P 5% 0603
C49	150F-560J+P-AC	CC 50V 56P 5% 0603
C5	150F-104K+P-AC	CC 50V 0.1uF 10%
C50, C51	150F-473K+P-AC	CC 50V 0.047uF 10% 0603
C52	150F-222K+P-AC	CC 50V 2200pF 10% 0603 0
C53, C54	15CH-150J+P-AC	CTC 0/60 15pF 5% 0603
C55, C56, C57	157D-107M+K-LUTU	CE 16V 100U 20% RLT
C58	157E-477M+K-S5TU	CE 25V 470U 20% RLT
C59	150F-151J+P-AC	CC 50V 150P 5% 0603
C6	150F-153J+P-AC	CC 50V 0.015U 5% 0603
C60	150F-103J+P-AC	CC 50V 0.01U 5% 0603
C61	157D-226M+K-IU	CE 16V 22U 20% RLT 5x11
C62, C63	150F-471J+P-AC	CC 50V 470P 5% 0603
C65	150F-104K+P-AC	CC 50V 0.1uF 10%
C66	157D-107M+K-LUTU	CE 16V 100U 20% RLT
C68	150F-104K+P-AC	CC 50V 0.1uF 10%
C69	150F-100J+P-AC	CC 50V 10P 5% 0603
C7	150F-682K+P-AC	CC 50V 6800P 10%
C70	150F-100J+P-AC	CC 50V 10P 5% 0603
C71	157D-476M+K-IU	CE 16V 47U 20% RLT 5X11
C73, C74, C75	150F-104K+P-AC	CC 50V 0.1uF 10%
C76, C77	150F-220K+P-AC	CC 50V 22pF 10%
C78, C8, C80	150F-104K+P-AC	CC 50V 0.1uF 10%
C83, C84	150F-102J+P-AC	CC 50V 1000P 5% 0603 X7R

<u>Location</u>	<u>Part Number</u>	<u>Description</u>
C85	150F-104K+P-AC	CC 50V 0.1uF 10%
C86	157D-107M+K-IUI	CE 16V 100UF 20% RLT
C89	157D-107M+K-LUTU	CE 16V 100U 20% RLT
C9, C90	150F-104K+P-AC	CC 50V 0.1uF 10%
C91	157D-107M+K-LUTU	CE 16V 100U 20% RLT
C93	157D-476M+K-IU	CE 16V 47U 20% RLT 5X11
C94	150F-104K+P-AC	CC 50V 0.1uF 10%
C95	157D-107M+K-LUTU	CE 16V 100U 20% RLT
C96	150F-104K+P-AC	CC 50V 0.1uF 10%
DIODE		
D2	4804-0070+2	DIODE IN4007-F AT
D3	4804-1480+2	DIODE 1N4148T AT
WAFER/SOCKET		
J1	2102-030S+003	3P ST.WAFER P=2.0
J2	2101-3149+0	CONNECTOR FFC 15P P1.25
J5	2102-080S+003	8P ST. WAFER P=2.0
J7	2102-050S+003	5P ST. WAFER P=2.0
JP8	2102-040S+003	WAFER 4P P2.0 STRAIGHT
SW1	2101-0661+0	SHUNT 2P P=2.54
SW1	2101-1495+0	WAFER 3PIN P=2.54 ST 6MM
JACK/SOCKET		
J4	2113-1837+0	NPLG-6P-134 25055150
CRYSTAL		
X1	2300-0110+0	CRYSTAL 16.9344 MHZ
X5	2300-3306+0	CRYSTAL QUARTZ 32.768KHZ
X6	2300-3317+0	CRYSTAL 9.0MHZ +/-30PPM
TRANSISTOR		
Q1	4858-56B0+3	TR BC856B SOT23 PHILIPS
Q2	4851-4570+5	TR PNP 2SB1457 TO-92 RL
Q3, Q4, Q6	4860-0700+K	TR 2SC1815-GR(T E2/F/T) R
Q7	4852-668Y+U	TR NPN 2SC2668 Y:100-200
RESISTOR		
R1	4723-100J+P-R	RMG 1/16W 10R 5% 0603
R12, R13, R14, R16, R17, R19, R20, R22, R27, R36, R39, R41, R42, R45, R47, R48, R49, R52, R57, R58, R59, R61, R66, R67, R69, R78, R79, R8, R80, R81, R82, R83, R84, R85, R86, R87, R88, R89, R90, R91, R92, R93, R94, R95	4723-103A+P-R	RMG 1/16W 10K 1% 0603

<u>Location</u>	<u>Part Number</u>	<u>Description</u>
R10, R37, R38	4723-104A+P-R	RMG 1/16W 100K 1% 0603
R15	4723-223A+P-R	RMG 1/16W 22K 1% 0603
R73	4723-471A+P-R	RMG 1/16W 470R 1% 0603
R100, R101, R102, R103, R46, R5, R96, R97, R98, R99	4723-473A+P-R	RMG 1/16W 47K 1% 0603
R18	4723-560J+P-R	RMG 1/16W 56R 5% 0603
JP1, JP15	4723-000J+P-R	RMG 1/16W 0R 5% 0603
JP2	4723-332A+P-R	RMG 1/16W 3.3K 1% 0603
JP3, JP4	4723-000J+P-R	RMG 1/16W 0R 5% 0603
JP5	4723-472A+P	RMG 1/16W 4.7K 1%.
JP6	4723-133A+P-R	RMG 1/16W 13K 1% 0603
R11	4723-472A+P	RMG 1/16W 4.7K 1%.
R2	4723-154A+P-R	RMG 1/16W 150K 1% 0603
R21	4723-101A+P	RMG 1/16W 100R 1% 0603
R24	4723-000J+P-R	RMG 1/16W 0R 5% 0603
R25, R26	4723-270A+P	RMG 1/16W 27R 1% 0603
R29	4723-221A+P	RMG 1/16W 220R 1%
R3	4723-153A+P	RMG 1/16W 15K 1%
R30, R31, R32	4723-105A+P	RMG 1/16W 1M 1% 0603
R33, R34	4723-153A+P	RMG 1/16W 15K 1%
R35	4723-331A+P	RMG 1/16W 330R 1% 0603
R4	4723-334J+P	RMG 1/16W 330K 5%
R40	4723-101A+P	RMG 1/16W 100R 1% 0603
R43, R44	4723-000J+P-R	RMG 1/16W 0R 5% 0603
R54	4723-000J+P-R	RMG 1/16W 0R 5% 0603
R55, R56	4723-101A+P	RMG 1/16W 100R 1% 0603
R6	4723-472A+P	RMG 1/16W 4.7K 1%.
R60	4723-220A+P	RMG 1/16W 22R 1% 0603
R62	4723-220A+P	RMG 1/16W 22R 1% 0603
R63	4723-472A+P	RMG 1/16W 4.7K 1%.
R64	4723-220A+P	RMG 1/16W 22R 1% 0603
R65	4723-391A+P	RMG 1/16W 390R 1%
R68	4723-152A+P-R	RMG 1/16W 1.5K 1% 0603
R7	4723-910A+P	RMG 1/16W 91R 1% 0603
R70	4723-102A+P	RMG 1/16W 1K 1%
R71	4723-103A+P-R	RMG 1/16W 10K 1% 0603
R72	4723-153A+P	RMG 1/16W 15K 1%
R75, R76, R77	4723-220A+P	RMG 1/16W 22R 1% 0603
R9	4723-562A+P	RMG 1/16W 5.6K 1%
IC		
IC1	3132-6711+0-20	IC DSP TC94A73MFG
IC10	3132-6761+0	IC MEMORY EPROM
IC3	3132-6740+0	IC REGULATOR TA48015F
IC5	3132-7331+0	IC MCU TMP92FD28A

<u>Location</u>	<u>Part Number</u>	<u>Description</u>
IC77	3132-2821+0	IC LM1117S-3.3
IC8	3132-6720+0	IC REGULATOR TA4805F SMD
U2	3132-3231+0	IC MOTOR DRV W/3.3V REG
MISCELLANEOUS		
IC5	3000-9812+0	BLANK LABEL (5X10)
IC5-A	312A-0520+01	SOFTWARE SERVO MCU V4.0 D
J3	2101-3102+0	CONNECTOR FFC 16PIN P1.0
L1	1803-0055+0	INDUCTOR CHIP 10UH

- NOTE:**
- The components identified by \triangle mark are critical for risk of fire and electrical shock. Replace only with part number specified.
 - <*AH > : USA, Canadian model only.
 - <*C > : European model only.
 - Capacitors : CP-Polystyrene, CM-Mylar, CE-Electrolytic, CC-Ceramic, CTC-NPO.
 - Resistors : RMF-Metal Film, RCF-Carbon Film, RWR-Wirewound Metal Oxide.

MECHANISM EXPLODED VIEW

DA11VZ

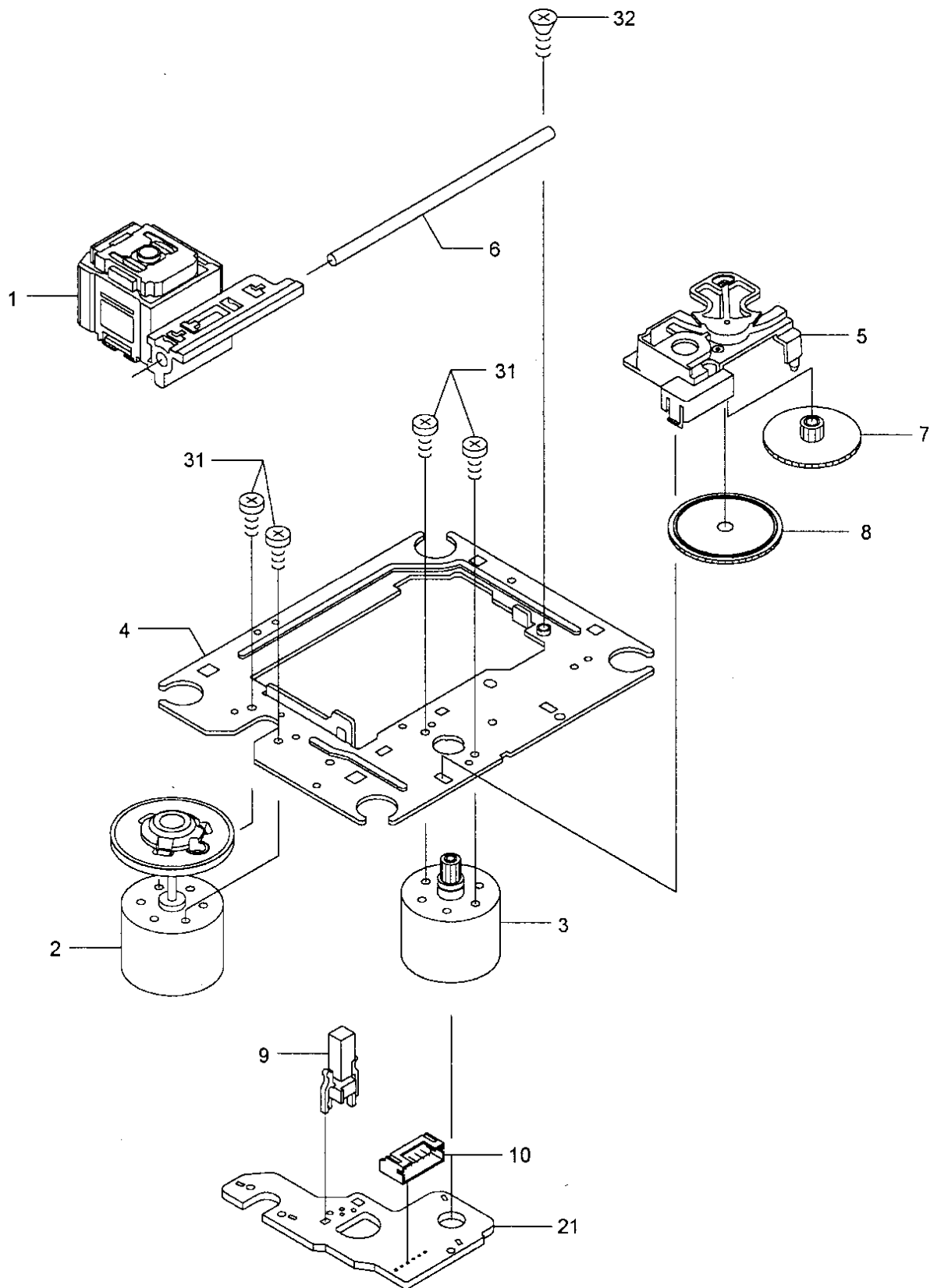

MECHANISM EXPLODED VIEW PARTS LIST

Item	Part No.	Description	Qty
1	NSP	ASSY, LASER, CDM DA11VZ	1
2	NSP	ASSY, MOTOR, SPINDLE	1
3	NSP	ASSY, MOTOR, SLED	1
4	NSP	CHASSIS	1
5	NSP	COVER, REAR	1
6	NSP	SAHFT, SLIDE	1
7	NSP	GEAR, MIDDLE	1
8	NSP	GEAR, DRIVE	1
9	NSP	SWITCH, LEAF	1
10	NSP	CONNECTOR-6P	1
21	NSP	MOTOR	1
31	NSP	SPECIAL SCREW M2.0uP.0	4
32	NSP	SPECIAL SCREW M2.6u6.0	1

EXPLODED VIEW

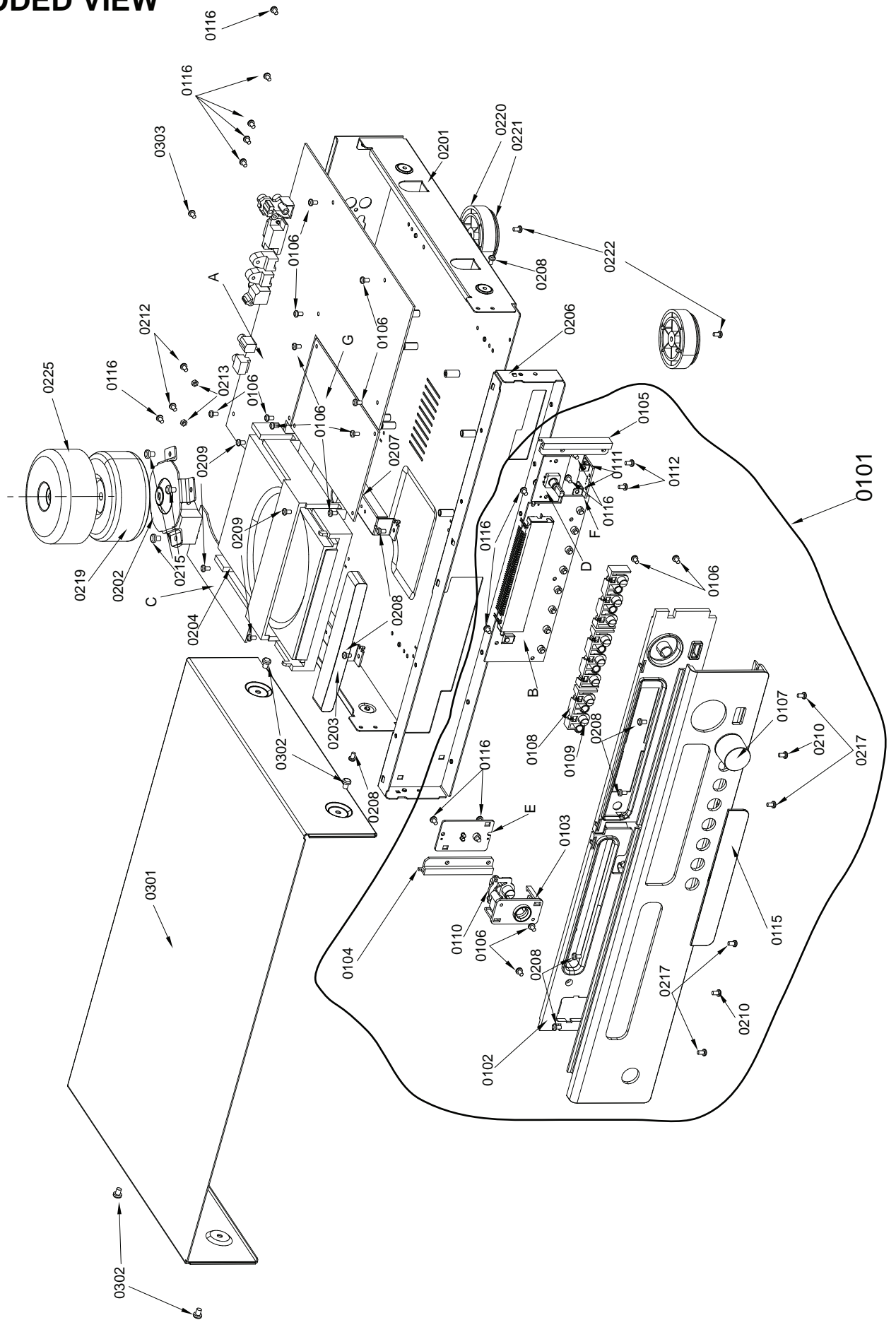

EXPLODED VIEW PARTS LIST

<u>Item</u>	<u>Part No.</u>	<u>Description</u>	<u>Q'ty</u>
0101 * Grey	SVC-C56517+FASC	PANEL-FRONT AL fascia assembly with cables	1
0101 * Titanium	SVC-C56516+FASC	PANEL-FRONT AL fascia assembly with cables	1
0102 * Grey	1468-5302+1	FRAME-FRONT NSP	1
0102 * Titanium	1468-5301+1	FRAME-FRONT NSP	1
0103 * Grey	3717-7013+0	FRONT LENS NSP	1
0103 * Titanium	3717-7011+0	FRONT LENS NSP	1
0104 * Grey	4135-8803+0	PLATE-LEFT NSP	1
0104 * Titanium	4135-8801+0	PLATE-LEFT NSP	1
0105 * Grey	4135-8804+0	PLATE-RIGHT NSP	1
0105 * Titanium	4135-8802+0	PLATE-RIGHT NSP	1
0106	2904-3006+0000	SCREW M3X6	19
0107 * Grey	2444-8402+0	KNOB-VOL/SELECT NSP	1
0107 * Titanium	2444-8401+0	KNOB-VOL/SELECT NSP	1
0108	2447-8801+0	BUTTON TRIO-INPUT NSP	3
0109 * Grey	2445-3801+0	BUTTON-SKIN NSP	8
0109 * Titanium	2445-3802+0	BUTTON-SKIN NSP	8
0110 * Grey	2444-8602+0	BOTTOM-POWER NSP	1
0110 * Titanium	2444-8601+0	BOTTOM-POWER NSP	1
0111	4135-7521+0	BRACKET-PHONE NSP	2
0115	3717-6811+0	LENS-DISPLAY NSP	1
0116	2954-3008+3000	SCREW 3X8 TAP	17
0201 * C	1402-352N+2	CHASSIS MAIN	1
0201 * AH	1402-352Q+2	CHASSIS MAIN	1
0202	4104-3721+0	TRANSFORMER BKT	1
0203 * Grey	1468-4001+0	CD DOOR	1
0203 * Titanium	1468-4002+0	CD DOOR	1
0204	SVC-C56516+MECH	DECK-CD CDM DA11VZ	1
0206	4135-8332+1	STRIP-TOP	1
0207	4135-8351+0	BRACKET-CD	2
0208	2904-3005+0000	SCREW M3X5	10
0209	2904-3010+0000	SCREW M3X10	4
0210 * Grey	2904-3005+3000	SCREW M3X5	2
0210 * Titanium	2904-3005+4000	SCREW M3X5	2
0212	2901-2605+3000	SCREW M2.6X5	2
0212	2904-3008+3000	SCREW M3X8	2
0213	2640-3022+0542	NUT HEX M3	2
0215	2900-4006+3010	M4X0.5PX6	4
0217 * Grey	2904-3005+3000	SCREW M3X5	4
0217 * Titanium	2904-3005+4000	SCREW M3X5	4
0219 △	1806-4047+0000	TRANSFORMER PWR	1
0220-0221	SVC-C56516+FOOT	FOOT-BOTTOM & CUSHION	4

Item	Part No.	Description	Q'ty
0222	2904-3005+3000	SCREW M3X5	4
0225	1454-2620+0	TRANSFORMER COVER	1
0301 * Grey	1402-3534+0	TOP COVER	1
0301 * Titanium	1402-3532+0	TOP COVER	1
0302 * Grey	2900-4006+3010	SCREW PW M4X6	4
0302 * Titanium	2900-4006+2010	SCREW PW M4X6	4
0303 * Grey	2954-3010+3000	SCREW 3X10 TAP	1
0303 * Titanium	2954-3010+4000	SCREW 3X10 TAP	1
A * AH	SVC-C56516+MAIN	PCB ASSY MAIN	1
A * C	SVC-C56526+MAIN	PCB ASSY MAIN	1
B	SVC-C56516+VFD	PCB ASSY VFD part of fascia 0101	1
C	SVC-C56516+PWR	PCB ASSY PWR	1
D	SVC-C56516+VOL	PCB ASSY VOL part of fascia 0101	1
E	SVC-C56516+LED	PCB ASSY LED part of fascia 0101	1
F	SVC-C56516+USB	PCB ASSY USB part of fascia 0101	1
G	SVC-C56516+SERVO	PCB ASSY SERVO	1

- NOTE:**
- The components identified by \triangle mark are critical for risk of fire and electrical shock. Replace only with part number specified.
 - <*AH > : USA, Canadian model only.
 - <*C > : European model only.

PACKING DIAGRAM

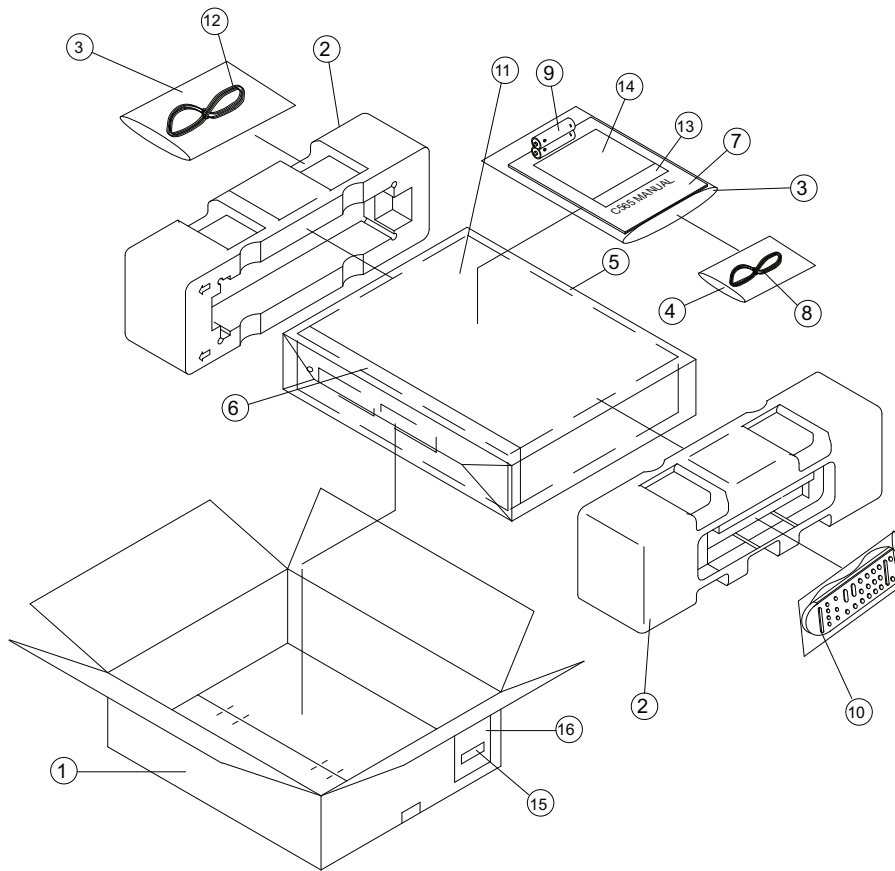

ITEM	PART NO.	DESCRIPTION	Q'TY
1.	1481-4601+0	GIFT BOX	1
2.	1490-4982+2	POLYFORM ENDCAP	2
3.	1497-1062+0	POLYBAG MANUAL	2
4.	1497-1302+0	POLYBAG	1
5.	1497-1332+1	POLYBAG	1
6.	4201-0010+0	NON WOVEN CLOTH BAG	1
7.	4301-7344+0	INSTRUCTION MANUAL CDR 4115-0017+0	1
8.	2103-7302+1	RCA PLUG CABLE	1
9.	4060-0930+0	GREENCELL AA SIZE GP15G	2
10.	8912-0110+0	REMOTE CONTROL	1
11.	1450-2520+0	WHITE PAPER	1
12.	7012-9450+0	CORD-AC UL/CSA 125V 10A - For AH Version	1
12.	7012-9470+0	CORD-AC PWR CE 250V 10A - For C Version	1
13.	3030-1057+2	SAFETY INSTRUCTION SHEET (AH VERSION ONLY)	1
14.	3030-1225+1	WARRANTY CARD (AH VERSION ONLY)	1
15.	3001-2305+0	LABEL SERIAL NO.	3
16.	3001-2306+0	LABEL BARCODE AH TITANIUM	2
16.	3001-2307+0	LABEL BARCODE AH GREY	2
16.	3001-2308+0	LABEL BARCODE C TITANIUM	2
16.	3001-2309+0	LABEL BARCODE C GREY	2

Proprietary information for servicing purposes only. The information herein may not be used commercially without the prior written agreement of NAD Electronics International, Toronto, Canada.