

SERVICE MANUAL

NAD

**STEREO
RECEIVER**

C720BEE

**STEREO
RECEIVER**

FACTORY DEFAULTS AND REGION SETTING PROCEDURES

RESET FOR AH VERSION	FM + DISC
RESET FOR C VERSION	FM + CD
TEST PRESETS 3FM & 3AM	AM + MEMORY
VFD ALL DISPLAY	AM + TAPE
AM FREQ. STEP	AM and then AM + FM MUTE
VERSION CHECK	FM + AM

C720BEE INPUT & PREAMPLIFIER

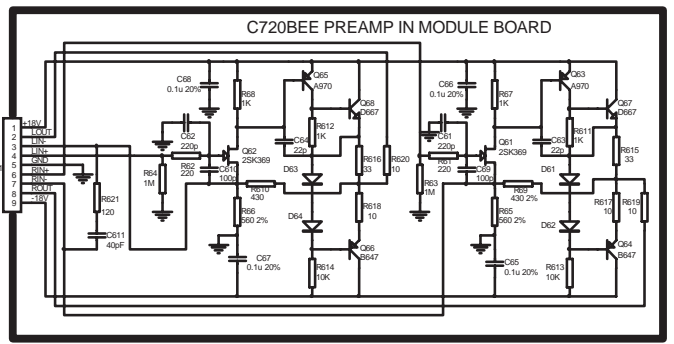
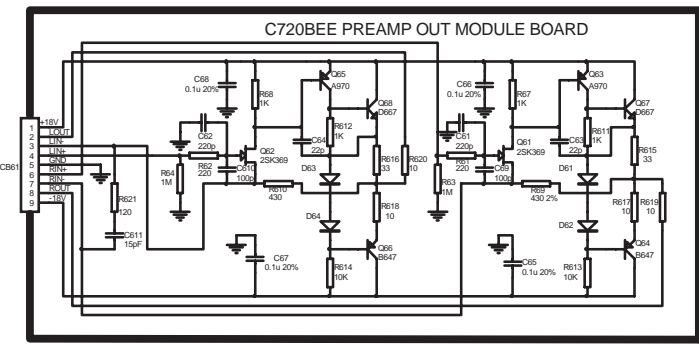
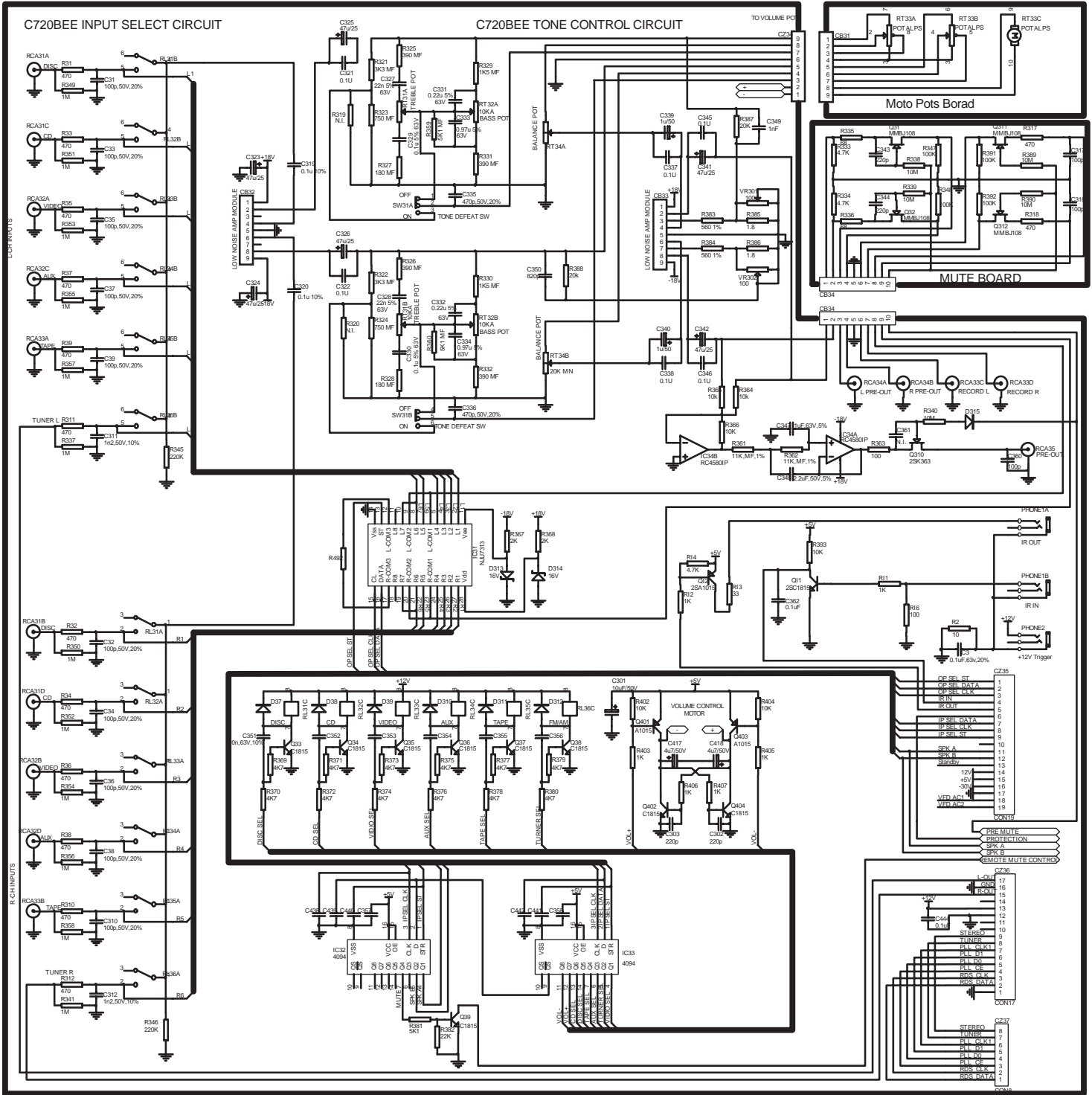

C720BEE KEYBOARD

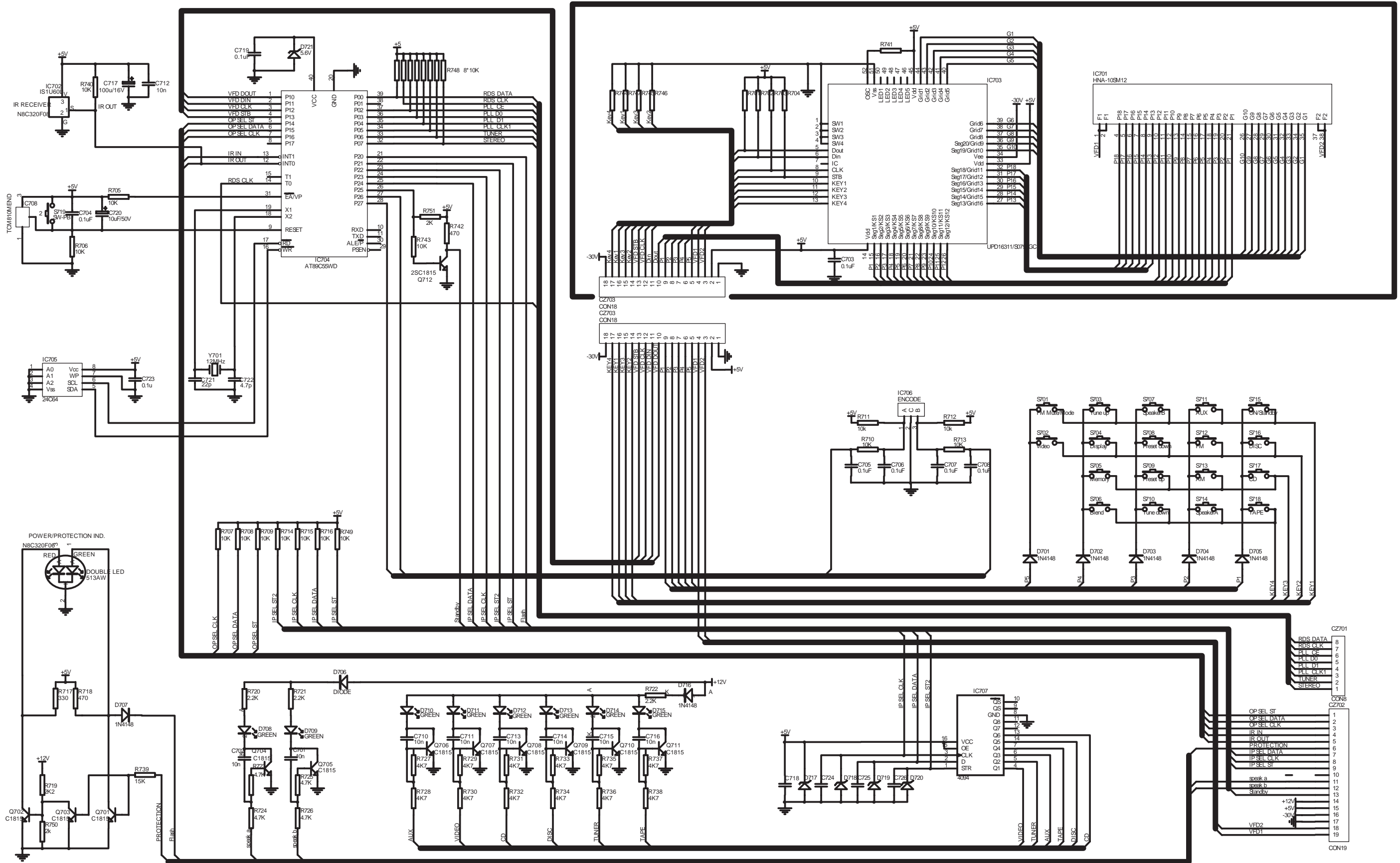

C720BEE POWER AMPLIFIER SECTION

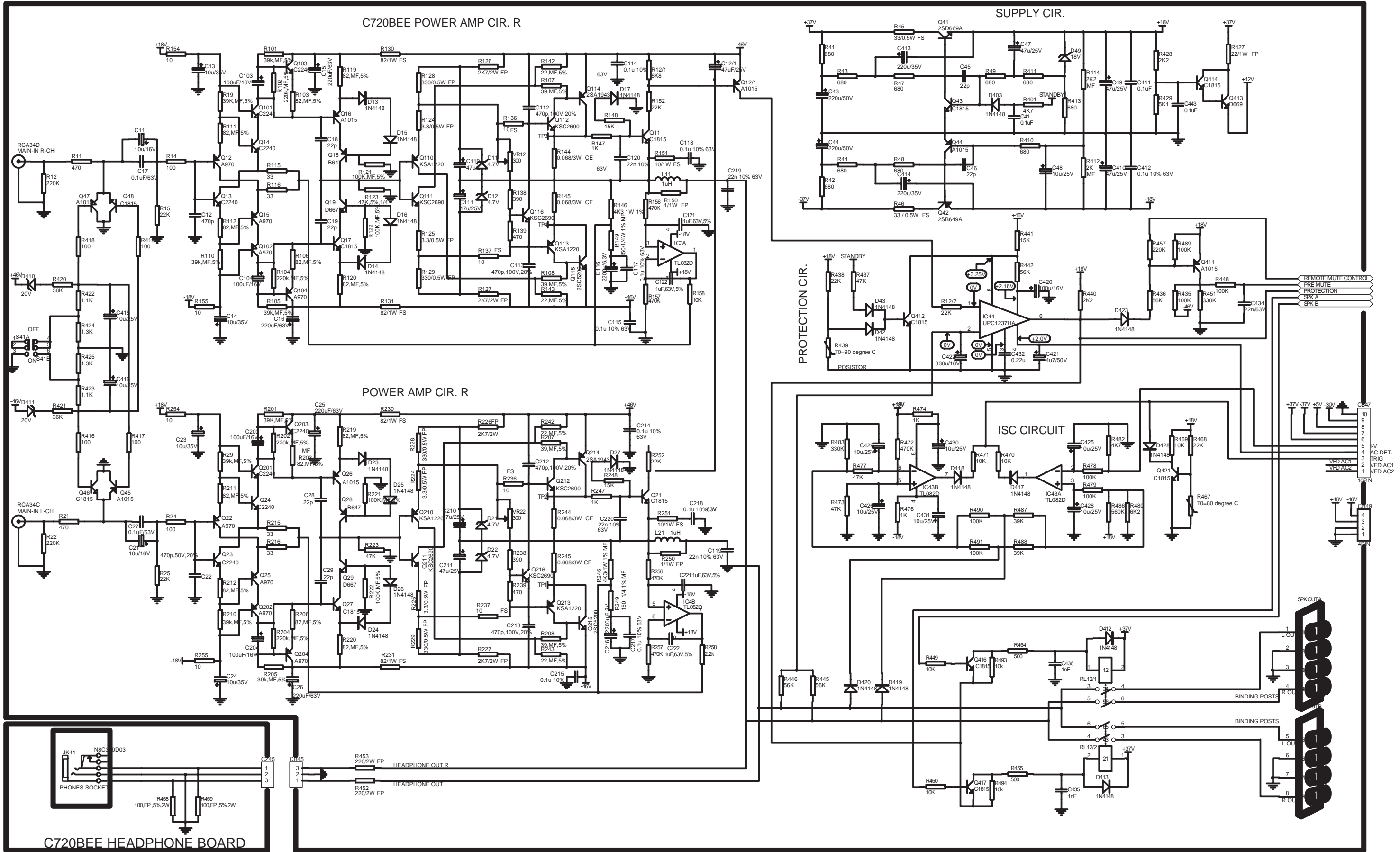

C720BEE PARTS LIST

Version: VM3.3

P/N	Description	part Type	Designator	Footprint	Qty	Manufacturer model no.
31-01220-00	Transistor	KSA1220	Q110, Q113, Q210, Q213, Q42	TO-126	5	KSA1220A-Y
31-02690-00	Transistor	KSC2690	Q111, Q112, Q211, Q212, Q116, Q216, Q41, Q413	TO-126	8	KSC2690A-Y
07-20220-10	METAL FILM	22Ω ±5% 1/4w	R142, R143, R242, R243	Pitch=10mm	4	RJ14-1/4W-22Ω ±5%
07-20390-10	METAL FILM	39Ω ±5% 1/4w	R107, R108, R207, R208	Pitch=10mm	4	RJ14-1/4W-39Ω ±5%
07-50100-10	FUSIBLE	10Ω/1/4W 5%	R136, R137, R236, R237	Pitch=10mm	4	RF10-1/4W-10Ω ±5%
07-50100-01	FUSIBLE	10Ω/1W 5%	R151, R251	Pitch=15mm	2	RF10-1W-10Ω ±5%
07-50330-00	FUSIBLE	33Ω/0.5W 5%	R45, R46	Pitch=10mm	2	RF10-1/2W-33Ω ±5%
07-50820-02	FUSIBLE	82Ω/1W 5%	R130, R131, R230, R231	Pitch=15mm	4	RF10-1W-82Ω ±5%
31-00170-00	JFET	2SK170-BL	Q61, Q62	TO-92	2x2	2SK170-BL
31-00108-01	JFET	PMBFJ108	Q31, Q32, Q311, Q312	SOT-23	4	
33-11500-01	ZENER DIODE	15V 0.5W	D52	Pitch=7.5mm	1	DZ15
33-30142-00	Rectifier Bridge	DB104	D501, D54, D56		3	DB104
33-60116-00	THYRITOR	TIC116D/BT151-500R	D531, D532	TO-220	2	TIC116D/BT151-500R
33-13000-02	ZENER DIODE	30V 0.5W	D53	PITCH=10mm	1	
03-01117-01	Regulator	AMS1117-5.0/LM1117MPX-5.0	IC51	SOT-223	1	AMS1117-5.0/LM1117MPX-5.0
20-12632-00	Fuse	T6.3AL250V-50T-063-H	F51, F52, F53, F54		4	618
20-12501-00	Fuse	500mA/250V	F55		1	618
20-20000-00	Fuse Holder	HF-004			10	HF-004
33-44148-03	SW DIODE	1N4148	D701, D702, D703, D704, D705, D706, D707, D716	Pitch=10mm	8	IN4148
33-50525-00	DUAL COLOR	515AW COM-Cathode	LED701		1	L-519EGF-W
03-08955-12	MICROCOPUTER	AT89C55WD-24PC/24PI	IC704	DIP40		
03-16311-01	VFD DRIVER	Upd16311GC-AB6	IC703	52-pin plastic QFP	1	Upd16311GC-AB6
或03-00791-01	VFD DRIVER	S0791GC	IC703	52-pin plastic QFP	1	S0791GC
36-01012-00	VFD	HNA-10SM12	IC701	single In-line Package	1	HNA-10SM12
13-12518-00	Housing	2.54,2x9PIN LONG 13.7mm	CZ703		1	
16-72003-13	VFD Board	47X128mm,1OUNCE FR-4 DOUBLE SIDE BOARD VM5.0			1	FR-4
14-72017-10	Connector	FPC线排 (180mm) 17PIN	CZ36——TUNER	S=1.25mm	1	1.25-17P-220MM
14-72019-00	Connector	FPC线排 (710mm) 19PIN	CZ35——CZ702	S=1.25mm	1	1.25-19P-710MM
75-009002-0	Sleeve	18mm			2	HS4-T562-B009V1-P004